



INTERNATIONAL APPLICATION PUBLISHED UNDER THE PATENT COOPERATION TREATY (PCT)

(51) International Patent Classification⁶ :

B05B 7/06, G01N 21/01

A1

(11) International Publication Number:

WO 99/30832

(43) International Publication Date:

24 June 1999 (24.06.99)

(21) International Application Number: PCT/IB98/02053

(22) International Filing Date: 16 December 1998 (16.12.98)

(30) Priority Data:

P 9702654	17 December 1997 (17.12.97)	ES
09/192,091	13 November 1998 (13.11.98)	US

(71) Applicant (for all designated States except US): UNIVERSIDAD DE SEVILLA [ES/ES]; Vicerrectorado de Investigacion, Valparaiso, 5-2ª planta, E-41013 Sevilla (ES).

(72) Inventor; and

(75) Inventor/Applicant (for US only): GANAN CALVO, Alfonso [ES/ES]; Camilo Jose Cela, nº4, Bloque 8, 3ªA, E-41018 Sevilla (ES).

(74) Agent: UNGRIA LOPEZ, Javier; Avenida Ramon y Cajal, 78, E-28043 Madrid (ES).

(81) Designated States: AL, AM, AT, AU, AZ, BA, BB, BG, BR, BY, CA, CH, CN, CU, CZ, DE, DK, EE, ES, FI, GB, GD, GE, GH, GM, HR, HU, ID, IL, IN, IS, JP, KE, KG, KP, KR, KZ, LC, LK, LR, LS, LT, LU, LV, MD, MG, MK, MN, MW, MX, NO, NZ, PL, PT, RO, RU, SD, SE, SG, SI, SK, SL, TJ, TM, TR, TT, UA, UG, US, UZ, VN, YU, ZW, ARIPO patent (GH, GM, KE, LS, MW, SD, SZ, UG, ZW), Eurasian patent (AM, AZ, BY, KG, KZ, MD, RU, TJ, TM), European patent (AT, BE, CH, CY, DE, DK, ES, FI, FR, GB, GR, IE, IT, LU, MC, NL, PT, SE), OAPI patent (BF, BJ, CF, CG, CI, CM, GA, GN, GW, ML, MR, NE, SN, TD, TG).

Published

With international search report.

(54) Title: STABILIZED CAPILLARY MICROJET AND DEVICES AND METHODS FOR PRODUCING SAME

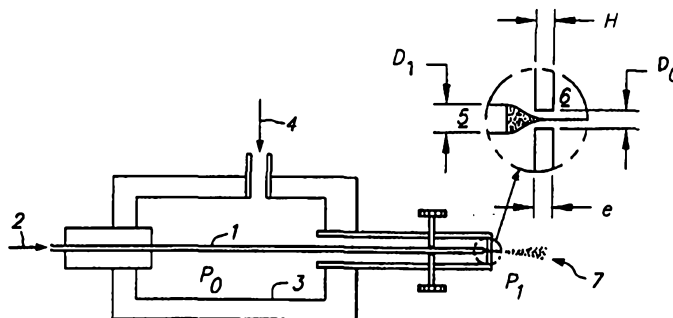

$$d_j \cong \left(\frac{8\rho_l}{\pi^2 \Delta P_g} \right)^{1/4} Q^{1/2} \quad (I)$$

(57) Abstract

The invention is directed to a stable capillary microjet and a monodisperse aerosol formed when the microjet dissociates. A variety of devices and methods are disclosed which allow for the formation of a stream of a first fluid (e.g. a liquid) characterized by forming a stable capillary microjet over a portion of the stream wherein the microjet portion of the stream is formed by a second fluid (e.g. a gas). The second fluid is preferably in a different state from the first fluid—liquid—gas or gas—liquid combinations. However, the first and second fluids may be two different fluids in miscible in each other. The stable capillary microjet comprises a diameter d_j at a given point A in the stream characterized by formula (I): wherein d_j is the diameter of the stable microjet, \cong indicates approximately equally to where an acceptable margin of error is $\pm 10\%$, ρ_l is the density of the liquid and ΔP_g is change in second fluid pressure from the second fluid pressure at a low velocity region (feeding region) upstream of point A to the second fluid pressure at point A.

FOR THE PURPOSES OF INFORMATION ONLY

Codes used to identify States party to the PCT on the front pages of pamphlets publishing international applications under the PCT.

AL	Albania	ES	Spain	LS	Lesotho	SI	Slovenia
AM	Armenia	FI	Finland	LT	Lithuania	SK	Slovakia
AT	Austria	FR	France	LU	Luxembourg	SN	Senegal
AU	Australia	GA	Gabon	LV	Latvia	SZ	Swaziland
AZ	Azerbaijan	GB	United Kingdom	MC	Monaco	TD	Chad
BA	Bosnia and Herzegovina	GE	Georgia	MD	Republic of Moldova	TG	Togo
BB	Barbados	GH	Ghana	MG	Madagascar	TJ	Tajikistan
BE	Belgium	GN	Guinea	MK	The former Yugoslav Republic of Macedonia	TM	Turkmenistan
BF	Burkina Faso	GR	Greece	ML	Mali	TR	Turkey
BG	Bulgaria	HU	Hungary	MN	Mongolia	TT	Trinidad and Tobago
BJ	Benin	IE	Ireland	MR	Mauritania	UA	Ukraine
BR	Brazil	IL	Israel	MW	Malawi	UG	Uganda
BY	Belarus	IS	Iceland	MX	Mexico	US	United States of America
CA	Canada	IT	Italy	NE	Niger	UZ	Uzbekistan
CF	Central African Republic	JP	Japan	NL	Netherlands	VN	Viet Nam
CG	Congo	KE	Kenya	NO	Norway	YU	Yugoslavia
CH	Switzerland	KG	Kyrgyzstan	NZ	New Zealand	ZW	Zimbabwe
CI	Côte d'Ivoire	KP	Democratic People's Republic of Korea	PL	Poland		
CM	Cameroon	KR	Republic of Korea	PT	Portugal		
CN	China	KZ	Kazakstan	RO	Romania		
CU	Cuba	LC	Saint Lucia	RU	Russian Federation		
CZ	Czech Republic	LI	Liechtenstein	SD	Sudan		
DE	Germany	LK	Sri Lanka	SE	Sweden		
DK	Denmark	LR	Liberia	SG	Singapore		
EE	Estonia						

and (c) making small inert particles which are used as standards in tests or as a substrate onto which compounds to be tested, reacted or assayed are coated.

Although there is a need for creating finely directed streams of fluids and for creating small spherical particles which are substantially uniform in size current methods suffer from a number of disadvantages. The invention described and disclosed herein is based on new discoveries in the field of physics which make it possible to overcome disadvantages of prior art devices and methods in an energy efficient manner.

SUMMARY OF THE INVENTION

The invention is directed to a stable capillary microjet and a monodisperse aerosol formed when the microjet dissociates. A variety of devices and methods are disclosed which allow for the formation of a stream of a first fluid (e.g. a liquid) characterized by forming a stable capillary microjet over a portion of the stream wherein the microjet portion of the stream is formed by a second fluid (e.g. a gas). The second fluid is preferably in a different state from the first fluid - - liquid-gas or gas-liquid combinations. However, the first and second fluids may be two different fluids immiscible in each other. The stable capillary microjet comprises a diameter d_j at a given point A in the stream characterized by the formula:

$$d_j \cong \left(\frac{8\rho_l}{\pi^2 \Delta P_g} \right)^{1/4} Q^{1/2}$$

wherein d_j is the diameter of the stable microjet, \cong indicates approximately equally to where an acceptable margin of error is $\pm 10\%$, ρ_l is the density of the liquid and ΔP_g is change in second fluid pressure from the second fluid pressure at a low velocity region (feeding region) upstream of point A to the second fluid pressure at the point A.

The microjet can have a diameter in the range of from about 0.1 micron to about 1 mm and a length in the range of from 1 micron to 50 mm. The stable jet is maintained, at least in part, by tangential viscous stresses exerted by the gas on the surface of the jet in an axial direction of the jet. The jet is further characterized by a slightly parabolic axial velocity profile and still further characterized by a Weber number (We) which is greater than 1 with the Weber number being defined by the formula:

$$We = \frac{\rho_g V_g^2 d}{\gamma}$$

wherein the ρ_g is the density of the gas, d is the diameter of the stable microjet, γ is the liquid-gas surface tension, and V_g^2 is the velocity of the gas squared.

Although the Weber number is greater than 1 when a stable microjet is obtained the Weber number should be less than 40 to obtain a desired monodisperse aerosol. Thus, 5 desired results are obtained within the parameters of $1 \leq We \leq 40$. Monodisperse aerosols of the invention have a high degree of uniformity in particle size. The particles are characterized by having the same diameter with a deviation in diameter from one particle to another in a range of about $\pm 3\%$ to about $\pm 30\%$, preferably about $\pm 3\%$ to about $\pm 10\%$ and most preferably $\pm 3\%$ or less. The particles in an aerosol will have 10 consistency in size but may be produced to have a size in a range of about 0.1 micron to about 100 microns.

An object of the invention is to provide a stream of a first fluid (e.g. a liquid) which stream is characterized by forming a stable capillary microjet over a portion of the stream wherein this stable capillary microjet portion of the stream is formed by a second 15 fluid (e.g. a gas) moving at a velocity greater than that of the first fluid.

Another object of the invention is to provide a monodisperse aerosol of liquid particles in air wherein the particles are characterized by having the same diameter with a deviation in diameter from one particle to another in a range of from about $\pm 3\%$ to about $\pm 30\%$ wherein the particles are produced as a result of a break up of the stable capillary 20 microjet.

An advantage of the invention is that the microjet of liquid flows through an opening surrounded by a focusing funnel of gas so that liquid does not touch the peripheral area of the opening and therefor does not deposit on the opening and cause clogging.

Another advantage of the invention is that the particles formed are highly 25 uniform in size and are created with a relatively small amount of energy.

A feature of the invention is that various parameters including the viscosities and velocities of the fluids can be chosen with consideration to other adjusted parameters to obtain a capillary supercritical flow of liquid in the form of a stable capillary microjet.

Another advantage of the invention is that the positions of the liquid and gas within the various embodiments of the invention can be changed in order to obtain a variety of different effects. For example, when aqueous liquid forms a stable capillary microjet surrounded by a focusing funnel of gas which escapes into a surrounding gas at lower pressure, aerosolized particles are formed. In another example a flow stream of gas focused by a surrounding focusing funnel of liquid which flows outward into a liquid forms gas bubbles which are highly uniform and extremely small in size.

An advantage of the invention is that the embodiments can be used to form small gas bubbles which are uniform in size and sufficiently small to provide for a high degree of diffusion of the gas present in the bubble into the surrounding liquid, thereby providing advantages such as oxygenating water or decontaminating gas.

These and other aspects, objects, features and advantages will become apparent to those skilled in the art upon reading this disclosure in combination with the figures provided.

15

BRIEF DESCRIPTION OF THE DRAWINGS

Figure 1 is a schematic view showing the basic components of one embodiment of the invention with a cylindrical feeding needle as a source of formulation.

Figure 2 is a schematic view of another embodiment of the invention with two concentric tubes as a source of formulation.

Figure 3 is a schematic view of yet another embodiment showing a wedge-shaped planar source of formulation. Figure 3a illustrates a cross-sectional side view of the planar feeding source and the interaction of the fluids. Figure 3b show a frontal view of the openings in the pressure chamber, with the multiple openings through which the atomizate exits the device. Figure 3c illustrates the channels that are optionally formed within the planar feeding member. The channels are aligned with the openings in the pressure chamber.

Figure 4 is a schematic view of a stable capillary microjet being formed and flowing through an exit opening to thereafter form a monodisperse aerosol.

Figure 5 is a graph of data where 350 measured values of d_p/d_o versus Q/Q_o are plotted.

30

Figure 6 is a schematic view of the critical area of a device of the type shown in Figure 1 showing gas surrounded by liquid expelled into a liquid to form bubbles.

Figure 7 is a schematic view as in Figure 6 but with the bubbles flowing into a gas.

5 Figure 8 is a schematic view as in Figure 6 but with two immiscible liquids flowing into a gas.

DETAILED DESCRIPTION OF PREFERRED EMBODIMENTS

10 Before the present aerosol device and method are described, it is to be understood that this invention is not limited to the particular components and steps described, as such may, of course, vary. It is also to be understood that the terminology used herein is for the purpose of describing particular embodiments only, and is not intended to be limiting, since the scope of the present invention will be limited only by the appended claims.

15 It must be noted that as used herein and in the appended claims, the singular forms "a", "and," and "the" include plural referents unless the context clearly dictates otherwise. Thus, for example, reference to "a particle" includes a plurality of particles and reference to "a fluid" includes reference to a mixture of fluids, and equivalents thereof known to those skilled in the art, and so forth.

20 Unless defined otherwise, all technical and scientific terms used herein have the same meaning as commonly understood by one of ordinary skill in the art to which this invention belongs. Although any methods and materials similar or equivalent to those described herein can be used in the practice or testing of the present invention, the preferred methods and materials are now described. All publications mentioned herein are
25 incorporated herein by reference to disclose and describe the methods and/or materials in connection with which the publications are cited.

The publications discussed herein are provided solely for their disclosure prior to the filing date of the present application. Nothing herein is to be construed as an admission
30 invention. Further, the dates of publication provided may be different from the actual publication dates which may need to be independently confirmed.

DEVICE IN GENERAL

Different embodiments are shown and described herein (see Figures 1, 2 and 3) which could be used in producing the stable capillary microjet and/or a dispersion of particles which are substantially uniform in size. Although various embodiments are part of the invention, they are merely provided as exemplary devices which can be used to convey the essence of the invention, which is the formation of a stable capillary microjet and/or uniform dispersion of particles.

A basic device comprises (1) a means for supplying a first fluid and (2) a pressure chamber supplied with a second fluid which flows out of an exit opening in the pressure chamber. The exit opening of the pressure chamber is aligned with the flow path of the means for supplying the first fluid. The embodiments of Figures 1, 2 and 3 clearly show that there can be a variety of different means for supplying the first fluid. Other means for supplying a first fluid flow stream will occur to those skilled in the art upon reading this disclosure.

Further, other configurations for forming the pressure chamber around the means for supplying the first fluid will occur to those skilled in the art upon reading this disclosure. Such other embodiments are intended to be encompassed by the present invention provided the basic conceptual results disclosed here are obtained, i.e. a stable capillary microjet is formed and/or a dispersion of particle highly uniform in size is formed. To simplify the description of the invention, the means for supplying a first fluid is often referred to as a cylindrical tube (see Figure 1) and the first fluid is generally referred to as a liquid. The liquid can be any liquid depending on the overall device which the invention is used within. For example, the liquid could be a liquid formulation of a pharmaceutically active drug used to create an aerosol for inhalation or, alternatively, it could be a hydrocarbon fuel used in connection with a fuel injector for use on an internal combustion engine or heater or other device which burns hydrocarbon fuel. Further, for purposes of simplicity, the second fluid is generally described herein as being a gas and that gas is often preferably air. However, the first fluid may be a gas and second fluid a liquid or both fluids may be liquid provided the first and second fluid are sufficiently different from each other (immiscible) so as to allow for the formation of a stable microjet of the first fluid moving from the supply means to an exit port of the pressure chamber. Notwithstanding these different combinations of gas-liquid, liquid-gas, and liquid-liquid, the invention is generally described with a liquid

formulation being expelled from the supply means and forming a stable microjet due to interaction with surrounding air flow focusing the microjet to flow out of an exit of the pressure chamber.

Formation of the microjet and its acceleration and ultimate particle formation are based on the abrupt pressure drop associated with the steep acceleration experienced by the liquid on passing through an exit orifice of the pressure chamber which holds the second fluid (i.e. the gas). On leaving the chamber the flow undergoes a certain pressure difference between the liquid and the gas, which in turn produces a highly curved zone on the liquid surface near the exit port of the pressure chamber and in the formation of a cuspidal point from which a steady microjet flows, provided the amount of the liquid withdrawn through the exit port of the pressure chamber is replenished. Thus, in the same way that a glass lens or a lens of the eye focuses light to a given point, the flow of the gas surrounds and focuses the liquid into a stable microjet. The focusing effect of the surrounding flow of gas creates a stream of liquid which is substantially smaller in diameter than the diameter of the exit orifice of the pressure chamber. This allows liquid to flow out of the pressure chamber orifice without touching the orifice, providing advantages including (1) clogging of the exit orifice is virtually eliminated, (2) contamination of flow due to contact with substances (e.g. bacteria or particulate residue) on the orifice opening is virtually eliminated, and (3) the diameter of the stream and the resulting particles are smaller than the diameter of the exit orifice of the chamber. This is particularly desirable because it is difficult to precisely engineer holes which are very small in diameter. Further, in the absence of the focusing effect (and formation a stable microjet) flow of liquid out of an opening will result in particles which have about twice the diameter of the exit opening. An additional advantage is that the particles are not prone to agglomeration following exit from the chamber owing to the accelerating effect of the surrounding gas stream, which has a velocity larger than the liquid velocity.

The description provided here generally indicates that the fluid leaves the pressure chamber through an exit orifice surrounded by the gas and thereafter enters into a gaseous surrounding environment which may be air held at normal atmospheric pressure, or, alternatively, the gas (heated pressurized air) inside an internal combustion engine. However, when the first fluid is a gas and the second fluid is a liquid the fluid present outside of the chamber may also be a liquid. This configuration is particularly useful when

it is necessary to create very small highly uniform bubbles which are moved into a liquid surrounding exit opening of the pressure chamber. The need for the formation of very small highly uniform bubbles into a gas occurs in a variety of different industrial applications. For example, water needs to be oxygenated in a variety of situations including small at home
5 fish tanks and large volume fisheries. The additional oxygen can aid the rate of growth of the fish and thereby improve production for the fishery. In another embodiment, oxygen or air bubbles can be forced into liquid sewage in order to aid in treatment. In yet another application of the invention, contaminated gases such as a gas contaminated with a radioactive material can be formed into small uniformed bubbles and blown into a liquid
10 where the contamination in the gas will diffuse into the liquid, thereby cleaning the gas. The liquid will, of course, occupy substantially less volume and therefore be substantially easier to dispose of than contaminated toxic gas.

Those skilled in the art will recognize that variations on the different embodiments disclosed below will be useful in obtaining particularly preferred results. Specific
15 embodiments of devices are now described.

EMBODIMENT OF FIGURE 1

A first embodiment of the invention where the supply means is a cylindrical feeding needle supplying liquid into a pressurized chamber of gas is described below with reference to
20 Figure 1.

The components of the embodiment of Figure 1 are as follows:

1. Feeding needle - also referred to generally as a fluid source and a tube.
2. End of the feeding needle used to insert the liquid to be atomized.
3. Pressure chamber.
- 25 4. Orifice used as gas inlet.
5. End of the feeding needle used to evacuate the liquid to be atomized.
6. Orifice through which withdrawal takes place.
7. Atomizate (spray) - also referred to as aerosol.

D_1 = diameter of the feeding needle; D_o = diameter of the orifice
30 through which the microjet is passed; e = axial length of the orifice through which withdrawal takes place; H = distance

from the feeding needle to the microjet outlet; P_o = pressure inside the chamber; P_a = atmospheric pressure.

Although the device can be configured in a variety of designs, the different designs will all include the essential components shown in Figure 1 or components which perform an equivalent function and obtain the desired results. Specifically, a device of the invention will be comprised of at least one source of a first fluid (e.g., a feeding needle with an opening 2) into which a first fluid such as liquid flowable formulation can be fed and an exit opening 5 from which the formulation can be expelled. The feeding needle 1, or at least its exit opening 5, is encompassed by a pressure chamber 3. The chamber 3 has inlet opening 4 which is used to feed a second fluid (e.g. a gas) into the chamber 3 and an exit opening 6 through which gas from the pressure chamber and liquid formulation from the feeding needle 3 are expelled. When the first fluid is a liquid it is expelled into gas to create an aerosol. When the first fluid is a gas it is expelled into a liquid to create bubbles.

In Figure 1, the feeding needle and pressure chamber are configured to obtain a desired result of producing an aerosol wherein the particles are small and uniform in size or bubbles which are small and uniform in size. The particles or bubbles have a size which is in a range of 0.1 to 100 microns. The particles of any given aerosol or bubbles will all have about the same diameter with a relative standard deviation of $\pm 10\%$ to $\pm 30\%$ or more preferably $\pm 3\%$ to $\pm 10\%$. Stating that particles of the aerosol have a particle diameter in a range of 1 to 5 microns does not mean that different particles will have different diameters and that some will have a diameter of 1 micron while others of 5 microns. The particles in a given aerosol will all (preferably about 90% or more) have the same diameter $\pm 3\%$ to $\pm 30\%$. For example, the particles of a given aerosol will have a diameter of 2 microns $\pm 3\%$ to $\pm 10\%$. The same deviations are also correct for the formation of bubbles.

Such a monodisperse aerosol is created using the components and configuration as described above. However, other components and configurations will occur to those skilled in the art. The object of each design will be to supply fluid so that it creates a stable capillary microjet which is accelerated and stabilized by tangential viscous stress exerted by the second fluid on the first fluid surface. The stable microjet created by the second fluid leaves the pressurized area (e.g., leaves the pressure chamber and exits the pressure chamber orifice) and splits into particles or bubbles which have the desired size and uniformity.

The parameter window used (*i.e.* the set of special values for the liquid properties, flow-rate used, feeding needle diameter, orifice diameter, pressure ratio, *etc.*) should be large enough to be compatible with virtually any liquid (dynamic viscosities in the range from 10^{-4} to $1 \text{ kg m}^{-1}\text{s}^{-1}$); in this way, the capillary microjet that emerges from the end of the feeding
5 needle is absolutely stable and perturbations produced by breakage of the jet cannot travel upstream. Downstream, the microjet splits into evenly shaped drops simply by effect of capillary instability (see, for example, Rayleigh, "On the instability of jets", Proc. London Math. Soc., 4-13, 1878), similar in a manner to a laminar capillary jet falling from a half-open tap.

10 When the stationary, steady interface is created, the capillary jet that emerges from the end of the drop at the outlet of the feeding point is concentrically withdrawn into the nozzle. After the jet emerges from the drop, the liquid is accelerated by tangential sweeping forces exerted by the gas stream flowing on its surface, which gradually decreases the jet cross-section. Stated differently the gas flow acts as a lens and focuses and stabilizes the
15 microjet as it moves toward and into the exit orifice of the pressure chamber.

The forces exerted by the second fluid flow on the first fluid surface should be steady enough to prevent irregular surface oscillations. Therefore, any turbulence in the gas motion should be avoided; even if the gas velocity is high, the characteristic size of the orifice should ensure that the gas motion is laminar (similar to the boundary layers formed on the jet
20 and on the inner surface of the nozzle or hole).

STABLE CAPILLARY MICROJET

25 Figure 4 illustrates the interaction of a liquid and a gas to form atomizate using the method of the invention. The feeding needle 60 has a circular exit opening 61 with an internal radius R_1 which feeds a liquid 62 out of the end, forming a drop with a radius in the range of R_1 to R_1 plus the thickness of the wall of the needle. Thereafter, the drop narrows in circumference to a much smaller circumference as is shown in the expanded view of the tube
30 (*i.e.* feeding needle) 5 as shown in Figures 1 and 4. The exiting liquid flow comprises an infinite amount of liquid streamlines 63 that after interaction of the liquid with the surrounding gas to form a stable cusp at the interface 64 of the two fluids. The surrounding

gas also forms an infinite number of gas streamlines 65, which interact with the solid surfaces and the exiting liquid to create the effect of a virtual focusing funnel 66. The exiting liquid is focused by the focusing funnel 66 resulting in a stable capillary microjet 67, which remains stable until it exits the opening 68 of the pressure chamber 69. After exiting the pressure chamber, the microjet begins to break-up, forming monodispersed particles 70.

The gas flow, which affects the liquid withdrawal and its subsequent acceleration after the jet is formed, should be very rapid but also uniform in order to avoid perturbing the fragile capillary interface (the surface of the drop that emerges from the jet).

As illustrated in Figure 4, the exit opening 61 of the capillary tube 60 is positioned close to an exit opening 68 in a planar surface of a pressure chamber 69. The exit opening 68 has a minimum diameter D_0 and is in a planar member with a thickness e . The diameter D_0 is referred to as a minimum diameter because the opening may have a conical configuration with the narrower end of the cone positioned closer to the source of liquid flow. Thus, the exit opening may be a funnel-shaped nozzle although other opening configurations are also possible, e.g. an hour glass configuration. Gas in the pressure chamber continuously flows out of the exit opening. The flow of the gas causes the liquid drop expelled from the tube to decrease in circumference as the liquid moves away from the end of the tube in a direction toward the exit opening of the pressure chamber.

In actual use, it can be understood that the opening shape which provokes maximum gas acceleration (and consequently the most stable cusp and microjet with a given set of parameters) is a conically shaped opening in the pressure chamber. The conical opening is positioned with its narrower end toward the source of liquid flow.

The distance between the end 61 of the tube 60 and the beginning of the exit opening 68 is H . At this point it is noted that R_1 , D_0 , H and e are all preferably on the order of hundreds of microns. For example, $R_1 = 400\mu\text{m}$, $D_0 = 150\mu\text{m}$, $H = 1\text{mm}$, $e = 300\mu\text{m}$. However, each could be 1/100 to 10x these sizes.

The end of the liquid stream develops a cusp-like shape at a critical distance from the exit opening 68 in the pressure chamber 69 when the applied pressure drop ΔP_g through the exit opening 68 overcomes the liquid-gas surface tension stresses γ/R^* appearing at the point of maximum curvature — e.g. $1/R^*$ from the exit opening.

A steady state is then established if the liquid flow rate Q ejected from the drop cusp is steadily supplied from the capillary tube. This is the stable capillary cusp which is an

essential characteristic of the invention needed to form the stable microjet. More particularly, a steady, thin liquid jet with a typical diameter d_j is smoothly emitted from the stable cusp-like drop shape and this thin liquid jet extends over a distance in the range of microns to millimeters. The length of the stable microjet will vary from very short (e.g. 1 micron) to very long (e.g. 50 mm) with the length depending on the (1) flow-rate of the liquid and (2) the Reynolds number of the gas stream flowing out of the exit opening of the pressure chamber. The liquid jet is the stable capillary microjet obtained when supercritical flow is reached. This jet demonstrates a robust behavior provided that the pressure drop ΔP_g applied to the gas is sufficiently large compared to the maximum surface tension stress (on the order of γ/d_j) that act at the liquid-gas interface. The jet has a slightly parabolic axial velocity profile which is, in large part, responsible for the stability of the microjet. The stable microjet is formed without the need for other forces, i.e. without adding force such as electrical forces on a charged fluid. However, for some applications it is preferable to add charge to particles, e.g. to cause the particles to adhere to a given surface. The shaping of liquid exiting the capillary tube by the gas flow forming a focusing funnel creates a cusp-like meniscus resulting in the stable microjet. This is a fundamental characteristic of the invention.

The stable capillary microjet is maintained stably for a significant distance in the direction of flow away from the exit from the tube. The liquid is, at this point, undergoing "supercritical flow." The microjet eventually destabilizes due to the effect of surface tension forces. Destabilization results from small natural perturbations moving downstream, with the fastest growing perturbations being those which govern the break up of the microjet, eventually creating a uniform sized monodisperse aerosol 70 as shown in Figure 4.

The microjet, even as it initially destabilizes, passes out of the exit orifice of the pressure chamber without touching the peripheral surface of the exit opening. This provides an important advantage of the invention which is that the exit opening 68 (which could be referred to as a nozzle) will not clog from residue and/or deposits of the liquid. Clogging is a major problem with very small nozzles and is generally dealt with by cleaning or replacing the nozzle. When fluid contacts the surfaces of a nozzle opening some fluid will remain in contact with the nozzle when the flow of fluid is shut off. The liquid remaining on the nozzle surface evaporates leaving a residue. After many uses over time the residue builds up and clogging takes place. The present invention substantially reduces or eliminates this clogging problem.

MATHEMATICS OF A STABLE MICROJET

Cylindrical coordinates (r,z) are chosen for analyzing the shape of a stable microjet, i.e. a liquid jet undergoing "supercritical flow." The cusp-like meniscus formed by the liquid coming out of the tube is pulled toward the exit of the pressure chamber by a pressure gradient
5 created by the flow of gas.

The cusp-like meniscus formed at the tube's mouth is pulled towards the hole by the pressure gradient created by the gas stream. From the cusp of this meniscus, a steady liquid thread with the shape of radius $r = \xi$ is withdrawn through the hole by the action of both the suction effect due to ΔP_g , and the tangential viscous stresses τ_s , exerted by the gas on the jet's
10 surface in the axial direction. The averaged momentum equation for this configuration may be written

$$\frac{d}{dz} \left[P_1 + \frac{\rho_1 Q^2}{2\pi^2 \xi^4} \right] = -\frac{2\tau_s}{\xi}, \quad (1)$$

where Q is the liquid flow rate upon exiting the feeding tube, P_1 is the liquid pressure, and ρ_1 is
15 the liquid density, assuming that the viscous extensional term is negligible compared to the kinetic energy term, as will be subsequently justified. In addition, liquid evaporation effects are neglected. The liquid pressure P_1 is given by the capillary equation.

$$P_1 = P_g + \gamma/\xi. \quad (2)$$

where γ is the liquid-gas surface tension. As shown in the Examples, the pressure drop ΔP_g is sufficiently large as compared to the surface tension stress γ/ξ to justify neglecting the latter in
20 the analysis. This scenario holds for the whole range of flow rates in which the microjet is absolutely stable. In fact, it will be shown that, for a given pressure drop ΔP_g , the minimum liquid flow rate that can be sprayed in steady jet conditions is achieved when the surface tension stress γ/ξ is of the order of the kinetic energy of the liquid $\rho_1 Q^2/(2\pi^2 \xi^4)$, since the

surface tension acts like a "resistance" to the motion (it appears as a *negative* term in the right-hand side term of Eq. (1)). Thus,

$$Q_{min} \sim \left(\frac{\gamma d_j^3}{\rho_1} \right)^{1/2} \quad (3)$$

For sufficiently large flow rates Q compared to Q_{min} , the simplified averaged momentum equation in the axial direction can be expressed as

5

$$\frac{d}{dz} \left(\frac{\rho_1 Q^2}{2\pi^2 \xi^4} \right) = \frac{dP_g}{dz} + \frac{2\tau_s}{\xi}, \quad (4)$$

where one can identify the two driving forces for the liquid flow on the right-hand side. This equation can be integrated provided the following simplification is made: if one uses a thin plate with thickness L of the order or smaller than the hole's diameter D (which minimizes downstream perturbations in the gas flow), the pressure gradient up to the hole exit is on the average much larger than the viscous shear term $2\tau_s/\xi$ owing to the surface stress. On the other hand, the axial viscous term is of the order $O[\mu^2 Q/D^2 d_j^2]$, since the hole diameter D is actually the characteristic distance associated with the gas flow at the hole's entrance in both the radial and axial directions. This term is very small compared to the pressure gradient in real situations, provided that $\Delta P_g \gg \mu^2/D^2 \rho_1$ (which holds, e.g., for liquids with viscosities as large as 100 cpoises, using hole diameters and pressure drops as small as $D \sim 10 \mu\text{m}$ and $\Delta P_g \geq 100$ mbar). The neglect of all viscous terms in Eq. (4) is then justified. Notice that in this limit on the liquid flow is *quasi-isentropic* in the average (the liquid almost follows Bernoulli equation) as opposed to most micrometric extensional flows. Thus, integrating (4) from the stagnation regions of both fluids up to the exit, one obtains a *simple* and *universal* expression for the jet diameter at the hole exit:

15

20

$$d_j \approx \left(\frac{8\rho_1}{\pi^2 \Delta P_g} \right)^{1/4} Q^{1/2}, \quad (5)$$

which for a given pressure drop ΔP_g is *independent* of geometrical parameters (hole and tube diameters, tube-hole distance, etc.), liquid and gas viscosities, and liquid-gas surface tension. This diameter remains almost constant up to the breakup point since the gas pressure after the exit remains constant.

5

MONODISPERSE PARTICLES

Above the stable microjet undergoing "supercritical flow" is described and it can be seen how this aspect of the invention can be made use of in a variety of industrial applications -- particularly where the flow of liquid through small holes creates a clogging problem. An
10 equally important aspect of the invention is obtained after the microjet leaves the pressure chamber.

When the microjet exits the pressure chamber the liquid pressure P_l becomes (like the gas pressure P_g) almost constant in the axial direction, and the jet diameter remains almost constant up to the point where it breaks up by capillary instability. Defining a Weber number
15 $We = (\rho_g v_g^2 d_j) / \gamma \approx 2 \Delta P_g d_j / \gamma$ (where v_g is the gas velocity measured at the orifice), below a certain experimental value $We_c \sim 40$ the breakup mode is axisymmetric and the resulting droplet stream is characterized by its *monodispersity* provided that the fluctuations of the gas flow do not contribute to droplet coalescence (these fluctuations occur when the gas stream reaches a fully developed turbulent profile around the liquid jet breakup region). Above this
20 We_c value, sinuous nonaxisymmetric disturbances, coupled to the axisymmetric ones, become apparent. For larger We numbers, the nonlinear growth rate of the sinuous disturbances seems to overcome that of the axisymmetric disturbances. The resulting spray shows significant polydispersity in this case. Thus, it can be seen that by controlling parameters to keep the resulting Weber number to 40 or less, allows the particles formed to be all substantially the
25 same size. The size variation is about $\pm 3\%$ to $\pm 30\%$ and move preferably $\pm 3\%$ to $\pm 10\%$. These particles can have a desired size e.g. 0.1 microns to 50 microns.

The shed vorticity influences the breakup of the jet and thus the formation of the particles. Upstream from the hole exit, in the accelerating region, the gas stream is laminar. Typical values of the Reynolds number range from 500 to 6000 if a velocity of the order of
30 the speed of sound is taken as characteristic of the velocity of the gas. Downstream from the hole exit, the cylindrical mixing layer between the gas stream and the stagnant gas becomes unstable by the classical Kelvin-Helmholtz instability. The growth rate of the thickness of this

layer depends on the Reynolds number of the flow and ring vortices are formed at a frequency of the order of v_g/D , where D is the hole diameter. Typical values of v_g and D as those found in our experimental technique lead to frequencies of the order of MHz which are comparable to the frequency of drop production (of order of t_b^{-1}).

5 Given the liquid flow rate and the hole diameter, a resonance frequency which depends on the gas velocity (or pressure difference driving the gas stream) can be adjusted (*tuned*) in such a way that vortices act as a forcing system to excite perturbations of a determined wavelength on the jet surface. Experimental results obtained clearly illustrates the different degree of coupling between the two gas-liquid coaxial jets. In one set of
 10 experimental results the particle sizes are shown to have a particle size of about 5.7 microns with a standard deviation of 12%. This results when the velocity of the gas has been properly tuned to minimize the dispersion in the size of droplets resulting from the jet breakup. In this case, the flow rate of the liquid jet and its diameter are $0.08 \mu\text{l s}^{-1}$ and $3 \mu\text{m}$, respectively. Data have been collected using a MASTERSIZER from MALVERN Instruments. As the degree of
 15 coupling decreases, perturbations at the jet surface of different wavelengths become excited and, as it can be observed from the size distributions, the dispersion of the spray increases.

It is highly desirable in a number of different industrial applications to have particles which are uniform in size or to create aerosols of liquid particles which are uniform in size. For example, particles of a liquid formation containing a pharmaceutically active drug
 20 could be created and designed to have a diameter of about 2 microns $\pm 3\%$. These particles could be inhaled into the lungs of a patient for intrapulmonary drug delivery. Moreover, particle size can be adjusted to target a particular area of the respiratory tract.

Upstream of the orifice exit the gas flow should be laminar in order to avoid a turbulent regime - turbulent fluctuations in the gas flow which have a high frequency and
 25 would perturb the liquid-gas interface. The Reynolds numbers reached at the orifice are

$$Re = \frac{v_g d_0}{\nu_g} \sim 4000$$

where ν_g is the kinematic viscosity of the gas. Even though this number is quite high, there are large pressure gradients downstream (a highly convergent geometry), so that a turbulent regime is very unlikely to develop.

The essential difference from existing pneumatic atomizers (which possess large Weber numbers) and the present invention is that the aim of the present invention is not to rupture the liquid-gas interface but the opposite, i.e. to increase the stability of the interface until a capillary jet is obtained. The jet, which will be very thin provided the pressure drop
5 resulting from withdrawal is high enough, splits into drops the sizes of which are much more uniform than those resulting from disorderly breakage of the liquid-gas interface in existing pneumatic atomizers.

The proposed atomization system obviously requires delivery of the liquid to be atomized and the gas to be used in the resulting spray. Both should be fed at a rate ensuring
10 that the system lies within the stable parameter window. Multiplexing is effective when the flow-rates needed exceed those on an individual cell. More specifically, a plurality of feeding sources or feeding needles may be used to increase the rate at which aerosols are created. The flow-rates used should also ensure the mass ratio between the flows is compatible with the specifications of each application.

15 The gas and liquid can be dispensed by any type of continuous delivery system (*e.g.* a compressor or a pressurized tank the former and a volumetric pump or a pressurized bottle the latter). If multiplexing is needed, the liquid flow-rate should be as uniform as possible among cells; this may entail propulsion through several capillary needles, porous media or any other medium capable of distributing a uniform flow among different feeding points.

20 Each individual atomization device should consist of a feeding point (a capillary needle, a point with an open microchannel, a microprotuberance on a continuous edge, *etc.*) 0.002-2 mm (but, preferentially 0.01-0.4 mm) in diameter, where the drop emerging from the microjet can be anchored, and a small orifice 0.002-2 mm (preferentially 0.01-0.25 mm) in diameter facing the drop and separated 0.01-2 mm (preferentially 0.2-0.5 mm) from the
25 feeding point. The orifice communicates the withdrawal gas around the drop, at an increased pressure, with the zone where the atomizate is produced, at a decreased pressure. The atomizer can be made from a variety of materials (metal, polymers, ceramics, glass).

Figure 1 depicts a tested prototype where the liquid to be atomized is inserted through one end of the system 2 and the propelling gas is introduced via the special inlet 4 in
30 the pressure chamber 3. The prototype was tested at gas feeding rates from 100 to 2000 mBar above the atmospheric pressure P_α at which the atomized liquid was discharged. The whole enclosure around the feeding needle 1 was at a pressure $P_0 > P_\alpha$. The liquid feeding pressure,

P_i , should always be slightly higher than the gas propelling pressure, P_o . Depending on the pressure drop in the needle and the liquid feeding system, the pressure difference ($P_i - P_o > 0$) and the flow-rate of the liquid to be atomized, Q , are linearly related provided the flow is laminar - which is indeed the case with this prototype. The critical dimensions are the distance from the needle to the plate (H), the needle diameter (D_o), the diameter of the orifice through which the microjet is discharged (d_o) and the axial length, e , of the orifice (*i.e.* the thickness of the plate where the orifice is made). In this prototype, H was varied from 0.3 to 0.7 mm on constancy of the distances ($D_o = 0.45$ mm, $d_o = 0.2$ mm) and $e = 0.5$ mm. The quality of the resulting spray did not vary appreciably with changes in H provided the operating regime (*i.e.* stationary drop and microjet) was maintained. However, the system stability suffered at the longer H distances (about 0.7 mm). The other atomizer dimensions had no effect on the spray or the prototype functioning provided the zone around the needle (its diameter) was large enough relative to the feeding needle. As explained further below it is possible to obtain a stable capillary microjet which does not disassociate into a monodisperse aerosol. However, by adjusting parameters which relate to the Weber number a stable microjet is formed which disassociates to monodisperse aerosol.

WEBER NUMBER

Adjusting parameters to obtain a stable capillary microjet and control its breakup into monodisperse particle is governed by the Weber number and the liquid-to-gas velocity ratio or α which equal V_l/V_g . The Weber number or "We" is defined by the following equation:

$$We = \frac{\rho_g V_g^2 d}{\gamma}$$

wherein ρ_g is the density of the gas, d is the diameter of the stable microjet, γ is the liquid-gas surface tension, and V_g^2 is the velocity of the gas squared.

When carrying out the invention the parameters should be adjusted so that the Weber number is greater than 1 in order to produce a stable capillary microjet. However, to obtain a particle dispersion which is monodisperse (*i.e.* each particle has the same size ± 3 to $\pm 30\%$) the parameters should be adjusted so that the Weber number is less than about 40. The

monodisperse aerosol is obtained with a Weber number in a range of about 1 to about 40 ($1 \leq We \leq 40$).

OHNESORGE NUMBER

5 A measure of the relative importance of viscosity on the jet breakup can be estimated from the Ohnesorge number defined as the ratio between two characteristic times: the viscous time t_v and the breaking time t_b . The breaking time t_b is given by [see Rayleigh (1878)]

$$t_b \sim \left(\frac{\rho d^2}{\gamma} \right)^{1/2}. \quad (2)$$

Perturbations on the jet surface are propagated inside by viscous diffusion in times t_v of the order of

$$t_v \sim \rho d^2 / \mu_1, \quad (3)$$

10 where μ_1 is the viscosity of the liquid. Then, the Ohnesorge number, Oh, results

$$Oh = \frac{\mu_1}{(\rho \gamma d)^{1/2}}. \quad (4)$$

If this ratio is much smaller than unity viscosity plays no essential role in the phenomenon under consideration. Since the maximum value of the Ohnesorge number in actual experiments conducted is as low as 3.7×10^{-2} , viscosity plays no essential role during the process of jet breakup.

15

EMBODIMENT OF FIGURE 2

A variety of configurations of components and types of fluids will become apparent to those skilled in the art upon reading this disclosure. These configurations and fluids are encompassed by the present invention provided they can produce a stable capillary microjet of a
 20 first fluid from a source to an exit port of a pressure chamber containing a second fluid. The

stable microjet is formed by the first fluid flowing from the feeding source to the exit port of the pressure chamber being accelerated and stabilized by tangential viscous stress exerted by the second fluid in the pressure chamber on the surface of the first fluid forming the microjet. The second fluid forms a focusing funnel when a variety of parameters are correctly tuned or adjusted. For example, the speed, pressure, viscosity and miscibility of the first and second fluids are chosen to obtain the desired results of a stable microjet of the first fluid focused into the center of a funnel formed with the second fluid. These results are also obtained by adjusting or tuning physical parameters of the device, including the size of the opening from which the first fluid flows, the size of the opening from which both fluids exit, and the distance between these two openings.

The embodiment of Figure 1 can, itself, be arranged in a variety of configurations. Further, as indicated above, the embodiment may include a plurality of feeding needles. A plurality of feeding needles may be configured concentrically in a single construct, as shown in Figure 2.

The components of the embodiment of Figure 2 are as follows:

21. Feeding needle - tube or source of fluid.
22. End of the feeding needle used to insert the liquids to be atomized.
23. Pressure chamber.
24. Orifice used as gas inlet.
25. End of the feeding needle used to evacuate the liquid to be atomized.
26. Orifice through which withdrawal takes place.
27. Atomizate (spray) or aerosol.
28. First liquid to be atomized (inner core of particle).
29. Second liquid to be atomized (outer coating of particle).
30. Gas for creation of microjet.
31. Internal tube of feeding needle.
32. External tube of feeding needle.

D = diameter of the feeding needle; d = diameter of the orifice through which the microjet is passed; e = axial length of the orifice through which withdrawal takes place; H = distance from the feeding needle to the microjet outlet; γ = surface

tension; P_o = pressure inside the chamber; P_a = atmospheric pressure.

The embodiment of Figure 2 is preferably used when attempting to form a spherical particle of one substance coated by another substance. The device of Figure 2 is comprised of the same basic component as per the device of Figure 1 and further includes a second feeding source 32 which is positioned concentrically around the first cylindrical feeding source 31. The second feeding source may be surrounded by one or more additional feeding sources with each concentrically positioned around the preceding source. The outer coating may be used for a variety of purposes, including: coating particles to prevent small particles from sticking together; to obtain a sustained release effect of the active compound (e.g. a pharmaceutically active drug) inside, and/or to mask flavors; and to protect the stability of another compound (e.g. a pharmaceutically active drug) contained therein.

The process is based on the microsuction which the liquid-gas or liquid-liquid interphase undergoes (if both are immiscible), when said interphase approaches a point beginning from which one of the fluids is suctioned off while the combined suction of the two fluids is produced. The interaction causes the fluid physically surrounded by the other to form a capillary microjet which finally breaks into spherical drops. If instead of two fluids (gas-liquid), three or more are used that flow in a concentric manner by injection using concentric tubes, a capillary jet composed of two or more layers of different fluids is formed which, when it breaks, gives rise to the formation of spheres composed of several approximately concentric spherical layers of different fluids. The size of the outer sphere (its thickness) and the size of the inner sphere (its volume) can be precisely adjusted. This can allow the manufacture of coated particles for a variety of end uses. For example the thickness of the coating can be varied in different manufacturing events to obtain coated particles which have gradually decreasing thicknesses to obtain a controlled release effect of the contents, e.g. a pharmaceutically active drug. The coating could merely prevent the particles from degrading, reacting, or sticking together.

The method is based on the breaking of a capillary microjet composed of a nucleus of one liquid or gas and surrounded by another or other liquids and gases which are in a concentric manner injected by a special injection head, in such a way that they form a stable capillary microjet and that they do not mix by diffusion during the time between when the microjet is formed and when it is broken. When the capillary microjet is broken into spherical

drops under the proper operating conditions, which will be described in detail below, these drops exhibit a spherical nucleus, the size and eccentricity of which can be controlled.

In the case of spheres containing two materials, the injection head 25 consists of two concentric tubes with an external diameter on the order of one millimeter. Through the internal tube 31 is injected the material that will constitute the nucleus of the microsphere, while between the internal tube 31 and the external tube 32 the coating is injected. The fluid of the external tube 32 joins with the fluid of tube 31 as the fluids exit the feeding needle, and the fluids (normally liquids) thus injected are accelerated by a stream of gas that passes through a small orifice 24 facing the end of the injection tubes. When the drop in pressure across the orifice 24 is sufficient, the liquids form a completely stationary capillary microjet, if the quantities of liquids that are injected are stationary. This microjet does not touch the walls of the orifice, but passes through it wrapped in the stream of gas or funnel formed by gas from the tube 32. Because the funnel of gas focuses the liquid, the size of the exit orifice 26 does not dictate the size of the particles formed.

When the parameters are correctly adjusted, the movement of the liquid is uniform at the exit of the orifice 26 and the viscosity forces are sufficiently small so as not to alter either the flow or the properties of the liquids; for example, if there are biochemical molecular specimens having a certain complexity and fragility, the viscous forces that would appear in association with the flow through a micro-orifice might degrade these substances.

Figure 2 shows a simplified diagram of the feeding needle 21, which is comprised of the concentric tubes 30, 31 through the internal and external flows of the fluids 28, 29 that are going to compose the microspheres comprised of two immiscible fluids. The difference in pressures $P_0 - P_\alpha$ ($P_0 > P_\alpha$) through the orifice 26 establishes a flow of gas present in the chamber 23 and which is going to surround the microjet at its exit. The same pressure gradient that moves the gas is the one that moves the microjet in an axial direction through the hole 26, provided that the difference in pressures $P_0 - P_\alpha$ is sufficiently great in comparison with the forces of surface tension, which create an adverse gradient in the direction of the movement.

There are two limitations for the minimum sizes of the inside and outside jets that are dependent (a) on the surface tensions γ_1 of the outside liquid 29 with the gas 30 and γ_2 of the outside liquid 29 with the inside liquid 28, and (b) on the difference in pressures $\Delta P = P_0 - P_\alpha$ through the orifice 26. In the first place, the jump in pressures ΔP must be sufficiently

great so that the adverse effects of the surface tension are minimized. This, however, is attained for very modest pressure increases: for example, for a 10 micron jet of a liquid having a surface tension of 0.05 N/m (tap water), the necessary minimum jump in pressure is in the order of $0.05 \text{ (N/m)} / 0.00001 \text{ m} = \Delta P = 50 \text{ mBar}$. But, in addition, the breakage of the microjet must be regular and axilsymmetric, so that the drops will have a uniform size, while the extra pressure ΔP cannot be greater than a certain value that is dependent on the surface tension of the outside liquid with the gas γ_1 and on the outside diameter of the microjet. It has been experimentally shown that this difference in pressures cannot be greater than 20 times the surface tension γ_1 divided by the outside radius of the microjet.

Therefore, given some inside and outside diameters of the microjet, there is a range of operating pressures between a minimum and a maximum; nonetheless, experimentally the best results are obtained for pressures in the order of two to three times the minimum.

The viscosity values of the liquids must be such that the liquid with the greater viscosity μ_{\max} verifies, for a diameter d of the jet predicted for this liquid and a difference through the orifice ΔP , the inequality:

$$\mu_{\max} \leq \frac{\Delta P d^2 D}{Q}$$

With this, the pressure gradients can overcome the extensional forces of viscous resistance exerted by the liquid when it is suctioned toward the orifice.

Moreover, the liquids must have very similar densities in order to achieve the concentricity of the nucleus of the microsphere, since the relation of velocities between the liquids moves according to the square root of the densities $v_1/v_2 = (\rho_2/\rho_1)^{1/2}$ and both jets, the inside jet and the outside jet, must assume the most symmetrical configuration possible, which does not occur if the liquids have different velocities (Figure 2). Nonetheless, it has been experimentally demonstrated that, on account of the surface tension γ_2 between the two liquids, the nucleus tends to migrate toward the center of the microsphere, within prescribed parameters.

When two liquids and gas are used on the outside, the distance between the planes of the mouths of the concentric tubes can vary, without the characteristics of the jet being substantially altered, provided that the internal tube 31 is not introduced into the external one

32 more than one diameter of the external tube 32 and provided that the internal tube 31 does not project more than two diameters from the external tube 32. The best results are obtained when the internal tube 31 projects from the external one 32 a distance substantially the same as the diameter of the internal tube 31. This same criterion is valid if more than two tubes are used, with the tube that is surrounded (inner tube) projecting beyond the tube that surrounds (outer tube) by a distance substantially the same as the diameter of the first tube.

The distance between the plane of the internal tube 31 (the one that will normally project more) and the plane of the orifice may vary between zero and three outside diameters of the external tube 32, depending on the surface tensions between the liquids and with the gas, and on their viscosity values. Typically, the optimal distance is found experimentally for each particular configuration and each set of liquids used.

The proposed atomizing system obviously requires fluids that are going to be used in the resulting spray to have certain flow parameters. Accordingly, flows for this use must be:

- Flows that are suitable so that the system falls within the parametric window of stability. Multiplexing (i.e. several sets of concentric tubes) may be used, if the flows required are greater than those of an individual cell.

- Flows that are suitable so that the mass relation of the fluids falls within the specifications of each application. Of course, a greater flow of gas may be supplied externally by any means in specific applications, since this does not interfere with the functioning of the atomizer.

Therefore, any means for continuous supply of gas (compressors, pressure deposits, etc.) and of liquid (volumetric pumps, pressure bottles) may be used. If multiplexing is desired, the flow of liquid must be as homogeneous as possible between the various cells, which may require impulse through multiple capillary needles, porous media, or any other medium capable of distributing a homogeneous flow among different feeding points.

Each atomizing device will consist of concentric tubes 31, 32 with a diameter ranging between 0.05 and 2 mm, preferably between 0.1 and 0.4 mm, on which the drop from which the microjet emanates can be anchored, and a small orifice (between 0.001 and 2 mm in diameter, preferably between 0.1 and 0.25 mm), facing the drop and separated from the point of feeding by a distance between 0.001 and 2 mm, preferably between 0.2 and 0.5

mm. The orifice puts the suction gas that surrounds the drop, at higher pressure, in touch with the area in which the atomizing is to be attained, at lower pressure.

EMBODIMENT OF FIGURE 3

5 The embodiments of Figures 1 and 2 are similar in a number of ways. Both have a feeding piece which is preferably in the form of a feeding needle with a circular exit opening. Further, both have an exit port in the pressure chamber which is positioned directly in front of the flow path of fluid out of the feeding source. Precisely maintaining the alignment of the flow path of the feeding source with the exit port of the pressure
10 chamber can present an engineering challenge particularly when the device includes a number of feeding needles. The embodiment of Figure 3 is designed to simplify the manner in which components are aligned. The embodiment of Figure 3 uses a planar feeding piece, which by virtue of the withdrawal effect produced by the pressure difference across a small opening through which fluid is passed permits multiple microjets to be expelled through
15 multiple exit ports of a pressure chamber thereby obtaining multiple aerosol streams. Although a single planar feeding member is shown in Figure 3 it, of course, is possible to produce a device with a plurality of planar feeding members where each planar feeding member feeds fluid to a linear array of outlet orifices in the surrounding pressure chamber. In addition, the feeding member need not be strictly planar, and may be a curved feeding
20 device comprised of two surfaces that maintain approximately the same spatial distance between the two pieces of the feeding source. Such curved devices may have any level of curvature, e.g. circular, semicircular, elliptical, hemi-elliptical, etc.

The components of the embodiment of Figure 3 are as follows:

41. Feeding piece.
- 25 42. End of the feeding piece used to insert the fluid to be atomized.
43. Pressure chamber.
44. Orifice used as gas inlet.
45. End of the feeding needle used to evacuate the liquid to be atomized.
46. Orifices through which withdrawal takes place.
- 30 47. Atomizate (spray) or aerosol.
48. first fluid containing material to be atomized.
49. second fluid for creation of microjet.

50. wall of the propulsion chamber facing the edge of the feeding piece.

51. channels for guidance of fluid through feeding piece.

d_j = diameter of the microjet formed; ρ_A = liquid density of first fluid (48); ρ_B = liquid density of second fluid (49); v_A = velocity of the first liquid (48); v_B = velocity of the second liquid (49); e = axial length of the orifice through which withdrawal takes place; H = distance from the feeding needle to the microjet outlet; P_o = pressure inside the chamber;

Δp_g = change in pressure of the gas; P_a = atmospheric pressure; Q = volumetric flow rate

10 The proposed dispersing device consists of a feeding piece 41 which creates a planar feeding channel through which a where a first fluid 48 flows. The flow is preferably directed through one or more channels of uniform bores that are constructed on the planar surface of the feeding piece 41. A pressure chamber 43 that holds the propelling flow of a second liquid 49, houses the feeding piece 41 and is under a pressure above maintained
15 outside the chamber wall 50. One or more orifices, openings or slots (outlets) 46 made in the wall 52 of the propulsion chamber face the edge of the feeding piece. Preferably, each bore or channel of the feeding piece 41 has its flow path substantially aligned with an outlet 46.

Formation of the microjet and its acceleration are based on the abrupt pressure
20 drop resulting from the steep acceleration undergone by the second fluid 49 on passing through the orifice 46, similarly to the procedure described above for embodiments of Figures 1 and 2 when the second fluid 49 is a gas.

When the second fluid 49 is a gas and the first fluid 48 is a liquid, the microthread formed is quite long and the liquid velocity is much smaller than the gas velocity. In fact,
25 the low viscosity of the gas allows the liquid to flow at a much lower velocity; as a result, the microjet is actually produced and accelerated by stress forces normal to the liquid surface, i.e. pressure forces. Hence, one effective approximation to the phenomenon is to assume that the pressure difference established will result in the same kinetic energy per unit volume for both fluids (liquid and gas), provided gas compressibility effects are neglected.
30 The diameter d_j of the microjet formed from a liquid density ρ_1 that passes at a volumetric flow-rate Q through an orifice across which a pressure difference ΔP_g exists will be given by

$$d_j \cong \left(\frac{8\rho_l}{\pi^2 \Delta P_g} \right)^{1/4} Q^{1/2}$$

See Gañán-Calvo, Physical Review Letters, 80:285-288 (1998).

The relation between the diameter of the microjet, d_j , and that of the resulting drops, \bar{d} , depends on the ratio between viscous forces and surface tension forces on the liquid on the one hand, and between dynamic forces and surface tension forces on the gas on the other (*i.e.* on the Ohnesorge and Weber numbers, respectively) (Hinds (*Aerosol Technology*, John & Sons, 1982), Lefevre (*Atomization and Sprays*, Hemisphere Pub. Corp., 1989) and Bayvel & Orzechowski (*Liquid Atomization*, Taylor & Francis, 1993)). At moderate to low gas velocities and low viscosities the relation is roughly identical with that for capillarity instability developed by Rayleigh:

$$10 \quad \bar{d} = 1.89d_j$$

Because the liquid microjet is very long, at high liquid flow-rates the theoretical rupture point lies in the turbulent zone created by the gas jet, so turbulent fluctuations in the gas destabilize or rupture the liquid microjet in a more or less uneven manner. As a result, the benefits of drop size uniformity are lost.

15 On the other hand, when the second fluid 49 is a liquid and the first fluid 48 is a gas, the facts that the liquid is much more viscous and that the gas is much less dense provide that the gas microthread formed is much shorter; however, because its rupture zone is almost invariably located in a laminar flowing stream, dispersion in the size of the microbubbles formed is almost always small. At a volumetric gas flow-rate Q_g and a liquid overpressure

20 ΔP_l , the diameter of the gas microjet is given by:

$$d_j \cong \left(\frac{8\rho_g}{\pi^2 \Delta P_l} \right)^{1/4} Q_g^{1/2}$$

where ρ_g is the gas density. The low liquid velocity and the absence of relative velocities between the liquid and gas lead to the Rayleigh relation between the diameters of the microthread and those of the bubbles (*i.e.* $d = 1.89d_j$).

If both fluids 48, 49 are liquid and scarcely viscous, then their relative velocities will be given by their densities ratio:

$$\frac{V_A}{V_B} = \left(\frac{\rho_B}{\rho_A} \right)^{1/2}$$

The diameter of a microjet of the first liquid at a volumetric flow-rate of Q_A and an overpressure of ΔP_B will be given by

$$d_j \cong \left(\frac{8\rho_A}{\pi^2 \Delta P_B} \right)^{1/4} Q_A^{1/2}$$

- 5 At viscosities such that the velocities of both fluids 48, 49 will rapidly equilibrate in the microjet, the diameter of the microjet of the first liquid will be given by

$$d_j \cong \left(\frac{8\rho_B}{\pi^2 \Delta P_B} \right)^{1/4} Q_A^{1/2}$$

The proposed atomization system obviously requires delivery of the fluids 48, 49 to be used in the dispersion process at appropriate flow-rates. Thus:

- 10 (1) Both flow-rates should be adjusted for the system so that they lie within the stable parameter window.
- (2) The mass ratio between the flows should be compatible with the specifications of each application. Obviously, the gas flow-rate can be increased by using an external means in special applications (e.g. burning, drug
- 15 inhalation) since this need not interfere with the atomizer operation.
- (3) Therefore, the gas and liquid can be dispensed by any type of continuous delivery system (e.g. a compressor or

a pressurized tank the former and a volumetric pump or a pressurized bottle the latter).

- (4) The atomizer can be made from a variety of materials (metal, polymers, ceramics, glass).

5

SPECTROGRAPHIC ANALYSIS

An embodiment of the type shown in Figure 1 can be modified to provide an analytical device. A signal emitter (e.g. infrared) is positioned such that the signal is directed at and through the stable capillary microjet of fluid coming from the feeding source

10 1. A signal receiving component is positioned opposite the emitter. Thus, the flow stream out of the feeding needle 1 is positioned directly between the emitter and receiver. Two feeding needles may be used so that one can provide a flow stream of, for example, the solvent in which the material to be analyzed is dissolved. Two readings are made simultaneously and the reading of the solvent is subtracted away by microprocessor devices
15 of the type known to those skilled in the art to obtain a true analysis of only the material of interest.

In addition to analysis of any compound dissolved or suspended in a solvent the methodology can be used to analyze materials such as body fluids e.g. blood or urine. The methodology can be adapted to work in a wide range of different systems, e.g. see U.S.
20 Patent 5,126,022 issued June 30, 1992 and patents and publications cited therein. The present invention does not need to use electrical fields to move charged molecules as is required by many other systems. Thus, non-polar molecules can be moved, via the present invention, through the capillary microjet. Because of the manner in which the stable capillary microjet is formed and maintained materials such as large proteins, nucleotide
25 sequences, cells, and other biomaterials are not destroyed by physical stresses.

DRUG DELIVERY DEVICE

A device of the invention may be used to provide particles for drug delivery, e.g. the pulmonary delivery of aerosolized pharmaceutical compositions. The device would
30 produce aerosolized particles of pharmaceutically active drug for delivery to a patient by inhalation. The device is comprised of a liquid feeding source such as a channel to which formulation is added at one end and expelled through an exit opening. The feeding channel

is surrounded by a pressurized chamber into which gas is fed and out of which gas is expelled from an opening. The opening from which the gas is expelled is positioned directly in front of the flow path of liquid expelled from the feeding channel. Various parameters are adjusted so that pressurized gas surrounds liquid flowing out of the feeding channel in a manner so as to maintain a stable capillary microjet of liquid until the liquid exits the pressure chamber opening and is aerosolized. The aerosolized particles having a uniform diameter in the range of about 1 to 5 microns are inhaled into a patient's lungs and thereafter reach the patient's circulatory system.

10

PRODUCTION OF DRY PARTICLES

The method of the invention is also applicable in the mass production of dry particles. Such particles are useful in providing a highly dispersible dry pharmaceutical particles containing a drug suitable for pulmonary delivery. The particles formed of pharmaceutical are particularly useful in a dry powder inhaler due to the small size of the particles (e.g. 1, 2, 3, 4, or 5 microns in diameter) and conformity of size (e.g. 3 to 30% difference in diameter) from particle to particle. Such particles should improve dosage by providing accurate and precise amounts of dispersible particles to a patient in need of treatment. Dry particles are also useful because they may serve as a particle size standard in numerous applications.

20

For the formation of dry particles, the first fluid is preferably a liquid, and the second fluid is preferably a gas, although two liquids may also be used provided they are generally immiscible. Atomized particles within a desired size range (e.g., 1 micron to about 5 microns) The first fluid liquid is preferably a solution containing a high concentration of solute. Alternatively, the first fluid liquid is a suspension containing a high concentration of suspended matter. In either case, the liquid quickly evaporates upon atomization (due to the small size of the particles formed) to leave very small dry particles.

25

FUEL INJECTION APPARATUS

The device of the invention is useful to introduce fuel into internal combustion engines by functioning as a fuel injection nozzle, which introduces a fine spray of aerosolized fuel into the combustion chamber of the engine. The fuel injection nozzle has a unique fuel delivery system with a pressure chamber and a fuel source. Atomized fuel

30

particles within a desired size range (e.g., 5 micron to about 500 microns, and preferably between 10 and 100 microns) are produced from a liquid fuel formulation provided via a fuel supply opening. The fuel may be provided in any desired manner, e.g., forced through a channel of a feeding needle and expelled out of an exit opening of the needle.

- 5 Simultaneously, a second fluid contained in a pressure chamber which surrounds at least the area where the formulation is provided, e.g., surrounds the exit opening of the needle, is forced out of an opening positioned in front of the flow path of the provided fuel, e.g. in front of the fuel expelled from the feeding needle. Various parameters are adjusted to obtain a stable fuel-fluid interface and a stable capillary microjet of the fuel, which allows
- 10 formation of atomized fuel particles on exiting the opening of the pressurized chamber.

Fuel injectors of the invention have three significant advantages over prior injectors. First, fuel never contacts the periphery of the exit orifice from which it is emitted because the fuel stream is surrounded by a gas (e.g. air) which flows into the exit orifice. Thus, clogging of the orifice is eliminated or substantially reduced. Second, the fuel exits

15 the orifice and forms very small particles which are substantially uniform in size, thereby allowing faster and more controlled combustion of the fuel. Third, by using the methods described herein, the amount of energy needed to produce aerosolized particles of fuel is substantially less than that required by other methods.

20

MICROFABRICATION

Molecular assembly presents a 'bottom-up' approach to the fabrication of objects specified with incredible precision. Molecular assembly includes construction of objects using tiny assembly components, which can be arranged using techniques such as

5 microscopy, e.g. scanning electron microspray. Molecular self-assembly is a related strategy in chemical synthesis, with the potential of generating nonbiological structures with dimensions as small as 1 to 100 nanometers, and having molecular weights of 10^4 to 10^{10} daltons. Microelectro-deposition and microetching can also be used in microfabrication of objects having distinct, patterned surfaces.

10 Atomized particles within a desired size range (e.g., 0.001 micron to about 0.5 microns) can be produced to serve as assembly components to serve as building blocks for the microfabrication of objects, or may serve as templates for the self-assembly of monolayers for microassembly of objects. In addition, the method of the invention can employ an atomizate to etch configurations and/or patterns onto the surface of an object by

15 removing a selected portion of the surface.

AERATION OF WATER

More fish die from a lack of oxygen than any other cause. Fish exposed to low oxygen conditions become much more vulnerable to disease, parasites and infection, since

20 low oxygen levels will (1) lower the oxidation/reduction potential (ORP) (2) favor growth of disease causing pathogens and (3) disrupt the function of many commercially available biofilters. Moreover, stress will reduce the fish activity level, growth rate, and may interfere with proper development. A continuous healthy minimum of oxygen is approximately a 6 parts per million (ppm) oxygen:water ratio, which is approximately 24 grams of dissolved

25 oxygen per 1000 gallons of water. Fish consume on average 18 grams of oxygen per hour for every ten pounds of fish. Low level stress and poor feeding response can be seen at oxygen levels of 4-5 ppm. Acute stress, no feeding and inactivity can be seen at oxygen levels of 2-4 ppm, and oxygen levels of approximately 1-2 ppm generally result in death. These numbers are merely a guideline since a number of variable (e.g., water temperature,

30 water quality, condition of fish, level of other gasses, etc.) all may impact on actual oxygen needs.

Proper aeration depends primarily on two factors: the gentleness and direction of water flow and the size and amount of the air bubbles. With respect to the latter, smaller air bubbles are preferable because they (1) increase the surface area between the air and the water, providing a larger area for oxygen diffusion and (2) smaller bubbles stay suspended in water longer, providing a greater time period over which the oxygen may diffuse into the water.

The technology of the invention provides a method for aerating water for the proper growth and maintenance of fish. A device of the invention for such a use would provide an oxygenated gas, preferably air, as the first fluid, and a liquid, preferably water, as the second fluid. The air provided in a feeding source will be focused by the flow of the surrounding water, creating a stable cusp at the interface of the two fluids. The particles containing the gas nucleus, and preferably air nucleus, are expelled into the liquid medium where aeration is desired. When the first fluid of the invention is a liquid, and the second fluid is a gas, the inertia of the first fluid is low, and the gas abruptly decelerates very soon after it issues from the cusp of the attached droplet. In such an instance, the microjet is so short that it is almost indistinguishable from the stable cusp.

BUBBLES INTO LIQUID OR GAS

Figures 6 and 7 are useful in showing how bubbles may be formed in either a liquid (Figure 6) or a gas (Figure 7). In Figure 6 a tubular feeding source 71 is continually supplied with a flow of gas which forms a stable cusp 72 which is surrounded by the flow of liquid 73 in the pressure chamber 74 which is continually supplied with a flow of liquid 73. The liquid 73 flows out of the chamber 74 into a liquid 75 which may be the same as or different from the liquid 73.

The cusp 72 of gas narrows to a capillary supercritical flow 76 and then enters the exit opening 77 of the chamber 74. At a point 78 in the exit opening 77 the supercritical flow 76 begins to destabilize but remains as a critical capillary flow until leaving the exit opening 77. Upon leaving the exit opening 77 the gas stream breaks apart and forms bubbles 79 each of which are substantially identical to the others in shape and size. The uniformity of bubbles is such that one bubble differs from another (in terms of measured physical diameter) in an amount in a range of standard deviation of $\pm 0.01\%$ to $\pm 30\%$ with a preferred deviation being less than 1%. Thus, the uniformity in size of the bubbles is greater

than the uniformity of the particles formed as described above in connection with Figure 1 when liquid particles are formed.

Gas in the bubbles 79 will diffuse into the liquid 75. Smaller bubbles provide for greater surface area contact with the liquid 75. Smaller bubbles provide for greater surface area contact with the liquid 75 thereby allowing for a faster rate of diffusion than would occur if the same volume of gas were present in a smaller number of bubbles. For example, ten bubbles each containing 1 cubic mm of gas would diffuse gas into the liquid much more rapidly than one bubble containing 10 cubic mm of gas. Further, smaller bubbles rise to the liquid surface more slowly than larger bubbles. A slower rate of ascent in the liquid means that the gas bubbles are in contact with the liquid for a longer period of time thereby increasing the amount of diffusion of gas into the liquid. Thus, smaller bubbles could allow a greater amount of oxygen to diffuse into water (e.g., to sewage or where fish are raised) or allow a greater amount of a toxic gas (e.g., a radioactive gas) to diffuse into a liquid thereby concentrating the toxin for disposal. Because the bubbles are so uniform in size the amount of gas diffusing into the liquid can be uniformly calculated which is important in certain applications such as when diffusing CO₂ into carbonated drinks.

Figure 7 shows the same components as shown in Figure 6 except that the liquid 75 is replaced with a gas 80. When the stream of bubbles 79 disassociate the liquid 73 forms an outer spherical cover thereby providing hollow droplets 81 which will float in the gas 80. The hollow droplets 81 have a large physical or actual diameter relative to their aerodynamic diameter. Hollow droplets fall in air at a much slower rate compared to liquid droplets of the same diameter. Because the hollow droplets 81 do not settle or fall quickly in air they can be inhaled into the lungs. Eventually the hollow droplets 81 will burst and form many smaller particles which can be drawn even deeper into the lungs. Thus, it is understood that the aerodynamic diameter of the hollow droplets is very small compared to their actual physical diameter. The creation of hollow droplets 81 which burst and form very small particles is applicable in a wide range of different applications including internal combustion engines where the hollow droplets are formed using fuel (e.g., gasoline, diesel fuel, jet fuel) as the liquid 73 and injecting the hollow droplets 81 into the combustion chamber where the hollow droplets burst, form smaller particles and undergo combustion. The amount of fuel needed to create hollow droplets which burst and form a fine mist is minimal compared to any other existing pneumatic method.

EMULSIONS

Figure 8 is similar to Figures 6 and 7. However, rather than a gas 72 as in Figure 6 the feeding source 71 provides a stream of liquid 82 which may be miscible but is preferably immiscible in the liquid 73. Further the liquid 73 may be the same as or different from the liquid 75 but is preferably immiscible in the liquid 75. The creation of emulsions using such a configuration of liquids has applicability in a variety of fields particularly because the liquid particles formed can have a size in the range of from about 1 to about 200 microns with a standard deviation in size of one particle to another being as little as 0.01%. The size deviation of one particle to another can vary up to about 30% and is preferably less than $\pm 5\%$ and more preferably less than $\pm 1\%$.

In one application the configuration of Figure 8 is used in flow hemato-cytology sorting. The liquid 82 is a liquid such as blood, plasma, or other suitable flowable liquid containing cells of any type e.g., red and white blood cells, HIV infected cells, or cells from a biopsy which may be malignant. The liquid 73 is a liquid which can be the same or different from that of the liquid 82 but is preferably immiscible in the liquid 82 e.g., an oil which is immiscible in an aqueous liquid 82.

The system then operates to expel the liquid 82 out of the exit orifice 77 to form spheres 83 of liquid 82. Each sphere 83 has an actual physical diameter which deviates from other spheres 83 by a standard deviation of $\pm 0.01\%$ to $\pm 30\%$, preferably 10% or less and more preferably 1% or less. The size of the spheres 83 and flow rate of liquid 82 is controlled so that each sphere 83 contain a single particle (e.g. a single cell) to be examined. The stream of spheres 83 is caused to flow past a sensor and/or energy source of any desired type thereby allowing for cell-by-cell analysis of the sample of liquid 82 or more particularly particle-by-particle analysis of each particle (e.g., cell) in each sphere 83. The liquid 73 should be one that does not significantly interfere with analysis of any particle in a sphere 83.

Single cells in spheres 83 could be analyzed or treated via laser-sorting cell techniques in Micro Electro Mechanisms (MEMs).

In one embodiment the sorting allows for undesirable particles (e.g., infected or cancerous cells) to be identified and discarded. The remaining cells are then re-injected back into the patient (e.g., human) from which they were extracted. The size of the spheres 83 is not controlled by the size of the exit orifice 77 and as such clogging of the orifice 77 is

prevented and the spheres 83 can be made very small - approximately the diameter of a cell of the type being analyzed.

FOOD AND COSMETICS

5 Creating emulsions of small (1 micron to 200 microns) particles of uniform size (0.01% to 30% standard deviation) is important to the creation of high quality foods and cosmetics. An emulsions of small spheres 83 of oil is important to the taste, mouth feel or texture, and overall homogeneity of foods such as salad dressings, milk, mayonnaise and chocolate. Further, the system shown in Figure 8 is useful in the even distribution of color
10 and preservatives into the foods and cosmetics. By decreasing particle size and increasing uniformity smaller amounts of necessary (but undesirable) component can be added and obtain the same effect as if larger amounts were added via conventional technologies.

FUEL EMULSIONS

15 In Figure 8 the liquid 75 can be a gas (e.g., air) inside a combustion chamber of an internal combustion engine. The liquid 82 could be water which is surrounded by a second liquid 73 which is a hydrocarbon fuel. The system then forms particles 83 which have a water center and an outer coating of fuel. Such water/fuel particles will undergo combustion while decreasing both the overall combustion temperature and formation of undesirable
20 emissions without decreasing the compression rate or compromising the efficiency of the thermodynamic cycle of the engine. This system allows for temperature to be a readily adjustable parameter effected by the ratio of water to fuel. Adjusting the fuel/water ratio and thereby the temperature makes it possible to redesign the thermodynamic cycle thereby optimizing the ratio of power output to cleanliness.

25 The systems could also use two different types of fuel at the same time. A high octane fuel (gasoline) is used as the liquid 73 to surround a low octane fuel (desired fuel). Spheres 83 of cheaper lower octane fuel of any type are coated with a layer of more expensive high octane fuel of any type. When these spheres enter the combustion chamber the high octane fuel undergoes combustion first and causes a reaction which causes the
30 lower octane fuel to also undergo combustion. This system could be used with 92 octane gasoline coating an inner core of 87 octane gasoline to obtain substantially the same performance as with all 92 octanes but at a lower cost. Hollow droplets of fuel as in Figure

7 could also be created with the advantage of obtaining a fine mist of fuel when the droplets burst as shown in Figure 7.

EXAMPLES

5 The following examples are put forth so as to provide those of ordinary skill in the art with a complete disclosure and description of how to make and use the present invention, and are not intended to limit the scope of what the inventors regard as their invention nor are they intended to represent that the experiments below are all or the only experiments performed. Efforts have been made to ensure accuracy with respect to numbers used (e.g. amounts, temperature, etc.) but some experimental errors and deviations should be
10 accounted for. Unless indicated otherwise, parts are parts by weight, molecular weight is weight average molecular weight, temperature is in degrees Centigrade, and pressure is at or near atmospheric.

The properties of sixteen different liquids are provided in Table 1

15

TABLE 1: Liquids used and some of their physical properties at 24.5°C (ρ : kg/m³, μ : cpoise, γ : N/m). Also given, the symbols used in the plots.

	Liquid	ρ	μ	γ	Symbol
	Heptane	684	0.38	0.021	○
20	Tap Water	1000	1.00	0.056	◇
	Water + glycerol 90/10 v/v	1026	1.39	0.069	△
	Water + glycerol 80/20 v/v	1052	1.98	0.068	▽
	Isopropyl alcohol	755.5	2.18	0.021	×
	Water + glycerol 70/30 v/v	1078	2.76	0.067	○
25	Water + glycerol 60/40 v/v	1104	4.37	0.067	●
	Water + glycerol 50/50 v/v	1030	6.17	0.066	○
	1-Octanol	827	7.47	0.024	◇
	Water + glycerol 40/60 v/v	1156	12.3	0.065	△
	Water + glycerol 35/65 v/v	1167	15.9	0.064	▽
30	Water + glycerol 30/70 v/v	1182	24.3	0.064	×

Water + glycerol 25/75 v/v	1195	38.7	0.063	+
Propylene glycol	1026	41.8	0.036	●

The liquids of Table 1 were forced through a feeding needle of the type shown in Figure 1. The end 5 of the feeding needle had an internal radius R_o . The exit orifice 6 had a diameter D and the wall of the pressure chamber 3 had a thickness of L . Three different devices were tested having the following dimensions: ($D = 0.15, 0.2, \text{ and } 0.3 \text{ mm}$; $L = 0.1, 0.2 \text{ and } 0.35 \text{ mm}$; $R_o = 0.2, 0.4, \text{ and } 0.6 \text{ mm}$, respectively), and several distances H from the tube mouth to the orifice ranging from $H = 0.5 \text{ mm}$ to $H = 1.5 \text{ mm}$ have been used. The jet diameter was measured at the hole exit and was plotted as a function of the pressure difference ΔP_g and flow rate Q respectively. Although this technique allows for jet diameters even below one micron, larger flow rates and diameters have been used in this study to diminish the measuring errors.

In order to collapse all of the data, we define a reference flow rate Q_o and diameter d_o based on the minimal values, from expressions (3) and (5), that can be attained in stable regime for a given ΔP_g :

$$Q_o = \left(\frac{\gamma^4}{\rho_1 \Delta P_g^3} \right)^{1/2}, \quad d_o = \frac{\gamma}{\Delta P_g} \quad (6)$$

These definitions provide the advantage of a nondimensional expression for (5), as

$$d_j/d_o = (8/\pi^2)^{1/4} (Q/Q_o)^{1/2}, \quad (7)$$

which allows for a check for the validity of neglecting the surface tension term in (4) (i.e., Q/Q_o should be large).

Notice that if the measured d_j follows expression (5), the surface tension cancels out in (7). Also notice that $d_j/d_o \approx We/2$.

350 measured values of d_j/d_o versus Q/Q_o are plotted in Fig. 5. A continuous line represents the theoretical prediction (7), independent of liquid viscosity and surface tension. The use of different hole and tube diameters as well as tube-hole distances does not have any

appreciable influence on d_j . The collapse of the experimental data and the agreement with the simple theoretical model is excellent. Finally, the experimental values of Q are at least four times large than Q_0 (being in most cases several hundreds times larger), which justifies the neglect of the surface tension term in Eq. (4).

5 While the present invention has been described with reference to the specific embodiments thereof, it should be understood by those skilled in the art that various changes may be made and equivalents may be substituted without departing from the true spirit and scope of the invention. In addition, many modifications may be made to adapt a particular situation, material, composition of matter, process, process step or steps, to the objective,
10 spirit and scope of the present invention. All such modifications are intended to be within the scope of the claims appended hereto.

What is claimed is:

1. A stream of a first fluid characterized by forming a stable capillary microjet over a portion of the stream wherein the stable capillary microjet portion of the stream is formed by a second fluid moving at a velocity greater than that of the first fluid.

2. The stream of claim 1, wherein the first fluid is a liquid and the second fluid is a gas.

3. The stream of claim 2, wherein stable capillary microjet comprises a diameter d_j at a given point A in the stream characterized by the formula:

$$d_j \cong \left(\frac{8\rho_l}{\pi^2 \Delta P_g} \right)^{1/4} Q^{1/2}$$

wherein d_j is the diameter of the stable microjet, \cong indicates approximately equally to where an acceptable margin of error is $\pm 10\%$, ρ_l is the density of the liquid and ΔP_g is change in gas pressure of gas surrounding the stream at the point A.

4. The stream of claim 3, wherein d_j is a diameter in a range of about 1 micron to about 1 mm;

wherein the stable capillary jet portion has a length in a range of from about 1 micron to about 50 mm;

wherein the stable capillary microjet is maintained, at least in part, by tangential viscous stresses exerted by the gas on a surface of the jet in an axial direction of the jet; and

wherein the microjet is further characterized by a slightly parabolic axial velocity profile.

5. A monodisperse aerosol of liquid particles in air, the particles characterized by having the same diameter with a deviation in diameter from one particle to another wherein a given particle in the aerosol has a diameter in a range of about 0.1 micron

to about 100 microns and other particles in the aerosol have the same diameter as the given particle with a deviation of about $\pm 3\%$ to about $\pm 10\%$.

6. A stream of a liquid characterized by forming a stable capillary microjet over a portion of the stream wherein the stable capillary microjet position of the stream is formed by a gas moving in a direction substantially parallel to that of the stream of liquid wherein the liquid stream and gas are moved by the application of physical pressure.

7. The stream of claim 6, wherein the Weber number is in a range of from about 1 to about 40 wherein the Weber number is defined by the following equation:

$$We = \frac{\rho_g V_g^2 d}{\gamma}$$

wherein ρ_g is the density of the gas, d is the diameter of the stable microjet, γ is the liquid-gas surface tension, and V_g^2 is the velocity of the gas squared.

8. The stream of claim 7, wherein the Weber number is in a range of from about 5 to about 25; and

wherein Ohnesorge number is less than one, wherein the Ohnesorge number (Oh) is defined by

$$Oh = \frac{\mu_l}{(\rho_l \gamma d)^{1/2}}$$

wherein μ_l is the viscosity of liquid, ρ_l is the density of the liquid and d is the diameter of the stable capillary microjet.

9. A method of analyzing a compound in a liquid, comprising the steps of: applying physical pressure to force a first liquid through a channel of a feeding source in a manner which causes the first liquid to be expelled from an exit opening of the channel;

forcing a fluid selected from the group consisting of a gas and a second liquid which is immiscible with the first liquid through a pressure chamber in a manner which causes the fluid to exit the pressure chamber from an exit orifice in front of a flow path of the first liquid expelled from the exit opening of the channel, wherein a stable first liquid-fluid interface is maintained and the first liquid forms a stable capillary jet focused on the exit orifice of the pressure chamber;

5
10
15
20
25
30

emitting a plus of energy through the stable capillary jet;
receiving energy from the plus;
analyzing energy received to determine information regarding a compound in the first liquid.

10. The method of claim 9, wherein the energy is selected from the group consisting of infrared, ultra violet, x-ray, and LASAR; and

15
20
25
30

wherein the fluid is a gas and the stable capillary jet portion has a length in a range of from about 1 micron to about 50 mm and wherein the stable capillary microjet is maintained, at least in part, by tangential viscous stresses exerted by the gas on a surface of the jet in an axial direction of the jet.

11. The method of claim 10, wherein the first fluid comprises particles to be analyzed;

20
25
30

wherein the second fluid is a second liquid immiscible with the first liquid;
wherein the stable capillary jet disassociates into uniform spheres and each sphere contains a single particle of the first liquid.

12. The method of claim 11, wherein the particles are cells.

30

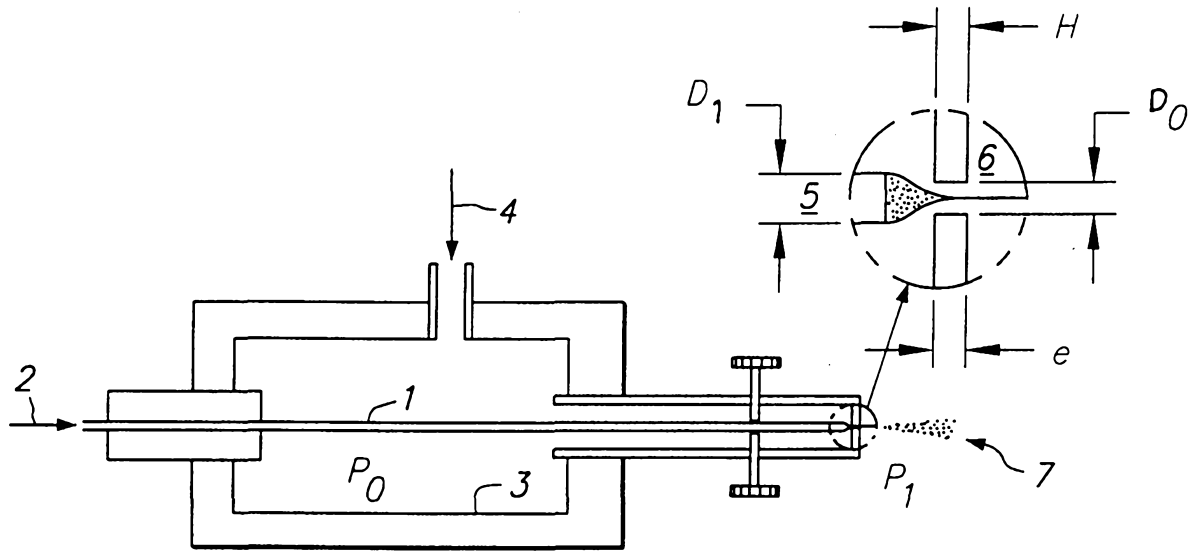

FIG. 1

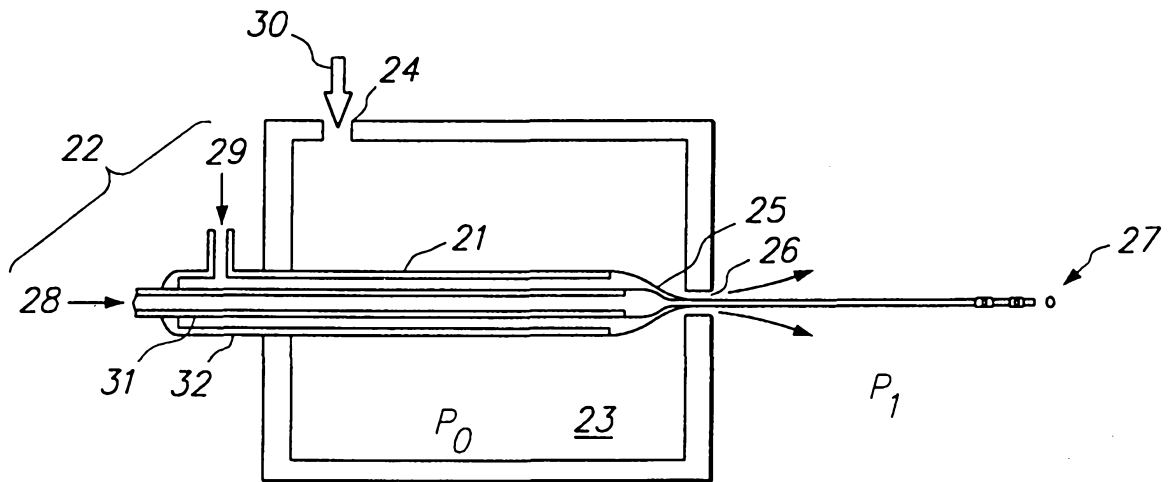

FIG. 2

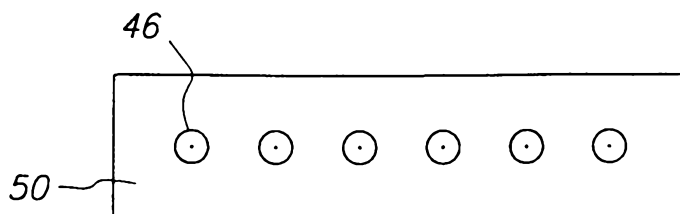

FIG. 3B

2/6

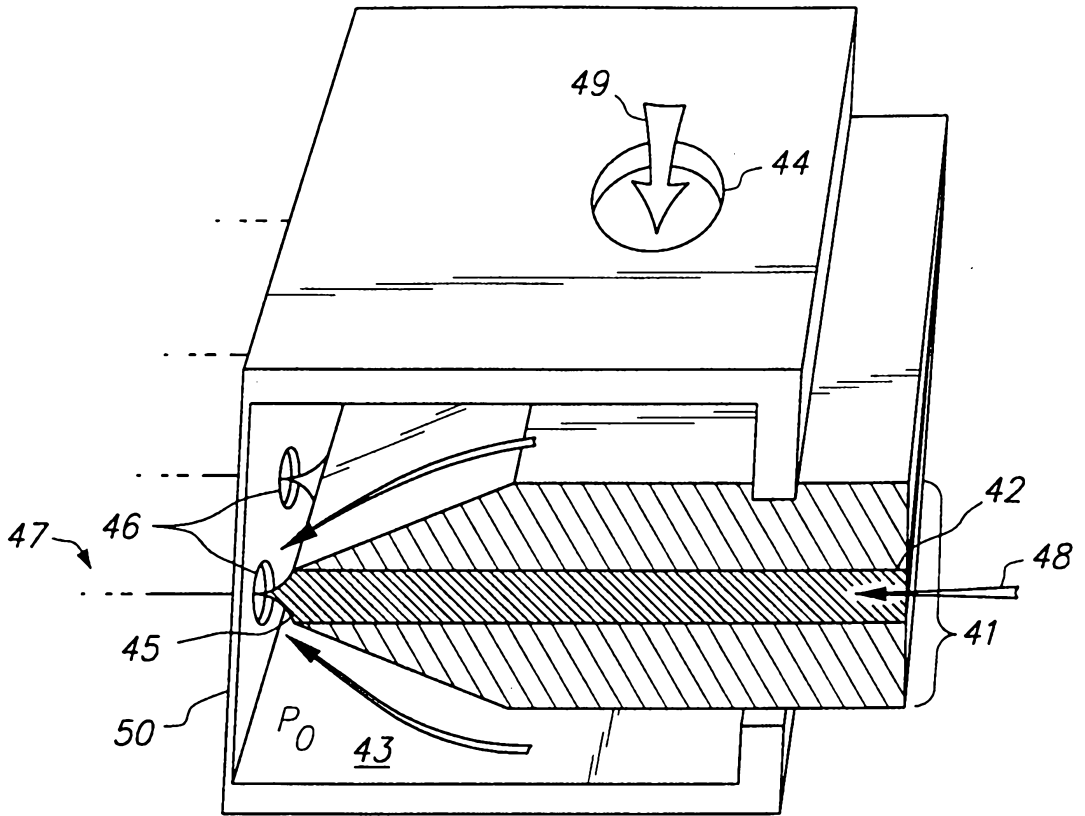

FIG. 3A

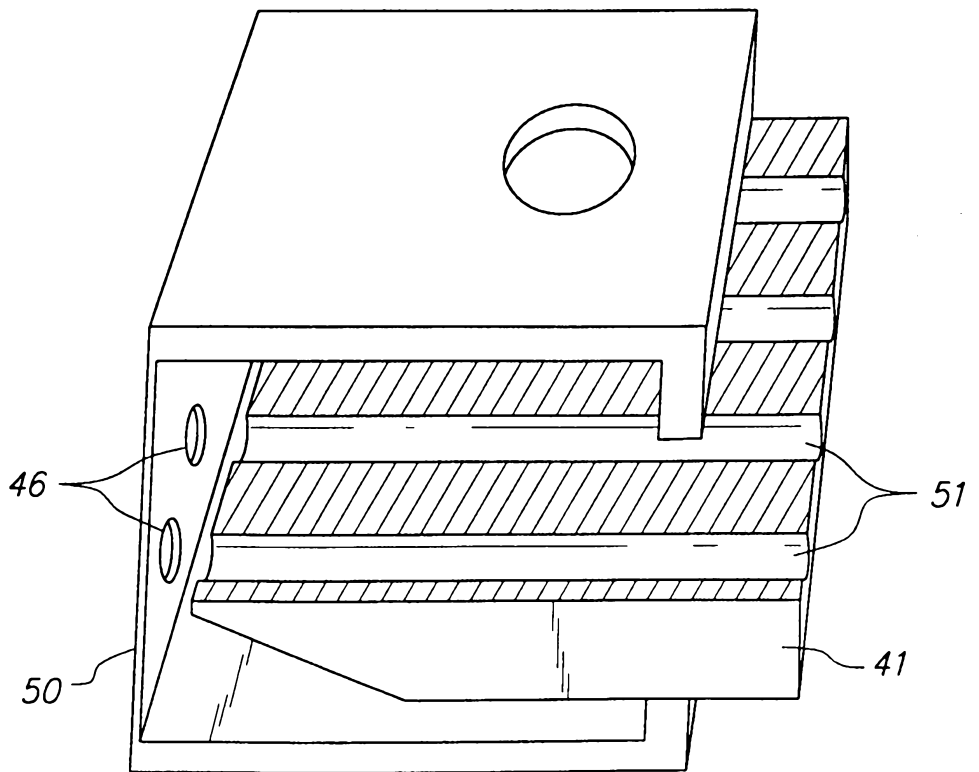

FIG. 3C

3/6

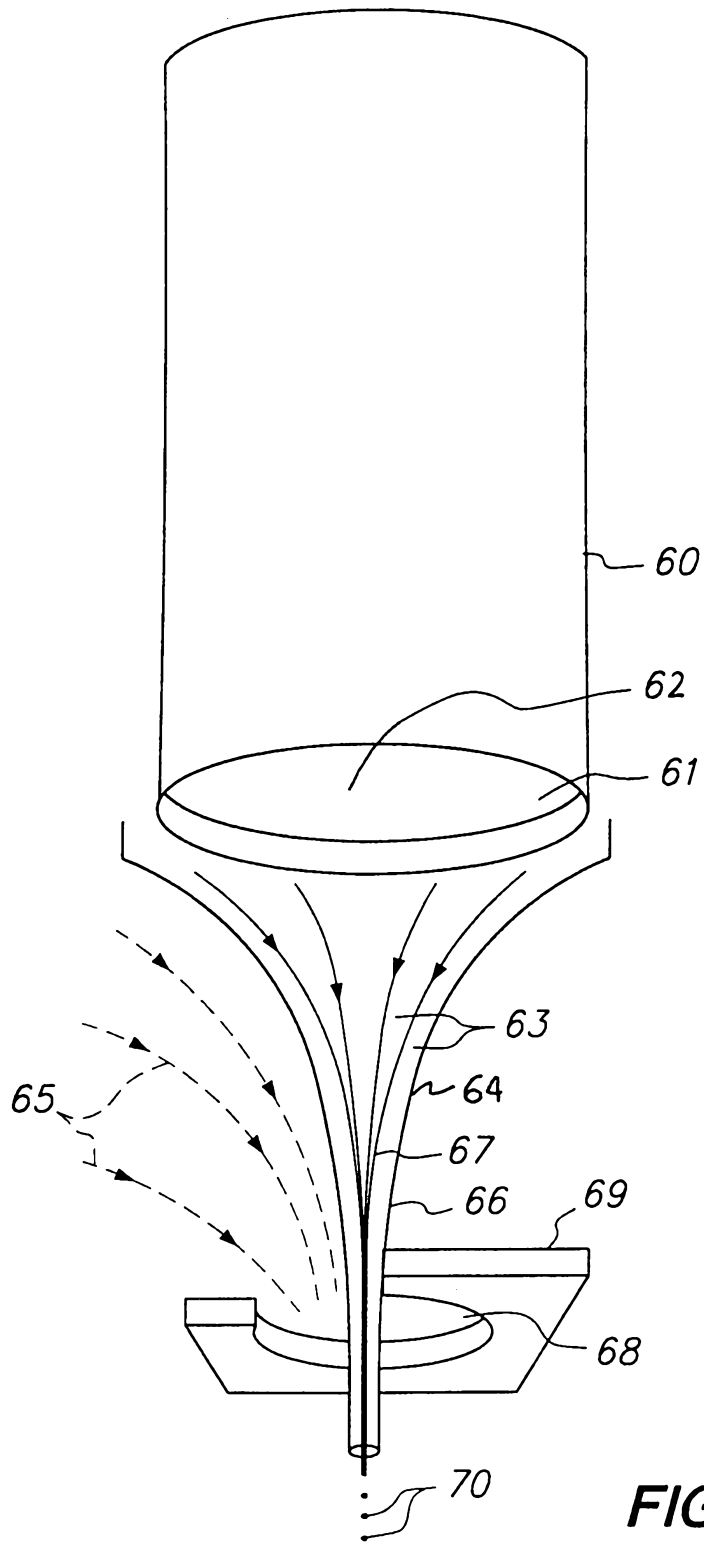
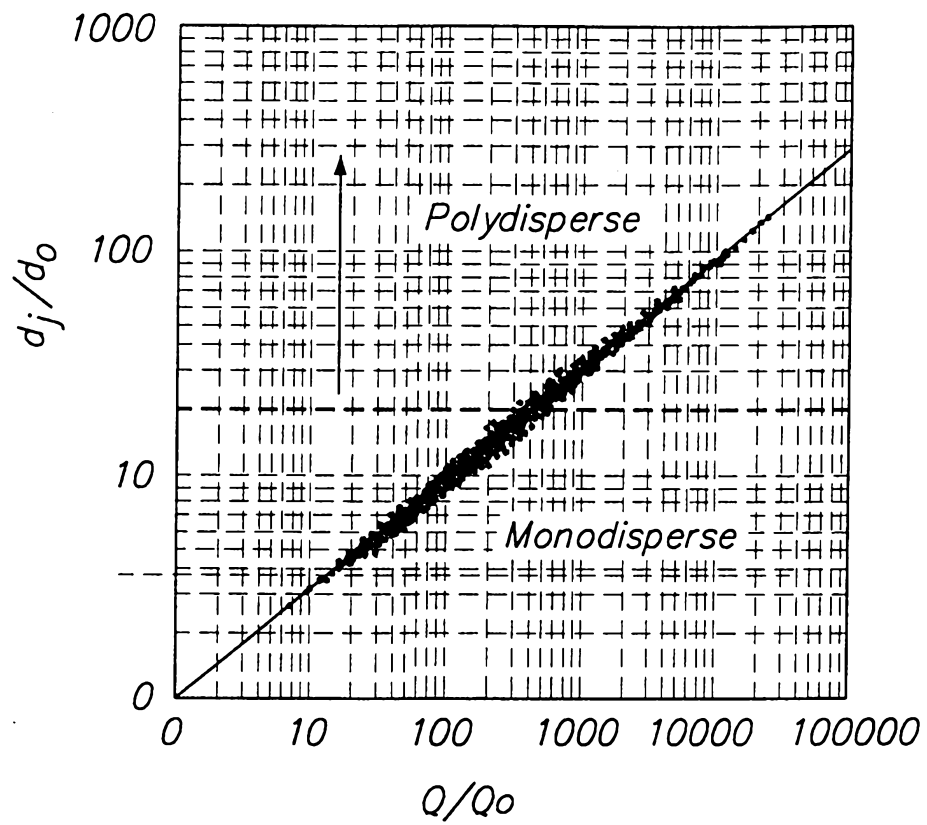

FIG. 4

4/6

**FIG. 5**

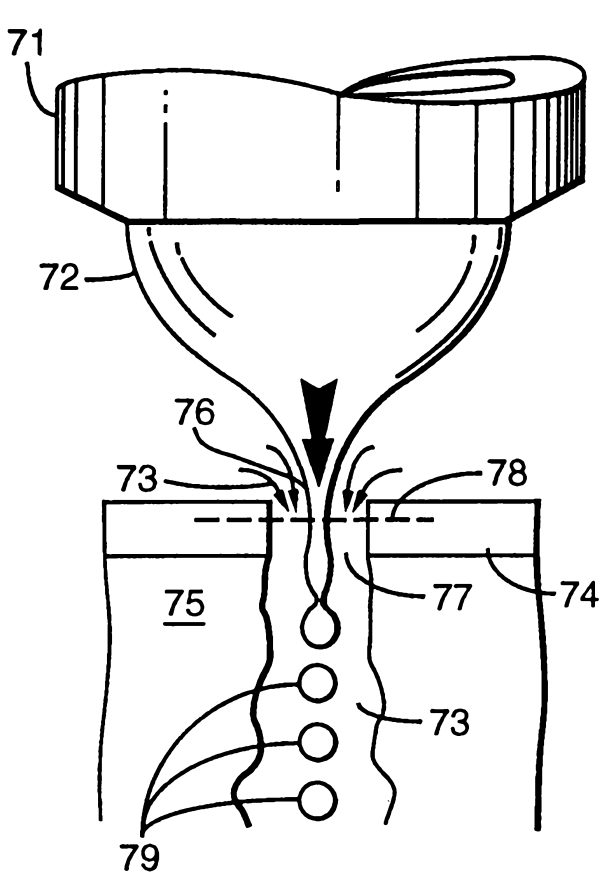

FIG. 6

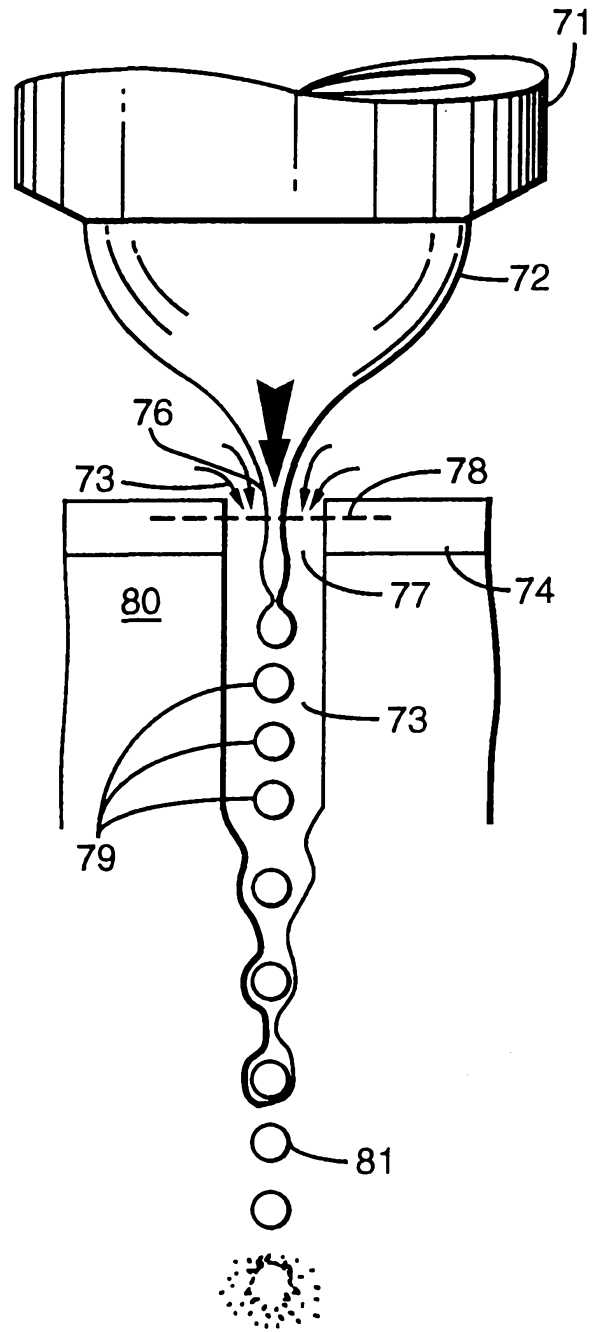

FIG. 7

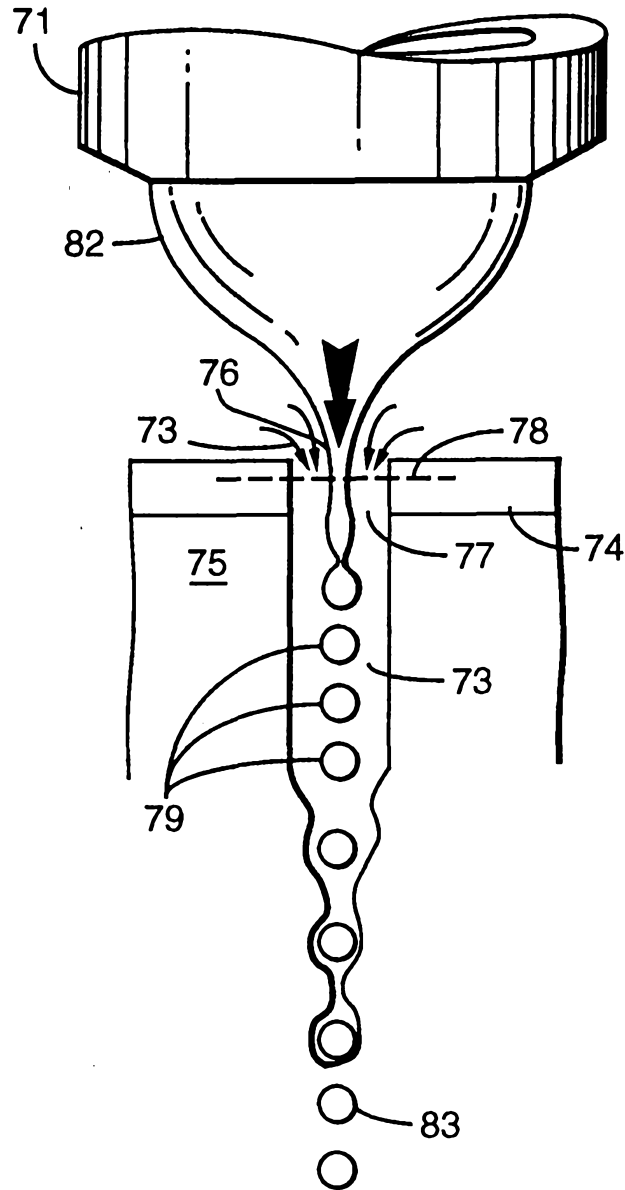

FIG. 8