

**(12) STANDARD PATENT**  
**(19) AUSTRALIAN PATENT OFFICE**

(11) Application No. **AU 2013303222 B2**

(54) Title  
**Devices and methods for cutting tissue**

(51) International Patent Classification(s)  
**A61B 17/32 (2006.01)**

(21) Application No: **2013303222**

(22) Date of Filing: **2013.01.04**

(87) WIPO No: **WO14/028046**

(30) Priority Data

(31) Number	(32) Date	(33) Country
<b>61/707,800</b>	<b>2012.09.28</b>	<b>US</b>
<b>61/684,598</b>	<b>2012.08.17</b>	<b>US</b>
<b>13/657,773</b>	<b>2012.10.22</b>	<b>US</b>

(43) Publication Date: **2014.02.20**

(44) Accepted Journal Date: **2017.10.12**

(71) Applicant(s)  
**Myromed, LLC**

(72) Inventor(s)  
**Dubois, Brian R.;Gordon, Alexander;Nielsen, James T.**

(74) Agent / Attorney  
**FB Rice Pty Ltd, L 23 44 Market St, Sydney, NSW, 2000, AU**

(56) Related Art  
**EP 0746245 B1**  
**US 2008/0319341 A1**  
**US 5429596 A**  
**WO 2012/003383 A1**  
**US 6113569 A**



- (51) International Patent Classification: *A61B 17/32* (2006.01)
- (21) International Application Number: PCT/US2013/020400
- (22) International Filing Date: 4 January 2013 (04.01.2013)
- (25) Filing Language: English
- (26) Publication Language: English
- (30) Priority Data:
 

61/684,598	17 August 2012 (17.08.2012)	US
61/707,800	28 September 2012 (28.09.2012)	US
13/657,773	22 October 2012 (22.10.2012)	US
- (63) Related by continuation (CON) or continuation-in-part (CIP) to earlier application:
 

US	13/657,773 (CIP)
Filed on	22 October 2012 (22.10.2012)
- (71) Applicant: LAURIMED, LLC [US/US]; 500 Arguello Street, Suite 100, Redwood City, California 94063 (US).
- (72) Inventors: DUBOIS, Brian, R.; 827 Piedmont Way, Redwood City, California 94062 (US). NIELSEN, James, T.; 1570 Portola Drive, San Francisco, California 94127 (US). GORDON, Alexander; 616 Harvard Ave, Apt. 1, Menlo Park, California 94025 (US).
- (74) Agents: GIOVANNETTI, Steven, M. et al.; Levine Bagade Han LLP, 2400 Geng Road, Suite 120, Palo Alto, CA 94303 (US).
- (81) Designated States (unless otherwise indicated, for every kind of national protection available): AE, AG, AL, AM, AO, AT, AU, AZ, BA, BB, BG, BH, BN, BR, BW, BY, BZ, CA, CH, CL, CN, CO, CR, CU, CZ, DE, DK, DM, DO, DZ, EC, EE, EG, ES, FI, GB, GD, GE, GH, GM, GT, HN, HR, HU, ID, IL, IN, IS, JP, KE, KG, KM, KN, KP, KR, KZ, LA, LC, LK, LR, LS, LT, LU, LY, MA, MD, ME, MG, MK, MN, MW, MX, MY, MZ, NA, NG, NI,

[Continued on next page]

(54) Title: DEVICES AND METHODS FOR CUTTING TISSUE

(57) Abstract: Various medical devices and methods for cutting, evacuating and/or performing work on tissue are provided. The devices and methods may utilize a reciprocating mechanism or motor powered by suction from a vacuum source. The medical devices and methods may be used on tissue in various regions of a patient's body and for treating various conditions, e.g., for performing a polypectomy.

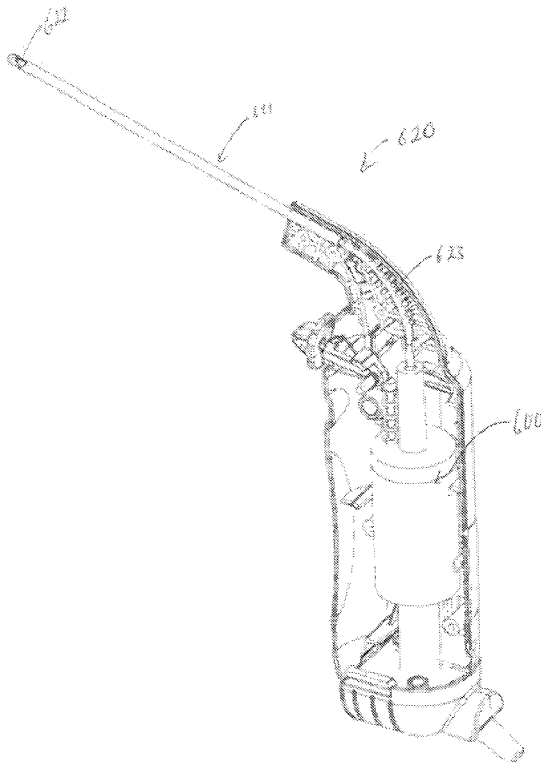

Fig. 12A

WO 2014/028046 A1

NO, NZ, OM, PA, PE, PG, PH, PL, PT, QA, RO, RS, RU, RW, SC, SD, SE, SG, SK, SL, SM, ST, SV, SY, TH, TJ, TM, TN, TR, TT, TZ, UA, UG, US, UZ, VC, VN, ZA, ZM, ZW.

SM, TR), OAPI (BF, BJ, CF, CG, CI, CM, GA, GN, GQ, GW, ML, MR, NE, SN, TD, TG).

**Declarations under Rule 4.17:**

— *as to applicant's entitlement to apply for and be granted a patent (Rule 4.17(ii))*

**Published:**

— *with international search report (Art. 21(3))*

**(84) Designated States** (*unless otherwise indicated, for every kind of regional protection available*): ARIPO (BW, GH, GM, KE, LR, LS, MW, MZ, NA, RW, SD, SL, SZ, TZ, UG, ZM, ZW), Eurasian (AM, AZ, BY, KG, KZ, RU, TJ, TM), European (AL, AT, BE, BG, CH, CY, CZ, DE, DK, EE, ES, FI, FR, GB, GR, HR, HU, IE, IS, IT, LT, LU, LV, MC, MK, MT, NL, NO, PL, PT, RO, RS, SE, SI, SK,

## DEVICES AND METHODS FOR CUTTING TISSUE

### CROSS-REFERENCE TO RELATED APPLICATIONS

[0001] This application claims the benefit of priority to U.S. Provisional Patent Application No. 61/684,598 filed August 17, 2012 and U.S. Provisional Patent Application No. 61/707,800 filed September 28, 2012, the contents of which are incorporated herein by reference in their entirety. This application is also a continuation-in-part of U.S. Patent Application No. 13/657,773 filed October 22, 2012 which is a continuation of U.S. Patent Application No. 13/550,407 filed July 16, 2012, now U.S. Patent No. 8,292,909, which is a continuation of U.S. Patent Application No. 13/174,416 filed June 30, 2011, now U.S. Patent No. 8,298,254, which claims the benefit of priority to U.S. Provisional Patent Application No. 61/360,429 filed June 30, 2010 and U.S. Provisional Patent Application Serial No. 61/377,883 filed August 27, 2010, the contents of which are incorporated herein by reference in their entirety.

### FIELD OF THE INVENTION

[0002] The present devices and methods relate generally to medical devices and methods for cutting, evacuating and/or performing work on tissue in various regions of a patient's body.

### BACKGROUND

[0003] Many common medical devices perform the function of resecting tissue. Suction, supplied by an external vacuum source is often used to evacuate tissue from the operative site.

[0004] Medical devices which cut and evacuate tissue are used in a variety of procedures, including ear, nose, and throat surgery, gynecological surgery, spinal surgery, ophthalmic surgery, and many other applications. Depending on the procedure, the evacuated tissue may be collected for pathological analysis.

[0005] When applied to ear, nose, and throat surgery, tissue resecting devices are commonly referred to as microdebriders.

[0006] Tissue incision may be performed by either a rotating cutter (unidirectional or oscillating) or a reciprocating cutter. In the case of a rotating cutter, an electric motor is



commonly used as the source of motion. In the case of a reciprocating cutter, motion may be produced by manual actuation, through a control such as a button or trigger, or powered actuation using pulsed or valved compressed air. Each of these power sources has distinct disadvantages when used to power a resecting medical device.

[0007] For example, when an electric motor is used to provide rotational motion of a cutter, the additional weight of the electric motor may cause operator fatigue. Wires from an external power supply are inconvenient to make the connections and it is inconvenient to have the wires attached to the device during use.

[0008] An electric motor increases the total cost of a device because of the relatively high cost of the motor itself and the cost of a power supply (in the case of an externally powered motor) or the cost of a recharging unit (when rechargeable batteries are used). The addition of electric motors makes sterilization of the device more difficult, e.g., because of the added mass to the device from the motors. Additionally, the presence of batteries reduces the sterilization options available to the manufacturer, due to the heat generated by certain sterilization techniques. The presence of batteries adds potentially toxic chemicals that present additional challenges related to toxicity, sterilization, and device disposal.

[0009] Medical devices that include electric motors are often made to be re-usable which requires a system for reprocessing the device. When using a manually actuated cutting device, the operator may experience fatigue from repeated actuations. Additionally, manual actuations can be performed only as quickly as the operator can actuate the cutter via mechanical input through a control and the time required to perform an adequate number of actuations may be excessive.

[0010] Electrically-powered microdebridors typically require an expensive capital investment in a power console that is separate from the handpiece. The capital cost of the power console, handpiece, and disposable blades makes procedures such as a nasal polypectomy and other procedures cost prohibitive in a doctor's clinic setting.

[0011] Existing microdebridors are typically built with a handle of the device in line with the shaft of the device, as a result, the handle and the operator's hand may interfere with an endoscope and/or the camera.

[0012] Existing microdebridors expose a cutting blade to the end of the device. This may be disadvantageous when the operator loses sight of the end of the device and accidentally cuts or damages structures that come into contact with it.

**[0013]** As a result of these limitations, it is impractical for Ear, Nose, and Throat physicians or other physicians to remove nasal and sinus polyps or other polyps or other tissue in an office or other setting using the current technology. Therefore, patients are left with the undesirable options of a course of steroid treatments to reduce the size of the polyps (with associated steroid side effects), removal of the polyps in an ambulatory surgery center (cost prohibitive and therefore rarely performed as a stand-alone procedure), or leaving the polyps untreated and dealing with the associated breathing obstruction.

**[0013]** Any discussion of documents, acts, materials, devices, articles or the like which has been included in the present specification is not to be taken as an admission that any or all of these matters form part of the prior art base or were common general knowledge in the field relevant to the present disclosure as it existed before the priority date of each of the appended claims.

#### BRIEF SUMMARY

**[0014]** Various medical devices and methods for cutting, evacuating and/or performing work on tissue in various regions of a patient's body are provided herein

**[0014A]** Throughout this specification the word "comprise", or variations such as "comprises" or "comprising", will be understood to imply the inclusion of a stated element, integer or step, or group of elements, integers or steps, but not the exclusion of any other element, integer or step, or group of elements, integers or steps.

**[0014B]** In an aspect, there is provided a medical device driven by a vacuum source, the device comprising:

a working end having an operable element, the operable element coupled to a mechanism comprising a drive piston, a valve, and a biasing component, such that when the mechanism is driven by the vacuum source, movement of a drive piston actuates the operable element;

wherein the drive piston is located in a chamber and is moveable within the chamber between a drive stroke and a return stroke;

wherein the valve is configured to alternately seal and vent a cross-hole in the drive piston, the cross-hole when vented allowing airflow across the drive piston and into at least a portion of the chamber; and

wherein the biasing component is positioned against the drive piston, wherein alternately sealing and venting the cross-hole in the drive piston causes the drive piston to cycle between the drive stroke and the return stroke.

**[0015]** Various cutting devices driven by various power sources are described herein. In certain variations, a vacuum powered tissue cutting device is provided. The device may include an elongate shaft having a proximal end, a distal end and a lumen defined therein. The distal end may include an opening for receiving tissue. A cutter may be positioned within the elongate shaft, wherein the cutter is configured to be actuated to cut tissue. A chamber may be coupled to the proximal end of the elongate shaft. The chamber may have a mechanism positioned therein, wherein the mechanism can be powered by suction created by a vacuum source such that the mechanism produces an actuating motion which causes the cutter to actuate, e.g., to reciprocate. In certain variations, a cutter positioned within the elongate shaft may be reciprocated past the opening in the elongate shaft to cut tissue in the opening.

**[0016]** In certain variations, a method of cutting and/or removing tissue from a subject may include advancing a cutting device next to, near or to a target tissue in the subject. The cutting device may have an elongate shaft and a cutter positioned within the elongate shaft. The cutting device may be powered using suction created by a vacuum source such that the cutting device produces an actuating motion, which causes the cutter to actuate, e.g., reciprocate, to cut tissue. The cut tissue may be evacuated using the suction created by the vacuum source or may be otherwise removed. In certain variations, the method of cutting and/or removing tissue may be utilized to perform a polypectomy or a discectomy.

**[0017]** In certain variations, an apparatus for cutting or scraping tissue in a subject may be provided. The apparatus may include an end effector, wherein the end effector

includes a scraping edge positioned on a distal end of the end effector. One or more scraping wings may be positioned at an angle relative to the scraping edge such that the scraping edge and scraping wings may be used to provide scraping motions in different directions.

**[0018]** In certain variations, devices, systems and methods for excising, cutting and/or evacuating tissue are provided. A variation of a device may include a cutter and a double action vacuum powered mechanism or motor in which vacuum is used to actively reciprocate a piston connected to the cutter. The vacuum powered motor may include a vacuum port connected to a vacuum source, a shuttle piston, a drive piston coupled to the shuttle piston, and a chamber for receiving the drive piston, the chamber having proximal and distal sides. The drive piston may be set into reciprocating motion through the creation of differential pressure on either side of the piston by alternating evacuation, through the vacuum port, within the two sides of the piston chamber. The motion of the drive piston may effect translation of the shuttle piston, causing the shuttle piston to alternate between positions of opening and closing the vacuum port to the proximal and distal sides of the piston chamber to alternate evacuation of each side of the chamber. The actuating motion, e.g., reciprocating motion, of the drive piston may be used to reciprocate or rotate the cutter.

**[0019]** In certain variations, a cutting or scraping component may be positioned or located at or near a distal end of a rigid or flexible end effector which may be utilized to excise, scrape or cut tissue. The end effector may be curved or straight. The end effector may include a shaft, a reciprocating cutter and/or a scraping edge positioned on the shaft or on the reciprocating cutter.

**[0020]** In certain variations, a cutter may be positioned at or near the distal end of a malleable shaft that may be shaped by the operator to a curvature suitable to access the desired anatomical location.

**[0021]** In certain variations, a medical device driven by a vacuum source may include a working end having an operable element. The operable element may be coupled to a mechanism, such that when the mechanism is driven by the vacuum source, movement of a drive piston actuates the operable element. The drive piston may be located in a chamber and may be moveable between a drive stroke and a return stroke. The device may include a valve configured to alternately seal and vent at least a portion of the chamber. A biasing component may be positioned against the drive piston, where evacuation of the chamber and movement of the biasing component when the chamber is

vented to ambient air causes the drive piston to cycle between a drive stroke and a return stroke.

**[0022]** In certain variations, a medical device driven by a vacuum source may include a handle having a linkage support element. A working end may be coupled to the handle, where the working end has an operable element and the operable element is coupled to a mechanism positioned in the handle. When the mechanism is driven by the vacuum source, movement of a drive shaft actuates the operable element. The drive shaft may be located in a chamber of the mechanism and moveable between a drive stroke and a return stroke. A shuttle body may be moveable between a forward and return positions, wherein movement between the forward and return positions alternates a fluid path between the chamber and vacuum source so that during application of vacuum from the vacuum source, movement of the shuttle body causes the drive shaft to cycle between the drive stroke and the return stroke. A linkage couples the drive shaft to the shuttle body to assist in switching the shuttle body between the forward and return positions and to prevent unstable flutter of the shuttle body between the forward and return positions. The linkage may be configured such that the linkage is supported by the linkage support element in a first position prior to use of the medical device and is unsupported by the linkage support element in a second position after use of the medical device.

**[0023]** In certain variations, a vacuum powered tissue cutting device may include an elongate shaft having a proximal end, a distal end and a lumen defined therein, where the distal end has an opening for receiving tissue. A cutter is positioned within the elongate shaft, wherein the cutter is configured to be actuated to cut tissue. A chamber is coupled to the proximal end of the elongate shaft, the chamber having a mechanism positioned therein and a linkage support element, wherein the mechanism is powered by suction created by a vacuum source such that the mechanism actuates which causes the cutter to actuate. The mechanism includes a piston and a valve, wherein the suction is applied to both sides of the piston in an alternating manner to cause the piston to actuate which causes the cutter to actuate, wherein the piston is coupled to the valve by a linkage that translates motion from the piston to the valve. The linkage may be configured such that the linkage is supported by the linkage support element in a first position prior to use of the medical device and is unsupported by the linkage support element in a second position after use of the medical device.

**[0024]** In certain variations, a vacuum powered tissue cutting device may include one or more of the following elements: an elongate shaft having a proximal end, a distal end

and one or more lumens defined therein, wherein the distal end has an opening for receiving tissue; a cutter positioned within the elongate shaft, wherein the cutter is configured to be actuated to cut tissue; and a chamber coupled to the proximal end of the elongate shaft, the chamber having a mechanism positioned therein, wherein the mechanism is powered by suction created by a vacuum source such that the mechanism actuates which causes the cutter to actuate. A malleable outer shaft may be positioned in a first lumen of the elongate shaft and an evacuation shaft may be positioned within the malleable outer shaft. The evacuation shaft may have a variable diameter to optimize a tissue resection rate or tissue evacuation rate.

[0025] In certain variations, a tissue cutting device may include one or more of the following: a cutting element; and a tissue filter mechanism having a filter lid and a filter body, wherein the filter body has at least one collection chamber for collecting filtered tissue and a bypass chamber configured to allow tissue and/or fluid to exit the tissue filter mechanism without collection of tissue in the bypass chamber.

[0026] In certain variations, a vacuum powered tissue cutting device may include one or more of the following: an elongate shaft having a proximal end, a distal end and one or more lumens defined therein, wherein the distal end has an opening for receiving tissue; a cutter positioned within the elongate shaft, wherein the cutter is configured to be actuated to cut tissue; and a chamber coupled to the proximal end of the elongate shaft, the chamber having a mechanism positioned therein, wherein the mechanism is powered by suction created by a vacuum source such that the mechanism actuates which causes the cutter to actuate; and a tissue filter mechanism coupled to the chamber, the filter mechanism having a filter lid and a filter body, wherein the filter body has at least one collection chamber for collecting filtered tissue and a bypass chamber configured to allow tissue and/or fluid to exit the tissue filter mechanism without collection of tissue in the bypass chamber.

#### BRIEF DESCRIPTION OF THE SEVERAL VIEWS OF THE DRAWINGS

[0027] Fig. 1A illustrates a side view of a variation of a cutting device.

[0028] Fig. 1B illustrates a side view of the cutting device of Fig. 1A with the right hand portion of the chamber hidden.

[0029] Fig. 1C illustrates a side view of the cutting device of Fig. 1B with the rigid sleeve and elongate shaft hidden to show the evacuation shaft.

[0030] Fig. 1D illustrates a side view of the cutting device of Fig. 1B with the manifold of the vacuum powered mechanism hidden.

[0031] Fig. 1E illustrates a side view of the cutting device of Fig. 1B with the collection chamber hidden to show a filter.

[0032] Fig. 1F illustrates a magnified view the elongate shaft of the cutting device of Fig. 1B having multiple lumens.

[0033] Fig. 1G illustrates a magnified view of the cutter of the cutting device of Fig. 1B.

[0034] Fig. 1H illustrates a vacuum source coupled to a variation of the cutting device.

[0035] Fig. 2A illustrates a side view of a variation of a vacuum powered mechanism.

[0036] Fig. 2B illustrates a cross sectional view of the vacuum powered mechanism of Fig. 2A.

[0037] Fig. 2C illustrates an opposite side view of the vacuum powered mechanism of Fig. 2A.

[0038] Fig. 2D illustrates a front view of the vacuum powered mechanism of Fig. 2A.

[0039] Fig. 2E illustrates a rear view of the vacuum powered mechanism of Fig.

[0040] Figs. 2F-2G illustrate side and prospective cross sectional views of the vacuum powered mechanism of Fig. 2A in a first position.

[0041] Figs. 2H-2I illustrate side and prospective cross sectional views of the vacuum powered mechanism of Fig. 2A in a second position.

[0042] Fig. 3A illustrates a cross sectional view of a variation of a double action vacuum powered mechanism having a bi-stable switch in a proximal position.

[0043] Fig. 3B illustrates a cross sectional view of the double action vacuum powered mechanism having a bi-stable switch of Fig. 3A in a distal position.

[0044] Fig. 4A illustrates the cross sectional view of a variation of a double action vacuum powered mechanism in a proximal position.

[0045] Fig. 4B illustrates a cross sectional view of the double action vacuum powered mechanism of Fig. 4A in a distal position.

[0046] Fig. 5A illustrates a cross sectional view of a variation of a single action vacuum powered mechanism using a spring return system in a proximal position.

[0047] Fig. 5B illustrates a cross sectional view of a single action vacuum powered mechanisms of Fig. 5A in a distal position.

- [0048] Fig. 6 illustrates a side view of a variation of an end effector.
- [0049] Fig. 7 illustrates a side view of a variation of an end effector.
- [0050] Fig. 8 illustrates a flow chart of a variation of a method for cutting and removing tissue using a vacuum powered cutting device.
- [0051] Fig. 9 illustrates a flow chart of a variation of a method for performing a polypectomy using a vacuum powered cutting device.
- [0052] Fig. 10 illustrates a flow chart of a variation of a method for performing a discectomy using a vacuum powered cutting device.
- [0053] Figs. 11A-11E illustrate a cross sectional side view of a variation of a vacuum powered mechanism utilizing a poppet valve.
- [0054] Figures 12A-12D illustrate various views of a variation of a vacuum powered cutting device utilizing the mechanism of figures 11A-11E.
- [0055] Figures 13A-13D illustrate various views of a variation of a vacuum powered cutting device including a mechanism having a deformable linkage.
- [0056] Figures 14A-14F illustrate various views of a variation of a shaft for use with a vacuum powered cutting device.
- [0057] Figures 15A-15F illustrate various views of a variation of a filter mechanism for integration in a microdebrider or tissue cutting or resection device.

#### DETAILED DESCRIPTION

[0058] Variations of the devices are best understood from the detailed description when read in conjunction with the accompanying drawings. It is emphasized that, according to common practice, the various features of the drawings may not be to-scale. On the contrary, the dimensions of the various features may be arbitrarily expanded or reduced for clarity. The drawings are taken for illustrative purposes only and are not intended to define or limit the scope of the claims to that which is shown.

[0059] Various medical devices, including various cutting devices and methods for cutting, resecting, incising or excising tissue are described herein. In certain variations a medical device may include a mechanism or motor driven or powered by a variety of different power sources, e.g., suction from a vacuum source, pneumatic, fluid pressure (e.g. hydraulic), compressed air, battery power or electrical power or gas power or any



combination thereof. The mechanism or motor may create a reciprocating or rotational motion output in any direction which may cause an operable element, such as a cutter on or in a cutting device, to actuate, e.g., reciprocate or rotate, to cut tissue. A cutting device may be utilized to cut, resect, incise or excise various types of tissue located in various regions of a patient's body. For example, the cutting device may be utilized to perform a polypectomy in a patient for removal of one or more polyps.

**[0060]** In certain variations, a cutting device powered by suction from a vacuum source (either external or internal) is provided. The cutting device may include an elongate shaft. The elongate shaft may have a proximal end, a distal end and one or more lumens positioned within or along the elongate shaft. The distal end of the elongate shaft may include an opening or window for receiving tissue. The device may include a cutter for cutting tissue. A cutter may be positioned within or on the elongate shaft. The cutter may be actuated, reciprocated, e.g., axially along the longitudinal axis of the elongate shaft, or rotated to cut tissue. A chamber may be coupled to the proximal end of the elongate shaft. Optionally, at least a portion of the elongate shaft may be coupled to the chamber such that at least a portion of the elongate shaft or a cannula (or the entire shaft or cannula) remains fixed or immovable in one or more direction relative to the chamber, e.g., while the cutter, on or in the elongate shaft or cannula, is being reciprocated or otherwise motivated or during actuation, reciprocation or rotation of the cutter.

**[0061]** A mechanism or motor may be positioned within the chamber. The mechanism may be powered by suction created by a vacuum source, which causes the mechanism to produce a reciprocating motion. In certain variations, the mechanism may be powered solely by suction created by the vacuum source, e.g., without the use of electricity or pressurized air or fluid to power the mechanism. Additional connections for electrical or pneumatic/hydraulic power may not be required. The mechanism may include a piston which is put into reciprocating or reciprocating linear motion by suction from the vacuum source. The reciprocating motion output produced by the mechanism causes the cutter (connected to the mechanism) to actuate, e.g., to reciprocate or to rotate. In certain variations, the cutter may be reciprocated back and forth in a linear motion, e.g., axially, or along the longitudinal axis of the elongate shaft. In other variations, linear reciprocating motion from the mechanism may be translated into rotational motion of the cutter. The cutting device may include a port or valve for connecting the vacuum source to the cutting device to provide suction to the cutting device.

[0062] The suction from a vacuum source may draw tissue into the opening in the elongate shaft. The cutter may be reciprocated or rotated past the opening in the elongate shaft, thereby cutting the tissue which is drawn into the opening of the elongate shaft. The cutting device may include an evacuation lumen for evacuating cut tissue using suction created by the vacuum source. In certain variations, the tissue may be otherwise removed without using evacuation to remove the tissue.

[0063] In certain variations, a lumen for delivering irrigant or fluid may be provided. For example, the elongate shaft may include a lumen for delivering irrigant to the distal end of an evacuation lumen in the elongate shaft or to an opening of the elongate shaft or to a cutter. The irrigant may flow constantly through the lumen, or it may flow through the lumen only when suction from the vacuum source is present to draw the irrigant through the irrigant lumen. The cutting device may include a reservoir filled with water or other irrigant positioned with the cutting device or the irrigant may be provided from an external supply. For example, a syringe filled with irrigant, e.g., water, may be connected to the cutting device or an elevated container or bag may supply irrigant to the cutting device or to the site of treatment. The irrigant may begin to flow through the cutting device when suction is present in a lumen within the elongate shaft, at an irrigant port, which may be located within the shaft lumen near the opening of the elongate shaft. The irrigant may be drawn to the distal end of an evacuation lumen in the elongate shaft or to the opening of the elongate shaft, where it lubricates tissue and a lumen within the shaft, e.g., a tissue evacuation lumen, to facilitate evacuation of the cut tissue.

[0064] The cutting device may include a handle, such that the cutting device may be handheld. For example, the chamber of the cutting device may be in the form of a handle. The handle may be positioned or set at an angle relative to the elongate shaft. This arrangement of the handle or chamber relative to the elongate shaft may provide a clear or substantially clear line of site above and/or to the sides of the elongate shaft. The angled arrangement may reduce interference with other medical devices or instruments that a user may utilize during a tissue cutting procedure, e.g. an endoscope and associated cables. This angled arrangement may also provide optimal user comfort. The handle may have an ergonomic design to provide comfort and ease of use. A curved or angled neck portion may extend from the chamber or handle, for receiving or holding the elongate shaft.

[0065] A tissue collection chamber may be provided. For example, a tissue collection chamber may be integrated in the chamber or handle of the cutting device or may be otherwise connected or attached to the cutting device. The tissue collection chamber may

be removable from the cutting device. The removable tissue collection chamber may allow tissue collected therein to be biopsied, studied or a diagnosis of pathology may be performed on the collected tissue. Removal of the tissue collection chamber and/or filter may result in the device being disabled, e.g., where the tissue collection chamber may not be reassembled to the device. This may prevent the device from being reused or used on more than one patient to minimize or prevent the associated risks of transmitting pathogens from one patient to another or infecting another patient. For example, the device may be disabled where the internal vacuum lines are sheered when the tissue collection chamber is removed from the handle. As a result, the tissue collection chamber cannot be reassembled to the device thereby rendering the device useless. The device may be fully or partially disposable.

[0066] In other variations, a tissue collection chamber may be reusable, where the tissue collection chamber may be removed, sterilized and then reassembled or reattached to the cutting device for continued use.

[0067] Various configurations of the elongate shaft are contemplated. In certain variations, at least a portion of the elongate shaft or the entire elongate shaft may be malleable or otherwise adjustable. For example, the distal end of the elongate shaft or the section of the elongate shaft where tissue cutting is performed may be malleable or flexible such that portion of the elongate shaft may be adjusted or manipulated by the user, e.g., hand adjustable. The malleable portion of the elongate shaft may be manipulated into a variety of shapes or curves such that the cutting device, e.g., the cutter or cutter opening, may access or be positioned in a variety of anatomical locations to cut and/or remove tissue. The malleable portion of the elongate shaft may be adjusted or manipulated before or during operation by the user into various positions or configurations, ranging from, straight to angled or curved. The shaft may be manually, automatically or robotically adjusted. The shaft may be adjusted without the need for additional tools or attachments to change or affect the shape or position of the shaft, such that the positioning for cutting and cutting may be performed using a single device. In other variations, a tool or attachment may optionally be utilized to adjust or manipulate an elongate shaft for cutting.

[0068] A cutter may have various shapes and configuration, e.g., the cutter may be in the form of a cutting blade or pipe or tube positioned within the elongate shaft. A cutter may be positioned in the cutting device such that the cutter can reciprocate past an opening or cutting window in the elongate shaft. In certain variations, the cutter may be positioned

within or on the elongate shaft such that the cutting blade is not exposed on an outside of the opening or window in the elongate shaft or beyond the distal tip of the elongate shaft. This arrangement may provide safety to patients and minimize or prevent the risk of inadvertently cutting or puncturing tissue in a patient during the tissue cutting procedure or during advancement of the cutting device to the target site in a patient for treatment. In certain variations, the anvil may protect a cutter such that it is not exposed, thereby providing safety to patients.

**[0069]** A sufficient vacuum source for operating or powering any of the cutting devices described herein may be the vacuum source provided in most standard operating rooms, physician's offices, clinics or outpatient surgery centers. For example, many physicians' offices have vacuum pumps capable of generating vacuum in the ranges of 10 to 25 inches of mercury (in HG), e.g., about 22 inches of mercury (in Hg) and/or at about 28 to about 40 liters per minute (LPM) flow rate. The various cutting devices described herein may utilize vacuum sources or vacuum pumps operating in the above performance ranges to effectively operate and cut tissue without additional power inputs or supply requirements needed. For example, suction provided by such vacuum sources may move, actuate, reciprocate or otherwise operate the mechanism of a cutting device and/or the cutter at a speed or rate ranging from about 250 to about 2500 cycles/min or about 500 to 1200 cycles per minute or less than about 1200 cycles per minute. These rates are slower than the rates that would be provided by a typical electrically powered motor, yet provide the control and power to effectively and safely operate and reciprocate the cutter of the cutting devices described herein to cut, resect, and/or excise tissue in various regions in a patient, e.g., to cut and remove polyps positioned in the nasal or sinus cavity of a patient in a safe, controlled and effective manner.

**[0070]** In certain variations, a cutting device may be connected solely to a vacuum source, and optionally, to an irrigant source. The vacuum source may be connected to the cutting device such that suction supplied by the vacuum source drives or powers the mechanism of the cutting device, draws tissue into the opening in the elongate shaft or otherwise into the path of a cutter, draws irrigant from a reservoir or other source through the cutting device or through a lumen in or on the cutting device, or to the cutting device and/or evacuates cut tissue for removal from a patient.

**[0071]** Various vacuum powered mechanism for use in the various cutting devices described herein, to drive or actuate a cutter, are also described herein. In certain variations, a vacuum powered or vacuum driven mechanism may include one or more

pistons, wherein suction is applied to both sides of the piston in an alternating manner to cause the piston to reciprocate. The piston is coupled or connected (directly or indirectly) to the cutter, thereby causing the cutter to reciprocate. In another variation, suction may be applied to one side of the piston and a spring force in a vacuum powered mechanism may be applied to the other side of the piston, to cause the piston to reciprocate. The reciprocating piston causes the cutter to reciprocate.

[0072] In certain variations, a hand-held, fully disposable powered medical device capable of resecting tissue in the human body is provided. The device is powered by an internal mechanism that is powered by suction from an external vacuum source. The mechanism produces reciprocating motion that may be used to move a cutter back-and-forth past an opening in a shaft. A portion of the suction from the external vacuum source is routed through the shaft and draws tissue into the window where it is excised by the cutter. The tissue is then evacuated through the shaft and into a tissue collection chamber on the handle of the device. The suction in the shaft also draws irrigant into the lumen of the shaft, where it lubricates the tissue and shaft lumen to facilitate evacuation of the tissue.

[0073] In certain variations, the cutting devices or mechanisms described herein may be powered by a vacuum source where the devices have an efficient use of supplied vacuum suction to the device, e.g., with none of the supplied suction going unused. In certain variations, a cutting device may be powered by constant delivery of vacuum or suction. In certain variations, a cutting device may be manufactured of all or substantially all mechanical components reducing costs for manufacturing.

[0074] In certain variations, a cutter may be positioned at or near the distal end of a flexible shaft that has a preformed or predetermined curvature. The shaft may be adapted for insertion into a cannula where the distal end of the shaft may advance from the cannula toward a target site and where the shaft allows its predetermined curvature to position the distal end of the shaft near the target site.

[0075] Exemplary Cutting Devices

[0076] Figure 1A shows one variation of a vacuum powered cutting device. Referring to Figures 1B-1E, the cutting device 10 includes an elongate shaft 12. The elongate shaft 12 may include a rigid sleeve 14 that provides rigidity to the elongate shaft. The elongate shaft may include a window or cutting window or opening 16 positioned at or near a distal

end of the elongate shaft. An evacuation shaft 17 may be positioned within the elongate shaft 12. A cutter 18 may be positioned within the elongate shaft 12 such that it may be reciprocated past the opening 16. In this particular variation, the cutter 18 is formed at the distal end of the evacuation shaft 17, but other types of cutters are contemplated, e.g., the cutter 18 may extend from a wire or blade positioned in the elongate shaft 12.

[0077] One or more lumens may be positioned within the elongate shaft 12 (See Fig. 1F). Elongate shaft 12 may include an irrigant lumen. An irrigant line (not shown) may connect to the proximal end 13 of the elongate shaft 12, to supply irrigant from an internal or external reservoir or irrigant source, through an irrigant lumen in the elongate shaft 12, to the distal end of an evacuation lumen in the elongate shaft or to the opening 16 of the elongate shaft 12. For example, the irrigant may be drawn to the opening 16 of the elongate shaft 12, where it lubricates tissue and the evacuation lumen, to facilitate evacuation of the cut tissue. Optionally, the elongate shaft 12 may include a malleable portion, for example at its distal end, which can be manipulated or adjusted to provide various shapes and configurations to the elongate shaft 12 to position a cutter in various regions of the body. Optionally, one or more wires 15 may be positioned in the elongate shaft 12, which may serve to hold the malleable portion of the shaft in a desired position. A rigid sleeve 14 may be placed over other portions of the elongate shaft 12 to provide rigidity.

[0078] The elongate shaft 12 may extend from a chamber 20. The chamber 20 may provide a handle or grip for a user. The chamber 20 may include a tissue collection chamber 22. The evacuation shaft 17 may extend into the chamber 20, such that one or more lumens of the evacuation shaft 17 empties into the tissue collection chamber 22 either directly or indirectly, e.g., via another tube or pipe (not shown), connecting the evacuation shaft 12 to a first vacuum chamber port 21. The tissue collection chamber 22 may include a filter 25 for filtering tissue collected therein. The tissue collection chamber 22 may be integrated into the chamber 20 such that removal of the tissue collection chamber 22 disables the cutting device 10. In certain variations, the elongate shaft 12 may be coupled or connected to the chamber 20 such that the elongate shaft 12 remains fixed relative to the chamber 20. For example, the elongate shaft 12 may be fixed such that it is not motivated or reciprocated by the mechanism 30 or motor described below. In certain variations, the elongate shaft 12 may be coupled or connected to the chamber 20 such that at least a portion of the elongate shaft 12 or the entire shaft remains fixed or is configured to remain stationary in one or more directions relative to the chamber 20, e.g.,

during actuation of the cutter. At least a portion of the elongate shaft 12 may be coupled or connected to the chamber such that at least a portion of the elongate shaft is not motivated or reciprocated by the mechanism 30 or motor described below in one or more directions relative to the chamber, e.g., in axial direction along a longitudinal axis of the chamber or shaft, and at least a portion of the elongate shaft may be moveable or malleable as described herein. Optionally, at least a portion of the shaft or the entire shaft may be or remain movable or not fixed or stationary in one or more directions relative to the chamber.

[0079] A vacuum powered mechanism 30 is positioned within the chamber 20. Figures 2A-2I show various views of the vacuum powered mechanism 30. The mechanism 30 includes a shuttle body or shuttle piston 32 and a drive shaft or drive piston 34. The pistons may be arranged in various configuration, e.g., in parallel to one another. A bi-stable switch 36 may be connected to the shuttle piston 32 and the drive piston 34. The bi-stable switch 36 having a switch spring 37 may be connected to the drive piston 34 and the shuttle piston 32 either directly or via a piston clamp 35 connected to the switch spring 37 or bi-stable switch 36. Actuation of the bi-stable switch 36 by the drive piston 34, which is motivated or reciprocated by suction created by the vacuum source, may reverse or move the shuttle piston 32 in either the proximal or distal directions (i.e., toward the distal end of the cutting device or toward the proximal end of the cutting device.) When the shuttle piston 32 moves from one end of its' travel extremity to the opposite end of its' travel extremity, the evacuated side of a drive piston chamber 42 is vented to allow atmospheric air to flow into the drive piston chamber 42 while the opposite side of the drive piston chamber 42 is shut off from atmospheric air and evacuated. As a result, the drive piston 34 is motivated to move in the opposite direction until the bi-stable switch 36 is actuated and the shuttle piston 32 reverses. The shuttle piston 32 and the drive piston 34 are positioned in a manifold 38. The manifold 38 includes a drive piston chamber 44 and a shuttle piston chamber 42. The bi-stable switch 36 may ensure a reliable transition of the shuttle piston 32 or valve on the shuttle piston past or completely past a shuttle chamber vacuum supply port 47 to prevent unstable flutter of the shuttle piston 32 and possible mechanism 30 or motor stall.

[0080] As shown in the various cross sectional views of Figure 2B and Figures 2F-2I, at least a portion of the drive piston 34 is positioned in the drive piston chamber 44 and at least a portion of the shuttle piston 32 is positioned in shuttle piston chamber 42. The

drive piston chamber 44 and the shuttle piston chamber 42 are in fluid communication with each other via first and second vacuum slots 45 and 46.

[0081] A shuttle chamber vacuum supply port 47 is provided to connect a vacuum source, via a tube or line (not shown), to the mechanism 30 to provide suction to the mechanism 30. Figure 1H shows a vacuum source coupled to a variation of the cutting device 10. The tube or line may be connected to a second vacuum chamber port 28 (shown in Figures 1B-1D) and/or the shuttle chamber vacuum supply port 47. The shuttle chamber vacuum supply port 47 provides entry into the shuttle piston chamber 42, such that the vacuum source can be in fluid communication with the shuttle piston chamber 42 and evacuate the shuttle piston chamber 42 and/or the drive piston chamber 44, to power and motivate the drive piston 34 and/or the shuttle piston 32, as described in further detail herein. Details of a vacuum powered mechanism are also provided below with reference to Figures 3A-3B.

[0082] The mechanism 30 may be activated and the drive piston 34 reciprocated by suction from the vacuum source as soon as the vacuum source is connected to the cutting device 10 and the vacuum source is activated. Referring back to Figs. 1A-1E, the cutting device 10 may also include a trigger 26 positioned on the chamber 20 in a location such that the trigger 26 can be conveniently or ergonomically actuated by a user's finger as the user holds the cutting device 10. When the trigger 26 is in the "on" position, the trigger 26 is disengaged from the shuttle piston 32, allowing the shuttle piston 32 to reciprocate due to motivation of the bi-stable switch 36 which is in turn motivated by the movement of the drive piston 34. When the trigger 26 is actuated into an "off" position, the trigger 26 may interact with or engage the shuttle piston 32, which causes the shuttle piston 32 and drive piston 34 to stall or stop such that the cutter 18 is stopped in a position proximal to the opening 16 thereby leaving the opening 16 open. This allows the device 10 to be used for suction or evacuation through opening 16, even when the mechanism 30 and cutter 18 are not activated, as the vacuum source may remain activated and connected to the cutting device 10, supplying suction through a lumen of the evacuation shaft 17. In certain variations, suction may not be supplied through the lumen of the evacuation shaft during cutting.

[0083] The vacuum source may be connected to the cutting device 10 at the external vacuum port 29. The external vacuum port 29 is in fluid communication with the tissue collection chamber 22 and the first vacuum chamber port 21, supplying suction to the lumen of the evacuation shaft. The external vacuum port 29 is in fluid communication



with the second vacuum chamber port 28, supplying suction through the shuttle chamber vacuum supply port 47 to the shuttle piston chamber 42 and the drive piston chamber 44, to motivate, reciprocate and/or power drive piston 34, which motivates or reciprocates the bi-stable switch 36 and cutter 18, which is connected to the vacuum powered mechanism 30 either directly or indirectly.

[0084] In use, the elongate shaft 12 of the cutting device 10 may be inserted into the desired location or area in a patient. The vacuum source is connected to the cutting device 10, supplying suction to the mechanism 30, causing the drive piston 34 to reciprocate. The drive piston 34 causes one side of the bi-stable switch 36 to move either proximally or distally which increases the tension on the extension spring 37. The increased tension on the extension spring 37 causes the adjacent side of the bi-stable switch 36 and the shuttle piston to move proximally or distally to decrease the length of the extension spring 37. When the seal on the shuttle piston or shuttle piston 32 moves past the suction port 47, the vacuum or suction in the shuttle chamber 42 reverses to the opposite side of the drive piston 34 while atmospheric air is allowed to flow into the side of the shuttle chamber 42 that is not evacuated, thereby motivating the drive piston 34 to move toward the evacuated side. (As shown for example in Fig. 2B). The evacuation shaft 17 is connected to the drive piston 34. The evacuation shaft 17 may be connected directly to the drive piston 34 or the evacuation shaft 17 may be connected to sleeves, tubes or other shafts that are connected to the drive piston 34. For example, the piston clamp 35 may connect the evacuation shaft 17 to the drive piston 34.

[0085] As stated supra, the cutter 18 is formed at the distal tip of the evacuation shaft 17. Once the vacuum source is connected to the cutting device 10 and the trigger 26 is positioned in the "on" position such that it is disengaged from the shuttle piston 32, suction applied to the mechanism 30 causes the drive piston 34 (and consequently the shuttle piston 32 as described above) to reciprocate, which causes the evacuation shaft 17 and the cutter 18 to reciprocate, driving the cutter 18 back and forth, e.g., in a linear or axial motion along the longitudinal axis of the elongate shaft, past the opening 16 in the elongate shaft 12. A close up of a variation of a cutting window is shown in Fig. 1G. At the same time, suction may be supplied from the vacuum source through a lumen of the evacuation shaft 17, to draw tissue into the opening 16, where the tissue is then cut by the reciprocating cutter 18. Optionally, the suction in the evacuation lumen may also evacuate the cut tissue and deliver it to the tissue collection chamber 22.

[0086] While the reciprocating motion of the drive piston 34 of the mechanism 30 is translated to the cutter 18 via the evacuation shaft 17 in the variation described above, other components for translating such reciprocating motion are also contemplated. For example a cutter may extend from a wire or blade or any other extension or member which is connected to the mechanism 30, e.g., via the drive piston 34 or piston claim 35. In certain variations, the cutter 18 may be directly or indirectly connected to the mechanism 30 or the drive piston 34 or the shuttle piston 32 or the bi-stable switch 36.

[0087] In certain variations, a loop or extension may be provided in the evacuation shaft 17 or in a tube or pipe connecting the evacuation shaft 17 to the first vacuum chamber port 21, providing extra length that may move or change shape such that at least a portion of the evacuation shaft 17 or tube or pipe that is connected to the first vacuum chamber port 21 does not move or reciprocate or become dislodged when the evacuation shaft 17 is being reciprocated or motivated by the mechanism 30.

[0088] In certain variations, a method of cutting and removing tissue from a subject may include advancing a cutting device at, next to, in or near a target tissue in the subject. The cutting device may include an elongate shaft and a cutter positioned within or on the elongate shaft. The elongate shaft may be advanced into the subject to access the target tissue and to position the cutter at, next to, in or near the target tissue to cut and/or remove the tissue. The cutting device includes a mechanism or motor which is powered or driven by suction created by a vacuum source. The suction from the vacuum source powers the mechanism causing it to produce a reciprocating or rotating motion which causes the cutter to reciprocate or rotate to cut tissue. The tissue may optionally be evacuated using suction created by the vacuum source. The cut tissue may optionally be gathered or collected with the cutting device. In certain variations, suction or vacuum may be turned off or not supplied to the opening and the tissue may be otherwise removed. In certain variations, the suction from the vacuum source may draw tissue into an opening on the elongate shaft. The cutter may be reciprocated or rotated past the opening to cut the tissue drawn into the opening on the elongate shaft. In certain variations suction from the vacuum source may draw an irrigant to the distal end of an evacuation lumen in the elongate shaft or to the opening of the elongate shaft, where it lubricates tissue and/or the evacuation lumen, to facilitate evacuation of the cut tissue. In certain variations, the cutting device may include a chamber in which the mechanism is positioned. The elongate shaft may be attached to the chamber such that at least a portion of the shaft or the entire shaft remains in a fixed position or is configured to remain stationary in one or

more directions relative to the chamber, e.g., while the mechanism is producing a reciprocating motion and/or reciprocating or rotating a cutter, cutter shaft or evacuation shaft positioned within the elongate shaft.

**[0089]** In certain variations, a method of cutting, resecting or excising tissue in a patient may include attaching the cutting device to a vacuum source (internal or external) and optionally to a source of irrigant. The vacuum source supplies suction that may power or motivate the mechanism or motor of the cutting device, draw tissue into the path of a cutter or cutting blade, draw irrigant from an irrigant source to the site of cutting or excision or near the cutter, and/or evacuate cut tissue from the patient.

**[0090]** In certain variations, a method for performing a polypectomy in a subject may include advancing a cutting device at, to, next to, in or near a target polyp. Polyps may be located in various regions of a patient. For example, nasal or sinus polyps may be cut and/or removed by advancing the cutting device into the nasal cavity and positioning a cutter at, next to, in or near the polyp. The cutting device may include an elongate shaft and a cutter positioned within or on the elongate shaft. The elongate shaft of the cutting device may be advanced into the nasal or sinus cavity to access the polyp and position the cutter near the polyp. The cutting device includes a mechanism or motor which is powered by suction created by a vacuum source. The suction from the vacuum source powers the mechanism causing it to produce a reciprocating or rotating motion which causes the cutter to reciprocate or rotate to cut tissue. The tissue may optionally be evacuated using suction created by the vacuum source. The cut tissue may optionally be gathered or collected with the cutting device. In certain variations, suction or vacuum may be turned off or not supplied to the opening and the tissue may be otherwise removed. In certain variations, the suction from the vacuum source may draw tissue into an opening on the elongate shaft. The cutter may be reciprocated past the opening to cut the polyp tissue drawn into the opening on the elongate shaft. In certain variations, the mechanism may be powered solely by suction from a vacuum source, without requiring the use of compressed or pressurized air or electric power to supply power.

**[0091]** In certain variations, a method for performing a discectomy in a subject may include advancing a cutting device at, to, next to, in or near a disc in a spine. For example, a disc annulus or nucleus may be cut by advancing the cutting device into or next to the disc and positioning a cutter at, next to, in or near the disc. The cutting device may include an elongate shaft and a cutter positioned within or on the elongate shaft. The elongate shaft of the cutting device may be advanced into or next to the disc to position the

cutter. The cutting device includes a mechanism or motor which is powered by suction created by a vacuum source. The suction from the vacuum source powers the mechanism causing it to produce a reciprocating or rotating motion which causes the cutter to reciprocate or rotate to cut tissue. The tissue may optionally be evacuated using suction created by the vacuum source. The cut tissue may optionally be gathered or collected with the cutting device. In certain variations, suction or vacuum may be turned off or not supplied to the opening and the tissue may be otherwise removed. In certain variations, the suction from the vacuum source may draw tissue into an opening on the elongate shaft. The cutter may be reciprocated past the opening to cut the disc tissue drawn into the opening on the elongate shaft. In certain variations, the mechanism may be powered solely by suction from a vacuum source, without requiring the use of compressed or pressurized air or electric power to supply power.

[0092] In certain variations, a user may cut tissue by positioning a cutting window on an elongate shaft against the tissue to be resected and actuate a switch or trigger to allow the mechanism to reciprocate. This causes a cutting blade to move back-and-forth past the cutting window. As tissue is drawn into the cutting window by suction, the blade shaves the portion of tissue that is in the path of the cutting blade. The tissue is then evacuated through the lumen of the shaft that is connected to the blade and is deposited in a tissue collection chamber.

[0093] The cutting devices described herein may be utilizing for a variety of procedures as described supra. The cutting device may be advanced or inserted into or through existing orifices, cavities or passages, e.g., a nasal cavity, airway, respiratory passage, reproductive pathways, intestinal pathways or other pathways. The cutting devices may be advanced or inserted into a patient percutaneously, intraluminally or in any minimally invasive manner to perform a procedure in or on a subject. Optionally, a cutting device may be utilized through a surgical incision or site.

[0094] The various cutting devices described herein, e.g., a handheld and/or portable cutting device, allow for cutting and/or removal of tissue, e.g., a nasal polyp, by providing a low cost, disposable device that allows the tissue cutting procedure to take place in a manner that is safe, quick, and inexpensive. The cutting device does not require significant setup time, or the inconvenience and expense associated with capital equipment. In-office tissue removal using a cutting device may be performed using local anesthetic as compared to general anesthetic which is used in ambulatory surgery centers. For example, a cutting device may be utilized to perform nasal and sinus polyp removal in

a doctor's office setting. While the cutting devices described herein may be used to perform a polypectomy, they can also be used for tissue resection procedures in other locations of the body, e.g., including for ear, nose, and throat surgery, gynecological surgery, spinal surgery, general surgery and ophthalmic surgery.

[0095] A cutting device that uses a vacuum source, e.g., an external vacuum source, to power an actuating or reciprocating mechanism or motor that is connected to a cutter, thereby translating the reciprocating motion to the cutter to cause the cutter to reciprocate provides a number of advantages and efficiencies. The cutting device does not require an investment in capital equipment, such as electric powered consoles, thus providing a user with a substantial cost savings. Capital equipment requires valuable storage space when not in use as well as service and maintenance in the facilities where it is used. The cutting device also allows a manufacturer to make continuous improvements without being constrained by installed capital equipment.

[0096] The cutting devices described herein may be manufactured using low cost components and assembly techniques, making the cost of the device much lower than a cutting device which utilizes an electric motor. The elongate shaft may be constructed from a variety of materials. For example, a combination of metal and plastic components that are not susceptible to heat buildup resulting from friction between moving components may be utilized.

[0097] Using a vacuum source as the power source to provide both tissue evacuation and mechanical motion to cut tissue eliminates or reduces the number of additional or separate connections, wires or tubes that would otherwise be required to provide electrical or other pneumatic power, such as pressurized or compressed air, and evacuation. A standalone console to transfer the electrical or other pneumatic power may not be required to operate the cutting device.

[0098] In certain variations, a single tube connects the vacuum source to the cutting device to serve the functions of tissue cutting, evacuation, and to power the mechanism which actuates the reciprocating cutter. A single tube simplifies connections required for device operation and reduces the number of tubes attached to the device thereby reducing the "clutter" and unwieldiness caused by multiple tubes and wire connections extending from a device.

[0099] In certain variations, a splitting connection within the handle may be provided which connects the vacuum to both a tissue evacuation tube and the vacuum powered mechanism. The splitting connection may come in multiple forms such as multiple

connections to the tissue collection chamber where a single connection to a source of vacuum creates a vacuum within a Filter Chamber. Another form of a splitting connection may be a “Y” or “T” shaped junction that joins two fluid paths into a single path. As a result of sharing the vacuum source between the mechanism and the evacuation tube and cutting window or opening, the vacuum perform several functions within the device: powers the mechanism which causes the cutter to reciprocate, draws tissue into an opening or cutting window such that it may be excised, evacuates the excised tissue through the tissue evacuation shaft to a filter or tissue collection chamber.

**[0100]** Where an external vacuum source is connected to the device to provide suction to facilitate tissue cutting and evacuation, an additional power source such as electricity, compressed air, or mechanical input by the operator may not be required.

**[0101]** Using vacuum power to actuate the cutter reduces operator fatigue compared to a system requiring the operator to manually actuate the reciprocating mechanism. The rate at which the cutter actuates relative to manual actuation may be significantly increased, thereby reducing the time required to complete a tissue resection or excision procedure. Also, the control for the rate of actuation of the mechanism or motor may be moved from a “primary” position, such as a trigger or button, to a “secondary” position, e.g., on the device handle. As a result, the “primary control” may be utilized to control other parameters, e.g., the rate at which the cutter actuates, the radius of curvature of the elongate shaft, or to control an electrocautery system that may be included in or on the device. A knob, trigger, roller clamp, or other control interfaces may be used to control the rate at which the vacuum driven mechanism or motor actuates or reciprocates. These options allow the device to be designed in a variety of configurations to suit various surgical specialties or personal preferences.

**[0102]** The cutting devices described herein may have a relatively low mass, providing ease of use and comfort during short or long procedures. The cutting devices may be easily sterilized using commonly used sterilization techniques such as electron beam radiation, gamma radiation, or Ethylene Oxide gas.

**[0103]** In certain variations, a pneumatic logic sequence that maintains high vacuum throughout the mechanism, motor or engine cycle by never venting the vacuum source to the atmosphere may be provided. As a result, the vacuum suction or pressure that facilitates cutting and evacuation does not decrease while the mechanism or motor reciprocates.

[0104] In certain variations, the cutting device may include cautery, e.g., an electrocautery system or wires heated via monopolar or bipolar radiofrequency, or by resistive heating. The cautery may be located at or near the distal extremity of the device to cauterize tissue to control bleeding at the site where tissue has been cut or excised. Having a cautery obviates the need to remove the device from an operative site and replace it with a separate electrocautery device, thereby improving speed and ease-of-use for the operator while reducing blood loss for the patient. The electrocautery system may be powered by wires that run the length of the elongate shaft through an internal lumen within the elongate shaft. The wires may be connected to a power console or optionally the power source may be located in the handle or chamber of the cutting device.

[0105] In certain variations, a resistive heating electrocautery system may be provided on the distal tip of an elongate shaft. The power source for the electrocautery system may be located in the handle of the cutting device and may be connected to the distal tip of the shaft by wires that run the length of the shaft. The power source may include one or more batteries that provide electrical energy to the distal end of the device. The electrical energy may be converted to heat energy when passed through a heating element such as a tungsten wire.

[0106] As described supra, in certain variations, a cutting device may include a malleable elongate shaft or at least a partially malleable elongate shaft that may be hand adjustable. A flexible or malleable shaft provides access to multiple anatomical locations using a single device, thereby improving cost efficiency and convenience for the operator. One or more annealed wires may be positioned in an elongate shaft or flexible shaft to allow the shaft to be manually shaped by the user intra-operatively. Alternatively, malleable tubing may be used to construct the elongate shaft to allow manual shaping of the shaft. Additionally, when the distal end of the elongate shaft is curved toward the cutting window, visibility of the cutting window location is improved.

[0107] In certain variations, the elongate shaft may be flexible and a semi-rigid or rigid outer cannula or sheath may be provided on the shaft to change the radius of curvature on the shaft in a range from substantially straight to curved, in an arc of about 180 degrees. The cannula allows the operator to optimize the curvature of the shaft based on the patient anatomy. The operator may also increase or decrease the force between the elongate shaft or cutter and the target tissue being cut by extending or retracting the cannula to increase or decrease the natural radius of curvature of the elongate shaft.

[0108] In certain variations, a semi-rigid or rigid outer sheath or cannula positioned over a flexible curved elongate shaft may be used to change the radius of curvature of the curved shaft. The radius of curvature may increase when the straight and rigid sheath is extended over the curved portion of the shaft, whereas the radius of curvature returns to its precurved or predetermined shape when retracted from the curved portion of the shaft.

[0109] The radius of curvature of a flexible curved elongate shaft may be altered in-vivo by utilizing or advancing or retracting a cannula over the elongate shaft. This allows the operator to change the radius of curvature of the elongate shaft in situ to gain access to a variety of anatomical locations without removing the device or elongate shaft from the operative site to change the radius of curvature.

[0110] In certain variations, the distal tip of the elongate shaft may be rounded and less likely to perforate sensitive structures or other tissue during advancement to a target tissue or while cutting is being performed. This reduces susceptibility to inadvertent contact with tissues that may result in unintended injury to the patient.

[0111] Reciprocating a cutter in a back-and-forth motion may shave and cut tissue by scissoring it rather than grabbing and ripping tissue as may be the case with certain rotary cutters or rotary mechanisms or motors. Back-and-forth cutting action may shave tissue with less movement of the tissue, which reduces the tension on the tissue and consequent trauma to the tissue thereby reducing the likelihood of bleeding. The excised tissue may then be evacuated through an evacuation shaft and into a tissue collection chamber.

[0112] An elongate shaft that includes a cutter shaft or an evacuation shaft with a cutter at its distal end, which may be reciprocated in a back and forth motion along the longitudinal axis of the elongate shaft, may be positioned in line or at an angle relative to the vacuum driven mechanism or motor and the handle or chamber in which the mechanism or motor is positioned. Positioning at an angle allows the device handle to be positioned away from the control surfaces, light cord, and any power cables for an endoscope and/or camera that may also be used during the tissue cutting procedure. The operator's ease-of-use is improved because the endoscope and the cutting device are not interfering with one another.

[0113] A cutting device having a handle or hand piece that may be positioned in line with an elongate shaft or at an angle to the longitudinal axis of the elongate shaft may provide improved ergonomic features for the operator. For example, when the operator is using a second device, (e.g., an endoscope as described supra) through the same orifice or port that the elongate shaft of the cutting device has entered, the two devices may interfere



with one another. However, by positioning the handle or hand piece at an angle to the longitudinal axis of the shaft, the top and sides of the cutting device around the shaft and the connection between the handle and the shaft are at a very low profile. Thus, the likelihood of interference is reduced. In certain variations, the elongate shaft may be actuatable, such that the elongate shaft may be moved between a position in line with a handle or at an angle to a handle.

**[0114]** The back and forth reciprocating motion of a cutter shaft or an evacuation shaft with a cutter blade at its distal end may be translated along a nonlinear path. Therefore, it is possible to position the vacuum driven mechanism or motor at an angle relative to elongate shaft of the device. Furthermore, the back and forth reciprocating motion of the cutter shaft or an evacuation shaft allows the elongate shaft of the cutting device to be bent at the distal portion of the shaft (e.g., where the shaft is malleable) to allow it to be shaped to access a variety of locations in the anatomy.

**[0115]** In certain variations, separate conduits may be provided between the mechanism and evacuation lumen such that vacuum for evacuating tissue is not interrupted by the mechanism function.

**[0116]** An anvil component may be located at the distal end of the elongate shaft. An extension (e.g., a "tail") of the anvil may be provided proximal to the cutting window. The extension may improve flexibility of the shaft allowing the shaft to be malleable closer to the distal end of the shaft. The anvil and/or extension may maintain or provide a guide for the evacuation shaft or the cutter shaft as it translates or reciprocates axially. In the absence of an extension, a longer anvil component that may be rigid over its entire length or a portion of its length may be provided.

**[0117]** In certain variations, a cutting opening or window may be positioned on the side of the elongate shaft. The side positioning allows the operator to maintain visual contact or visualization on the position of the opening or window and tissue that comes into contact with the opening or window. This visual contact reduces the likelihood of unintentionally causing injury to tissue.

**[0118]** A cutting window may be shaped to prevent the cutter from exiting the lumen of the elongate shaft or the anvil component, through the cutting window. The cutting window in combination with the cutter may provide a tissue scissoring cutting action, as compared to a guillotine cutting action on a straight sided cutting window.

**[0119]** In certain variations, the distal portion of an elongate shaft may be plastic, an indwelling anvil component may be metal, a cutter may be metal and the evacuation tube

may be plastic. This arrangement may reduce the likelihood of heat build up from friction between moving and/or stationary components of the cutting device. This arrangement may create a scissoring cutting action, and/or allow the distal end of the elongate shaft to be flexible and malleable. Additionally, the use of plastic components reduces or eliminates the possibility that electrical energy may be unintentionally transmitted through the shaft thereby injuring the patient.

[0120] Optionally, the elongate shaft may be rotatable about the axis of the shaft relative to the device handle or chamber, which allows the operator to rotate the shaft without rotating the device handle.

[0121] In certain variations, one or more lumens 51, e.g., nonconcentric lumens may be positioned in the elongate shaft (As shown in Fig. 1F). Nonconcentric lumens may provide advantages compared to single lumen shafts and shafts having concentric lumens. For example, one or more of the lumens may be used for the following purposes: to provide a fluid conduit for irrigant; to hold or contain one or more malleable wire(s) to maintain the shaft curvature when shaped by the operator; to contain the evacuation shaft or cutter shaft and evacuation lumen; and/or to transmit fluid to treat bleeding.

[0122] In certain variations, an evacuation lumen may be non contiguous around its circumference down a portion or the entire length of the evacuation shaft to improve flexibility while reducing the likelihood of kinking the evacuation lumen.

[0123] A small gap or a sealing O-ring between the evacuation shaft and the inside of the main lumen of the elongate shaft, may reduce the likelihood of leakage of suction through the proximal end of the elongate shaft, which would reduce the suction present at the window.

[0124] Optionally, a ring of material may be provided between the outside diameter of a noncontiguous evacuation lumen and the inside diameter of a multi-lumen evacuation shaft or tubing that seals the air gap between the two structures and thereby reduces leakage of air flow in the distal direction from the device handle to the opening in the evacuation shaft or lumen, located proximal to the cutting window or opening.

[0125] Optionally, various fluids may be applied or delivered to the distal end of the elongate shaft where the cutter and window are positioned. A fluid may be emitted, via a lumen in the elongate shaft, from the distal end of an elongate shaft at a temperature that is low enough such that the fluid can be used as a bleeding therapy. A collagen foam may be emitted from the distal end of the elongate shaft as a bleeding therapy. These are inexpensive, quick, and easy ways to apply a bleeding therapy or anticoagulant to a

bleeding site where tissue is being cut. Anti-coagulant substances emitted from the distal end of the elongate shaft as a bleeding therapy may be applied directly and conveniently to the tissue, e.g., without exchanging or removing the cutting device to replace it with a separate device intended for applying anticoagulation therapy.

[0126] In certain variations, separate fluid conduit paths to the vacuum source may be provided to allow the vacuum powered mechanism and cutter to be operated independently from the tissue evacuation. The independent fluid paths and operation capability of the vacuum powered mechanism and evacuation may allow the opening in the distal end of the elongate shaft of the cutting device to operate as a suction port to evacuate tissue and blood even when the vacuum powered mechanism is not in operation or is stalled or halted, e.g., when the trigger is actuated to engage and hold the shuttle piston to prevent its reciprocation.

[0127] Optionally, a single fluid conduit path between a cutting window and the vacuum source that includes an evacuation shaft and vacuum mechanism may be utilized to reduce the air flow requirements of the device by using air flow created by the vacuum to power both the vacuum mechanism and the evacuation of tissue.

[0128] Set forth below are additional features or functions that may be utilized or included with various cutting devices described herein:

[0129] A clear tissue collection chamber may be utilized to allow the operator to intraoperatively visualize resected tissue in real time. Additionally, the operator and patient are able to see whether the device has been previously used by inspecting the tissue collection chamber.

[0130] A dual chamber tissue collection system may be provided to separate tissue resected from different locations in the event it is desired to biopsy the tissue from two different locations in the body

[0131] A bi-stable switch fabricated from plastic, metal or other material and an elastic spring may be utilized in a mechanism to ensure reliable transition of a Shuttle piston past a vacuum supply port to prevent unstable flutter of the Shuttle piston and consequent mechanism or motor stall. Optionally, a bi-stable switch fabricated using sheet metal with two legs that are connected at one end but separated at the opposite end in their natural state may be provided. The separate sheet metal legs are then riveted or otherwise connected to create a bowed sheet metal component that is stressed and bi-stable. Optionally, the separated end may be folded and joined to result in a three dimensional

curve that is stable in two positions. These variations may not require a separate elastic spring to be bi-stable.

[0132] Optionally, back-and-forth reciprocating motion from a vacuum powered mechanism may be mechanically converted to rotational motion or rotary oscillation to provide rotational or rotary oscillation mechanical output by the mechanism.

[0133] A tissue evacuation shaft may be routed through the center of the drive Piston to provide an efficient method of transferring the mechanical output of the mechanism to the cutter at the window.

[0134] To prevent vacuum leakage in the motor, a thin plastic seal may be molded integral to a component and plastically deformed by squeezing the thin plastic seal in a die to increase its flexibility and conformability. This may reduce the cost of components and assembly labor, and it may improve the overall reliability of the mechanism. Optionally, flash formed at a parting line of a mold may be used as a seal because it is very thin and flexible and conforms to the geometry of mating components while maintaining minimal friction between components. An O-ring may optionally be used to create a seal between molded components.

[0135] In certain variations, a mechanism may include a Shuttle piston positioned or arranged adjacent to and/or parallel to the drive Piston such that overall mechanism and or device size is reduced, the transfer of mechanical motion between the pistons is easier and more efficient and the flow of air through the device is more efficient. This arrangement may allow for a smaller, easy to hold and use device. The shuttle and drive piston's may be coupled by a bi-stable switch.

[0136] A spring-loaded Trigger may directly or indirectly interact with the Shuttle piston or valve to turn the mechanism "ON" and "OFF." This reliably and consistently controls the mechanism function. The trigger may be designed to always stop the motor with the Cutter shaft proximal to the opening or cutting window thereby leaving the cutting window open such that the device may be used in "suction only" mode through the window. Additionally, a device cleaning tool, such as a declogger, may be threaded through the cutting window and proximally advanced through and/or along the tissue evacuation path to clear or remove obstructions in the tissue evacuation path.

[0137] A loop of flexible tubing that connects the evacuation shaft to a stationary connection on the device, such as a vacuum port, provides a low cost way to allow back-and-forth motion of the evacuation shaft and the mechanism without causing shaking, vibration or external motion of other tubing or components in a chamber or handle, and

without dislodging the evacuation path connection to the tissue collection chamber. The loop of tubing may change shape to accommodate the back-and-forth motion of the evacuation shaft.

**[0138]** The cutting device may be designed such that irrigant does not flow unless suction is present at the opening or cutting window to draw the irrigant, e.g., to provide a self-regulating supply of irrigant. This may be possible by supplying a reservoir of irrigant that is not pressurized relative to atmospheric air, however, when suction is applied to the reservoir, irrigant flows from the reservoir and toward the source of vacuum. An example of this is a syringe filled with irrigant that is connected to tubing; when suction is applied to the tubing, irrigant flows from the syringe and through the tubing toward the source of vacuum. This will ensure the irrigant does not unintentionally flow out of the device and leak into the patient where it may be problematic such as when aspirated by the patient (e.g., when the device is used in the respiratory passages), e.g., where a patient is under general anesthesia and can't communicate. An irrigant reservoir may be located within the handle of the device such that it may be filled by the operator as needed, thereby reducing the number of tubes and connections that are tethered to the cutting device.

**[0139]** A cutting device or microdebrider having a reciprocating or back-and-forth cutting motion may optionally be powered by an integrated supply of compressed air such as a CO<sub>2</sub> cartridge or by a battery, e.g., one that supplies electricity to a DC motor that actuates a cutter. This would allow the vacuum supply to be used entirely to draw tissue into the cutting window and to evacuate excised tissue thereby increasing or improving a resection rate. A separate power console is not necessary to provide power to the device.

#### Exemplary Vacuum Powered Mechanisms Or Motors

**[0140]** A vacuum powered or driven mechanism or motor used in various of the cutting devices described herein may be so called because it uses suction from an internal or external vacuum source to produce movement. The vacuum mechanism or motor does not create suction and is not to be confused with a vacuum pump. The Vacuum is used to power a mechanism to power a medical device which cuts and evacuates tissue or performs other work on tissue. A vacuum-powered mechanism generates the reciprocating or rotating motion of the cutter or other operable element of the device. The mechanism may be powered by the difference in ambient atmospheric air pressure on one side of a piston and a vacuum (or partial vacuum) on the opposite side of the piston in the chamber or cylinder in which the piston is positioned. In certain variations, the

mechanism may optionally utilize a biasing component, e.g., a spring, to motivate a piston in a direction or to cause a drive or return stroke of the piston.

**[0141]** One vacuum mechanism or motor described herein may be referred to as a double action vacuum powered mechanism or double action mechanism because it uses suction to move the piston in both directions. Vacuum or suction is alternately applied to either sides of a piston to cause the piston to alternately move back and forth in the direction of the vacuum (or partial vacuum). Vacuum mechanisms or motors that use a spring to return them to their starting position may be referred to as a spring action or spring return mechanism. . A single action mechanism or motor may use a vacuum to drive the piston in a single direction until the vacuum is vented and the piston is returned to its starting position by a spring.

**[0142]** One advantage of using vacuum to move the piston in both directions, as compared to using a spring to return the piston to its starting position, is that the efficiency of the motor is nearly doubled. A spring return mechanism must have a piston size and cylinder volume that is large enough to generate adequate force both to perform the work output required of the motor as well as to compress the return spring. The smaller piston size of a double action mechanism allows the mechanism to be incorporated into a handheld device. The spring on a spring-return motor must be adequately sized to reliably return the piston to its starting position with an adequate safety margin to reliably overcome friction and external forces on the mechanism.

**[0143]** Exemplary variations of vacuum driven mechanisms are described herein. Figures 3A-5B show various mechanisms in distal and proximal positions. The distal position refers to a piston in the mechanism being motivated in a direction toward the distal end of the cutting device in which the mechanism would be situated. Regarding the figures described below, from a viewer's perspective, the left side of the figures is the proximal side and the right side of the figures is the distal side. The proximal position refers to a piston in the mechanism being motivated in a direction toward the proximal end of the cutting device in which the mechanism would be situated.

**[0144]** Figure 3A shows a cross sectional view of a variation of a double action vacuum powered mechanism 310 or motor, similar to the mechanism 30, referred to above. The mechanism 310 includes a bi-stable switch. Figure 3A shows the mechanism 10 in a proximal position, while Figure 3B shows the double action vacuum powered mechanism in the distal position.

[0145] Referring to Figures 3A-3B, the vacuum powered mechanism 310 includes a drive piston 301 having a piston shaft 302. The drive piston 301 including at least a portion of the piston shaft 302 are positioned within a drive piston chamber 307. The drive piston 301 divides or separates the drive piston chamber into a proximal drive piston chamber 307a and a distal drive piston chamber 307b. The drive piston 301 may reciprocate proximally and distally within the drive piston chamber 307 when vacuum and ambient air are alternately applied to opposite sides of the drive piston 1 in drive piston chambers 307a and/or 307b. The piston shaft 302 may reciprocate along with the drive piston 301, and the reciprocating piston shaft 302 may conduct reciprocating motion output.

[0146] A bi-stable switch 303 is connected or coupled to a shuttle piston 314 and a switch spring 305. The switch spring 305 may cause the bi-stable switch 303 to quickly transition from a distal position to a proximal position and vice versa. The bi-stable switch is stable when it is in either a proximal position (Fig. 3A) or a distal position (Fig. 3B), but not when it is in between those two positions and therefore the switch resists residence in an in-between state. As a result, the mechanism does not “flutter” or the mechanism minimizes “flutter” when in transition between states. For example, the shuttle valve 313 may not flutter or not fail to fully transition from a proximal to a distal position or vice versa as the bi-stable switch causes the shuttle piston 314 and a shuttle valve 313 to transition or translate in the proximal or distal direction over and past a shuttle chamber vacuum supply port 308.

[0147] The bi-stable switch 303 may be actuated by the drive piston shaft 302 when the drive piston 1, and therefore the piston shaft 302, move in either the proximal or distal directions. Actuation of the bi-stable switch 303 results in movement of the shuttle piston 314 in either the proximal or distal directions. Movement of the drive piston in the proximal direction results in movement of the shuttle piston in the proximal direction via the bi-stable switch, while movement of the drive piston in the distal direction results in movement of the shuttle piston in the distal direction via the bi-stable switch.

[0148] The shuttle piston 314 is positioned within a shuttle piston chamber. The shuttle piston 314 includes a shuttle valve 313 or flange which may extend radially therefrom, which separates or divides the shuttle piston chamber into a proximal shuttle piston chamber 315 and a distal shuttle piston chamber 316. Proximal shuttle piston chamber 315 may be in fluid communication with proximal drive piston chamber 307a via

proximal vacuum slot 304. Distal shuttle piston chamber 316 may be in fluid communication with distal drive piston chamber 307b via distal vacuum slot 306.

**[0149]** The shuttle piston (314) may also include a proximal ambient air seal (309), a proximal cruciform (310), a distal ambient air seal (311), a distal cruciform (312), and a central shaft connecting the above components.

**[0150]** A shuttle piston chamber vacuum supply port (308) may be connected to an external or internal vacuum source or supply to evacuate the proximal shuttle piston chamber 315 and/or the distal shuttle piston chamber 316. The vacuum port 308 may allow for evacuation by vacuum of the proximal drive piston chamber 307a via the proximal vacuum slot 304 and the proximal shuttle piston chamber 315. The vacuum port 308 may allow for evacuation by vacuum of the distal drive piston chamber 307b via the distal vacuum slot 306 and the distal shuttle piston chamber 316.

**[0151]** For example, Proximal drive piston Chamber (307a) may be evacuated by vacuum when in fluid communication with the external vacuum source via the Vacuum Port (308), Proximal Shuttle piston Chamber (315), and proximal vacuum slot 304. Distal drive piston Chamber (307b) may be evacuated by vacuum when in communication with the external vacuum source via the Vacuum Port (308), Distal Shuttle piston Chamber (316), and distal vacuum slot 306. Presence of vacuum in Proximal drive piston Chamber 307a results in differential pressure between the proximal and distal sides of the Piston (301) that results in working force to move the Piston (301) proximally when ambient air is in the distal drive piston Chamber (307b). Alternately, ambient air (322) in proximal drive piston Chamber 307a applies working force to move the Piston (301) distally when the Distal drive piston Chamber (307b) is evacuated.

**[0152]** The shuttle piston 314 may be translated or positioned in a shuttle piston chamber such that Shuttle piston valve 313 can seal against the shuttle block (321) to the distal side of the vacuum port (308) to allow the proximal shuttle piston chamber (315) and/or proximal drive piston chamber (307a) to be evacuated by communicating with an external vacuum supply. Alternatively, the shuttle piston 314 may be translated or positioned in a shuttle piston chamber such that the shuttle piston valve 313 may seal against the shuttle block (321) to the proximal side of the vacuum port (308) to allow the distal shuttle piston chamber (316) and/or distal drive piston chamber (307b) to be evacuated by communicating with the external vacuum supply.

**[0153]** The proximal shuttle piston chamber (315) may allow for fluid communication between the Vacuum Port (308) and the Proximal drive piston Chamber (307a) through



the Proximal Vacuum Slot (304). The proximal shuttle piston chamber (3315) may also allow for fluid communication between the Proximal drive piston Chamber 307a and ambient air when the Proximal Shuttle Seal (309) is in the proximal position, i.e., an open or unsealed position.

[0154] The Distal Shuttle piston Chamber (316) may allow for fluid communication between the Vacuum Port (308) and the Distal drive piston Chamber (307b) through the Distal Vacuum Slot (306). The Distal Shuttle piston Chamber (316) may allow for fluid communication between the Distal drive piston Chamber 307b and ambient air when the Distal Shuttle Seal 311 is in the distal position, i.e., an open or unsealed position.

[0155] The proximal ambient air seal (309) of the shuttle piston 314 may seal against shuttle block (321) to prevent ambient air leakage into proximal shuttle piston chamber 315 when the proximal shuttle piston chamber (315) is evacuated. Also, the proximal cruciform (310) can maintain shuttle piston (314) position concentricity relative to proximal shuttle piston chamber (315), e.g., when the shuttle piston (314) moves to a proximal position and vents ambient air to the proximal shuttle piston chamber (315).

[0156] The distal ambient air seal (311) of the shuttle piston 314 may seal against shuttle block (321) to prevent ambient air leakage into distal shuttle piston chamber 316 when the distal shuttle piston chamber (316) is evacuated. Also, the distal cruciform (312) can maintain shuttle piston (314) position concentricity relative to distal shuttle piston chamber (316), e.g., when the shuttle piston (314) moves to a distal position and vents ambient air to the distal shuttle piston chamber (316).

[0157] The vacuum powered mechanism 310 may also include a Distal drive piston chamber Endcap (317), which may prevent or minimize fluid communication between ambient air and the Distal drive piston Chamber (307b) in addition to providing a sealing and bearing surface with the drive Piston Shaft (302). The vacuum powered mechanism 310 may also include a Distal drive piston chamber Endcap Seal (318), which may prevent or minimize ambient air leakage between the Distal drive piston chamber Endcap (317) and the drive piston Shaft (302), e.g., when the Distal drive piston Chamber (307b) is evacuated.

[0158] The vacuum powered mechanism 310 may also include a Proximal drive piston Chamber Endcap (319), which may prevent or minimize fluid communication between ambient air and the Proximal drive piston Chamber (37a) in addition to providing a sealing and bearing surface with the drive Piston Shaft (302). The vacuum powered mechanism or motor 310 may also include a Proximal drive piston Chamber Endcap Seal (320), which

may prevent or minimize ambient air leakage between the Proximal drive piston Chamber Endcap (319) and the drive Piston Shaft (302), e.g., when the Proximal drive piston Chamber (307a) is evacuated.

**[0159]** The drive piston shaft 302 may seal against the endplates or endcaps 317, 319 or shuttle block 321 to prevent or minimize loss of vacuum to ambient air 322. Also, various seals known to person of skill in the art may be utilized to seal the piston shaft against the endplates or endcaps 317, 319 or shuttle block 321.

**[0160]** A shuttle block 321 or other frame, structure, or casing may provide an outer structure for the vacuum powered mechanism 310. Ambient air 322 refers to air at atmospheric pressure which is located outside of the vacuum mechanism. Ambient air 322 may also be allowed to flow inside various chambers of the vacuum powered mechanism during use of the mechanism as described herein.

**[0161]** In use or in operation, the vacuum powered mechanism 310 operates by a pneumatic mechanism, method or logic that utilizes an external or internal vacuum source to provide the force to cause reciprocating motion of the drive piston 301 in both proximal and distal directions. A bi-stable switch may be utilized to transition the mechanism as it reverses or changes direction.

**[0162]** For example, the vacuum port 308 may be opened to the distal drive piston chamber 307b to evacuate the distal drive piston chamber 307b and ambient air is closed to the distal drive piston chamber 307b, while ambient air is opened to the proximal drive piston chamber 307a and the vacuum port is closed to the proximal drive piston chamber 307b. The drive Piston advances toward a distal position due to the vacuum inside the distal drive piston chamber 307b, on the distal side of the drive piston 301 and the ambient air pressure in the proximal cylinder chamber, on the proximal side of the drive piston 301.

**[0163]** As a result of the differential pressure created on opposite sides of the drive piston 301, the drive piston Rod or shaft 302 moves through its dwell until it contacts the bi-stable switch 303, causing the bi-stable switch 303 to rapidly change states from a proximal position to distal position, moving in the distal direction. The bi-stable switch is attached to the shuttle piston 314 and rapidly causes the shuttle 314 to move from a proximal position to distal position in the shuttle chamber. As a result, the vacuum seal 313 on the shuttle piston 314 moves from the proximal side of vacuum port 308 to the distal side of the vacuum port 308, opening the vacuum port 308 to the proximal drive piston chamber 307a to evacuate the proximal drive piston chamber 307a, and closing the

vacuum port 308 to the distal drive piston chamber 307b. Also, the distal seal 311 on the shuttle piston 314 opens the ambient air 322 to vent the distal drive piston chamber 307b to ambient pressure, and the proximal seal 309 on the shuttle piston 314 closes the ambient air vent to the proximal drive piston chamber 307a.

[0164] The drive piston 301 then reverses direction and moves in the proximal direction, due to the vacuum inside the proximal drive piston chamber 307a, on the proximal side of the drive piston and the ambient air pressure in the distal drive piston chamber, on the distal side of the drive piston 301.

[0165] As a result of the differential pressure created on opposite sides of the drive piston 301, drive piston Rod or shaft 302 moves through its dwell until it contacts the bi-stable Switch, causing the bi-stable switch to rapidly change states from a distal position to a proximal position. The bi-stable switch is attached to the Shuttle 314 and rapidly causes the Shuttle 314 to move from its distal position to a proximal position in the shuttle chamber. As a result, the vacuum seal 313 on the shuttle piston 314 moves from the distal side of the Vacuum Port 308 to the proximal side of the vacuum port 308, opening the vacuum port 308 to the distal drive piston chamber 307b to evacuate the distal drive piston chamber 307b, and closing the vacuum port 308 to the proximal drive piston chamber 307a. Also, the Proximal Seal 309 on the Shuttle piston 314 opens the ambient air 322 to vent the proximal drive piston chamber 307a to ambient pressure, and the Distal Seal 311 on the Shuttle piston 314 closes the ambient air vent to the distal drive piston chamber 307b.

[0166] Consequently, the mechanism has completed one cycle and is free to continue reciprocating as described above by alternating suction or air pressure on opposite sides of the piston, as long as adequate vacuum is available to the mechanism. Indeed, the above Steps may repeat as necessary such that the vacuum powered mechanism creates a reciprocating motion until the vacuum source is disconnected, turned off, or if the vacuum is inadequate to overcome the force required to move the drive piston 301 or if the mechanism 310 is stalled or stopped.

[0167] The reciprocating motion of the mechanism may be utilized to actuate a cutting device or to operate or actuate another device, e.g., another medical device. In certain variations, cutting device may be positioned by maneuvering a flexible or malleable shaft of the device e.g., manually or automatically. The shaft may be maneuvered or positioned around sensitive tissues or structures in the human body by changing the shape of the shaft. For example, extending or retracting an outer sheath or cannula on the shaft or

advancing or retracting the shaft relative to the outer sheath, thereby allowing improved maneuverability of the shaft around structures or within confined spaces may be performed, e.g., allowing a shaft's predetermined curvature to position the distal end of the shaft near a target site. Such mechanisms, techniques and devices include those described in US Patent Application Nos. 11/848,565, 11/848,564, and 11/848,562, each of which is incorporated herein by reference in their entirety for all purposes.

**[0168]** Figure 4A shows a cross sectional view of another variation of a double action vacuum powered mechanism or motor in a proximal position, while Figure 4B shows the double action vacuum powered mechanism or motor in a distal position.

**[0169]** Referring to Figure 4A-4B, the vacuum powered mechanism 430 includes a piston 431 having a piston shaft 432. The piston 431 including at least a portion of the piston shaft 432 are positioned within a cylinder chamber 437. The piston 431 divides or separates the cylinder chamber 437 into a proximal cylinder chamber 437a and a distal cylinder chamber 437b. The piston 431 may reciprocate proximally and distally within the cylinder chamber 437 when vacuum and ambient air are alternately applied to opposite sides of the piston 431 in cylinder chambers 437a and/or 437b. The piston 431 and piston shaft 432 may reciprocate, and the reciprocating piston shaft 432 may conduct reciprocating motion output.

**[0170]** A proximal shuttle pin 433 is connected to a shuttle 444. The shuttle pin 433 may be actuated by the piston 431 when the piston 431 moves in the proximal direction and contacts the proximal shuttle pin 433. Actuation of the proximal shuttle pin 433 by the piston results in movement of the shuttle 444 in the proximal direction.

**[0171]** A distal shuttle pin 435 is also connected to the shuttle 444. The distal shuttle pin 435 may be actuated by the piston 431 when the piston 431 moves in the distal direction and contacts the distal shuttle pin 435. Actuation of the distal shuttle pin 435 by the piston results in movement of the shuttle 444 in the distal direction. Indeed, movement of the piston in the proximal direction results in movement of the shuttle in the proximal direction via contact with the proximal shuttle pin 433, while movement of the piston in the distal direction results in movement of the shuttle in the distal direction via contact with the distal shuttle pin 435.

**[0172]** The shuttle 444 is positioned within a shuttle chamber. The shuttle 444 includes a shuttle valve 443 or flange which may extend radially therefrom, which separates or divides the shuttle chamber into a proximal shuttle chamber 445 and a distal shuttle chamber 446.

[0173] Proximal shuttle chamber 445 may be in fluid communication with proximal cylinder chamber 437a via proximal shuttle pin slot 434. Proximal shuttle pin slot 434 also provides an opening in which the proximal shuttle pin 433 may translate between proximal and distal positions. Distal shuttle chamber 446 may be in fluid communication with distal cylinder chamber 437b via distal shuttle pin slot 436. Distal shuttle pin slot 436 also provides an opening in which the distal shuttle pin 435 may translate between proximal and distal positions.

[0174] The shuttle (444) may also include a proximal ambient air seal (439), a proximal cruciform (440), a distal ambient air seal (441), a distal cruciform (442), and a central shaft connecting the above components.

[0175] A vacuum port (438) may be connected to an external or internal vacuum source or supply to evacuate the proximal shuttle chamber 445 and the distal shuttle chamber 446. The vacuum port 438 may allow for evacuation by vacuum of the proximal cylinder chamber 437a via the proximal shuttle pin slot 434 and the proximal shuttle chamber 445. The vacuum port may allow for evacuation by vacuum of the distal cylinder chamber 437b via the distal shuttle pin slot 436 and the distal shuttle chamber 446.

[0176] For example, Proximal Cylinder Chamber (437a) may be evacuated by vacuum when in fluid communication with the external vacuum source via the Vacuum Port (438), Proximal Shuttle Chamber (445), and Proximal Shuttle Pin Slot 434. Distal Cylinder Chamber (437b) may be evacuated by vacuum when in communication with the external vacuum source via the Vacuum Port (438), Distal Shuttle Chamber (446), and Distal Shuttle Pin Slot (436). Presence of vacuum in Proximal Cylinder Chamber 437a results in differential pressure between the proximal and distal sides of the Piston (431) that results in working force to move the Piston (431) proximally when ambient air is in the distal Cylinder Chamber (437b). Alternately, ambient air (422) in proximal Cylinder Chamber 437a applies working force to move the Piston (431) distally when the Distal Cylinder Chamber (437b) is evacuated.

[0177] The shuttle 44 may be translated or positioned in a shuttle chamber such that Shuttle valve 443 can seal against the shuttle block (451) to the distal side of the vacuum port (438) to allow the proximal shuttle chamber (445) and proximal cylinder chamber (437a) to be evacuated by communicating with an external vacuum supply. Alternatively, the shuttle 444 may be translated or positioned in a shuttle chamber such that the shuttle valve 443 may seal against the shuttle block (451) to the proximal side of the vacuum port

(438) to allow the distal shuttle chamber (446) and distal cylinder chamber (437b) to be evacuated by communicating with the external vacuum supply.

[0178] The proximal shuttle chamber (445) may allow for fluid communication between the Vacuum Port (438) and the Proximal Cylinder Chamber (437a) through the Proximal shuttle pin Slot (434). The proximal shuttle chamber (445) may also allow for fluid communication between the Proximal Cylinder Chamber 437a and ambient air when the Proximal Shuttle Seal (439) is in the proximal position, i.e., an open or unsealed position.

[0179] The Distal Shuttle Chamber (446) may allow for fluid communication between the Vacuum Port (438) and the Distal Cylinder Chamber (437b) through the Distal shuttle pin Slot (436). The Distal Shuttle Chamber (446) may allow for fluid communication between the Distal Cylinder Chamber 437b and ambient air when the Distal Shuttle Seal 41 is in the distal position, i.e., an open or unsealed position.

[0180] The proximal ambient air seal (439) of the shuttle 44 may seal against shuttle block (421) to prevent ambient air leakage into proximal shuttle chamber 445 when the proximal shuttle chamber (445) is evacuated. Also, the proximal cruciform (440) can maintain shuttle (444) position concentricity relative to proximal shuttle chamber (445), e.g., when the shuttle (444) moves to a proximal position and vents ambient air to the proximal shuttle chamber (445).

[0181] The distal ambient air seal (441) of the shuttle 444 may seal against shuttle block (51) to prevent ambient air leakage into distal shuttle chamber 446 when the distal shuttle chamber (446) is evacuated. Also, the distal cruciform (442) can maintain shuttle (444) position concentricity relative to distal shuttle chamber (446), e.g., when the shuttle (444) moves to a distal position and vents ambient air to the distal shuttle chamber (446).

[0182] The vacuum powered mechanism 430 may also include a Distal Cylinder Endcap (447), which may prevent or minimize fluid communication between ambient air and the Distal Cylinder Chamber (437b) in addition to providing a sealing and bearing surface with the Piston Shaft (432). The vacuum powered mechanism 430 may also include a Distal Cylinder Endcap Seal (448), which may prevent or minimize ambient air leakage between the Distal Cylinder Endcap (447) and the Piston Shaft (432), e.g., when the Distal Cylinder Chamber (437b) is evacuated.

[0183] The vacuum powered mechanism 430 may also include a Proximal Cylinder Endcap (449), which may prevent or minimize fluid communication between ambient air and the Proximal Cylinder Chamber (437a) in addition to providing a sealing and bearing

surface with the Piston Shaft (432). The vacuum powered mechanism 430 may also include a Proximal Cylinder Endcap Seal (450), which may prevent or minimize ambient air leakage between the Proximal Cylinder Endcap (449) and the Piston Shaft (432), e.g., when the Proximal Cylinder Chamber (437a) is evacuated.

[0184] The piston shaft 432 may seal against the endplates or endcaps 447, 449 or shuttle block 451 to prevent or minimize loss of vacuum to ambient air 422. Also, various seals known to person of skill in the art may be utilized to seal the piston shaft against the endplates or endcaps 447, 449 or shuttle block 451.

[0185] A shuttle block 451 or other frame, structure, or casing may provide an outer structure for the vacuum powered mechanism 430. Ambient air 422 refers to air at atmospheric pressure which is located outside of the vacuum powered mechanism. Ambient air 422 may also be allowed to flow inside various chambers of the vacuum powered mechanism during use of the mechanism as described herein.

[0186] In use or in operation, the vacuum powered mechanism 430 operates by a pneumatic mechanism, method or logic that does not require inertial mass to move the mechanism through transition (such as a flywheel) and that uses an external or internal vacuum source to provide the force to cause reciprocating motion of the piston 31 in both proximal and distal directions.

[0187] For example, the vacuum port 438 may be opened to the distal cylinder chamber 437b to evacuate the distal cylinder chamber 437b and ambient air is closed to the distal cylinder chamber 37b, while ambient air is opened to the proximal cylinder chamber 437a and the vacuum port is closed to the proximal cylinder chamber 437b. The Piston advances toward a distal position due to the vacuum inside the distal cylinder chamber 437b, on the distal side of the piston 431 and the ambient air pressure in the proximal cylinder chamber, on the proximal side of the piston 431.

[0188] As a result of the differential pressure created on opposite sides of the piston 431, the Piston 431 moves through the chamber and contacts the distal shuttle pin 435, causing the shuttle 444 to move from a proximal position to distal position in the shuttle chamber. As a result, the vacuum seal 443 on the shuttle 444 moves from the proximal side of vacuum port 438 to the distal side of the vacuum port 38, opening the vacuum port 438 to the proximal cylinder chamber 437a to evacuate the proximal cylinder chamber 437a, and closing the vacuum port 438 to the distal cylinder chamber 437b. Also, the distal seal 441 on the shuttle 444 opens the ambient air 422 to vent the distal cylinder

chamber 437b to ambient pressure, and the proximal seal 439 on the shuttle 444 closes the ambient air vent to the proximal cylinder chamber 437a.

[0189] It may be necessary to have adequate evacuated volume in the distal cylinder chamber 437b to cause the Piston (431) to continue translating distally after the Shuttle Valve (443) shuts off vacuum from vacuum port 438 to the distal cylinder chamber 437b. This may ensure that the shuttle 444 continues to translate in the distal direction as a result of the moving piston contacting the distal shuttle pin and thereby moving the shuttle 444, such that shuttle valve 443 completely passes vacuum port 438, shutting off the vacuum to the distal cylinder chamber 437b, in manner that avoids or minimizes valve flutter or unwanted fluctuation of the valve 443 between proximal and distal positions in the shuttle chamber.

[0190] The piston 431 then reverses direction and moves in the proximal direction, due to the vacuum inside the proximal cylinder chamber 437a, on the proximal side of the Piston and the ambient air pressure in the distal cylinder chamber 437b, on the distal side of the piston 431.

[0191] As a result of the differential pressure created on opposite sides of the piston 431, the piston 431 moves through its dwell or the cylinder chamber and contacts the proximal shuttle pin 433, causing the Shuttle 444 to move from its distal position to proximal position in the shuttle chamber. As a result, the vacuum seal 443 on the shuttle 444 moves from the distal side of the Vacuum Port 438 to the proximal side of the vacuum port 38, opening the vacuum port 438 to the distal cylinder chamber 37b to evacuate the distal cylinder chamber 437b, and closing the vacuum port 38 to the proximal cylinder chamber 437b. Also, the Proximal Seal 439 on the Shuttle 444 opens the ambient air 422 to vent the proximal Cylinder chamber 437a to ambient pressure, and the Distal Seal 441 on the Shuttle 444 closes the ambient air vent to the distal cylinder chamber 437b.

[0192] Again, it may be necessary to have adequate evacuated volume in the proximal cylinder chamber 437a to cause the Piston (431) to continue translating proximally after the Shuttle Valve (443) shuts off vacuum from vacuum port 438 to the proximal cylinder chamber 437a. This may ensure that the shuttle 444 continues to translate in the proximal direction as a result of the moving piston contacting the proximal shuttle pin and thereby moving the shuttle 444, such that shuttle valve 443 completely passes vacuum port 438, shutting off the vacuum to the proximal cylinder chamber 437b, in manner that avoids or minimizes valve flutter or unwanted fluctuation of the valve 443 between proximal and distal positions in the shuttle chamber.



[0193] Consequently, the mechanism has completed one cycle and is free to continue reciprocating as described above by alternating air pressure on opposite sides of the piston, as long as adequate vacuum is available to the mechanism. Indeed, the above Steps may repeat as necessary such that the vacuum powered mechanism creates a reciprocating motion until the vacuum source is disconnected, turned off, or if the vacuum is inadequate to overcome the force required to move the Piston 431.

[0194] In certain variations of a vacuum powered mechanism, a vacuum may be created in the “dead space” on the distal or proximal end of the Cylinder that is adequate to cause the Piston to continue moving distally or proximally after the external vacuum source is shut off from the Cylinder. The “dead space” volume in the proximal or distal end of the Cylinder serves as an “accumulator” that encourages the Piston to continue moving distally or proximally thereby eliminating the need for mass to create inertia to move the valve through transitions from one state to another.

[0195] In another variation, a method of reducing pneumatic valve instability or flutter caused by the valve or Shuttle attempting to move back and forth between states includes exposing one side of the shuttle valve to the vacuum source and the opposite side of the shuttle valve to ambient air. This may cause the shuttle valve to move in the direction of the vacuum and will more fully open the port connecting the ambient air to the Cylinder.

[0196] The reciprocating motion of the mechanism may be utilized to actuate a cutting device or to operate or actuate another device, e.g., another medical device. In certain variations, cutting device may be positioned by maneuvering a flexible or malleable shaft of the device e.g., manually or automatically. The shaft may be maneuvered or positioned around sensitive tissues or structures in the human body by changing the shape of the shaft. For example, extending or retracting an outer sheath or cannula on the shaft or advancing or retracting the shaft relative to the outer sheath, thereby allowing improved maneuverability of the shaft around structures or within confined spaces may be performed, e.g., allowing a shaft’s predetermined curvature to position the distal end of the shaft near a target site. Such mechanisms, techniques and devices include those described in US Patent Application Nos. 11/848,565, 11/848,564, and 11/848,562, each of which is incorporated herein by reference in their entirety for all purposes.

[0197] Further describing operations of a variation of a mechanism as illustrated in Figs. 4A-4B, the shuttle 444 may start in the proximal or distal positions. In certain variations, a small spring (not shown) may be used to position the piston and/or the shuttle component in a particular starting position.

[0198] Fig. 4A shows the shuttle 444 starting in the proximal position. When external vacuum is applied to the mechanism through the Vacuum Port (438), the Shuttle Valve (443) is on the proximal side of the Vacuum Port (448) which results in evacuation of the air in the Distal Cylinder Chamber (437b), the Distal Shuttle Pin Slot (436), and the Distal Shuttle Chamber (446). Consequently, the differential pressure on the proximal and distal sides of the Piston (431) causes the piston to move distally.

[0199] The vacuum may apply a force greater than the frictional forces acting on the Piston in addition to the forces required by the mechanism to perform work.

[0200] As the Piston (431) moves distally, it contacts the Distal Shuttle Pin (435) and moves the Shuttle (444) distally. As a result, the Shuttle Valve (443) closes off the Vacuum Port (438) to the distal side of the mechanism.

[0201] It may be necessary to have adequate evacuated volume on the distal side of the chamber or in the distal cylinder chamber 437b to cause the Piston (431) to continue translating distally after the Shuttle Valve (443) shuts off vacuum to the distal side of the mechanism or to the distal cylinder chamber 437b.

[0202] As the Shuttle (444) moves distally, the Distal Ambient Air Seal (441) opens to allow ambient air from outside of the mechanism to flow into the distal side of the mechanism and fill the evacuated volume including the Distal Cylinder Chamber (437b), the Distal Shuttle Pin Slot (436), and the Distal Shuttle Chamber (446). Additionally, the Proximal Ambient Air Seal (439) closes and the Shuttle Valve (443) opens the vacuum port 438 to the proximal side of the mechanism and/or to the proximal cylinder chamber 437a.

[0203] The Shuttle Valve (443) moves to the distal side of the Vacuum Port (438) which results in evacuation of the air in the Proximal Cylinder Chamber (437a), the Proximal Shuttle Pin Slot (434), and the Proximal Shuttle Chamber (445). Consequently, the differential pressure on the proximal and distal sides of the Piston (431) causes the piston to move proximally.

[0204] As the Piston (431) moves proximally, it contacts the Proximal Shuttle Pin (433) and moves the Shuttle (444) proximally. As a result, the Shuttle Valve (443) closes off the Vacuum Port (438) to the proximal side of the mechanism or to the proximal cylinder chamber 437a.

[0205] It may be necessary to have adequate evacuated volume on the proximal side of the chamber or in the proximal cylinder chamber 437a to cause the Piston (431) to

continue translating proximally after the Shuttle Valve (443) shuts off vacuum to the proximal side of the mechanism or to the proximal cylinder chamber 437a.

[0206] As the Shuttle (444) moves proximally, the Proximal Ambient Air Seal (439) opens to allow ambient air from outside of the mechanism to flow into the proximal side of the mechanism and fill the evacuated volume including the Proximal Cylinder Chamber (437a), the Proximal Shuttle Pin Slot (434), and the Proximal Shuttle Chamber (445). Additionally, the Distal Ambient Air Seal (441) closes and the Shuttle Valve (443) opens the vacuum port 8 to the distal side of the mechanism and/or the distal cylinder chamber 437b.

[0207] The Shuttle Valve (443) is on the proximal side of the Vacuum Port (438) which results in the mechanism being returned to the starting position described above. Consequently, the mechanism has completed one cycle and is free to continue reciprocating as described above as long as adequate vacuum is available to the mechanism.

[0208] Figures 5A-5B show another variation of a vacuum powered mechanism 560 or motor including a spring return mechanism. Fig. 5A shows the mechanism with a Piston 561 in a starting or proximal position, and Fig. 5B shows the mechanism with a Piston 561 in a distal position.

[0209] Referring to Figure 5A-5B, the vacuum powered mechanism 560 includes a piston 561 having a piston shaft 62. The piston 561 including at least a portion of the piston shaft 562 are positioned within a cylinder chamber 581. The piston 561 divides or separates the cylinder chamber 581 into a proximal cylinder chamber 581a and a distal cylinder chamber 581b. The piston 561 may reciprocate distally within the cylinder chamber 581 when the distal side of the piston 561 is evacuated or when distal cylinder chamber 581b is evacuated. Ambient air may be or may always be present on the proximal side of the piston 561 or in the proximal cylinder chamber 581a. Cylinder chamber 581a may be open to ambient air or may always be open to ambient air. The piston shaft 565 may reciprocate along with the piston 561, and the reciprocating piston shaft 565 may conduct reciprocating motion output. The piston shaft may serve to transmit the motion from the piston as the mechanism output.

[0210] A shuttle 562 may be connected to the Piston (561) and the shuttle 562 may reciprocate along with the Piston 561. The shuttle 562 may be positioned in a shuttle chamber. The shuttle includes a proximal seal flange 563 which may be integral to the shuttle 562 and/or extend radially therefrom. The seal flange 563 provides a seal between

the Ambient Air Conduit (574) and the Distal Cylinder Chamber (581b) when the Distal Cylinder Chamber (581b) is evacuated. Proximal Seal Flange 563 may also contact a Proximal Stop Pin (580) to stop the proximal movement of the Shuttle (562).

[0211] The shuttle may also include a shuttle valve 564, which may be integral to the shuttle and/or may extend radially therefrom. The shuttle valve 564 may separate or divide the shuttle chamber into a proximal shuttle chamber 588, on the proximal side of the valve 564, and a vacuum shuttle chamber 583 on the distal side of the valve 564. The Shuttle Valve 564 provides a seal, which may seal, e.g., against the shuttle block 578, to the distal or proximal side of the distal conduit 572. The shuttle valve 564 may provide a seal to the proximal side of the distal conduit 572 to open the distal conduit 572, and the distal cylinder chamber 581b, to a vacuum port 575 to allow the distal cylinder chamber 581b to be evacuated by communicating with an external vacuum supply.

[0212] The shuttle valve 564 may also provide a seal to the distal side of the distal conduit 572 to open the distal conduit 572, and the distal cylinder chamber 581b, to an ambient air conduit 574 to allow the distal cylinder chamber 581b to be open to ambient air.

[0213] The piston shaft 565 may be integral to the piston 61 on the proximal end of the piston shaft 565 and integral to the distal piston shaft 570 (i.e., the external portion of the piston shaft 565 located at the distal end of the piston shaft 565). A Shuttle Return Surface (566) is Integral to the Piston Shaft (565) and serves to contact the distal end of the Shuttle (562) to motivate it proximally when the Piston 561 and piston shaft 565 are translating in the proximal direction.

[0214] The piston shaft 565 may also include a Distal Seal Flange (567), which may extend radially therefrom. The distal seal flange 567 may seal ambient air in the return spring chamber 584, sealing off the return spring chamber 584 from the shuttle vacuum chamber 583. The distal seal flange may also provide a surface for a Return Spring (568) to act upon to motivate or translate the Piston Shaft (565) proximally or in the proximal direction during a return stroke.

[0215] A Return Spring (568), is positioned in the return spring chamber 584 and stores mechanical energy by compressing during the distal stroke of the mechanism, i.e., when the piston and piston shaft are moved in the distal direction. The mechanical energy is released when the Return Spring 568 motivates the Piston Shaft 565 proximally during the return stroke of the mechanism.

[0216] The mechanism 560 may include a Distal End Plate (569) which serves as a distal stop for the Return Spring (568).

[0217] The mechanism 560 may also include various conduits. A Proximal Conduit (571) may provide a connection or conduit for fluid communication between the Distal Cylinder Chamber (581b) and a Parallel Conduit (573). A Distal Conduit (572), as identified above, may provide a connection or conduit for fluid communication between the Proximal Shuttle Chamber (588) and the Parallel Conduit (573). The Parallel Conduit (573) may provide a connection or conduit for fluid communication between the Proximal Conduit (571) and the Distal Conduit (572). The Ambient Air Conduit (574) may provide a conduit to allow ambient air to vent proximal shuttle chamber 588 and Distal Cylinder Chamber (581b) depending on the positioning of shuttle valve 564 relative to the distal conduit 572.

[0218] The Vacuum Port (575) connects the mechanism to an external vacuum source and evacuates shuttle vacuum chamber 583 and may evacuate distal cylinder chamber 581b depending on the positioning of shuttle valve 564 relative to the distal conduit 572.

[0219] The mechanism 560 may also include a Return Spring Vent (576) which vents the Return Spring Chamber (584) to ambient air to maintain ambient air pressure in the Return Spring Chamber (584) as the chamber changes volume due to compression and extension of the Return Spring (568). The Return spring chamber 84 contains the return spring 68. The return spring chamber 84 may be or may always be at ambient pressure via the return spring vent 76.

[0220] A Distal Parallel Conduit (77) may also be provided. The distal parallel conduit 77 may be an Artifact from machining the mechanism Block (78) and the Distal Parallel Conduit 77 may be plugged at the distal end prior to use.

[0221] A mechanism block 578 or other frame, structure, or casing may provide an outer structure for the vacuum powered mechanism 560. Ambient air 522 refers to air at atmospheric pressure which is located outside of the vacuum powered mechanism. Ambient air 522 may also be allowed to flow inside various chambers of the vacuum powered mechanism during use of the mechanism as described herein.

[0222] A Distal Stop Pin (579) provides a distal stop for the Shuttle (562) by preventing distal translation of the Shuttle (562) beyond the location of the distal stop pin 579.

[0223] A Proximal Stop Pin and Ball Plunger (580) may provide a proximal stop for the Shuttle (562) when in contact with the Proximal Seal Flange (563). The Ball Plunger

provides normal force on the Shuttle to increase the force required to translate the shuttle laterally thereby reducing or eliminating the likelihood of valve “flutter” or unwanted fluctuation of the valve 564 between proximal and distal positions in the shuttle chamber relative to distal conduit 572.

[0224] The Distal Cylinder Chamber (581b) alternates between vacuum and ambient pressure to motivate the Piston (561) distally when the Distal Cylinder Chamber (581b) is in vacuum and to allow the Return Spring (568) to motivate the Piston Shaft (562) and/or piston 61 proximally when the Distal Cylinder Chamber 581b is at ambient pressure.

[0225] The Proximal Shuttle Chamber (588) may be at ambient pressure or may always be at ambient pressure. The Shuttle Vacuum Chamber (583) may be evacuated or may always be evacuated when an external vacuum source is connected to the Vacuum Port (575).

[0226] In use or in operation, the vacuum powered mechanism 560 operates by a pneumatic mechanism, method or logic whereby a vacuum mechanism valve sequence includes shutting off the vacuum source from the distal cylinder chamber 81b or the mechanism to allow the piston to return to its home position without venting the vacuum source to ambient pressure. As a result, the vacuum pressure remains consistent in the cutting and evacuation system portion of the device. The pneumatic mechanism, method or logic for a piston system that does not require inertial mass to move the mechanism through transition (such as a flywheel) and that uses an external or internal vacuum source to provide the force to cause reciprocating motion in one direction and a return spring to provide the force to cause reciprocating motion in the reverse direction may include the following steps.

[0227] For example, a vacuum may be open to the distal Cylinder chamber 581b while ambient air is closed to that chamber. The Piston 561 advances in the distal direction, toward a distal position due to the vacuum inside the distal cylinder chamber 521b and ambient pressure in the proximal cylinder chamber 581a, on the proximal side of the Piston 561. Distal advancement of the Piston 561 compresses the Compression Spring 568, where the vacuum force should or may be great enough to overcome friction in order to compress the Compression Spring 568.

[0228] When the piston 561 moves, the piston 561 contacts Shuttle 562 and advances the Shuttle 562 such that the shuttle valve 564 cuts off the vacuum to the distal Cylinder chamber 581b and the Compression Spring 568 continues to compress as the Piston 561 advances in the distal direction. Piston 561 may continue to advance distally (e.g., even

after the vacuum is cut off to distal cylinder chamber 581b) due to evacuated volume on the distal side of the Cylinder in the distal cylinder chamber 581b, which should or may be great enough to overcome friction and to continue compressing the Compression Spring 568 and advancing the shuttle 562 to allow ambient air to flow into the distal cylinder chamber 581b by opening distal conduit 572 and distal cylinder chamber 581b to ambient air conduit 574.

**[0229]** The Piston 561 may retract in the proximal direction to a proximal position due to the force of the Compression Spring 568 and a loss of vacuum in the distal cylinder chamber 581b resulting from ambient air flowing into the distal cylinder chamber 581b. The Piston Shaft 562 contacts the Shuttle and moves the shuttle in a proximal direction, thus cutting off ambient air conduit 574 and ambient air flow to the distal Cylinder chamber 581b. The Piston Shaft 562 continues moving the Shuttle 562 proximally, eventually opening the distal conduit 572 and distal cylinder chamber 581b to vacuum port 575 such that the vacuum connection is open to the distal cylinder chamber 581b.

**[0230]** The mechanism is free to continue reciprocating as described above by creating a pressure differential on opposite sides of the piston as long as adequate vacuum is available to the mechanism. The above steps may repeat as necessary such that the vacuum powered motor creates a reciprocating motion unless or until the vacuum source is disconnected, turned off, or if the vacuum is inadequate to overcome the force required to compress the Compression Spring and overcome the internal friction or if the mechanism is stalled or halted.

**[0231]** In certain variations, Pneumatic valve instability or flutter caused by the shuttle or shuttle valve attempting to move back and forth between states, or between proximal and distal positions relative to distal conduit 572, may be reduced or eliminated by exposing one side of the shuttle valve 564 to the vacuum source and the opposite side of the Shuttle valve 564 to ambient air. This will cause the Shuttle or shuttle valve to move in the direction of the vacuum and will more fully open the distal conduit 572 to the ambient air conduit 574, thereby connecting the ambient air to the distal Cylinder chamber 581b.

**[0232]** In certain variations, a small normal force may be imparted on the Shuttle 562 to hold it in place to overcome unintended movement caused by friction against the Piston Shaft 565 or valve flutter caused by valve instability. This small normal force may be imparted in the form of a ball plunger.

[0233] In certain variations of a vacuum powered mechanism, an adequate volume is evacuated on the distal end of the Cylinder or from the distal cylinder chamber to cause the Piston to continue moving distally after the external vacuum source is shut off from the distal Cylinder chamber. The evacuated volume in the distal Cylinder chamber serves to encourage the Piston to continue moving distally after the external vacuum source is shut off from the volume of the distal cylinder chamber, thereby eliminating the need for inertial mass to move the valve through transitions from one state to another.

[0234] The reciprocating motion of the mechanism may be utilized to actuate a cutting device or to operate or actuate another device, e.g., another medical device. In certain variations, cutting device may be positioned by maneuvering a flexible or malleable shaft of the device e.g., manually or automatically. The shaft may be maneuvered or positioned around sensitive tissues or structures in the human body by changing the shape of the shaft. For example, extending or retracting an outer sheath or cannula on the shaft or advancing or retracting the shaft relative to the outer sheath, thereby allowing improved maneuverability of the shaft around structures or within confined spaces may be performed, e.g., allowing a shaft's predetermined curvature to position the distal end of the shaft near a target site. Such mechanisms, techniques and devices include those described in US Patent Application Nos. 11/848,565, 11/848,564, and 11/848,562, each of which is incorporated herein by reference in their entirety for all purposes.

[0235] Further describing operations of a variation of a mechanism as illustrated in Figs. 5A-5B, Fig. 5A shows a starting position for the mechanism with the Piston in a proximal position due to extension of the Return Spring (568).

[0236] When external vacuum is applied to the mechanism through the Vacuum Port (575), the Shuttle Valve (564) is on the proximal side of the Vacuum Port (75) and on the proximal side of the Distal Conduit (572). As a result, the vacuum is able to fluidly communicate with the Distal Cylinder Chamber (581b) which results in evacuation of the air in the Distal Cylinder Chamber (581b). Consequently, the differential pressure on the proximal and distal sides of the Piston (561) causes the piston to move distally.

[0237] As the Piston (561) moves distally, it compresses the Return Spring (568) thereby storing mechanical energy. The Proximal Shuttle Seal (563) prevents leakage of ambient air into the Distal Cylinder Chamber (581b). The Shuttle (562) "dwells" in position until the Piston (561) contacts the Shuttle (562) and motivates it in the distal direction. The Shuttle Valve (564) then closes off the Vacuum Port (575) to the Distal Conduit (572) thereby shutting off vacuum to the Distal Cylinder Chamber (581b).



[0238] It may be necessary to have adequate evacuated volume on the distal side of the chamber in the distal cylinder chamber 581b to cause the Primary Piston (561) to continue translating distally after the Shuttle Valve (564) shuts off vacuum to the distal conduit 572 and the distal cylinder chamber 581b.

[0239] As the Distal Cylinder Chamber (581) refills with ambient air, from ambient air conduit 574 via distal conduit 572 (which is now open to ambient air conduit 514 as shown in Fig. 5b), the Return Spring (568) motivates the Piston Shaft (565) proximally.

The Shuttle “dwells” in position until the Shuttle Return Surface (566) on the Piston Shaft (565) contacts the Shuttle (562) and motivates the Shuttle (562) in the proximal direction.

[0240] The Shuttle Valve (564) moves from the distal side to the proximal side of the Distal Conduit (572) thereby opening the distal conduit 572 to the Vacuum Port (575) to evacuate the Distal Cylinder Chamber 581b).

[0241] The Shuttle (562) and the Piston 561 return to their proximal (starting) position and the mechanism has completed one cycle and is free to continue reciprocating as described above as long as adequate vacuum is available to the mechanism.

[0242] Mechanism utilizing a Poppet Valve

[0243] In certain variations, a medical device driven or powered by a vacuum source may include a working end having an operable element. The operable element may be coupled to a mechanism, such that when the mechanism is driven by the vacuum source movement of a drive piston or drive shaft of the mechanism results in actuation of the operable element. The drive piston or drive shaft may be located at least partially in a chamber and may be moveable between a drive stroke and a return stroke. The mechanism may include a valve configured to alternately seal and vent at least a portion of the chamber. The mechanism may also include a biasing component positioned against the drive piston or drive shaft. Evacuation of the chamber and movement of the biasing component when the chamber is vented to ambient air may cause the drive piston and/or drive shaft to cycle between a drive stroke and a return stroke to create a reciprocating motion. This reciprocating motion causes actuation of an operable element or shaft coupled to the mechanism.

[0244] Figures 11A-11E show a variation of a vacuum powered mechanism 600 or motor which may be used in various medical devices. For example, the mechanism 600 may be utilized in medical devices for cutting tissue or for performing other work on tissue or on a patient.

[0245] The mechanism 600 includes a Drive piston 601 attached to a drive piston shaft 602. The drive piston 601 and at least a portion of the drive piston shaft 602 are positioned in a chamber. The drive piston shaft divides the chamber into an evacuation or suction chamber 611 and a vent chamber 612. The Drive piston 601 translates proximally (to the left when referencing figures 11A-11E) when air is evacuated from the evacuation or suction chamber 611 and translates distally (to the right when referencing figures 11A-11E) when ambient air is vented into the suction chamber 611.

[0246] The Drive piston shaft 602 may be integrated with or otherwise coupled or connected to the drive piston 601. The Drive piston shaft 602 reciprocates along with the drive piston 601 and conducts linear reciprocating motion to provide output motion from the mechanism 600 to an output shaft, elongate shaft, evacuation shaft, operable element or tool, e.g., to actuate an operable element coupled to an output or evacuation shaft or directly to the mechanism 600. The Drive piston shaft 602 seals against mechanism body 606 at the mechanism body seal 614 to prevent loss of vacuum or suction from suction chamber 611 to ambient air. Drive piston shaft 602 rides or sits on the end cap bearing 613 to maintain concentricity between the Drive Piston 601 and the mechanism Body 606. An airtight seal may be provided between the drive piston shaft 602 and the end cap bearing 613, but an airtight seal may not be necessary. Drive Piston Shaft 602 may contain a lumen 616 to fluidly connect a source of suction to the Suction Chamber 611 and/or optionally to a working end of the device to facilitate tissue evacuation through the Drive Piston Shaft lumen 616.

[0247] Vacuum powered mechanism 600 also includes a valve, e.g., a poppet valve 603 or similar valve. The poppet Valve 603 alternately seals and vents the Suction Chamber 611 by opening and closing the Drive piston Cross-hole 605. The Poppet Valve 603 is held in place against the Drive Piston Cross-hole 605 by suction in the Suction Chamber 611 and ambient air in the Vent Chamber 612. When the Poppet Valve 603 seals the Drive piston Cross-hole 605 closed, air is evacuated from the Suction Chamber 611 and ambient air on the right side of the Drive Piston 601 in the vent chamber 612 translates the drive piston 601 to the left. When the Poppet Valve 603 is not sealing the Drive piston Cross-hole 605, ambient air flows through the Drive piston Cross-hole 605 and into Suction Chamber 611 thereby allowing a biasing component, e.g., a Return Spring 609, which may surround at least a portion of the drive piston shaft 602 or be otherwise positioned against the drive piston 601, to translate the Drive Piston 601 to the right such that the Poppet Valve 603 seals against the Drive piston Cross-hole 605.

[0248] The Drive Piston Cross-hole 605 allows ambient air to flow into the Suction Chamber 611 to cause the Drive Piston 601 to translate to the right. The drive piston cross hole 605 seals against the Poppet Valve 603 to allow air within the Suction Chamber 611 to be evacuated thereby translating the Drive Piston 601 to the left.

[0249] The poppet valve 603 may include or be coupled to a Poppet Valve Spring 604, which compresses when the Poppet Valve 603 translates to the left along with the Drive Piston 601. The poppet valve spring 604 can limit travel or leftward translation of the Poppet Valve 603 either by fully compressing or by exerting a force on the Poppet Valve 603 that is adequate to break the seal between the Poppet Valve 603 and the Drive Piston Cross-hole 605. When the seal between the Poppet Valve 603 and the Drive Piston Cross-hole 605 is broken the poppet valve spring 604 translates the poppet valve 603 to the right.

[0250] The mechanism Body 606 forms the outer shell of the mechanism 600 and seals the interior components, forming a seal with the Drive Piston 601 to separate the Suction Chamber 611 from the Vent Chamber 612. The mechanism body 606 seals against the Drive Piston Shaft 602 to prevent leakage of air into the Suction Chamber 611 by ambient air outside the mechanism 600.

[0251] The drive piston shaft 602 may include a Drive Piston Shaft Vent 607, which fluidly connects the Suction Chamber 611 to the external suction source through a lumen 616 in the Drive Piston Shaft 602.

[0252] The mechanism body 606 may also include a mechanism Body Vent 608. The mechanism body vent 608 maintains and allows for the flow of ambient air in the Vent Chamber 612.

[0253] The biasing component or Return Spring 609 positioned on or around at least a portion of the Drive Piston Shaft 602 or against the Drive Piston 601 translates the Drive Piston 601 to the right when the Suction Chamber 611 is vented to ambient air through the Drive Piston Cross-hole 605.

[0254] The mechanism 600 may also include an End Cap 610. The End Cap 610 may serve as a bearing surface for the Poppet Valve 603 and the Drive Piston Shaft 602, which may extend therethrough. The end cap 610 also provides a registration surface for the Poppet Valve Spring 604 as it compresses and extends to actuate the Poppet Valve 603.

[0255] Air may be continuously evacuated from the Suction Chamber 611 through the Drive Shaft Piston Shaft Vent 607. When the Drive Piston Cross-hole 605 is closed, air is evacuated from the suction chamber 611, causing the pressure to decrease inside the Suction Chamber 611 while the ambient air pressure on the right side of the Drive Piston

601 in the Vent Chamber 612 has greater air pressure than the air pressure in the Suction Chamber 611. This causes the Drive Piston 601 and drive piston shaft 602 to translate to the left, i.e., toward the Suction Chamber 611.

[0256] The Vent Chamber 612 may remain vented to ambient air. The Vent Chamber 612 maintains ambient air pressure against the right Drive Piston 601 to help translate the Drive Piston 601 and Drive Piston Shaft 602 to the left when the Drive Piston Cross-hole 605 is closed and the suction chamber 611 is evacuated.

[0257] The End Cap Bearing 613 may maintain concentricity between the Drive Piston 601 and the mechanism body 606 via the Drive Piston Shaft 602, which extends through or rides on the End Cap Bearing 13. An airtight seal is not necessary between the Drive Piston Shaft 602 and the End Cap Bearing 613 but may be provided.

[0258] The mechanism Body Seal 614 maintains an airtight seal between the Drive Piston Shaft 602 and the mechanism Body 606 to prevent leakage of ambient air into the Suction Chamber 611. The Drive Piston Seal 615 maintains an airtight seal between the Drive Piston 601 and the mechanism Body 606 to prevent leakage of ambient air into the Suction Chamber 611 from the Vent Chamber 612.

[0259] Figures 11A-11E illustrate the operation of vacuum powered mechanism 600 described above. The pneumatic method for the mechanism 600 or piston system includes the utilization of a Poppet Valve or other valve to reverse the Drive Piston direction. The mechanism 600 may use an external vacuum source to provide force to cause reciprocating motion in one direction and a Return Spring to provide force to cause or assist reciprocating motion in the opposite direction. The method of operation may include one or more of the following steps.

[0260] As shown in Figure 11A, at the beginning of the mechanism cycle, the Poppet Valve 603 may be opposed to the Drive Piston 601, sealing the Drive Piston Cross-hole 605. At least a portion of the air (the flow of suction air in the mechanism is identified by the arrows A) flows through the Drive Piston shaft lumen 616 as a result of suction provided by a vacuum source. As the air is evacuated from the Suction Chamber 611 on the left side of the Drive Piston 601, the vacuum builds on the left side of the Drive Piston 601 and the Drive Piston 601 and Drive Piston Shaft 602 translate to the left. The suction within the Suction Chamber 611 holds or pulls the Poppet Valve 603 closed, against the Drive Piston Cross-hole 605, even as the Drive Piston 601 moves or translates to the left.

[0261] As shown in Figure 11B, as the Drive Piston 601, Drive Piston Shaft 602 and the Poppet Valve 603 translate to the left, as a result of the evacuation of air from the

suction chamber 611 on the left side of the Drive Piston 601, the Poppet Valve Spring 604 and the Return Spring 609 are compressed.

[0262] As shown in Figure 11C, the Poppet Valve 603 translates to the left until it reaches the end of its stroke, where the Poppet Valve Spring 604 is fully compressed and the Poppet Valve 603 can no longer translate to the left. However, the Drive Piston 601 and drive piston shaft 602 are capable of continuing translation to the left after the poppet valve 603 reaches the end of its stroke, and as a result, the poppet Valve 603 disengages from the Drive Piston Cross-hole 605 (as shown in Figure 11D).

[0263] In an alternative variation, the Poppet Valve Spring 604 may not be fully compressed; however, the poppet valve spring may be able to apply adequate force to overcome the suction force holding the Poppet Valve 603 against the Drive Piston 601 and drive piston cross-hole 605, thereby disengaging the Poppet Valve 603 from the Drive Piston Cross-hole 605.

[0264] As shown in Figure 11D, after the Poppet Valve 603 loses its seal against the Drive Piston Cross-hole 605, the Poppet Valve 603 translates to the right, translating or springing to the right, back to its home position via the Poppet Valve Spring 604. The suction chamber 611 on the left side of the Drive Piston 603 is now vented to atmosphere air through the mechanism body vent 608 (venting or atmosphere air flow is indicated by the arrows B) as the drive piston cross-hole 605 is now open to atmosphere via the mechanism body vent 608. The Drive Piston 601 and drive piston shaft 602 then translate to the right, pushed by the compressed Return Spring 609 on the left side of the Drive Piston 601.

[0265] As shown in Figure 11E, the drive piston 601 and drive piston shaft translate to the right and return to their home position, and once again the drive piston 601 is sealed against the Poppet Valve 603 where the cycle may start again.

[0266] The above steps may repeat unless the vacuum source is disconnected, turned off, or if the vacuum is inadequate to overcome the force required to move the Drive Piston 601.

[0267] The vacuum powered mechanism 600 may be utilized to operate a variety of medical devices used for performing various types of work on tissue. For example, in one variation, the mechanism may be used in the cutting device shown in figures 1A-1H. The vacuum powered mechanism 600 may be substituted for or used as an alternative to the mechanism 30, shown in Figures 1A-1H, to provide power or create reciprocating motion

in the device, to create an output motion to cut tissue. In certain variations, the mechanism 600 may be used in combination with the mechanism 30

[0268] Figures 12A-12D show a variation of a medical device where the mechanism 600 is integrated in a variation of a tissue cutting or resecting device as described herein

[0269] Figure 12A shows a cross sectional view of a suction or vacuum powered cutting device 620 including a vacuum or suction powered mechanism 600. Figures 12B-12D show cross sectional views of the mechanism 600 of cutting device 620. The vacuum powered cutting device 620 may include an elongate shaft 621. The elongate shaft 621 may include a window 622 or cutting window or opening positioned at or near a distal end of the elongate shaft 621. An evacuation shaft may be positioned within the elongate shaft 621 and a cutter (not shown, but as described supra) may be positioned within the elongate shaft 621, e.g., coupled or connected to the distal end of the evacuation shaft. A proximal portion of the evacuation shaft 623 may be coupled to the drive piston shaft 602 of mechanism 600, such that the evacuation shaft 623 and the cutter may be reciprocated as the drive piston shaft 602 is reciprocated, causing the cutter to reciprocate past the opening 622. Other types of cutters are contemplated, e.g., the cutter may extend from a wire or blade positioned in the elongate shaft 621 and coupled to the drive piston shaft 602.

[0270] In any of the variations of vacuum powered mechanisms described herein, O-rings or other sealing components may be used to create a seal between surfaces but are not necessary if leakage around the seals is tolerable. Also, leakage around the seals may be reduced by using a lubricant of sufficient viscosity to fill the gap between the seal and the bore in which it operates.

[0271] The Shuttle may be configured in several positions including concentric with the Center Shaft, parallel to the Center Shaft, as a rotary valve, and so forth.

[0272] The vacuum powered mechanisms described herein may be utilized with or incorporated into a variety of medical devices. For example, the vacuum powered mechanisms may be utilized to reciprocate a cutter on a distal end of a malleable shaft which may be manipulated or adjusted manually or automatically or a flexible shaft having a predetermined curvature which is manipulated through advancement or retraction through a cannula or other sheath as illustrated and described in US Patent Application Nos. 11/848,565, 11/848,564, and 11/848,562, each of which is incorporated herein by reference in their entirety for all purposes. US Patent Application No. 61/360,429 is also incorporated herein by reference in its entirety for all purposes.

[0273] In certain variations of a device having a curved flexible shaft, a rigid or semi-rigid straight sheath may be assembled or connected to the device to cause the curved, flexible portion of the shaft to straighten as the sheath is advanced over the curved section or to cause the curved, flexible portion of the shaft to return to its curved shape as the sheath is retracted.

[0274] In other variations, a rigid or semi-rigid curved sheath may be assembled or connected to a device or end effector having a shaft with a curved, flexible portion to direct the shaft as it is advanced through the curved sheath.

[0275] In other variations, a rigid or semi-rigid curved sheath may be assembled or connected to a device or end effector having a shaft with a straight, flexible portion to direct the shaft as it is advanced through the curved sheath. The rigid or semi-rigid curved or straight sheaths may be assembled, connected, attached to or otherwise utilized with the cutting device. The various sheaths may be detachable from the devices or end effectors or affixed or attached to the devices and or end effectors.

[0276] In certain variations, the vacuum powered mechanisms described herein may also be utilized to reciprocate or actuate a reciprocating cutter of a device or end effector or to operate a device having a semi-rigid or rigid, curved end effector or a rigid or stiff shaft. A cutter, end effector and/or device may be operated by vacuum powered mechanisms or other motorized mechanisms or by hand.

[0277] Fig. 6 shows one variation of a rigid, curved end effector 4.0 or distal end of a device. The end effector 4.0 may include a scraping edge 4.1, a window 4.6, a reciprocating cutter 4.2., and/or a blunt distal tip 4.5. The end effector 4.0 may also include a rigid shaft 4.7. The rigid shaft 4.7 may have a shaft curvature section 4.3 and/or a shaft straight section 4.4. In certain variations, a fluid line 4.8, e.g., a saline line, may be attached to the end effector 4.0 or extend along or within the end effector 4.0. In certain variations, the end effector, distal end of a device, and/or shaft may be rigid, stiff, substantially rigid, or semi rigid.

[0278] The end effector 4.0 may be a component of a device, e.g., a cutting device or medical device. The end effector 4.0 may be positioned at a distal end of a cutting device or designed for use or attachment to a cutting device, medical device, or other device. The end effector 4.0 may be useful for various procedures requiring cutting and/or scraping of a variety of tissues including soft and hard tissues.

[0279] The Scraping Edge 4.1 is typically made from a rigid material, e.g., Stainless Steel, which may withstand cutting forces without substantially bending or deflecting the

scraping edge 4.1. Other materials may be used as warranted by the desired clinical application. In certain variations, a semi-rigid material may be used. The Scraping Edge 4.1 may be used to cut or scrape various soft and hard tissues, such as intradiscal nucleus tissue, Vertebral End Plates, cartilage, ligament, bone, and other soft and hard tissues. The Scraping Edge 4.1 may be used to cut tissue free and/or to mobilize the tissue for evacuation through the Window 4.6 and through a lumen of the rigid shaft 4.7. The tissue may be evacuated to a Filter or collection receptacle.

[0280] The Scraping edge 4.1 may be affixed or attached to the rigid shaft 4.7 at any angle relative to the longitudinal axis of the Rigid Shaft 4.7. For example, the scraping edge 4.1 may be affixed or attached to the Rigid Shaft 4.7 at an angle ranging from or between 0 to 180 degrees or 0 to 90 degrees relative to an axis of the Rigid Shaft 4.7. As shown in Fig. 6, in certain variations, the Scraping Edge 4.1 may be affixed or otherwise attached to the Rigid Shaft 4.7 in a position that is perpendicular or substantially perpendicular to the axis of the rigid shaft 4.7.

[0281] Where the Scraping Edge 4.1 is rigidly affixed to the Rigid Shaft 4.7 as shown in Figure 6, the cutting and scraping actions of the scraping edge 4.1 may be accomplished by the operator manually moving the Scraping Edge 4.1 through manual movement of the rigid shaft 4.7 or the end effector 4.0 or a component thereof. Optionally, the cutting and scraping actions of the scraping edge 4.1 may be accomplished automatically or by motorized movement or operation of the rigid shaft 4.7 or the end effector 4.0 or a component thereof.

[0282] In certain variations, the Scraping Edge 4.1 may be affixed or attached to the Reciprocating Cutter 4.2, e.g., external to the Rigid Shaft 4.7, such that the scraping edge 4.1 can reciprocate in concert with the cutter (not shown). The scraping edge 4.1 may be affixed or attached to the reciprocating cutter 4.2 at any angle relative to the longitudinal axis of the Reciprocating Cutter 4.2. For example, the scraping edge 4.1 may be affixed or attached to the Reciprocating Cutter 4.2 at an angle ranging from or between 0 to 180 degrees or 0 to 90 degrees relative to an axis of the Reciprocating Cutter 4.2. In certain variations, the Scraping Edge 4.1 may be affixed or otherwise attached to the Reciprocating Cutter 4.2 in a position that is perpendicular or substantially perpendicular to the axis of the Reciprocating Cutter 4.2.

[0283] The Scraping Edge 4.1 may be positioned at a location distal to the Window 4.6 and/or the scraping edge 4.1 may be predominately aligned with the Window 4.6 and/or positioned on the same side of the Rigid Shaft 4.7 as the Window 4.6. The



Scraping Edge 4.1 may be positioned distal or proximal to the Window 4.6. Optionally, the scraping edge 4.1 may have exposed scraping surfaces at any location around the periphery of the Rigid Shaft 4.7 or reciprocating cutter 4.2.

[0284] In certain variations, the end effector 4.0 may be built without a Scraping Edge 4.1. Indeed, an end effector 4.0 may or may not include a scraping edge 4.1 depending on the desired clinical application. In certain variations, one or more scraping edges may be positioned on an end effector, e.g., a plurality of scraping edges may be positioned on an end effector.

[0285] Still referring to Fig. 6, the Reciprocating Cutter 4.2 may be positioned on the end effector 4.0 such that the reciprocating cutter 4.2 may advance and/or retract axially past the Window 4.6 to excise and evacuate tissue or mobilized tissue. The Reciprocating Cutter 4.2 may use a “scissor” action against the window 4.5 or against a section of the rigid shaft 4.7 to excise tissue.

[0286] The Window 4.6 is an opening in the Rigid Shaft 4.7 that permits the passage of tissue into the window 4.6 and into the path of the Reciprocating Cutter 4.2 such that the tissue can be cut and/or evacuated. The Window 4.6 or at least a portion of the perimeter or an edge of the window 4.6 may serve as a cutting edge to “plane” tissue and excise the tissue. Additionally, an edge of the Window 4.6 may provide a surface with which the Reciprocating Cutter 4.2 may scissor tissue as the reciprocating cutter 4.2 passes by the Window 4.6.

[0287] Optionally, the end effector may include a flexible feature that encourages the Cutter 4.2 against the Window 4.6 to improve the scissoring action.

[0288] The Reciprocating Cutter 4.2 may be powered or actuated by any of the vacuum powered mechanisms described herein. Alternatively, the reciprocating cutter 4.2 or end effector may be actuated through a mechanism that is powered by hand or by other motorized mechanisms. In certain variations, a rotating cutter may be utilized and powered by any of the vacuum powered mechanisms described herein, by hand or by other motorized mechanisms.

[0289] The Rigid Shaft 4.7 may serve as the primary structure and/or outer envelope of the shaft of a device or cutting device to which the end effector is attached. The Rigid Shaft 4.7 may be curved or straight or the rigid shaft 4.7 may include curved and/or straight sections or portions. In certain variations, the rigid shaft 4.7 may be malleable to allow an operator or user to adjust or revise the curvature of the shaft 4.7 depending on the application or use. For example, the rigid shaft 4.7 may be bendable or the rigid shaft 4.7

may be annealed or softened in order to alter the shape or curve of the rigid shaft 4.7 by hand or machine. The rigid shaft may be annealed over the bendable portion of its length and hard near the distal extremity to reduce the likelihood of bending or damaging the shaft near the cutting window.

[0290] As shown in Figure 6, a Shaft Curvature section 4.3 may be provided in the rigid shaft 4.7. The rigid shaft may include one or more shaft curvature sections. The shaft curvature section 4.3 allows the operator to position the end effector 4.0 or the distal end of the end effector 4.0 or the distal end of the cutting device or other device in an area of anatomy outside of the line-of-sight of the user. For example, the shaft curvature section 4.3 may allow the end effector 4.0 to be positioned within an intradiscal space. The radius of curvature of the rigid shaft 4.7 or the shaft curvature section 4.3 may be determined during manufacturing or it may be operator-adjustable.

[0291] The rigid shaft 4.7 may also include a Shaft Straight Section 4.4 which may be located proximal to the Shaft Curvature section 4.3. The rigid shaft may include one or more shaft straight sections.

[0292] A Blunt Distal Tip 4.5 may be provided on the end effector 4.0. The blunt distal tip 4.5 may significantly reduce, minimize or eliminate the likelihood of the end effector 4.0 or distal end of a device accidentally being advanced through or into tissue which is not the intended target. For example, the blunt distal tip 4.5 may reduce the likelihood or minimize the risk of the end effector 4.0 or distal end of the device being advanced through an annulus when the end effector 4.0 of a device is being used to cut intra-discal nucleus or for scraping and/or evacuating vertebral endplate material. The blunt distal tip 4.5 may cover all or a portion of the distal surface of the Scraping Edge 4.1. In variations where the entire distal surface or substantially the entire surface of the Scraping Edge 4.1 is covered with the Blunt Distal Tip 4.5, the Scraping Edge 4.1 may cut and/or scrape only when moved in the proximal direction or a lateral direction and not when moved in the distal direction. In other variations where the entire distal surface or substantially all of the distal surface of the Scraping Edge 4.1 is covered with the Blunt Distal Tip 4.5, the Scraping Edge 4.1 may cut and/or scrape in the distal direction or it may cut and/or scrape in the distal direction in a limited manner.

[0293] In certain variations, a fluid line 4.8 may be affixed or attached to the external or outside surface of the Rigid Shaft 4.7 as shown in Figure 6. Optionally, the fluid line 4.8 may be contained inside the Rigid Shaft 4.7 by a separate lumen within the rigid shaft 4.7 or by allowing fluid to flow through the main shaft lumen. The fluid Line 4.8 allows

fluids, e.g., saline, water, air, etc., to flow from a source of fluid external or internal to a device to the distal end of the end effector or the distal end of a device or cutting device.

[0294] A scraping edge 4.1 may be provided or located on an end effector 4.0 having a rigid shaft 4.7, where the rigid shaft 4.7 and scraping edge 4.1 allow side or axial forces to be applied to the rigid shaft, scraping edge, end effector and/or to a device attached to the end effector to effect scraping or cutting of tissue in a vertebral disc or tissue in another area of the anatomy, while minimizing or preventing deflection or bending of the end effector, shaft or scraping edge. A rigid end effector having a rigid shaft and/or scraping edge may permit or provide effective scraping and/or cutting of a target tissue.

Optionally, a scraping edge may be positioned on the distal end of a flexible, semi-rigid or less rigid shaft or end effector and side forces may be applied to the scraping edge and shaft to effect scraping. In any of the above variations, axial advancement and retraction of the scraping device and/or end effector may result in the scraping or breaking up of tissue, such as vertebral disc tissue. Optionally, one or more scraping edges may be positioned adjacent to the cutting window to position the scraping edge nearly perpendicular to the direction of motion when a curved shaft is used.

[0295] In certain variations, an apparatus for scraping tissue in a subject is provided. The apparatus includes an end effector. The end effector includes a scraping edge positioned on a distal end of the end effector and one or more scraping wings, edges or protrusions positioned at an angle relative to the scraping edge such that the end effector may be actuated in a back and forth motion approximately perpendicular to the scraping edge to scrape or gather tissue, and/or actuated in a back and forth motion approximately perpendicular to the scraping wings to scrape or gather tissue. The scraping wings may serve to collect tissue at the cutting window opening to improve resection.

[0296] In certain variations, the end effector may include a scraping edge positioned on a distal end of the end effector and one or more scraping wings positioned at an angle relative to the scraping edge such that the scraping edge and scraping wings can provide a scraping motion in different directions.

[0297] Fig. 7 shows another variation of an end effector 704 or distal end of a cutting or scraping device. The end effector 704 may include a scraping edge 701, a window 706, a reciprocating cutter 702, and/or a blunt distal tip 705. The reciprocating cutter may be positioned within the end effector. The end effector 704 may include a rigid or flexible shaft 707. The end effector may include one or more wings 708 positioned at an angle to

the scraping edge 701, e.g., such as but not necessarily next to the window 706. The wings 708 may be used to scrape, gather and/or cut tissue.

[0298] Wings 708 may be positioned on the end effector at an angle relative to the scraping edge 701. For example, the wings 708 may be positioned at an angle ranging from 0 to 90 degrees, e.g. at about 90 degrees, relative to the scraping edge 701. The wings 708 are positioned at an angle relative to the scraping edge 701 such that in use, the scraping edge 701 and wings 708 may work or scrape tissue in different directions. The end effector 704 may be used to cut or scrape a variety of tissues in various regions of the body. For example, the end effector may be utilized to cut, scrape and/or gather tissue in a spine or spinal disc, e.g., to perform a discectomy.

[0299] In the variations described herein, the dimensions of the end effectors, shafts, devices, and/or the various components of the end effectors, shafts or devices are merely exemplary in nature and are not intended to be limiting. It is also contemplated that in certain variations, one or more of the various components of the end effectors or the devices, or one or more of the end effectors or the devices may be provided or utilized.

[0300] In certain variations, the various sheaths described herein for guiding a shaft or end effector may be used with a device or end effector having a curved or straight flexible or rigid shaft.

[0301] The cutting devices or scrapers described herein may be utilized to perform a discectomy or other spinal procedures. Additionally, the devices described herein may be utilized or provide methods for resecting, excising and/or removing tissue or soft tissue from various regions in a patient's or subject's body. For example, the devices described herein may be utilized to excise and/or remove or evacuate various tissues or cells including, but not limited to: nasal tissue, for example, nasal polyps; eye tissue; tissue in various gynecological procedures; tumors, e.g., cancerous tumors in the lungs, liver, and in other vital organs; and tissues or cells from other areas in a patient or subject.

[0302] An end effector with a reciprocating or "fixed" Scraper edge 4.1, a Reciprocating Cutter 4.2, and/or a Rigid Shaft 4.7 (as shown in Figure 6) or an end effector of Figure 7 may be useful for excising and/or evacuating various tissues. Such tissues include tissues within the full spectrum of consistency ranging from soft tissues, such as intradiscal nucleus pulposis, to tough tissues, such as End Plate cartilage and ligament, to hard tissues, such as bone. For example, the end effector may be used to prepare the intradiscal space for vertebral fusion procedures where, e.g., it may be desirable to remove the intradiscal nucleus pulposis and End Plate cartilage and scrape the

underlying bone to cause bleeding of the bone to promote healing and fusion between the vertebral bodies and implant.

[0303] In certain variations, an end effector having a Rigid Shaft, a Reciprocating Cutter 4.2, and/or with or without a Scraping Edge, may be useful for excising and/or evacuating tissues in procedures such as a foramenotomy, where it is desirable to decompress an emanating nerve that passes through a stenosed foramen. The end effector having a curved, rigid shaft with or without a Scraping Edge (4.1) may be capable of reaching into the foramen and exposing the Window (4.6) to the inside surface of the foramen such that the reciprocating cutter 4.2 and/or the scraping edge 4.1 may excise tissue. The end effector may be utilized in both “open” and percutaneous surgical procedures.

[0304] Optionally, an end effector or device having a flexible shaft may be used in the tissue excising, scraping or evacuating procedures described above.

[0305] In certain variations, a device may include or a method may utilize a cutter positioned at the distal end of a flexible shaft that has a preformed or predetermined curvature. The shaft may be adapted for insertion into a cannula or sheath where the distal end of the shaft may advance from the cannula (by advancing or retracting the cannula and/or the shaft relative to each other) toward a target site and the shaft may be configured to allow its predetermined curvature to position the distal end of the shaft near the target site, for example, by reverting or beginning to revert to its predetermined curvature upon exiting the cannula or sheath.

[0306] The devices described herein include a mechanism powered by a vacuum source. The devices may be used for applications where a source of vacuum is present. For example, a source of vacuum is frequently available when medical procedures are performed. Many medical devices utilize a reciprocating mechanism to perform their function. The devices described herein may be useful in procedures where evacuation or aspiration is necessary and the device may include evacuation or aspiration features in combination with a vacuum powered reciprocating mechanism.

[0307] In certain variations, a device using an external or internal vacuum source to power a reciprocating mechanism that is connected to a cutter thereby causing the cutter to reciprocate may include a “Y” connection within a handle that connects the vacuum source to both the cutter evacuation tube and the vacuum powered mechanism. As a result, the vacuum performs several functions within the device, such as: powers the mechanism which causes the cutter to reciprocate, draws tissue into a cutting window such

that it may be excised, and/or evacuates the excised tissue to a location external to the device, while maintaining a consistent vacuum pressure even when the vacuum source is shut off to the mechanism during reciprocation.

[0308] In certain variations, a cutting device implements a pneumatic logic or a method utilizes a pneumatic logic to operate a cutting or other reciprocating device whereby a vacuum mechanism valve sequence shuts off the vacuum source from the mechanism to allow a piston to return to its home position without venting the vacuum source to ambient pressure. As a result, the vacuum pressure remains consistent in the cutting and evacuation system portion of the device.

[0309] In certain variations, a method includes maneuvering a flexible shaft around sensitive tissues or structures in the human body by changing the shape of the shaft by extending or retracting an outer sheath on the shaft thereby allowing improved maneuverability of the shaft around structures or within confined spaces. Such a shaft and sheath may be incorporated in any of the devices or vacuum powered devices describe herein.

[0310] In certain variations, a semi-rigid or rigid outer sheath positioned over the flexible curved shaft that is used to change the radius of curvature of the curved shaft may be provided. The radius of curvature of the shaft increases when the straight and rigid sheath is extended over the curved portion of the shaft, whereas the radius of curvature of the shaft returns to its precurved shape when the sheath is retracted from the curved portion of the shaft.

[0311] In certain variations, an electrically resistive, or bipolar or monopolar electrocautery system is included on the distal tip of the shaft that allows the physician to cauterize tissue to control bleeding at the operative site. The electrocautery system may be powered by wires that run the length of the shaft through an internal lumen within the shaft.

[0312] In certain variations, a cutting device utilizing any of the variations of vacuum powered mechanisms described herein results in automatic actuation of a cutter positioned on a flexible or rigid shaft, thereby providing a vacuum powered cutter. The vacuum mechanism for actuating the cutter may enable controls to be utilized for other functions or functions other than operating the mechanism, thereby reducing the number of levers or control buttons on the device. For, example, other controls positioned on the device may be utilized for straightening or curving the shaft or for operating or controlling bipolar systems for cauterizing.

[0313] In one variation, the device may include a handle having a trigger. Actuation of the trigger may cause a cannula or sheath positioned over a flexible shaft extending from the handle to either extend or retract, depending on whether the trigger is pressed or released. The extension or retraction of the cannula may cause the flexible shaft to straighten or curve. The device may include a roller ball, knob or other control mechanism for adjusting or for turning on/off vacuum flow or ambient flow to thereby regulate cutting speed. For example, such a knob or roller ball may be positioned on the cutting device such that the knob or roller ball may be manipulated by a thumb or other finger on the hand holding the handle of the device or on a free hand of the user. Thus, the cutting device can be used with one hand, freeing up the other hand of the user or physician for other uses. A single vacuum line may attach to the device, which both evacuates excised tissue and powers the mechanism. For example, a “Y” connection within the handle of the device may connect the vacuum source to both the cutter evacuation tube and the vacuum powered mechanism, where the device maintains a consistent vacuum pressure or force at the cutting window for evacuating excised tissue during operation of the mechanism.

[0314] The mechanism according to the variations described herein may actuate a cutter automatically by using a mechanism powered by an external vacuum source. The external vacuum source may be connected to the device to provide suction to facilitate tissue cutting and evacuation, therefore, the use of the external vacuum source to power the cutter is completed without requiring an additional power source such as electricity, compressed air, or mechanical input by the operator.

[0315] Because vacuum power is used to actuate the cutter, operator fatigue may be reduced as compared to a system requiring the operator to manually actuate the reciprocating mechanism such as via button or trigger mechanism. Also, the use of vacuum to power the cutter actuation may significantly increase the rate at which the cutter actuates, thereby reducing the time required to complete tissue resection.

[0316] The use of vacuum power to actuate the cutter may allow the control for the rate of actuation to be moved from a “primary” position such as a trigger or button to a “secondary” position on the device handle. As a result, the primary control may be utilized to control the rate at which the cutter mechanism actuates or as a control for the radius of curvature of the shaft, or as a control for an electrocautery system.

[0317] A knob, trigger, roller clamp, or other control interfaces may be used to control the rate at which the vacuum mechanism reciprocates. These options allow the device to

be designed in a variety of configurations to suit various surgical specialties or personal preferences.

[0318] The various pneumatic logic sequences utilized by the systems described herein may optionally maintain high vacuum throughout the engine cycle by never venting the vacuum source to the atmosphere. As a result, the vacuum pressure that facilitates cutting and evacuation may not decrease while the mechanism reciprocates.

[0319] A single tube from the vacuum source to the device to serve the functions of tissue cutting, evacuation and to power the mechanism which actuates the reciprocating cutter may be utilized. The single tube from the vacuum source simplifies connections required for device operation and reduces the number of tubes attached to the device thereby reducing the “clutter” and unwieldiness caused by multiple tubes and wire connections to the device.

[0320] In certain variations, a second source of vacuum may be provided such that separate vacuum sources power the mechanism and provide suction to the distal end of the cutting device or end effector for excising and/or evacuating tissue. In certain variations, one or more vacuum sources and/or one or more tubes or conduits connecting a vacuum source to a device to supply suction to the device and/or to power the device may be utilized or provided.

[0321] A cannula may be used on the flexible shaft to change the radius of curvature on the shaft in a range from nearly straight to curved in an arc of 180 degrees. This allows the operator to optimize the curvature of the shaft based on the patient anatomy. The operator can increase or decrease the force between the shaft and the target tissue being excised by extending or retracting the cannula to increase or decrease the natural radius of curvature of the shaft.

[0322] Optionally, an electrically resistive, or monopolar or bipolar cautery may be used on the distal tip of the devices described herein to allow the operator to cauterize tissue to control bleeding at the site where tissue has been excised. This feature obviates the need to remove the device from the operative site to replace it with an electrocautery device. This improves speed and ease-of-use for the operator while reducing blood loss for the patient.

[0323] The devices described herein may be manufactured using low cost components and assembly techniques; as a result, the cost of the device is much lower than a similar device which utilizes an electric motor.



[0324] The devices described herein may have a relatively low mass and may be easily sterilized using commonly used sterilization techniques such as, e.g., electron beam radiation, gamma radiation, or Ethylene Oxide gas.

[0325] Other variations of vacuum powered devices and methods are provided below. For example, a medical device may utilize a mechanism powered by an external source of vacuum to perform one or more function(s) through reciprocating motion output by the mechanism. The device may excise and evacuate tissue. The device may have a single attachment to an external vacuum source wherein said vacuum provides power to the mechanism and assists in excising tissue. The device may have a single attachment to an external vacuum source wherein said vacuum provides power to the mechanism and assists in evacuating tissue. The device may utilize a mechanism that does not utilize inertia of mass to transition past valves to change state. The device may not vent the external vacuum source to ambient air at any time during its cycle thereby causing a drop in vacuum within the device. The device may include a flexible shaft that has a preformed curvature on the distal portion and a straight rigid or semi-rigid cannula around the outer diameter of the shaft; the radius of curvature of the shaft may be changed by sliding the cannula over the distal curvature whereby the radius of curvature is increased when the cannula is extended over the distal curvature and the distal curvature returns to its' preformed curvature when the cannula is retracted from the distal curvature. The device may include a monopolar electrode or bipolar electrodes on or near the distal extremity. The device may have a single connection to an external vacuum source that powers a vacuum powered mechanism and evacuates excised tissue. The single connection to an external vacuum source may also use vacuum to draw tissue into a cutting window to present tissue for the purpose of excising said tissue.

[0326] A medical device may include a mechanism powered by an external vacuum source wherein said mechanism is comprised of a piston that is set into motion by creating differential pressure on either side of the piston wherein one side of the piston has ambient air and the air on the other side of the piston is at least partially evacuated. The mechanism may include a valve component that opens the volume next to the Piston alternately to ambient air or vacuum. The valve component may be actuated as a result of translation of the Piston wherein the Piston acts upon the valve to cause it to open or close the fluid connections to ambient air or to the external vacuum source.

[0327] A method for causing a reciprocating mechanism powered by vacuum to transition past valves to change states wherein an adequate volume of air has been

evacuated prior to closing the valve to the external vacuum source such that the mechanism continues to move into the evacuated volume such that the valve fully transitions to open the source of vacuum to a different volume may also be provided.

[0328] The method may include the following logic sequence: Vacuum open to the distal side of the Cylinder, ambient is closed to distal; ambient open to proximal side of Cylinder, vacuum is closed to proximal; Piston advances toward distal position due to the vacuum inside the distal side of the cylinder and ambient pressure on the proximal side of the Piston; Piston contacts Shuttle and advances it toward the distal position; Vacuum Seal on Shuttle moves from proximal side of Vacuum Port to the distal side of the Vacuum Port while the Distal Seal on the Shuttle opens the ambient air to vent the distal side of the Cylinder to ambient pressure and the Proximal Seal on the Shuttle closes the ambient air vent to the proximal side of the Cylinder; Piston reverses direction and moves in the proximal direction due to the vacuum inside the Cylinder proximal to the Piston and ambient air on the distal side of the Piston; Piston contacts Shuttle and advances toward the proximal position; Vacuum Seal on Shuttle moves from distal side of Vacuum Port to the proximal side of the Vacuum Port while the Proximal Seal on the Shuttle opens the ambient air to vent the proximal end of the Cylinder to ambient pressure and the Distal Seal on the Shuttle closes the ambient air vent to the Distal side of the Cylinder. The above steps may repeat unless the vacuum source is disconnected, turned off, or if the vacuum is inadequate to overcome the force required to move the Piston.

[0329] Optionally, the method may include the following logic sequence: Vacuum open to the distal side of the Cylinder, ambient is closed to distal; ambient open to proximal side of Cylinder; Piston advances toward distal position due to the vacuum inside the distal side of the cylinder and ambient pressure on the proximal side of the Piston; Piston contacts Shuttle and advances it toward the distal position; Vacuum Seal on Shuttle shuts off vacuum to the distal side of the Piston and continues to move distally thereby opening the ambient air supply to the distal side of the Piston; Return Spring motivates the Piston in the proximal direction due to the equalization of air pressure on both sides of the Piston; Piston Shaft contacts Shuttle and motivates it in the proximal direction; Shuttle Seal on the Shuttle shuts off ambient air supply to the distal side of the Piston and opens the vacuum to the distal side of the Piston. The above steps may repeat unless the vacuum source is disconnected, turned off, or if the vacuum is inadequate to overcome the force required to move the Piston.

[0330] In another variation, a medical device includes a reciprocating cutting blade such as is used to excise and evacuate tissue that uses a reciprocating mechanism powered by an external vacuum source that may be used for medical procedures where a source of vacuum is present.

[0331] In certain variations, any of the mechanisms described herein may include a drive shaft or drive piston located in a chamber. The suction may be applied to both sides of a drive shaft or drive piston in an alternating manner to cause the drive shaft or drive piston to reciprocate between a drive stroke and a return stroke to create a reciprocating motion. The mechanism may include a shuttle body or valve coupled to the drive shaft by a linkage or linkage mechanism. The shuttle body or valve may be moveable between a forward and return position, where movement between the forward and return positions alternates a fluid path between the chamber and vacuum source so that during application of suction or vacuum from the vacuum source movement of the shuttle body or valve causes the drive shaft to cycle between the drive stroke and the return stroke.

[0332] The linkage may couple the drive shaft to the shuttle body or valve such that as the drive shaft approaches the end of the drive or return stroke the linkage transfers a force to the shuttle body or valve to assist in switching between the forward and return positions and prevents or minimizes unstable flutter of the shuttle body or valve between the forward and return positions.

[0333] Deformable Linkage

[0334] In certain variations of the mechanisms or devices described herein, a linkage or bi-stable switch may be manufactured using various materials that strain when the bi-stable switch is exposed to forces from the switch spring coupled thereto. For example, the linkage or switch may be made from plastic or other materials having similar properties. The linkage or bi-stable switch may be configured to deform when in an unsupported state. The bi-stable switch may be positioned within the chamber or handle of the device for storage and shipment such that features or support elements within the chamber or handle engage the switch and assume the stress from the switch spring or biasing component, thereby relieving the stress from the bi-stable switch. The device may be configured such that after use, the bi-stable switch stops in a position where the bi-stable switch is not engaged with the support elements and not relieved of stress from the switch spring. As a result, the bi-stable switch is exposed to strain or stress from the switch spring or biasing component, which causes the linkage or switch to deform to a

degree that the bi-stable switch no longer functions at some period of time after it is used. The deformed bi-stable switch may prevent re-use of the device, e.g., such that the device is suitable for single use.

**[0335]** In certain variations, a medical device having a vacuum powered mechanism as described herein may include support elements or features for supporting a linkage or bi-stable switch of the mechanism. Figures 13A-13B show an example of a medical device including a linkage or bi-stable switch 720 coupled to a drive piston or drive shaft 721 and shuttle body or valve 722 of a mechanism and positioned in a chamber or handle 725 of a cutting device. The chamber or handle 725 of the medical device includes a posterior support rib 726. The Posterior support rib 726 may be located inside the chamber or handle 725 of the device and the posterior support rib 726 may support the posterior arm 727 of the linkage or Switch component 720 while the device is in storage or during shipment, prior to use. The posterior support rib 726 prevents the posterior arm 727 of the linkage or Switch component 720 from deforming as a result of plastic creep due to stress from the Switch Extension Spring 723 on the linkage or switch 720.

**[0336]** The chamber or handle 725 of the medical device may also include an Anterior Support Rib 728. The anterior support rib 728 may support the anterior arm 729 of the linkage or Switch component 720 while in storage or shipment, prior to use. The anterior support rib 728 prevents the anterior arm 729 of the linkage or switch component 720 from deforming as a result of plastic creep due to stress from the Switch Extension Spring 723 on the linkage 720.

**[0337]** Figures 13C and 13D are zoomed in cross sectional views showing the linkage or bi-stable switch 720 coupled to a drive piston or drive shaft and shuttle body (not shown) of a mechanism and positioned in a chamber or handle of a cutting device. The mechanism includes a Drive Piston Chamber 730 which is a cavity or lumen within the mechanism wherein the Drive Piston reciprocates. An End Cap 731 is assembled to the ends of the mechanism body (732) to enclose the Drive Piston Chamber (730). The mechanism body 732 encloses the Drive Piston Chamber (730) and serves as an attachment point for the linkage or Switch component 720.

**[0338]** Figure 13C, shows the Posterior Arm 727 of the linkage or Switch 720 as it is supported by the Posterior Support Rib (726) while in storage or during shipment. Figure 13C shows the Anterior Arm 729 of the linkage or Switch 720 as it is supported by the Anterior Support Rib (728) while in storage or shipment.

[0339] Figure 13D shows the posterior arm 727 unsupported and subject to plastic creep and deformation as a result of stress from the Switch Extension Spring (not shown). Figure 13D shows the anterior arm 729 unsupported and subject to plastic creep and deformation as a result of stress from the Switch Extension Spring (not shown). In figure 13D, the switch 720 is in a stopped position after use of the device.

[0340] The linkage or switch may include a Switch Component Hinge 733. The switch component hinge 733 is a flexible portion of the Switch Component 720 that allows the Anterior Arm 729 of the Switch and the Posterior Arm 727 of the Switch to change positions between the positions shown in figures 13C and 13D.

[0341] In certain variations, the linkage or switch may include a protrusion or notch to engage the ribs or features of the device such that the ribs or features provide support to the switch in a stored or pre-use state. After use, the switch may be stopped in a position where the switch is disengaged from the ribs or features, such that the force imparted by the spring switch on the spring causes deformation of the switch. After use, the cutter may be stopped in an open or proximal position, and the switch may be disengaged from the ribs or support features.

[0342] In certain variations, the linkage or bi-stable switch may be made from a copolymer or other material. The flex modulus of the copolymer or material of the switch or linkage may vary, e.g., in certain variations it may have a flex modulus in the range of about 150,000 to about 210,000. Various materials having higher or lower flex modulus may be used to create stronger or weaker switches. Depending on the strength of the switch, the device may be operable for single use or multiple uses. For example, the device may be operable for 1-2 days after initial use for a weaker switch or for 3-5 days to months after initial use for a stronger switch. The switch may no longer function after some time after its initial use. The deformable linkage or switch arrangement described herein may be utilized with a vacuum powered mechanism (e.g., such as the mechanisms described herein) which may be used to operate various medical devices and to actuate an operable element of a medical device. A method of preventing reuse or for providing a certain number of use of a vacuum powered device described herein may include providing a deformable linkage or switch which deforms in an unsupported or strained position to render the mechanism inoperable.

[0343] Malleable Elongate Shaft Variation

[0344] In certain variations of the various cutting devices described herein, the evacuation shaft located proximal to the Cutter and positioned in the elongate shaft and/or outer malleable shaft may have a variable diameter to improve tissue resection. For example, the diameter may be optimized to increase evacuation and resection rates. The diameter may be optimized to prevent kinking or collapsing when the evacuation shaft is curved. The diameter may be optimized to prevent increased friction between the evacuation shaft and a lumen of the elongate shaft or outer malleable shaft, which lumens may decrease in diameter upon bending. The diameter of the evacuation shaft may be smaller in sections that may be bent or curved or are located in portions of the elongate shaft or outer malleable shaft that are bent or curved. The diameter of the evacuation shaft may be larger in sections that are located in portions of the elongate shaft or outer malleable shaft that are not bent or that remain straight, where a larger diameter may help improve the tissue evacuation rate and/or tissue resection rate. Optionally, the evacuation shaft or lumen may have a constant diameter having the same size throughout the shaft to improve resection and/or evacuation rates.

[0345] Figures 14A-14F show various views of a variation of an elongate shaft 809 for use with any of the cutting devices described herein. The elongate shaft 809 includes a cutting window (810) near the distal extremity of the elongate shaft 809. The elongate shaft 809 may also include an outer malleable shaft or Metal Shaft (820), Outer Sheath (817), Cutter (818), Evacuation Shaft (821) and irrigant lumen 814.

[0346] The Cutting Window 810 includes an opening in the elongate Shaft (809) that fluidly communicates with the external source of suction via the Evacuation Lumen (815) of evacuation shaft 821. Suction applied from an external suction source draws tissue and fluids into the Cutting Window (810) where it may be excised by the Cutter (818) and/or evacuated through the Evacuation Lumen (815).

[0347] The elongate shaft may extend from or be coupled to a Device Body 811. The Device body 811 serves as housing for the mechanism, irrigant conduit, and Evacuation Lumen, and may also serve as a handle for the operator of the device. A Trigger 812 is provided on the device body 811. The trigger 812 may be actuated by the operator to Start/Stop actuation of the device and the Cutter 818. An external suction port 813 may extend from the device body 811 and serves as a connection port to a source of external suction.

[0348] The Outer Sheath 817 may be flexible and may provide a covering around or on the outer malleable shaft or Metal Shaft (820) and encloses openings in the Metal Shaft

(820) such as the Bending Slits (819). The metal shaft 820 is a malleable shaft that provides structure to the elongate Shaft (809). For example, the metal shaft 820 may be a stainless steel annealed shaft. Bending Slits 819 may be cut into the Metal Shaft (820) to enable the elongate Shaft (809) to be bent, twisted, manipulated or shaped such that the shaft can be moved into a variety of configuration to access an anatomy of a patient and to reach various anatomical locations within the patient. The Outer Sheath 817 may include one or more lumens (e.g., dual lumens). A lumen may hold the outer malleable shaft or metal shaft 820. The Outer sheath 817 may also include an irrigant Lumen (814). The figures depict a transparent Outer Sheath, e.g., made from PEBAX, but other materials, e.g., flexible materials, may be utilized and/or the outer sheath may not be transparent.

**[0349]** An irrigant lumen 814 may run through the Outer Sheath (817). The irrigant lumen 814 provides fluid communication between a source of irrigant and the Irrigant Port (816). The Irrigant Port 816 serves as an opening in the Metal Shaft (820) that allows irrigant to fluidly communicate between the Irrigant Lumen (814) and the Evacuation Lumen (815) and/or to the site of cutting. In an alternative variation, irrigant may be allowed to flow in the space between the Evacuation Shaft (821) and the Metal Shaft (820), to the evacuation lumen and/or the site of cutting.

**[0350]** An Evacuation Shaft 821 may be a flexible component positioned within the outer malleable shaft or Metal Shaft (820). The Evacuation shaft 821 may be connected to the Cutter (818) at its distal extremity. The evacuation shaft 821 reciprocates from the motion of the vacuum powered mechanism and causes the Cutter (818) to reciprocate past the Cutting Window (810) to excise tissue that enters the Cutting Window (810). The Cutter (818) has a sharpened distal edge to cut tissue that is drawn into the Cutting Window (810). The lumen within the Evacuation Shaft (821) is the Evacuation Lumen (815). The Evacuation Lumen (815) may provide fluid communication between the Cutting Window (810) and an external source of suction.

**[0351]** The evacuation shaft may optionally have a variable diameter or bumped lumen as described above, where the diameter of the evacuation shaft and/or lumen is increased or larger in sections where curving of the evacuation shaft is not performed or is less necessary and the diameter of the evacuation shaft and/or lumen is decreased or smaller in sections where curving or bending is performed or is necessary, to optimize or increase the rate of tissue evacuation and/or the resection rate. Optionally, the evacuation shaft or lumen may have a constant diameter having the same size throughout the shaft. In certain variations, the elongate shaft may be rotatable relative to the handle or chamber to

which the elongate shaft is coupled. The handle or chamber may include features for limiting the degree of rotation of the elongate shaft. For example, the degree of rotation may be limited to ninety degrees in either direction or one hundred and eighty degrees.

**[0352]**     Filter mechanism

**[0353]**     In any of the various medical devices described herein, a filter mechanism may be utilized for collecting or filtering resected or cut tissue.

**[0354]**     In certain variations, a filter mechanism may include a filter body and a filter lid. The filter body may include one or more tissue collection chambers, a bypass chamber and an exit port that serves as a connection point for the external source of suction. The filter lid may have two attachment points or ports for connecting tubing or a conduit. One attachment or port is located in a position such that fluid continuously flows through the filter lid and the filter body bypass chamber regardless of a filter lid (switch) position. This may be useful for connecting a section of tubing or conduit to perform a function that does not need the fluid medium to be filtered such as a connection to a vacuum powered motor or mechanism.

**[0355]**     The other attachment port may be located in a position such that it can be moved over a bypass chamber or a collection chamber. The filter lid may be moved relative to the filter body to position tubing or conduit carrying excised tissue to any of the chambers in the filter body. When the tubing port carrying the excised tissue is positioned over the bypass chamber, the tissue and fluid medium flow through the bypass chamber and exit the device through the suction connection port.

**[0356]**     When the tubing port carrying excised tissue is positioned over one of the collection chambers, the fluid medium passes through the filter and into the bypass chamber and then exits the device through the suction connection port. The tissue remains in the collection chamber where it may be collected for subsequent analysis.

**[0357]**     Upon completion of the procedure, the filter mechanism, including the filter lid and filter body may be removed from the device. The tubing connections can be separated from the filter lid and render the device inoperable by making reassembly (and consequently, re-use) prohibitively difficult.

**[0358]**     Optionally, the filter mechanism may be filled with tissue preservative, e.g., such as formalin, either by removing the filter lid from the body component, or by injecting the preservative through an opening in the filter mechanism. Plugs may be



placed in the tubing ports in the filter lid and in the exit port to prevent the tissue preservative from leaking out of the filter mechanism.

[0359] The filter lid or other portion of the filter body may have features to store the plugs until they are ready for use. The filter lid may be removed from the filter body to expose a plurality of chambers to extract tissue from the tissue filter chamber for analysis.

[0360] The filter mechanism may have provisions to label the contents of the tissue collection chambers with information such as patient name, date of collection, and the anatomical location that was sampled or type of tissue.

[0361] The tissue filter mechanism may be removed from a tissue resection device and used as a container to send tissue samples to a laboratory for analysis.

[0362] The filter mechanism may be integrated in or coupled to a vacuum or suction powered medical device or tissue resection or cutting device, such as the devices described herein. The filter mechanism may also be integrated in or coupled to other medical devices, such as cutting or resecting devices, which are powered by electrical, pneumatic or other power sources.

[0363] Figures 15A-15F show one variation of a filter mechanism integrated into a microdebrider or tissue cutting or resection device 913. The Filter Mechanism (912) may include two primary components; Filter Lid (907) and Filter Body (901).

[0364] The filter mechanism 912 includes a filter body 901. The filter body 901 may include at least one tissue collection chamber (902), a bypass chamber (903), a suction connection port (904) and a filter or filter slits 906. The filter body 901 may include markings (905) to help identify the contents of the tissue collection chambers.

[0365] Tissue and/or fluid conduction medium may flow into the tissue collection chamber 902. The tissue may be stopped by the filter slits 906 while the fluid conduction medium is able to flow into the bypass chamber 903 where it exits the device through the suction connection port 904. Tissue collects in the tissue collection chamber 902 where it may be subsequently removed for analysis.

[0366] Tissue and fluid that flow into the bypass chamber 903 flow unabated through the suction connection port (904). Fluid may flow into the bypass chamber 903 directly or from the tissue collection chamber 902 through the filter slits (906).

[0367] The Suction Connection Port (904) serves as the connection point for the filter to the source of suction or vacuum. Tissue and/or fluid passes through the Suction Connection Port 904 toward the suction source from the Bypass Chamber (903).

[0368] A filter or Filter Slits (906) separate the tissue collection chamber (902) from the bypass chamber (903) and serve to prevent the passage of tissue from the filter collection chamber (902) into the bypass chamber (903) while allowing fluid to pass.

[0369] The filter mechanism includes a Filter Lid (907) which provides a fluid-tight cover for the Filter Body (901) to contain fluid and/or tissue within the Filter Body (901). The Filter lid includes one or more ports or openings. The Filter Lid 907 may have a Motor Supply Opening (908), a Tissue Evacuation Opening (909), one or more, e.g., two, Dual Plug Retention Features (910), and a Suction Connection Plug Retention Feature (910). The Filter Lid (907) may be rotatable relative to the Filter Body (901) to position a tissue evacuation port or opening 909 adjacent to either the bypass chamber (903) or the tissue collection chamber (902). A Filter Lid Control Tab (914) may be used as a control surface for the operator or other mechanism to rotate the Filter Lid 907 relative to the Filter Body 901.

[0370] The Motor Supply Opening (908) serves as an opening through the Filter Lid (907) between the Bypass Chamber (903) and a conduit that communicates with the vacuum or suction powered motor or mechanism of a device. The motor supply opening 908 is located at or near the center of the Filter Lid (907), therefore, the position of the Motor Supply Opening 908 does not change relative to the Bypass Chamber (903), even when the lid is rotated. As a result, the air flowing from the vacuum or suction powered motor does not flow through a filter, rather, the air always freely flows through the Bypass Chamber (903) and exits the device through the Suction Supply Port (904).

[0371] The Tissue Evacuation Opening (909) is an opening through the Filter Lid (907) which serves as a connection port between a conduit that fluidly communicates with the distal cutting mechanism to evacuate tissue and the filter body chambers. The Tissue Evacuation Opening (909) moves relative to the Filter Body (901) as the Filter Lid (907) is rotated by the operator thereby positioning the Tissue Evacuation Opening 909 over either a Tissue Collection Chamber (902) or a Bypass Chamber (903).

[0372] The filter lid 907 may include one or more filter Plug Retention Features (910) which serve to retain one or more Filter Plugs (911) until ready for use to plug the openings in the Filter Mechanism (912) or filter lid 907, once the filter mechanism is removed from the device.

[0373] Filter Lid Plug (911) may be used to close openings in the Filter Mechanism (912) or filter lid 907 to provide a fluid tight seal.

[0374] In certain variations, the microdebrider or resection device 913 may be powered by a vacuum source or source of suction as described herein. In certain variations, the microdebrider or resection device may be powered solely by a vacuum source or source of suction without the need for another power source.

[0375] In certain variations, a microdebrider or cutting device may include an integrated tissue filter mechanism wherein the removal of the filter mechanism disables the device and renders re-assembly of the device to be prohibitively difficult and thereby preventing re-use of the device.

[0376] In certain variations, a microdebrider or cutting device may include an integrated tissue filter mechanism wherein a single source of suction is connected to the microdebrider or cutting device and two conduits are connected to the tissue filter mechanism, where one conduit communicates with a motor or mechanism that is powered by a source of suction or vacuum and the second conduit communicates with a cutting mechanism for the purpose of evacuating excised tissue.

[0377] The contents of US patent application having the attorney docket number LRMD-N-Z014.00-US and filed on January 4, 2013 and U.S. Patent Application No. 61,597,642 are hereby incorporated by reference in their entirety. In certain variations, any of the filter mechanisms and/or other features described herein may be incorporated in or utilized with any of the devices or methods described herein or in the patent applications referenced herein.

[0378] The above arrangements, materials, and dimensions for the vacuum powered mechanisms described herein are exemplary and are not intended to be limiting.

[0379] Each of the individual variations described and illustrated herein has discrete components and features which may be readily separated from or combined with the features of any of the other variations. Modifications may be made to adapt a particular situation, material, composition of matter, process, process act(s) or step(s) to the objective(s), spirit or scope of the present invention.

[0380] Methods recited herein may be carried out in any order of the recited events which is logically possible, as well as the recited order of events. Furthermore, where a range of values is provided, every intervening value between the upper and lower limit of that range and any other stated or intervening value in that stated range is encompassed within the invention. Also, any optional feature of the inventive variations described may be set forth and claimed independently, or in combination with any one or more of the features described herein.

[0381] All existing subject matter mentioned herein (e.g., publications, patents, patent applications and hardware) is incorporated by reference herein in its entirety except insofar as the subject matter may conflict with that of the present invention (in which case what is present herein shall prevail). The referenced items are provided solely for their disclosure prior to the filing date of the present application. Nothing herein is to be construed as an admission that the present invention is not entitled to antedate such material by virtue of prior invention.

[0382] Reference to a singular item, includes the possibility that there are plural of the same items present. More specifically, as used herein and in the appended claims, the singular forms “a,” “an,” “said” and “the” include plural referents unless the context clearly dictates otherwise. It is further noted that the claims may be drafted to exclude any optional element. As such, this statement is intended to serve as antecedent basis for use of such exclusive terminology as “solely,” “only” and the like in connection with the recitation of claim elements, or use of a “negative” limitation. Unless defined otherwise, all technical and scientific terms used herein have the same meaning as commonly understood by one of ordinary skill in the art to which this invention belongs.

[0383] This disclosure is not intended to be limited to the scope of the particular forms set forth, but is intended to cover alternatives, modifications, and equivalents of the variations described herein. Further, the scope of the disclosure fully encompasses other variations that may become obvious to those skilled in the art in view of this disclosure. The scope of the present invention is limited only by the appended claims.

CLAIMS:

1. A medical device driven by a vacuum source, the device comprising:
  - a working end having an operable element, the operable element coupled to a mechanism comprising a drive piston, a valve, and a biasing component, such that when the mechanism is driven by the vacuum source, movement of a drive piston actuates the operable element;
  - wherein the drive piston is located in a chamber and is moveable within the chamber between a drive stroke and a return stroke;
  - wherein the valve is configured to alternately seal and vent a cross-hole in the drive piston, the cross-hole when vented allowing airflow across the drive piston and into at least a portion of the chamber; and
  - wherein the biasing component is positioned against the drive piston, wherein alternately sealing and venting the cross-hole in the drive piston causes the drive piston to cycle between the drive stroke and the return stroke.
2. The device of claim 1, wherein the operable element comprises a motion selected from the group consisting of rotary motion, linear motion, and reciprocating motion.
3. The device of claim 1 or 2, wherein the drive piston comprises a drive shaft, wherein the drive shaft has a lumen capable of being fluidly coupled to the vacuum source to supply vacuum or suction to the chamber to evacuate the chamber.
4. The device of claim 3, wherein the operable element comprises a cutter and wherein the drive shaft is coupled to the cutter, such that reciprocation of the drive shaft causes reciprocation of the cutter.
5. The device of claim 1 or 2, wherein the drive piston comprises a drive shaft and an evacuation shaft is coupled to the drive shaft, wherein the evacuation shaft is configured such that vacuum or suction can pull debris or tissue through an evacuation lumen of the evacuation shaft.

6. The device of claim 5, wherein a cutter is coupled to a distal end of the evacuation shaft such that reciprocation of the drive shaft causes reciprocation of the evacuation shaft and the cutter.
7. The device of any one of the preceding claims, where the working end comprises an elongate shaft wherein the elongate shaft has a lumen capable of being fluidly coupled to a supply of an irrigant, wherein the irrigant does not flow through the lumen unless vacuum from the vacuum source draws the irrigant through the lumen.
8. The device of any one of the preceding claims, further comprising a handle coupled to the working end.
9. The device of claim 8, where the mechanism is located in the handle.
10. The device of any one of the preceding claims, wherein the working end comprises a malleable shaft portion, wherein the operable element is reciprocated within the malleable shaft portion.
11. The device of any one of the preceding claims, where the working end further comprises an electrocautery element positioned at a distal end of the working end.
12. The device of any one of the preceding claims, further comprising a scraping edge at the working end.
13. The device of claim 1, where the drive piston is coupled to an evacuation shaft and the evacuation shaft is moveable in a rotating motion.
14. The device of claim 1, where the drive piston is coupled to an evacuation shaft and the evacuation shaft is moveable in a linear motion.
15. The device of any one of the preceding claims, wherein the mechanism is powered solely by suction created by vacuum source.

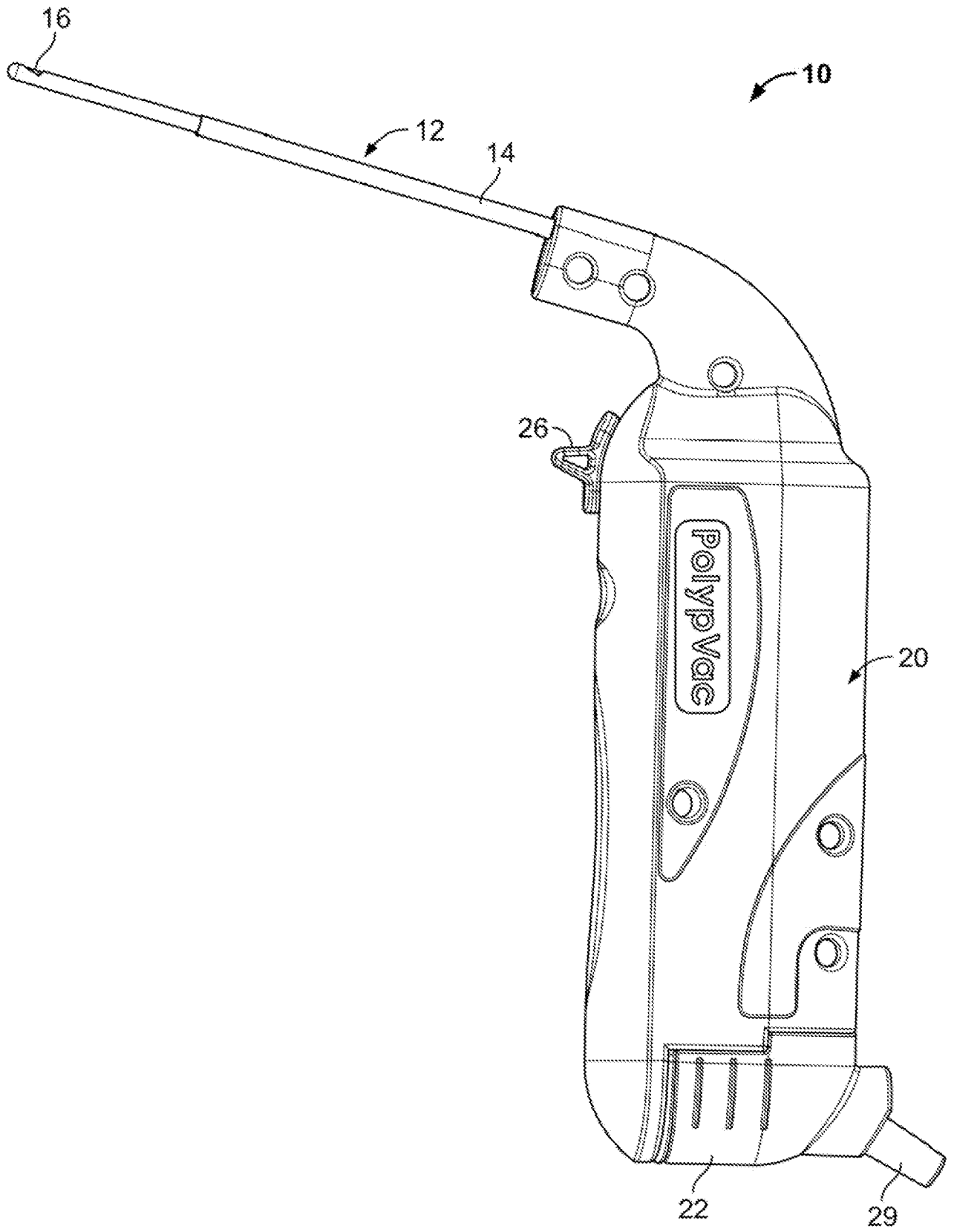

FIG. 1A

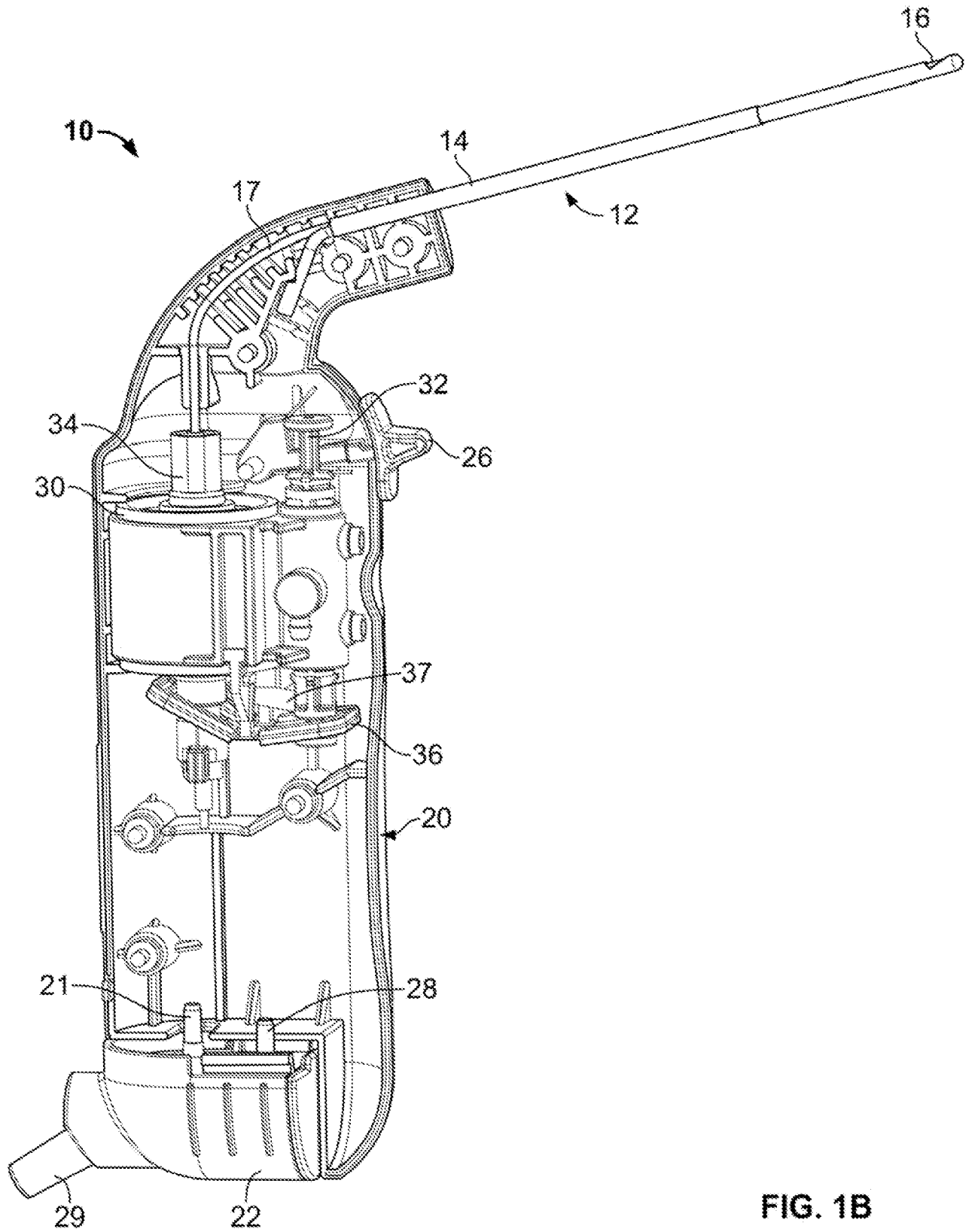

FIG. 1B



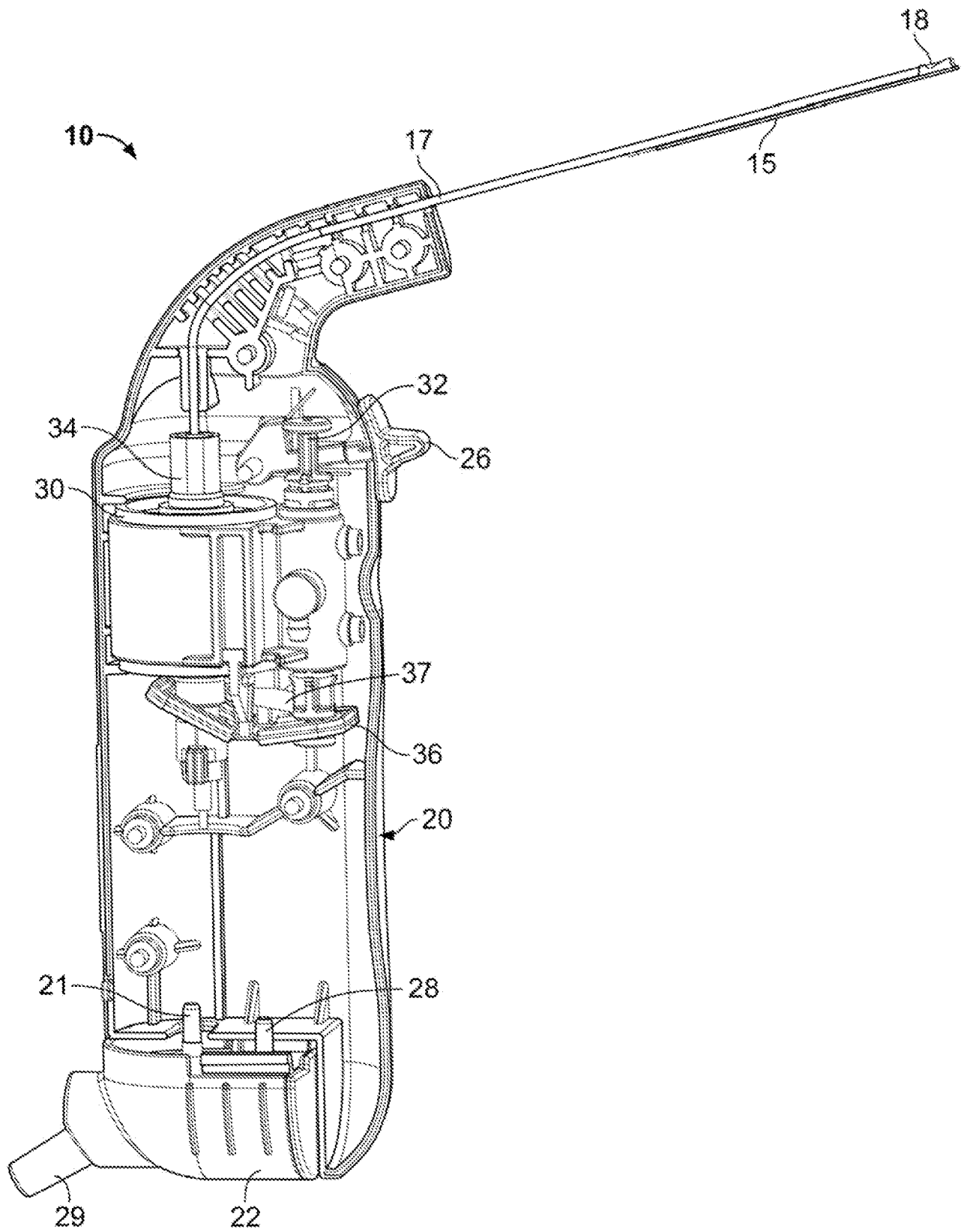

FIG. 1C

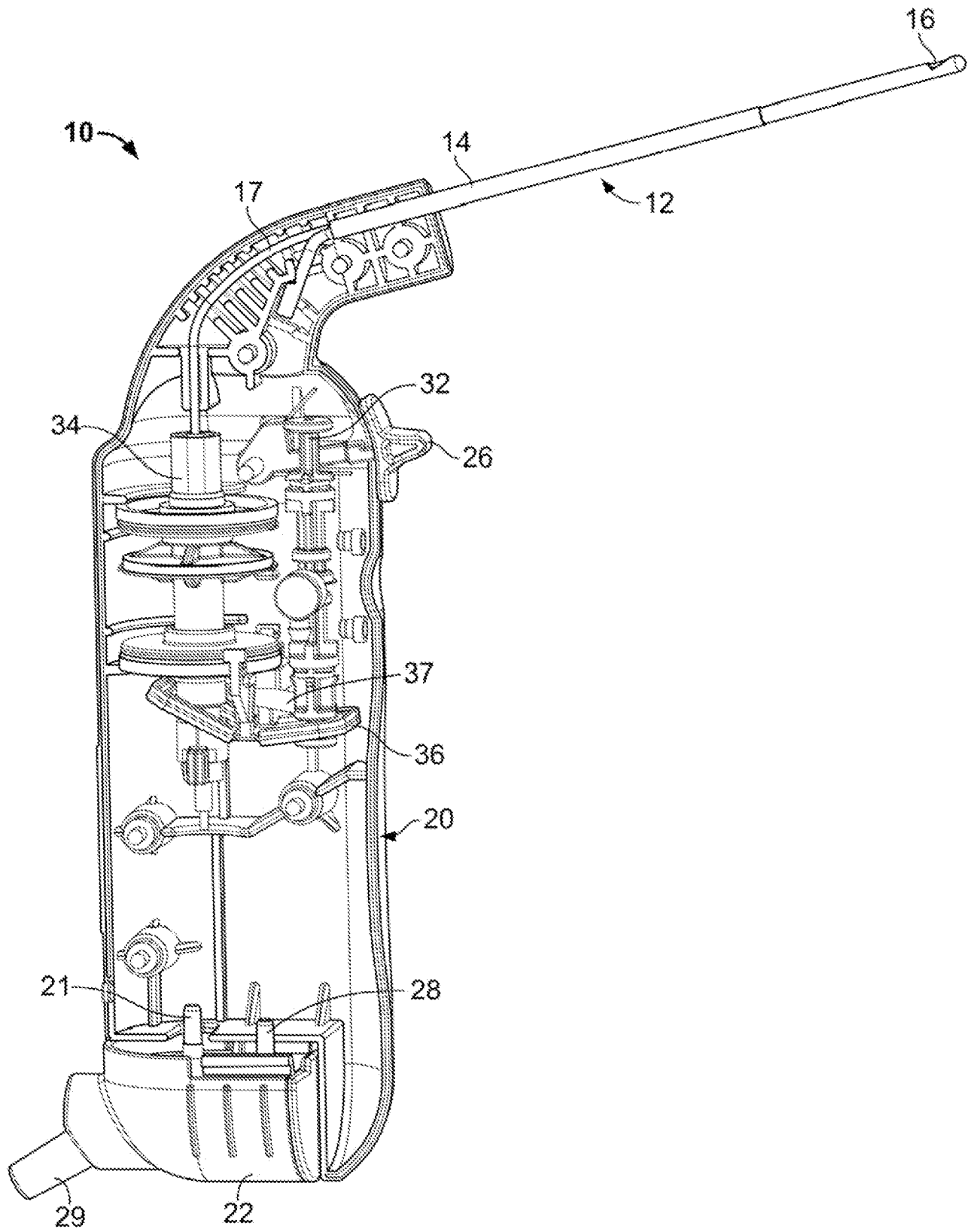

FIG. 1D

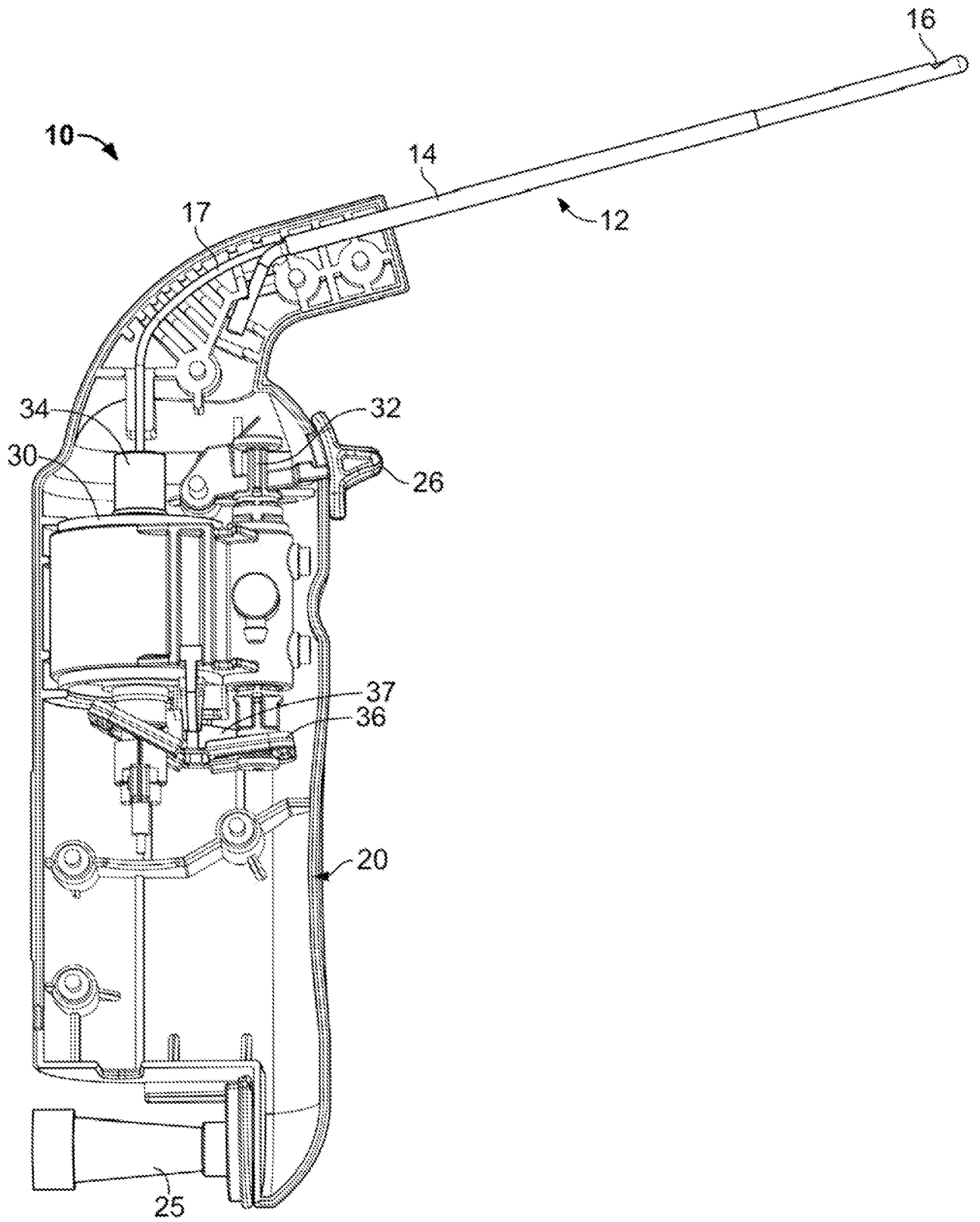

FIG. 1E

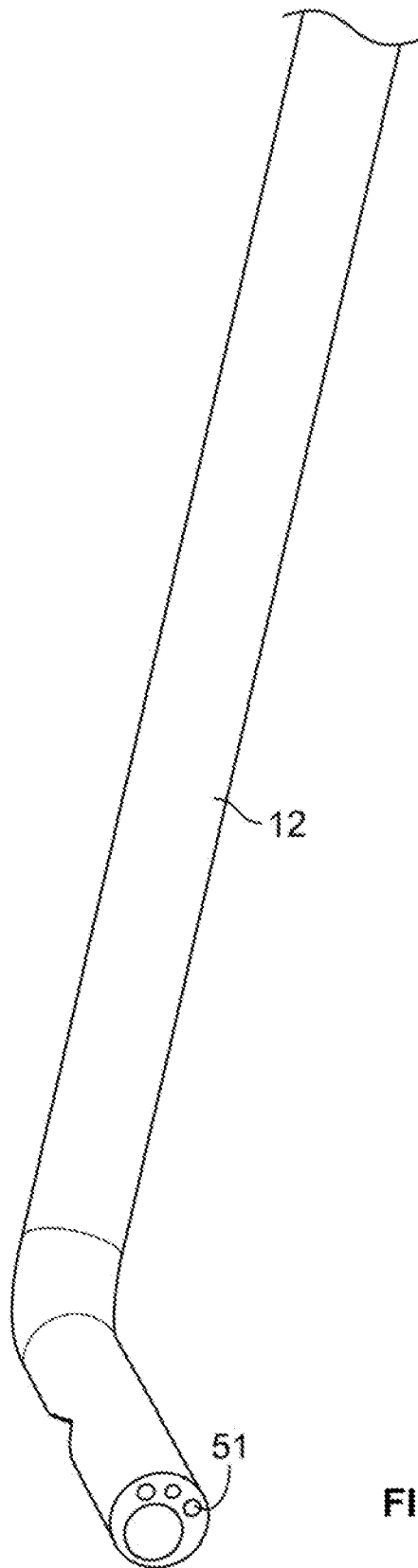

FIG. 1F

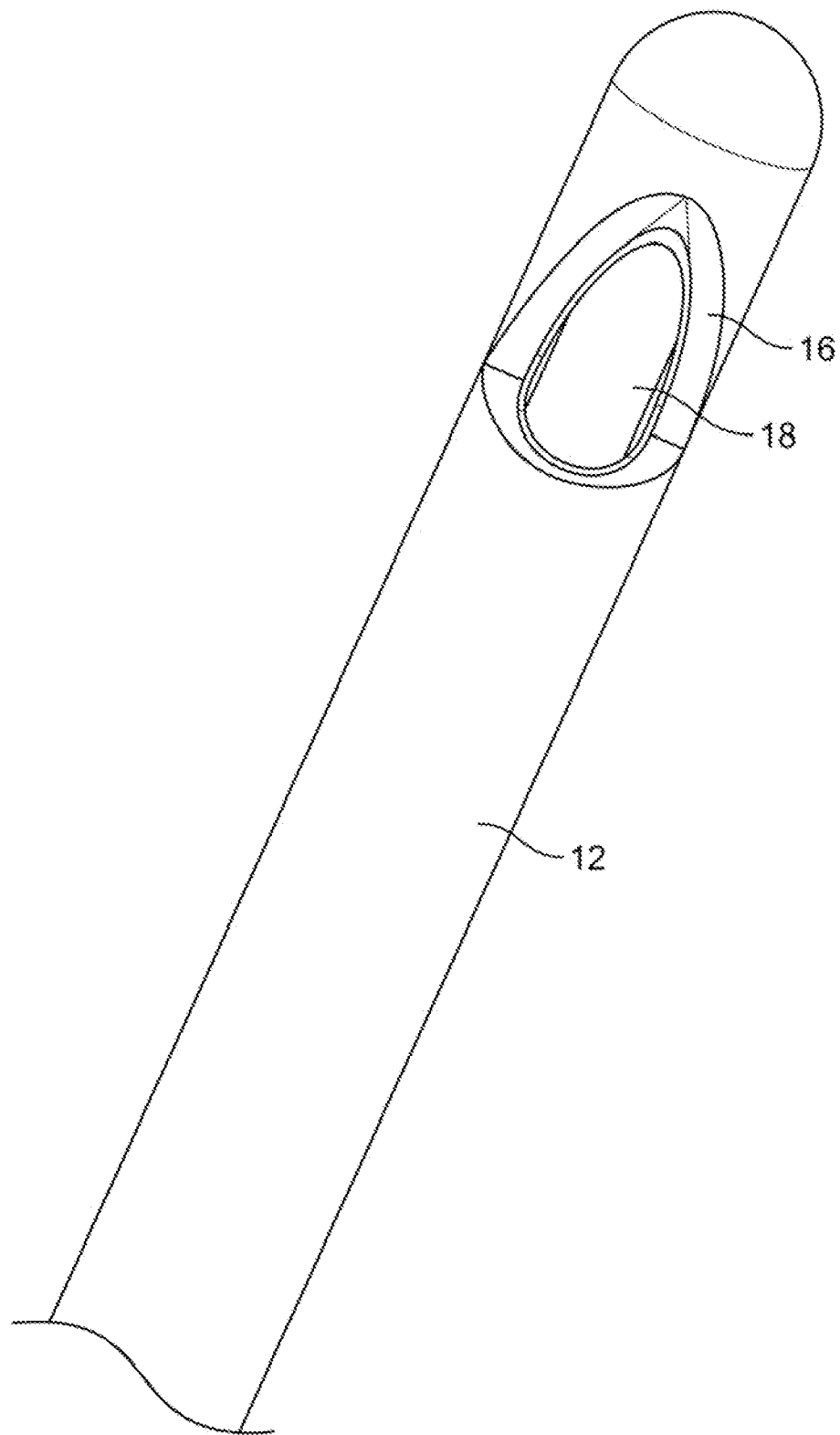

FIG. 1G

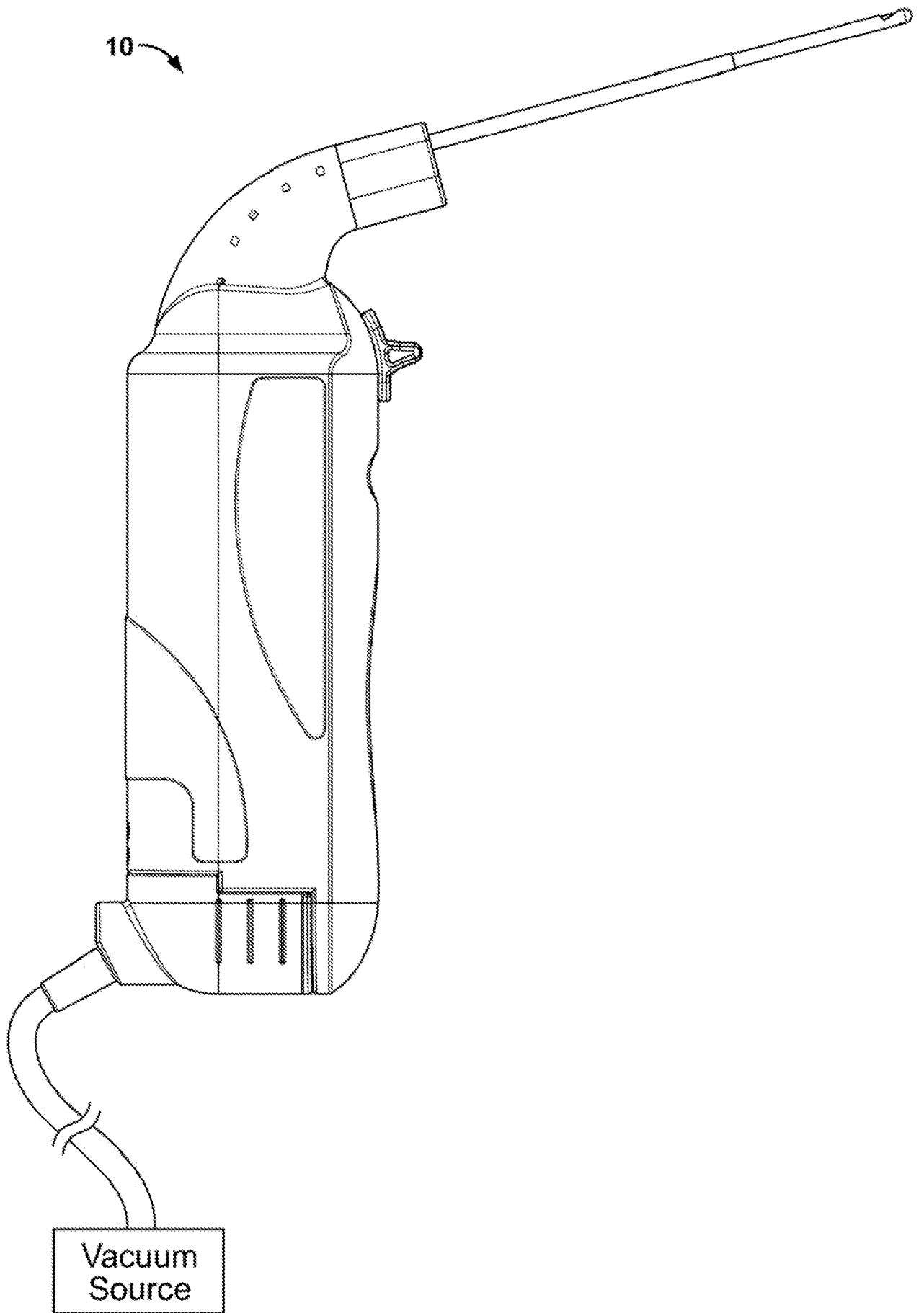

FIG. 1H

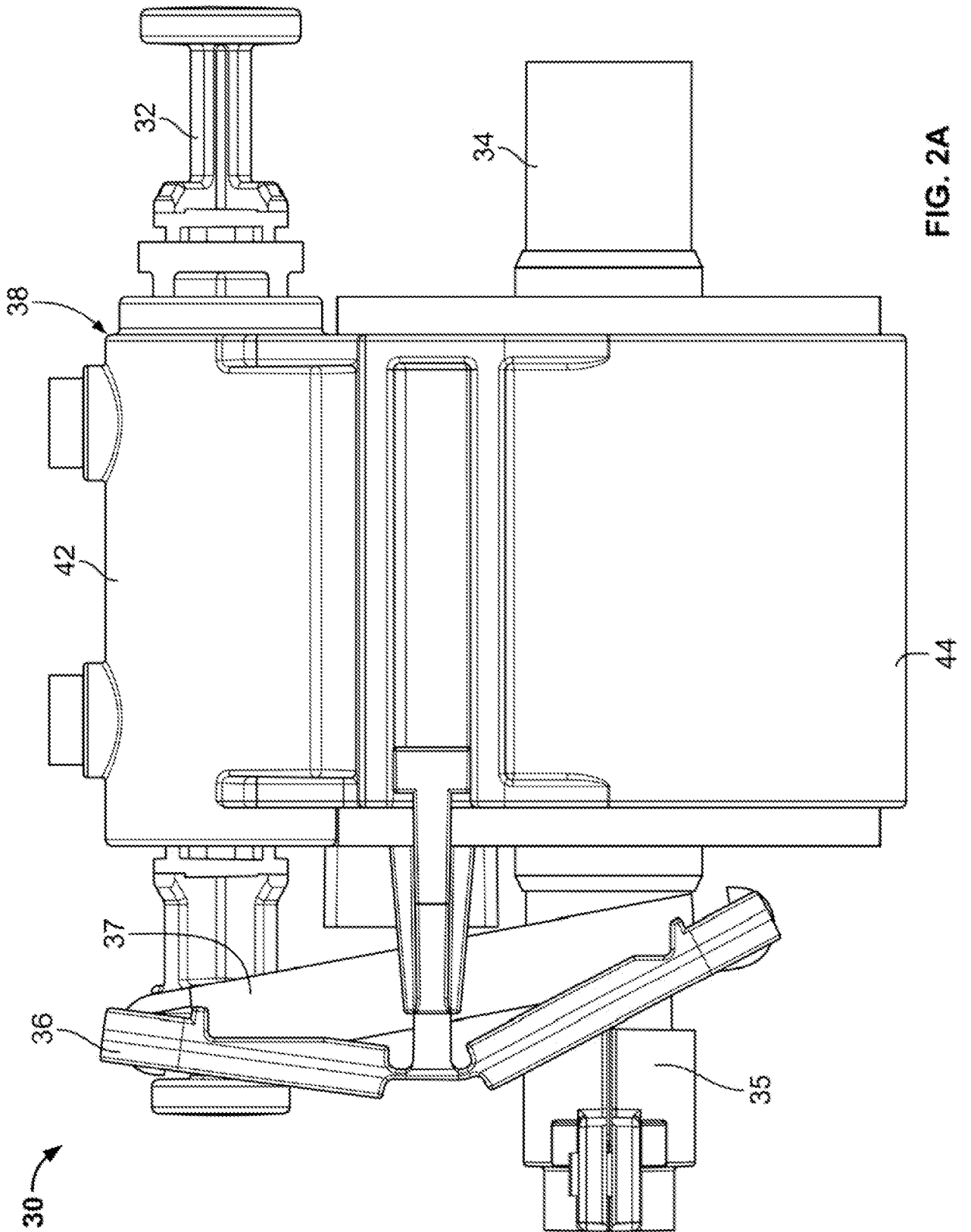

FIG. 2A

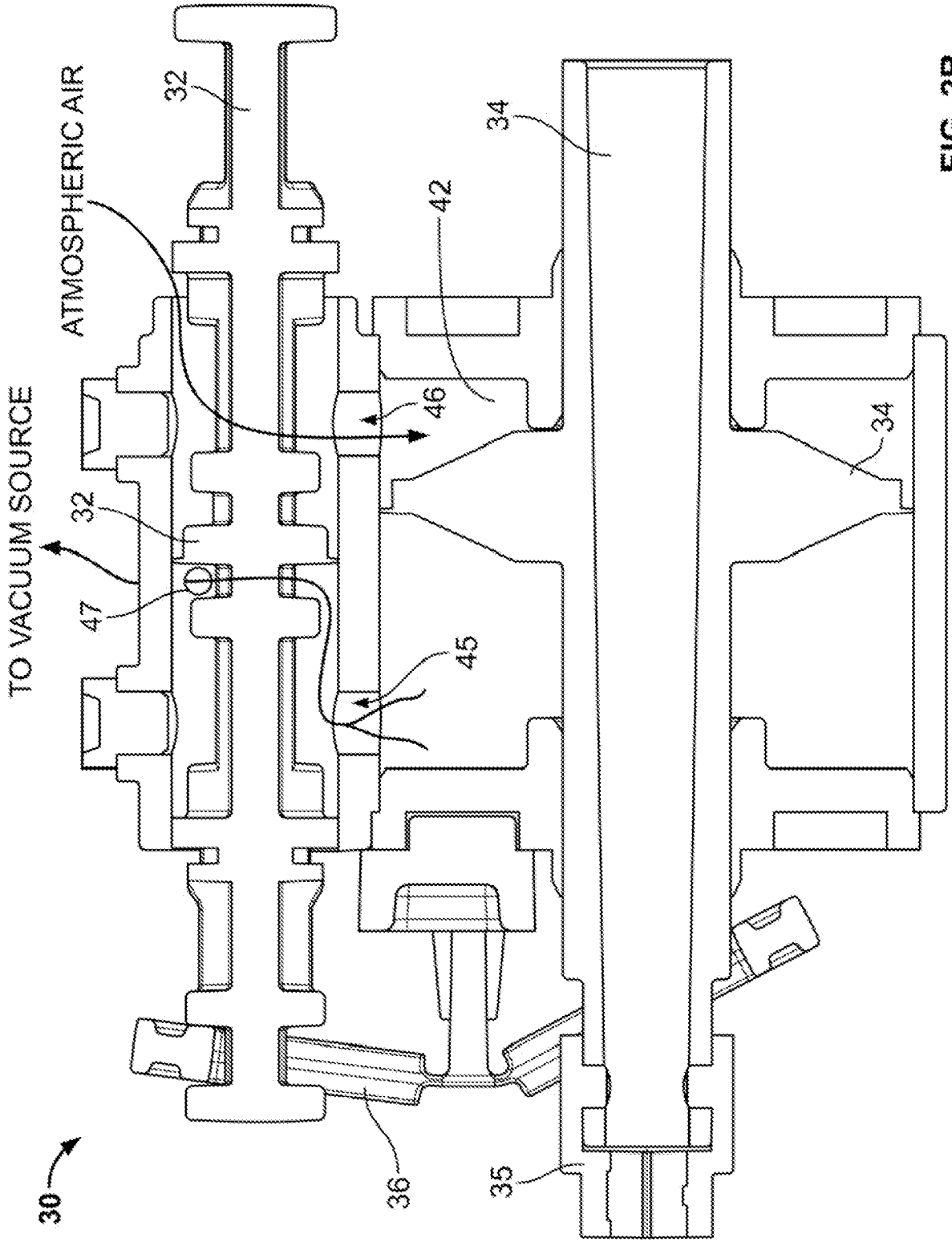
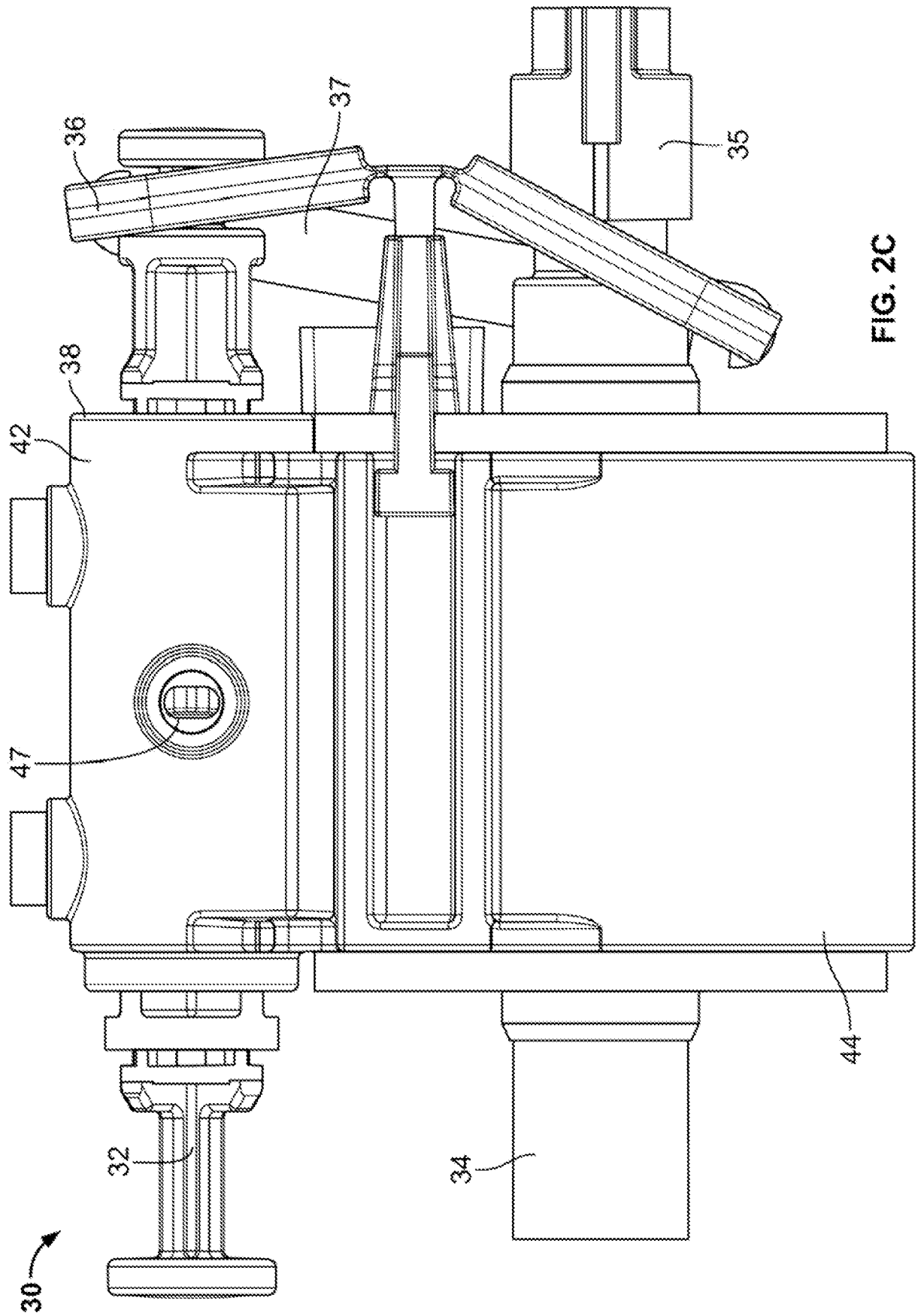

FIG. 2B





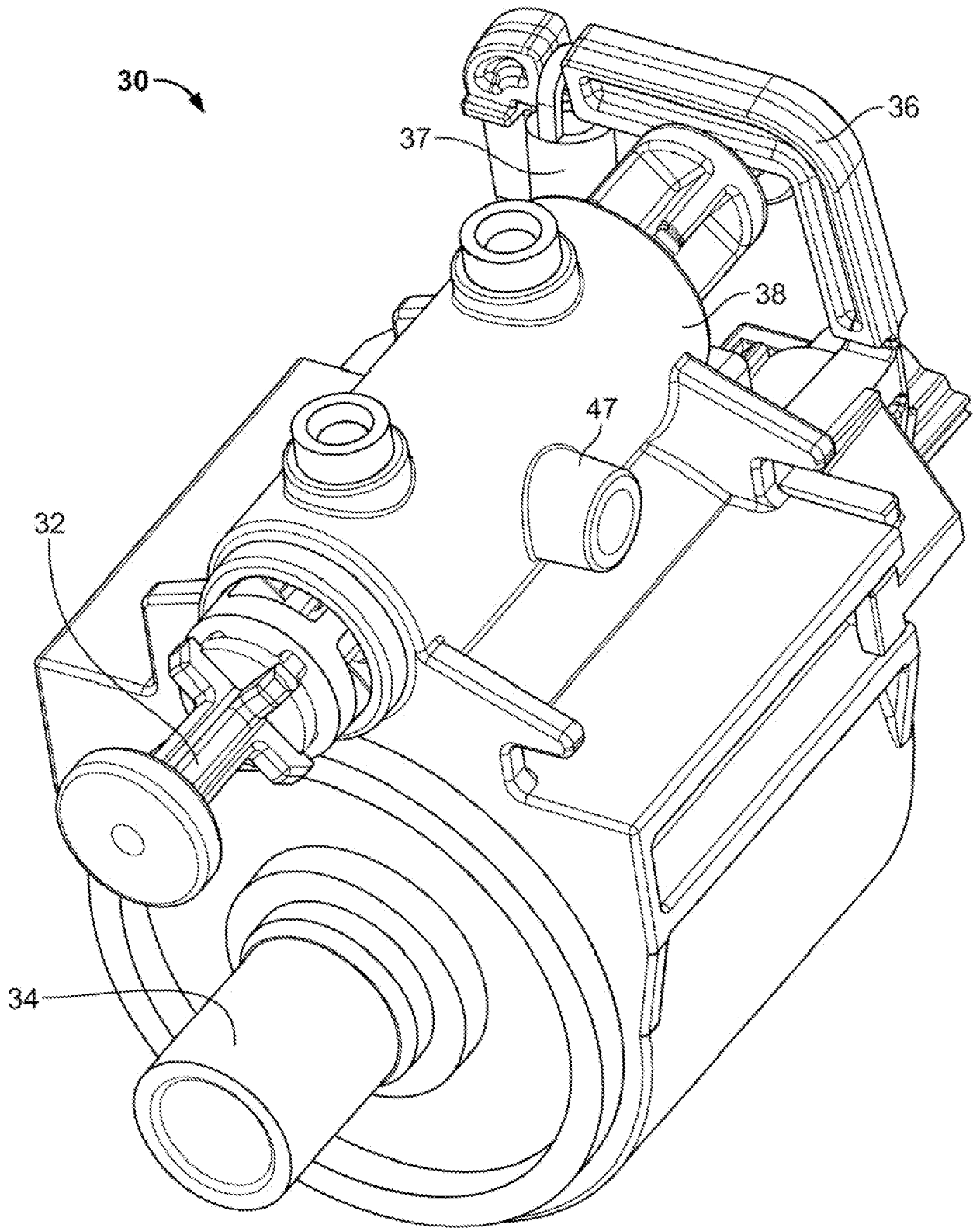

FIG. 2D

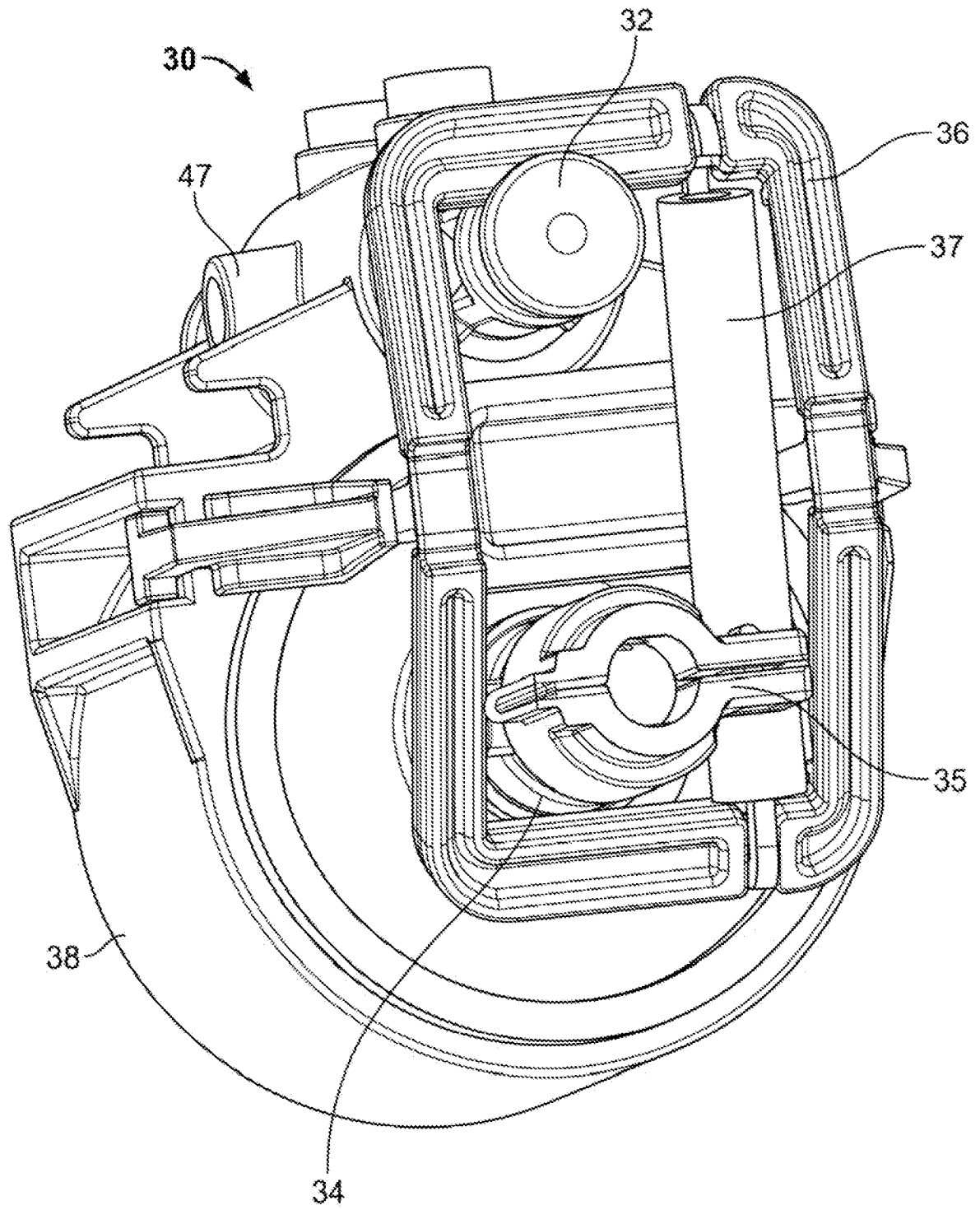
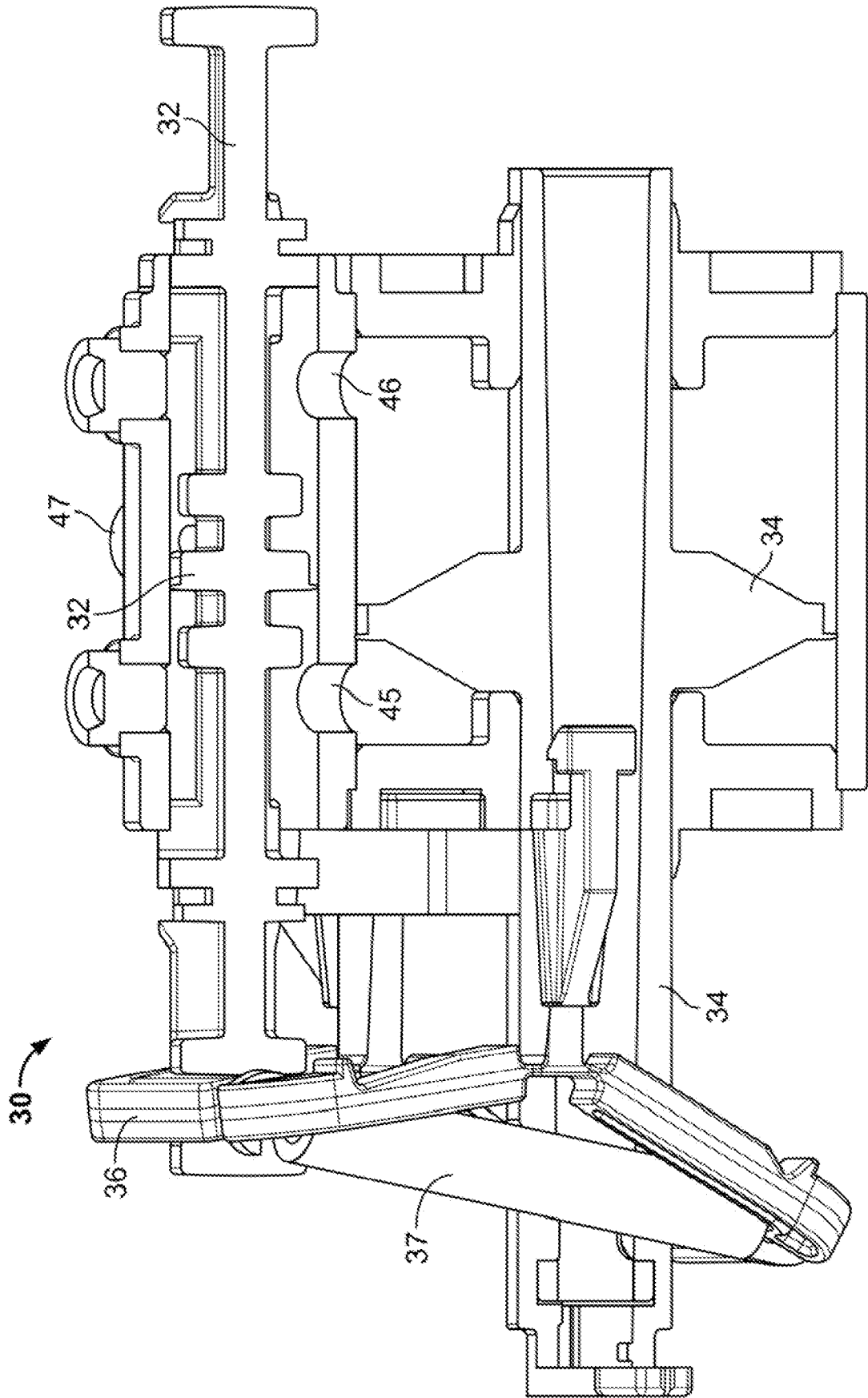

FIG. 2E



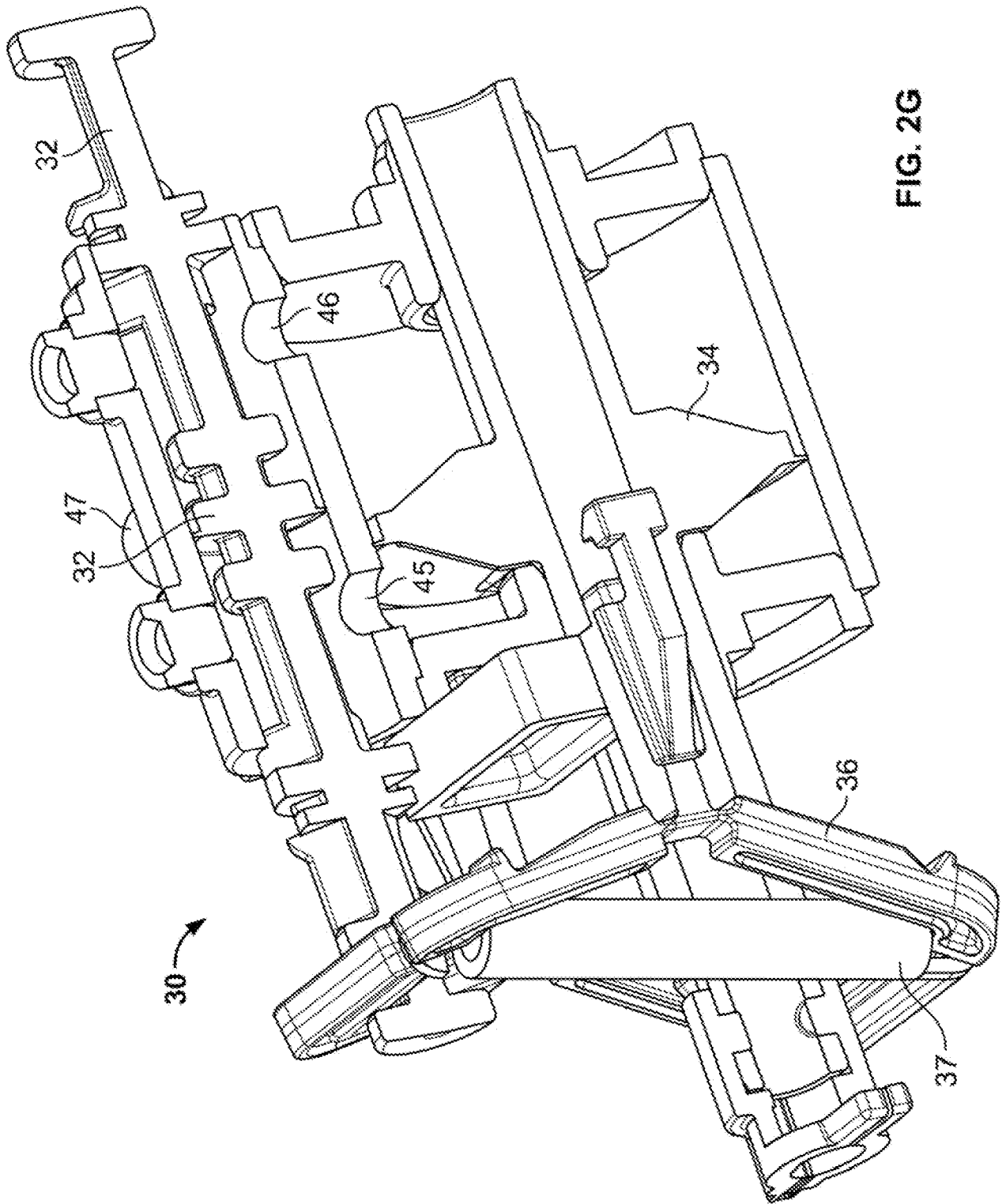

FIG. 2G

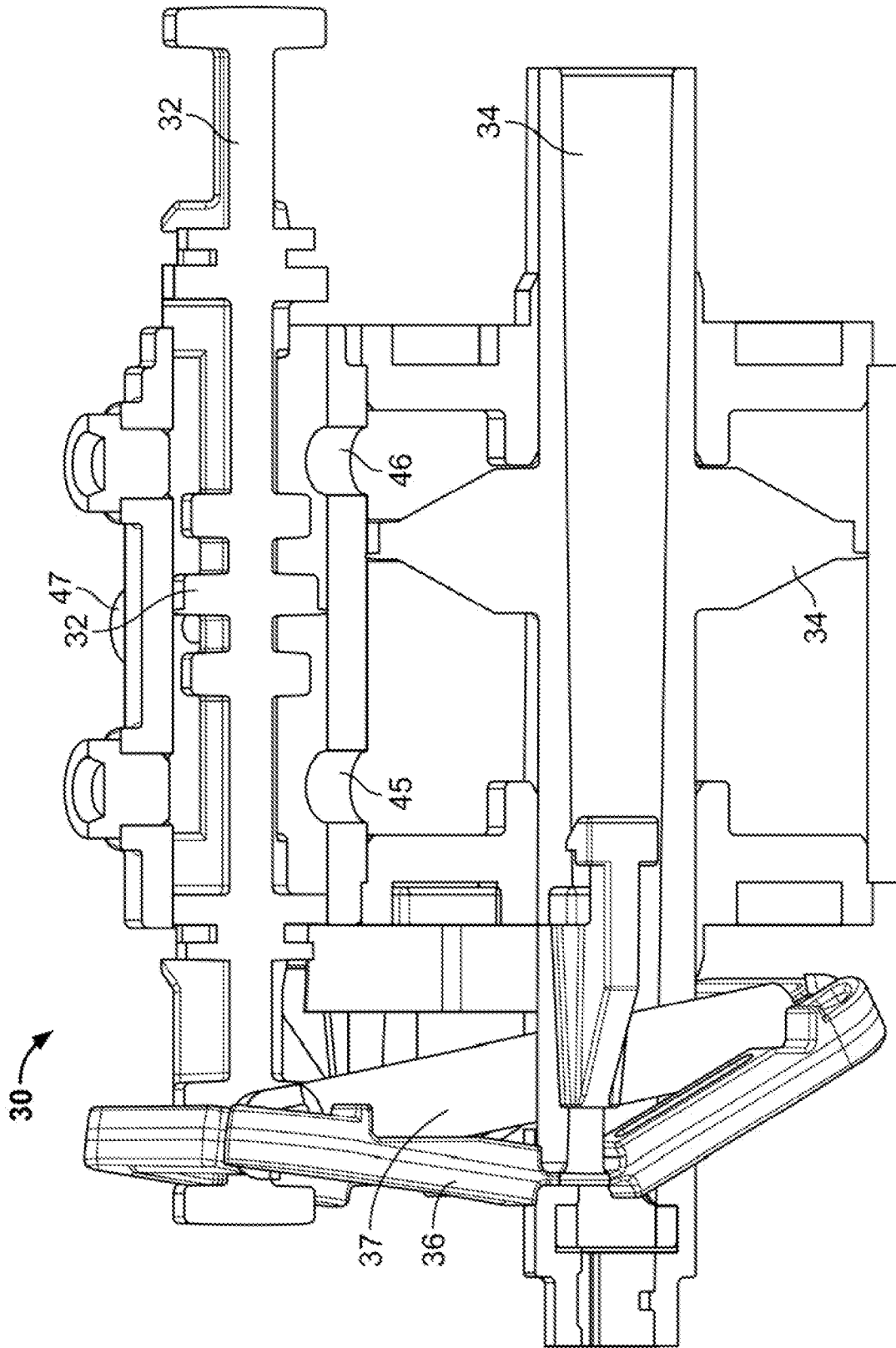

FIG. 2H

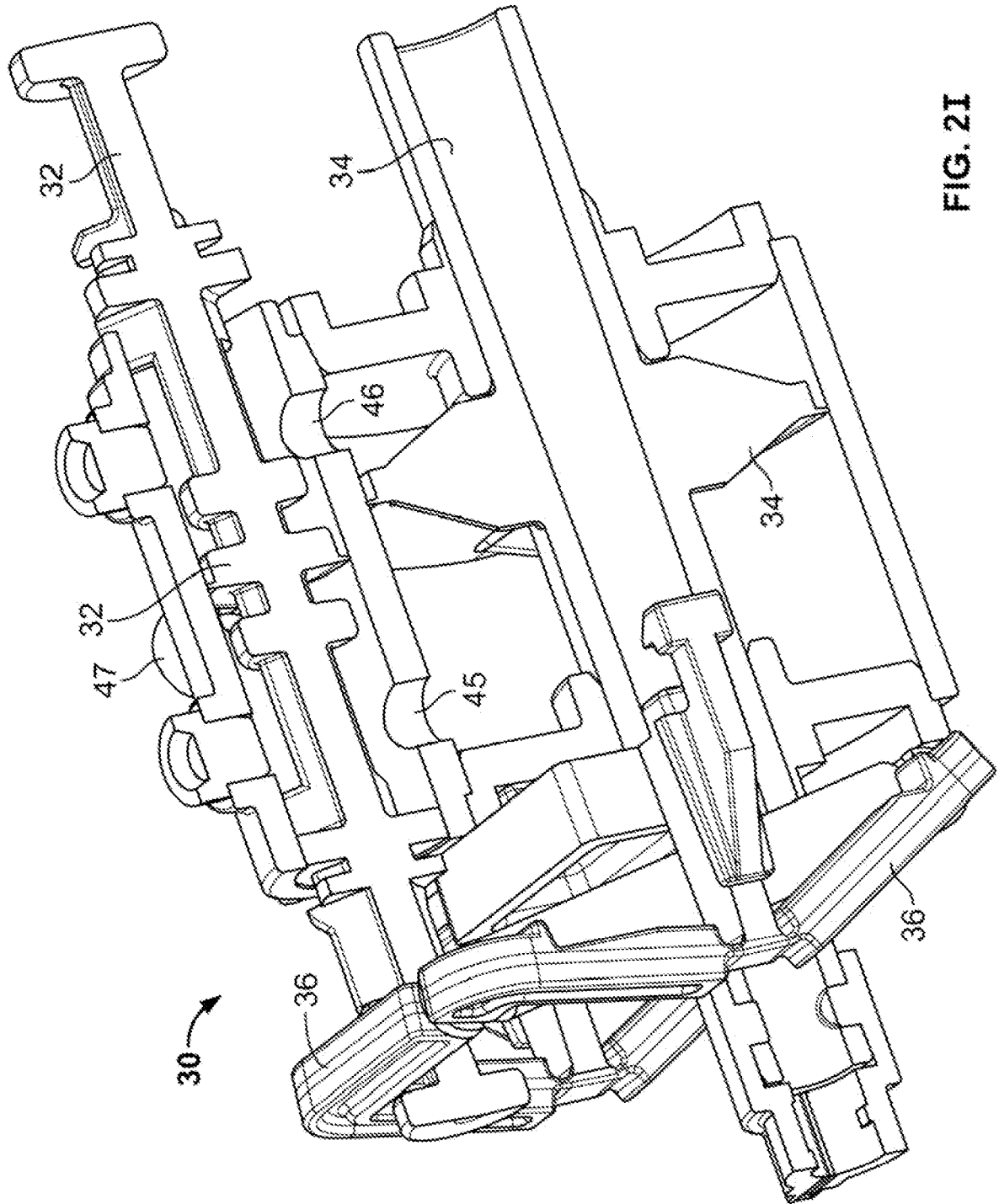

FIG. 21





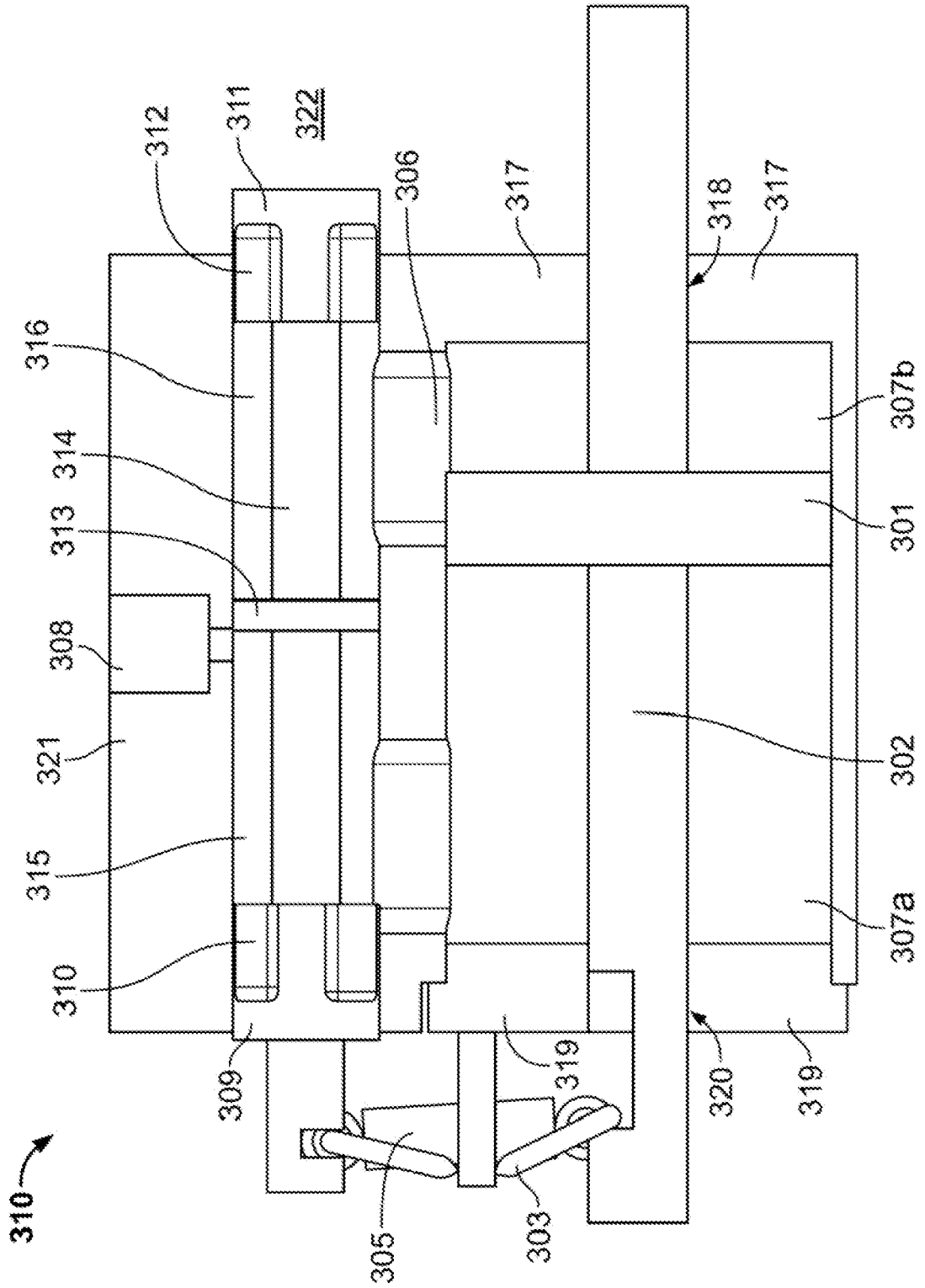
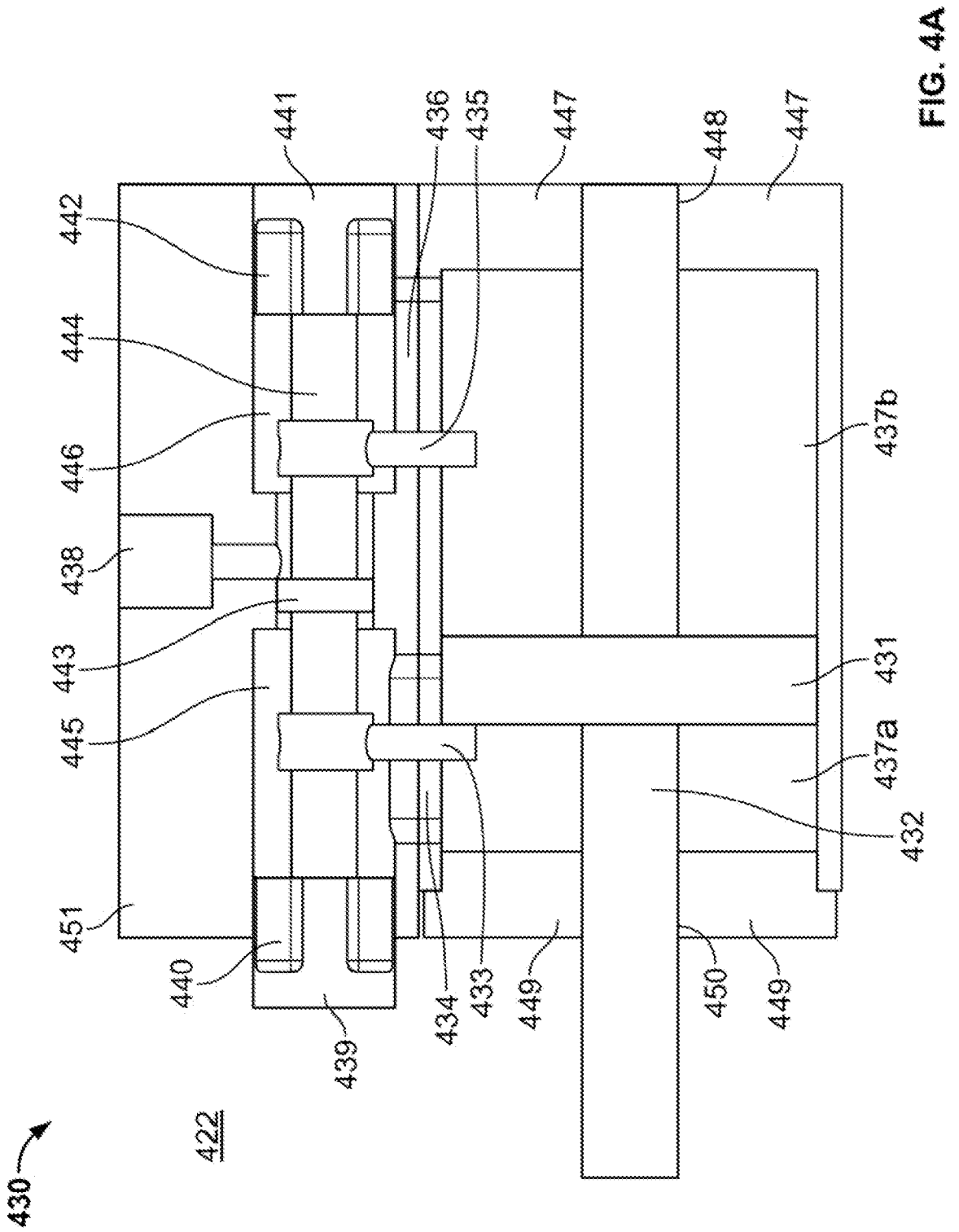

FIG. 3B



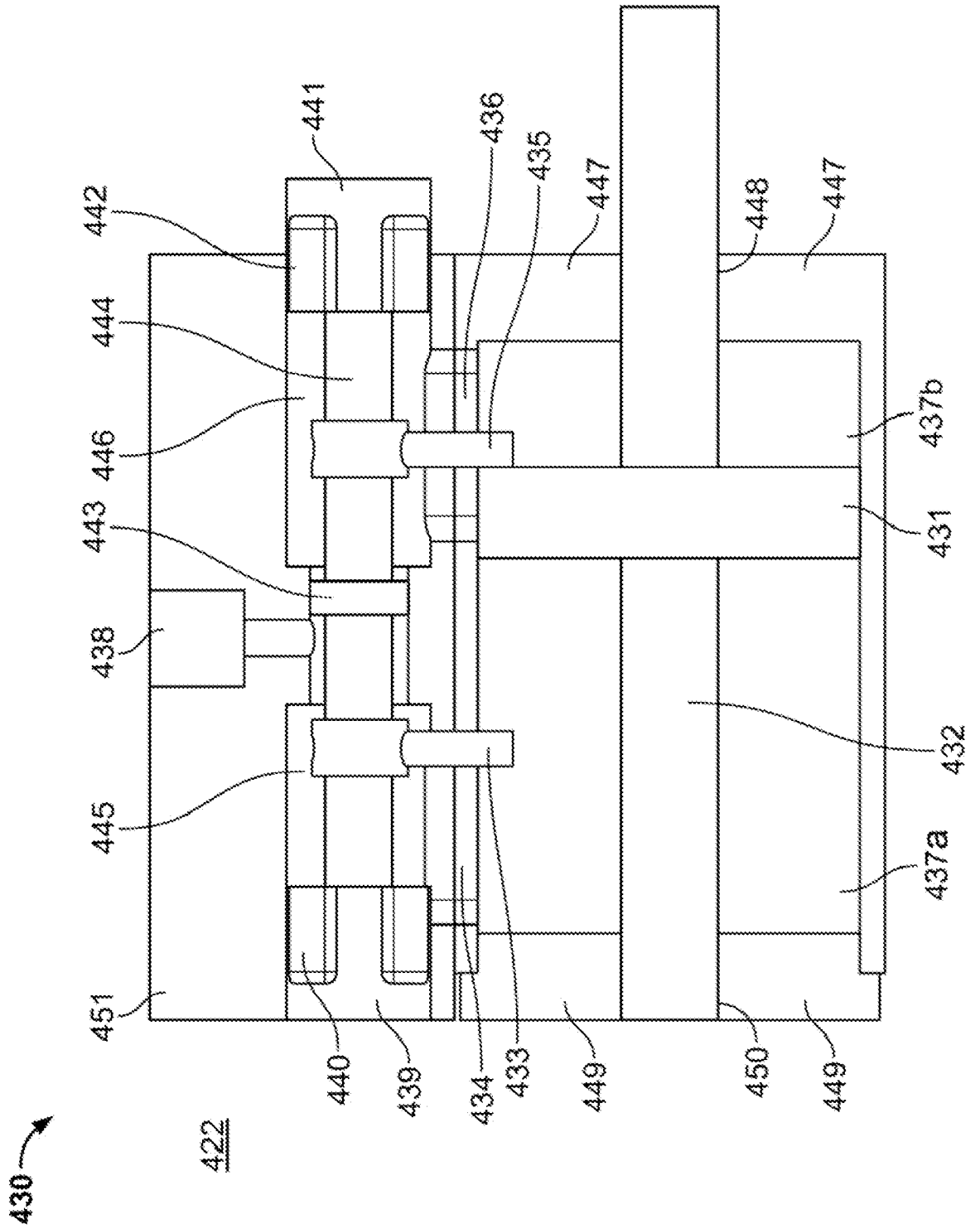

FIG. 4B

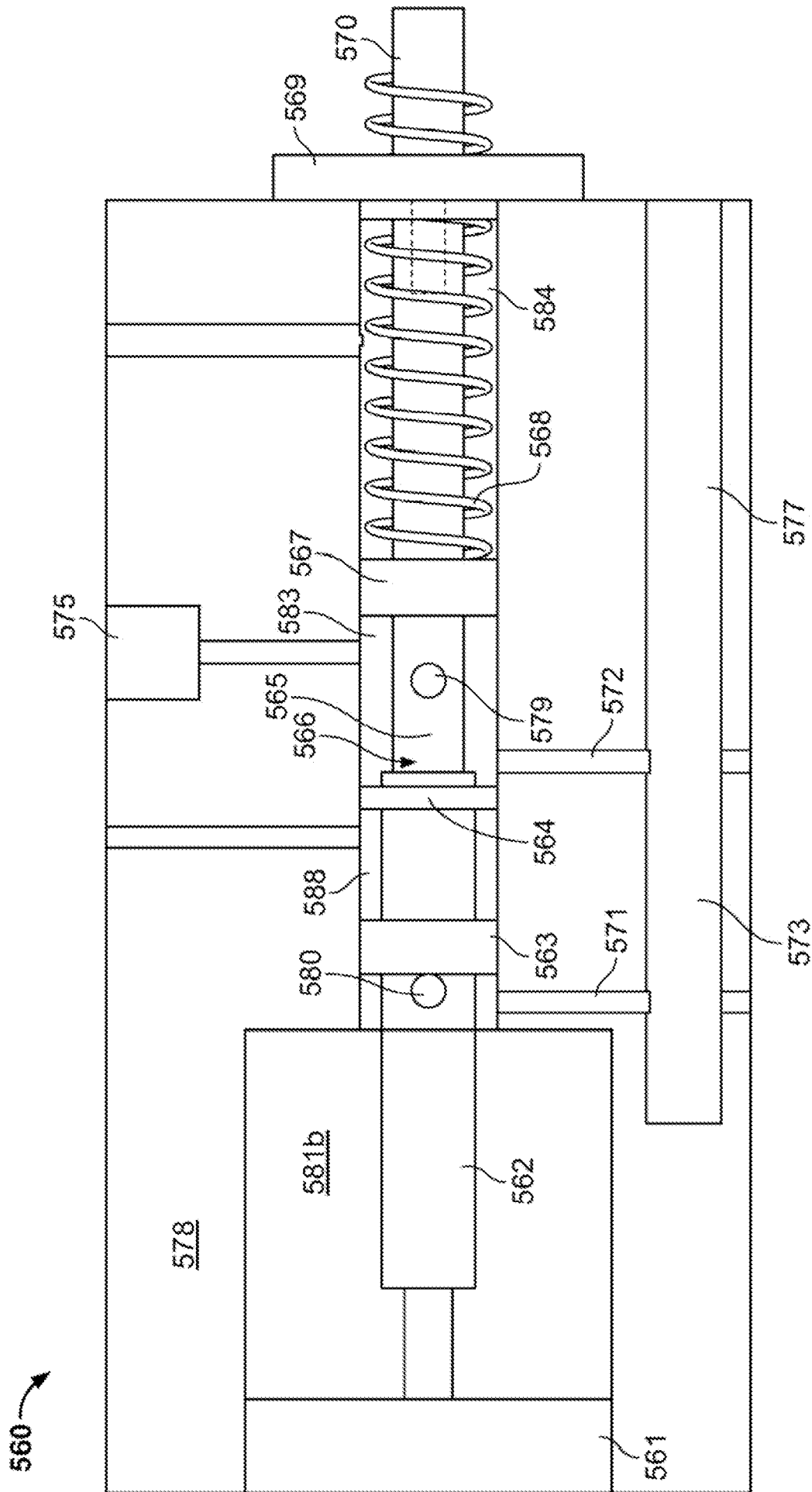

FIG. 5A

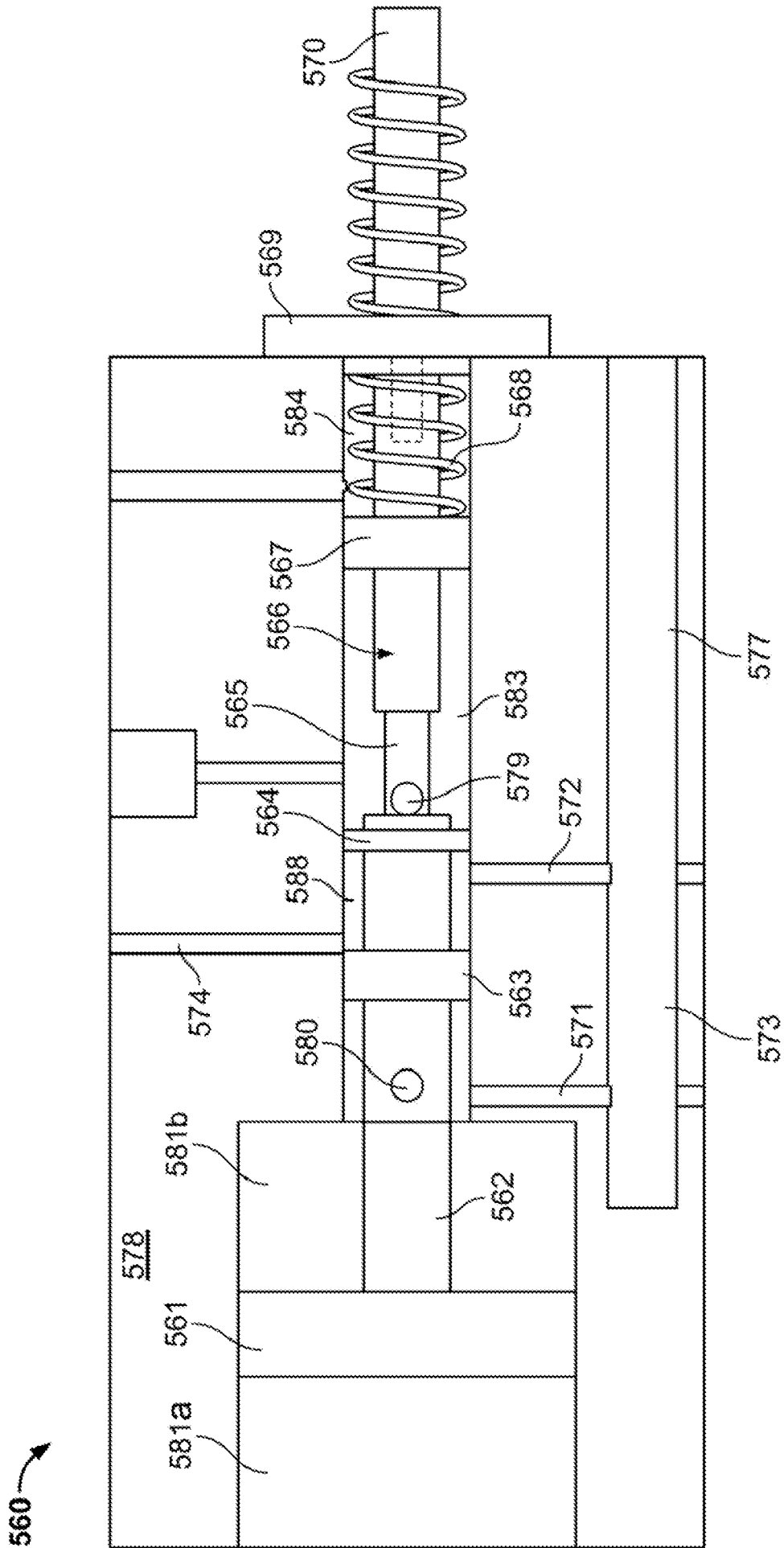

FIG. 5B

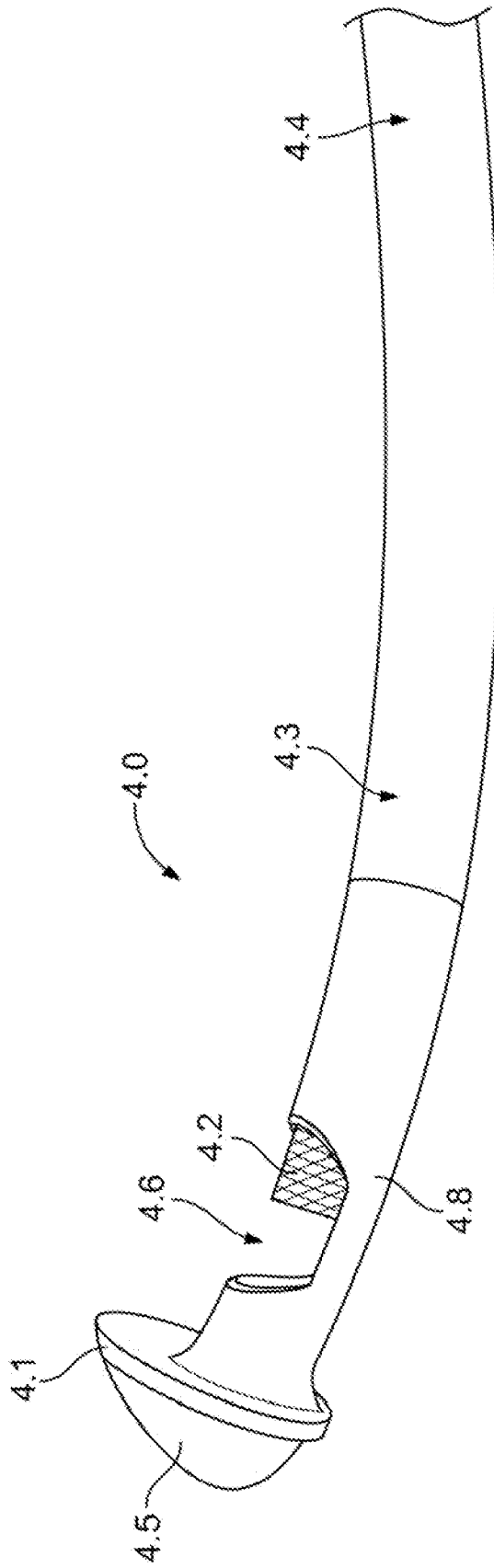

FIG. 6

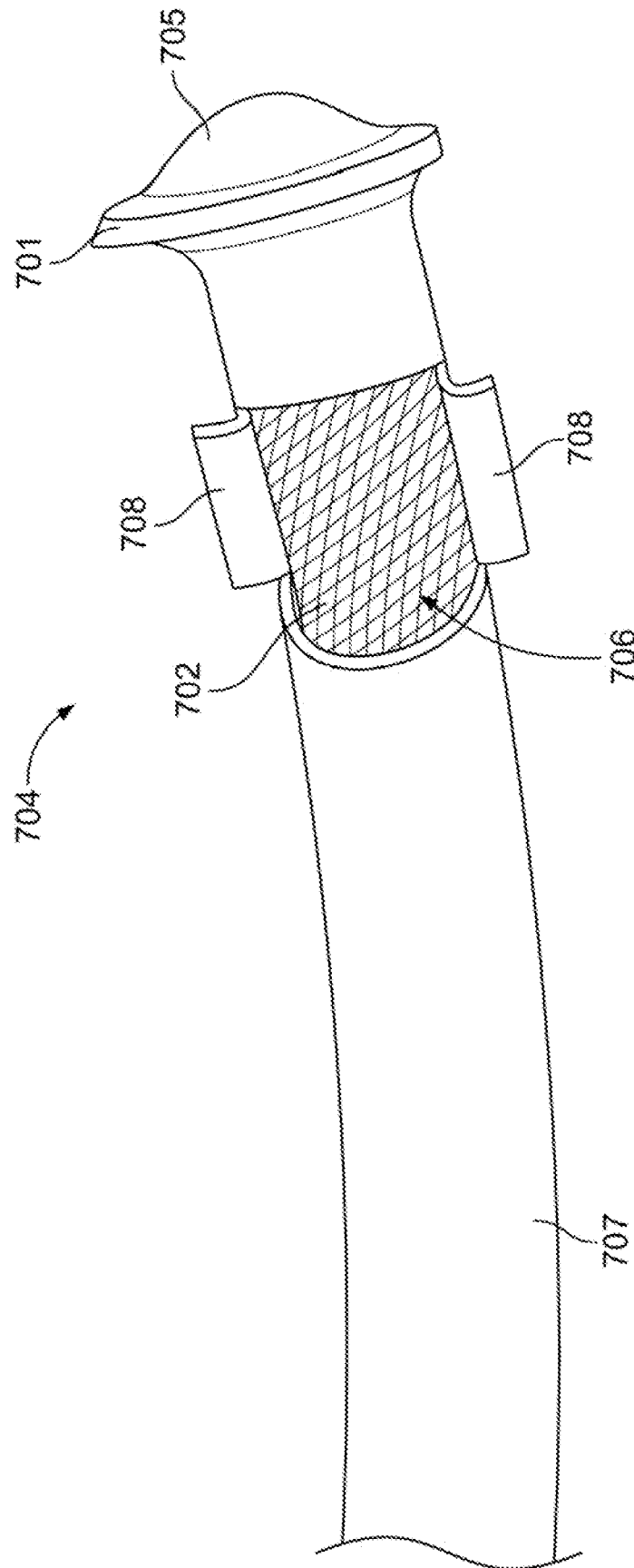

FIG. 7

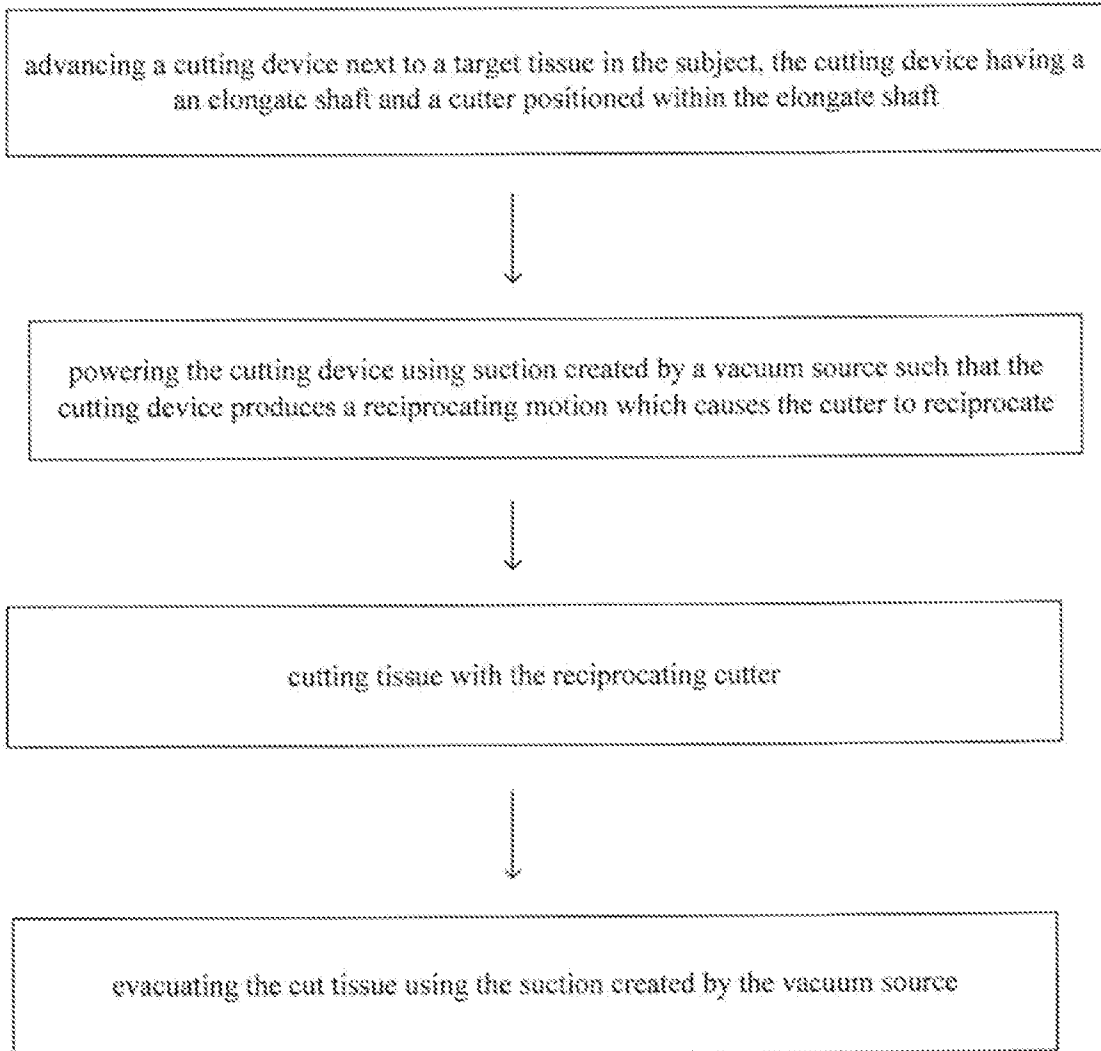

Fig. 8



27/41

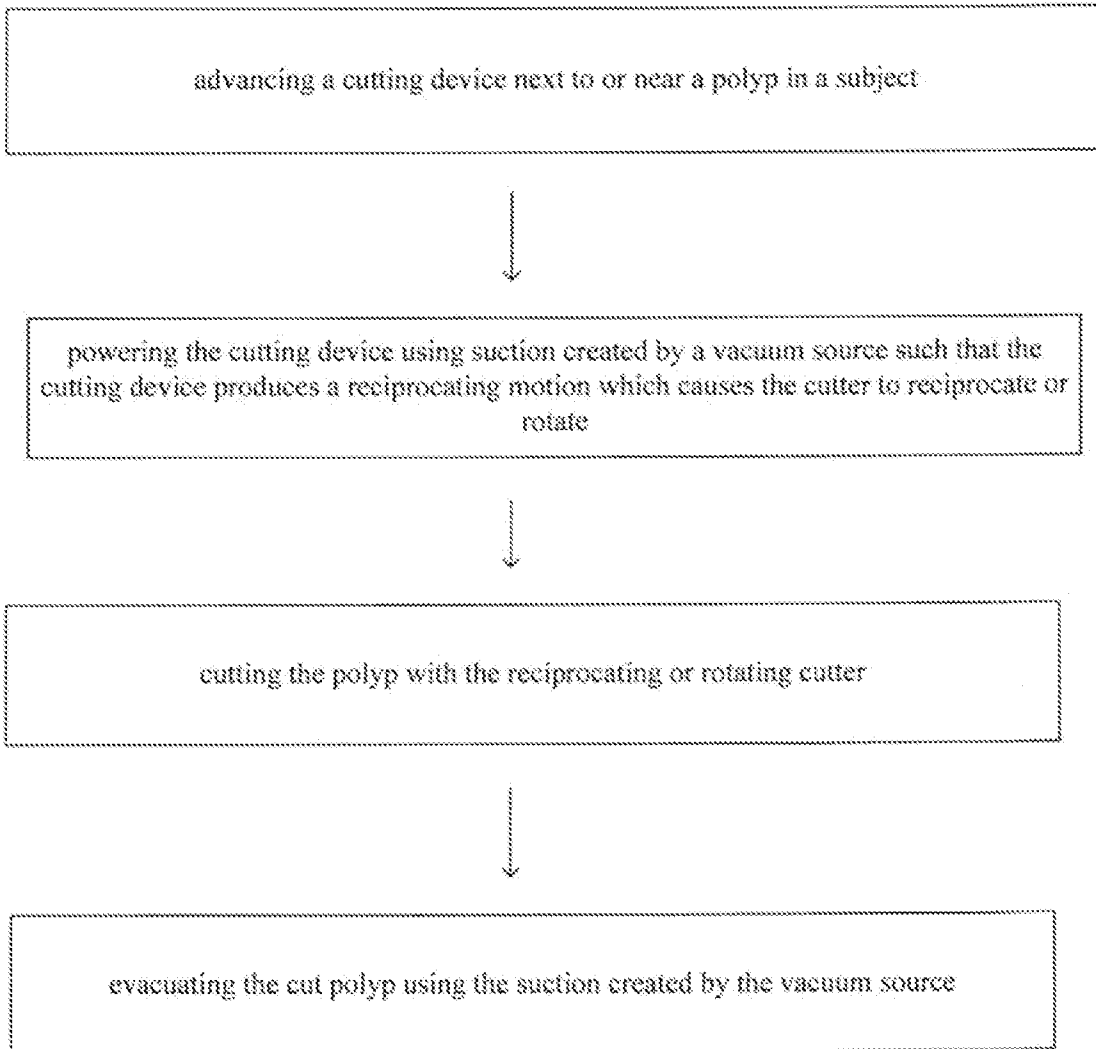

Fig. 9

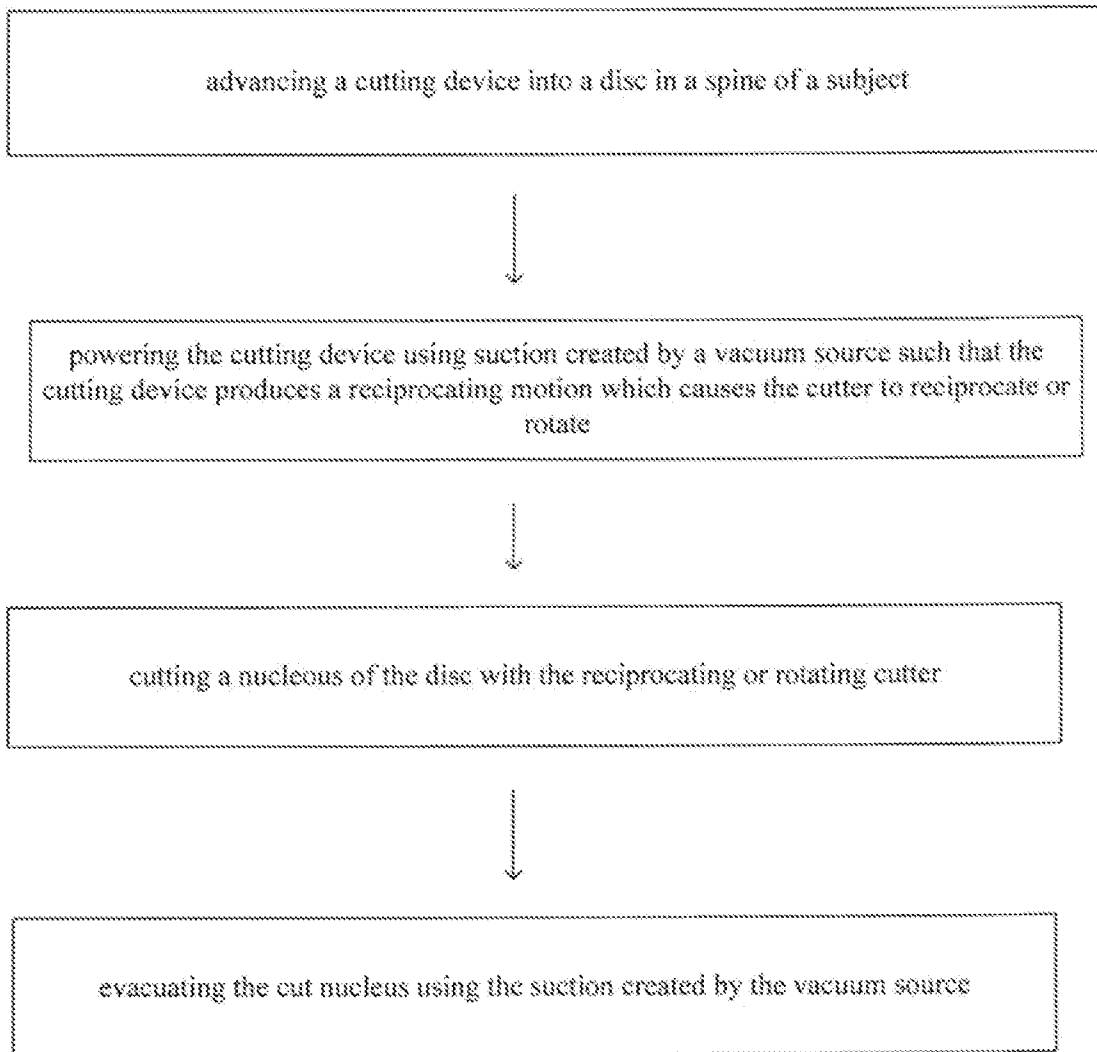
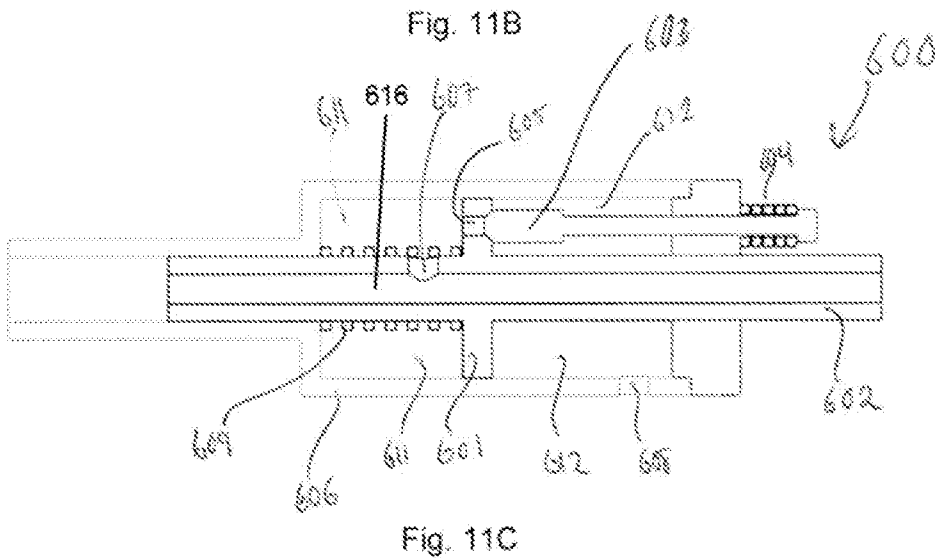
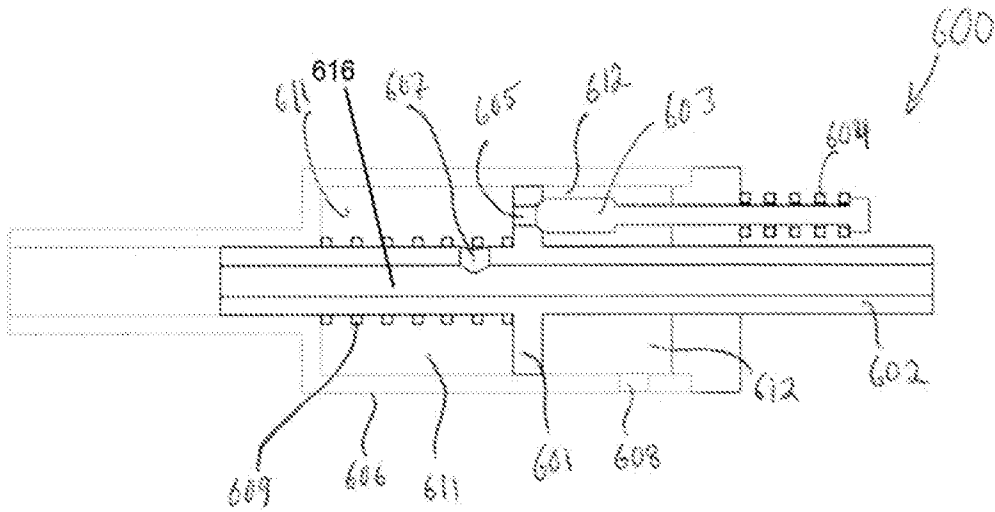
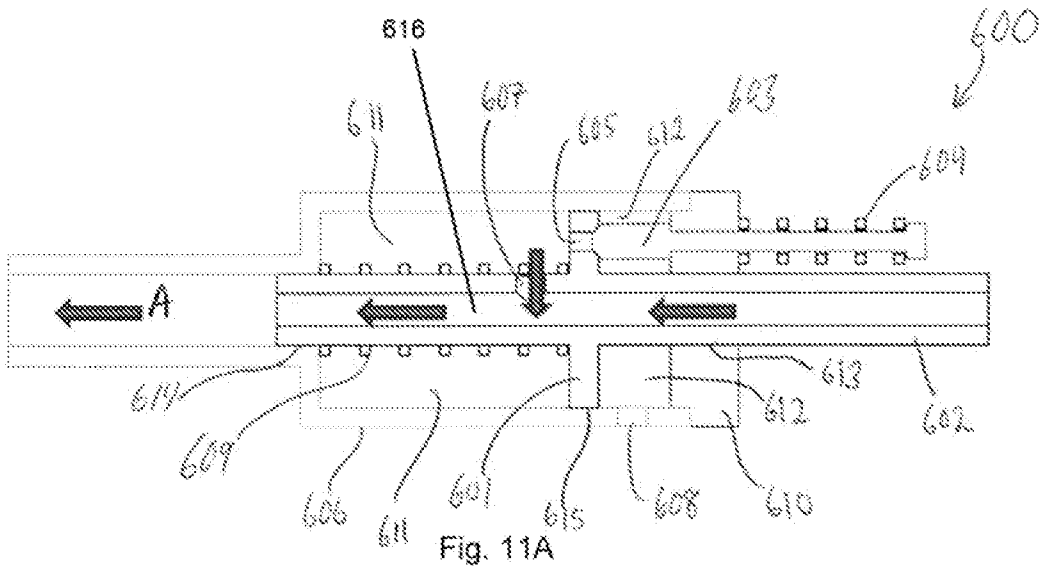

Fig. 10



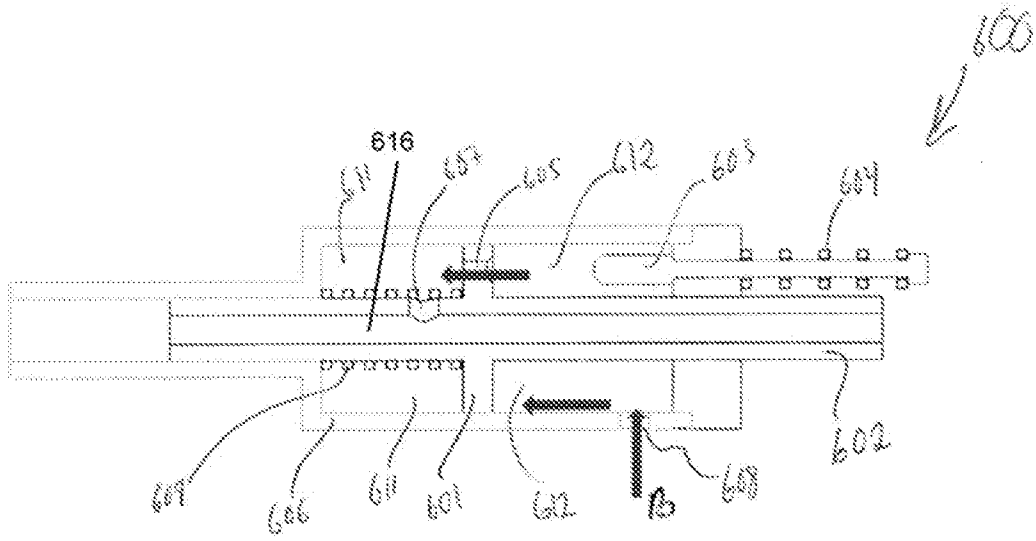

Fig. 11D

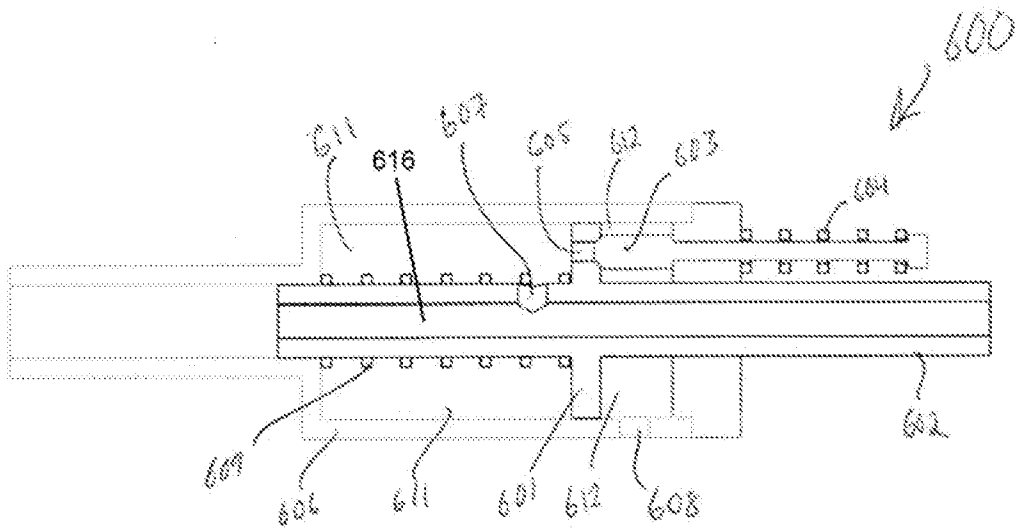

Fig. 11E

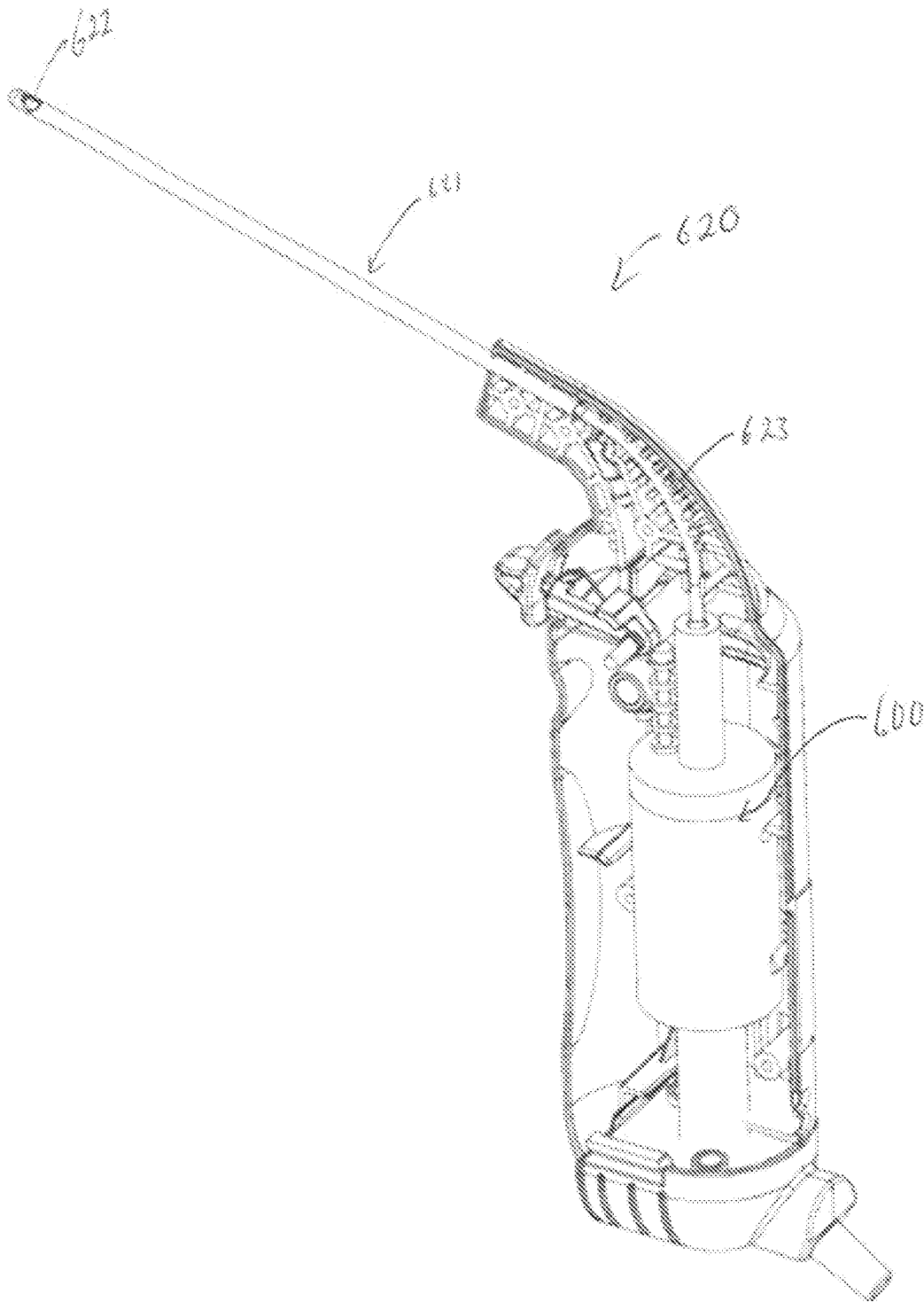

Fig. 12A

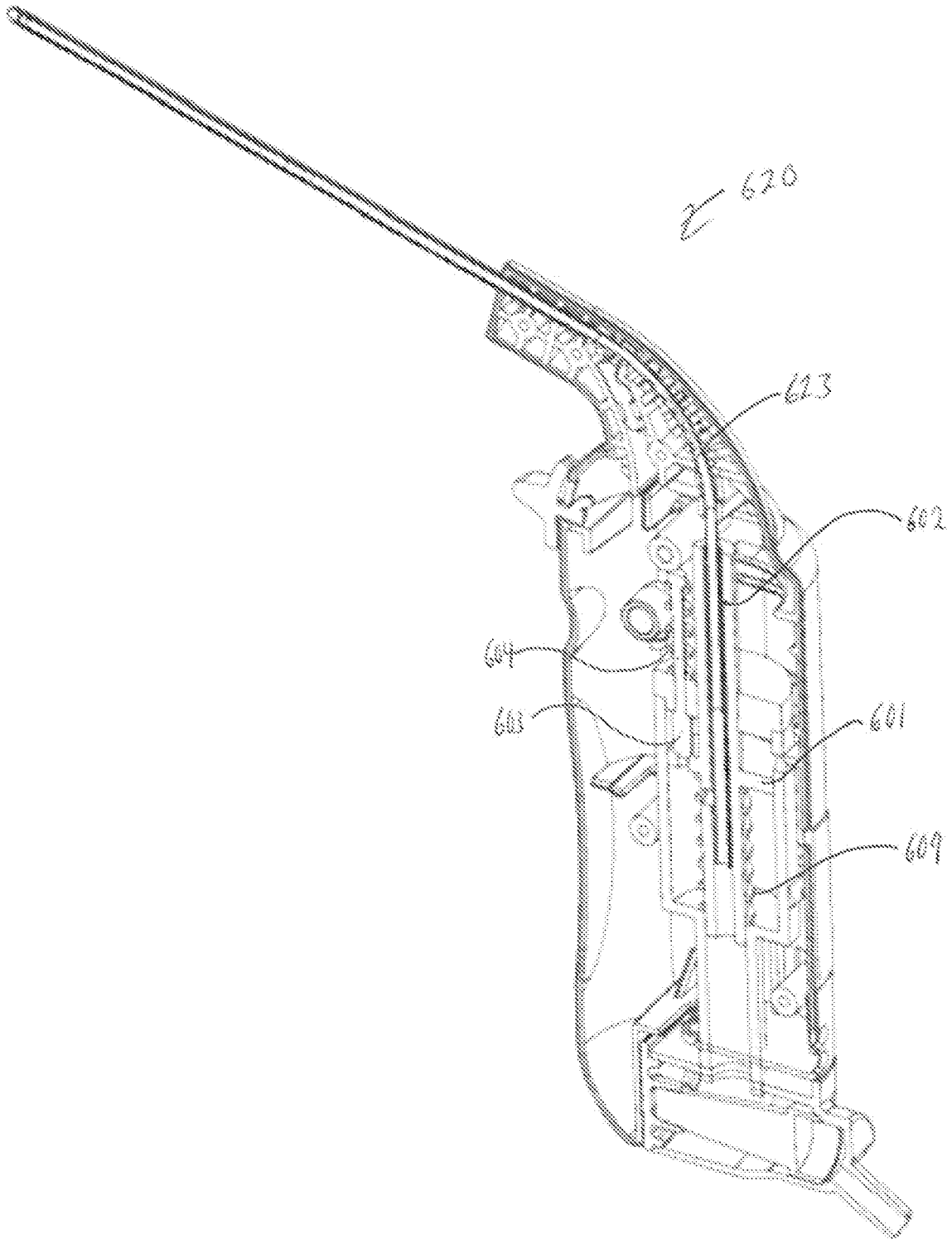

Fig. 12B

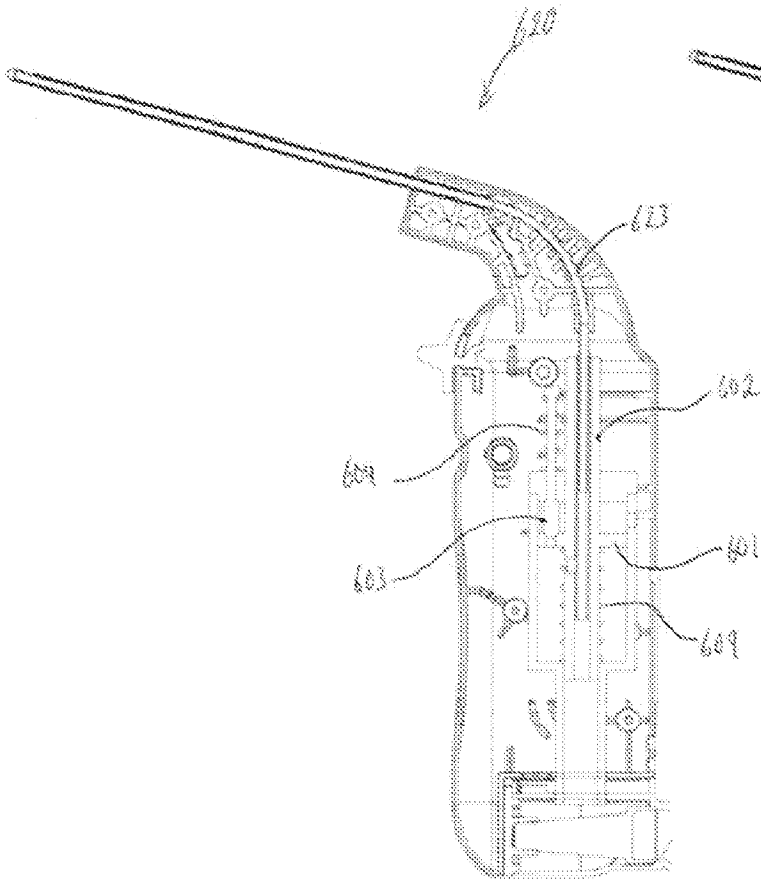

Fig. 12C

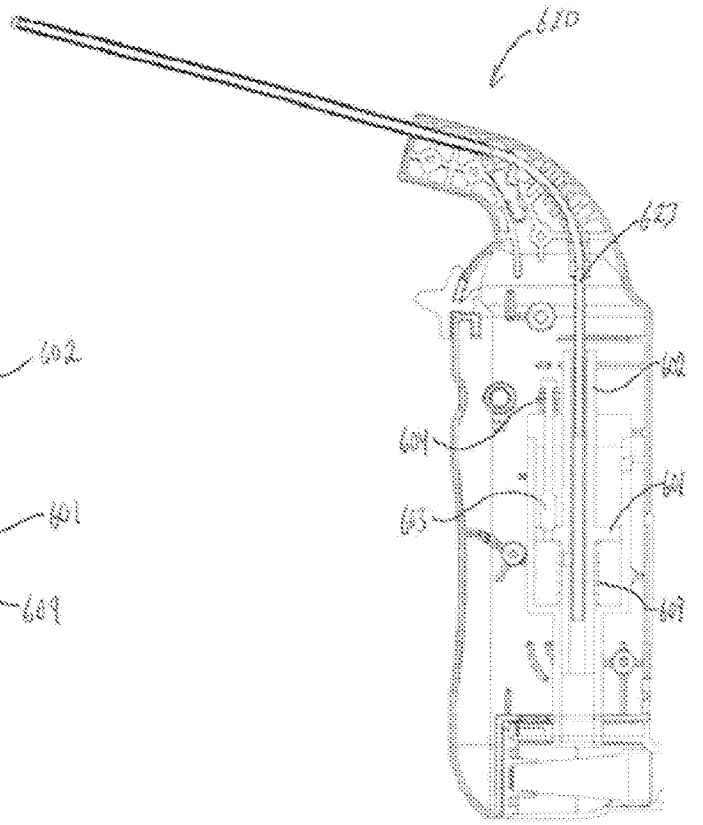

Fig. 2D

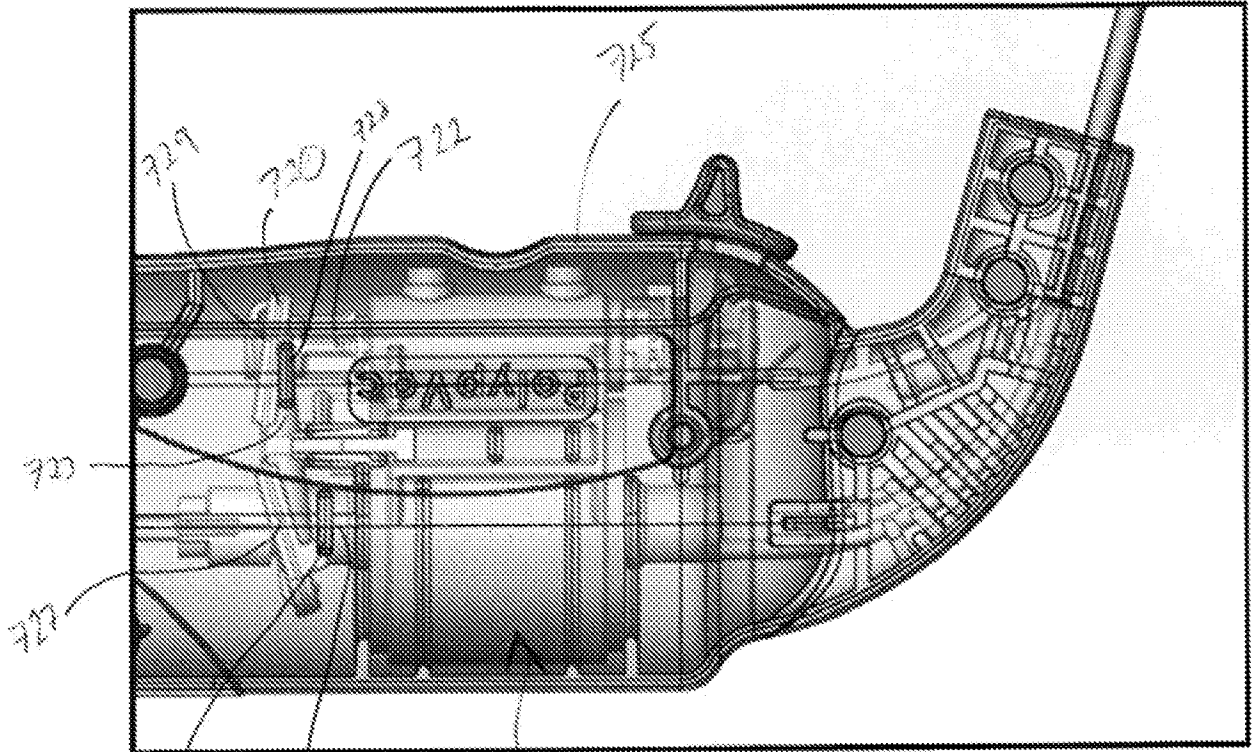

Fig. 13A

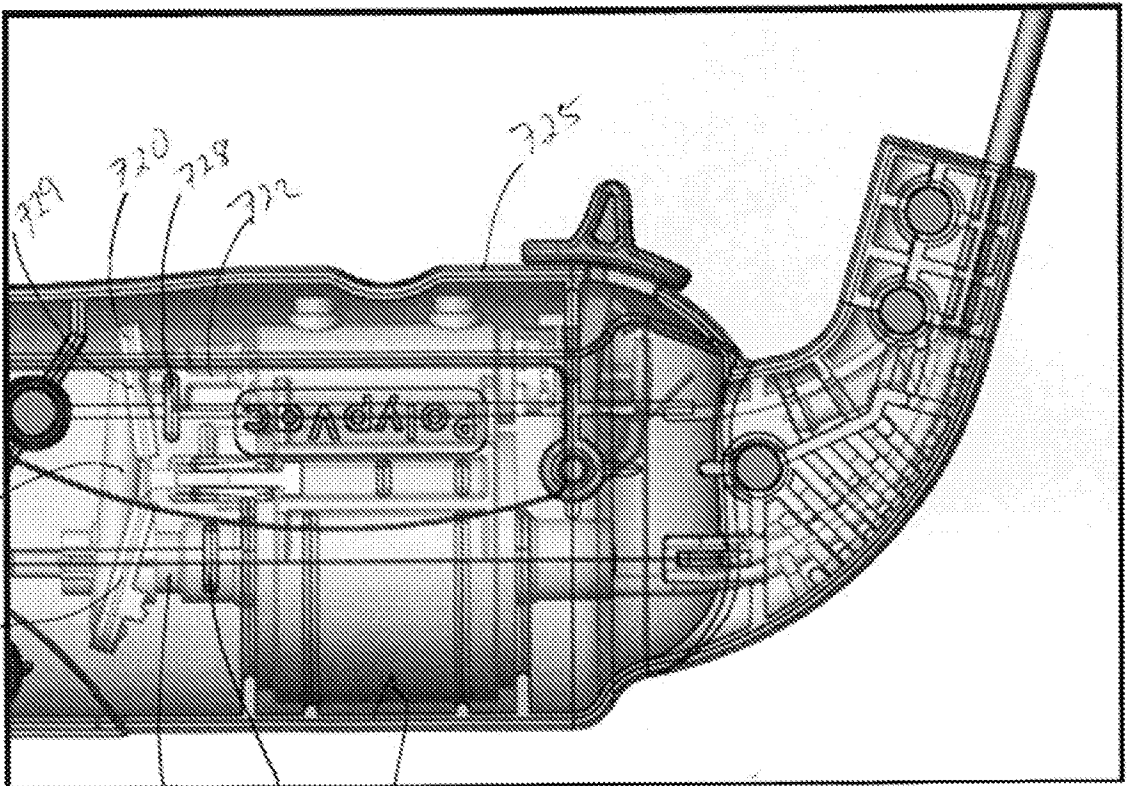

Fig. 13B



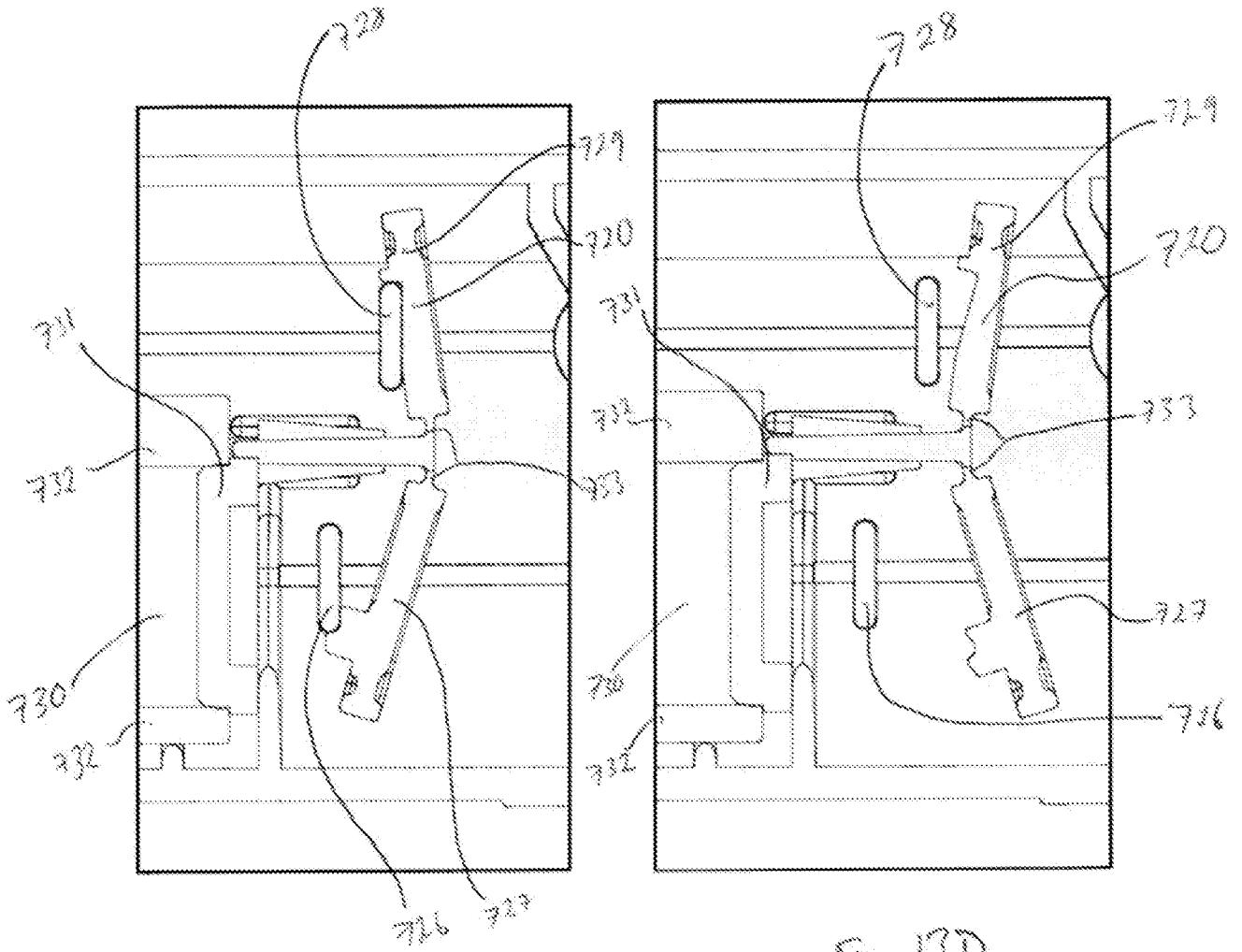

Fig 13C

Fig 13D

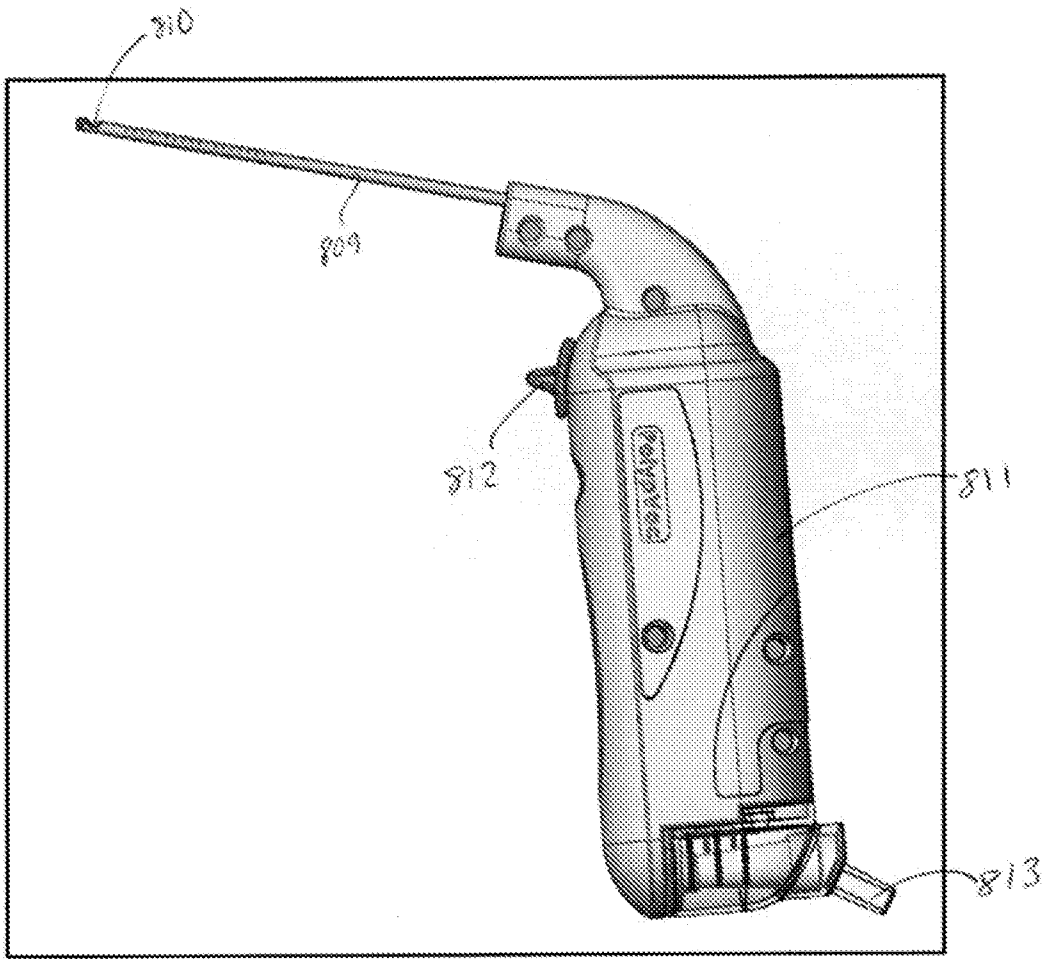
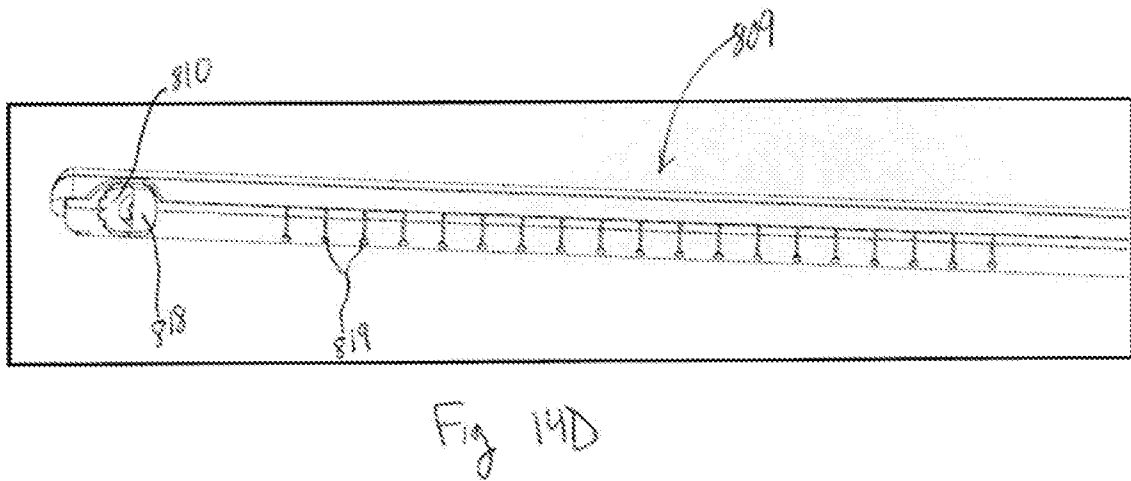
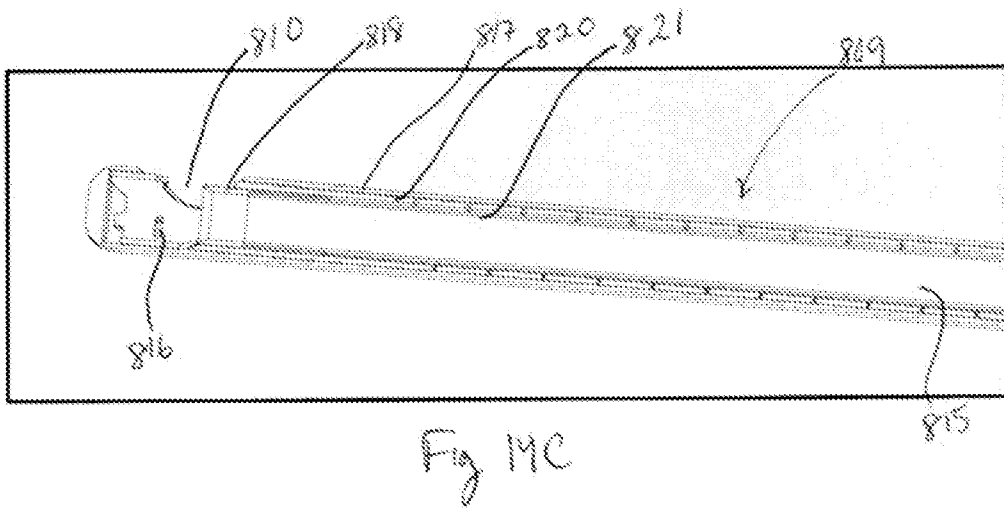
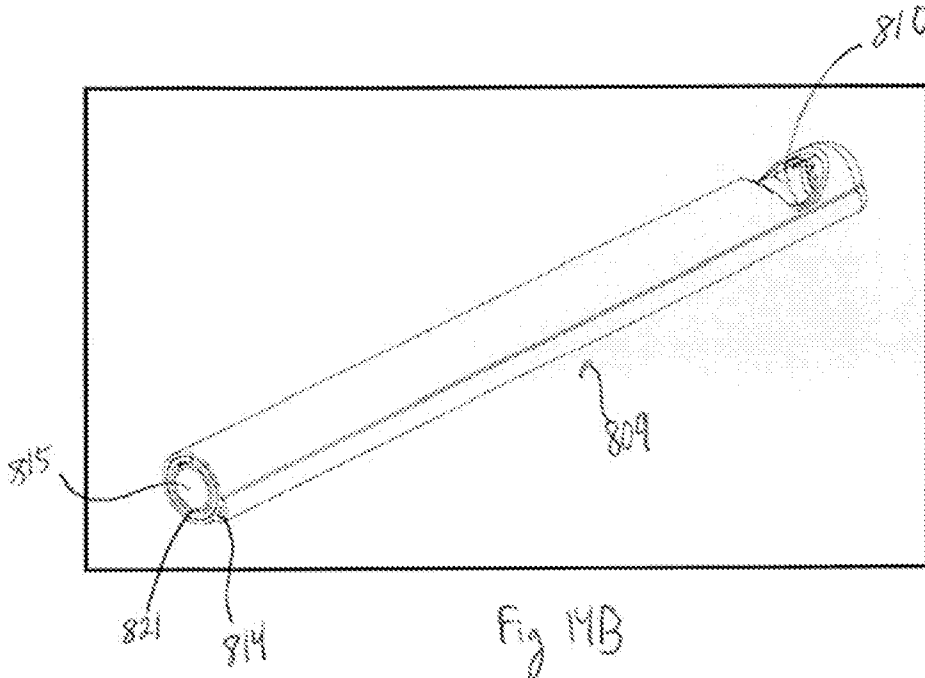

Fig 14A

37/41



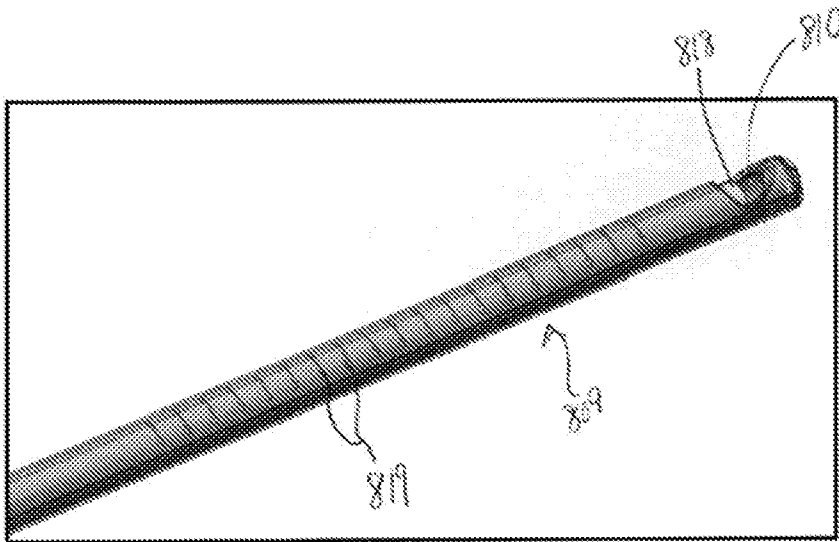

Fig. 14E

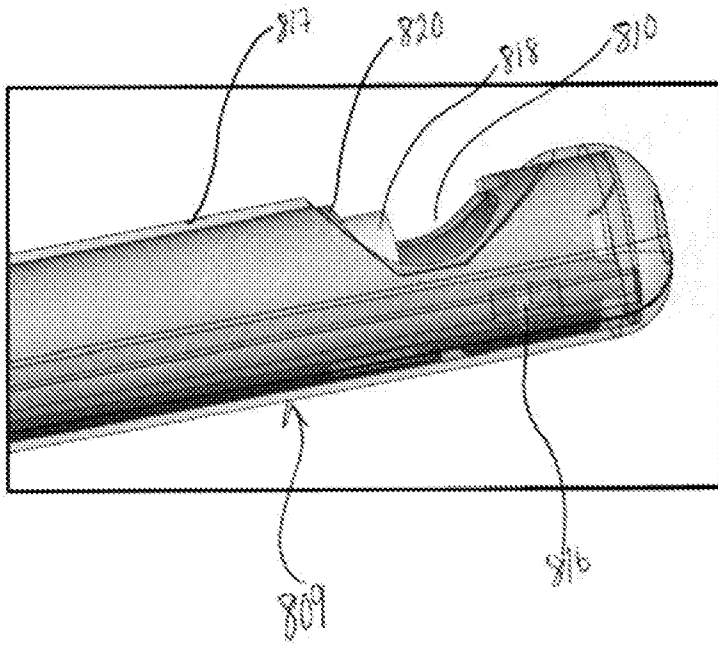

Fig. 14F

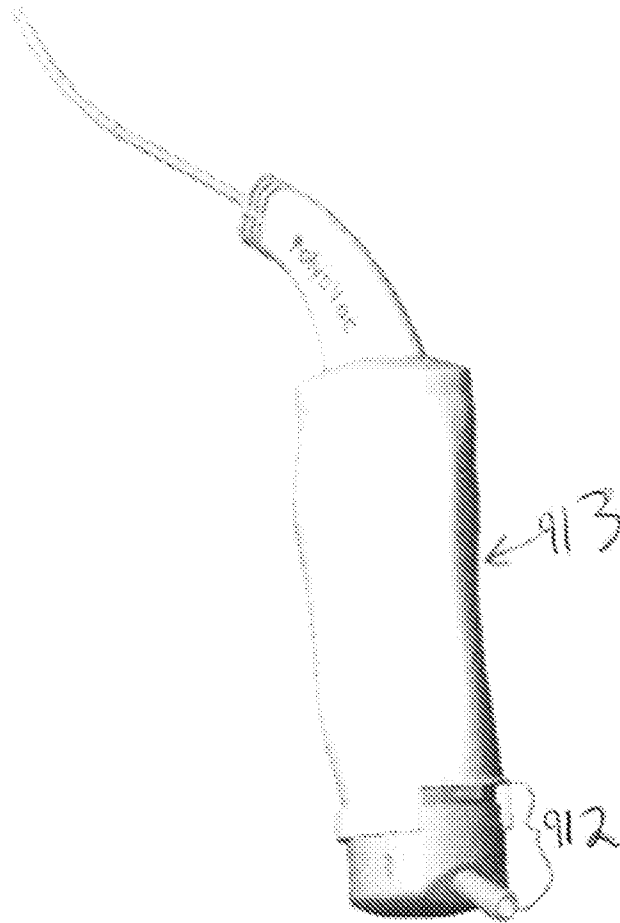

Fig. 15A

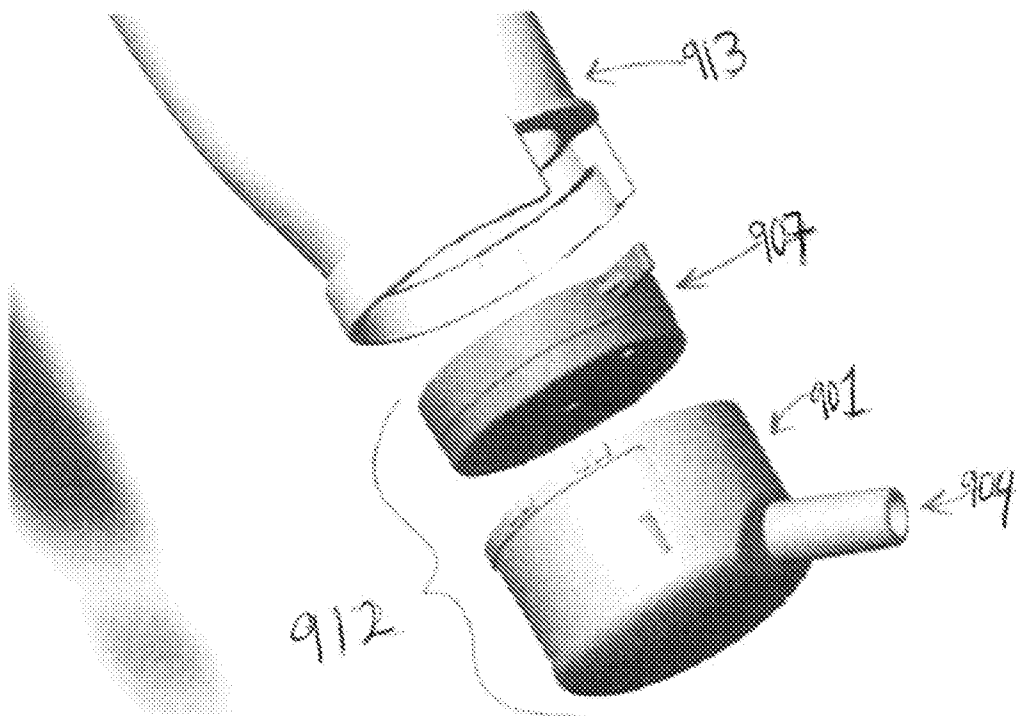

Fig. 15B

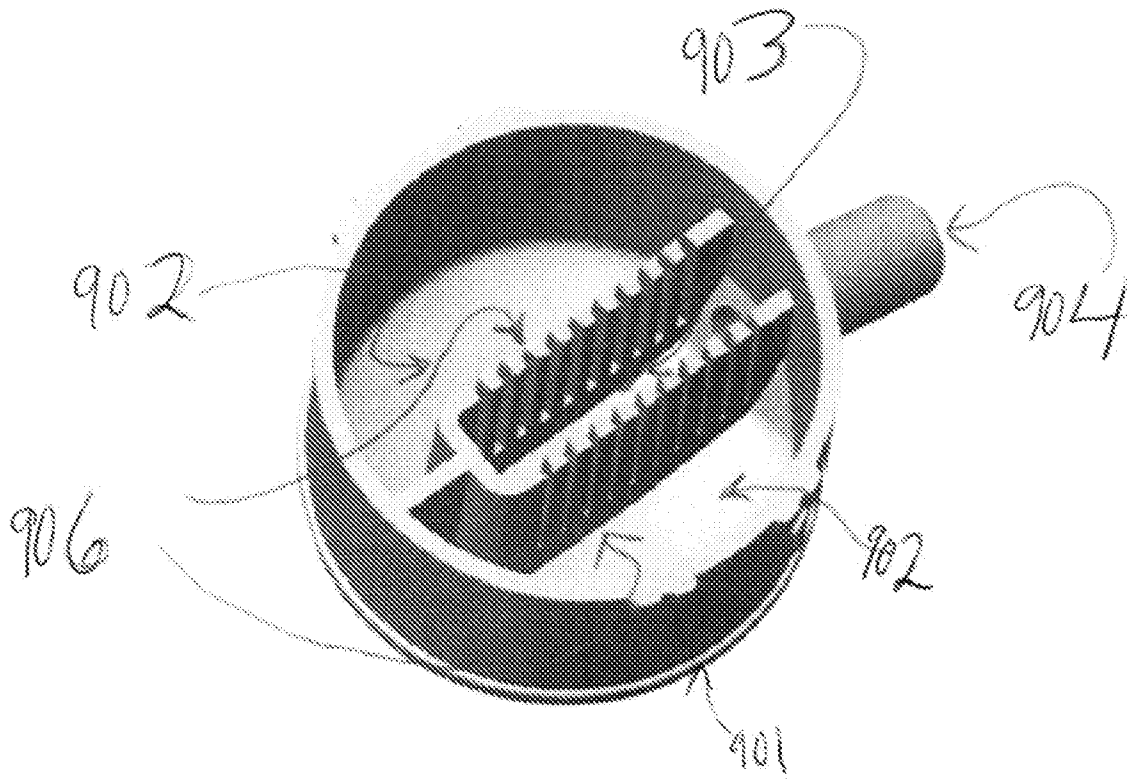

Fig. 15C

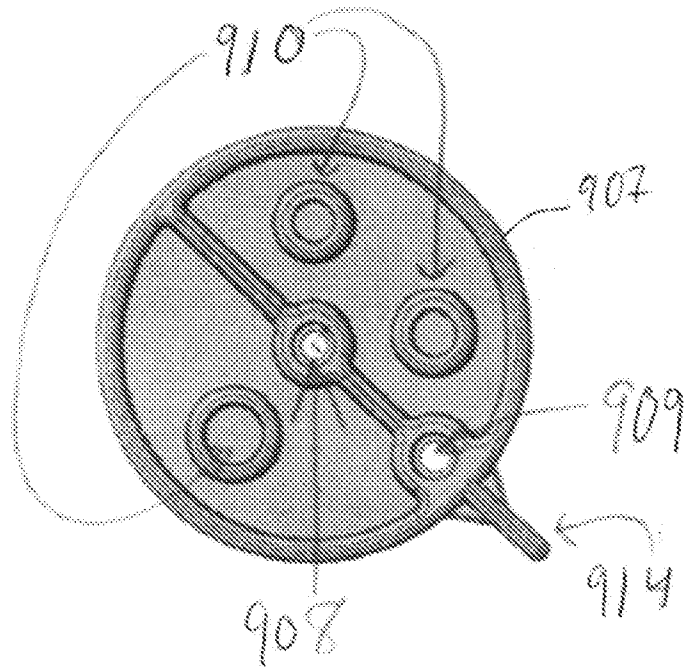

Fig. 15D

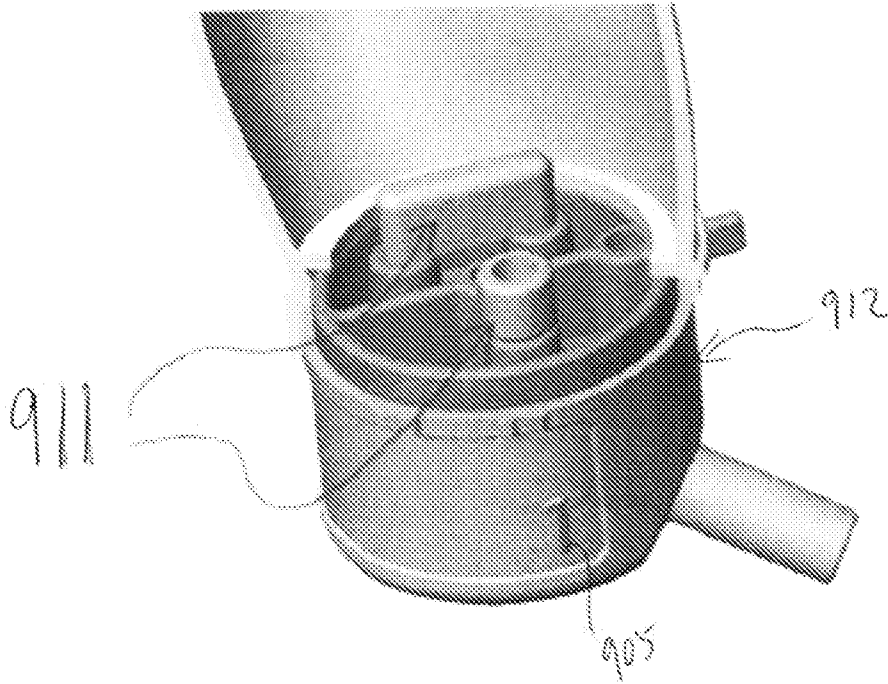

Fig. 15E

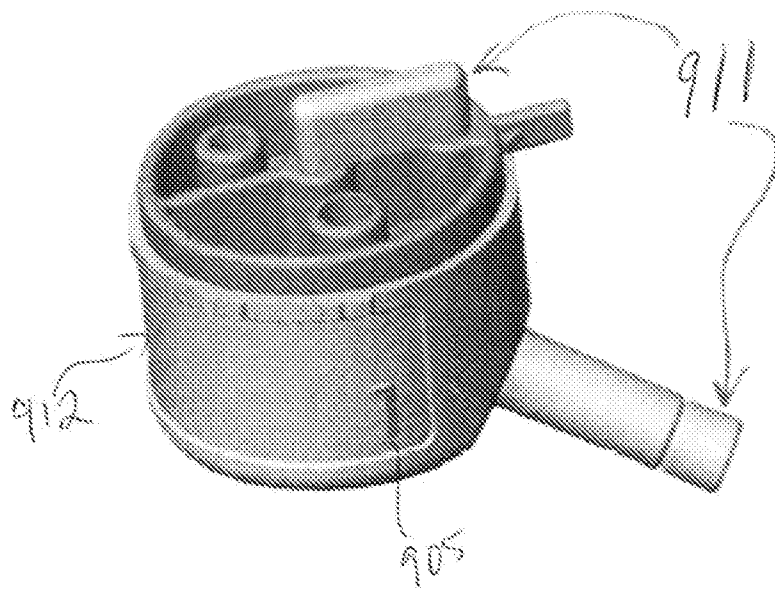

Fig. 15F