

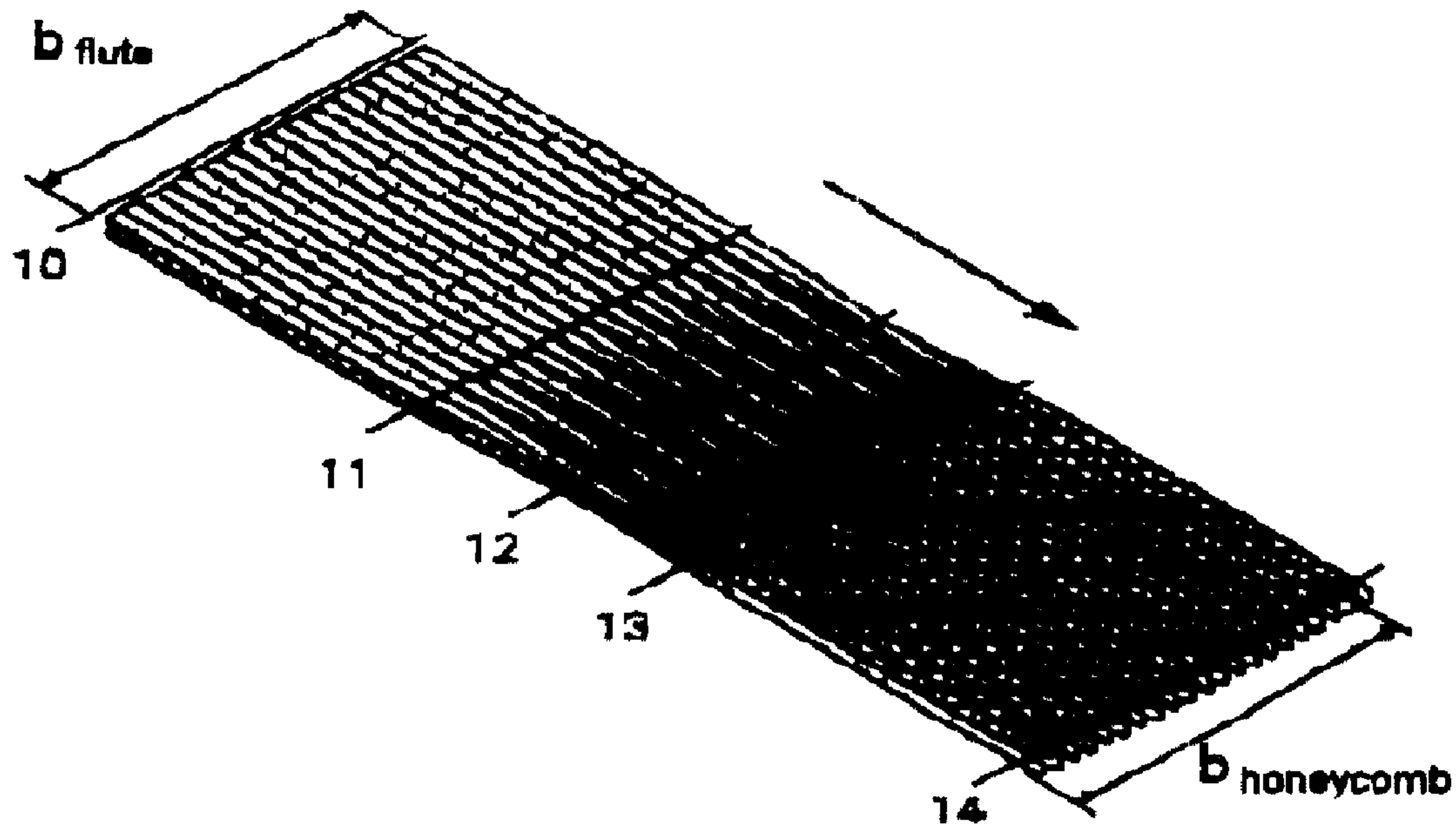

(86) Date de dépôt PCT/PCT Filing Date: 2000/03/25
 (87) Date publication PCT/PCT Publication Date: 2000/10/05
 (45) Date de délivrance/Issue Date: 2008/07/22
 (85) Entrée phase nationale/National Entry: 2002/04/15
 (86) N° demande PCT/PCT Application No.: EP 2000/002646
 (87) N° publication PCT/PCT Publication No.: 2000/058080
 (30) Priorité/Priority: 1999/03/26 (DE199 13 830.3)

(51) Cl.Int./Int.Cl. *B31D 3/00* (2006.01),
B31D 3/02 (2006.01), *B21D 47/00* (2006.01)
 (72) Inventeurs/Inventors:
PFLUG, JOCHEN, DE;
VERPOEST, IGNACE, BE
 (73) Propriétaires/Owners:
K.U. LEUVEN RESEARCH & DEVELOPMENT, BE;
PFLUG, JOCHEN, DE
 (74) Agent: SMART & BIGGAR

(54) Titre : STRUCTURE EN NID D'ABEILLE PLISSEE, EN CARTON ONDULE, ET PROCEDE ET DISPOSITIF DE FABRICATION ASSOCIES
 (54) Title: FOLDED HONEYCOMB MADE OF CORRUGATED CARDBOARD, PROCESS AND APPARATUS FOR ITS PRODUCTION



(57) **Abrégé/Abstract:**

The invention relates to a folded honeycomb structure and to a method and device for producing said folded honeycomb structure from a corrugated core web. The folded honeycomb structure has a number of adjacent corrugated core strips which lie in one plane and are interconnected by cover layer strips. Said cover layer strips are folded about 180° and are perpendicular to said plane. According to the inventive method for producing the folded honeycomb structure, interconnected corrugated core strips are produced first by making a number of longitudinal scores in a corrugated core web. These corrugated core strips are then alternately rotated through 90° respectively so that the cover layer strips fold and the folded honeycomb structure is formed. The device corresponding to this method consists of a number of rotating blades for making the longitudinal scores and a number of guiding elements for rotating the interconnecting corrugated core strips.

PCT
WELTORGANISATION FÜR GEISTIGES EIGENTUM
Internationales Büro

INTERNATIONALE ANMELDUNG VERÖFFENTLICHT NACH DEM VERTRAG ÜBER DIE
INTERNATIONALE ZUSAMMENARBEIT AUF DEM GEBIET DES PATENTWESENS (PCT)



<p>(51) Internationale Patentklassifikation ⁷ : B31D 3/00, B21D 47/00</p>	A1	<p>(11) Internationale Veröffentlichungsnummer: WO 00/58080</p> <p>(43) Internationales Veröffentlichungsdatum: 5. Oktober 2000 (05.10.00)</p>
<p>(21) Internationales Aktenzeichen: PCT/EP00/02646</p> <p>(22) Internationales Anmeldedatum: 25. März 2000 (25.03.00)</p> <p>(30) Prioritätsdaten: 199 13 830.3 26. März 1999 (26.03.99) DE</p> <p>(71) Anmelder (für alle Bestimmungsstaaten ausser US): K.U. LEUVEN RESEARCH & DEVELOPMENT [BE/BE]; Groot Begijnhof, Benedenstraat 59, B-3000 Leuven (BE).</p> <p>(72) Erfinder; und (75) Erfinder/Anmelder (nur für US): PFLUG, Jochen [DE/DE]; Ernst-Göbel-Strasse 35, D-65207 Wiesbaden (DE).</p> <p>(74) Anwälte: BIRD, William, E. usw.; Bird Goën & Co., Vilvoordsebaan 92, B-3020 Winksele (BE).</p>	<p>(81) Bestimmungsstaaten: AE, AL, AM, AT, AU, AZ, BA, BB, BG, BR, BY, CA, CH, CN, CR, CU, CZ, DE, DK, DM, EE, ES, FI, GB, GD, GE, GH, GM, HR, HU, ID, IL, IN, IS, JP, KE, KG, KP, KR, KZ, LC, LK, LR, LS, LT, LU, LV, MA, MD, MG, MK, MN, MW, MX, NO, NZ, PL, PT, RO, RU, SD, SE, SG, SI, SK, SL, TJ, TM, TR, TT, TZ, UA, UG, US, UZ, VN, YU, ZA, ZW, ARIPO Patent (GH, GM, KE, LS, MW, SD, SL, SZ, TZ, UG, ZW), eurasisches Patent (AM, AZ, BY, KG, KZ, MD, RU, TJ, TM), europäisches Patent (AT, BE, CH, CY, DE, DK, ES, FI, FR, GB, GR, IE, IT, LU, MC, NL, PT, SE), OAPI Patent (BF, BJ, CF, CG, CI, CM, GA, GN, GW, ML, MR, NE, SN, TD, TG).</p> <p>Veröffentlicht <i>Mit internationalem Recherchenbericht. Vor Ablauf der für Änderungen der Ansprüche zugelassenen Frist; Veröffentlichung wird wiederholt falls Änderungen eintreffen.</i></p>	

(54) **Title:** FOLDED HONEYCOMB STRUCTURE CONSISTING OF CORRUGATED PAPERBOARD AND METHOD AND DEVICE FOR PRODUCING THE SAME

(54) **Bezeichnung:** FALTWABE AUS WELLPAPPE, VERFAHREN UND VORRICHTUNG ZU DEREN HERSTELLUNG

(57) **Abstract**

The invention relates to a folded honeycomb structure and to a method and device for producing said folded honeycomb structure from a corrugated core web. The folded honeycomb structure has a number of adjacent corrugated core strips which lie in one plane and are interconnected by cover layer strips. Said cover layer strips are folded about 180° and are perpendicular to said plane. According to the inventive method for producing the folded honeycomb structure, interconnected corrugated core strips are produced first by making a number of longitudinal scores in a corrugated core web. These corrugated core strips are then alternately rotated through 90° respectively so that the cover layer strips fold and the folded honeycomb structure is formed. The device corresponding to this method consists of a number of rotating blades for making the longitudinal scores and a number of guiding elements for rotating the interconnecting corrugated core strips.

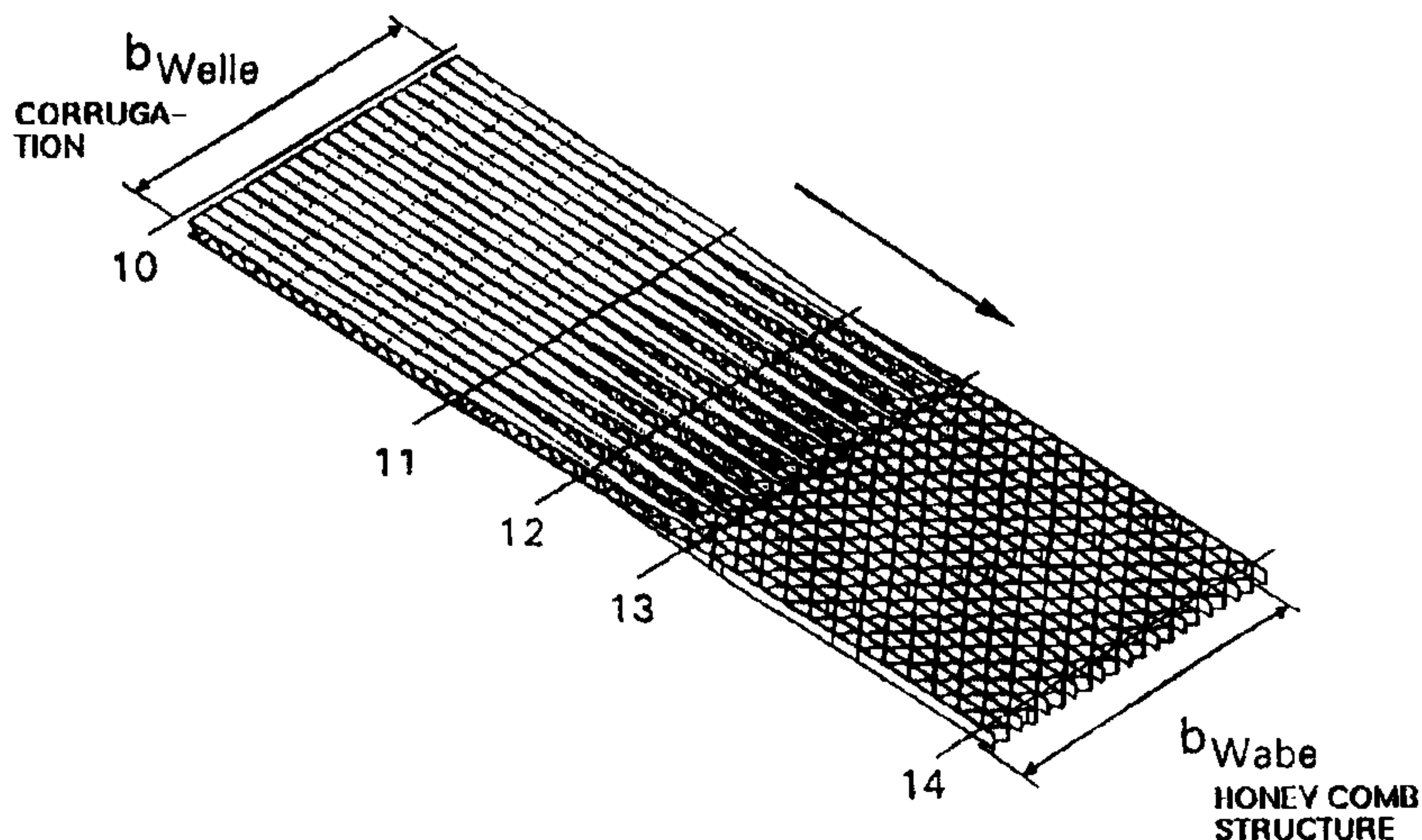

WO 00/58080

1/23

PCT/EP00/02646

Folded honeycomb made of corrugated cardboard, process
and apparatus for its production

5 The invention relates to honeycomb core layers such as
are used in sandwich materials for packaging and
structural applications, as well as to processes and
apparatus for producing these honeycomb cores.

10 In the aerospace industry, honeycomb cores have
preferably been used for many decades as core material
for sandwich panels and boards that are resistant to
buckling and bending. These honeycomb cores, which are
mostly hexagonal or over-expanded, consist
15 predominantly of aluminum or phenolic-resin impregnated
aramide fiber paper and are usually produced in the
expansion process. A sandwich structure having two,
usually adhesively bonded cover layers provides
extremely high stiffness/weight and strength/weight
20 ratios. The interest expressed by other large branches
of industry in lightweight sandwich core materials with
good weight-specific material characteristics is
continually growing, so that in the meantime more than
half the honeycomb core materials are being used in
other sectors.

25 The use of honeycombs for packaging, in automobile and
comparable markets requires fast and continuous
production of the honeycomb core layer, in order that a
product which is competitive with corrugated board and
30 other inexpensive materials can be produced.

A sandwich with a honeycomb core has high specific
compressive strengths in the material plane, because of
the optimum, virtually orientation independent, support
35 of the covering layers. As compared with a sandwich
with a corrugated core (for example corrugated
cardboard), better edge compression resistances and

WO 00/58080

2/23

PCT/EP00/02646

flexural rigidity values can be achieved, in particular in the machine direction. As a result, significant savings in weight and material are possible. The pressure characteristics are also considerably better at right angles to the plane of the material because of the perpendicular, mutually supporting cell walls. In addition, a sandwich with a honeycomb core has a better surface quality, which is important in particular for printing packaging materials. Because of these advantages and the increase in demand for inexpensive sandwich cores, numerous efforts have been taken in the past to reduce the high production costs of honeycomb cores.

Many processes are known in which individual material strips or a continuous material web is adhesively bonded at alternating locations and then expanded (US 4,500,380 Bova, DE 196 09 309 Hering, US 4,992,132 Schmidlin, US 5,334,276 Meier). Such processes are already used for the partially automated production of paper honeycombs with cell sizes above about 10 mm for internal packaging, edge and corner elements and also for pallets. The necessary forces and the material stresses during expansion place high requirements on the adhesive and the adhesive bonding of the cell walls. By means of pre-embossing the fold lines, these forces can certainly be reduced but the regularity of the honeycomb geometry suffers from the expansion process, in particular in the case of paper honeycombs with small cell sizes. The internal stresses and the necessary expansion forces are increased considerably in the case of smaller cell sizes. For this reason, these processes are increasingly problematic for smaller cell sizes and more difficult to automate. In addition, the production speed is limited by the required cross-cutting of the web.

WO 00/58080

3/23

PCT/EP00/02646

Likewise, many processes are known in which individual, corrugated or trapezoidal material webs or strips are adhesively bonded in an offset manner (US 3,887,418 Jurisich, US 5,217,556 Fell, US 5,399,221 Casella, 5 US 5,324,465 Duffy). Technical implementation to obtain a continuous process with a high production speed is difficult in the case of these processes, because of the necessary positioning and handling of the individual material webs.

10

Furthermore, processes are known in which corrugated cardboard is processed to form honeycomb cores. In one process, corrugated cardboard is used in the cell walls of honeycomb cores (US 4,948,445 Hess). In this case, 15 individual sheets of corrugated cardboard with flutes running in the production direction are supplied and short cross-cuts going through the entire thickness of the corrugated cardboard are introduced. Therefore, following folding in the production direction and 20 expansion, corrugated cores with relatively large cell sizes and relatively thick cell walls are produced. The process is principally the same as the expansion process with a continuous material web.

25 Furthermore, honeycombs and processes are known in which a corrugated cardboard web (US 3,912,573 Kunz) or an individual corrugated web (WO 91/00803 Kunz) with the flutes transverse to the production direction is cut into strips. After the web has been cut up, a 30 honeycomb core layer is then produced by bonding the individual strips adhesively to one another. This process requires a certain size of the individual strips or special positioning tapes, in order that their handling is still ensured. Because of the size of 35 the strips, the web width is reduced considerably following the rotation of the strips. In order not to obtain too small a width of the honeycomb core layer,

WO 00/58080

4/23

PCT/EP00/02646

the strips are cut off in a further production step and adhesively bonded to form a honeycomb block, which is then conveyed considerably more slowly transversely to the production direction. For small honeycomb heights, 5 this honeycomb block has to be cut up, if appropriate. The honeycombs produced by such a process also have individual straight strips between individual corrugated or trapezoidally shaped cell wall strips. Such reinforced honeycombs are also known from manual 10 production via a block (WO 95/10412 Darfler). There, the individual flat layers are placed between the individual corrugated layers and adhesively bonded to them.

15 Honeycombs and processes for their production are also known in which a continuous material web, following the introduction of cuts, is initially corrugated or formed trapezoidally before the connected cell walls are folded against one another and adhesively bonded 20 (WO 97/03816 Pflug). In order to achieve a saving in material in packaging applications, in particular as compared with corrugated cardboard, a very lightweight paper (40 g/m^2 to 80 g/m^2) is to be preferred. When corrugating these low grammages, it is advantageous to 25 stabilize the flute immediately after it has been formed by bonding it onto a web. In particular, in the case of corrugation transversely to the production direction, as is common in the production of corrugated cardboard at speeds up to 350 m/min, a covering layer 30 (a liner, as it is known) has to be bonded on immediately. The corrugated web on its own cannot absorb the tensile stress necessary for the rapid conveyance of the material web.

35 Furthermore, processes and apparatus are known for introducing slits into corrugated cardboards (US 5,690,601 Cummings). These slits are made along the

77770-33

5/23

flutes of individual sheets of corrugated cardboard (in the transverse direction to the actual production direction of the corrugated cardboard) in order to permit a defined folding. In this process, folding is carried out towards
5 the cut so that the latter is closed.

Embodiments of the invention are based on the object of specifying a honeycomb core layer, a process and an apparatus which permit the continuous production of honeycombs with relatively small cell sizes at a production
10 speed comparable with the production of corrugated cardboard. In addition, good surface quality as well as reliable and quick attachment of the covering layers is desired.

According to one aspect of the invention, there is
15 provided a folded honeycomb, comprising a large number of core strips which lie beside one another and in one plane and each comprises a corrugated or trapezoidal core having flutes with a corrugated or trapezoidal cross-section, respectively and with at least one cover layer, the cover
20 layers of the core strips being arranged parallel to one another and transversely with respect to the one plane, and the longitudinal direction of the flutes of the core extending, for each core strip, transversely with respect to the core strip and also with respect to the one plane, and
25 the core strips being connected to one another, wherein for at least each second core strip, a cover layer of one core strip is formed in one piece with the cover layer of one of the adjacent core strips and is connected to the cover layer of said adjacent core strip via a connection formed by a
30 fold of 180° in the cover layer, and the connections between adjacent core strips are arranged alternately on one side and the other side of the plane of the folded honeycomb.

77770-33

5a/23

According to another aspect of the invention, there is provided a process for the continuous production of a folded honeycomb, comprising the following steps:

a) forming connected core strips which lie one beside the other and lie in one plane, the core strips comprising a corrugated or a trapezoidal core having flutes with a corrugated or trapezoidal cross-section, respectively and at least one cover layer, the cover layers of the core strips being arranged parallel to one another and parallel with respect to the one plane, and the longitudinal direction of the flutes of the core extending, for each core strip, transversely with respect to the core strip and parallel with respect to the one plane, the core strips being connected to one another and, for at least each second core strip, the cover layer of one core strip being connected to the cover layer of an adjacent core strip; and

b) rotating the connected core strips through about 90° in relation to one another, as a result of which the cover layers of the core strips are folded through about 180° at lines connecting the core strips to thereby bring the longitudinal direction of the flutes of the core to extend, for each core strip, transversely with respect to the core strip and transversely with respect to the one plane.

According to another aspect of the invention, there is provided a system for producing a folded honeycomb, comprising: a) a first apparatus for forming connected core strips which lie beside one another and in one plane, each comprising a corrugated or a trapezoidal core with flutes having a corrugated or trapezoidal cross-section, respectively and with at least one cover layer, the cover layers of the core strips being arranged parallel to one another and parallel with respect to the one plane, and the longitudinal direction of the flutes of the core extending,

77770-33

5b/23

for each core strip, transversely with respect to the core strip and parallel with respect to the one plane, the core strips being connected to one another and, in at least each second core strip a cover layer of one core strip being
5 connected to the cover layer of one of the adjacent core strips; and b) a second apparatus for rotating the connected core strips through about 90° with respect to one another, as a result of which the cover layers are folded through about 180° at lines connecting the core strips to thereby
10 bring the longitudinal direction of the flutes of the core to extend, for each core strip, transversely with respect to the core strip and transversely with respect to the one plane.

According to another aspect of the invention,
15 there is provided a plurality of core strips which lie one beside the other, are connected to each other and lie in one plane and which each have a corrugated or a trapezoidal core with flutes having a corrugated or trapezoidal cross-section respectively and at least one cover layer, the cover layers
20 of the core strips being parallel to one another, and the longitudinal direction of the flutes of the core, for each core strip extending transversely with respect to the core strip and parallel to the one plane, and the core strips being connected to one another, wherein for at least each
25 second core strip, the cover layer of one core strip is formed in one piece with the cover layer of one of the adjacent core strips and can be connected to the cover layer of said adjacent core strip by being folded through 180° to form a folded honeycomb, so that the connections between
30 adjacent core strips are arranged alternately on one side and the other side of the folded honeycomb to thereby bring the longitudinal direction of the flutes of the core to extend, for each core strip, transversely with respect to

77770-33

5c/23

the core strip and transversely with respect to the one plane.

This latter aspect of the invention provides an intermediate product from which the folded honeycomb can be
5 formed.

In embodiments of the invention, a corrugated or trapezoidal material web having at least one, but in some embodiments, having two, covering layers is supplied. This can be corrugated cardboard or else a plastic fibre
10 composite or metal corrugated core board. In addition, a web having a plurality of corrugated cores, for example a double-flute corrugated cardboard (BC flute, AA flute) can be used. The cover layers may also consist of very thin material (weight per unit area between 60 g/m^2 and 100 g/m^2)
15 and the corrugated core layer consists of material up to twice the thickness since the covering layers in the preferred variant of the folded honeycomb are laid doubled. In this case, very low demands are placed on the quality of the cover layers, and also on the thickness tolerance and
20 surface quality of the corrugated core web, since these factors have little influence on the surface quality of the end product.

WO 00/58080

6/23

PCT/EP00/02646

The thickness of the corrugated cardboard web determines the size of the honeycomb cells. In order to support the cover layers, cell sizes of 4.7 mm (A flute) or, at very low weights per unit area, 3.6 mm (C flute) are adequate since the flat corrugated core cover layer strips provide an additional support and reduce the risk of dimpling of the cover layers in the cells. However, corrugated cores with smaller and larger cell sizes can also be produced from corrugated core webs with smaller and larger heights of the flute (e.g. K flute).

According to one embodiment of the invention, the multi-layer web is firstly provided in the conveying direction with a large number of continuous fold lines on the underside and the upper side. The fold lines can be introduced, for example, by means of pressing or longitudinal cutting of the web. The cuts do not quite cut through the web in the thickness direction but in each case leave a continuous cover layer (or the cover layer and the peaks of the flutes). The cuts on the upper side are in this case located as accurately as possible halfway between the cuts on the underside. The irregularities in the cover layers, which are normal in corrugated cardboard, and the different cutting forces between the peaks of the flutes can lead to the cover layer being partly or wholly cut through at individual points. This is entirely desirable, provided that the corrugated core strips still remain connected in the transverse direction. The necessary folding force can be reduced by this slight cutting or perforation of the cover layers or an additional pre-embossing of the fold lines. The corrugated core strips can also first be completely cut through and, at the same time or immediately thereafter, adhesively bonded together by means of adhesive foils. This material may be easier to

WO 00/58080

7/23

PCT/EP00/02646

bend and to fold, as compared with the material of the web. Therefore, the combination of words "formed in one piece" not only includes corrugated strips which are connected to one another by a cover layer, but also
5 separate corrugated strips which are connected to one another by adhesive foil. The ratio between the width and the height of the connected corrugated core strips is preferably in the range from 0.5 to 2.0.

10 The connected corrugated core strips are then in each case rotated through 90° in such a way that the cuts open and the connected cover layers of adjacent strips are folded through 180° . Since the strips are connected, no alignment in the thickness or
15 longitudinal direction is necessary. The strips lie planar next to each other with the connected cover layers and form the folded honeycomb. They can be adhesively bonded, joined in any other way or joined by the new cover layers only when the latter are bonded
20 on. The application of the adhesive can then be carried out by means of rollers, nozzles or brushes, an application which constantly applies a relatively low amount of adhesive being preferred. When use is made of a corrugated core web having two cover layers, the
25 corrugated core strips are significantly more stable than only with one cover layer, and can be adhesively bonded with some pressure. Possible deformations of the corrugated core, which often impair the surface quality in the production of corrugated cardboards, takes place
30 here in the width direction and has no influence on the surface quality and thickness tolerance of the folded honeycomb.

The flat corrugated core cover layer strips, which are
35 vertical in the honeycomb, are able to accommodate the tensile stresses in the production direction and permit a fast transport of the material web. They subsequently

WO 00/58080

8/23

PCT/EP00/02646

increase the shear and compression characteristics of the honeycomb, so that all the material of the corrugated cardboard is utilized in the honeycomb core folded from it.

5

In order to produce a honeycomb board material, new covering layers can be adhesively bonded continuously onto the honeycomb core layer immediately after the honeycomb production. In this case, the high
10 compressive strength of the honeycomb is very useful. Good attachment of the cover layers to the honeycomb can be achieved by slight defibering of the edges during the introduction of the longitudinal cuts. In addition to the edges of the corrugated core layer, the
15 small side faces of the folded corrugated core cover layer strips are additionally available for the attachment of the cover layers.

An embodiment of the honeycomb core layer, the process and the apparatus is described by using the drawings, in which

Figure 1 shows the corrugated core web and the position of the longitudinal slits in plan
25 view and side view,

Figure 2 shows the position of the longitudinal slits in the corrugated core web in front view,

30 Figure 3 shows the slightly folded coherent corrugated core strips,

Figure 4 shows the connected corrugated core strips folded through 30°,

35

Figure 5 shows the connected corrugated core strips folded through 60°,

WO 00/58080

9/23

PCT/EP00/02646

Figure 6 shows the almost completely folded coherent corrugated core strips,

5 Figure 7 shows a perspective illustration of the slightly folded corrugated core web,

Figure 8 shows a perspective illustration of the corrugated core web folded through 30°,

10

Figure 9 shows a perspective illustration of the corrugated core web folded through 60°,

Figure 10 shows a perspective illustration of the almost completely folded honeycomb of corrugated cardboard,

15

Figure 11 shows the process for producing the folded honeycomb from corrugated cardboard in plan view,

20

Figure 12 shows a perspective illustration of the process for producing the folded honeycomb from corrugated cardboard,

25

Figure 13 shows the leading of the material web out of the plane of the web in side view,

Figure 14 shows the still flat corrugated core web in front view,

30

Figure 15 shows the deformation out of the plane of the web in a corrugated core web folded through 5°,

35

WO 00/58080

10/23

PCT/EP00/02646

Figure 16 shows the deformation out of the plane of the web in a corrugated core web folded through 45°,

5 Figure 17 shows the deformation out of the plane of the web in the case of three-stage rotation of each third corrugated core strip,

10 Figure 18 shows the apparatus for introducing the longitudinal slits for producing the folded honeycomb in front view,

15 Figure 19 shows the apparatus for the variable introduction of the longitudinal slits in front view,

20 Figure 20 shows a section of the apparatus for rotating and folding together the connected corrugated core strips to produce the folded honeycomb from corrugated cardboard,

25 Figure 21 shows a section of the apparatus for the variable rotation and folding together of the connected corrugated core strips.

30 Figure 1 shows the supplied corrugated core web with the flutes transverse to the production direction, and the position of the longitudinal slits in plan view and side view. The corrugated core web can be based on plastic, fabric, fibre composite material, paper, paperboard or similar materials. The corrugated core strips 1 are each bounded by two slits 2 and 3. By means of these cuts, which do not quite cut through the material web in the thickness direction, the corrugated core web is alternately cut into from above and below. 35 The remaining material (a cover layer and/or the peaks of the flutes of the corrugated core) are later folded

WO 00/58080

11/23

PCT/EP00/02646

at this point around the fold lines 4 and 5. Figure 2 shows the position of the longitudinal slits and the fold lines in front view. The ratio between the width and the height of each corrugated core strip is preferably in the range from 0.5 to 2.

Figures 3 to 6 show the folding of the connected corrugated core strips step by step in front view. An adhesive 6 for packaging purposes, preferably based on starch or PVA, can be applied to the corrugated core cover layer strips before they are folded. The adhesive can be applied to the entire surface or only at the point where the peaks of the flutes or valleys of the flutes meet the adjacent corrugated core strips. Figures 7 to 10 show the same intermediate production steps in a perspective illustration.

Figure 11 shows the process for producing the folded honeycomb from corrugated cardboard in plan view. The positions of the individual process steps are shown in Figure 12. Firstly, at position 10, the longitudinal slits are introduced into the material web. Then, from 11 to 13, the material strips are rotated. Here, an adhesive can optionally be introduced first during the rotation (for example at 12). At 14, covering layers can then be applied to the folded honeycomb.

In the continuous process, torsional stresses result from the rotation of the connected corrugated core strips. These stresses are relatively low, because of the low torsional rigidity of the thin, narrow strips. The length of this process step can therefore be relatively short (< 0.5 m), if there is no change in the web width. The ratio between the thickness of the corrugated core web and the thickness of the honeycomb core layer necessarily corresponds to the ratio between

WO 00/58080

12/23

PCT/EP00/02646

the widths of the two material webs ($b_{\text{honeycomb}} = b_{\text{corrugation}} \cdot t_{\text{honeycomb}}/t_{\text{corrugation}}$).

The corrugated core thickness ($t_{\text{corrugation}}$) should preferably be selected to be equal to the honeycomb core thickness ($t_{\text{honeycomb}}$), in order that a constant machine width results ($b_{\text{honeycomb}} = b_{\text{corrugation}}$). However, during the rotation of the material strips, a maximum width of the web is in any case reached with

10 $b_{\text{max}} = b_{\text{corrugated}} \cdot \sqrt{(t_{\text{corrugated}}^2 + t_{\text{honeycomb}}^2)} / t_{\text{honeycomb}}$. With the same material thickness $t_{\text{corrugation}} = t_{\text{honeycomb}}$, the width change would be $b_{\text{max}} = 1.41 \cdot b_{\text{corrugation}}$. This change in the web width can be prevented by guiding the material strips briefly out of the plane of the web.

15

Figure 13 shows the guidance of the material web out of the plane of the web in side view. The connected corrugated core strips can be bent slightly during the 90° twist. However, bending the twisted corrugated core strips requires a greater length of the twisting

20 region. It is therefore expedient to make the web slightly wavy over the width in order in this way to limit the deformations from the plane of the web. Figures 14 to 16 show the individual steps during a possible deformation of the connected corrugated core

25 strips out of the plane of the web in order to avoid the change in web width.

In addition, the change in width can be reduced considerably if the corrugated core strips are rotated

30 one after another. In this case, it is particularly advantageous to rotate first of all each third corrugated core strip first. In this way, all the corrugated core strips can be rotated in three stages

35 without any noticeable change in width resulting. Figure 17 shows the three-stage rotation of each third corrugated core strip and the resulting slight

WO 00/58080

13/23

PCT/EP00/02646

deformations out of the plane of the web, in individual front views. Individual corrugated core strips or a number of corrugated core strips can also be rotated one after another in a different sequence in order to
5 limit the change in width.

Nevertheless, a reduction in the web width during the production of honeycomb core layers with a greater thickness ($t_{\text{honeycomb}} > t_{\text{corrugation}}$) and an increase in the web
10 width during the production of smaller thicknesses ($t_{\text{honeycomb}} < t_{\text{corrugation}}$) may possibly be advantageous up to a certain extent, for reasons concerning the flexibility of the system. The ratio between the thickness of the corrugated core web ($t_{\text{corrugation}}$) and the thickness of the
15 honeycomb core layer ($t_{\text{honeycomb}}$) is in this case preferably between 0.5 and 2. Figure 18 shows an apparatus for introducing the longitudinal slits. This apparatus can comprise simple longitudinal cutting knives 20, which rotate on an upper 21 and a lower
20 shaft 22 or on a large number of separate shafts. The distance between the upper and lower cutting knives in relation to one another and among each other should be as uniform as possible, in order to achieve a high cutting accuracy and therefore a very constant
25 honeycomb core thickness. In addition, the material web should be guided as exactly as possible (for example by means of rolls) in order that an exact depth of the slits is achieved. The rapid exact cutting of corrugated cores in the production direction is already
30 carried out in corrugated cardboard production. In addition to the preferred use of rotating knives, cutting with stationary knives is also conceivable. The connected corrugated core strips form a relatively stable web, and therefore the corrugated core web can
35 be conveyed by using rolls or belts downstream of the longitudinal cutting knives, following the introduction of the slits.

WO 00/58080

14/23

PCT/EP00/02646

Figure 19 shows a variable apparatus 24 for introducing the longitudinal slits. By means of uniform adjustment of the distances between the individual cutting knives 5 20 in the width direction, honeycomb core layers of different thickness can be produced. In addition, the rapid replacement of the complete cutting rolls (for example using turret systems, as they are known) is also conceivable.

10

Figure 20 shows an apparatus for rotating and folding together the connected corrugated core strips. The apparatus may comprise simple stationary guides 23, rotating rolls or transport belts. The geometry of 15 these guides determines how the connected corrugated core strips are rotated during transport and folded against one another. Thereby, either sequential rotation, in which the result is very slight step-like waviness over the width, or simultaneous rotation with 20 a larger waviness over the width is possible.

Figure 21 shows a variable apparatus for the simultaneous rotation and folding together of the connected corrugated core strips with waviness over the 25 width. Figure 17 shows how the guides of the individual material strips have to guide each third corrugated core strip in three stages as they are rotated. In the case of this variant, it is advantageous that it is sufficient to lead the respective non-rotating two 30 corrugated core strips upwardly and downwardly, in order to rotate the respective corrugated core strip located between them through 90°.

This folded honeycomb made of corrugated cardboard, the 35 process described and the apparatus permit the production of a honeycomb material which is significantly superior to the corrugated cardboard in

WO 00/58080

15/23

PCT/EP00/02646

all material characteristics. The honeycomb core layer thickness should preferably be more than 4 mm, since the material savings as compared with corrugated cardboard with two corrugated cores lying one above
5 another are particularly large. However, even with lower heights, the honeycomb provides considerably better material characteristics. The material can be produced from the same, even if lighter papers (kraft-liner or testliner) and the conventional adhesive based
10 on starch or PVA with manufacturing equipment which, in terms of significant components, is equivalent to the widely developed corrugated cardboard manufacturing equipment. The two additional process steps (introduction of the longitudinal slits and folding the
15 connected corrugated cardboard strips) can be carried out by the simple apparatus described and do not reduce the production speed.

Using the above-described adjustable longitudinal
20 cutting and guidance devices and the exchange, common in the corrugated cardboard industry, of the rolls and components, a manufacturing equipment for single-flute corrugated cardboard is able to produce folded honeycombs of different thicknesses very flexibly. The
25 production costs are expected to be lower than those in the production of two-layer corrugated cardboards. In addition, the production speed on a honeycomb cardboard production manufacturing equipment based on a single-flute corrugated cardboard manufacturing equipment will
30 probably be greater than the double-flute corrugated cardboard manufacturing equipment which are common nowadays.

During the production of folded honeycombs from
35 corrugated cardboard, the gluing of the covering layers can be carried out in the same production line, directly after the finishing of the core layer, and for

WO 00/58080

16/23

PCT/EP00/02646

the further processing of the honeycomb cardboard, the cutting, punching and printing machines which are common in the corrugated cardboard processing industry can be used.

5

As compared with the corrugated cardboard, honeycomb cardboard has significantly better compressive strengths in the plane of the material (edge compression resistance, ECT), in particular in the production direction (machine direction). In addition, at right angles to the plane of the material (flat compression resistance, FCT), it provides significantly improved compressive characteristics and a greater absorption of shock energy. The possible savings in weight and material, the direction-independent strengths and the better surface quality, and also the small expenditure for the additional production steps, permit the expectation that the folded honeycomb cardboard made of corrugated cardboard is capable of competing with corrugated cardboard.

In addition, the folded honeycomb can be further processed in various ways to form sandwich components, without cover layers being laminated on. The honeycomb cells can additionally be filled with a foam or similar material for the purpose of improved acoustic and thermal insulation. Moreover, the honeycomb cell walls can be impregnated or coated by means of a dipping bath or by spraying. The good material characteristics and the low production costs permit the expectation that this material, in addition to packaging applications, will also find applications in other sectors, such as in inner cladding components for vehicles, in furniture, floor coverings and wall coverings, and so on.

35

WO 00/58080

17/23

PCT/EP00/02646

The advantages of the folded honeycomb according to the invention are:

- 5 a) improved printability as a result of better surface quality,
- b) improved mechanical characteristics, for example flat compression resistance and edge compression resistance, bending strength, flexural rigidity,
- 10 c) low weight with the same mechanical characteristics,
- d) good impact resistance and mechanical characteristics after an impact or shock,
- e) environmental friendliness, for example 20 to 25% less raw materials are used and the folded
15 honeycomb finds application where hitherto non-reusable materials have been used.

77770-33

18/23

CLAIMS:

1. A folded honeycomb, comprising a large number of core strips which lie beside one another and in one plane and each comprises a corrugated or trapezoidal core having flutes with a corrugated or trapezoidal cross-section, respectively and with at least one cover layer, the cover layers of the core strips being arranged parallel to one another and transversely with respect to the one plane, and the longitudinal direction of the flutes of the core extending, for each core strip, transversely with respect to the core strip and also with respect to the one plane, and the core strips being connected to one another, wherein for at least each second core strip, a cover layer of one core strip is formed in one piece with the cover layer of one of the adjacent core strips and is connected to the cover layer of said adjacent core strip via a connection formed by a fold of 180° in the cover layer, and the connections between adjacent core strips are arranged alternately on one side and the other side of the plane of the folded honeycomb.
2. The folded honeycomb according to claim 1, wherein the ratio between the width and the height of each core strip lies in the range from 0.5 to 2.
3. The folded honeycomb according to claim 1 or 2, wherein the ratio between the weights per unit area of material making up the core and material making up the cover layer of each core strip lies in the range from 1 to 2.
4. The folded honeycomb according to any one of claims 1 to 3, wherein the cover layer of the corrugated or trapezoidal core of at least each second corrugated strip is wholly or partly connected over its entire area to the cover layer of the corrugated or trapezoidal core of at least one adjacent core strip.

77770-33

19/23

5. The folded honeycomb according to any one of claims 1 to 4, wherein each core strip has two cover layers and a corrugated or trapezoidal core arranged between them, and one cover layer of each core strip is formed in one piece with a cover layer of an adjacent core strip and is connected to the cover layer of said adjacent core strip via a fold of 180°, and the other cover layer is formed in one piece with a cover layer of another adjacent core strip and is connected to the cover layer of said other adjacent core strip via a fold of 180°.
- 10 6. The folded honeycomb according to any one of claims 1 to 5, wherein a cover layer is arranged at least on one side of a large number of core strips lying beside one another.
7. A process for the continuous production of a folded honeycomb, comprising the following steps:
- 15 a) forming connected core strips which lie one beside the other and lie in one plane, the core strips comprising a corrugated or a trapezoidal core having flutes with a corrugated or trapezoidal cross-section, respectively and at least one cover layer, the cover layers of the core strips being arranged parallel to one another and parallel with respect to the one plane, and the longitudinal direction of the flutes of the core extending, for each core strip, transversely with respect to the core strip and parallel with respect to the one plane, the core strips being connected to one another and, for at least each second core strip, the cover layer of one core strip being connected to the cover layer of an adjacent core strip; and
- 20 b) rotating the connected core strips through about 90° in relation to one another, as a result of which the cover layers of the core strips are folded through about 180° at lines connecting the core strips to thereby bring the longitudinal
- 25
- 30

77770-33

20/23

direction of the flutes of the core to extend, for each core strip, transversely with respect to the core strip and transversely with respect to the one plane.

8. The process according to claim 7, wherein the ratio
5 between the width and the height of each core strip lies in the range from 0.5 to 2.

9. The process according to claim 7 or 8, wherein the
ratio between the weights per unit area of material making up
the core and material making up the cover layer of each core
10 strip lies in the range from 1 to 2.

10. The process according to any one of claims 7 to 9,
wherein touching surfaces are firmly connected to one another.

11. The process according to claim 10, wherein the
touching surfaces are firmly connected to one another with
15 adhesive which is applied previously.

12. The process according to any one of claims 7 to 11,
wherein at least one cover sheet is laminated onto the folded
honeycomb.

13. The process according to any one of claims 7 to 12,
20 wherein the step of forming the connected core strips includes
cutting completely through a core web to form individual core
strips.

14. The process according to any one of claims 7 to 11,
wherein the step of forming the connected core strips includes
25 the longitudinal slitting of a core web to form connected core
strips.

15. A system for producing a folded honeycomb,
comprising:

77770-33

21/23

a) a first apparatus for forming connected core strips which lie beside one another and in one plane, each comprising a corrugated or a trapezoidal core with flutes having a corrugated or trapezoidal cross-section, respectively and with
5 at least one cover layer, the cover layers of the core strips being arranged parallel to one another and parallel with respect to the one plane, and the longitudinal direction of the flutes of the core extending, for each core strip, transversely with respect to the core strip and parallel with respect to the
10 one plane, the core strips being connected to one another and, in at least each second core strip a cover layer of one core strip being connected to the cover layer of one of the adjacent core strips; and

b) a second apparatus for rotating the connected core strips
15 through about 90° with respect to one another, as a result of which the cover layers are folded through about 180° at lines connecting the core strips to thereby bring the longitudinal direction of the flutes of the core to extend, for each core strip, transversely with respect to the core strip and
20 transversely with respect to the one plane.

16. The system according to claim 15, wherein the apparatus for forming the connected core strips includes an apparatus for cutting completely through a core web to form individual core strips.

25 17. The system according to claim 16, wherein the apparatus for cutting has adjusting devices for the variable setting of a distance of knives in the width direction, and the apparatus for rotating has adjusting devices for the variable setting of a distance of guide elements in the width direction.

30 18. The system according to claim 15, wherein the apparatus for forming the connected core strips includes an

77770-33

22/23

apparatus for longitudinal slitting of a core web to form connected core strips.

19. The system according to claim 18, wherein the apparatus for the longitudinal slitting of the core web has a plurality of rotating or stationary knives.

20. The system according to claim 19, wherein the apparatus for slitting has adjusting devices for the variable setting of a distance of the knives in the width direction, and the apparatus for rotating has adjusting devices for the variable setting of a distance of guide elements in the width direction.

21. The system according to claim 18, wherein the apparatus for slitting has adjusting devices for the variable setting of a distance of knives in the width direction, and the apparatus for rotating has adjusting devices for the variable setting of a distance of guide elements in the width direction.

22. The system according to any one of claims 15 to 21, wherein the ratio between the width and the height of each core strip lies in the range from 0.5 to 2.

23. The system according to any one of claims 15 to 22, wherein the ratio between the weights per unit area of material making up the core and material making up the cover layer of each core strip lies in the range from 1 to 2.

24. The system according to any one of claims 15 to 23, wherein the rotation apparatus has a longitudinal undulation and, as a result, leads the core strips out of the one plane for some time or leads them in such a way that individual core strips or a plurality of core strips are rotated one after another.

77770-33

23/23

25. The system according to any one of claims 15 to 24, wherein an apparatus for applying adhesive to the cover layers of the core strips is located upstream or in a region of the rotation of the core strips.

5 26. A plurality of core strips which lie one beside the other, are connected to each other and lie in one plane and which each have a corrugated or a trapezoidal core with flutes having a corrugated or trapezoidal cross-section respectively and at least one cover layer, the cover layers of the core
10 strips being parallel to one another, and the longitudinal direction of the flutes of the core, for each core strip extending transversely with respect to the core strip and parallel to the one plane, and the core strips being connected to one another, wherein for at least each second core strip,
15 the cover layer of one core strip is formed in one piece with the cover layer of one of the adjacent core strips and can be connected to the cover layer of said adjacent core strip by being folded through 180° to form a folded honeycomb, so that the connections between adjacent core strips are arranged
20 alternately on one side and the other side of the folded honeycomb to thereby bring the longitudinal direction of the flutes of the core to extend, for each core strip, transversely with respect to the core strip and transversely with respect to the one plane.

25 27. The plurality of core strips according to claim 26, wherein the ratio between the width and the height of each core strip lies in the range from 0.5 to 2.

SMART & BIGGAR
OTTAWA, CANADA

PATENT AGENTS

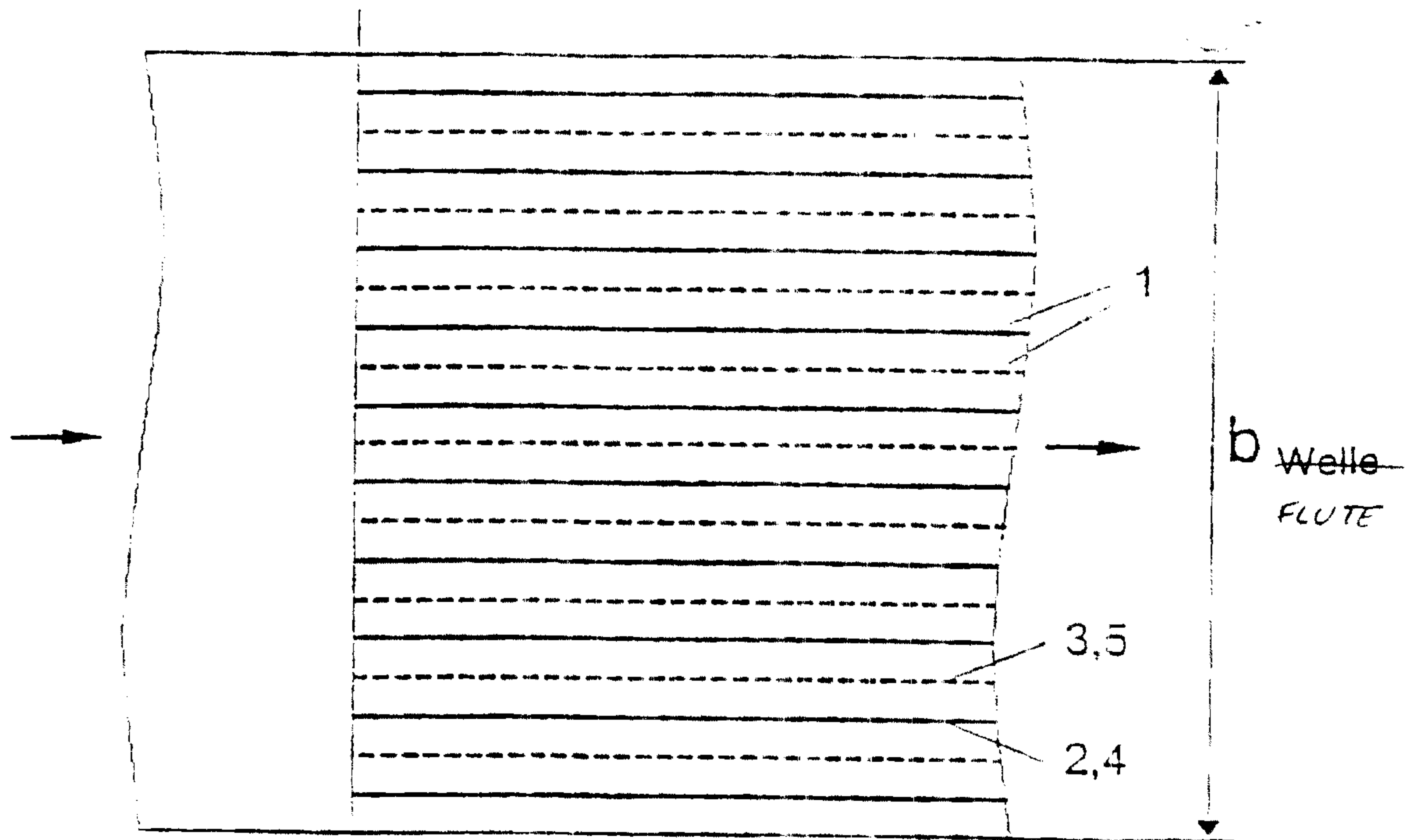
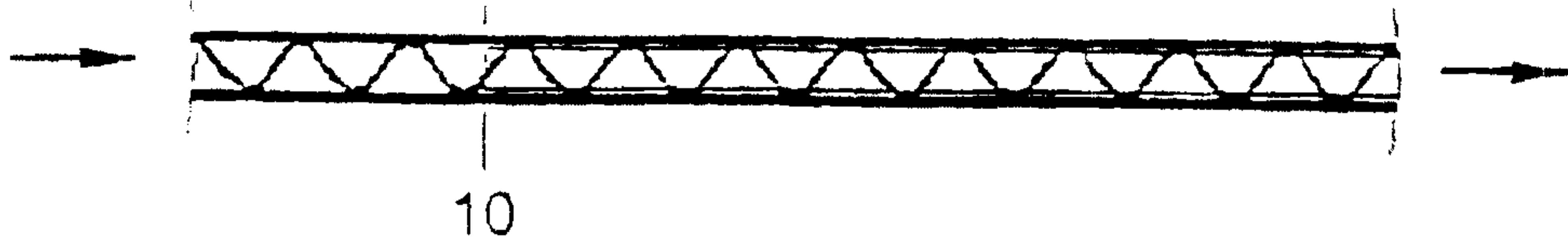

Fig. 1



b Welle FLUTE

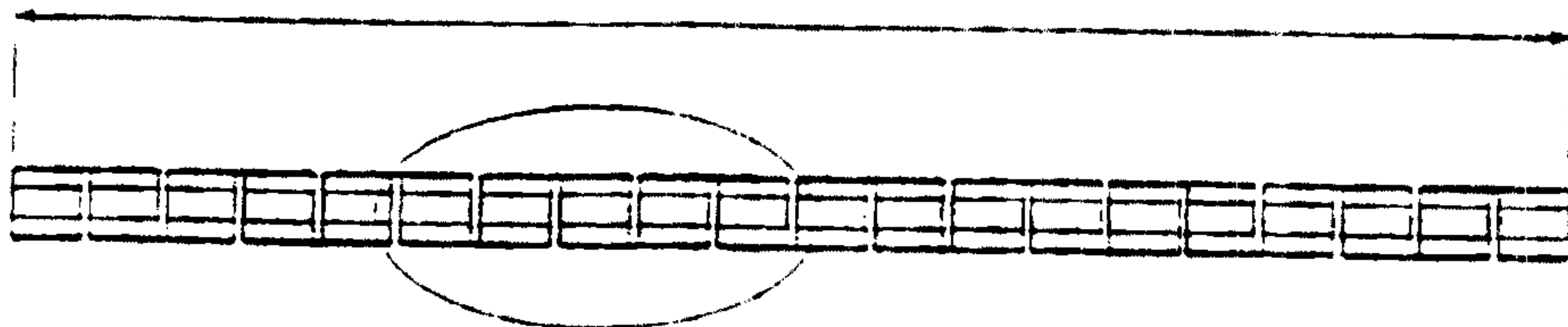
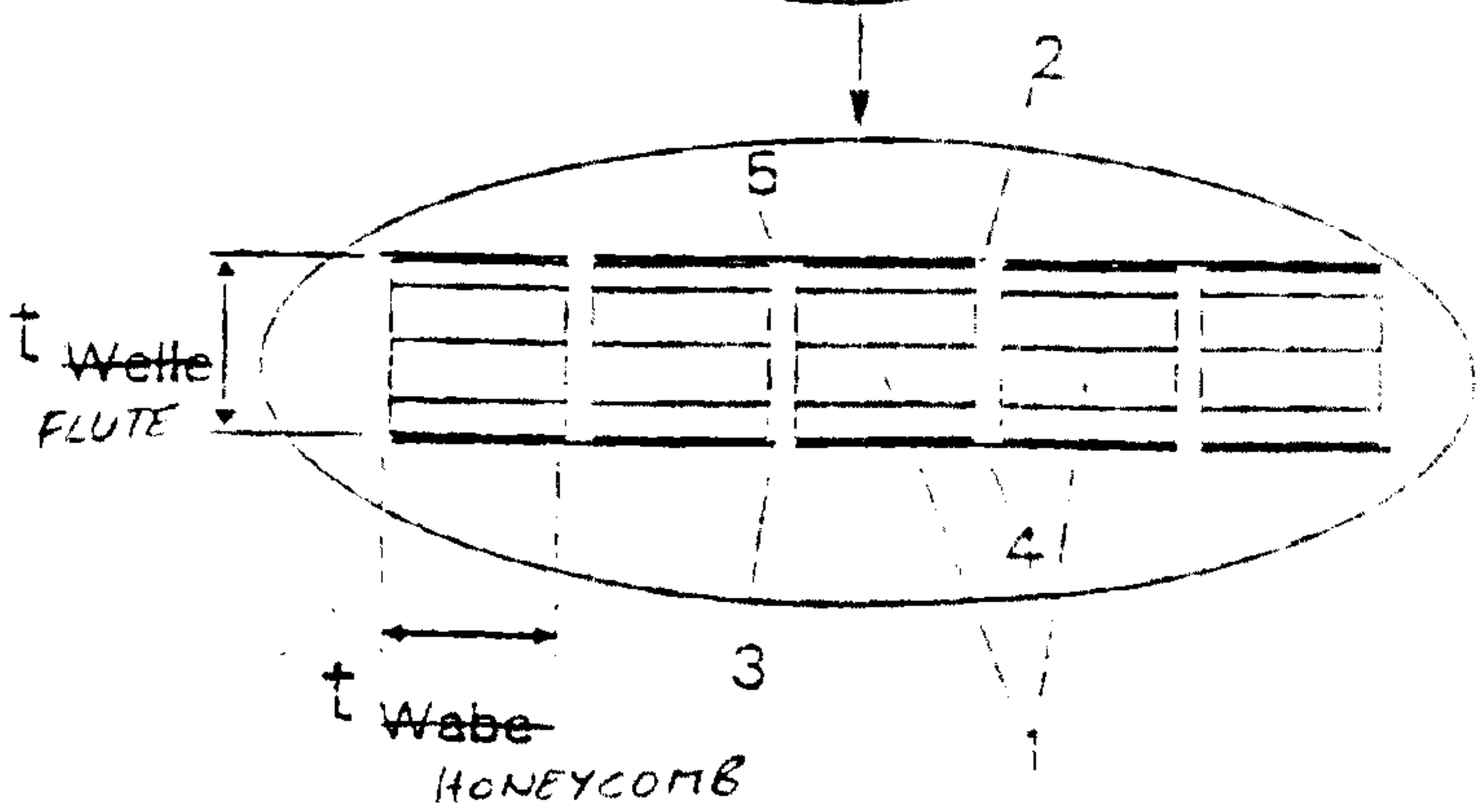

Fig. 2



ERSATZBLATT (REGEL 26)

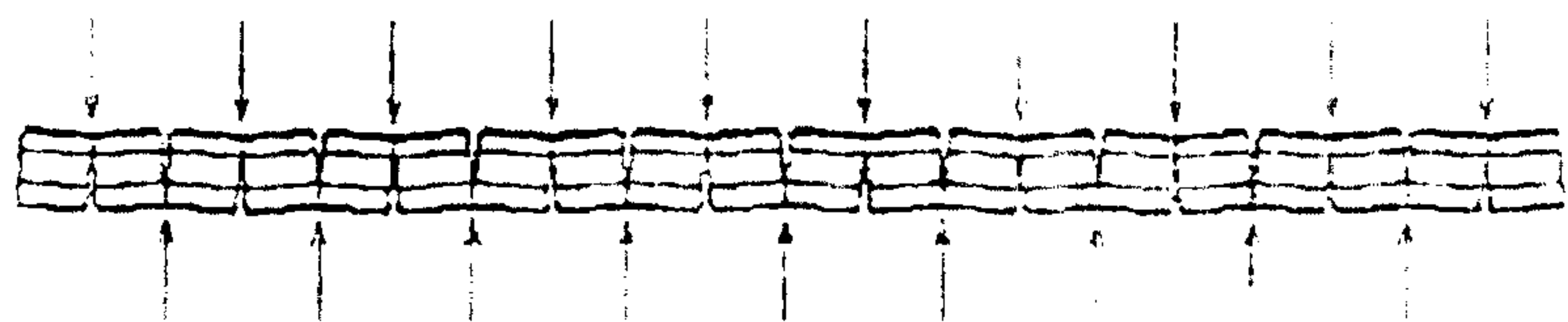

Fig. 3

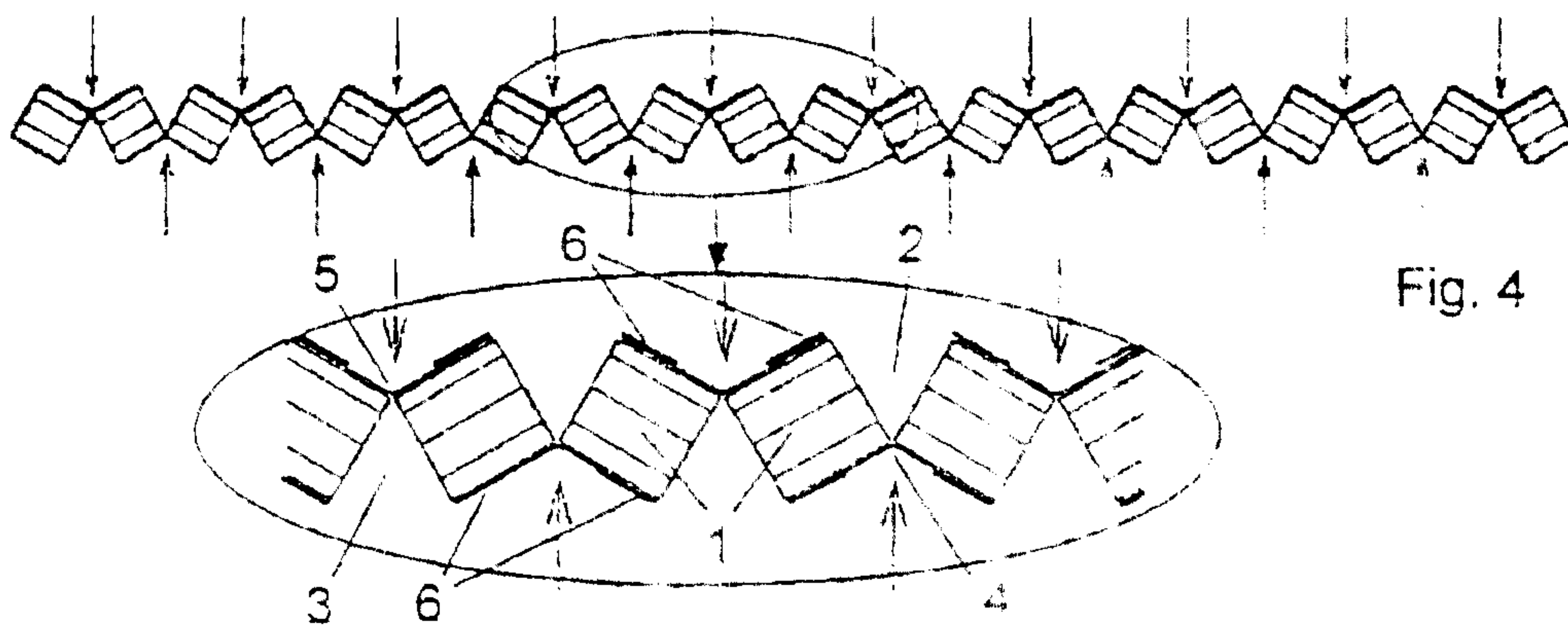

Fig. 4

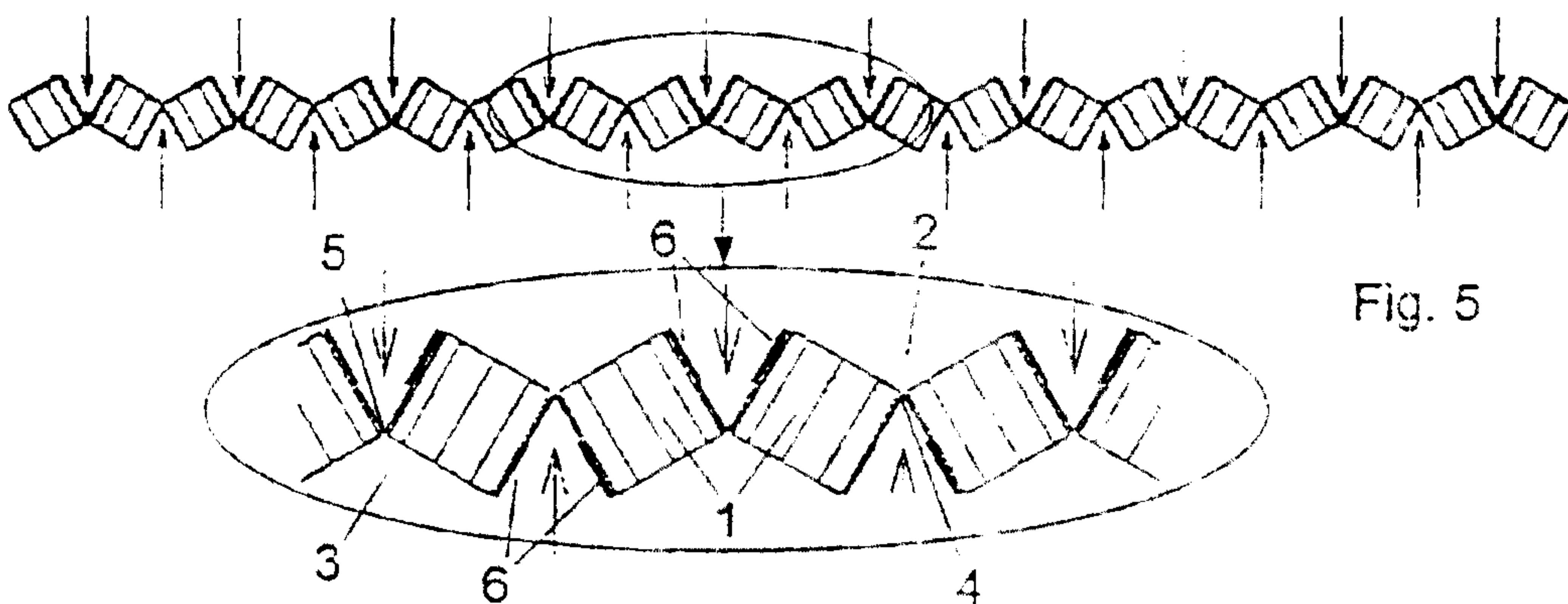

Fig. 5

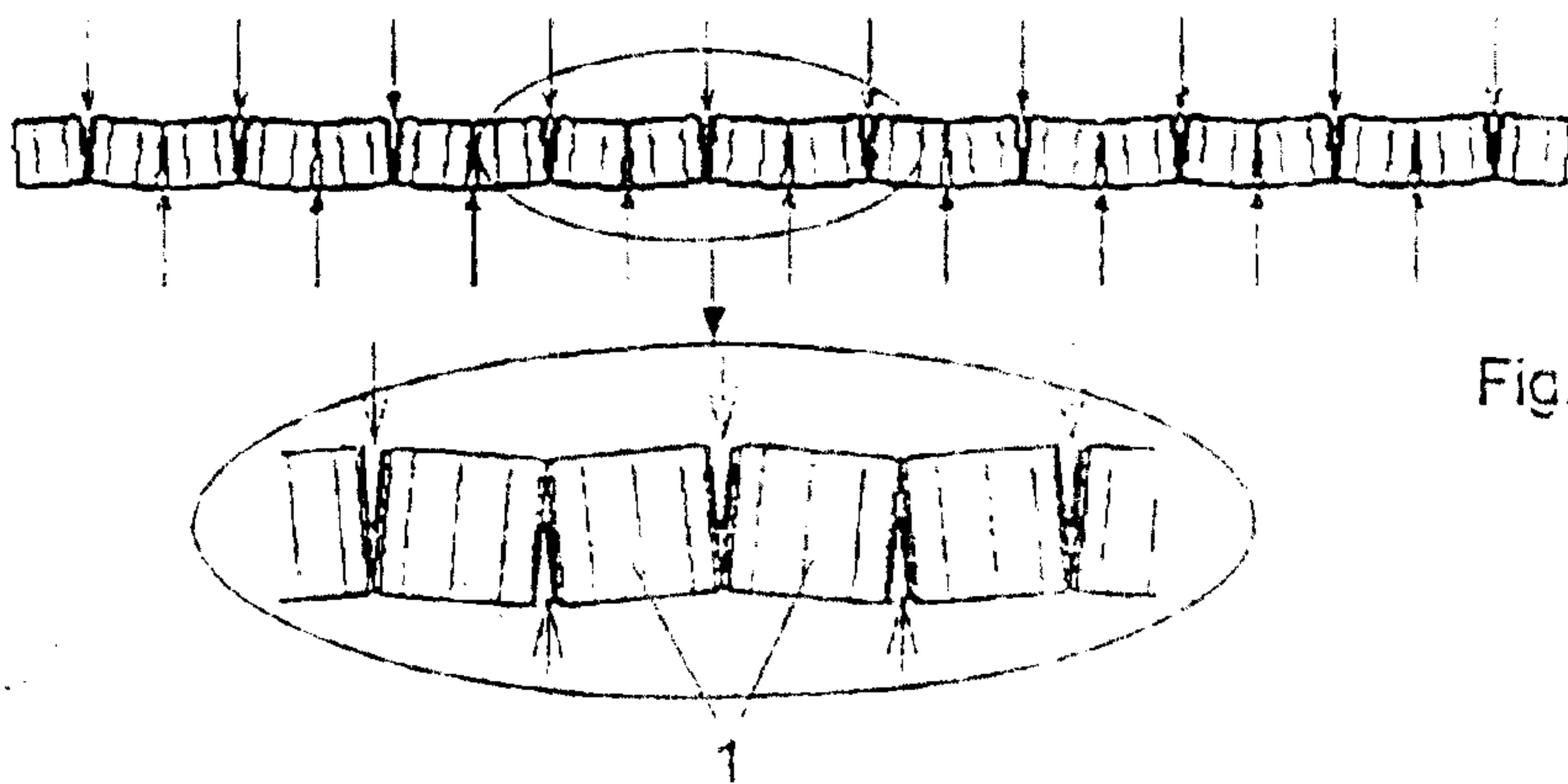

Fig. 6

WO 00/58080

3/7

PCT/EP00/02646

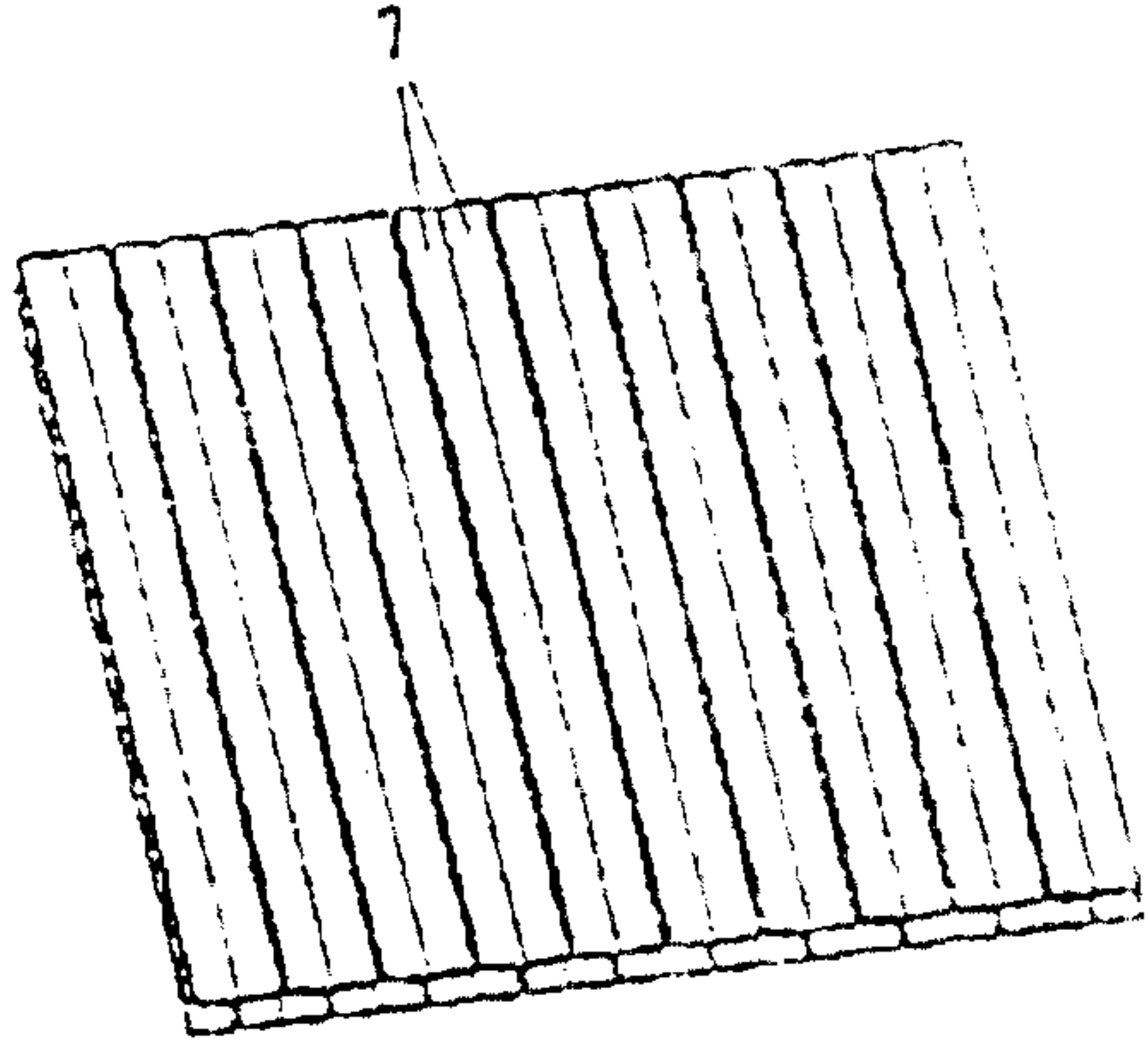

Fig. 7

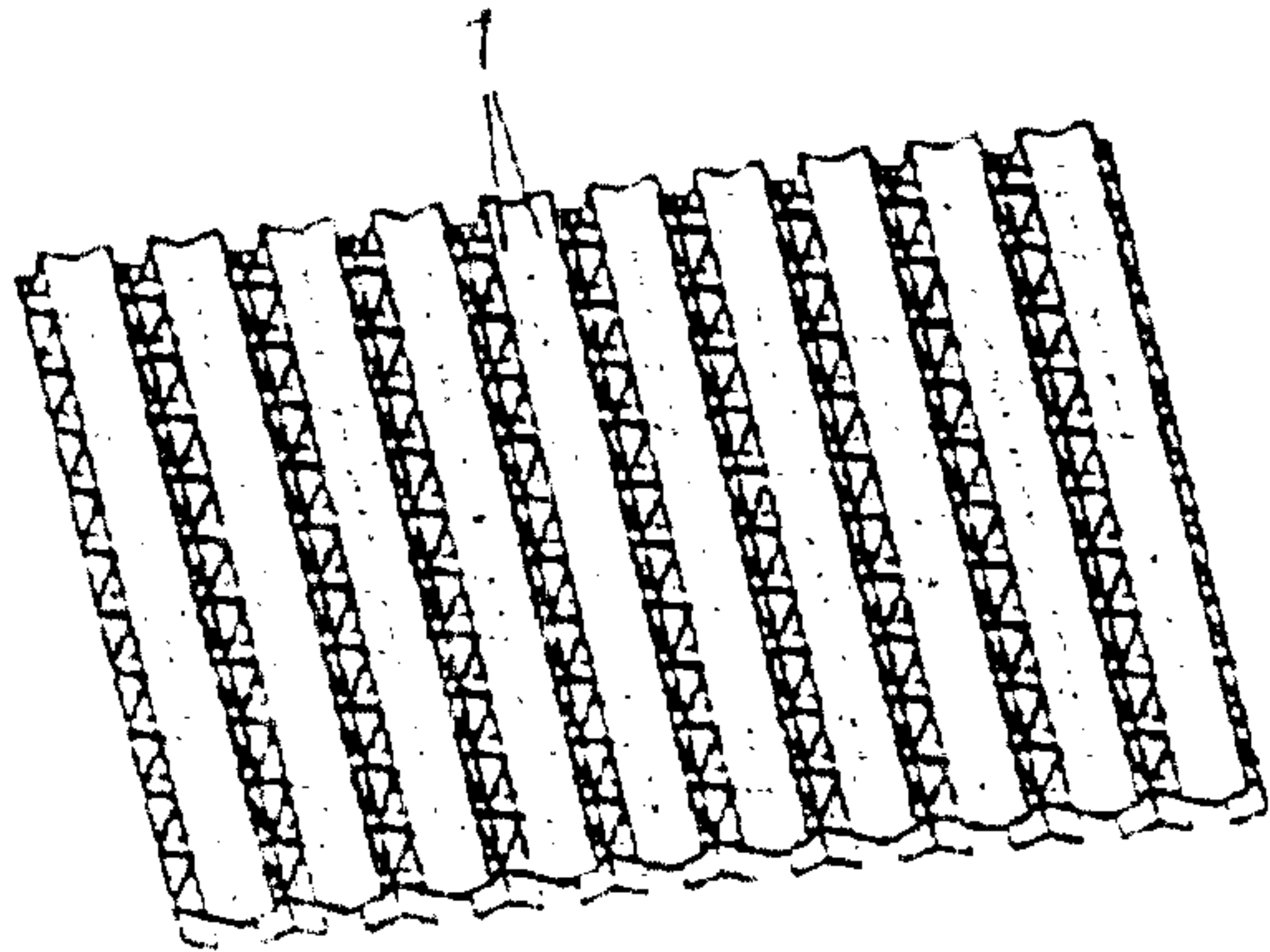

Fig. 8

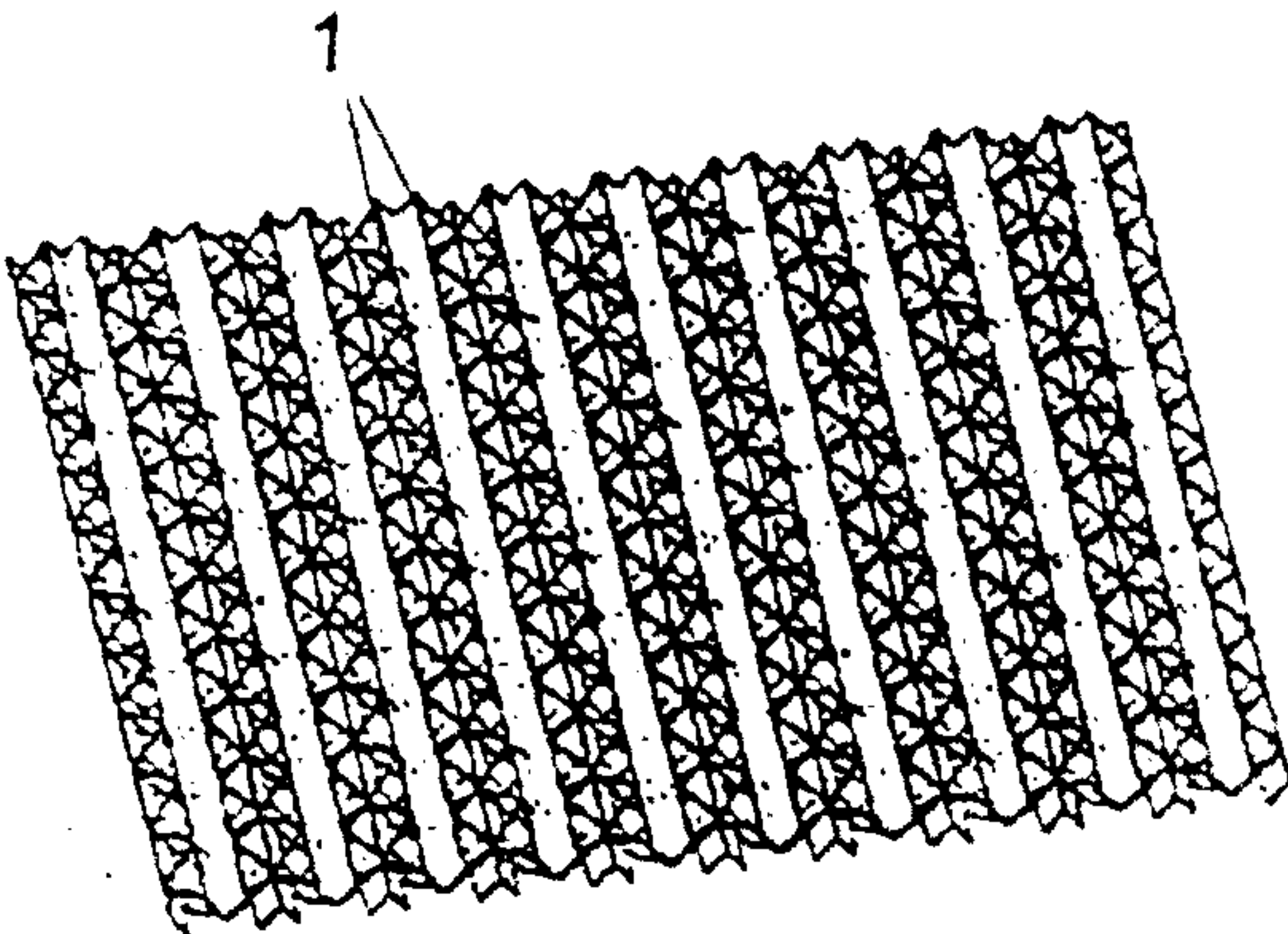

Fig. 9

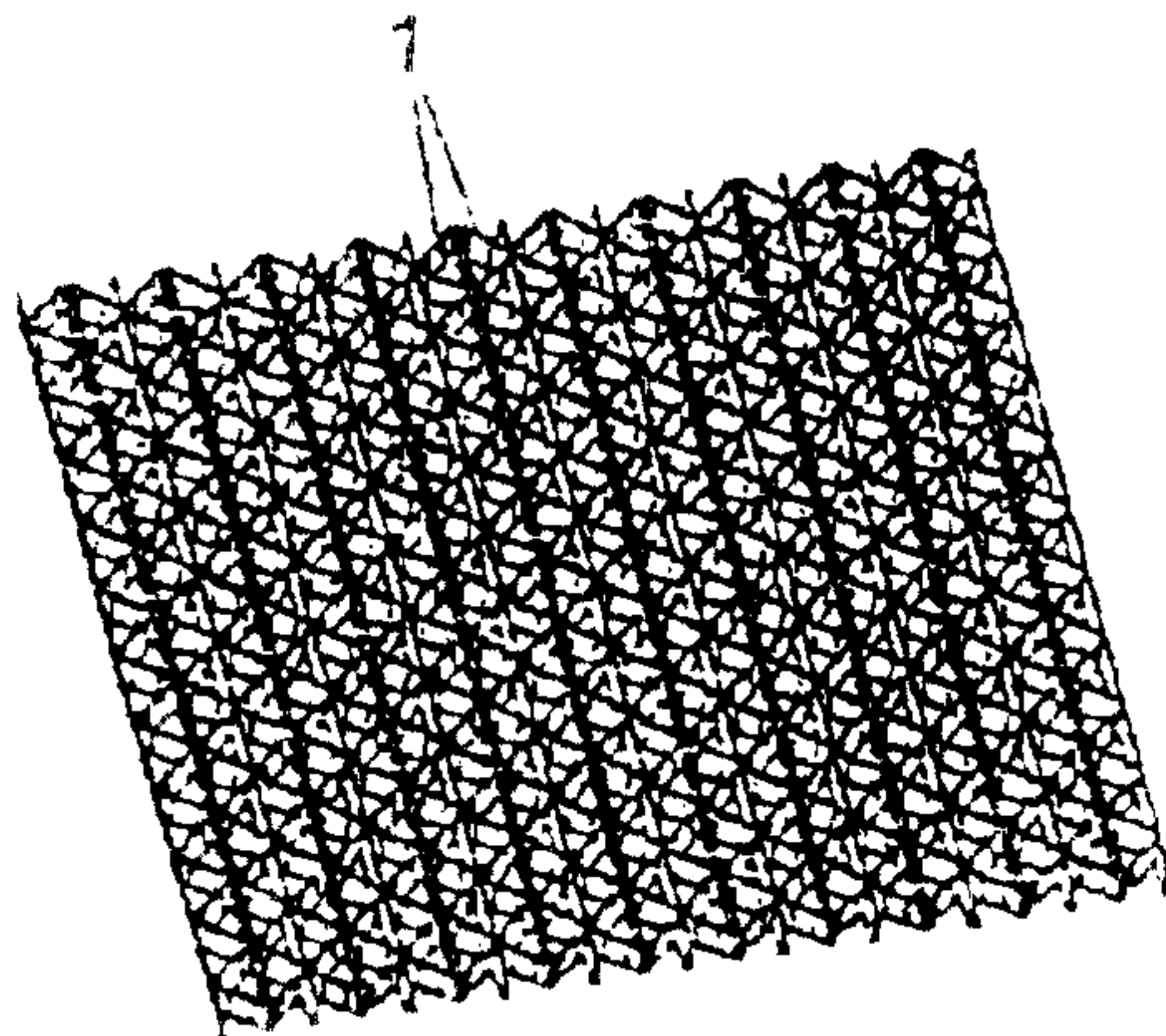

Fig. 10



Fig. 11

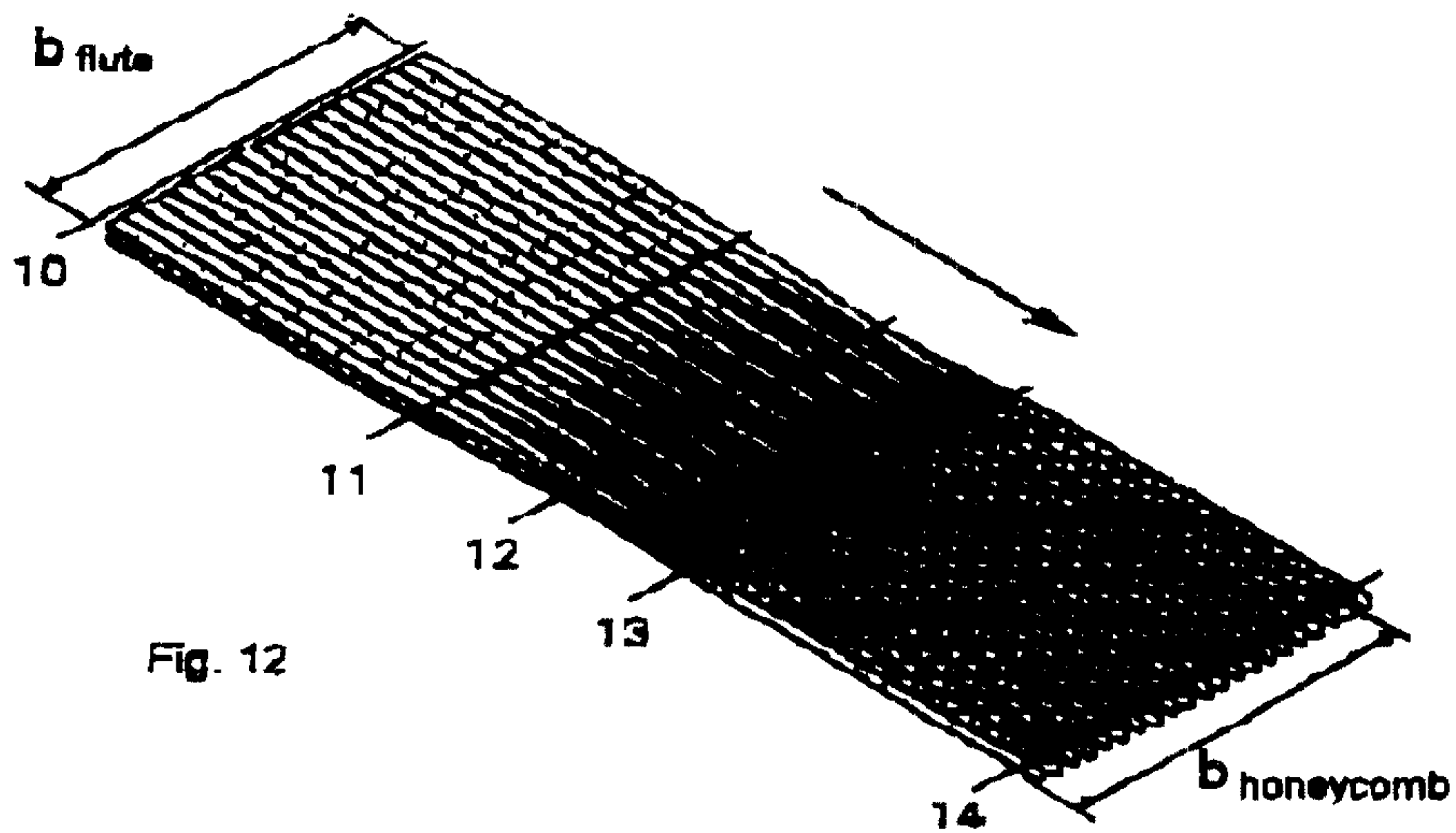

Fig. 12

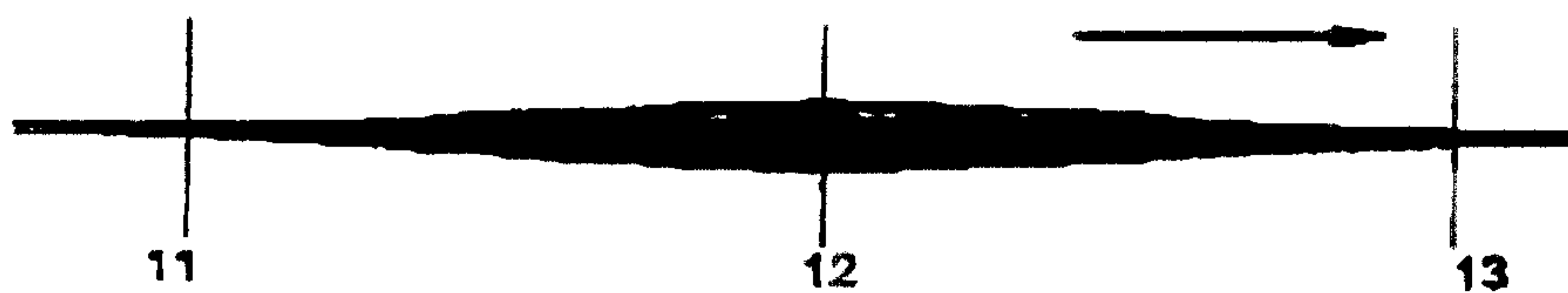

Fig. 13



Fig. 14

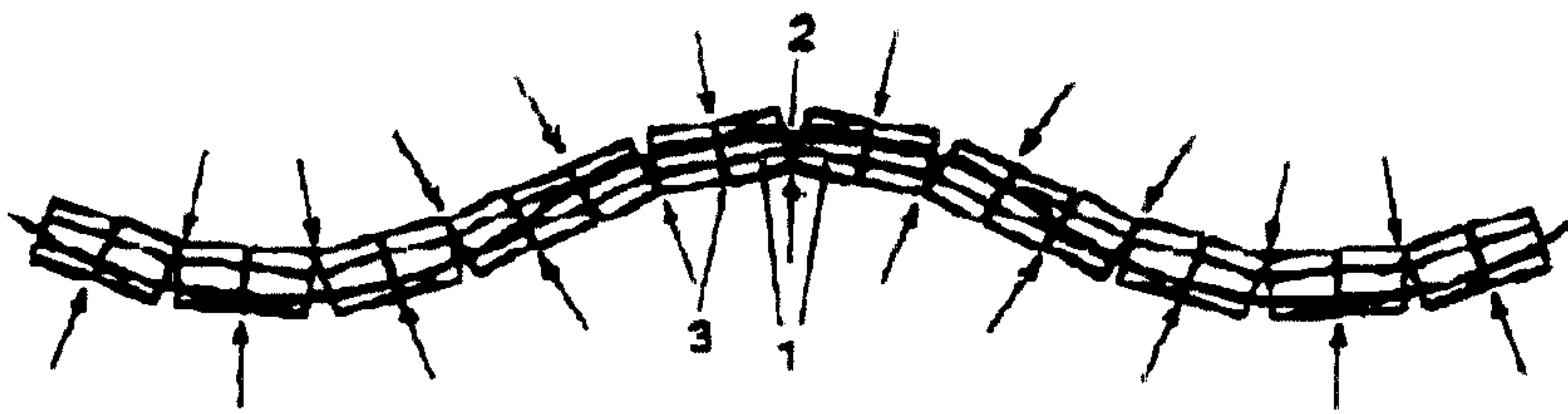

Fig. 15

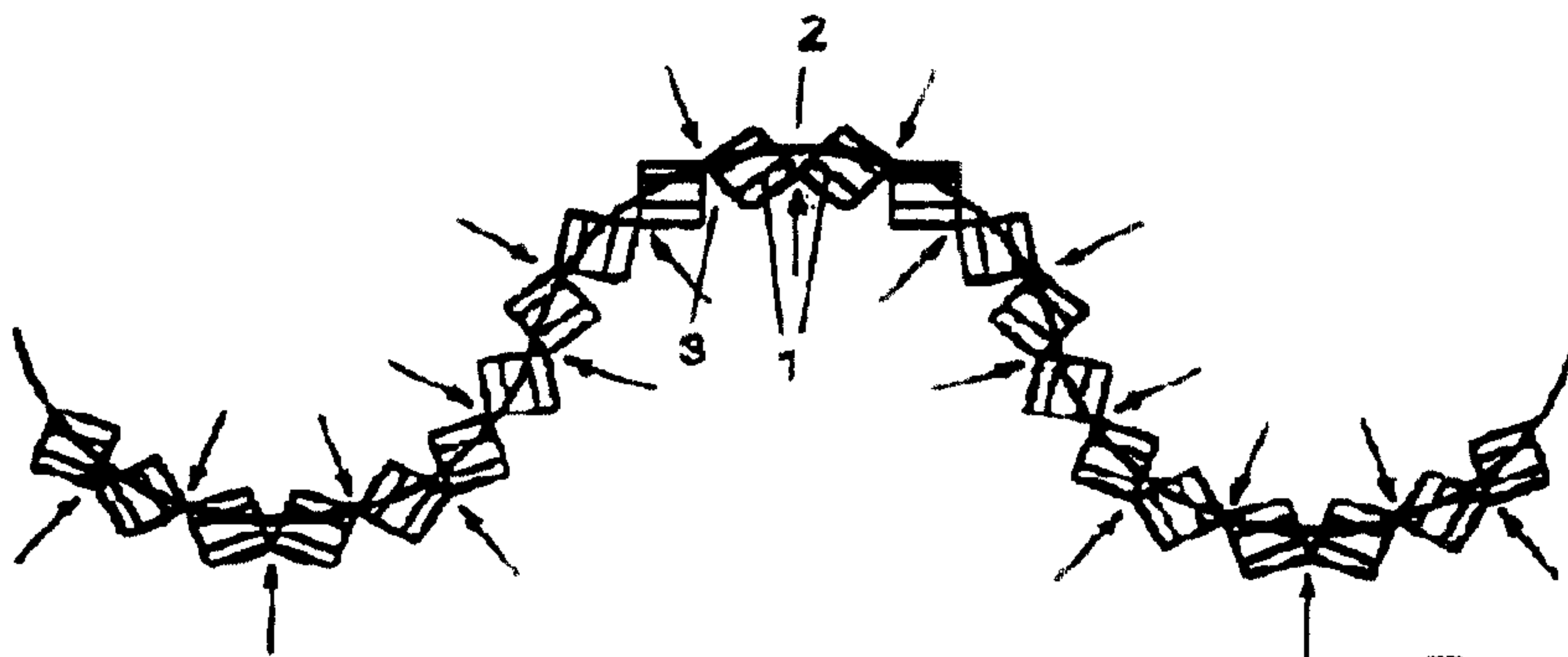

Fig. 16

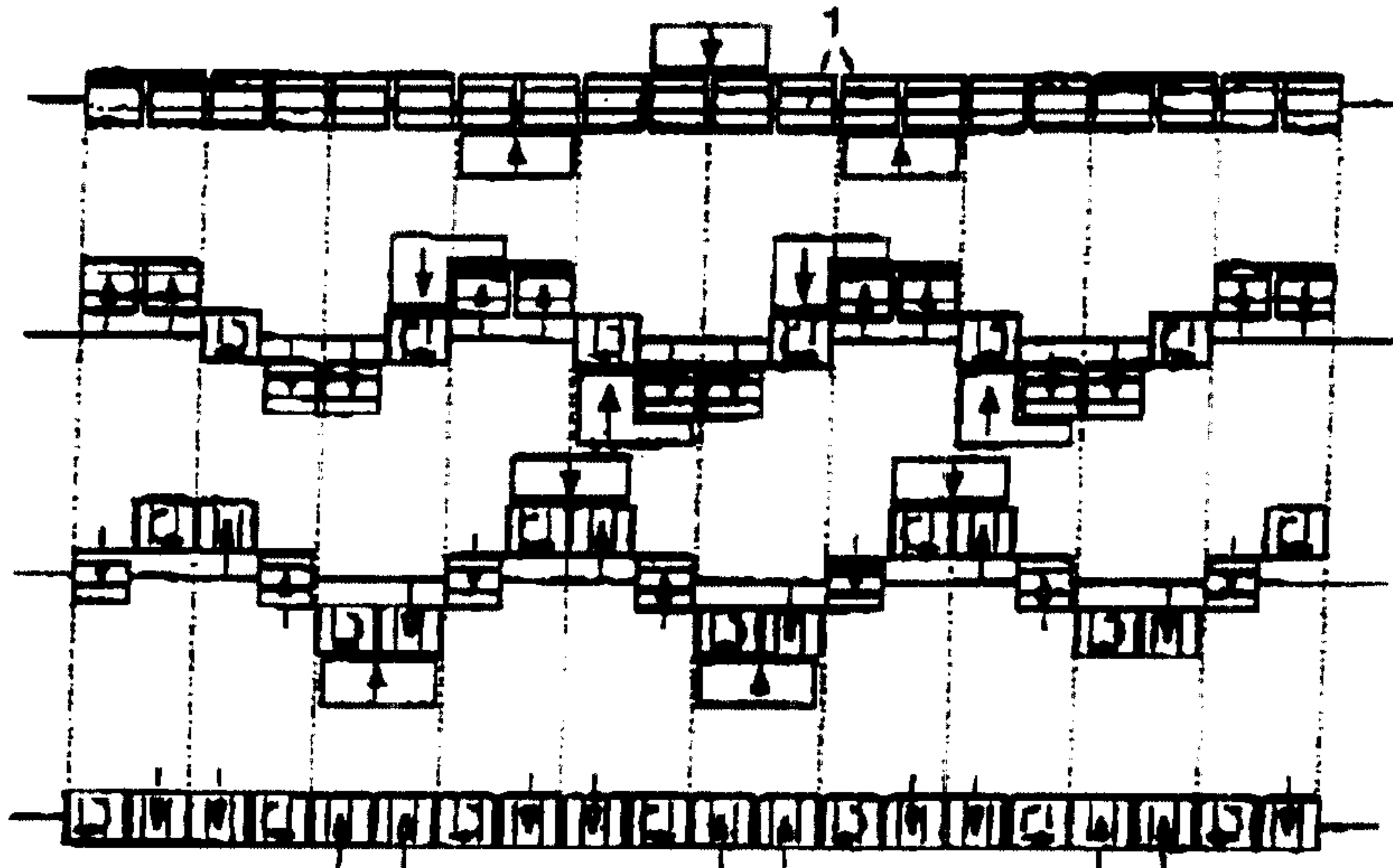

Fig. 17

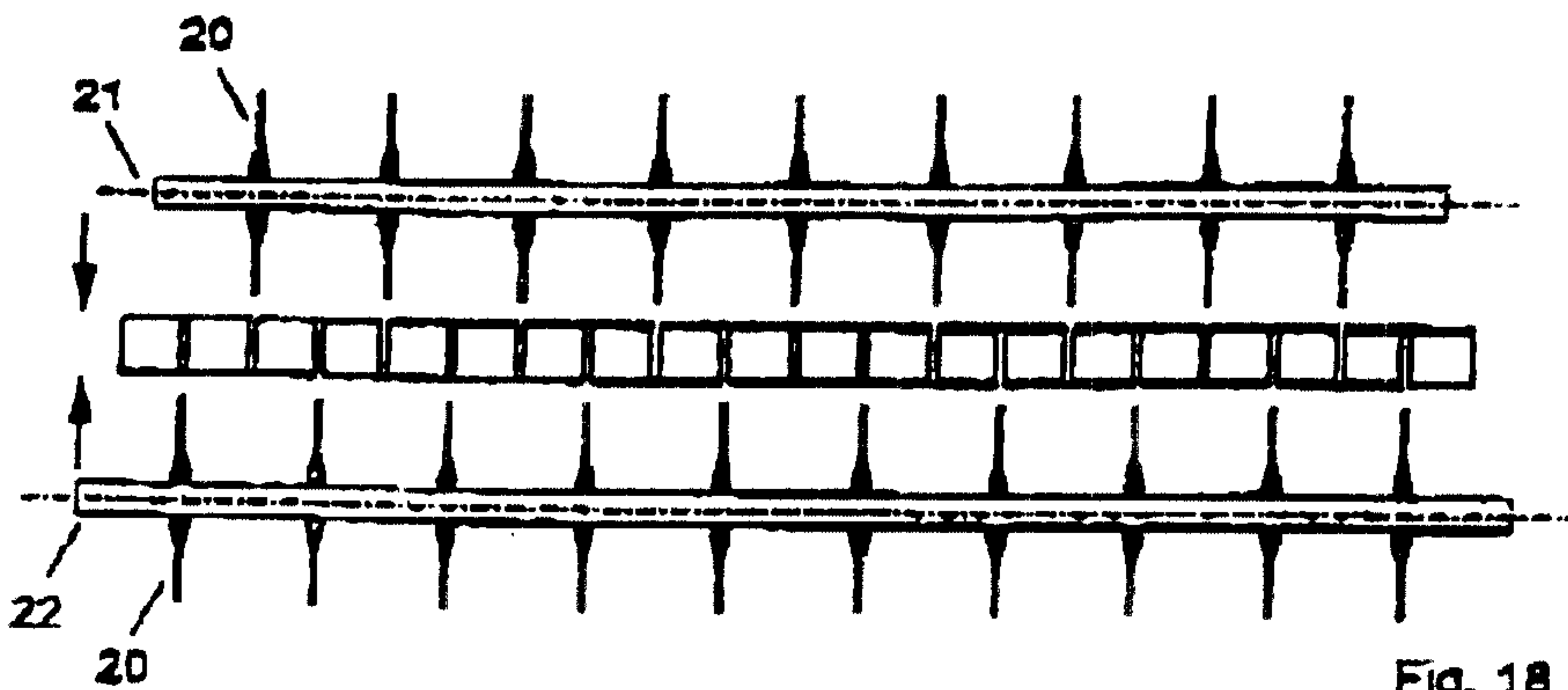

Fig. 18

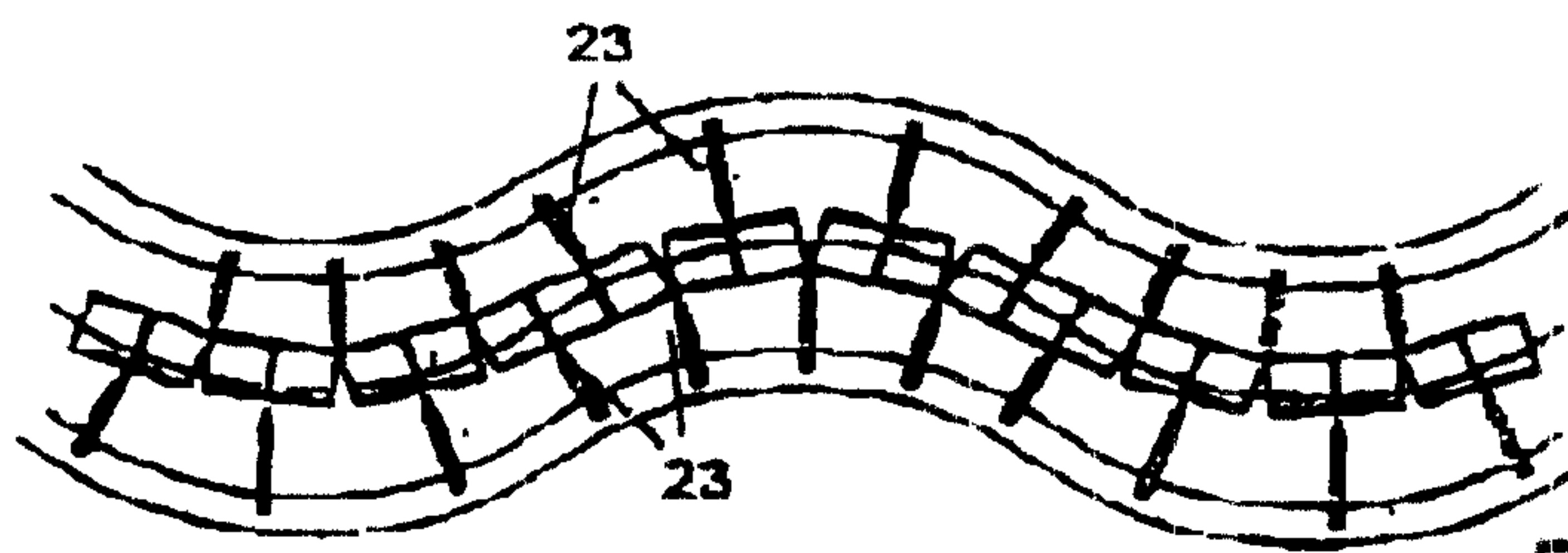

Fig. 20

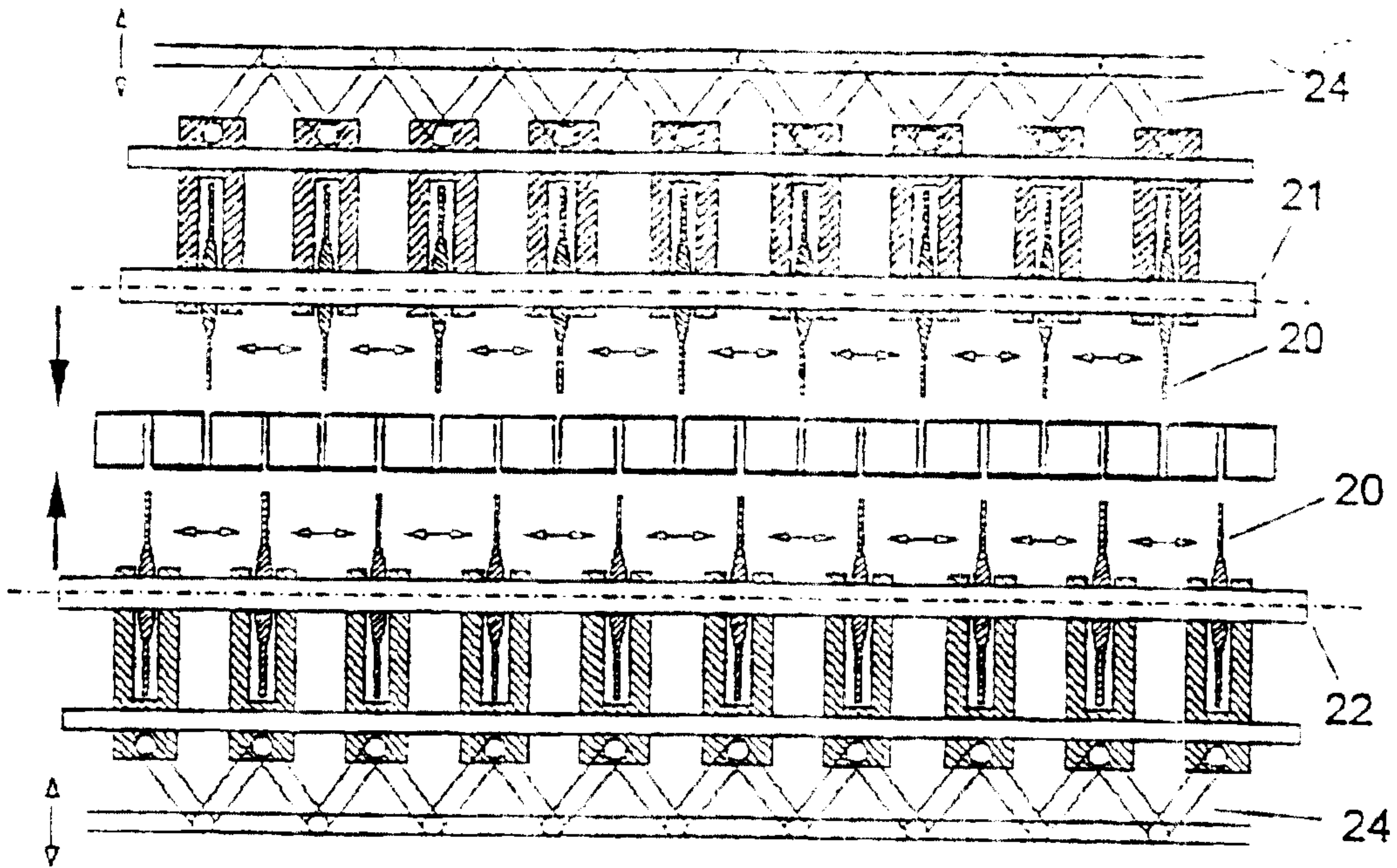

Fig. 19

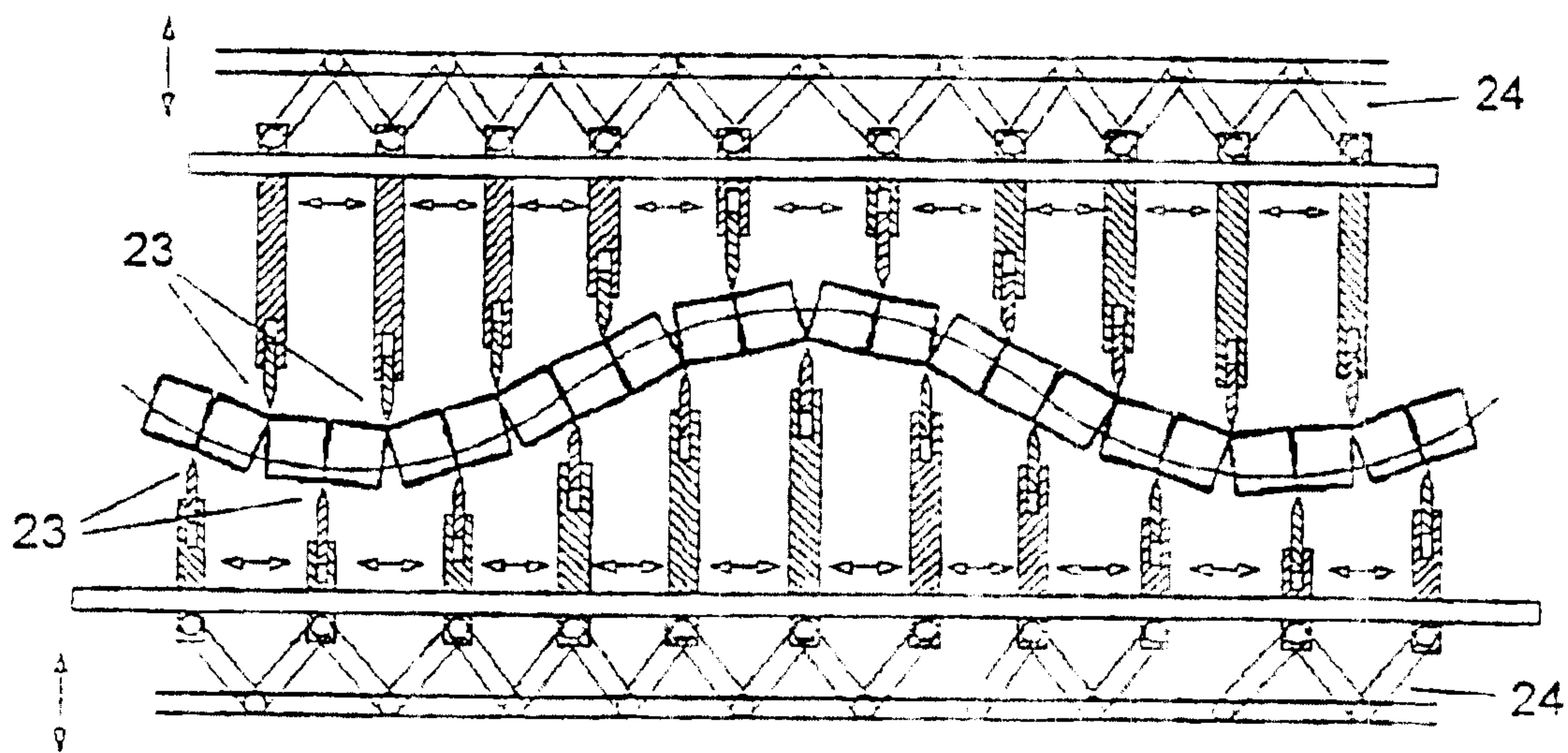

Fig. 21

Application number/ Numéro de demande : EP002646

Documents of poor quality scanned

(request original documents in File Prep. Section on the 10th floor)

Documents de piètre qualité numérisés

(Pour obtenir les documents originaux, veuillez vous adresser à la Section de préparation des dossiers, située au 10^e étage)

