



(86) Date de dépôt PCT/PCT Filing Date: 2003/06/06  
 (87) Date publication PCT/PCT Publication Date: 2003/12/24  
 (45) Date de délivrance/Issue Date: 2011/12/06  
 (85) Entrée phase nationale/National Entry: 2004/11/25  
 (86) N° demande PCT/PCT Application No.: US 2003/017809  
 (87) N° publication PCT/PCT Publication No.: 2003/106094  
 (30) Priorités/Priorities: 2002/06/12 (US60/388,200);  
 2003/06/05 (US10/455,292)

(51) Cl.Int./Int.Cl. *B22F 9/14* (2006.01),  
*B05D 3/08* (2006.01), *B23K 10/00* (2006.01),  
*B23K 9/00* (2006.01), *B23K 9/02* (2006.01),  
*C01B 31/18* (2006.01), *C01B 31/36* (2006.01),  
*C01B 33/20* (2006.01), *C22C 1/00* (2006.01),  
*C22C 29/00* (2006.01), *C22C 29/12* (2006.01),  
*C23C 4/10* (2006.01), *H05H 1/24* (2006.01)

(72) Inventeurs/Inventors:  
 SCHRODER, KURT A., US;  
 JACKSON, DOUG K., US

(73) Propriétaire/Owner:  
 NCC NANO, LLC, US

(74) Agent: KIRBY EADES GALE BAKER

(54) Titre : CANON A DECHARGE EN ARC PULSE RADIAL DESTINE A LA SYNTHESE DE NANOPOUDRE  
 (54) Title: RADIAL PULSED ARC DISCHARGE GUN FOR SYNTHESIZING NANOPOWDERS

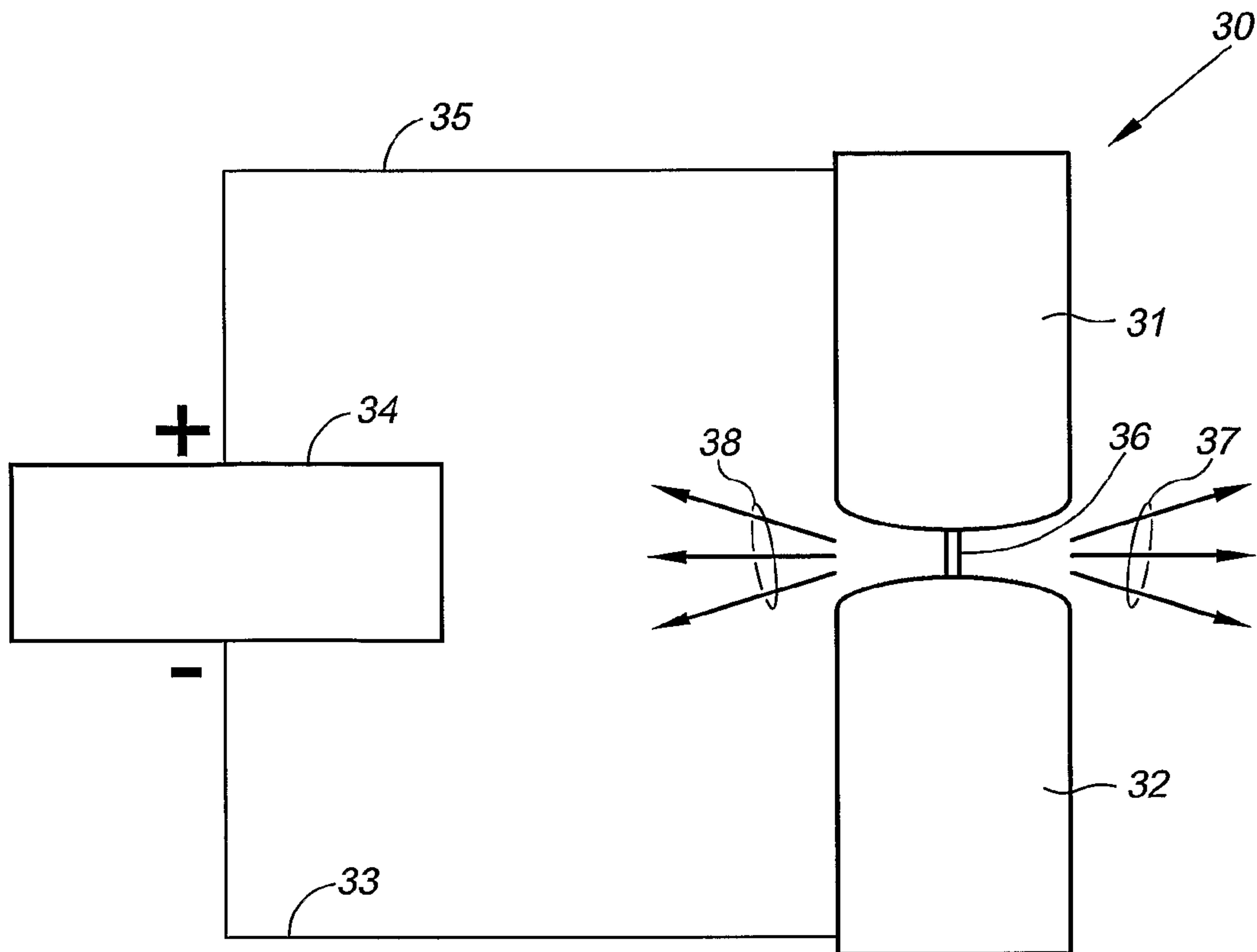

(57) Abrégé/Abstract:

A system and method for synthesizing nanopowder which provides for precursor material ablation from two opposing electrodes that are substantially axially aligned and spaced apart within a gaseous atmosphere, where a plasma is created by a high power pulsed electrical discharge between the electrodes, such pulse being of short duration to inertially confine the plasma, thereby creating a high temperature and high density plasma having high quench and/or reaction rates with the gaseous atmosphere for improved nanopowder synthesis.

**ABSTRACT**

A system and method for synthesizing nanopowder which provides for precursor material ablation from two opposing electrodes that are substantially axially aligned and spaced apart within a gaseous atmosphere, where a plasma is created by a high power  
5 pulsed electrical discharge between the electrodes, such pulse being of short duration to inertially confine the plasma, thereby creating a high temperature and high density plasma having high quench and/or reaction rates with the gaseous atmosphere for improved nanopowder synthesis.

**RADIAL PULSED ARC DISCHARGE GUN FOR SYNTHESIZING NANOPOWDERS**

5

10

**BACKGROUND OF THE INVENTION**

Systems for producing nanopowders are known which ionize an inert gas to create a  
15 plasma in a reactor vessel that vaporizes a precursor material. A quench and/or reaction gas  
is injected into the vaporized precursor material to produce nanopowders having a desired  
composition. U.S. Patent No. 5,514,349 discloses a transferred arc system similar to a  
tungsten inert gas (TIG) welder, wherein a single rod of metal precursor material acts as an  
anode, and is vaporized by feeding the anode past a nonconsumable tungsten cathode to  
20 expose the anode to a discharge arc. A gas is then injected into the vaporized material to  
quench and form the nanopowder. The transferred arc system is designed to avoid erosion of  
the tungsten electrode.

U.S. Patent No. 6,472,632 discloses another method to produce nanopowders which  
25 uses a prior art axial electrothermal gun, as illustrated in Figure 1. The axial electrothermal  
gun or axial gun 10 is shown with a breech electrode 11, an annular muzzle electrode 12, and  
a barrel 13 having a hollow bore 14. The breech electrode 11 fits into and pneumatically  
seals one end of the hollow bore 14. The muzzle electrode 12 is attached to and substantially  
axially aligned with the barrel 13. The breech electrode 11 further is connected by way of a  
30 conducting wire 15 to the negative terminal of a high-power, pulsed discharge power supply  
16, the positive terminal of which is connected by way of a conducting wire 17 to the muzzle  
electrode 12. Unlike the transferred arc system, the polarity of the electrodes in the axial gun  
10 is not important, and the device can be operated with the polarity reversed. This axial gun



embodiment has been successful in producing moderate volumes of nanopowder in the 10-100 nanometer range.

In operation, the power supply 16 is energized to create an electric field between the breech electrode 11 and the muzzle electrode 12, and thereby discharge a high power pulsed arc 18 between the electrodes. The discharge of the pulsed arc 18 ablates the muzzle electrode 12, which is the primary source for plasma. More particularly, the material removal rate from the muzzle electrode 12 is a factor of 10-100 greater than the material removal rate from the breech electrode 11.

The pulsed arc discharge in the axial gun 10 occurs in an interval of time too short to allow the plasma to fully expand and equilibrate in the surrounding atmosphere (inertial confinement), and in an area physically confined by the walls of the bore 14 (physical confinement). The combined confinement creates a high temperature ( $\sim 50,000^\circ\text{K}$ ), high density ( $\sim 10^{20}/\text{cm}^3$ ) plasma which is not ordinarily obtainable in other plasma based systems such as those disclosed by U.S. Patent Nos. 5,514,349; 5,874,684; and 5,851,507. The plasma acts to ablate the muzzle electrode 12 by means of the rapidly exiting high-temperature plasma. The plasma together with the ablated material exits the muzzle 12 under high pressure ( $\sim 15,000\text{PSI}$ ) and supersonic velocity. The ablated material thereafter may be quenched by and/or reacted with a surrounding gas such as one or more of air, oxygen, nitrogen, or helium to produce a cloud of nanopowder.

Referring to Figure 2, a prior art transferred-arc-discharge process is illustrated in which a tungsten electrode 20 is shielded in a flow of pure inert gas 21 such as Argon, and is principally aligned with a rod 22 of precursor material. The inert gas shield protects the tungsten electrode 20 from erosion and oxidation. The inert gas ionizes to sustain the arc, but does not act to quench or react with material removed from rod 22.

Rod 22 is connected by way of a conducting wire 23 to the positive terminal of a DC power supply 24, the negative terminal of which is connected by way of a conducting wire 25 to the tungsten electrode 20. The tungsten electrode 20 is charged negatively with respect to the rod 22 to retard the absorption of heat and rate of erosion of the tungsten electrode. With

these polarities, the material removal rate from the rod 22 is a factor of 100-1000 times greater than that of the tungsten electrode 20.

In operation, the DC power supply 24 is energized to effect a continuous DC low power arc discharge between the tungsten electrode 20 and the rod 22. The arc discharge erodes rather than ablates the rod 22. The material so produced is conveyed away from the vicinity of the arc discharge by the flow of the pure inert gas 21, and injected with a quench and/or reaction gas(es) 21, such as argon, helium and oxygen, to form the nanopowder.

From the above, it should be readily apparent that material removal in the operation of a transferred arc process, or an axial gun process is primarily from a single electrode.

#### BRIEF DESCRIPTION OF THE DRAWINGS

While the novel aspects and features of the invention are defined in the appended claims, the principles of the invention, illustrative embodiments, and preferred modes of use are best understood by reference to the Description Of Preferred Embodiments in conjunction with the following drawings, in which:

Figure 1 is a graphic diagram of an axial electrothermal gun in the prior art, which is comprised of a breech electrode, a muzzle electrode, and a hollow bore;

Figure 2 is a graphic diagram of a transferred-arc-discharge process in the prior art, which is comprised of a tungsten electrode that is charged negative with respect to an anode electrode composed of precursor material;

Figure 3 is a graphic diagram of a radial electrothermal gun in accordance with the present invention, wherein an anode and a cathode of the gun are each composed of a precursor material, and are substantially axially aligned but spaced apart opposite to each other; and





composition is typically the metal of the nanopowder being produced, such as but not limited to aluminum, tantalum, titanium, or zirconium. The nanopowder itself may be, but is not limited to, a metal such as aluminum or copper; an oxide such as  $Al_2O_3$  or  $TiO_2$ ; a nitride such  $TiN$ ,  $ZrN$ , or  $Ta_2N$ ; or other metals and metal compounds. Please refer to the article,  
5 “Pulsed Wire Discharge for Nanosize Powder Synthesis”, by Weihua Jiang and Kiyoshi Yatsui, IEEE Transactions On Plasma Science, vol. 26, No. 5, pp. 1498-1501 (October 1998).

The cathode electrode 32 is connected by way of a conducting wire 33 to the negative terminal of a pulsed power supply 34, the positive terminal of which is connected by way of a  
10 conducting wire 35 to the anode electrode 31. The pulsed power supply 34 may be of any of plural well known designs (which may vary depending upon the material and material size being produced) that are offered by and ordered from any of numerous well known manufacturers. Except for the pulsed power supply 34, the radial gun 30 may but need not be contained within a chamber or reactor vessel such as that disclosed in U.S. Patent No. 5,  
15 514,349. The reactor vessel is filled with inert and/or reactive gases including but not limited to Argon, Nitrogen, Oxygen, or a combination thereof. The selection of the gaseous atmosphere is based upon the nanopowder that is desired, and the effect of the gas is to control the expansion and quench rate of the plasma that is created by a high-power pulsed electrical discharge between the anode electrode 31 and the cathode electrode 32.

20

In operation, the pulsed power supply 34 is energized to effect a high-power pulsed electrical discharge 36 between the cathode electrode 32 and anode electrode 31. For the current invention, the connection to the electrodes could easily be reversed in polarity without impacting the process. The energy from the discharge melts, vaporizes and ionizes material  
25 from the two electrodes to create a high temperature (of the order of 50,000 °K), high density metal plasma which continues to sustain the electrical discharge from the pulsed power supply. The combined physical axial confinement provided by the electrodes and the inertial confinement resulting from the short term pulse of the electrical discharge, act to increase the temperature and density of the plasma to heights not ordinarily obtainable by other  
30 nanopowder synthesizing processes or apparatus. Since the electrodes impede axial expansion of the plasma, expansion occurs primarily radially as indicated by arrows 37 and 38 of Figure 3. As the plasma expands, additional material is ablated from the electrodes. This additional material also contributes to the overall plasma and helps sustain the electrical



discharge between the electrodes. The expanding plasma is forced out of the confines of the radial gun at supersonic speeds. It subsequently undergoes expansion, mixes with the chamber gases, and quenches at a rate of the order of  $10^6$  °K/sec to form nanopowder. Depending on the ambient gas, the plasma may also react with the gaseous atmosphere to form compounds as it is being quenched.

After each high power electrical discharge, the pulsed power supply 34 is reenergized. Further, after nanopowder is produced from one or more high power, pulsed electrical discharges between the electrodes, the anode electrode 31 and the cathode electrode 32 are indexed toward each other only as required to maintain the production rate. The gas surrounding the electrodes is replenished as necessary to sustain the atmosphere within the reactor vessel.

It is to be understood that the above process may occur without the benefit of a reactor vessel or chamber, as the plasma created by the present invention need only be quenched by or reacted with a surrounding gaseous atmosphere to produce a desired nanopowder.

TABLE I

20

SYNTHESIZING DEVICE	ELECTRODE	PRIMARY MATERIAL REMOVAL MECHANISM	RELATIVE AMOUNTS OF MATERIAL REMOVED
Transferred Arc	Tungsten	Arc Erosion (Minimized)	1
	FeedStock	Arc Erosion	100-1000
Axial Gun	Breech	Arc Erosion	1
	Muzzle	Ablation	10-100
Radial Gun	Electrode 1	Ablation	~ 1
	Electrode 2	Ablation	~ 1



In Table I above, relative removal rates between electrodes of a same nanopowder synthesis device are shown. Table I is not intended to show comparisons between synthesis devices.

5 Referring to Table I, it is seen that the two electrodes of the radial gun each serve almost equally as sources of ablative material. By way of contradistinction, both the axial gun and the transferred arc synthesizing devices have only one electrode that contributes to any substantial degree to the production of nanopowder.

10 Readily apparent differences between the transferred-arc processes and the radial gun are: (1) polarity reversal is of little to no effect in the radial gun, because the electrode material removal caused by erosion is negligible compared to the material removal from ablation; (2) material removal with a radial gun occurs at two electrodes rather than a single electrode; (3) no inert gas shielding is required by the radial gun to protect against electrode  
15 erosion; and (4) the power supply of the radial gun is pulsed rather than continuous.

The radial electrothermal gun also provides the following additional advantages over the transferred-arc processes for synthesizing nanopowder:

20 i. Increased quench rate of  $10^6 - 10^8$  degrees Kelvin/sec. with the radial electrothermal gun (as compared to  $10^4$  degrees Kelvin/sec. with the forced convection quenching used with the transferred arc processes) allows smaller sized nanopowder to be synthesized in higher aerosol densities;

25 ii. More uniform time-temperature nanoparticle synthesis, i.e. nucleation and growth, histories are provided with a radial gun which result in more uniform nanoparticle sizes;

iii. The increased plasma temperature occurring in a radial gun allows the synthesis of nanopowder from material having very high melting and boiling points;

30

iv. Less energy is used to produce greater quantities of nanopowder because the short duration of the pulsed discharge does not allow sufficient time for thermal diffusion.

Consequently, there are fewer thermal (energy) losses to the surrounding environment; and

v. Lower agglomeration of nanopowder occurs with the radial gun.

vi. Since both the cathode and the anode of the radial gun are made out of the precursor or ablative material, no contamination is introduced from the electrodes. Inherent to the transferred arc process is the contamination that comes from the tungsten electrode.

The radial electrothermal gun provides advantages including the following over the axial electrothermal gun in synthesizing nanopowder:

10

i. No high pressure seals are needed since the only physical confinement comes from the electrodes;

ii. No insulating bore is required. Thus, a source of both major cost, and impurities in the production of nanopowder is removed;

15

iii. The electrodes can be large diameter rods requiring almost no machining, thus further reducing cost; and

20

iv. The electrodes are nearly all consumed.

A further comparison among the radial gun of the present invention, and prior art axial guns and transferred arc processes appears, in Table II below.

25

TABLE II

COMPARISON BETWEEN PRIOR ART AND RADIAL GUN

	RADIAL GUN	AXIAL GUN	TRANSFERRED ARC DISCHARGE
Peak Discharge Power	$10^8$	$10^8$	$10^5$

(Watts)			
Duty Cycle	Pulse	Pulse	Continuous
Pulse Length (sec.)	10 <sup>-3</sup>	10 <sup>-3</sup>	Infinite
Bore	None	Yes	None
Arc Confinement	Physical In Axial Direction, Inertial In Radial Direction	Physical In Radial Direction, Inertial In Axial Direction	None
Arc Temperature °K	50,000	50,000	10,000
Plasma Quench Mechanism	Supersonic Expansion Into Surrounding Atmosphere	Supersonic Expansion Into Surrounding Atmosphere	Externally Forced Convection
Plasma Expansion Between The Electrodes	Primarily Radial	Axial	N/A
Electrode Ablation	Both Electrodes	Primarily Muzzle Electrode, Lesser Extent Breech	None. Tungsten Electrode Erosion Is Minimized. Precursor Material is eroded.
Inert Gas Electrode Shielding	No	No	Yes
Effect Of Electrode Polarity Reversal	Little To No Effect	Little To No Effect	Non-Consumable Electrode Erosion And Nanopowder Contamination.

The radial gun embodiment of Figure 3 provides a substantial improvement in cost and efficiency. The high power (megawatt), electric discharge of the radial gun, however, may occur from time to time at other than the center of the electrodes. In this event, the resistance of the arc is decreased, and less energy may be added to the arc discharge for a



given arc current. The resulting plasma may be at a lower temperature and/or lower density than otherwise could be achieved, production rates are decreased, and the material produced is of a non-uniform quality. A solution to this problem is provided by the radial gun embodiment of Figure 4.

5

Referring to Figure 4, an alternative embodiment of the present invention is illustrated in which a first composite electrode 40 is comprised of a solid anode electrode 41 which is seated within a wider annular ablative body 42. The anode electrode 41 is electrically isolated from the annular ablative body 42 by an annular insulator body 43. Similarly, a second composite electrode 46 is comprised of a solid cathode electrode 47 which is seated within a wider annular ablative body 48. As before, the cathode electrode 47 is electrically isolated from the annular ablative body 48 by an annular insulator body 49.

10

The anode electrode 41 is connected electrically by way of a conducting wire 50 to the positive terminal of a high power, pulsed power supply 51, the negative terminal of which is electrically connected by way of a conducting wire 52 to the cathode electrode 47. The composite electrodes 40 and 46 are separated by an axial distance 53.

15

The anode electrode 41, cathode electrode 47, annular ablative body 42, and annular ablative body 48 may be of the same material. The annular ablative bodies 42 and 48 also may be of materials different from that of the anode electrode 41 and the cathode electrode 47, and even may be nonconductors since their purpose is to provide axial physical confinement of the plasma and to be ablated. In the event the annular ablative bodies 42 and 48 are nonconductors, no annular insulator is required between the ablative bodies and the electrodes.

20

25

As illustrated in Figure 4, the solid anode electrode 41 and the solid cathode electrode 47 have round uniform cross-sections. The electrodes may be composed of metals including, but not limited to, aluminum, copper, or iron. The annular ablative bodies 42 and 48 are hollow, and may be composed of the same materials as the electrodes, as well as nonconductive materials. The annular insulator bodies 43 and 49 respectively electrically isolate the anode electrode 41 and the cathode electrode 47 from the annular ablative bodies 42 and 48.

30

In operation, the pulsed power supply 51 is energized to cause a high-power, pulsed electrical discharge between the cathode electrode 47 and the anode electrode 41. The discharge arc will attach to the cathode and anode because they are conductors. As the cathode electrode 47 and anode electrode 41 are respectively located in the center of the composite electrodes 46 and 40, which are characterized by diameters that are larger than those of the cathode and anode, the discharge arc can be said to be physically confined to the center of the composite electrodes to a greater extent than provided by the anode and cathode electrodes of the same diameter in the radial gun embodiment of Figure 3. The construction of the composite electrodes 40 and 46 thus dramatically increase the probability of the discharge arc attaching to the tip areas of both the anode electrode 41 and the cathode electrode 47. The added confinement of the electrical discharge increases its energy to melt, vaporize and ionize material ablated from the anode electrode 41, the cathode electrode 47, and the two annular ablative bodies 42 and 48. Further, the composite electrodes 40 and 46 prevent the axial expansion of the plasma, and the inertial confinement afforded by the pulsed electrical discharge deters expansion of the plasma radially outward as indicated by arrows 54 and 55 of Figure 4. A high temperature, high density plasma thus is created. The ablation of the anode electrode 41, the cathode electrode 47, and the annular ablative bodies 42 and 48, by the high velocity exit of the plasma radially outward, produces nanopowder at an even higher rate per discharge than that of the invention embodiment illustrated in Figure 3 above. Further, the ablated material is forced out of the radial gun by the plasma at supersonic speed to be quickly quenched by and/or quickly react with the surrounding gas within the reactor vessel to produce nanopowder.

Although the preferred embodiments of the invention have been disclosed in detail, various substitutions, modifications, and alterations can be made without departing from the spirit and scope of the invention as defined in the Claims.



CLAIMS

1. An apparatus for synthesizing nanopowders, comprising:  
an anode electrode and a cathode electrode which are comprised of precursor material, and which are substantially axially aligned but spaced apart within a gaseous atmosphere; and  
5 a power supply which is in electrical communication with said anode electrode and said cathode electrode, and which effects a high power pulsed electrical discharge to ablate said anode electrode and said cathode electrode to produce nanopowders.
2. The apparatus of claim 1, wherein said gaseous atmosphere reacts with material  
10 ablated from said anode electrode and said cathode electrode to form said nanopowders.
3. The apparatus of claim 1, wherein said gaseous atmosphere quenches material ablated from said anode electrode and said cathode electrode to produce said nanopowders.
4. The apparatus of claim 1, wherein said anode electrode and said cathode electrode  
15 are of the same composition.
5. The apparatus of claim 1, wherein said gaseous atmosphere is a mixture of different gases, and said mixture both quenches and reacts with material ablated from said anode electrode and said cathode electrode.
6. The apparatus of claim 1, wherein said gaseous atmosphere is a mixture of  
20 different gases, and said mixture quenches material ablated from said anode electrode and said cathode electrode.



7. The apparatus of claim 1, wherein said anode electrode and said cathode electrode have uniform cross-sections.
8. The apparatus of claim 1, wherein said pulsed electrical discharge is sustained by a plasma created from material removed from said anode electrode and said cathode  
5 electrode.
9. The apparatus of claim 8, wherein said plasma quenches by means of expansion within said gaseous atmosphere.
10. The apparatus of claim 8, wherein said plasma also reacts with said gaseous atmosphere to produce nanopowder compounds including oxides and nitrides.
- 10 11. The apparatus of claim 8, wherein said pulsed electrical discharge occurs in a time period that is short enough to provide inertia confinement of said plasma.
12. The apparatus of claim 8, wherein said gaseous atmosphere is used to control expansion and quench rate of said plasma.
13. The apparatus of claim 8, wherein said anode electrode and said cathode electrode  
15 confine said plasma axially, and said pulsed electrical discharge is of a short duration which provides inertial confinement of said plasma.
14. The apparatus of claim 1, wherein said anode electrode and said cathode electrode are composed of one of aluminum, tantalum, titanium, and zirconium.
15. The apparatus of claim 1, wherein said nanopowders are one of aluminum,  
20 copper,  $\text{Al}_2\text{O}_3$ ,  $\text{TiO}_2$ ,  $\text{TiN}$ ,  $\text{ZiN}$ , and  $\text{Ta}_2\text{N}$ .

16. The apparatus of claim 1, wherein polarities of said anode electrode and said cathode electrode are reversed.
17. The apparatus of claim 1, wherein said nanopowders are comprised of substantially unagglomerated nanopowder of near uniform size.
- 5 18. The apparatus of claim 1, wherein said anode electrode and said cathode electrode are comprised of high melting point materials.
19. The apparatus of claim 1, wherein said gaseous atmosphere is at least one of air, oxygen, nitrogen, and helium.
20. The apparatus of claim 1, wherein said anode electrode and said cathode electrode  
10 are moved toward each other to maintain production rate of said nanopowders.
21. The apparatus of claim 1, wherein said anode electrode and said cathode electrode are located within a chamber filled with said gaseous atmosphere.
22. An apparatus for synthesizing nanopowders, comprising:  
a first hollow ablative body composed of a precursor material and having a first  
15 outer diameter, and further having a first axial bore of a second diameter;  
an anode electrode having a third diameter smaller than said second diameter, and fitted within said first axial bore but electrically isolated from said first hollow ablative body;  
a second hollow ablative body composed of said precursor material and having  
20 said first diameter, and further having a second axial bore of said second diameter;

a cathode electrode having said third diameter and fitted within said second axial bore but electrically isolated from said second hollow ablative body, and wherein said first hollow ablative body and said second hollow ablative body are substantially axially aligned but spaced apart in a gaseous atmosphere; and

5 a power supply which is in electrical communication with said anode electrode and said cathode electrode, and which effects a high power pulsed electrical discharge to ablate said first hollow ablative body and said second hollow ablative body to produce said nanopowders.

10 23. The apparatus of claim 22, wherein said gaseous atmosphere consists of one of an inert gas, a reactive gas, and a mixture of inert and reactive gases.

24. The apparatus of claim 22, wherein said gaseous atmosphere is a mixture of inert gases.

15 25. The apparatus of claim 22, wherein said anode electrode, said cathode electrode, said first hollow ablative body, and said second hollow ablative body are composed of a same material.

26. The apparatus of claim 22, wherein said first hollow ablative body and said second hollow ablative body are composed of a first material, said anode electrode and said cathode electrode are composed of a second material, and said first material is different from said second material.

20 27. The apparatus of claim 22, wherein said first hollow ablative body and said second hollow ablative body are made of nonconducting material, and are without electrical insulation.



28. The apparatus of claim 22, wherein electrical insulation is provided by a first annular insulator placed between said anode electrode and said first hollow ablative body, and by a second annular insulator placed between said cathode electrode and said second hollow ablative body.
- 5 29. The apparatus of claim 22, wherein said first hollow ablative body and said anode electrode form a first composite electrode, said second hollow ablative body and said cathode electrode form a second composite electrode, and said first composite electrode and said second composite electrode radially center said pulsed electrical discharge and substantially prevent axial expansion of a plasma created from ablation of said precursor  
10 material.
30. The apparatus of claim 29, wherein said plasma is of a high temperature and high density to accommodate more rapid quenching by and more rapid reaction with said gaseous atmosphere for improved nanopowder production rates.
31. The apparatus of claim 30, wherein said high temperature is of the order of  
15 50,000°K.
32. The apparatus of claim 29, wherein said pulsed electrical discharge is of a duration short enough to inertially confine said plasma.
33. The apparatus of claim 22, wherein said nanopowders are comprised substantially of unagglomerated nanopowder.
- 20 34. The apparatus of claim 22, wherein said first hollow ablative body, and said second hollow ablative body, are both one of conductor, semiconductor, and nonconductor.

35. A method of more efficiently synthesizing nanopowder, comprising:  
forming a gaseous atmosphere;  
placing a pair of precursor material electrodes of opposite charge and in axial  
alignment, but spaced apart, within said gaseous atmosphere;  
5 generating a high power, pulsed electrical discharge between said pair of  
precursor material electrodes to produce a plasma of high temperature and high density;  
and  
quenching said plasma in said gaseous atmosphere to produce said nanopowder.
36. The method of claim 35, wherein said gaseous atmosphere is a mixture of gases  
10 for quenching said plasma.
37. The method of claim 35, wherein said high power, pulsed electrical discharge is  
of a duration short enough to inertially confine said plasma.
38. The method of claim 35, further comprising physically confining said plasma.
39. The method of claim 35, wherein each of said pair of precursor material  
15 electrodes is fitted within, but electrically isolated from, one of a pair of ablative annular  
bodies.
40. The method of claim 35, further comprising applying said gaseous atmosphere to  
control expansion and quench rates of said plasma.
41. The method of claim 35, further comprising indexing said pair of precursor  
20 material electrodes toward each other.
42. The method of claim 35, wherein said quenching occurs in conjunction with  
reacting said plasma with said gaseous atmosphere.

43. An apparatus for synthesizing nanopowders, comprising:  
a first hollow ablative body composed of a first precursor material and having a first outer diameter, and further having a first axial bore of a second diameter;  
an anode electrode of a second precursor material having a third diameter smaller  
5 than said second diameter, and fitted within said first axial bore but electrically isolated from said first hollow ablative body;  
a second hollow ablative body composed of a third precursor material and having a fourth outer diameter, and further having a second axial bore of a fifth diameter;  
a cathode electrode of a fourth precursor material having a sixth diameter and  
10 fitted within said second axial bore but electrically isolated from said second hollow ablative body, and wherein said first hollow ablative body and said second hollow ablative body are spaced apart in a gaseous atmosphere; and  
a power supply which is in electrical communication with said anode electrode and said cathode electrode, and which effects a high power pulsed electrical discharge to  
15 ablate said first hollow ablative body and said second hollow ablative body to produce said nanopowders.
44. The apparatus of claim 43, wherein said gaseous atmosphere consists of one of an inert gas, a reactive gas, and a mixture of inert and reactive gases.
45. The apparatus of claim 43, wherein said gaseous atmosphere is a mixture of inert  
20 gases.
46. The apparatus of claim 43, wherein said anode electrode, said cathode electrode, said first hollow ablative body, and said second hollow ablative body are composed of the same material.



47. The apparatus of claim 43, wherein said first hollow ablative body and said second hollow ablative body are composed of a first material, said anode electrode and said cathode electrode are composed of a second material, and said first material is different from said second material.
- 5 48. The apparatus of claim 43, wherein said first hollow ablative body and said second hollow ablative body are made of nonconducting material, and are without electrical insulation.
49. The apparatus of claim 43, wherein electrical insulation is provided by a first annular insulator placed between said anode electrode and said first hollow ablative body,  
10 and by a second annular insulator placed between said cathode electrode and said second hollow ablative body.
50. The apparatus of claim 43, wherein said pulsed electrical discharge is of a duration short enough to inertially confine said plasma.
51. The apparatus of claim 43, wherein said plasma is of a high temperature and high  
15 density to accommodate more rapid quenching by and more rapid reaction with said gaseous atmosphere for improved nanopowder production rates.
52. The apparatus of claim 51, wherein said high temperature is of the order of 50,000°K.
53. The apparatus of claim 43, wherein said nanopowders are comprised substantially  
20 of unagglomerated nanopowder.

54. The apparatus of claim 43, wherein said first hollow ablative body, and said second hollow ablative body, are both one of conductor, semiconductor, and nonconductor.
55. The apparatus of claim 43, wherein said first outer diameter is the same as said  
5 fourth outer diameter.
56. The apparatus of claim 43, wherein said second diameter is the same as said fifth diameter.
57. The apparatus of claim 43, wherein said third diameter is the same as said sixth diameter.
- 10 58. The apparatus of claim 43, wherein said first precursor material is the same as said third precursor material.
59. The apparatus of claim 43, wherein said second precursor material is the same as said fourth precursor material.
60. The apparatus of claim 43, wherein:  
15 said first outer diameter is the same as said fourth outer diameter;  
said second diameter is the same as said fifth diameter;  
said third diameter is the same as said sixth diameter;  
said first precursor material is the same as said third precursor material; and  
said second precursor material is the same as said fourth precursor material.

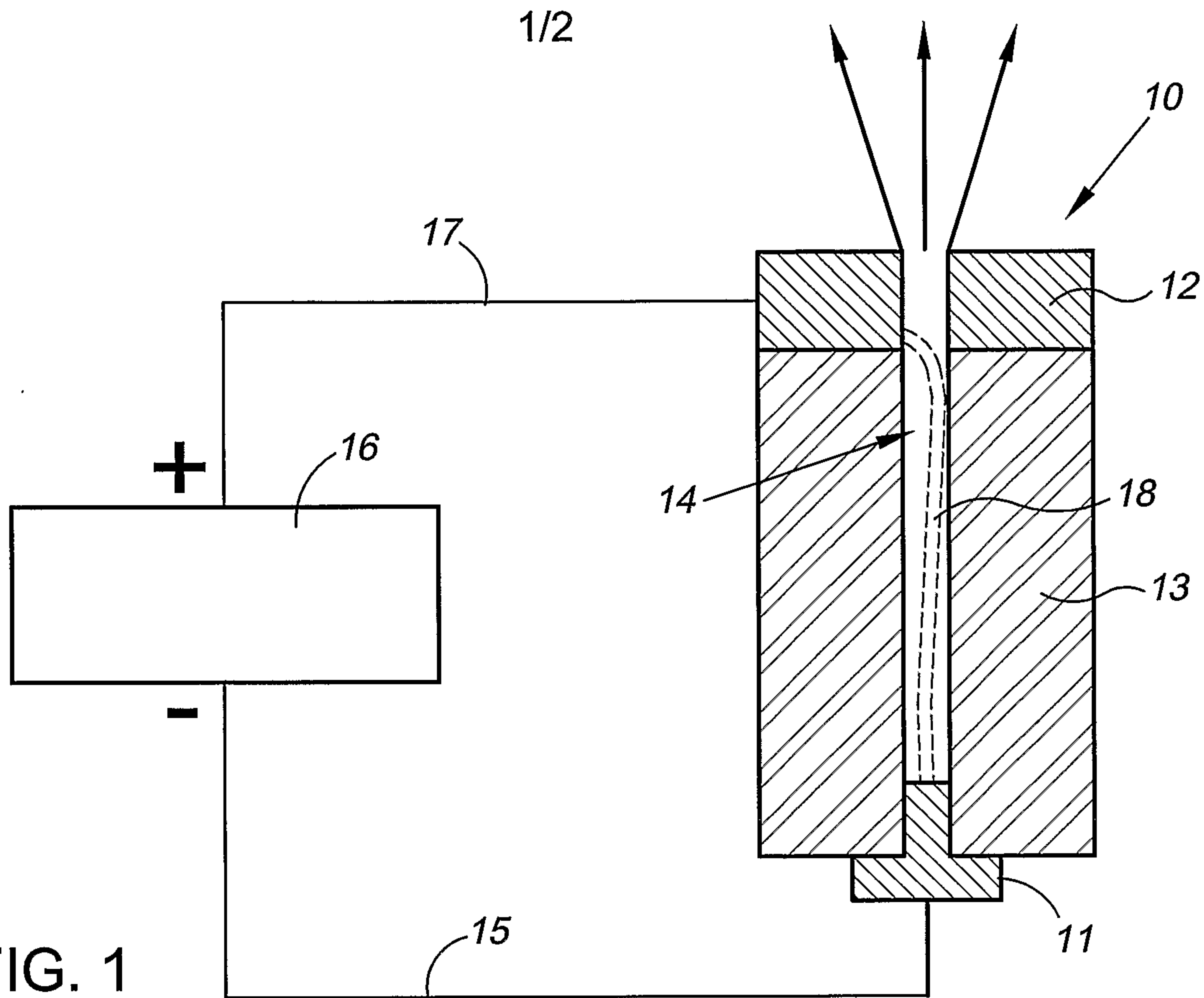

FIG. 1  
PRIOR ART

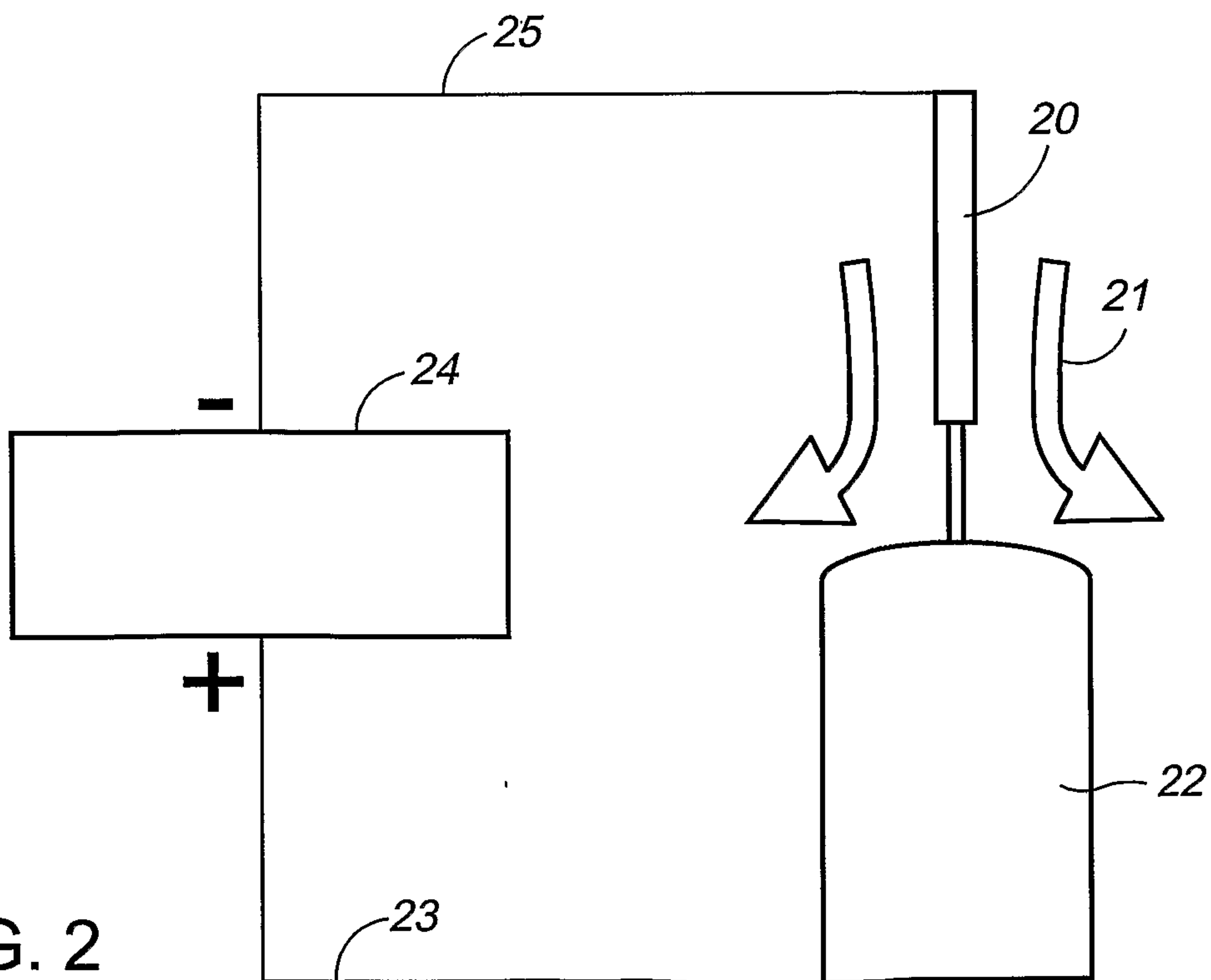

FIG. 2  
PRIOR ART



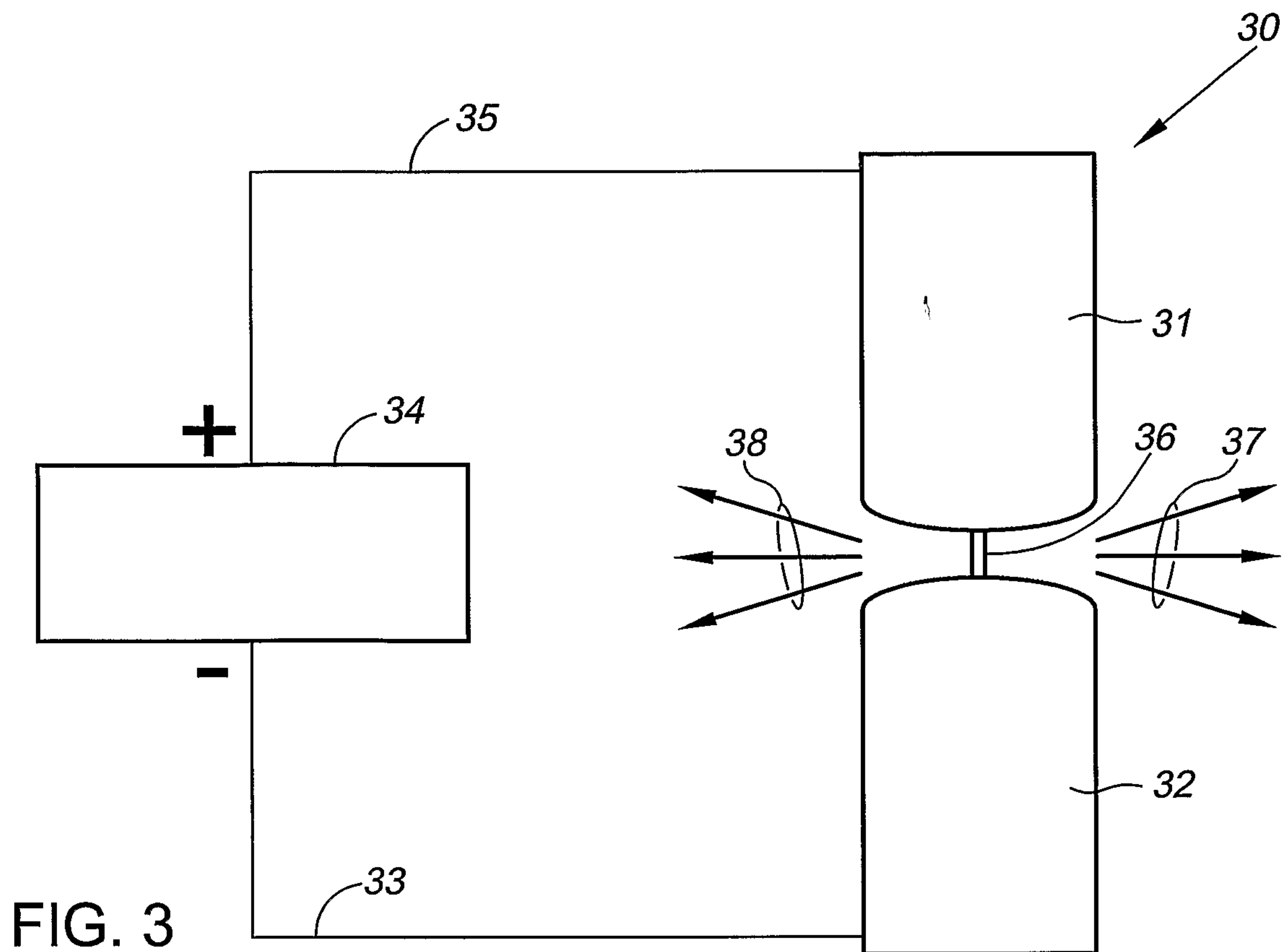

FIG. 3

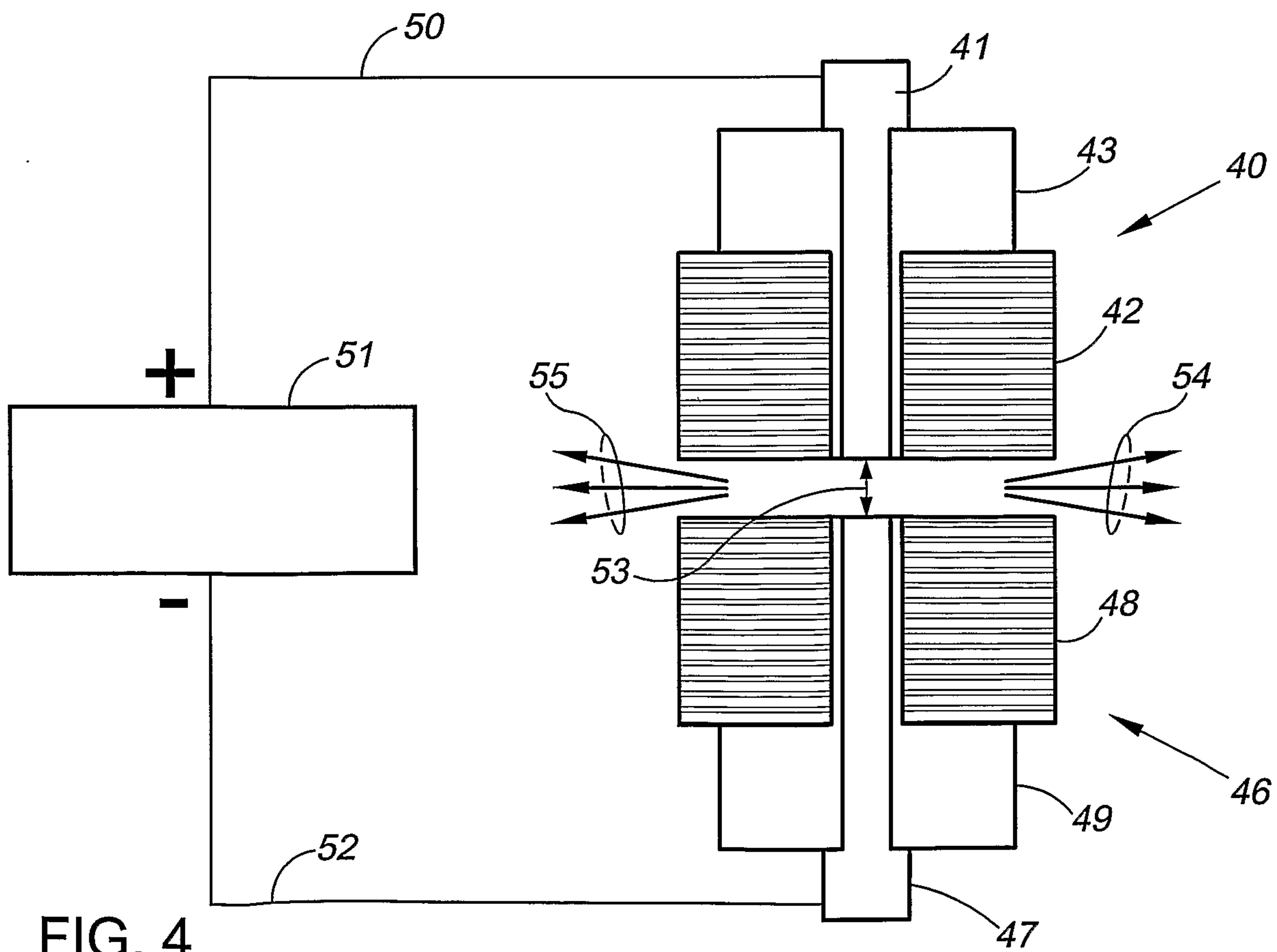

FIG. 4

