

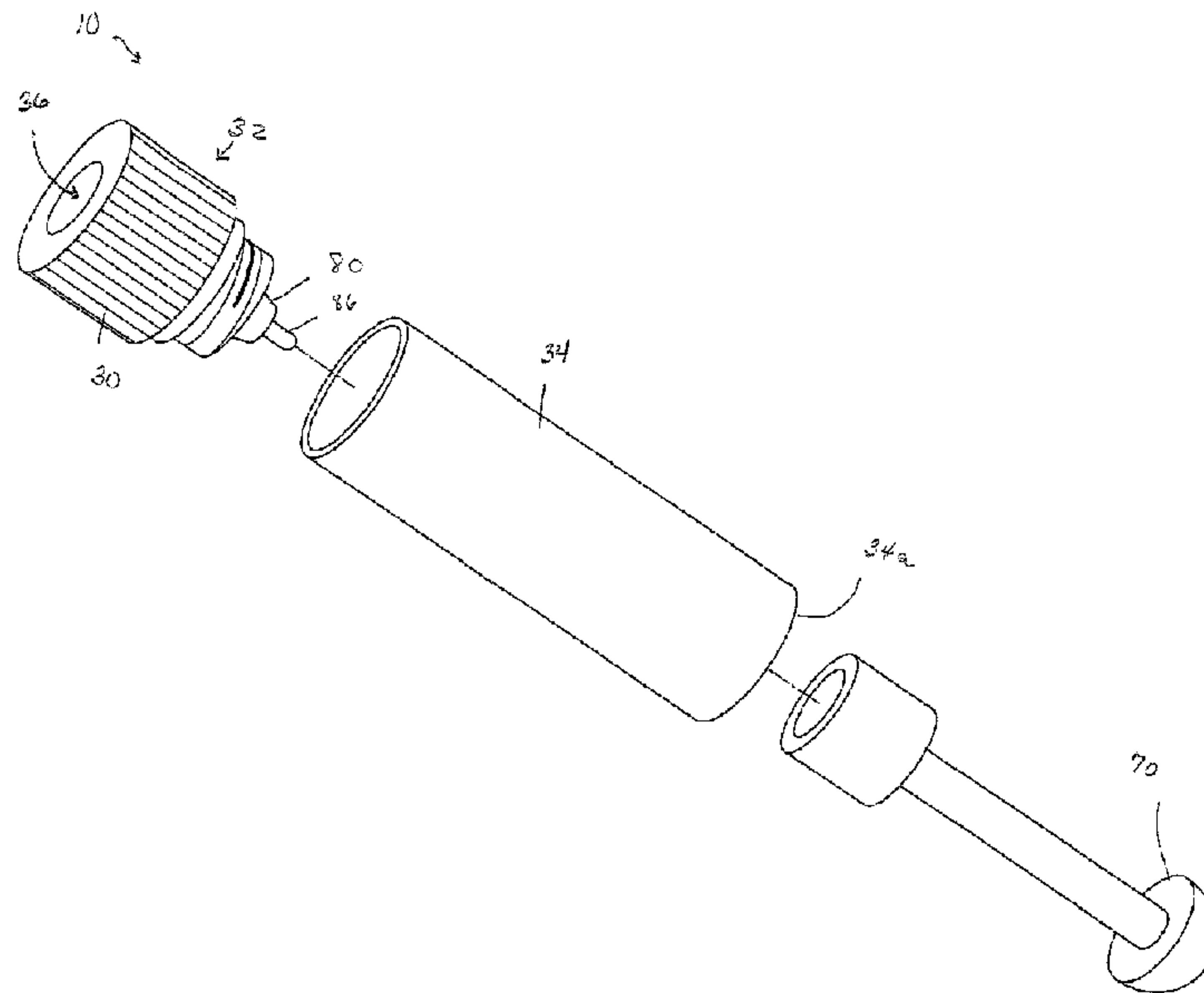

(86) Date de dépôt PCT/PCT Filing Date: 2014/04/14
 (87) Date publication PCT/PCT Publication Date: 2014/10/23
 (45) Date de délivrance/Issue Date: 2018/07/10
 (85) Entrée phase nationale/National Entry: 2015/10/09
 (86) N° demande PCT/PCT Application No.: US 2014/033927
 (87) N° publication PCT/PCT Publication No.: 2014/172239
 (30) Priorité/Priority: 2013/04/15 (US61/811,918)

(51) Cl.Int./Int.Cl. *A61B 5/15* (2006.01),
A61B 5/153 (2006.01), *A61B 5/155* (2006.01),
A61B 5/157 (2006.01), *B01L 3/00* (2006.01),
G01N 33/49 (2006.01), *G01N 33/50* (2006.01)
 (72) Inventeurs/Inventors:
 ELLIS, ROBERT G., US;
 WILKINSON, BRADLEY M., US
 (73) Propriétaire/Owner:
 BECTON, DICKINSON AND COMPANY, US
 (74) Agent: PIASETZKI NENNIGER KVAS LLP

(54) Titre : DISPOSITIF DE COLLECTE DE FLUIDE BIOLOGIQUE ET SYSTEME DE SEPARATION ET D'ANALYSE DE FLUIDE BIOLOGIQUE
 (54) Title: BIOLOGICAL FLUID COLLECTION DEVICE AND BIOLOGICAL FLUID SEPARATION AND TESTING SYSTEM



(57) **Abrégé/Abstract:**

A biological fluid collection device that is adapted to receive a blood sample having a cellular portion and a plasma portion is disclosed. After collection of the blood sample, the plasma portion is separated from the cellular portion. After separation, the biological fluid collection device is able to transfer the plasma portion of the blood sample to a point-of-care testing device. The biological fluid collection device also provides a closed sampling and transfer system that reduces the exposure of a blood sample and provides fast mixing of a blood sample with a sample stabilizer. The biological fluid collection device is engageable with a biological fluid testing device for closed transfer of a portion of the plasma portion from the biological fluid collection device to the biological fluid testing device. The biological fluid testing device is adapted to receive the plasma portion to analyze the blood sample.

(12) INTERNATIONAL APPLICATION PUBLISHED UNDER THE PATENT COOPERATION TREATY (PCT)

(19) World Intellectual Property
Organization
International Bureau(10) International Publication Number
WO 2014/172239 A1(43) International Publication Date
23 October 2014 (23.10.2014)**(51) International Patent Classification:**

A61B 5/15 (2006.01) *G01N 33/50* (2006.01)
A61B 5/153 (2006.01) *A61B 5/157* (2006.01)
G01N 33/49 (2006.01) *A61B 5/155* (2006.01)
B01L 3/00 (2006.01)

(21) International Application Number:

PCT/US2014/033927

(22) International Filing Date:

14 April 2014 (14.04.2014)

(25) Filing Language:

English

(26) Publication Language:

English

(30) Priority Data:

61/811,918 15 April 2013 (15.04.2013) US

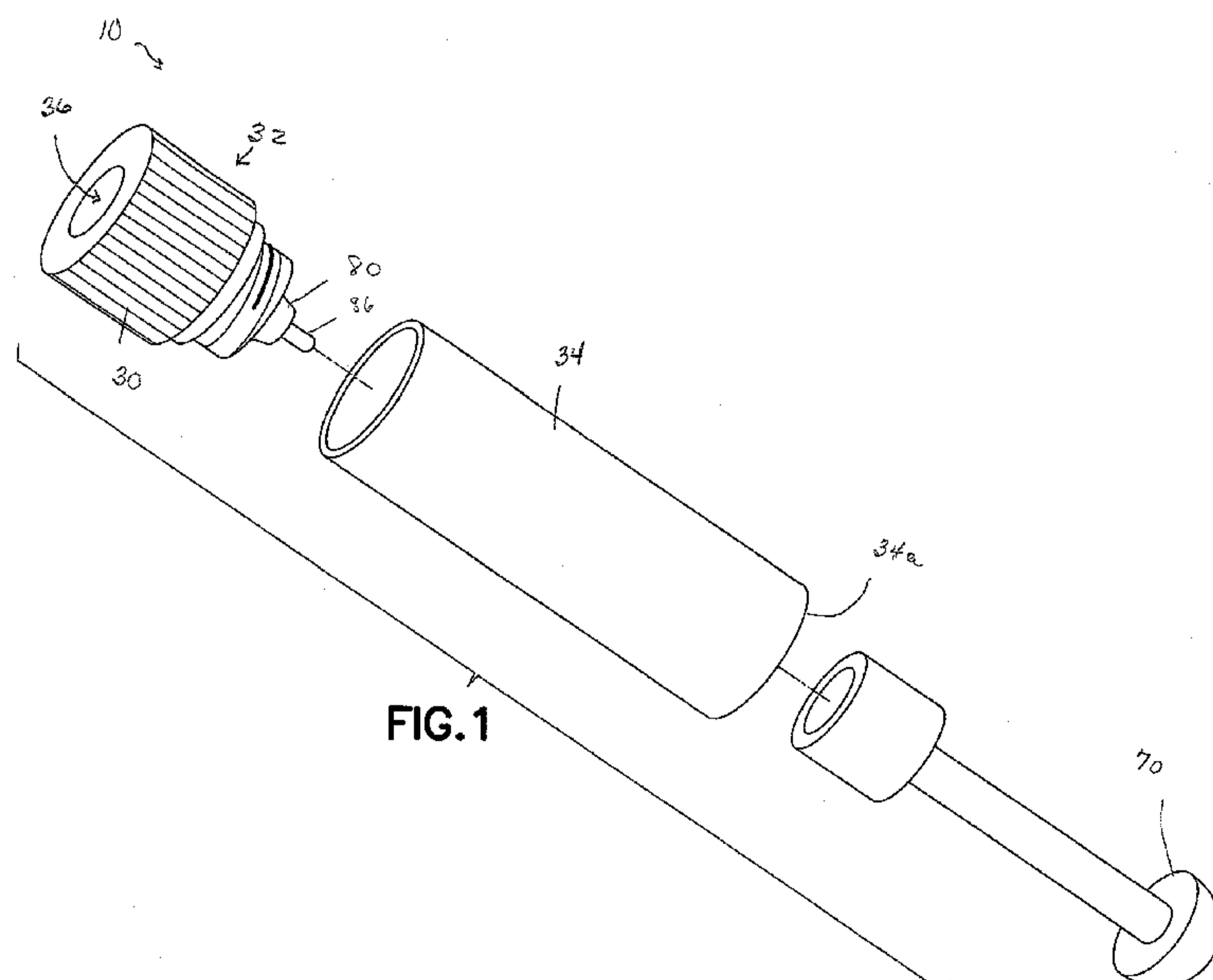
(71) Applicant: BECTON, DICKINSON AND COMPANY
[US/US]; One Becton Drive, Franklin Lakes, New Jersey 07417 (US).**(72) Inventors: ELLIS, Robert, G.;** 177 Linden Road, Wayne, New Jersey 07470 (US). **WILKINSON, Bradley, M.;** 39 Hillside Drive, North Haledon, New Jersey 07508 (US).**(74) Agents: MILES, Kirk, M. et al.;** The Webb Law Firm, One Gateway Center, 420 Fort Duquesne Boulevard, Suite 1200, Pittsburgh, Pennsylvania 15222 (US).**(81) Designated States** (*unless otherwise indicated, for every kind of national protection available*): AE, AG, AL, AM, AO, AT, AU, AZ, BA, BB, BG, BH, BN, BR, BW, BY, BZ, CA, CH, CL, CN, CO, CR, CU, CZ, DE, DK, DM, DO, DZ, EC, EE, EG, ES, FI, GB, GD, GE, GH, GM, GT, HN, HR, HU, ID, IL, IN, IR, IS, JP, KE, KG, KN, KP, KR, KZ, LA, LC, LK, LR, LS, LT, LU, LY, MA, MD, ME, MG, MK, MN, MW, MX, MY, MZ, NA, NG, NI, NO, NZ, OM, PA, PE, PG, PH, PL, PT, QA, RO, RS, RU, RW, SA, SC, SD, SE, SG, SK, SL, SM, ST, SV, SY, TH, TJ, TM, TN, TR, TT, TZ, UA, UG, US, UZ, VC, VN, ZA, ZM, ZW.**(84) Designated States** (*unless otherwise indicated, for every kind of regional protection available*): ARIPO (BW, GH, GM, KE, LR, LS, MW, MZ, NA, RW, SD, SL, SZ, TZ, UG, ZM, ZW), Eurasian (AM, AZ, BY, KG, KZ, RU, TJ, TM), European (AL, AT, BE, BG, CH, CY, CZ, DE, DK, EE, ES, FI, FR, GB, GR, HR, HU, IE, IS, IT, LT, LU, LV, MC, MK, MT, NL, NO, PL, PT, RO, RS, SE, SI, SK, SM, TR), OAPI (BF, BJ, CF, CG, CI, CM, GA, GN, GQ, GW, KM, ML, MR, NE, SN, TD, TG).**Published:**— *with international search report (Art. 21(3))***(54) Title: BIOLOGICAL FLUID COLLECTION DEVICE AND BIOLOGICAL FLUID SEPARATION AND TESTING SYSTEM****(57) Abstract:** A biological fluid collection device that is adapted to receive a blood sample having a cellular portion and a plasma portion is disclosed. After collection of the blood sample, the plasma portion is separated from the cellular portion. After separation, the biological fluid collection device is able to transfer the plasma portion of the blood sample to a point-of-care testing device. The biological fluid collection device also provides a closed sampling and transfer system that reduces the exposure of a blood sample and provides fast mixing of a blood sample with a sample stabilizer. The biological fluid collection device is engageable with a biological fluid testing device for closed transfer of a portion of the plasma portion from the biological fluid collection device to the biological fluid testing device. The biological fluid testing device is adapted to receive the plasma portion to analyze the blood sample.

BIOLOGICAL FLUID COLLECTION DEVICE AND BIOLOGICAL FLUID SEPARATION AND TESTING SYSTEM

BACKGROUND OF THE INVENTION

1. Field of the Disclosure

[0001] The present disclosure relates generally to devices, assemblies, and systems adapted for use with vascular access devices. More particularly, the present disclosure relates to devices, assemblies, and systems adapted for collecting biological samples for use in point-of-care testing.

2. Description of the Related Art

[0002] Blood sampling is a common health care procedure involving the withdrawal of at least a drop of blood from a patient. Blood samples are commonly taken from hospitalized, homecare, and emergency room patients either by finger stick, heel stick, or venipuncture. Blood samples may also be taken from patients by venous or arterial lines. Once collected, blood samples may be analyzed to obtain medically useful information including chemical composition, hematology, or coagulation, for example.

[0003] Blood tests determine the physiological and biochemical states of the patient, such as disease, mineral content, drug effectiveness, and organ function. Blood tests may be performed in a clinical laboratory or at the point-of-care near the patient. One example of point-of-care blood testing is the routine testing of a patient's blood glucose levels which involves the extraction of blood via a finger stick and the mechanical collection of blood into a diagnostic cartridge. Thereafter, the diagnostic cartridge analyzes the blood sample and provides the clinician a reading of the patient's blood glucose level. Other devices are available which analyze blood gas electrolyte levels, lithium levels, and ionized calcium levels. Some other point-of-care devices identify markers for acute coronary syndrome (ACS) and deep vein thrombosis/pulmonary embolism (DVT/PE).

[0004] Despite the rapid advancement in point-of-care testing and diagnostics, blood sampling techniques have remained relatively unchanged. Blood samples are frequently drawn using hypodermic needles or vacuum tubes attached to a proximal end of a needle or a catheter assembly. In some instances, clinicians collect blood from a catheter assembly using a needle and syringe that is inserted into the catheter to withdraw blood from a patient through the inserted catheter. These procedures utilize needles and vacuum tubes as intermediate devices from which the collected blood sample is typically withdrawn prior to testing. These processes

are thus device intensive, utilizing multiple devices in the process of obtaining, preparing, and testing blood samples. Each additional device increases the time and cost of the testing process.

[0005] Point-of-care testing devices allow for a blood sample to be tested without needing to send the blood sample to a lab for analysis. Thus, it is desirable to create a device that provides an easy, safe, reproducible, and accurate process with a point-of-care testing system.

SUMMARY OF THE INVENTION

[0006] The present disclosure provides a biological fluid collection device, such as a blood collection device, that is adapted to receive a multi-component blood sample having a cellular portion and a plasma portion. After collecting the blood sample, the biological fluid collection device is able to separate the plasma portion from the cellular portion. After separation, the biological fluid collection device is able to transfer the plasma portion of the blood sample to a point-of-care testing device. The biological fluid collection device of the present disclosure also provides a closed sampling and transfer system that reduces the exposure of a blood sample and provides fast mixing of a blood sample with a sample stabilizer or preservative. The sample stabilizer or preservative, can be an anticoagulant, or a substance designed to preserve a specific element within the blood such as, for example, RNA, protein analyte, or other element. The biological fluid collection device is engageable with a biological fluid testing device, such as a blood testing device, for closed transfer of a portion of the plasma portion from the biological fluid collection device to the biological fluid testing device. The biological fluid testing device is adapted to receive the plasma portion to analyze the blood sample and obtain test results.

[0007] Some of the advantages of the biological fluid collection device and the biological fluid separation and testing system of the present disclosure over prior systems are that it is a closed system which reduces blood sample exposure, it provides passive and fast mixing of the blood sample with a sample stabilizer, it facilitates separation of the blood sample without transferring the blood sample to a separate device, and it is capable of transferring pure plasma to a point-of-care testing device. The biological fluid collection device of the present disclosure enables integrated blood collection and plasma creation in a closed system without centrifugation. The clinician may collect and separate the blood sample and then immediately transfer the plasma portion to the point-of-care testing device without further manipulation. This enables collection and transfer of plasma to the point-of-care testing device without exposure to blood. In addition, the biological fluid collection device of the present disclosure minimizes process time by processing the blood within the biological fluid collection device

and without external machinery. Further, for tests which only require small amounts of blood, it eliminates the waste associated with blood collection and plasma separation with an evacuated tube.

[0008] In accordance with an embodiment of the present invention, a biological fluid collection device adapted to receive a multi-component blood sample includes a housing defining a first chamber having a first chamber inlet and a first chamber outlet, and a second chamber having a second chamber inlet. The housing also includes a separation member disposed between the first chamber outlet and the second chamber inlet. The first chamber outlet is in communication with the second chamber inlet via the separation member, and the first chamber is adapted to receive the multi-component blood sample. The device also includes an actuator member associated with the second chamber. Actuation of the actuator member in a first direction draws a component of the multi-component blood sample from the first chamber through the separation member to the second chamber.

[0009] In certain configurations, the separation member is adapted to allow the component to pass through the separation member to the second chamber. The component may be a plasma component. The device may also include a septum engaged with the housing to seal the first chamber inlet of the first chamber. The device may also include a valve engaged with the second chamber to seal the second chamber. The valve may be transitionable between a closed position in which the second chamber is fully sealed and an open position in which the second chamber is open.

[0010] In other configurations, the valve is engageable with a receiving port of a testing device for closed transfer of at least a portion of the component from the second chamber to the testing device. The component may be a plasma component. The valve may also transition from the closed position to the open position via engagement with the receiving port of the testing device. The testing device may be a point-of-care testing device. The valve may be a spring-loaded dispensing valve.

[0011] In certain configurations, the housing may include a tubular member removably engaged therewith. The actuator member may be disposable at least partially within the tubular member and the actuator member may be removably engaged with the housing. The tubular member and the actuator member may be removable from the housing after passage of at least a portion of the component from the first chamber into the second chamber. The component may be a plasma component. The device may also include a valve engaged with the second chamber to seal the second chamber. The valve may be transitionable between a closed position in which the second chamber is fully sealed, and an open position in which the second

chamber is open. Transition from the closed position to the open position may occur after the tubular member and the actuator member are removed from the housing. The actuator member may include a plunger. The housing may include a sample stabilizer.

[0012] In accordance with another embodiment of the present invention, a biological fluid sample separation and testing system, such as a blood sample separation and testing system, for a multi-component blood sample includes a biological fluid collection and separation device, such as a blood collection and separation device. The biological fluid collection and separation device includes a housing defining a first chamber having a first chamber inlet and a first chamber outlet, and a second chamber having a second chamber inlet. The device also includes a separation member disposed between the first chamber outlet and the second chamber inlet. The first chamber is adapted to receive the multi-component blood sample. The system also includes a valve engaged with the second chamber to seal the second chamber. The valve is transitionable between a closed position in which the second chamber is fully sealed, and an open position in which the second chamber is open. The system also includes a testing device having a receiving port adapted to engage the valve of the biological fluid collection and separation device. The valve may be transitioned from the closed position to the open position when the receiving port is engaged with the valve.

[0013] In certain configurations, the housing includes a tubular member removably engaged therewith and transition of the valve from the closed position to the open position occurs after the tubular member is removed from the housing. The separation member may be adapted allow a component of the multi-component blood sample to pass through the separation member to the second chamber. The component may be a plasma component. Optionally, the biological fluid sample separation and testing system may include a septum engaged with the housing to seal the first chamber inlet of the first chamber. The valve may be engageable with the receiving port of the testing device for closed transfer of at least a portion of a component from the second chamber to the testing device. The component may be a plasma component and the valve may be a spring-loaded dispensing valve.

[0014] The housing may include a tubular member which is removable from the housing after passage of at least a portion of a component of the multi-component blood sample from the first chamber into the second chamber. The component may be a plasma component. The system may also include an actuator member associated with the housing. Actuation of the actuator member in a first direction may draw a component from the first chamber through the separation member to the second chamber. The component may be a plasma component.

BRIEF DESCRIPTION OF THE DRAWINGS

[0015] The above-mentioned and other features and advantages of this disclosure, and the manner of attaining them, will become more apparent and the disclosure itself will be better understood by reference to the following descriptions of embodiments of the disclosure taken in conjunction with the accompanying drawings, wherein:

[0016] **Fig. 1** is an exploded, perspective view of a biological fluid collection device in accordance with an embodiment of the present invention.

[0017] **Fig. 2** is an assembled, perspective view of a biological fluid collection device in accordance with an embodiment of the present invention, with an actuator member in a first position.

[0018] **Fig. 3** is a perspective view of a biological fluid collection device in accordance with an embodiment of the present invention, with a biological fluid collection device and a non-patient needle interface.

[0019] **Fig. 4** is a perspective view of a biological fluid collection device in accordance with an embodiment of the present invention, with an actuator member in a second position.

[0020] **Fig. 5** is a cross-sectional view of the biological fluid collection device engaged with a tube holder in accordance with an embodiment of the present invention.

[0021] **Fig. 6** is a sectional view of the separation member portion of the biological fluid collection device of **Fig. 5** in accordance with an embodiment of the present invention, with the separation member separating a plasma portion of a blood sample from a cellular portion of the blood sample.

[0022] **Fig. 7** is a perspective view of a biological fluid collection device and a point-of-care testing device in accordance with an embodiment of the present invention.

[0023] **Fig. 8** is a cross-sectional view of a valve of a biological fluid collection device in accordance with an embodiment of the present invention, with the valve in a closed position.

[0024] **Fig. 9** is a cross-sectional view of a valve of a biological fluid collection device in accordance with an embodiment of the present invention, with the valve in an open position.

[0025] **Fig. 10** is a perspective view of a valve of a biological fluid collection device in accordance with another embodiment of the present invention.

[0026] **Fig. 11** is a cross-sectional view of a valve of a biological fluid collection device in accordance with another embodiment of the present invention, with the valve in a closed position.

[0027] Fig. 12 is a cross-sectional view of a valve of a biological fluid collection device in accordance with another embodiment of the present invention, with the valve in an open position.

[0028] Corresponding reference characters indicate corresponding parts throughout the several views. The exemplifications set out herein illustrate exemplary embodiments of the disclosure, and such exemplifications are not to be construed as limiting the scope of the disclosure in any manner.

DETAILED DESCRIPTION

[0029] The following description is provided to enable those skilled in the art to make and use the described embodiments contemplated for carrying out the invention. Various modifications, equivalents, variations, and alternatives, however, will remain readily apparent to those skilled in the art. Any and all such modifications, variations, equivalents, and alternatives are intended to fall within the spirit and scope of the present invention.

[0030] For purposes of the description hereinafter, the terms “upper”, “lower”, “right”, “left”, “vertical”, “horizontal”, “top”, “bottom”, “lateral”, “longitudinal”, and derivatives thereof shall relate to the invention as it is oriented in the drawing figures. However, it is to be understood that the invention may assume alternative variations and step sequences, except where expressly specified to the contrary. It is also to be understood that the specific devices and processes illustrated in the attached drawings, and described in the following specification, are simply exemplary embodiments of the invention. Hence, specific dimensions and other physical characteristics related to the embodiments disclosed herein are not to be considered as limiting.

[0031] Various point-of-care testing devices are known in the art. Such point-of-care testing devices include test strips, glass slides, diagnostic cartridges, or other testing devices for testing and analysis. Test strips, glass slides, and diagnostic cartridges are point-of-care testing devices that receive a blood sample and test that blood for one or more physiological and biochemical states. There are many point-of-care devices that use cartridge based architecture to analyze very small amounts of blood bedside without the need to send the sample to a lab for analysis. This saves time in getting results over the long run but creates a different set of challenges versus the highly routine lab environment. Examples of such testing cartridges include the i-STAT® testing cartridge from the Abbot group of companies. Testing cartridges such as the i-STAT® cartridges may be used to test for a variety of conditions including the

presence of chemicals and electrolytes, hematology, blood gas concentrations, coagulation, or cardiac markers. The results of tests using such cartridges are quickly provided to the clinician.

[0032] However, the samples provided to such point-of-care testing cartridges are currently manually collected with an open system and transferred to the point-of-care testing cartridge in a manual manner that often leads to inconsistent results, thereby negating the advantage of the point-of-care testing device. Accordingly, a need exists for a system for collecting and transferring a sample to a point-of-care testing device that provides safer, reproducible, and more accurate results. Accordingly, a point-of-care collecting and transferring system of the present disclosure will be described hereinafter. A system of the present disclosure enhances the reliability of the point-of-care testing device by: 1) incorporating a more closed type of sampling and transfer system; 2) minimizing open exposure of the sample; 3) improving sample quality; 4) improving the overall ease of use; and 5) separating the sample at the point of collection.

[0033] Reference is now made to **Figs. 1-12** which illustrate a biological fluid collection device, such as a blood collection device, generally indicated as **10**, in accordance with an embodiment of the present invention. The blood collection device **10** is configured to collect a multi-component blood sample **12**, separate the sample, and supply a portion of the sample to a point-of-care testing device. Specifically, the blood collection device **10** is adapted to receive the multi-component blood sample **12** having a first portion or cellular portion **14** and a second portion or plasma portion **16**. After collecting the blood sample **12**, the blood collection device **10** is able to separate the plasma portion **16** from the cellular portion **14**. After separation, the blood collection device **10** is able to transfer the plasma portion **16** of the blood sample **12** to a point-of-care testing device **22**, as shown in **Figs. 7-9** and **12**. The blood collection device **10** of the present disclosure also provides a closed separation system that reduces the exposure of a blood sample and provides fast mixing of a blood sample with a sample stabilizer or preservative **18**, as illustrated in **Fig. 6**.

[0034] It can be appreciated that the sample stabilizer or preservative **18** can include any one or more of an anticoagulant or a substance, well known in the art that can be used to preserve a specific element within a blood sample, such as RNA, a protein analyte, and the like.

[0035] Referring in particular to **Fig. 7**, there is shown an exemplary embodiment of a biological fluid separation and testing system, such as a blood separation and testing system, generally indicated as **20**, of the present disclosure which includes the blood collection device **10** and the blood testing device or point-of-care testing device **22** engageable with the blood

collection device 10 for closed transfer of a portion of the plasma portion 16 (Fig. 6) from the blood collection device 10 to the blood testing device 22. The blood testing device 22 is adapted to receive the plasma portion 16 to analyze the blood sample and obtain test results.

[0036] Referring in particular to Figs. 1-6, there is shown the biological fluid or blood collection device 10 which is adapted to receive the multi-component blood sample 12 having a cellular portion 14 and a plasma portion 16. The blood collection device 10 includes a housing 30 defining a first chamber 40 having a first chamber inlet 42 and a first chamber outlet 44, and a second chamber 50 having a second chamber inlet 52 and a second chamber outlet 54. The housing 30 further includes a separation member, such as a filter 60, disposed between the first chamber outlet 44 and the second chamber inlet 52 such that the first chamber outlet 44 is in communication with the second chamber inlet 52 via the filter 60. The first chamber 40 is adapted to receive the multi-component blood sample 12. An actuator member 70 is associated with the second chamber 50 such that actuation of the actuator member 70 in a first direction or proximal direction "P", as shown in Figs. 4 and 5, draws the plasma portion 16 from the first chamber 40 through the filter 60 to the second chamber 50. The actuator member 70 can be in the form of a piston arrangement or plunger, which the clinician can employ, to provide a motivating force for the separation process of the plasma portion 16 from the cellular portion 14.

[0037] According to one embodiment, the blood collection device 10 can have an appearance which is similar to the commonly used Vacutainer™ tube manufactured by Becton, Dickinson and Company. More specifically, the blood collection device 10 can include a cap portion, generally indicated as 32 that defines the housing 30 having an appearance similar to a Hemogard™ cap also manufactured by Becton, Dickinson and Company. The housing 30 can have a tubular member 34 engaged therewith. According to one embodiment, the tubular member 34 can have an appearance similar to the tube portion of the Vacutainer™ tube.

[0038] As shown in Figs. 1 and 5, the tubular member 34 can be removably engaged with the housing 30/cap 32. According to one embodiment, a first threaded connection 38 can be provided between the tubular member 34 and the cap 32 defining the housing 30. The actuator member 70 can be disposed at least partially within the tubular member 34 and the actuator member 70 can be removably engaged with the housing 30/cap 32 by a second threaded connection 39. The tubular member 34 can be threaded onto a main body of the cap portion 32 while the actuator member 70 can be threaded onto a valve 80 or piston arrangement located within the housing 30/cap 32. The first and second threaded connections 38, 39 enable the tubular member 34 and the actuator member 70 to be removed from the housing 30/cap 32 after

passage of at least a portion of the plasma portion **16** from the first chamber **40** into the second chamber **50**.

[0039] With continuing references to **Figs. 1-5**, the cap portion **32** of the device **10** includes a rubber stopper **36** or septum, similar to the Hemoguard™ stopper, engaged with the housing **30** to seal the first chamber inlet **42** of the first chamber **40**. The housing **30** for separating the plasma portion **16** from the cellular portion **14** is located under the stopper **36**, and employs one of various possible filtration technologies to separate the plasma portion **16** from the cellular portion **14** of the multi-component blood sample **12**.

[0040] As illustrated in **Fig. 3**, because the blood collection device **10** has a rubber stopper **36** with the same dimensions as a Vacutainer™ tube, this device **10** would similarly interface with any standard non-patient (NP) needle type interface, as generally shown by **90**. Examples of NP needle interfaces would be a tube holder **92** with a finger grip luer adapter (FGLA) attached, with a luer lock access device (LLAD) attached, or with a blood transfer device (BTD) attached, all of which are known in the art and have a standard NP needle interface having a needle covered by a collapsible rubber sleeve. The NP needle interface can be attached to a standard needle assembly/blood collection set, as generally indicated by **94**.

[0041] With particular reference to **Fig. 6**, according to one design, the filter **60** is adapted to trap the cellular portion **14** in the first chamber **40** and allow the plasma portion **16** to pass through the filter **60** to the second chamber **50**. In one embodiment, the filter **60** may be either hollow fiber membrane filters commercially available, or flat membrane filters, such as track-edge filters commercially available. Membrane filter pore size and porosity can be chosen to optimize separation of clean (i.e., red blood cell free, white blood cell free, and platelet free) plasma **16** in an efficient manner. In another embodiment, the filter **60** can include a lateral flow membrane. In other embodiments, the filter **60** may comprise any filter that is able to trap the cellular portion **14** of the blood sample **12** in the first chamber **40** and allow the plasma portion **16** of the blood sample **12** to pass through the filter **60** to the second chamber **50**.

[0042] With continuing reference to **Figs. 5-6** and with reference to **Figs. 8-9** and **11-12**, a dispensing valve **80, 80a, 80b** is engaged with the second chamber **50** to seal the second chamber outlet **54**. The valve **80, 80a, 80b** is transitionable between a closed position, such as shown in **Figs. 8** and **11**, in which the second chamber **50** is fully sealed and an open position, such as shown in **Figs. 9** and **12**, in which the second chamber **50** is open.

[0043] As shown in **Figs. 7-9** and **12**, when the valve **80, 80a, 80b** is engaged with a receiving port **24** of a testing device, such as a point-of-care testing device **22**, closed transfer

of at least a portion of the plasma portion 16 from the second chamber 50 to the testing device 22 occurs. Specifically, the valve 80, 80a, 80b can be configured to transition from the closed position to the open position via engagement with the receiving port 24 of the testing device 22. This transition from the closed position to the open position occurs after the tubular member 34 and the actuator member 70 are removed from the housing 30.

[0044] According to one embodiment, as shown in Figs. 8-9, the valve 80a can be a universal delivery valve having a design wherein the plasma portion 16 is dispensed into the point of care testing device 22 when the cap 32 is pushed in a distal direction "D". Applying the distal force "D" to the cap causes a transfer device, such as a needle cannula 82, to penetrate a sealing member 84, which seals the second chamber 50 of the housing, and allows the plasma portion to flow therethrough and into the testing device 22.

[0045] According to another design, as shown in Figs. 10-12, the dispensing valve 80b may be similar to a Schrader type valve or may be of some other design where the plasma would be dispensed into the point-of-care testing device 22 when a force in the distal direction "D" is applied to the cap 32. The dispensing valve 80b includes a valve stem 86 biased by a spring 88 so that application of a force to the cap 32 in the distal direction "D" causes an end 86a of the valve stem to contact the receiving port 24 of the point-of-care testing device 22. This force results in a compressive force "C" being applied to the valve stem 86 so that the spring 88 compresses and a valve cap 86b of the dispensing valve 80b enters into the second chamber 50 so that the second chamber outlet 54 opens up, as shown in Fig. 12, allowing the plasma portion 16 to flow therethrough and into the receiving port 24 of the point-of-care testing device 22.

[0046] The housing 30 of the biological fluid collection device 10 may also include a sample stabilizer or preservative 18. The sample stabilizer 18, can be an anticoagulant, or a substance designed to preserve a specific element within the blood such as, for example, RNA, protein analyte, or other element. In one embodiment, a layer of sample stabilizer 18 may be disposed adjacent a wall portion of the first chamber 40 or within the first chamber inlet 42. In other embodiments, the sample stabilizer 18 may be located adjacent the filter 60 or any other area of the blood collection device 10 in which it contacts a biological sample.

[0047] With reference to Figs. 3-4, the operation of the device 10 is as follows: 1) Initially, a blood collection set 94 of choice, such as a needle/hub type or a wing set type is attached to one of the NP needle interfaces 90 discussed above; 2) Next, the patient is stuck with a needle 96 of the blood collection set 94; 3) Instead of using an evacuated tube such as the Vacutainer™ tube, the biological fluid collection device 10 of the invention is inserted into the holder 92 into contact with the NP needle interface 90. A small volume of blood would be drawn from the

patient into the first chamber 40 of the housing 30 of the device 10; 4) Thereafter, the device 10 is removed from the holder 92; 5) Then, the clinician applies a pulling or proximal force "P" on the actuator member/plunger rod 70 extending through an end portion 34a of the tubular member 34, as shown in Fig. 4. This action causes the multi-component blood sample 12 to be pulled through the filter 60 located between the first chamber 40 and the second chamber 50 to separate out the plasma portion 16 and draw the plasma portion 16 into the second chamber 50; 6) Next, the clinician separates the cap 32 of the device 10 from the tubular member 34 by unscrewing the tubular member 34 and actuator member/plunger rod 70 therefrom; and 7) Finally, the cap 32 is used by the clinician to dispense the plasma into a point-of-care testing device 22 by aligning the dispensing valve 80 with a port or well 24 of the point-of-care testing device 22 and pushing the cap portion 32 in a distal direction one or more times to cause the valve to open up and dispense the plasma portion 16 through the second chamber outlet 54 into the testing device 22.

[0048] Some of the advantages of the blood collection device and the blood separation and testing system of the present disclosure over prior systems are that it is a closed system which reduces blood sample exposure, it provides passive and fast mixing of the blood sample with a sample stabilizer, it facilitates separation of the blood sample without transferring the blood sample to a separate device, and it is capable of transferring pure plasma to a point-of-care testing device. The blood collection device of the present disclosure enables integrated blood collection and plasma creation in a closed system without centrifugation. The clinician may collect and separate the blood sample and then immediately transfer the plasma portion to the point-of-care testing device without further manipulation. This enables collection and transfer of plasma to the point-of-care testing device without exposure to blood. In addition, the blood collection device of the present disclosure minimizes process time by processing the blood within the blood collection device and without external machinery. Further, for tests which only require small amounts of blood, it eliminates the waste associated with blood collection and plasma separation with an evacuated tube.

[0049] While this disclosure has been described as having exemplary designs, the present disclosure can be further modified within the spirit and scope of this disclosure. This application is therefore intended to cover any variations, uses, or adaptations of the disclosure using its general principles. Further, this application is intended to cover such departures from the present disclosure as come within known or customary practice in the art to which this disclosure pertains and which fall within the limits of the appended claims.

CLAIMS:

1. A biological fluid collection device adapted to receive a multi-component blood sample, the biological fluid collection device comprising:

a housing defining a first chamber having a first chamber inlet and a first chamber outlet, a second chamber having a second chamber inlet, and including a separation member disposed between the first chamber outlet and the second chamber inlet, wherein the first chamber outlet is in communication with the second chamber inlet via the separation member, wherein the first chamber is adapted to receive the multi-component blood sample;

an actuator member associated with the second chamber, wherein actuation of the actuator member in a first direction draws a component of the multi-component blood sample from the first chamber through the separation member to the second chamber, and

a valve engaged with the second chamber to seal the second chamber, wherein the valve is transitionable between a closed position in which the second chamber is fully sealed and an open position in which the second chamber is open.

2. The biological fluid collection device of claim 1, wherein the separation member is adapted to allow the component to pass through the separation member to the second chamber.

3. The biological fluid collection device of claim 2, wherein the component is a plasma component.

4. The biological fluid collection device of claim 1, further comprising a septum engaged with the housing to seal the first chamber inlet of the first chamber.

5. The biological fluid collection device of claim 1, wherein the valve is engageable with a receiving port of a testing device for closed transfer of at least a portion of the component from the second chamber to the testing device.

6. The biological fluid collection device of claim 5, wherein the component is a plasma component.

7. The biological fluid collection device of claim 5, wherein the valve transitions from the closed position to the open position via engagement with the receiving port of the testing device.

8. The biological fluid collection device of claim 5, wherein the testing device comprises a point-of-care testing device.

9. The biological fluid collection device of claim 1, wherein the valve is a spring-loaded dispensing valve.

10. The biological fluid collection device of claim 1, wherein the housing includes a tubular member removably engaged therewith.

11. The biological fluid collection device of claim 10, wherein the actuator member is disposable at least partially within the tubular member and wherein the actuator member is removably engaged with the housing.

12. The biological fluid collection device of claim 10, wherein the tubular member and the actuator member are removable from the housing after passage of at least a portion of the component from the first chamber into the second chamber.

13. The biological fluid collection device of claim 12, wherein the component is a plasma component.

14. The biological fluid collection device of claim 12, further comprising a valve engaged with the second chamber to seal the second chamber, wherein the valve is transitionable between a closed position in which the second chamber is fully sealed, and an open position in which the second chamber is open, and wherein transition from the closed position to the open position occurs after the tubular member and the actuator member are removed from the housing.

15. The biological fluid collection device of claim 1, wherein the actuator member comprises a plunger.

16. The biological fluid collection device of claim 1, wherein the housing includes a sample stabilizer.

17. A biological fluid sample separation and testing system for a multi-component blood sample, comprising:

a biological fluid collection and separation device comprising:

a housing defining a first chamber having a first chamber inlet and a first chamber outlet, a second chamber having a second chamber inlet, and including a separation member disposed between the first chamber outlet and the second chamber inlet, wherein the first chamber is adapted to receive the multi-component blood sample; and

a valve engaged with the second chamber to seal the second chamber, wherein the valve is transitionable between a closed position in which the second chamber is fully sealed, and an open position in which the second chamber is open; and

a testing device having a receiving port adapted to engage the valve of the biological fluid collection and separation device, wherein the valve transitions from the closed position to the open position when the receiving port is engaged with the valve.

18. The biological fluid sample separation and testing system of claim 17, wherein the housing includes a tubular member removably engaged therewith and transition of the valve from the closed position to the open position occurs after the tubular member is removed from the housing.

19. The biological fluid sample separation and testing system of claim 17, wherein the separation member is adapted allow a component of the multi-component blood sample to pass through the separation member to the second chamber.

20. The biological fluid sample separation and testing system of claim 19, wherein the component is a plasma component.

21. The biological fluid sample separation and testing system of claim 17, further comprising a septum engaged with the housing to seal the first chamber inlet of the first chamber.

22. The biological fluid sample separation and testing system of claim 17, wherein the valve is engageable with the receiving port of the testing device for closed transfer of at least a portion of a component of the multi-component blood sample from the second chamber to the testing device.

23. The biological fluid sample separation and testing system of claim 22, wherein the component is a plasma component.

24. The biological fluid sample separation and testing system of claim 17, wherein the valve is a spring-loaded dispensing valve.

25. The biological fluid sample separation and testing system of claim 17, wherein the housing includes a tubular member which is removable from the housing after passage of at least a portion of a component of the multi-component blood sample from the first chamber into the second chamber.

26. The biological fluid sample separation and testing system of claim 25, wherein the component is a plasma component.

27. The biological fluid sample separation and testing system of claim 17, further comprising an actuator member associated with the housing, wherein actuation of the actuator member in a first direction draws a component of the multi-component blood sample from the first chamber through the separation member to the second chamber.

28. The biological fluid sample separation and testing system of claim 27,
wherein the component is a plasma component.

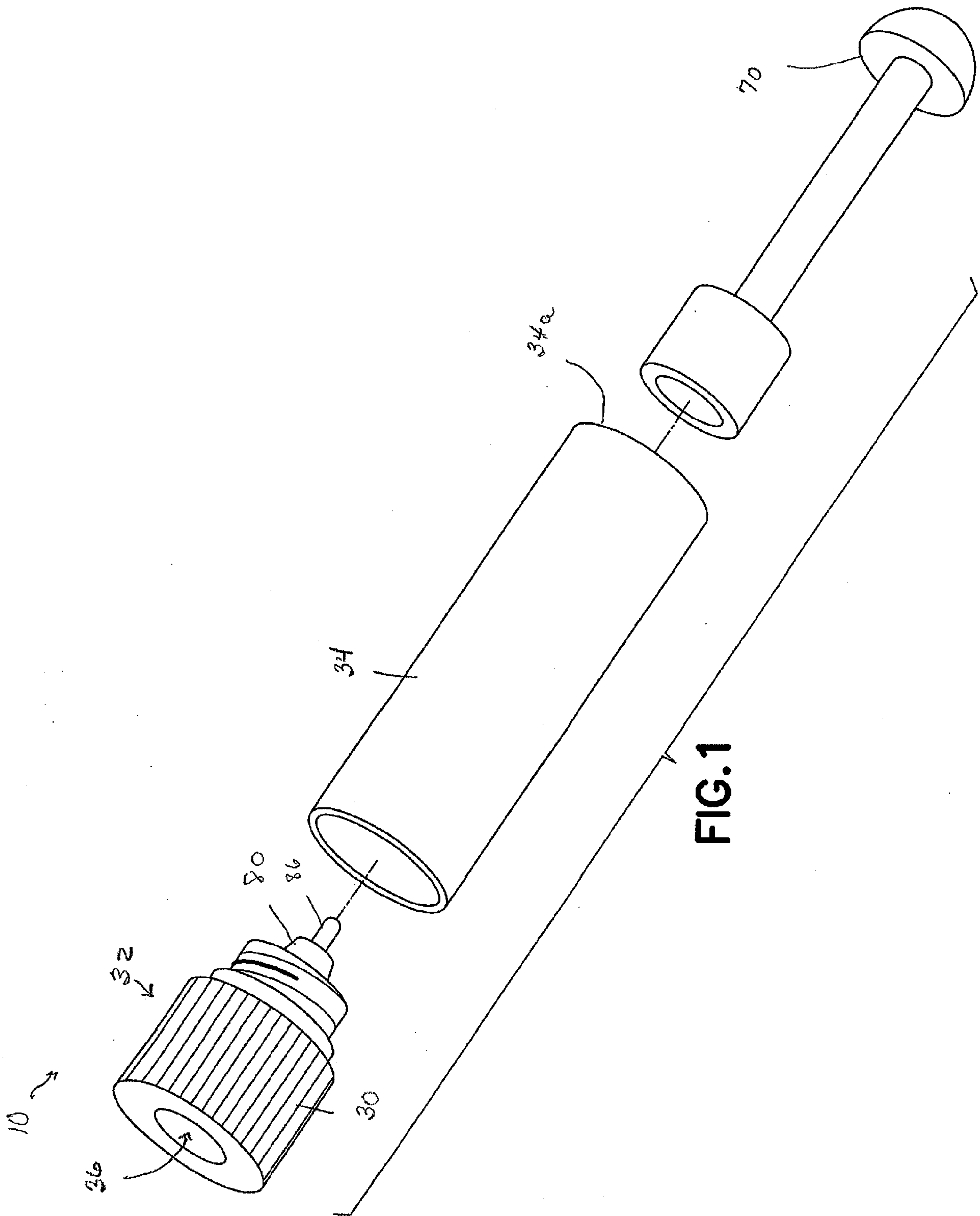

FIG.1

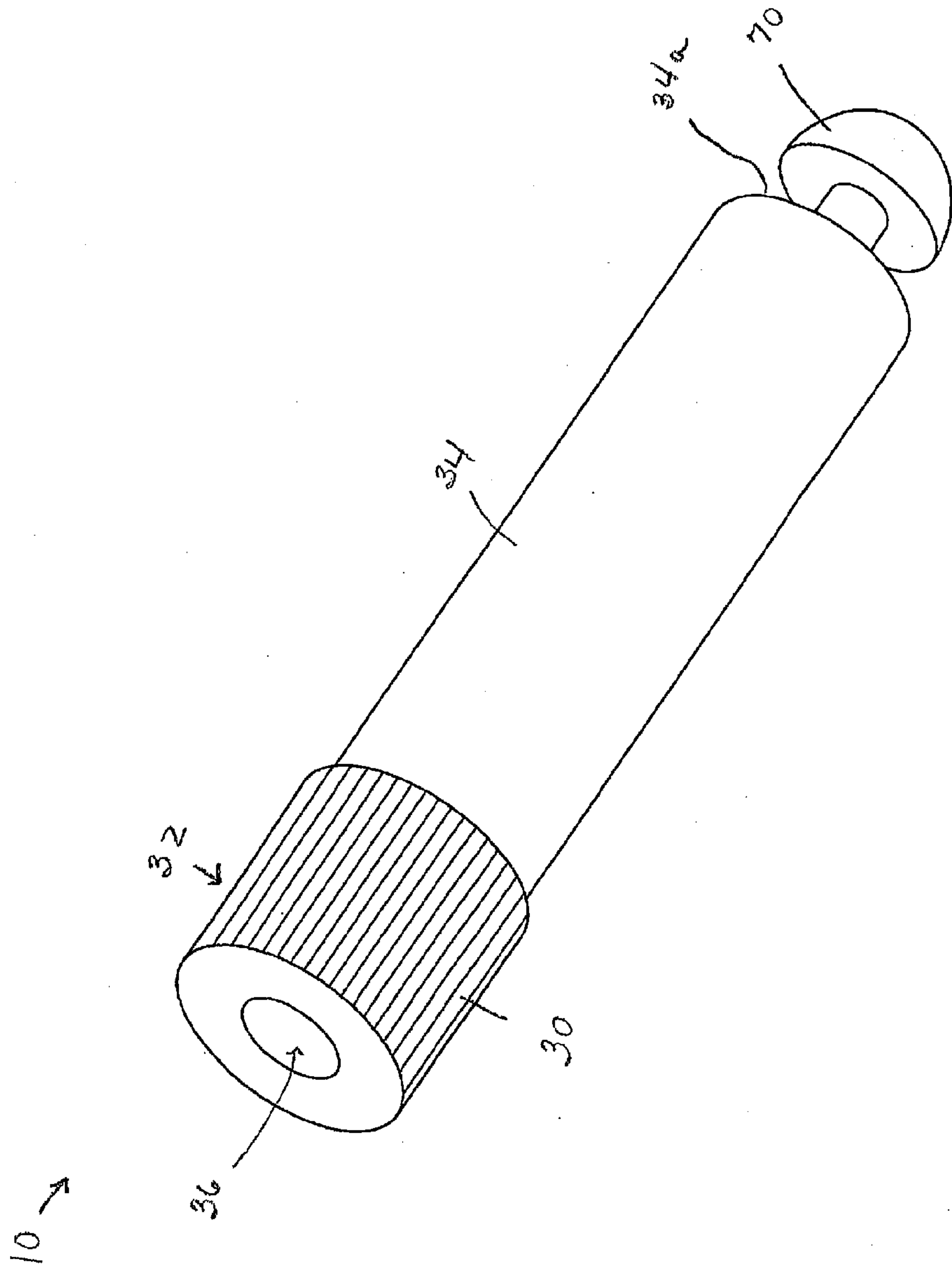

FIG.2

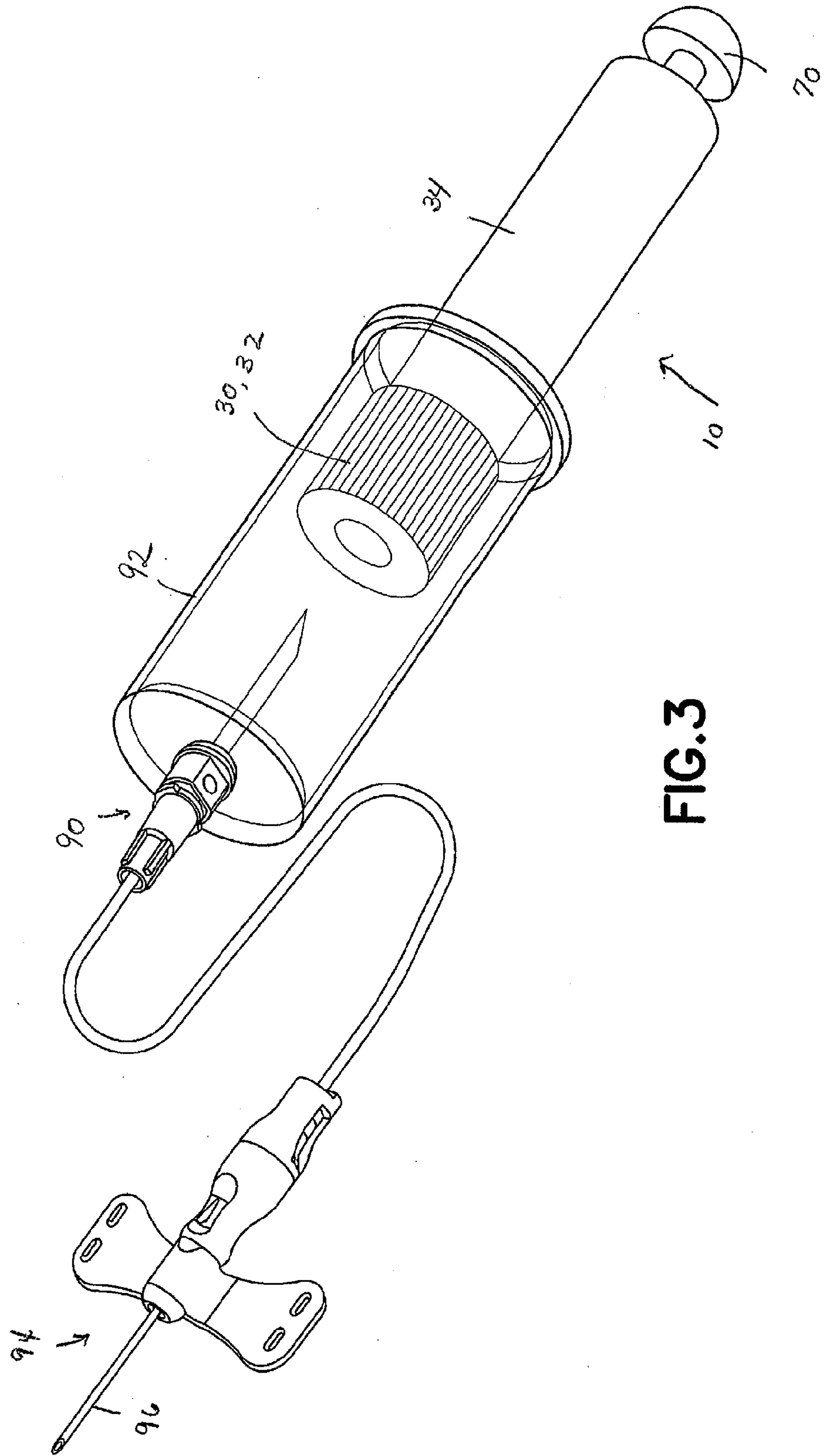

FIG.3

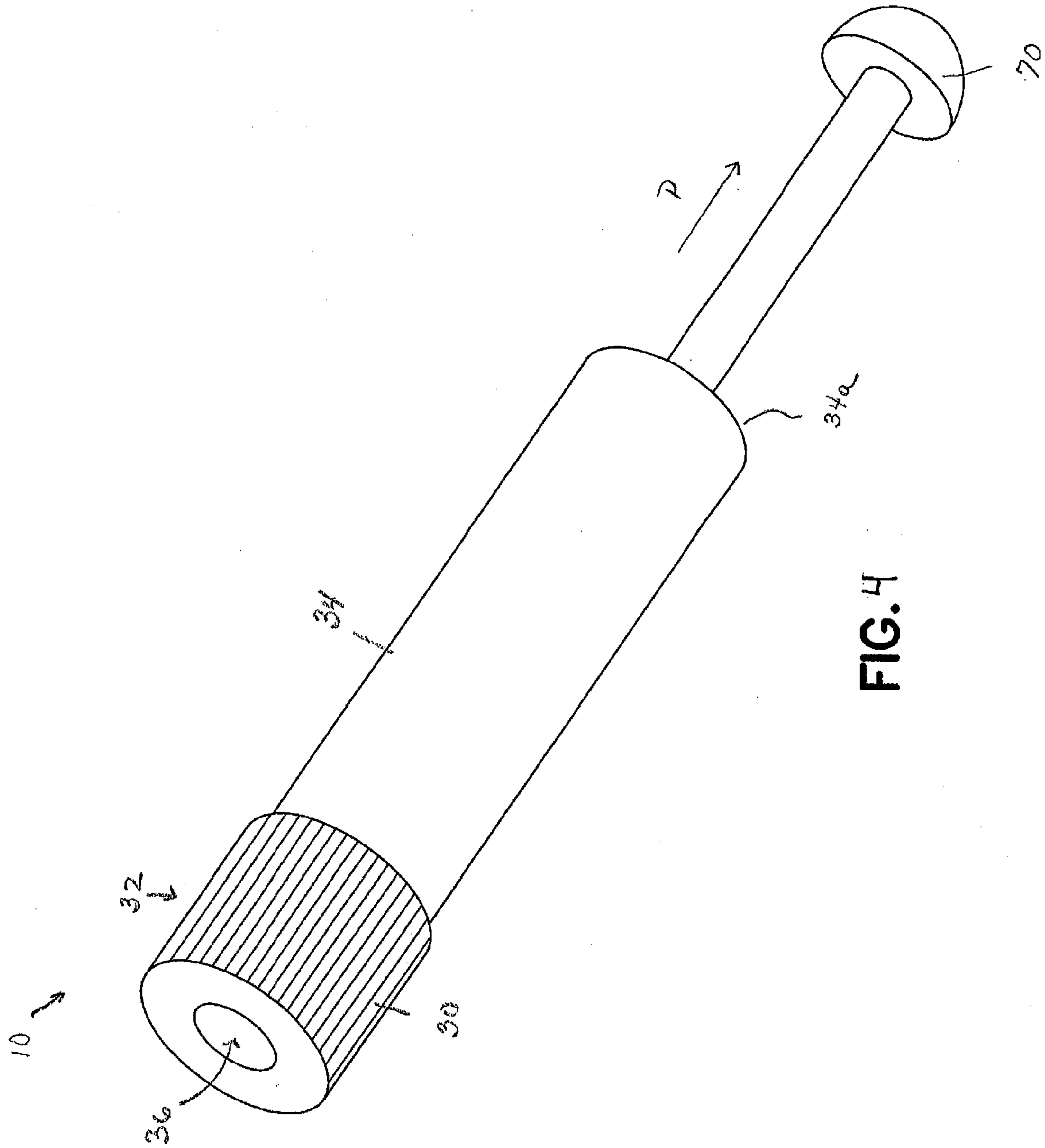

FIG. 4

5/10

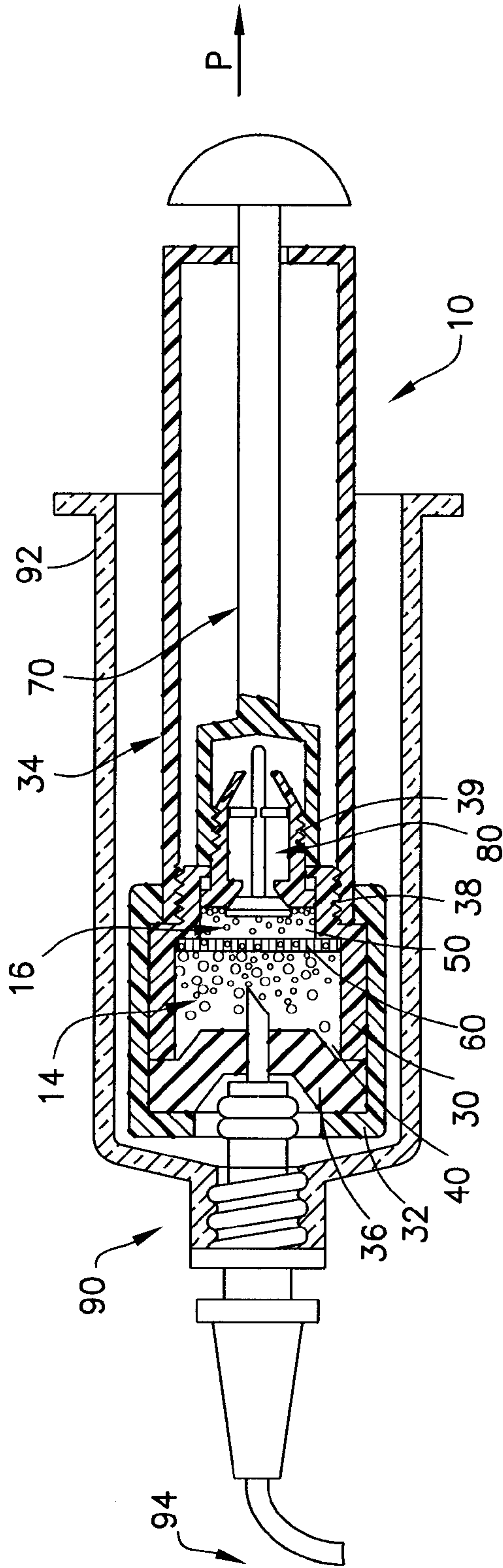

FIG.5

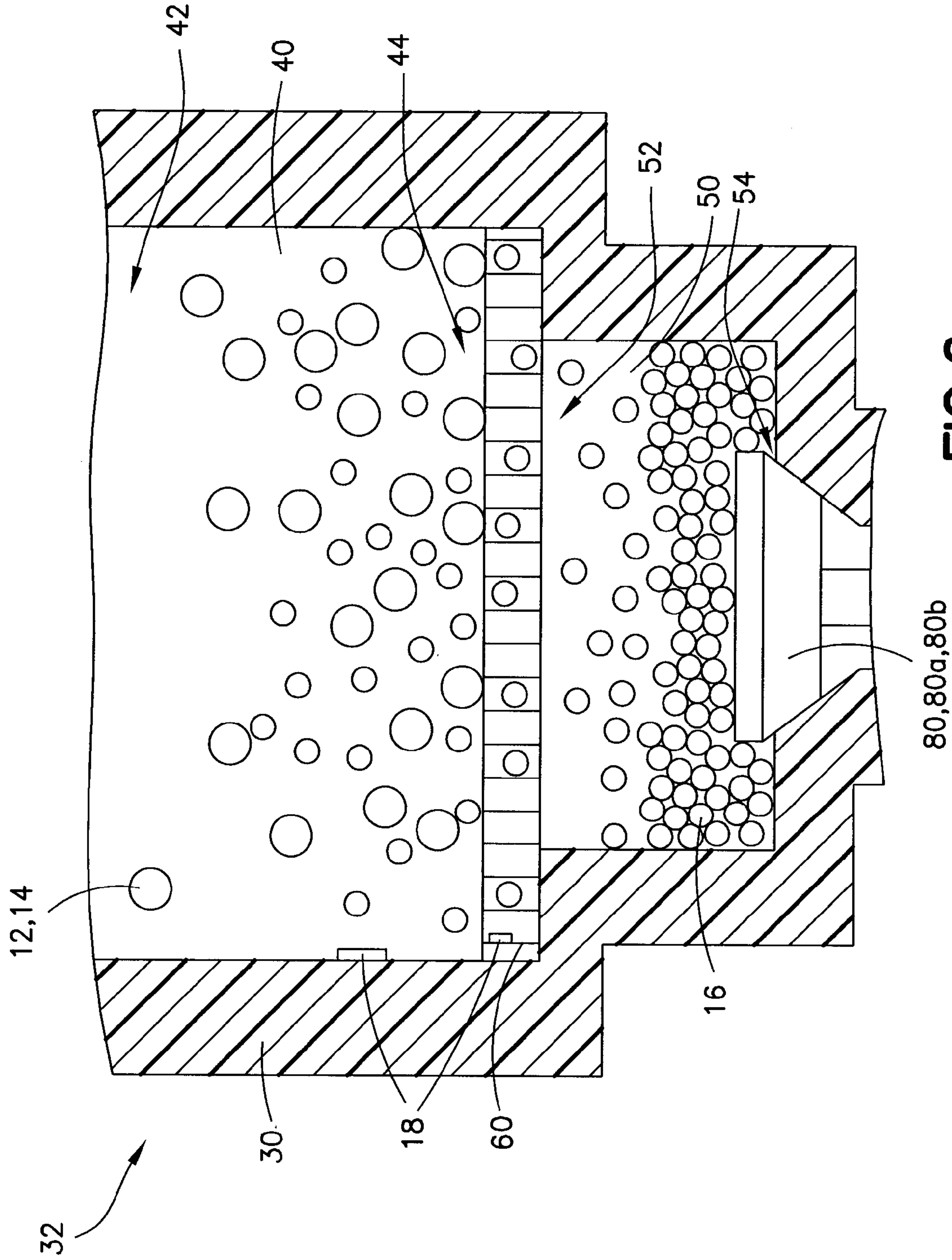

FIG. 6

80,80a,80b

7/10

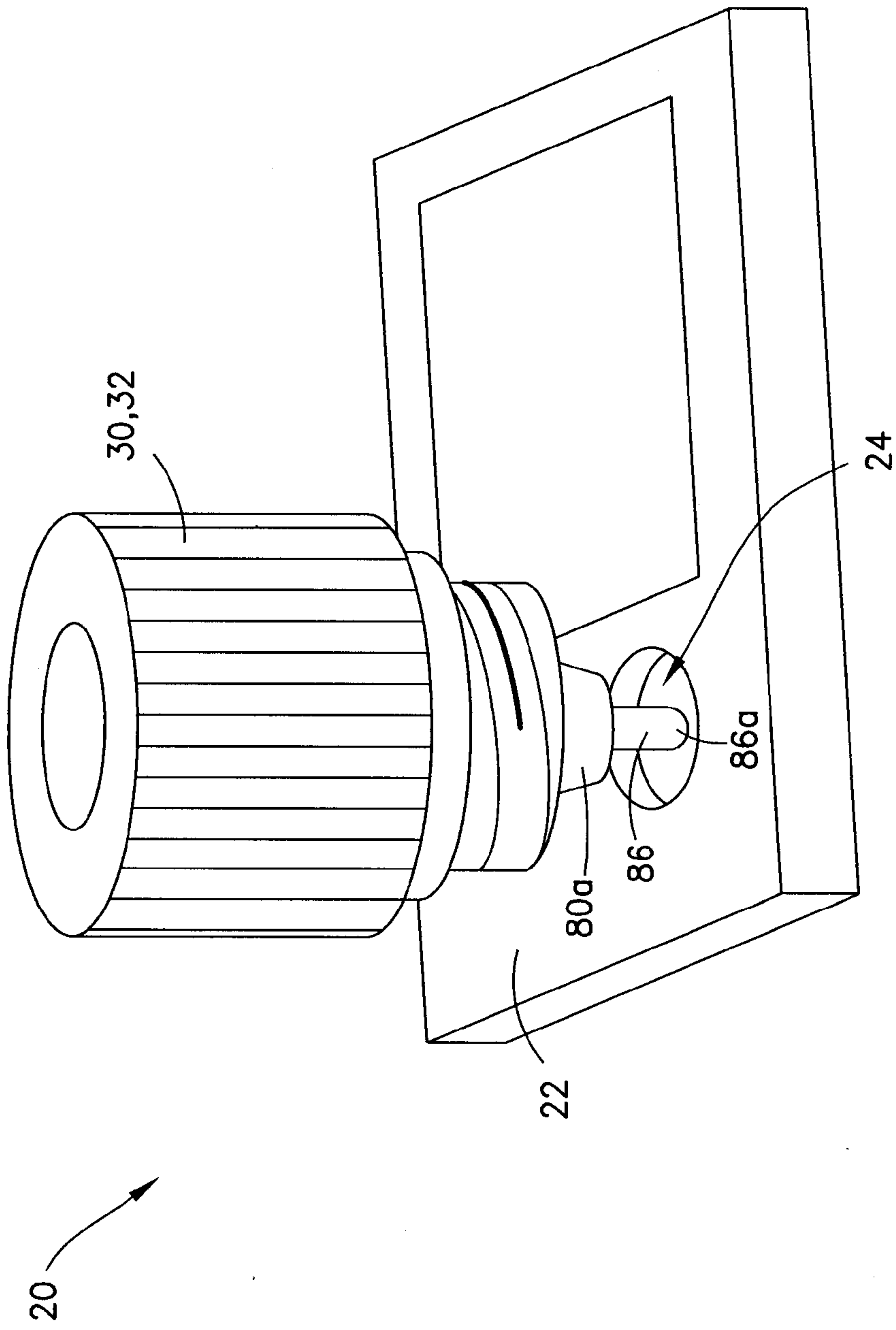
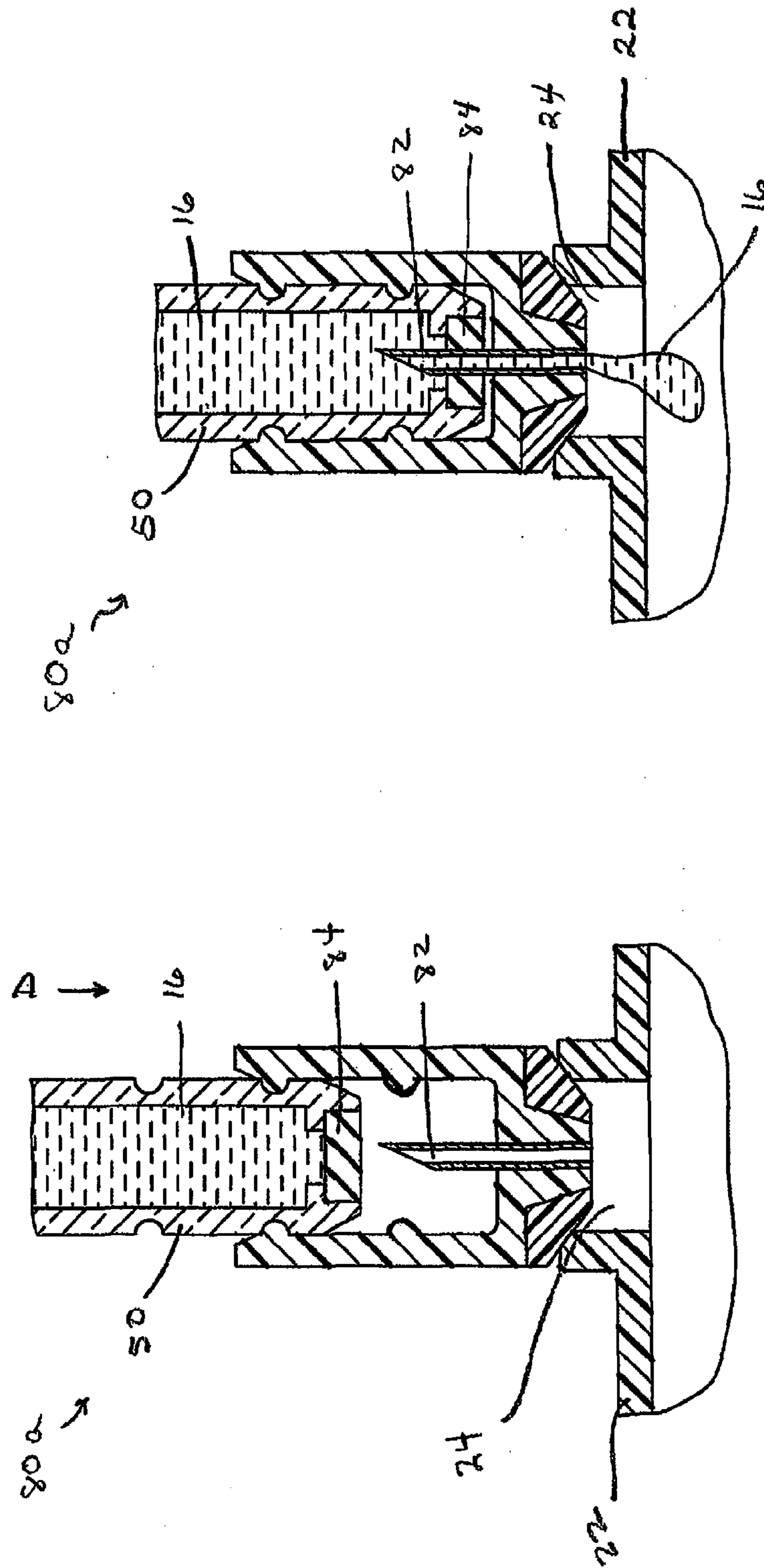

FIG.7



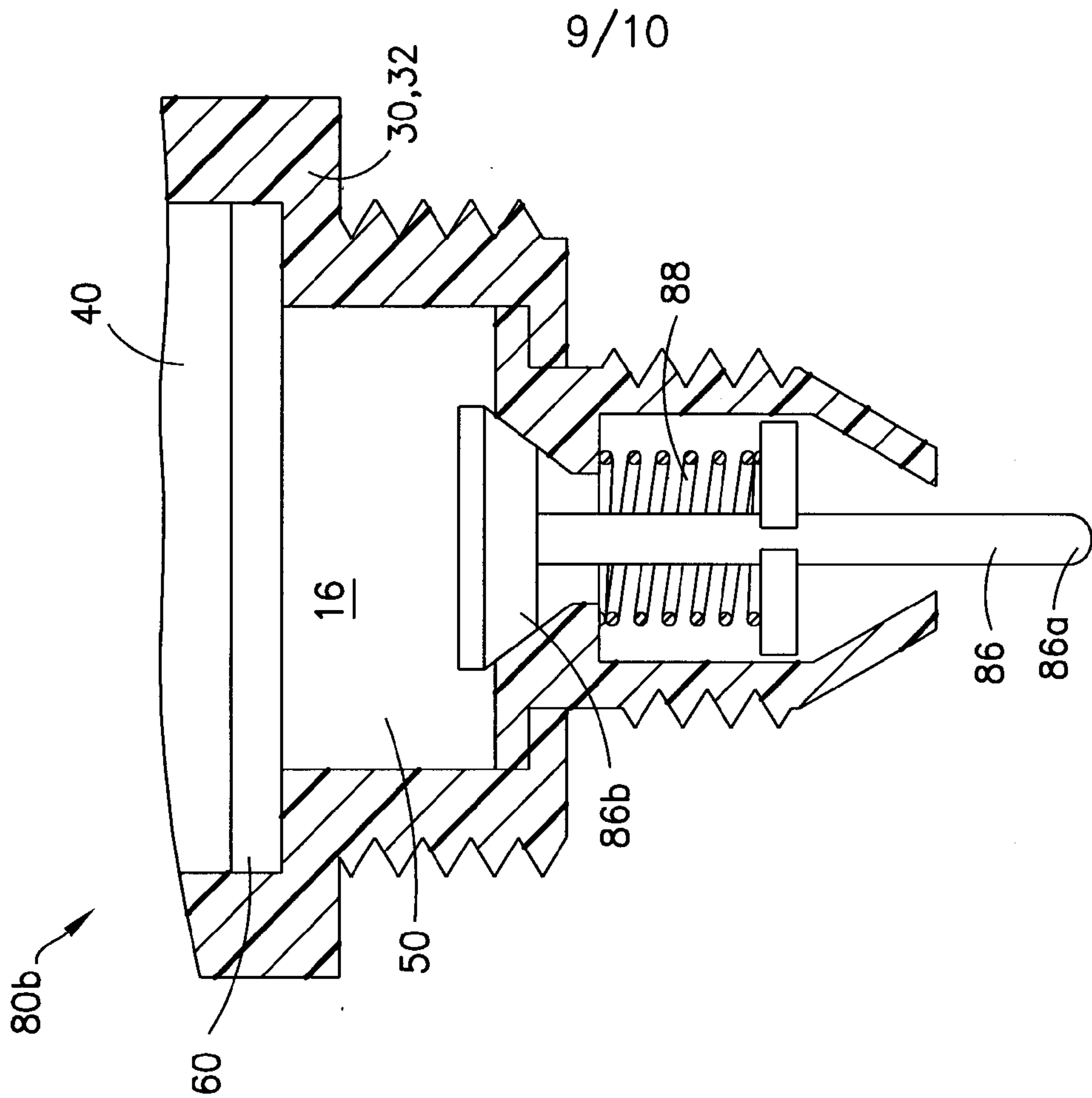

FIG. 10

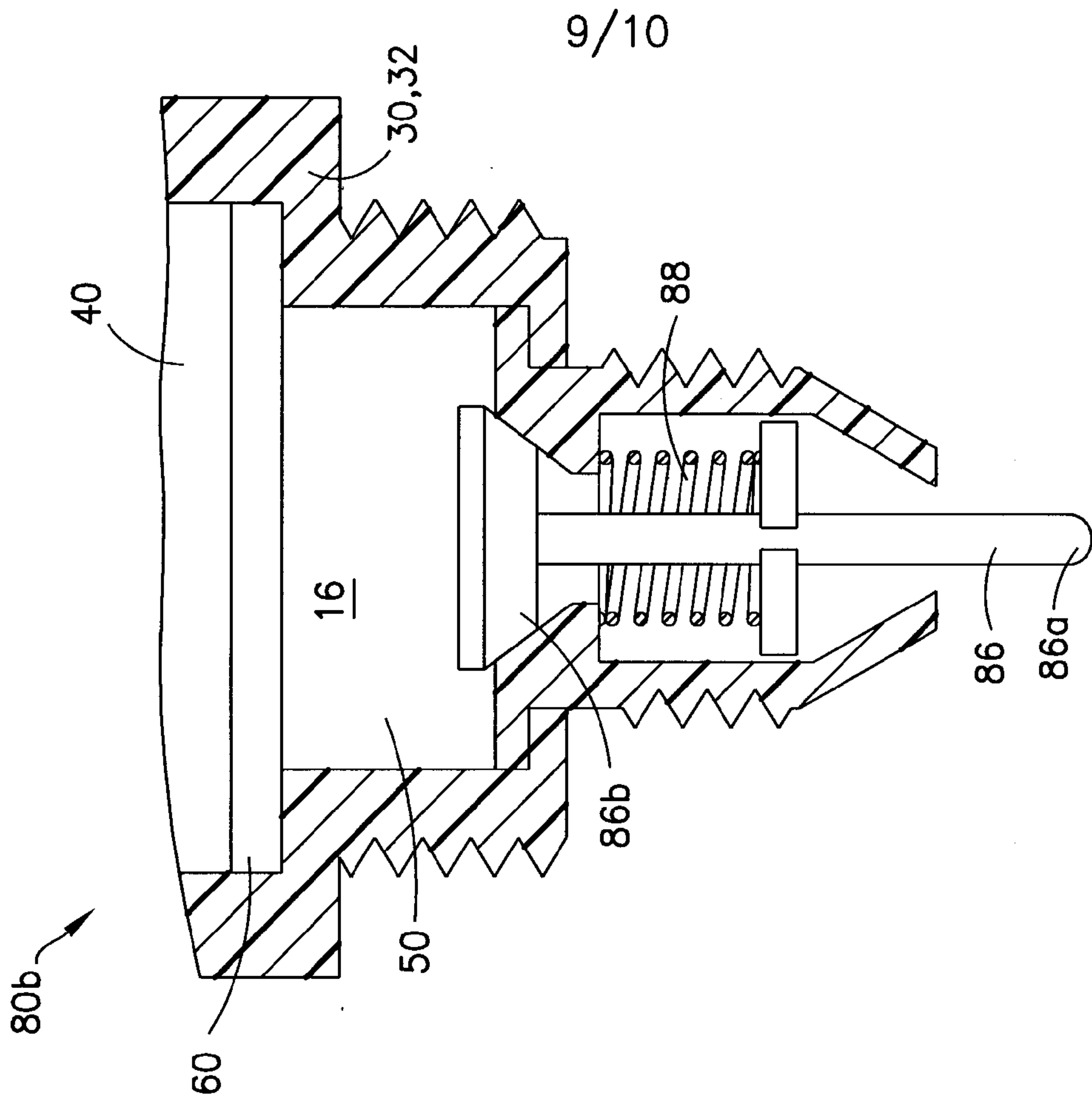

FIG. 11

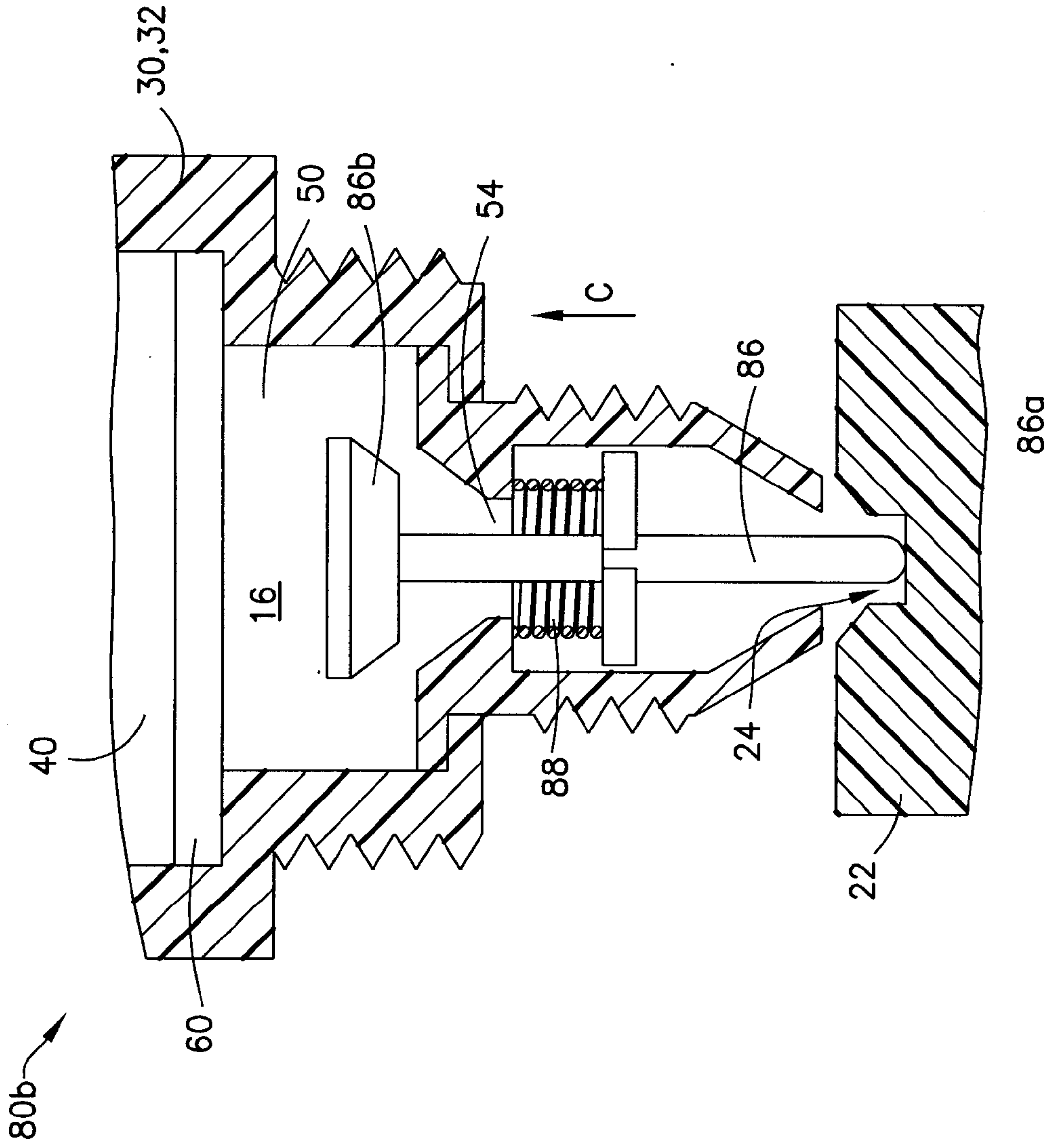

FIG. 12

