



(72) ANDERSEN, ERLING REIDAR, NO

(72) ANDERSEN, ERLING JIM, CA

(71) ANDERSEN, ERLING REIDAR, NO

(71) ANDERSEN, ERLING JIM, CA

(51) Int.Cl.⁷ C01B 3/08, F24J 1/00

(30) 1999/07/28 (2,278,974) CA

(54) **PROCEDE DE PRODUCTION D'ENERGIE ET APPAREIL**

(54) **ENERGY PRODUCTION METHOD AND APPARATUS**

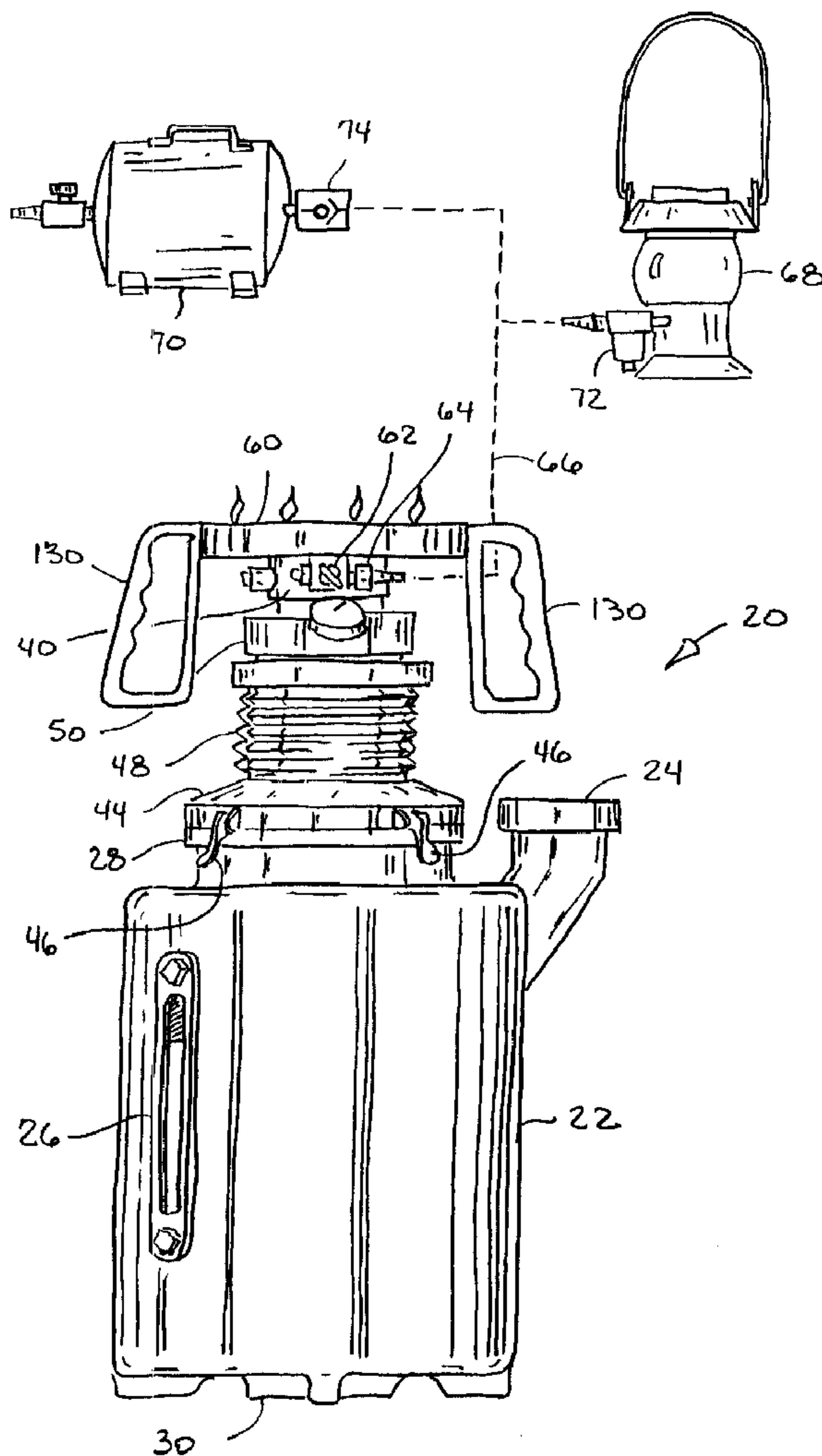

(57) The method for producing hydrogen according to the present invention consists of reacting aluminum with water in the presence of sodium hydroxide as a catalyst. The apparatus for carrying out the method uses the pressure and temperature of the reaction to control the degree of immersion of a fuel cartridge in water and consequently to control the vigor and duration of the reaction.

TITLE: ENERGY PRODUCTION METHOD AND APPARATUS

ABSTRACT OF THE DISCLOSURE

The method for producing hydrogen according to the present invention consists of reacting aluminum with water in the presence of sodium hydroxide as a catalyst. The apparatus for carrying out the method uses the pressure and temperature of the reaction to control the degree of immersion of a fuel cartridge in water and consequently to control the vigor and duration of the reaction.

TITLE: ENERGY PRODUCTION METHOD AND APPARATUS**FIELD OF THE INVENTION**

This invention relates to the production of hydrogen and heat by chemical reaction, and to an apparatus for carrying out the method.

BACKGROUND OF THE INVENTION

It is generally well known in the chemical field that aluminum reacts with water to spontaneously generate hydrogen and heat. It is also known that the reaction between aluminum and water is not sustainable at ambient temperature due to the protective oxide layer forming on the metal surface. Therefore, the use of aluminum as a fuel to generate heat and hydrogen gas requires that the protective layer be efficiently and continuously removed, and that the reaction be kept at an elevated temperature. A number of hydrogen generators are known to be commercially available for use with fuel cells or as heat sources for thermal engines for examples. These generators are generally complicated and precarious to operate by untrained persons. These hydrogen generators are believed to be designed for use by scientists and other professionals working under laboratory conditions.

Examples of hydrogen production methods and apparatus of the prior art are described in the following documents:

US 3,942,511 issued on Mar. 9, 1976 to Black et al. This document discloses a material for use in diver suits. Magnesium and iron particles are imbedded in the material to react with sea water to produce heat and hydrogen gas for increasing the buoyancy of the diver wearing the suit.

US 3,957,483 issued on May 18, 1976 to M. Suzuki. This patent discloses a magnesium composition for the production of hydrogen. It is taught in this document that the presence of one or more elements selected from the group consisting of sodium chloride (NaCl), potassium chloride (KCl) and various similar metal salts leads to an increase in the quantity of hydrogen gas generated.

US 3,975,913 issued on Aug. 24, 1976 to D.C. Erickson. This document discloses an hydrogen generator using liquid aluminum and water.

US 4,223,661 issued on Sept. 23, 1980 to Sergev et al. This patent discloses the details of a portable heat generating system for divers. The system uses magnesium alloys and seawater which when combined together, produces hydrogen gas and heat energy.

US 4,269,818 issued on May 26, 1981 to M. Suzuki. This patent discloses a method for producing hydrogen gas by immersing a piece of magnesium in saltwater.

US 4,340,580 issued on July 20, 1982 to M. Suzuki. This patent is a continuation of the above patent, wherein the method also comprises the application of a direct or an alternating current voltage between a magnesium electrode and another electrode in an electrolyte solution.

US 4,598,552 issued on July 8, 1986 to K. Weber. This patent describes a heat source in which lithium is reacting with water in a reaction chamber to generate heat and hydrogen gas.

US 4,643,166 issued on Feb. 17, 1987 to H.D. Hubele et al. This patent discloses the structure of a fuel cell for producing heat energy and hydrogen gas. The device has a reaction chamber containing a fuel composition that is reactive with water. The fuel composition includes a main fuel part of magnesium and aluminum in a molar ratio of 1:2, and the second part is composed of lithium hydride, magnesium and aluminum in equal molar ratio.

US 4,670,018 issued on June 2, 1987 to J.H. Cornwell. This document describes a log made of compressed wood waste and paper. The log is coated with aluminum particles. Upon burning, the aluminum particles react with moisture in the log to emit great quantity of heat due to the generation of hydrogen gas.

US 4,730,601 issued on Mar. 15, 1988 to N.D. Hubele et al. This patent describes a method for operating a hydrogen and heat producing reaction. The patent is a division of the above patent by the same inventors.

US 4,752,463 issued on June 21, 1988 to K. Nagira et al. This document discloses a material for producing hydrogen gas. The material comprises an aluminum alloy comprising essentially 5 to 50% tin. The disclosure teaches that the hydrogen-producing material reacts with water even at room temperature and produces hydrogen gas with a purity of 99.4% and above.

US 4,769,044 issued on Sept. 6, 1988 to J.H. Cornwell. This patent is a continuation of the patent mentioned above for a log, by the same inventor. In this document, it is taught that the layer of aluminum particles is covered by a layer of paraffin.

US 5,143,047 issued on Sept. 1, 1992 to W.W. Lee. This document discloses an apparatus and a method for generating steam and hydrogen gas. In this apparatus, an aluminum or aluminum alloy powder is reacting with water to generate hydrogen gas. A heat exchanger is provided to extract useful heat. A filter is also provided to remove unwanted reaction byproducts.

US 5,833,934 issued on Nov. 10, 1998 to O.J. Adlhart. This document discloses an hydrogen gas generator using lithium hydride or calcium hydride and water.

US 5,867,978 issued on Feb. 9, 1999 to M. Klanchar et al. This document discloses another hydrogen gas generator using a charge of fuel selected from the group consisting of lithium and alloys of lithium and aluminum. The fuel is molten and mixed with water to generate hydrogen gas.

SUMMARY OF THE INVENTION

The method for producing hydrogen according to the present invention consists of reacting aluminum with water in the presence of sodium hydroxide as a catalyst. The apparatus according to the present invention uses the pressure and temperature of the reaction to control the degree of immersion of a fuel cartridge in water and consequently to control the vigor and duration of the reaction.

The method and apparatus according to the present invention offer a practical process and a safe device for use by the general public to generate heat, light and hydrogen gas in power outage situations or in remote locations where electricity is not available. Furthermore, the method and apparatus according to the present invention use aluminum waste readily available in domestic garbage and metal working shops, to promote recycling and energy conservation.

BRIEF DESCRIPTION OF THE DRAWINGS

A preferred embodiment of the present invention selected by way of examples will now be described with reference to the accompanying drawings, in which:

FIG. 1 is a side view of the preferred energy production apparatus, also referred to herein as the hydrogen generator;

FIG. 2 is a cross-section view of the energy production apparatus illustrating a mode of operation thereof when the fuel cartridge is entirely immersed in water;

FIG. 3 is another cross-section view of the energy production apparatus with the fuel cartridge in a raised position when pressure inside the apparatus force a bellows to expand;

FIG. 4 illustrates yet another cross-section view of the energy production apparatus with the timer mechanism in an unlatched mode causing a spring to pull the cartridge out of the water;

FIG. 5 is a schematic diagram of the preferred gas handling manifold and a burner plate mounted on the energy production apparatus;

FIG. 6 is a side view of the upper fuel support portion of the energy production apparatus;

FIG. 7 illustrates a side view of a preferred burner plate and an optional heat storage device for use with the energy production apparatus;

FIG. 8 is a top view of the preferred timer mechanism for use with the energy production apparatus;

FIG. 9 is a partial cross-section view through the timer mechanism along line 9-9 in **FIG. 8.**;

FIG. 10 illustrates a first arrangement for a fuel cartridge for use with the energy production apparatus;

FIG. 11 illustrates a second arrangement for a fuel unit for use with the energy production apparatus;

FIG. 12 illustrates one form for the catalyst pellet for use with the energy production apparatus;

FIG. 13 illustrates a third arrangement for a fuel unit for use with the energy production apparatus.

FIG. 14 illustrates a graph of temperature over time for a typical hydrogen gas production reaction.

DETAILED DESCRIPTION OF THE PREFERRED EMBODIMENT

While this invention is susceptible of embodiments in many different forms, there is shown in the drawings and will be described in details herein a specific embodiment of the method and apparatus according to the present invention, with the understanding that the present disclosure is to be considered as an example of the principles of the invention and is not intended to limit the invention to the embodiment illustrated.

The production of hydrogen according to the present invention is obtained by a catalytic reaction of aluminum with water. The reaction produces a large amount of heat and hydrogen gas.

The preferred catalyst is sodium hydroxide (NaOH) in various forms. The catalyst is available under its generic name from pharmacies; as lye, a compound for making soap; as caustic soda; or as DranoTM, a well known drain cleaner. The catalyst is mixed with tap water in a proportion of 225 g. per liter of water. In other words, the sodium hydroxide content of the catalytic solution is preferably about 18% by weight. The catalyst is not chemically consumed in the process.

The aluminum used in the reaction comprises aluminum foil, electrical wire, beverage cans and other similar aluminum waste. The vigor of the reaction depends upon the surface of contact between the aluminum and water. Aluminum foil for example reacts faster than a heavy gauge aluminum wire, and aluminum in a powdered form reacts instantly to produce hydrogen gas.

A series of eight experiments was carried out to measure the volume of hydrogen gas produced in a typical reaction. In these experiments, aluminum foil from Reynolds Aluminum Company of Canada was loosely crumpled and placed in a one litre plastic bottle containing 500 ml of catalytic solution. The bottle was quickly capped with a cover fitted with a tube which led to an inverted volumetric cylinder filled with water. The bottle was immersed in a water bath to prevent overheating.

The volume of water displaced by the gas produced was measured and corrected to a gas volume at standard temperature and pressure (STP). Atmospheric pressure on that day was obtained from a local weather office. The corrected volume of gas produced was compared to the theoretical quantity of hydrogen gas, which would be obtained according to the equation,

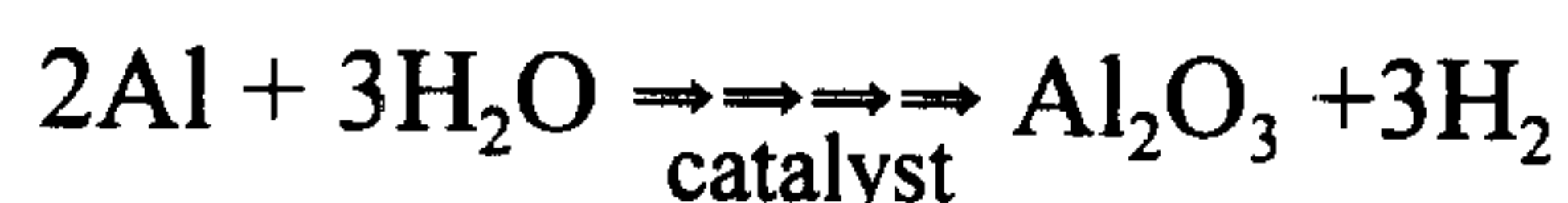

These experiments were carried out at a temperature of 21.0 °C and an atmospheric pressure of 758 mm of Hg. In all cases the reaction started in few seconds and continued for few minutes, until depletion of the aluminum foil. It was noticed that a typical reaction with less than 5 grams of loosely crumpled aluminum foil, is complete in less than 5 minutes. The results of these experiments are shown in **Table 1** below.

Table 1: Hydrogen Gas Production from Aluminum Foil

Exp. (#)	Al (g.)	H ₂ (l)	H ₂ (l) (STP)	H ₂ (l) Theoretical	Yield (%)	Deviation (+/- %)
1	2.08	2.94	2.71	2.59	104	2.6
2	2.03	2.85	2.62	2.53	104	2.6
3	2.21	3.05	2.81	2.75	102	2.5
4	2.16	2.90	2.67	2.69	99	2.6
5	2.20	3.04	2.80	2.74	102	2.5
6	2.21	3.04	2.80	2.76	102	2.5
7	0.73	1.03	0.94	0.91	103	2.4
8	0.83	1.15	1.05	1.03	102	2.2
Ave.					102	2.47

The results from **Table 1** show that the reaction is reproducible and produces stoichiometric quantities of hydrogen gas. The 102% average yield of hydrogen gas is considered to be within the measurement uncertainty; however, there are at least two factors which might have contributed to a slightly higher hydrogen yield. Firstly, the volume of gas produced was corrected to STP. It is possible that the exhausted fume hood in which the experiments were carried out could have lowered the reaction pressure below the atmospheric pressure of 758 mm of Hg. This would have increased the observed value for the volume of gas produced. An exhaust bench typically runs at 1 inch or 2 inches of water pressure. At a maximum, this could have increased the measured volume by about 0.5%. Secondly, the water used was tap water in all cases, in which dissolved air may have been present. If any of this air had been released

in the presence of the warm hydrogen gas, this would have increased the volume of gas measured. This would have affected the results by less than 1%. Since the results are within the measurement error, and quantification of these two sources of error would not significantly affect the results, no further experiment was carried out in this area

The procedure used in the above experiments was repeated, with the exception that the tube leading from the top of the reaction bottle was connected to a gas sampling bag. Two samples of gas were obtained and analysed. The results are presented in **Table 2**.

Table 2: Gas Analysis

Sample	Hydrogen Concentration	Oxygen & Nitrogen
1	92 %	balance
2	98 %	balance

Table 2 shows that the purity of the hydrogen collected in the second sample was 98%. This is close to what was theoretically expected. The lower 92% concentration observed in the first sample was probably due to the fact the system was not completely purged with hydrogen before the sample was taken. By the time the second sample was taken, most of the air had been purged from the tube and the reaction bottle.

The procedure used in the first mentioned experiments was repeated except that the reaction bottle was placed in a water bath before the aluminum was added to the water, and the hydrogen produced was bubbled through the bath water. The temperature of the bath and the catalytic solution were measured before and after the reaction, and at about four minutes after the reaction was completed.

The water equivalent of the plastic containers for absorbing heat and their specific heat were determined experimentally by adding a known quantity of hot water to the reaction system at room temperature and then calculating the heat transfer based on the final temperature.

The quantity of heat produced by the reaction was determined and compared with the theoretical values. The results are shown in **Table 3**.

Table 3: Heat of the Reaction

Readings	Temp. °C Reactor Start	Temp. °C Bath Start	Temp. °C Reactor Finish	Temp. °C Bath Finish	Time
1	21.1	20.2	45.5	24.4	5.29
2	21.1	20.2	38.3	25.3	5.33

Table 3: Continued

Readings	Al (g)	Heats of Formation Al ₂ O ₃ kcal/mole	Heat of Formation H ₂ O kcal/mole	Heat Output Actual kcal	Heat Output Theoretical kcal	Efficiency (%)
1	9.52	- 400.5	- 68.3	33.3	34.5	96
2	9.52	- 400.5	- 68.3	32.5	34.5	94

The results in **Table 3** show that the observed heat released in the production of hydrogen was 96% of the theoretical value. The 94% value from the second reading can be attributed to the heat lost to the surroundings during the time that lapsed between the readings.

The reaction has a net maximum heat production during hydrogen generation of 195.6 kCal/mole. A further 204.9 kCal/mole will be released if the hydrogen is burned with oxygen. Stated another way, 51% of the reaction energy is used to form hydrogen gas and 49% goes into the production of heat.

After analysing these data, it was decided that recovery of the solid residue was unnecessary since it must be alumina (Al_2O_3), or some form of alumina-sodium hydroxide complex. This could be reclaimed and reprocessed into refractory products or recycled into aluminum.

Having explained the preferred method for producing hydrogen gas, the following disclosure and drawings describe a preferred apparatus for carrying out the method.

Referring firstly to **FIGS. 1 and 2**, an energy production apparatus according to the preferred embodiment of the present invention is illustrated therein. The energy production apparatus, also referred to herein as the hydrogen generator **20** is illustrated in these figures in its entirety. The hydrogen generator **20** uses water and aluminum particles as fuel, and sodium hydroxide (NaOH) or caustic soda as a catalyst and a surface conditioner to reduce the formation of oxide layers on the aluminum particles. The caustic soda may be mixed or otherwise closely associated with the aluminum particles in a sufficient amount to ensure complete reaction of the aluminum particles with water in an energy production period. Further discussion on the incorporation of caustic soda with the aluminum particles will be provided later, especially when making reference to **FIGS. 10-13**.

The hydrogen generator **20** comprises firstly a receptacle **22** having a first closable fill opening **24**, a sight glass **26** for monitoring the level of water therein, and a second closable larger opening **28** in a central upper region thereof. The receptacle **22** also preferably has a cleanout bung **30** through its bottom surface to facilitate the periodic removal of the reaction byproducts such as alumina.

In use, the receptacle **22** is filled with water **32**, to a level of between half and three-quarter of its capacity. A fuel cartridge **34** hanging from a vertical tube **36** is immersed into the water **32** for causing a chemical reaction to occur with the water, and for producing heat and hydrogen gas.

The fuel cartridge **34** is supported in a perforated basket **38** affixed to the vertical tube **36**. The vertical tube **36** is connected to a gas handling manifold **40** mounted above the receptacle **22**, and has a series of holes **42** therein for admitting the hydrogen gas into the gas handling manifold **40**.

An annular cap **44** is also provided for mounting over the upper central opening **28** of the receptable. Several clasps **46** are provided around the annular cap **44** for securing the annular cap **44** in a sealing manner to the upper central opening **28**. It will be appreciated that the upper central opening **28** has a dimension to accommodate the insertion of the fuel cartridge **34** and the basket **38** inside the receptacle **22**. It will also be appreciated that the clasps **46** may be replaced by other closure means for quickly and easily removing the annular cap **44**, for replacing a spent fuel cartridge for example.

Upon the annular cap **44**, there is provided a bellows **48** having an interior region communicating with the receptacle **22** such that the expansion and retraction of the bellows are relative to the pressure inside the receptacle. Atop the bellows **48**, there is provided a timer mechanism **50**, the operation of which will be described later. In the hydrogen generator according to the preferred embodiment **20**, the gas handling manifold **40** is affixed to the upper portion of the timer mechanism **50**.

The annular cap **44**, the bellows **48**, the timer mechanism **50** and the gas handling manifold **40** define with the receptacle **22** a closable space for containing and controlling the hydrogen gas being generated inside the receptacle **22**.

The gas handling manifold **40** is preferably mounted under a burner plate **60** and has conduit means communicating with the burner plate **60**. A series of orifices are provided in the burner plate **60** to allow the burning of hydrogen gas for cooking food for example in a similar manner as is known of gas stoves. Although the illustrations show a side view of the burner plate **60** it will be appreciated that the burner plate **60** is preferably a circular plate similar to those mounted on common gas stoves.

The gas handling manifold **40** also has a selector valve **62** and a gas outlet fitting **64** communicating with the selector valve **62**. The selector valve **62** is operable for selectively directing the hydrogen gas to the burner plate **60** or to the outlet fitting **64**.

The outlet fitting **64** is connect-able, by means of a flexible hose for example, as represented by dash lines **66**, to a gas appliance such as a lantern **68** or to a gas reservoir **70** for accumulating the hydrogen gas for

later use. The appliance may have a water filter **72** thereon if needed or a check valve **74** to prevent any backflow of gas into the receptacle **22** at the end of an energy production period.

With reference to **FIGS. 2** and **14**, it will be appreciated that a typical energy production period is known to have a heating phase 'A' during which the temperature inside the receptacle **22** rises; an active phase 'B' during which the temperature inside the receptacle **22** is preferably kept at around 85° C, and a cooling phase 'C' during which the reaction gradually stops. At an operation temperature 'T' during the active phase 'B' of about 85° C, the reaction has been found to be self-sustained and the hydrogen gas produced contained minimum water vapours.

The heating phase 'A' can be shortened by introducing a fuel pellet **80** inside the receptacle **22**, through the fill opening **24**. The fuel pellet **80** preferably contains very fine aluminum particles such as saw dust and filings for examples, compressed with waste paper bits that are impregnated with caustic soda in a dry form. The small aluminum particles of the pellet **80** are known to be highly reactive with water to generate a burst of heat which causes the water temperature to approach the ideal temperature 'T' quickly, and to accelerate a reaction of the water with the larger fuel cartridge **34**. Another fuel pellet **80** may also be introduced in the receptacle during the cooling phase 'C' to prolong the duration of an energy production period.

For example purposes, a fuel cartridge **34** having a volume of about one liter, that is about 500 ml of aluminum and about 500 ml of paper filler material impregnated with caustic soda in a dry form, immersed in 10 liters of water is believed to be sufficient for producing heat and maintaining a

reaction for about two hours, in which the active phase is about one hour, and the heating and cooling phases are about one-half hour each. It is believed that the amount of hydrogen gas produced during the active phase 'B' is sufficient for cooking food on the burner plate 60.

Referring now to FIG. 3, the operation of the bellows 48 is illustrated therein. When the reaction enters its active phase, the heat and pressure generated inside the receptacle 22 rise. The increase in pressure inside the receptacle 22 causes the bellows 48 to expand upward as illustrated in FIG. 3.

Because the basket 38 and the vertical tube 36 are supported to the gas handling manifold 40, and because the gas handling manifold 40 is affixed to the movable portion of the bellows 48, the expansion of the bellows 34 causes the fuel cartridge 34 to be lifted toward an upper region of the receptacle 22, and by the same doing, causes the water level to fall in the receptacle 22. The contact surface between water and the fuel cartridge 34 is thereby greatly reduced. The reaction is slowed down and the pressure and temperature inside the receptacle 22 are consequently also reduced. As temperature and pressure inside the receptacle 22 are reduced, the bellows 48 collapses to re-immerses the fuel cartridge 34 and to resume the active reaction phase.

Given the structure of the energy production apparatus 20 according to the preferred embodiment, it is believed possible to calibrate the characteristics of the bellows 48 for use with a specific size of receptacle 22 and a specific size of fuel cartridge 34, to precisely control the pressure and temperature of a reaction, such that the apparatus 20 will be practical and safe for use by the general public.

With reference to **FIGS. 4, 8 and 9**, the functions of the timer mechanism **50** of the hydrogen generator **20** will be explained in details. The timer mechanism **50** is provided for further improving the safety of the hydrogen generator **20**. The timer mechanism **50** is used for lifting the fuel cartridge **34** above the water **32** after a set time period, even when the bellows **48** remains in a collapsed mode. The reaction inside the receptacle **22** can thereby be manually stopped or caused to terminate at a set time period by adjusting a knob **90** relative to a dial **92**.

The preferred timer mechanism **50** comprises a coil spring **94** mounted over the vertical tube **36** and an annular spring-abutment plate **96** affixed to the vertical tube **36** above the spring **94** for retaining the vertical tube **36** at a fixed position relative to the upper end of the spring **94**.

The spring **94** is set in a cylindrical pocket **98** extending downward through the timer mechanism **50**. The depth of the pocket **98** is sufficient to accommodate the spring **94** in a compressed form when the timer mechanism is in a latched mode. A seal **100** is affixed to the bottom portion of the pocket **98** around the vertical tube **36**, for allowing a sliding movement of the vertical tube **36** through the timer mechanism **50**, under the action of the spring **94**, and for preventing hydrogen gas from leaking out of the bellows **48**.

One or more latch tabs **102** are movably connected to the timer mechanism **50** and are linked to the operation of the selector knob **90**. When the burner plate **60** is pushed down to immerse the fuel cartridge **34** in water, the latch tabs **102** engage with the annular spring-abutment plate **96** to keep the spring **94** in a compressed state inside the cylindrical pocket **98**.

The linkages, the clockwork and other components mounted inside the timer mechanism **50** have not been illustrated herein for being common to those knowledgeable in latches and locks. In the preferred embodiment, however, the clockwork is a mechanical device not requiring electric power. Also, in the preferred embodiment the latched tabs **102** are in a latching position when the timer knob **90** is set at any time value, and are in an unlatching position when the knob **90** is set at or reaches zero (0) time on the dial **92**.

Referring now to **FIG. 5**, the structure of the burner plate **60** and of the gas handling manifold **40** are explained therein in greater details. The outline of the gas handling manifold **40** is shown in dash lines to simplify the illustration. The gas handling manifold **40** comprises a first set of conduits **110** extending from the vertical tube **36** to the selector valve **62**, to a pressure relief valve **112**, and to a flow control valve **114**; a second set of conduits **116** extending from the selector valve **62** to the burner plate **60**; and a third conduit **118** extending from the selector valve **62** to the outlet fitting **64**.

The burner plate **60** has a plurality of gas orifices **120** therein, and each gas orifice is preferably surrounded by one or more air injection holes **122** to admit oxygen around the gas orifice **120** during the burning of hydrogen gas.

In the preferred embodiment, a minimum amount of hydrogen gas is always directed to the gas orifices **120** to be burnt. The burning of this minimum amount of gas provides a visual indication of the operation of the apparatus **20**, and prevents any accumulation of hydrogen gas in the

room in which the apparatus is being used. For this purpose, a flow control valve 114 is provided in the gas handling manifold 40, and has a fourth conduit 124 bypassing the selector valve 62. Therefore, when the selector valve 62 is set to direct the hydrogen gas to the outlet fitting 64, a minimum amount of gas is still allowed through the flow control valve 114 and to the gas orifices 120 of the burner plate 60.

The flow control valve 114 is preferably an adjustable type such that it can be opened fully to bypass both the selector valve 62 and the pressure relief valve 112, to obtain a larger flame 126 at the center of the burner plate 60 if needed.

The pressure relief valve 112 is provided to further improve the safety of the apparatus, as will be understood from the following description. The pressure relief valve 112 monitors the pressure inside the vertical tube 36 and releases a pressure over an unsafe level, to a whistle 128 which has an outlet opening positioned near one of the gas orifices 120. The gas flowing from the whistle 128 may thereby be readily ignited by the flame above that orifice 120, to provide a visual indication of an abnormal operation of the apparatus. The sound of the whistle 128 is yet another sign to alert a user of an over pressure inside the receptacle 22, and to urge that user to set the knob 90 to zero time to cause the timer mechanism 50 to raise the fuel cartridge 34 out of the water.

As illustrated in FIG. 6, the burner plate 60 preferably has a pair of handles 130 affixed thereto to manipulate the upper portion of the apparatus 20 when the clasps 46 are released and the basket 38 is lifted out of the receptacle 22.

In the preferred apparatus, a gas filter **132** may also be installed over the gas admitting holes **42**, for preventing any accumulation of reaction byproducts inside the vertical tube **36**. In other embodiments, the vertical tube **36** may be filled with an appropriate granular filtering media for example for preventing reaction byproducts from reaching the gas handling manifold **40**.

As will be appreciated, a pressure gauge **134**, a temperature gauge or both, may also be provided on the annular cap **44** or at another convenient location allowing a communication with the receptacle **22**, for visually monitoring the development of a reaction occurring inside the apparatus.

In **FIG. 7**, the burner plate **60** is shown supporting a heat storage device **140**, for storing heat during the operation of the apparatus **20**. The heat storage device **140** is used for prolonging the beneficial effect of an energy production period when the apparatus **20** is used to heat a camp in the wilderness, or a household during a power outage period for example. The preferred heat storage device **140** comprises a copper plate **142**, supported on legs **144**, above the burner plate **60**, and a perforated dome-shape enclosure **146** enclosing one or more rocks **148** laid over the upper portion of the copper plate **142**. The heat storage device **140** is removable from the burner plate **60** and is preferably used whenever the burner plate **60** is not used for cooking food. Further, the receptacle **22** is preferably made of steel or similar heat conductive material for radiating heat during the entire energy production period.

In the preferred embodiment, the inside diameter of the bellows **48** is sufficiently large, 15-25 cm for example, and the spring **94** is calibrated such that the weight of the heat storage device **140** or the weight of a common cooking pot (not shown) which may be set on the burner plate **60** does not significantly affect the operation of the bellows **48** or of the timer mechanism **50**.

Referring now to **FIGS. 10-13**, several arrangements are proposed for preparing the fuel elements required for use in the hydrogen generator **20** according to the preferred embodiment. The fuel bundle **34** is preferably prepared by superimposing a thin strip of aluminum **150** over a sheet of embossed paper **152** impregnated with caustic soda in a dry form. The aluminum sheet and the paper layer are coiled together to form a cylindrical shape. The preferred cartridge **34** is loosely coiled such that water may be readily absorbed between the layers of the cartridge. The advantage of a loosely coiled cartridge **34** is that the water is allowed to seep into the entire cartridge at once to create a vigorous reaction, and reduce the duration of the heating phase 'A' illustrated in **FIG. 14**.

Another advantage of the cartridge **34** as described above is that when the layers of the coil are set vertically, the hydrogen gas generated between the layers rises up and creates a vacuum between the layers at the lower end of the cartridge **34** to admit more water from the lower end of the cartridge. This phenomenon is advantageous for wetting the aluminum strip quickly, entirely and continuously.

The preferred fuel cartridge **34** is packaged in a sealed envelope that has an indication as to its duration, potential heat energy and volume of hydrogen gas to be produced by it.

Although the fuel cartridge **34** may be better manufactured with virgin material, it will be appreciated that there are numerous economical and environmental advantages in the manufacturing of fuel elements from waste materials. Accordingly, another preferred fuel unit **160** having a loose content in a bag-like envelope is illustrated in **FIG. 11**. The envelope **162** is water-permeable, and the loose content comprises aluminum turning, aluminum saw dust and filings, aluminum shreds and other aluminum waste particles **164** as normally found in a metal working shop, or as available from scrap metal vendors.

It is also possible to use aluminum shreds from domestic waste containers. When the waste aluminum is obtained by shredding food or drink containers for example, the waste material is preferably pre-treated to at least partly remove a protective coating on this aluminum material.

The loose content of the fuel unit **160** also comprises waste paper bits **166** impregnated with caustic soda and dried. The paper bits **166** are made of waste newsprint or similar recyclable paper waste. The paper bits **166** preferably have sizes and quantities similar to the aluminum particles, and are mixed with the aluminum particles **164**. The presence of the paper bits **166** prevents the fusion of the aluminum particles **164** together and ensures a continuous absorption of water throughout the loose content of the fuel unit **160**. The fuel unit **160** is also preferably manufactured and labelled as to indicate its expected energy production period.

The fuel pellet **80** as illustrated in **FIGS. 2** and **12**, and as previously described contains very fine aluminum particles such as saw dust and filings for example, to provide a better water contact and a more vigorous reaction. One or two fuel pellets **80** are preferably packaged in a sealed envelope and distributed as reaction accelerators with each fuel cartridge **34**, or with each fuel unit **160** sold.

A third preferred arrangement for a fuel element usable in the apparatus **20** according to the preferred embodiment is illustrated in **FIG. 13**. The fuel measure **170** is preferably comprised of a perforated container **172** filled with aluminum waste **164** and paper bits **166** as previously described.

When the energy production apparatus according to the preferred embodiment **20** is used by a user having access to aluminum waste material, and who does not want to depend on purchased fuel elements, the fuel measure **170** described herein is recommended and is preferably used with a nominal quantity of caustic soda **174** set over the fuel measure **170**. The caustic soda **174** may be compressed into a tablet form **174** as illustrated for easy handling and storage. It may be used in a powder form contained in a water-permeable sachet (not shown), or may be kept in a sealed container and sprinkled generously over the water **32** before introducing the fuel measure **170** into the water **32**.

As to the manner of manufacture of the preferred apparatus, the same should be apparent from the above description and accompanying drawings, and accordingly further discussion relative to this aspect would be considered repetitious and is not provided.

While one embodiment of a method and of one apparatus have been described herein above, it will be appreciated by those skilled in the art that various modifications, alternate materials, compositions and equivalents may be employed without departing from the true spirit and scope of the invention. Therefore, the above description and illustrations should not be construed as limiting the scope of the invention which is defined by the appended claims.

CLAIMS

We claim:

1. A method for producing hydrogen gas, comprising the steps of:
providing a solution of water and sodium hydroxide, and
immersing aluminum material in said solution;
such that a volume of hydrogen gas produced thereby is relatively
pure and stoichiometrically reliable.
2. An energy production method for producing heat, light and
hydrogen gas, comprising the steps of:
providing an expandable receptacle;
partly filling said expandable receptacle with water;
introducing in said expandable receptacle an aluminum element and
caustic soda;
partly sealing said expandable receptacle;
immersing said aluminum element and said caustic soda in said
water; and
expanding and retracting said expandable receptacle and raising
and lowering said aluminum element relative to said water,
in response to more or less pressure inside said expandable
receptacle respectively;
such that a chemical reaction between said water and said
aluminum element is controllable in response to a pressure
generated inside said expandable receptacle by said chemical
reaction.

3. An energy production apparatus for producing heat, light and hydrogen gas, comprising;
- an expandable receptacle having an upper end, a central portion, a bellows mounted to said upper end and a sealing means connected to said bellows for partly sealing said receptacle; said bellows having a fixed portion connected to said upper end of said expandable receptacle and a movable portion movable toward and away from said upper end of said expandable receptacle;
- a fuel basket mounted inside said expandable receptacle in said central portion of said expandable receptacle, said fuel basket being connected to said movable portion of said bellows; and
- said expandable receptacle being adapted to contain water in said central portion thereof, and said fuel basket being adapted to contain an aluminum element;
- such that said fuel basket is movable toward and away from said central portion of said expandable receptacle for immersing and lifting an aluminum element in and out of water respectively, to control a chemical reaction between said aluminum element and said water.

Mario D. Theriault, P.Eng.

“Patent Agent of the Applicants”

INFORMAL DRAWING

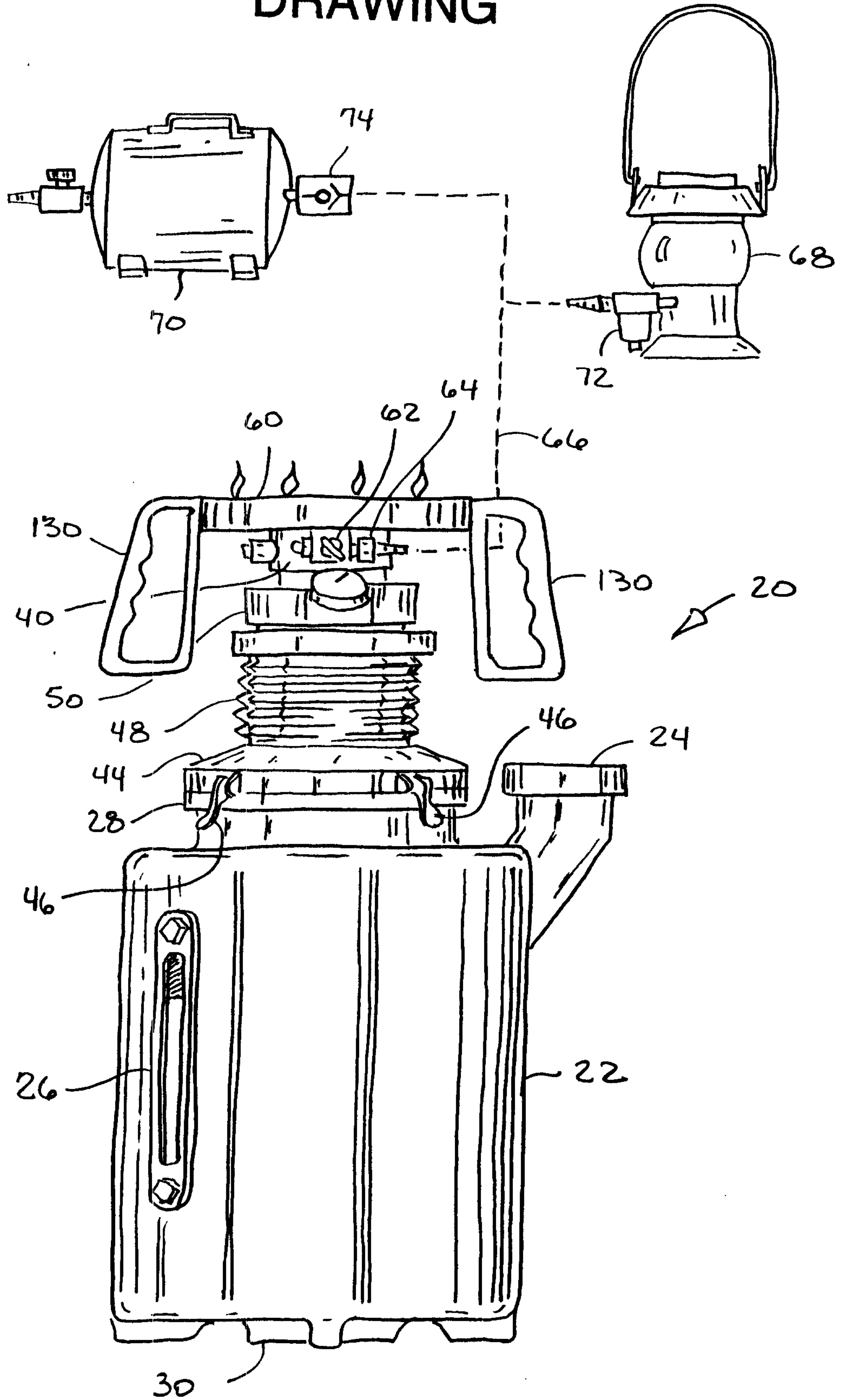

FIG. 1

INFORMAL DRAWING

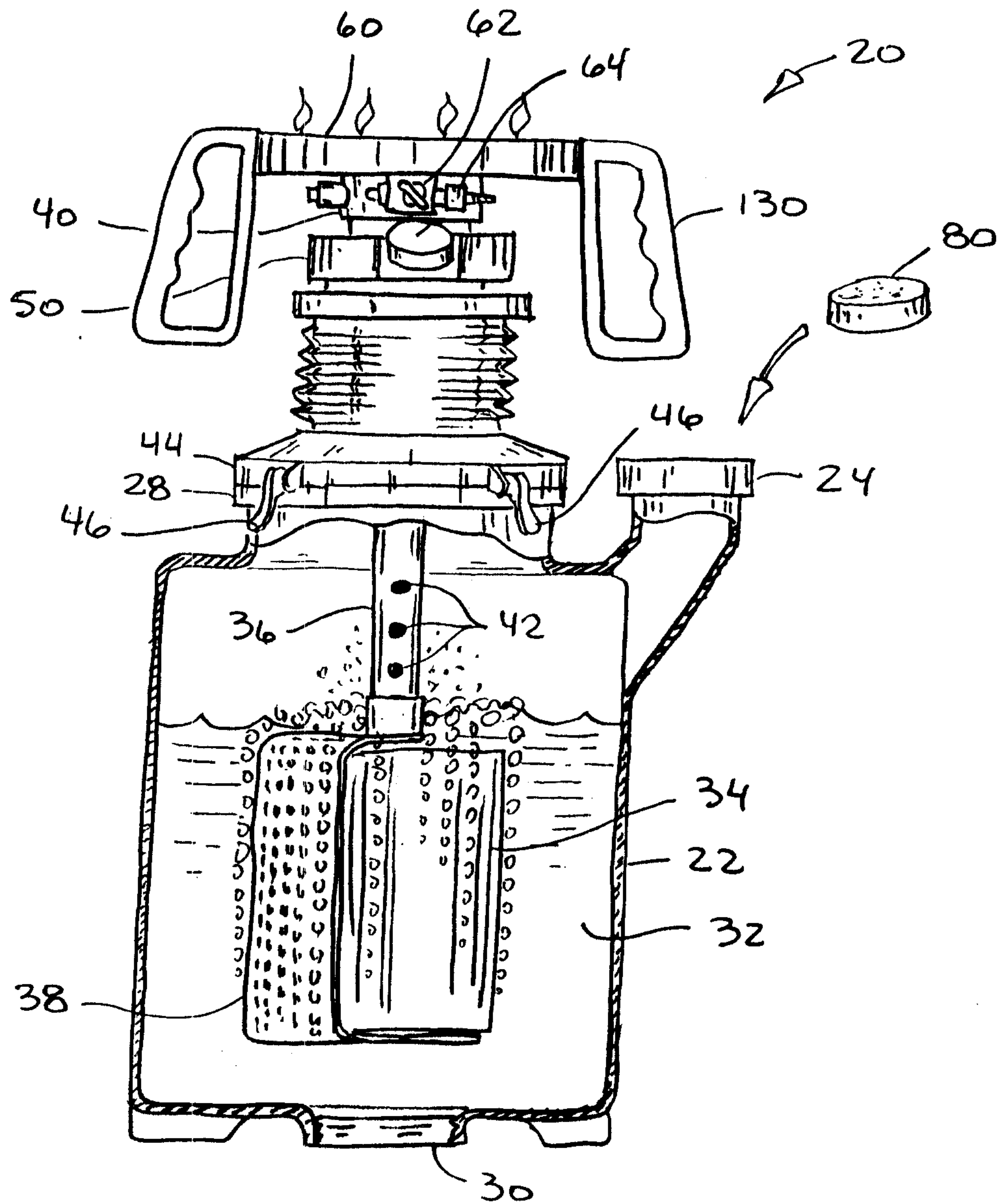

FIG. 2

INFORMAL DRAWING

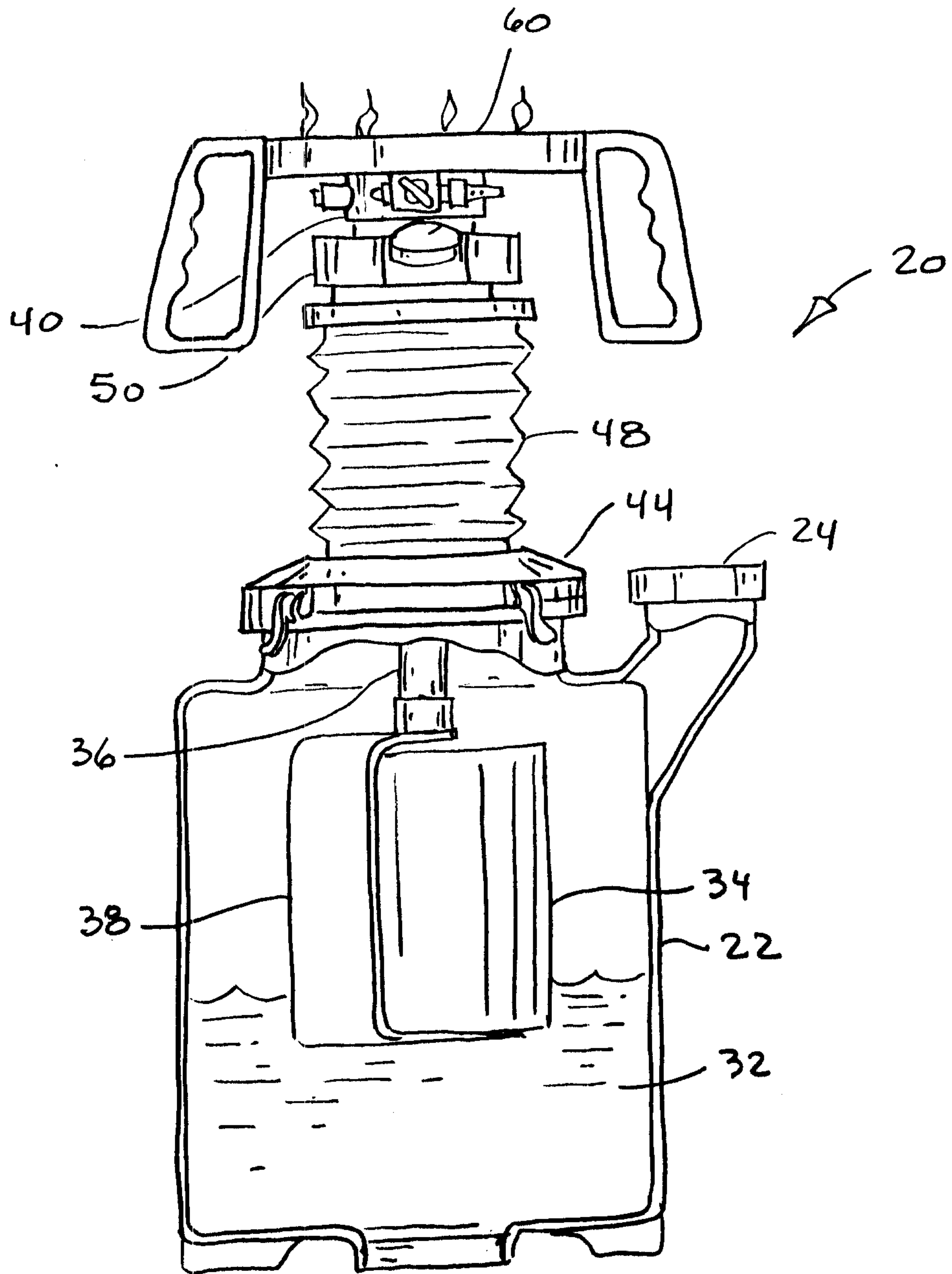
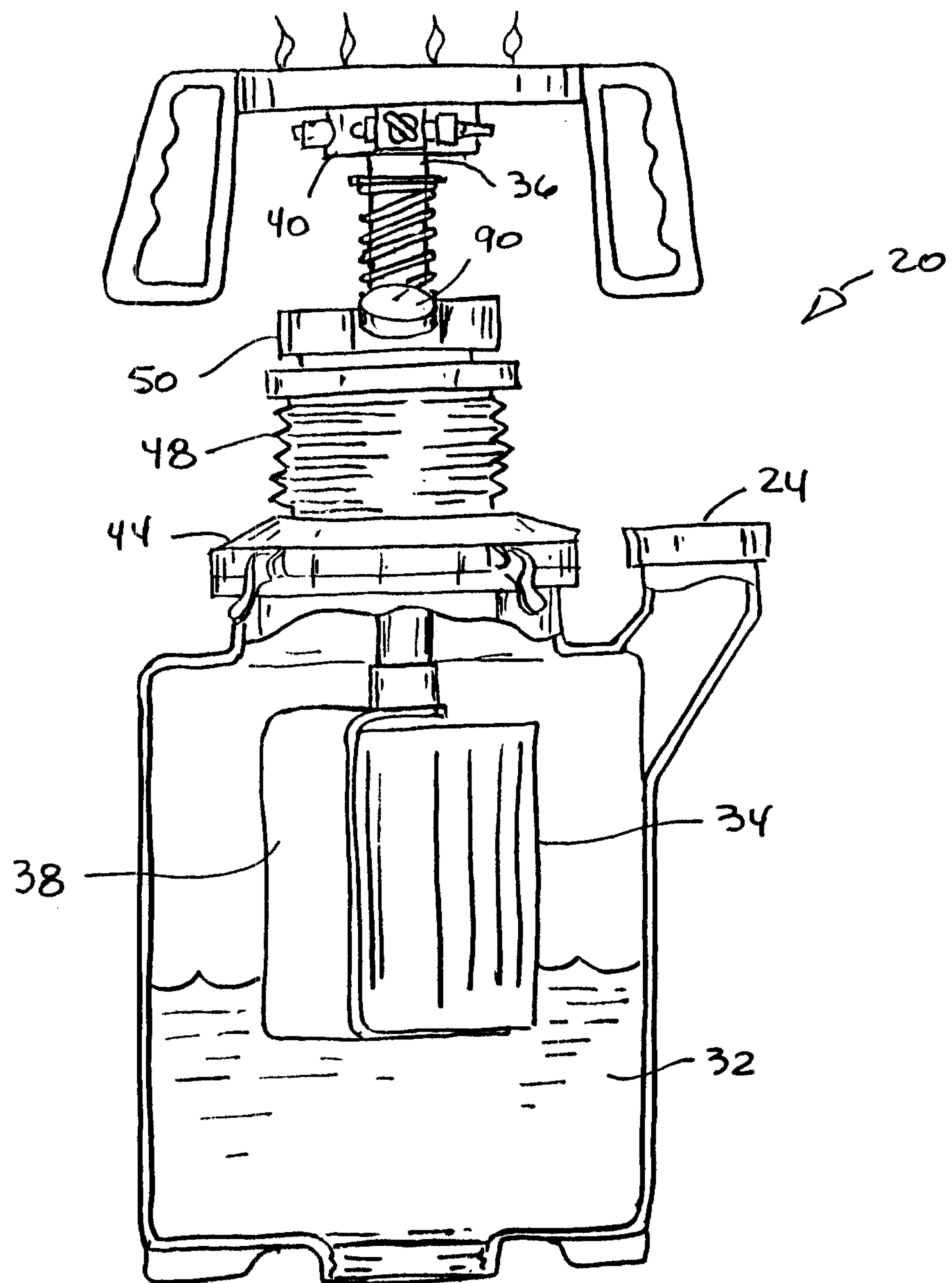

FIG. 3

INFORMAL DRAWING



INFORMAL
DRAWING

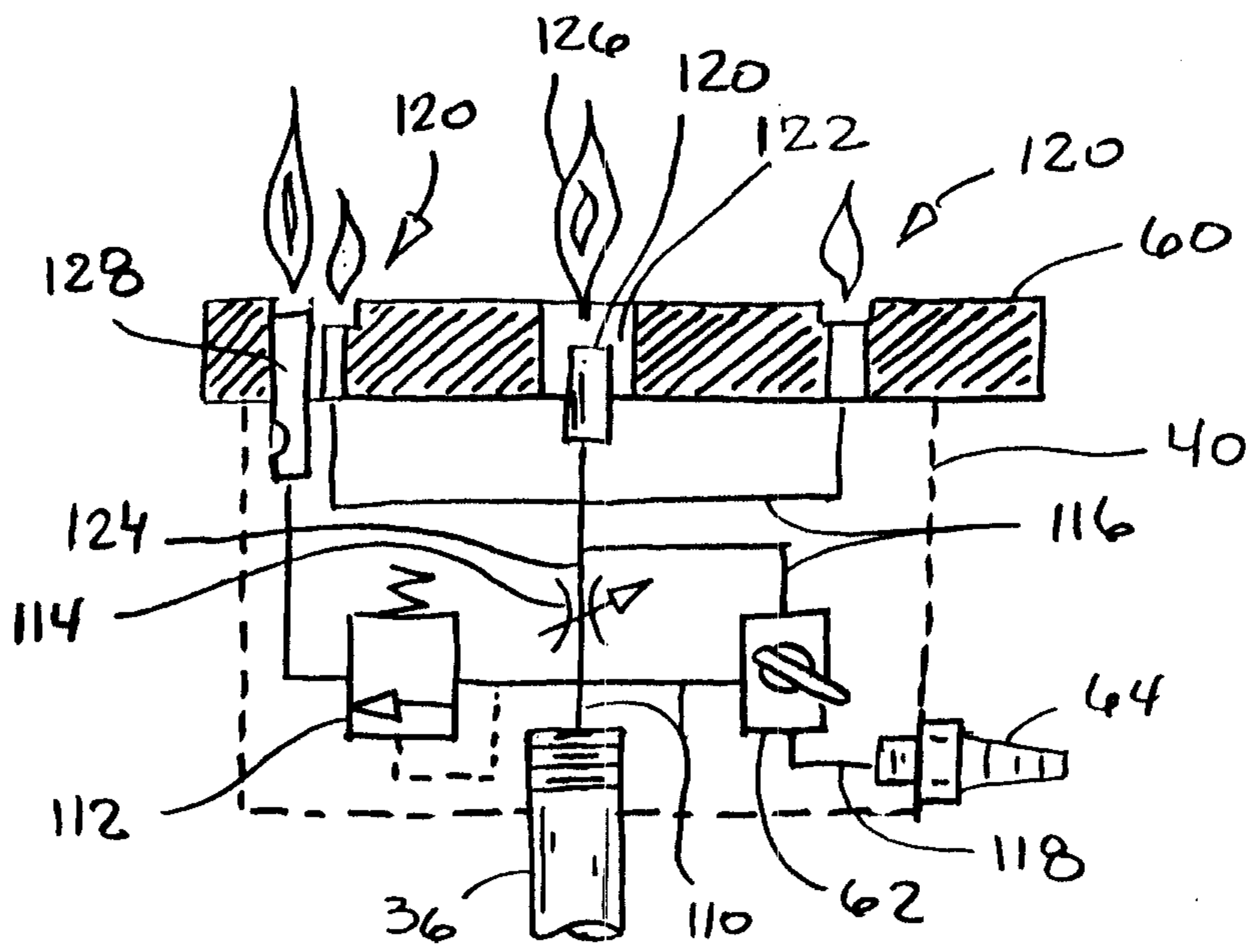

FIG. 5

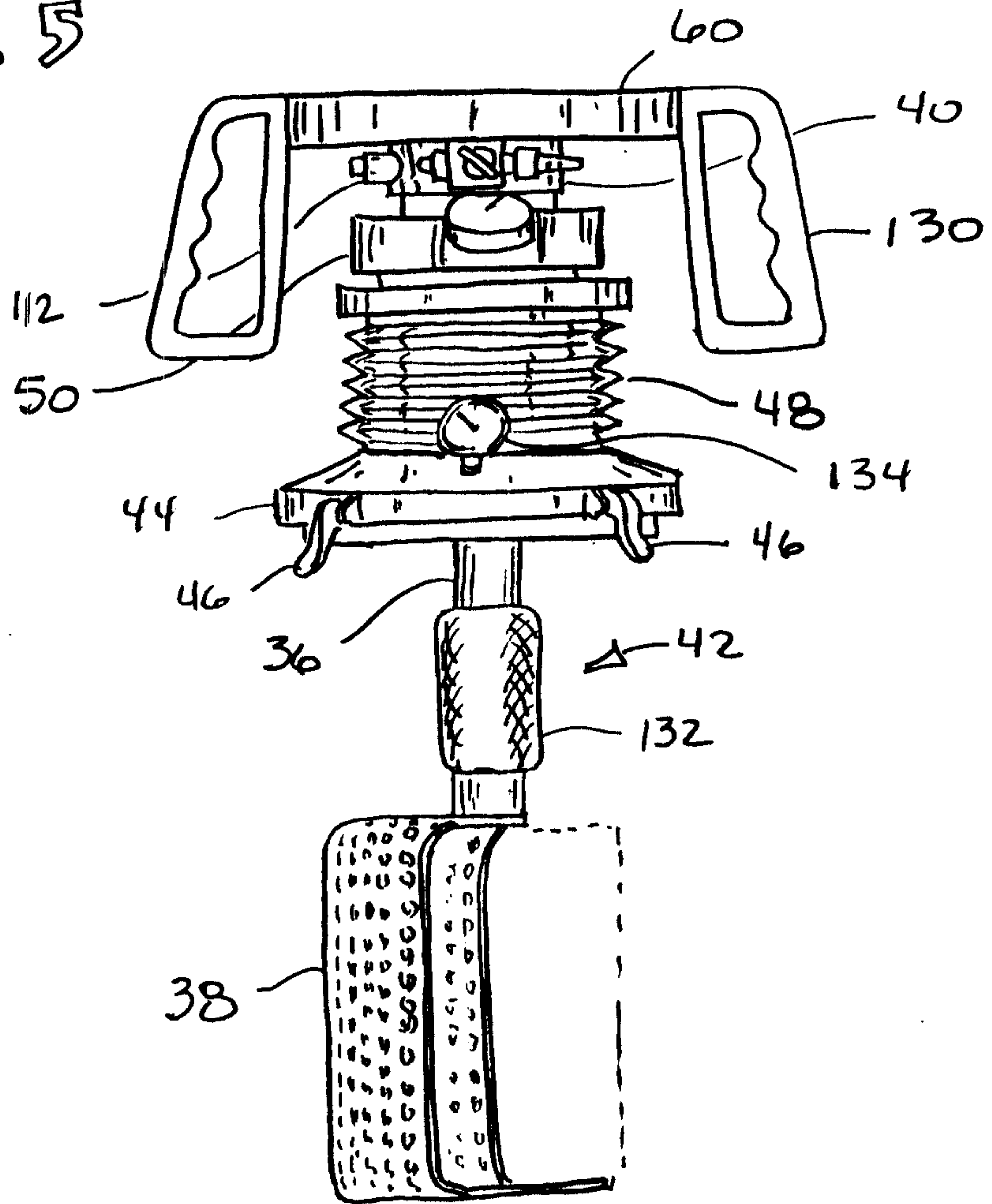

FIG. 6

INFORMAL
DRAWING

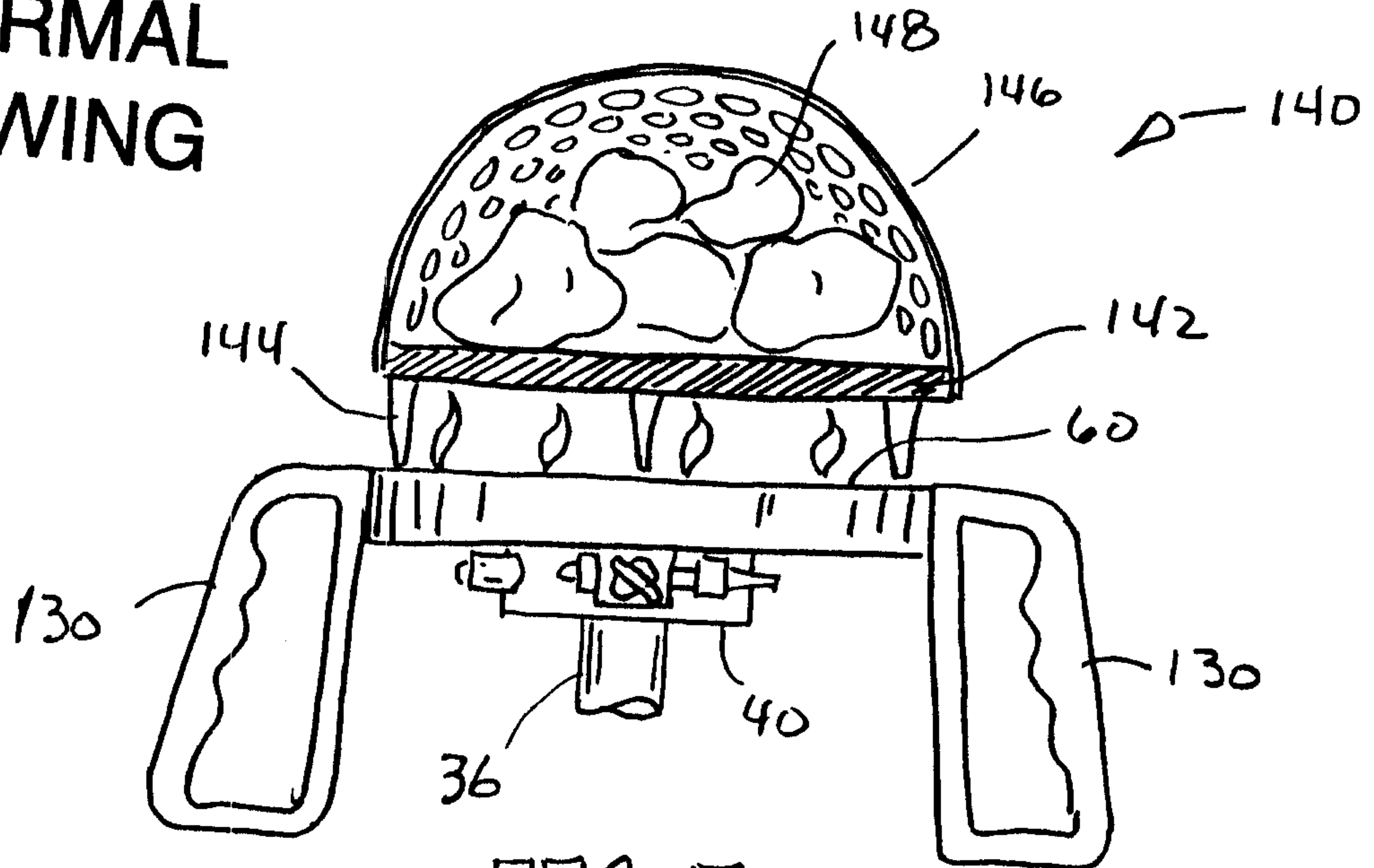

FIG. 7

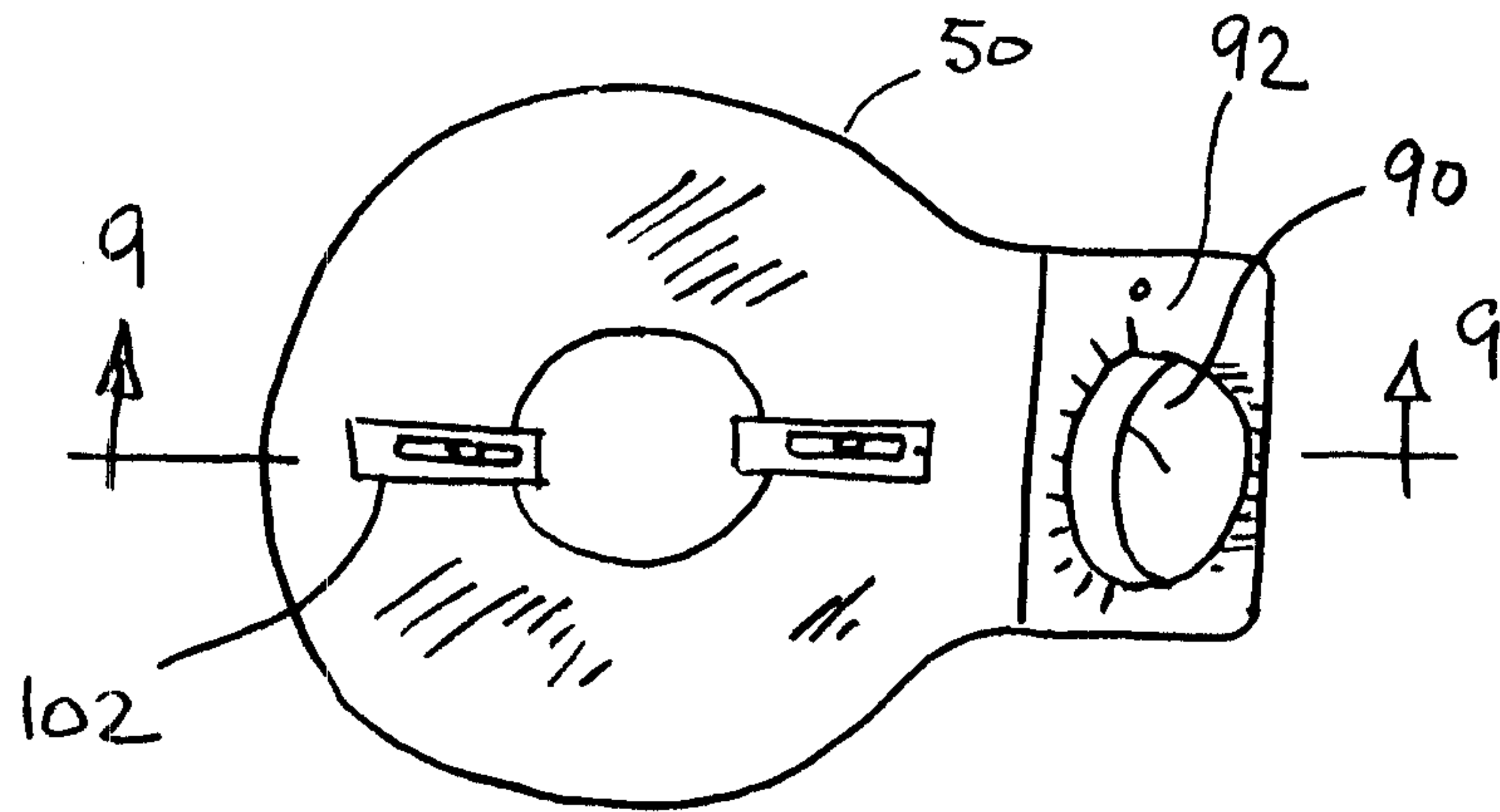

FIG. 8

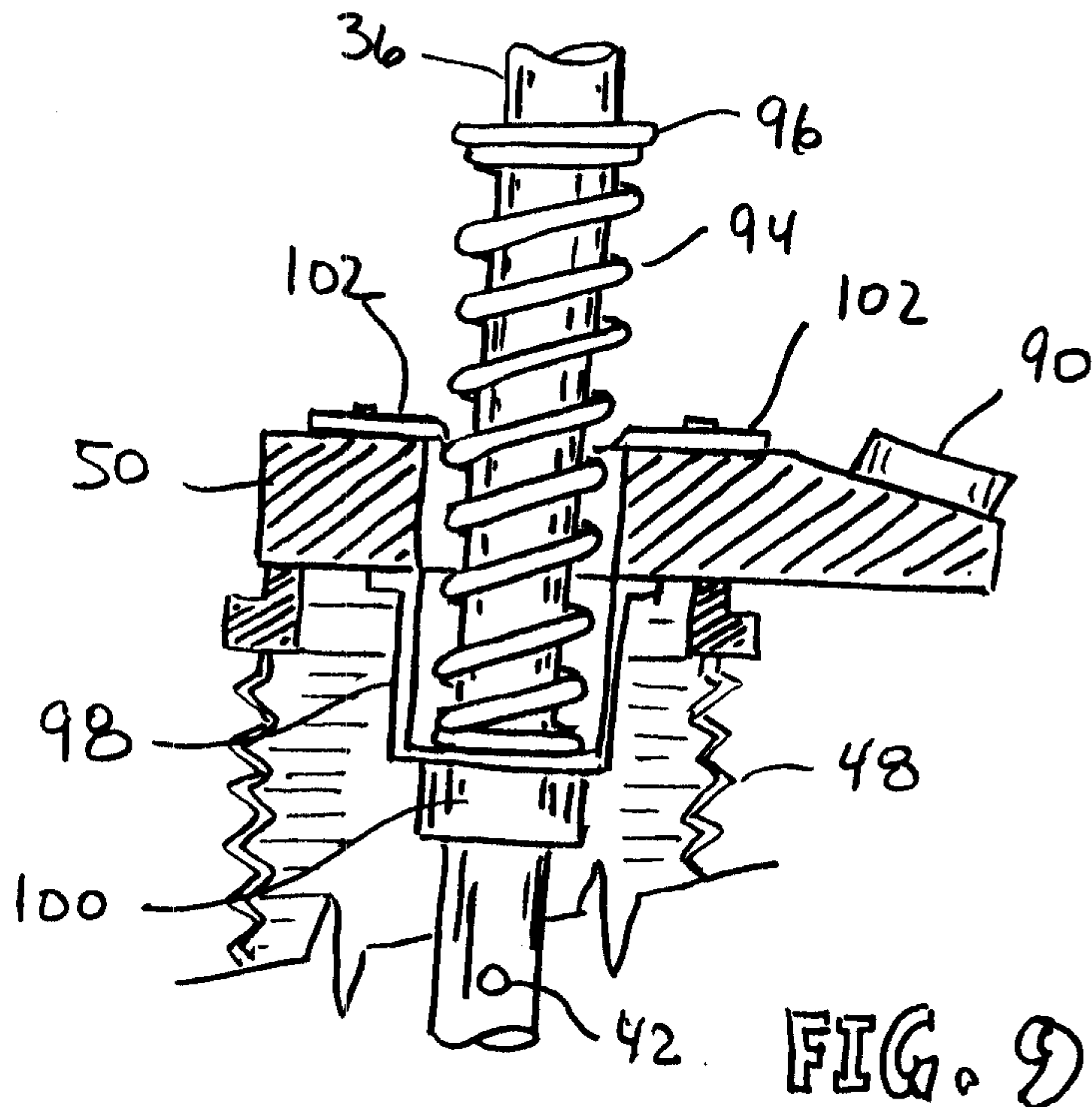

FIG. 9

INFORMAL
DRAWING

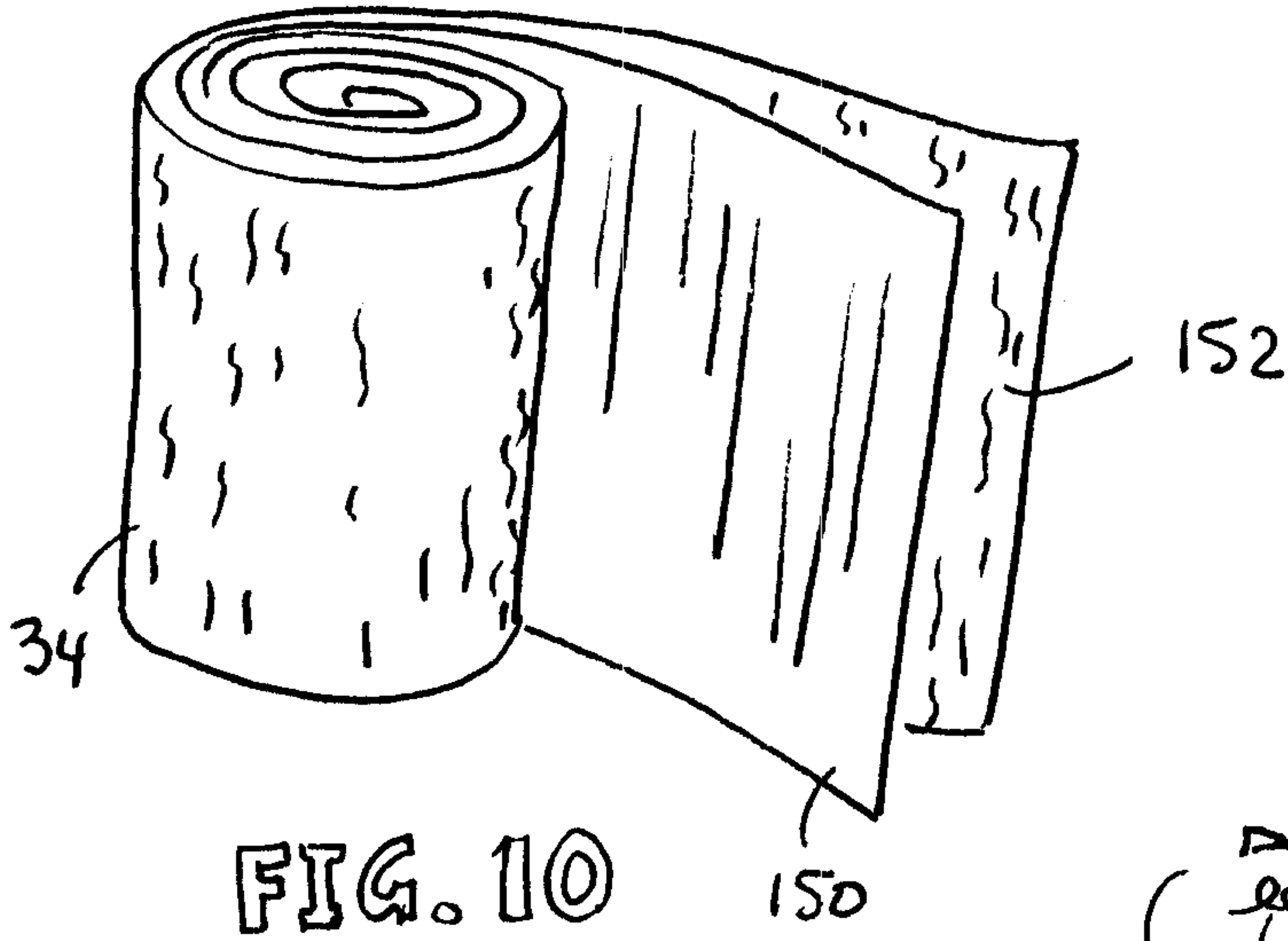

FIG. 10

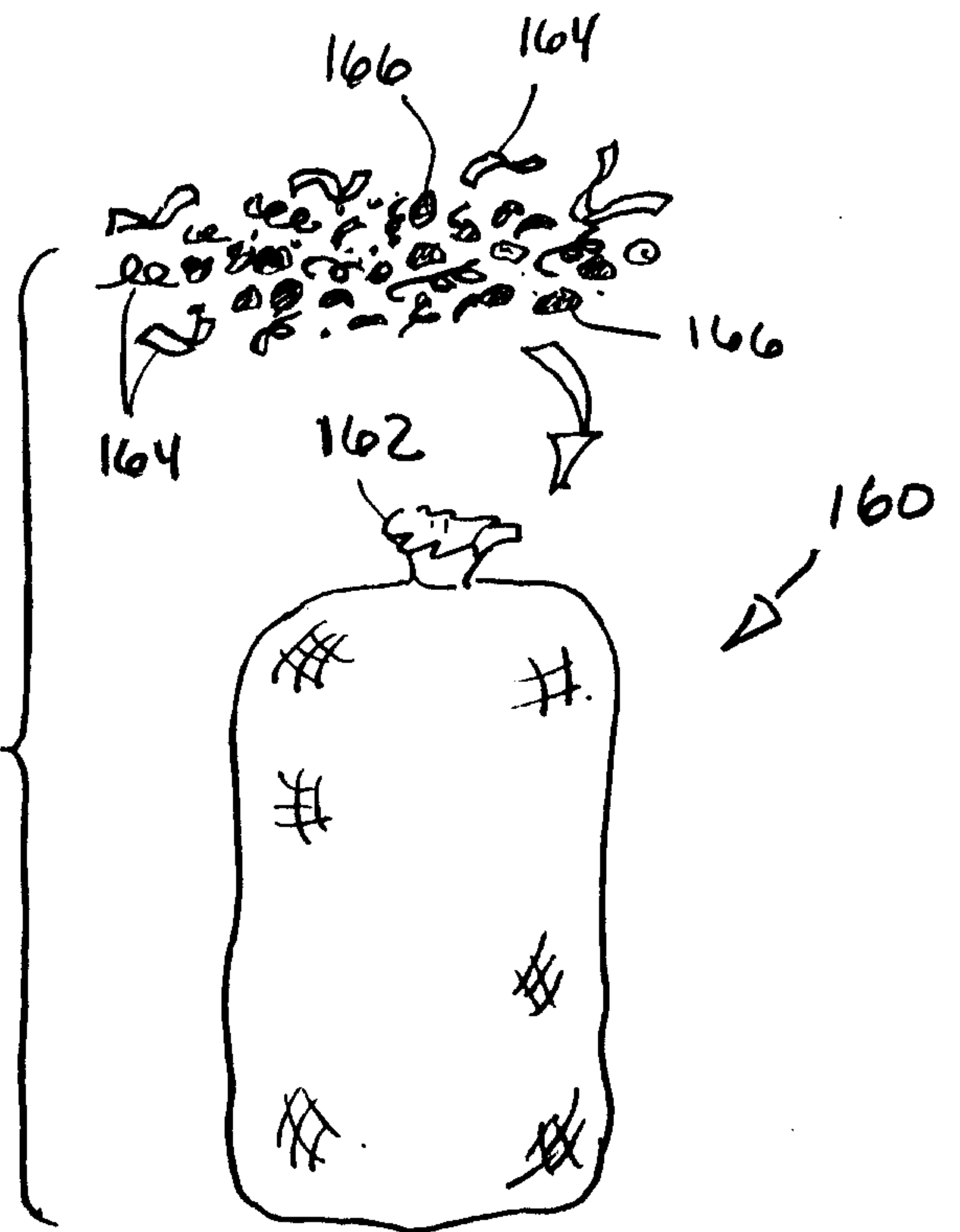

FIG. 11

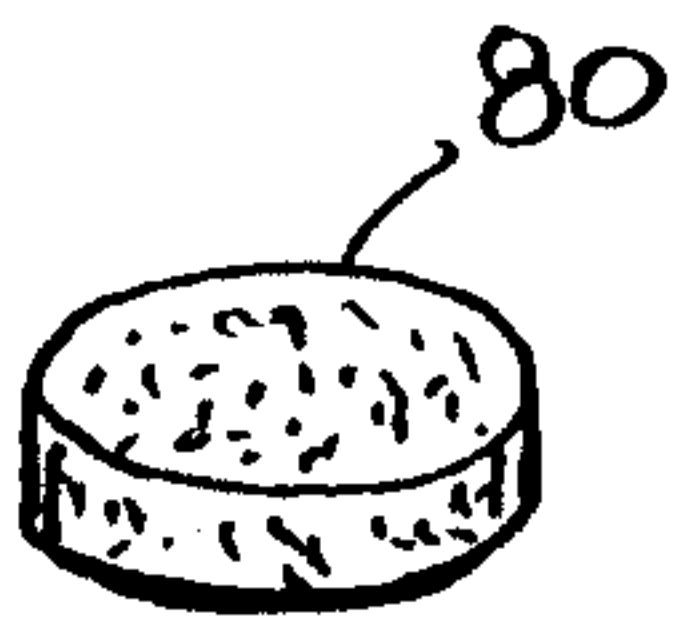

FIG. 12

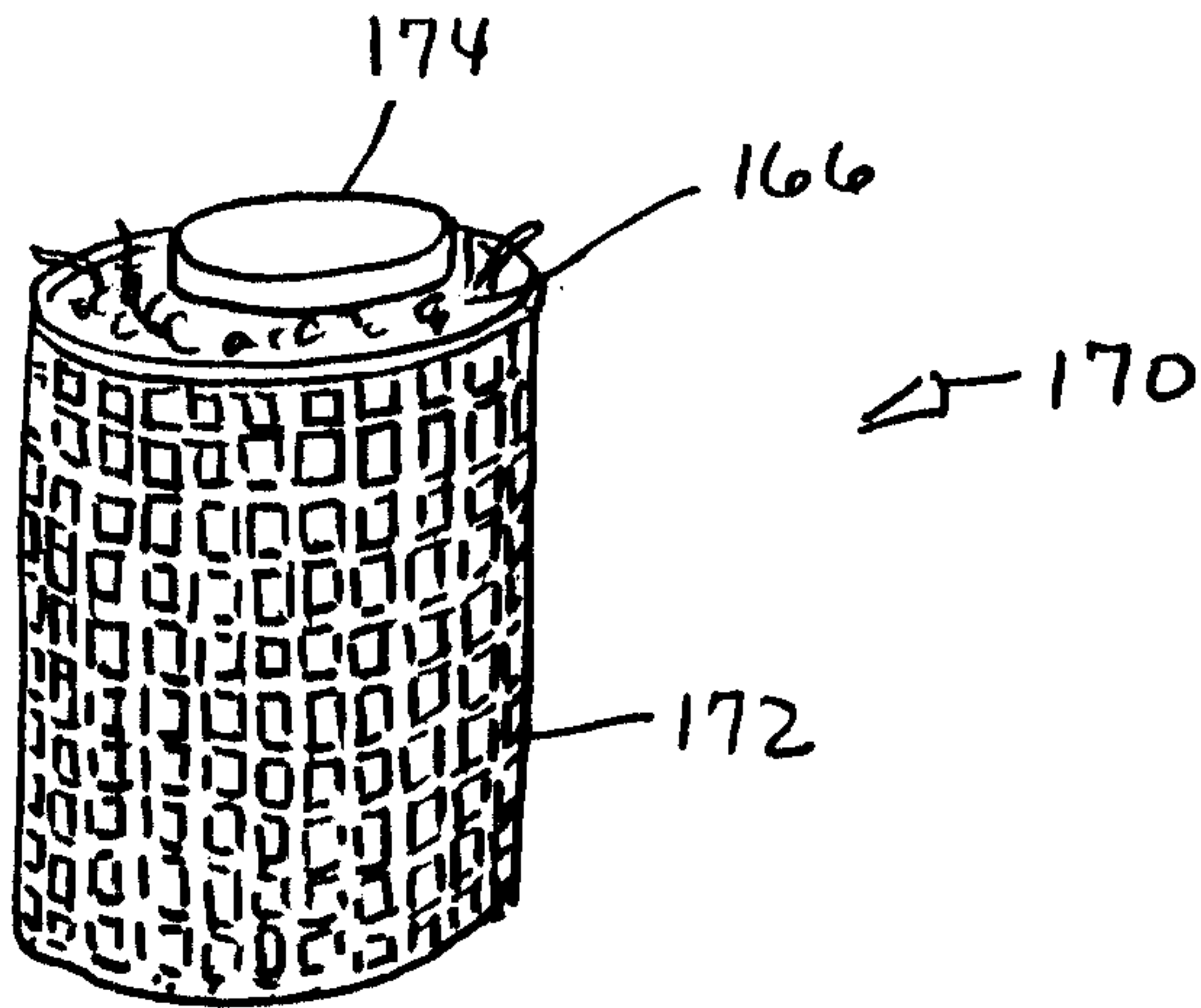

FIG. 13

INFORMAL
DRAWING

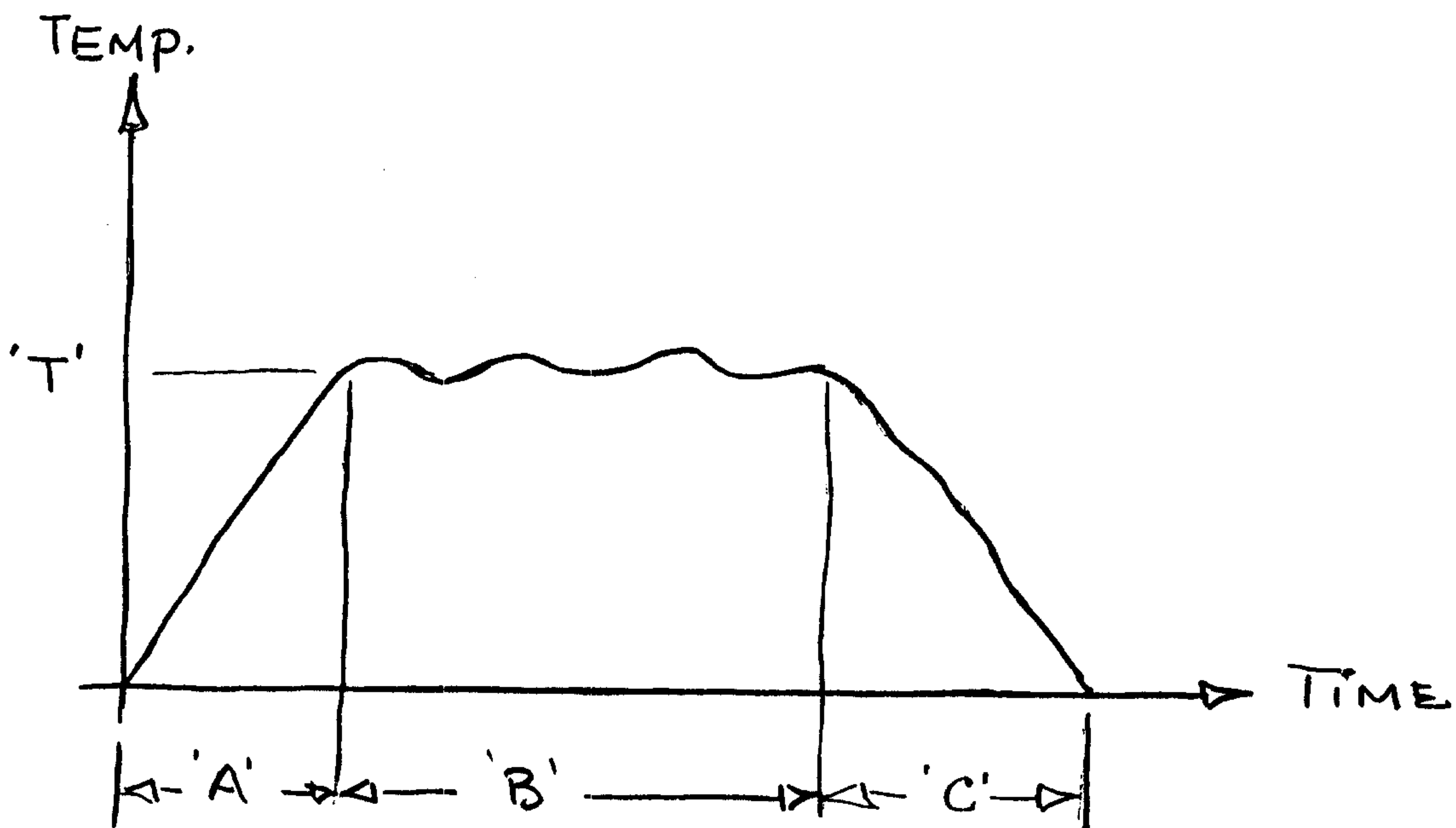

FIG. 14

