

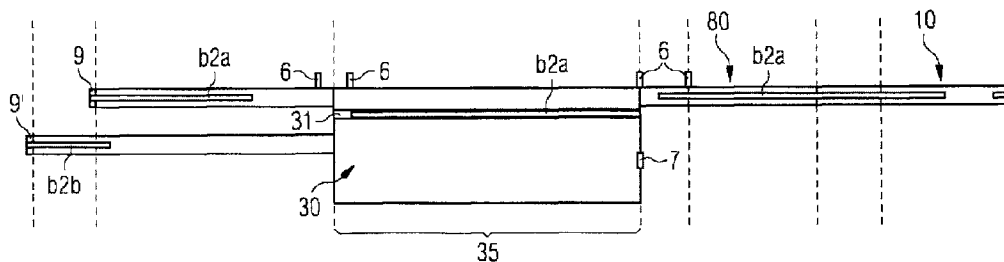

(86) Date de dépôt PCT/PCT Filing Date: 2015/05/04
 (87) Date publication PCT/PCT Publication Date: 2015/11/19
 (45) Date de délivrance/Issue Date: 2022/07/12
 (85) Entrée phase nationale/National Entry: 2016/08/30
 (86) N° demande PCT/PCT Application No.: EP 2015/059676
 (87) N° publication PCT/PCT Publication No.: 2015/173043
 (30) Priorité/Priority: 2014/05/13 (EP14425057.8)

(51) Cl.Int./Int.Cl. *B21B 1/46* (2006.01),
B21B 1/18 (2006.01), *B21B 31/10* (2006.01),
C21D 9/00 (2006.01), *F27B 9/24* (2006.01)
 (72) Inventeurs/Inventors:
 COLOMBO, EZIO, IT;
 HOHENBICHLER, GERALD, AT;
 KLUGE, JENS, DE;
 MORTON, JEFFREY, AT;
 PENNERSTORFER, PAUL, AT
 (73) Propriétaire/Owner:
 PRIMETALS TECHNOLOGIES AUSTRIA GMBH, AT
 (74) Agent: SMART & BIGGAR LLP

(54) Titre : APPAREIL ET PROCEDE POUR LA PRODUCTION DE PRODUITS METALLIQUES LONGS
 (54) Title: APPARATUS AND METHOD FOR PRODUCTION OF LONG METAL PRODUCTS



(57) Abrégé/Abstract:

An apparatus (100) and method for the production of elongated metal products such as bars: A rolling mill (10) with at least one rolling stand (5); a casting station (20) with at least a first casting line (2a) and at least a second casting line (2b), each line (2a, 2b) produces respective elongated intermediate products (b2a, b2b), such as billets. The first casting line(s) (2a) is directly aligned with the rolling mill (10), the first casting line(s) (2a) feeds the rolling mill(10) with a fully continuous casting strand or with cast elongated intermediate products. The second casting line(s) (2b) is not aligned with the rolling mill (10). A bidirectional transfer device (30) transfers elongated intermediate products (b2b) of the second casting line(s) (2b) alternatively in a first direction from the second casting line(s) (2b) to the first casting line(s) (2a) to align the elongated intermediate product (b2b) with the rolling mill (10) or in a second direction from the second casting line(s) (2b) to a cooling bed (40).

55910-71

ABSTRACT

An apparatus (100) and method for the production of elongated metal products such as bars: A rolling mill (10) with at least one rolling stand (5); a casting station (20) with at least a
5 first casting line (2a) and at least a second casting line (2b), each line (2a, 2b) produces respective elongated intermediate products (b2a, b2b), such as billets. The first casting line(s) (2a) is directly aligned with the rolling mill (10), the first casting line(s) (2a) feeds the rolling mill (10)
10 with a fully continuous casting strand or with cast elongated intermediate products. The second casting line(s) (2b) is not aligned with the rolling mill (10). A bidirectional transfer device (30) transfers elongated intermediate products (b2b) of the second casting line(s) (2b) alternatively in a first
15 direction from the second casting line(s) (2b) to the first casting line(s) (2a) to align the elongated intermediate product (b2b) with the rolling mill (10) or in a second direction from the second casting line(s) (2b) to a cooling bed (40).

55910-71

1

Apparatus and method for production of long metal products

CROSS-REFERENCE TO RELATED APPLICATIONS

5 [0001] The present application is a 35 U.S.C. §§ 371 national phase conversion of PCT/EP2015/059676, filed May 4, 2015 which claims priority of European Patent Application No. 14425057.8, filed May 13, 2014. The PCT International Application was published in the English language.

10

TECHNICAL FIELD

[0002] The present invention relates to an apparatus and a method for production of elongated metal products such as bars, rods, wire and the like.

15

TECHNICAL BACKGROUND

[0003] The production of elongated metal products is generally realized in a plant by a succession of steps. Normally, in a first step, metal scrap is provided as feed material to a
20 furnace which heats up the scrap to reach the liquid status. Afterwards, continuous casting equipment is used to cool and solidify the liquid metal and to form a suitably sized strand.

[0004] Such a strand may then be cut to produce a suitably
25 sized intermediate elongated product, typically a billet, to create feeding stock for a rolling mill. Normally, such feeding stock is then cooled down in cooling beds. Thereafter, a rolling mill is used to transform the feed stock, or billet, to a final elongated product, for instance rebar, available in
30 different sizes which can be used in mechanical or construction industry. To obtain this result, the feed stock is pre-heated

55910-71

2

to a temperature which is suitable for entering the rolling mill where it is to be rolled by rolling equipment including multiple stands. By rolling the feed stock through these multiple stands, the feed stock is reduced to the desired cross section and shape. The elongated product resulting from the former rolling process is normally cut when it is still in a hot condition, then cooled down in a cooling bed, and finally cut at a commercial length and packed to be ready for delivery to a customer.

10

[0005] In the following, an endless operational mode of a plant for manufacturing elongated metal products will denote a plant arrangement wherein a direct, continuous link is established between a casting station and the rolling mill which is fed with the product of the casting procedure. In other words, the strand of intermediate product leaving the casting station is rolled by the rolling mill continuously along one casting line. Normally, when a plant operates in a fully endless mode, the continuous strand that is cast from the casting station along a corresponding casting line is fed to rolling mill, without being preliminarily cut into billets. In this case, the elongated intermediate product comes to effectively coincide with the strand leaving the casting station.

25

[0006] In the following, a semi-endless operational mode of a plant for manufacturing of elongated metal products denotes a plant arrangement, wherein the rolling mill is also fed with supplemental, normally preliminarily cut intermediate products which are originally external to the casting line directly linked to the rolling mill. Such intermediate products can be fed and inserted into the casting line which is directly

30

55910-71

3

connected to the rolling mill, for instance, by sourcing them from further casting lines which are not necessarily themselves aligned with and directly linked to the rolling mill.

5 [0007] When operating according to a so called endless mode, the rolling mill is arranged aligned with the strand produced by the billet caster. As a result, a manufacturing plant comprising direct casting and direct feeding of rolling mills, when dimensioned and conceived for operating in such endless
10 mode, should ideally be as short as possible, in order to optimally utilize the internal heat of the just cast billets. Following this construction constraint, the space interposed between a first shear, normally located at the end of the caster, and an entrance into a customary intermediate billet
15 heating device should be kept as short as possible. The compactness requirement remains naturally very desirable also when operating in a semi-endless mode.

[0008] Document WO 2012/013456 A2 discloses a plant comprising
20 two casting lines producing two strands of intermediate product, such as billets. Such a plant provides a preliminary solution to the problem of better exploiting the hourly production rate of the steelmaking plant upstream, which is usually higher than the conventional production rate of rolling
25 mills downstream. However, the layout of this plant is such that only one of two strands can be rolled to obtain a final product. By adopting a by-pass solution according to the concept disclosed in WO 2012/013456 A2, if there is at least a further strand available exiting from a caster, the additional
30 billets resulting from such further strand are just transferred onto a conventional cooling bed. The billets which have been

55910-71

4

cooled down on such bed are then normally intended for direct sale and are not rolled according to an endless operational mode. Such a plant does therefore not provide optimal operational flexibility to be run either in a fully endless mode or in semi-endless mode.

[0009] In particular, such a plant does not allow fully exploiting the potentialities of a multi-strand caster in a way that the rolling mill throughput is actually optimized, for the production of as many rolled, final elongated products as desired.

[0010] On the other hand, existing plants which are able to operate in the so called semi-endless mode cannot ensure that the operation of inserting extra-billets into the casting line directly connected to the rolling mill happens in a cobble-free fashion and with full control over the billets' movements, both along the additional casting lines from which the supplemental billets are sourced and, especially, along the main casting line which is directly connected to the rolling mill.

[0011] None of the existing plants which can operate in a semi-endless mode and have a multi-strand caster effectively deal with the problem of avoiding that interferences are created between billets along the casting lines.

[0012] As a result of such lack of control, in current plants operating in a semi-endless mode, the workflow can be disrupted, in the feeding direction of the rolling mill as well as in the additional casting lines which are not aligned with the rolling mill.

55910-71

5

[0013] Thus, a need exists in the prior art for an apparatus, and a corresponding method, for the production of elongated rolled products from a multiplicity of casting lines which encompasses a semi-endless operating mode, wherein the rolling mill output and the production rate of intermediate elongate products such as billets are optimized and happen in a cobble-free way, that is with no interferences between billets on one same casting line or across casting lines as a result of billet transfer.

SUMMARY OF THE INVENTION

[0014] Accordingly, a major objective of the present invention is to provide a flexible plant and a method for production of long metal products which allows switching between endless and semi-endless production mode. The present invention allows thus to exploit at the best, in terms of output, the potentiality of a multi-line caster in direct association with a rolling mill and, at the same time, offers the option to seamlessly produce intermediate elongate products, such as billets to be sold as such.

[0015] The plant according to the present invention operates in a way that it can swiftly adapt to different production requirements and circumstances, dependent on actual need of final elongated products, such as rolled rebars, or intermediate elongated products, such as billets as such. This way, production can be adjusted to the current, actual requests, for instance according to commission orders.

30

55910-71

6

[0016] The present invention allows increasing rolling throughput by feeding the rolling mill with as many billets as possible from at least two, three or even N strands, without losing control over the production process and specifically
5 over the billet movements.

[0017] A companion objective of the present invention is to allow reaching the above flexibility while at the same time keeping the overall plant very compact.

10

[0018] In this respect, the movements of the billets along the casting line directly connected to rolling mill and the movements of billets on the additional casting lines are achieved and controlled according to a special arrangement
15 which does not have negative consequences in terms of overall length and general bulk of the plant.

[0019] In particular, such movements of elongated intermediate products, both across the casting line directly linked to the rolling mill and the additional casting lines and from the
20 additional casting lines to a cooling bed, can be advantageously executed by operating the same double-acting transfer means, positioned at the same level along the overall development of the plant production line.

25

[0020] There is no need for an add-on to the plant resulting in a supplementary length least equal to the length of a billet, like customary solutions would instead imply.

[0021] It is also by adopting this arrangement measure that the present invention ensures that the temperature of the cast billets or intermediate elongated products does not decrease too much along the production lines. Less power is thus needed to re-heat the intermediate elongated products to a temperature that is suitable for subsequent hot rolling, in compliance with more and more relevant energy saving measures and ecological requirements.

[0022] A companion objective of the present invention is to readily switch between semi-endless and endless production modes on the casting line directly connected to the rolling mill by use of a robust system which does not present unnecessary complications, thus reducing need for maintenance and extra-safety measures.

[0023] Decoupling the billet transfer means from the billet heating means according to the plant arrangement of the present invention advantageously ensures that the mechanical and control parts of the bidirectional, also denotable as double acting, billet transfer means are not affected by high temperatures.

[0024] Easier accessibility to these transfer means, even during operation, is achieved.

[0024a] According to one aspect of the present invention, there is provided an apparatus for production of elongated metal products, said apparatus comprising: a rolling mill comprising at least one rolling stand, a casting station comprising at least a first casting line and at least a second casting line,

each line being operable to produce respective continuous strands and elongated intermediate products, wherein: the first casting line is directly aligned with the rolling mill, said first casting line being configured to feed the rolling mill with continuous casting strands or cast elongated intermediate products, and the second casting line is not aligned with the rolling mill; said apparatus further comprises: bidirectional transfer means for transferring elongated intermediate products of the second casting line in a first direction from said second casting line to said first casting line to align said elongated intermediate product with the rolling mill; said bidirectional transfer means is positioned over one cross-transfer area wherein: said bidirectional transfer means are foreseen for transferring elongated intermediate products of the second casting line in a second direction from said at least second casting line to a cooling bed; the components of said bidirectional transfer means are substantially at a same level along said first and said second casting lines; an automation control system comprising sensor means at least along said first casting line cooperating with said bidirectional transfer means; at least three sensors along the first casting line are provided as said sensor means, whereas one first sensor of said at least three sensors is positioned within a range of 1-6 meters upstream of an entrance to the cross-transfer area; one second sensor is positioned within the cross-transfer area soon after the entrance of the cross-transfer area; one third sensor is positioned within the cross-transfer area at an exit of the cross-transfer area; said bidirectional transfer means comprises a lifting device for carrying elongated intermediate products, cooperating with

first moving means, for transferring said elongated intermediate products of the second casting line in the first direction; and second moving means for transferring said elongated intermediate products of the second casting line in the second direction; wherein said lifting device, first moving means and second moving means are positioned over the cross-transfer area substantially spatially at the same level along said first and second casting lines.

10 **[0025]** Other objectives, features and advantages of the present invention will be now described in greater detail with reference to specific embodiments represented in the attached drawings, wherein:

15 **BRIEF DESCRIPTION OF THE DRAWINGS**

- FIG. 1 is a schematic, general view of an embodiment of the apparatus according to the present invention, wherein the casting station produces a first and a second casting strand, substantially parallel to each other, travelling on respective casting lines;

20 - FIG. 2 is a schematic view of a portion of the apparatus of Figure 1, showing a particular moment of the cross-transfer of an elongated intermediate product, such as a billet, from the second casting line to the first casting line;

55910-71

9

- FIGS. 3A, 3B, 3C, 3D and 3E are schematic representations of a first sequence of steps executed by the apparatus of FIG. 1, showing how the elongate intermediate products moving on the first casting line are complemented with
5 additional elongated intermediate products from the second casting line, when minimal conditions of non-interference are satisfied;
- FIGS. 4A, 4B, 4C 4D and 4E are schematic representations of a second sequence of steps executed by the
10 apparatus of FIG. 1, showing how elongated intermediate products from the second casting line are cross-transferred to a cooling bed, when minimal conditions of non-interference are not satisfied either on the second casting line or on the first casting line;
- 15 - FIG. 5 is a schematic representation of one of the steps which can be performed by the apparatus of FIG. 1, based on sensor means' input, showing how one elongated intermediate product from the second casting line is kept within a cross-transfer area, until next minimal conditions of non-
20 interference are verified on the first casting line for concurrent transfer to the first casting line;
- FIG. 6 is a schematic representation of one of the steps which can be performed by the apparatus of FIG. 1, showing how a lifting device of bidirectional transfer means of
25 the apparatus according to the present invention, having carried an elongated intermediate product from the second casting line to the first casting line, is brought back towards a waiting position along the second casting line
- FIG. 7 is a schematic representation of one of the
30 steps which can be performed by the lifting apparatus of FIG. 6

55910-71

10

when two elongated intermediate products find themselves concurrently within the cross-transfer area along the second casting line, showing how the lifting device engages with and carries one of the elongated intermediate products to be transferred to a cooling bed.

DESCRIPTION OF EMBODIMENTS

[0026] In the FIGS., like reference numerals depict like elements.

10

[0027] With reference to FIG. 1, an apparatus 100 for the production of elongated metal products such as bars, rods or the like, comprises:

- a rolling mill 10 comprising at least one rolling stand 5; and
- a casting station 20 comprising at least a first casting line 2a and at least a second casting line 2b.

[0028] Each of the casting lines 2a and 2b is operable to produce respective continuous strands and/or elongated intermediate products b2a, b2b in FIG. 2, such as billets.

[0029] In FIGS. 1 and 2, the first casting line 2a is directly aligned with the rolling mill 10 and is configured to feed such rolling mill 10 with cast continuous strands or elongated intermediate products.

[0030] According one of the functioning concepts of the present invention, the elongated intermediate products which eventually

55910-71

11

feed the rolling mill 10 can advantageously be billets b2a as well as billets b2b.

[0031] The at least one second casting line 2b is, instead, not directly aligned with the rolling mill 10.

[0032] In FIG. 2, the apparatus 100 according to the present invention further advantageously comprises double acting, or bidirectional, transfer means 30 for transferring elongated intermediate products across the multiplicity of casting lines.

[0033] In particular, for the specific embodiment hereby illustrated, such bidirectional transfer means 30 allows the cross-transfer of elongated intermediate products b2b of the second casting line 2b in two possible, preferably opposite directions.

[0034] Specifically, the transfer of billets b2b can be executed in a first direction, from the second casting line 2b to the first casting line 2a, in order to align the elongated intermediate product b2b with the rolling mill 10, to be finally rolled according to a semi-endless operating mode.

[0035] Otherwise, alternatively, the special bidirectional transfer means 30 of the apparatus 100 according to the present invention can transfer billets b2b in a second direction, preferably substantially opposite to the first direction, from the at least second casting line 2b to a cooling bed 40.

[0036] Billets b2b which are transferred to a cooling bed according to this second transfer option are then meant to be

55910-71

12

sold as intermediate product, that is billets as such, to be then further processed, possibly on a different site.

[0037] In this way, the overall, multi-line billet

5 manufacturing plant can be switched between different operating modes. In particular, the plant comprising the claimed apparatus 100 can be automatically, swiftly switched, for instance, between:

- a semi-endless operating mode wherein an exchange of
10 elongated intermediate products between second casting line 2b and first casting line 2a is implemented, to achieve a consistently higher output of the rolling process; and
- a fully endless operating mode only on the first casting
15 line aligned with the rolling mill 10, usually with the benefit of less specific reheating energy consumption and/or better material yield by the whole process.

[0038] On the one hand, when functioning according to a semi-

endless mode, billets b2a originally put from the casting
20 station 20 on the first casting line 2a are complemented with cross-transferred billets b2b from (at least) a second casting line 2b, as shown in FIG. 6, thus obtaining that these cross-transferred billets arrive at the rolling mill 10. Hence all billets from both casting lines can be rolled.

25

[0039] On the other hand, when the first casting line operates in a fully endless mode, billets b2b originally on the second casting line 2b are, instead, transferred onto a cooling bed 40
in FIGS. 4D, 4E and do not reach the rolling mill 10, and are
30 available to be sold or for later heating of other billets.

55910-71

13

Hence, maximum material yield together with minimum specific heating energy consumption is obtained. The operating mode of the first casting line can be turned to a fully endless mode when for example, commission orders demand that, from multi-
5 strand continuous casting production. The billets obtained from the non-aligned strands may be sold as mere, unrolled intermediate product.

[0040] According to the present invention, switching from a
10 semi-endless operating mode to an operating mode which is essentially endless along the first, aligned casting line is also preferably dependent on the relative movement of the elongated intermediate products and, ultimately, on risk of interference among billets on the first casting line and/or on
15 the second casting line.

[0041] The switching between operating modes can be therefore advantageously controlled in function of minimal conditions of non-interference between billets, as explained more in depth
20 below in connection with the description of the process steps according to the present invention.

[0042] In fact, the present invention allows to optimize and customize production output, ensuring cobble-free conditions on
25 the first casting line and on the other, additional casting lines, by avoiding interferences between billets on the first casting line and/or on the further casting lines. Such undesirable interferences would otherwise cause problems both as a result of subsequent, incoming billets on the same casting
30 line or as a result of the insertion of additional billets into the first casting line aligned with the rolling mill.

55910-71

14

[0043] The bidirectional transfer means 30 in FIGS. 2 and 6 of the apparatus 100 according to the present invention comprises preferably a lifting device 31 for carrying elongated
5 intermediate products b2b. Such lifting device can comprise an aptly designed billet seat.

[0044] Bidirectional, or double acting, transfer means can comprise first and second moving means cooperating with the
10 lifting device 31.

[0045] First moving means allow transferring the elongated intermediate products b2b of the second casting line 2b in a first direction from the second casting line 2b to the first
15 casting line 2a.

[0046] Second moving means allow transferring the elongated intermediate products b2b of the second casting line 2b in a second direction from the at least second casting line 2b to a
20 cooling bed 40. Such second moving means can be substantially the same as the first moving means and can differ from the latter just in that they are driven in the opposite direction as the first moving means.

[0047] In order to keep the overall apparatus 100 compact and to advantageously save space, all of the components of the bidirectional transfer means 30 according to the present invention are preferably positioned over one, same cross-transfer area 35 in FIGS. 2, 6 and 7. This means, for the
30 specific embodiment introduced, that the lifting device 31 the

55910-71

15

first moving means and the second moving means are preferably positioned over one, same cross-transfer area 35.

[0048] Lifting device 31 and moving means are therefore spatially
5 contained and grouped within a cross-transfer area or module, which
can have walls or can be entirely open-air, substantially at the
same level along the first and second casting lines. Being at the
same level with respect to the development of the casting lines
means substantially at the same plant section. In the context of
10 the present invention, the above mentioned same-level
positioning preferably implies that the components of the
double-acting transfer means are contained within a cross-
transfer area or module substantially at the same distance from
the casting mold or casting head of the casting station.

15

[0049] The cross-transfer area 35 preferably stretches over a
length which is the same as, or slightly longer than, the rated
maximum length of the elongated intermediate products b2b.
Thus, valuable space is gained and two functions, corresponding
20 to the double acting transfer means, are advantageously
encompassed within the same plant section.

[0050] The apparatus 100 according to the present invention
comprises an automation control system in FIGS. 2, 6 and 7
25 comprising special sensor means 6, 7, cooperating with the
bidirectional transfer means 30.

[0048] In any event, sensor means 6 are advantageously provided
at least along the first casting line 2a.

30

55910-71

16

[0049] The bidirectional transfer means 30 can be thus activated according to information collected by these sensors 6, 7.

5 [0050] Sensors 6,7 can be generic optical presence sensors, or more specifically, can be hot metal detectors designed to detect the light emitted or the presence of hot infrared emitting bodies, such as billets coming from continuous casting.

10

[0051] Sensors 6 along the first casting line 2a are preferably positioned within the cross-transfer area 35 and within a range of 1-6 meters upstream of the entrance to the cross-transfer area 35. The former range upstream of the entrance to the
15 cross-transfer area depends on typical billet length, typical billet speed and acceleration or deceleration thereof.

[0052] According to a favorite embodiment, at least three such sensors 6 are provided on the first casting line 2a:

- 20 - one first sensor 6 is positioned before the entrance of the cross-transfer area 35;
- one second sensor 6 is positioned soon after, the entrance of the cross-transfer area 35; and
- one third sensor 6 is positioned at the exit of the cross-
25 transfer area 35.

[0053] According to another embodiment represented in FIG. 2 and in FIGS. 5-7, at least a further sensor 7 is provided on the second casting line 2b, preferably connected to sensor
30 means 6 along the first casting line 2a and positioned at the

55910-71

17

exit of the cross-transfer area 35. Sensor 7 can determine when billets b2b have entered and effectively completed their insertion process within the cross-transfer area 35. The cooperation between sensors 6 and 7 can efficiently activate the bidirectional transfer means 30.

[0054] A production method according to the present invention comprises a first step of casting from a casting station 20 a multiplicity of strands on respective casting lines, wherein the multiplicity of casting lines comprise at least a first and a second casting line 2a, 2b, for producing respective elongated intermediate products.

[0055] Such elongated intermediate products are obtained by cutting the respective continuously cast strands.

[0056] On the first casting line 2a, a respective strand or respective elongated intermediate products b2a can be moved directly to feed a rolling mill 10; whereas on the second casting line 2b the respective elongated intermediate products b2b are moved in non-alignment with the rolling mill 10, up to a cross-transfer area 35.

[0057] The relative movement of the billets b2a, b2b on the two different casting lines 2a, 2b is preferably staggered so as to more easily create the necessary gaps for semi-endless functioning.

[0058] The above sensor means are then used as follows. Sensor means 6, 7 detect the presence and the position of strands or of elongated intermediate products, such as billets,

55910-71

18

and transmit a proportional signal to an overall automation control system. Such automation control system, based on the input received, accordingly activates the bidirectional transfer means 30.

5

[0059] The automation control system cooperates with the bidirectional transfer means 30 in the sense of determining, based on conditions detected by the sensors, the shifting of elongated intermediate products b2b into the first casting line 2a or towards a cooling bed 40 or, rather, the transitory stop thereof on casting line 2b.

[0060] The automation control system can advantageously take into account billet positions along first and second casting lines 2a, 2b; relative distances between billets b2a and billets b2b in their scattered movements; and speeds thereof, as well as, optionally, billets' dimensions.

[0061] In particular, sensor means 6, 7 allow the automation control system to automatically determine whether minimal conditions of non-interference between elongated intermediate products are satisfied on the first casting line 2a.

[0062] If such given minimal conditions of non-interference are satisfied, then the automation control system activates the bidirectional transfer means 30 to complement the elongated intermediate products which already are moving on the first casting line with additional elongated intermediate products b2b from the second casting line 2b by cross-transferring elongated intermediate products b2b from the second casting line 2b to the first casting line 2a. Whenever a sufficiently

55910-71

19

large gap between successive elongated intermediate products on the first line 2a is detected, then, a further elongated intermediate product b2b is shifted in a first direction, from the second casting line 2b to the first casting line 2a.

5 Analogously, if a multiplicity of casting lines are provided which comprises more than two casting lines as exemplified, further elongated intermediate products can be shifted from an nth line to the first casting line 2a aligned with the rolling mill 10.

10

[0063] In this case, elongated intermediate products b2b, cross-transferred from the second casting line 2b as exemplified in the intermediate passage of FIG. 2, are eventually fed to the rolling mill 10, to be rolled in series
15 with the elongated intermediate products which move along the first casting line 2a. This overall work-flow is schematically represented in the sequence of FIGS. 3A-3E.

[0064] FIG. 6 illustrates the completion of the cross-transfer
20 of a billet b2b by transfer means 30, wherein the subsequent repositioning of the lifting device 31 is also evident. In fact, the method according to the present invention comprises an intermediate step of repositioning the bidirectional transfer means 30 used for executing the steps of
25 - cross-transferring the elongated intermediate products from the second casting line 2b to the first casting line 2a; and
- transferring the elongated intermediate products b2b which have reached the cross-transfer area 35 on the second casting line 2b to a cooling bed 40. See sequence in FIGS. 4A-4E. The
30 intermediate repositioning step comprises bringing the bidirectional transfer means 30 back to a waiting position

55910-71

20

along the second casting line, in order to receive a further elongated intermediate product b2b entering the cross-transfer area 35 at casting speed or at an accelerated speed of up to 50 meters per minute.

5

[0065] A desired moving or shifting time for cross-transfer execution by transfer means 30 is of less than 20 seconds, preferably less than 15-12 seconds. Preferably, the whole execution cycle of the following operations is comprised within
10 such time ranges: acceleration of the billets b2b from their standstill, waiting position on line 2b to their cross-transfer speed; placement of the billets b2b on the first casting line 2a by the transfer means 30; and completion of the release of
15 billets b2b on the first casting line 2a, such that it may be accelerated towards the rolling mill entry.

[0066] Otherwise, if the result of sensor detection and elaboration by the control system is that such given minimal conditions of non-interference are not satisfied, the system
20 determines between two possible commands to be imparted to the bidirectional transfer means 30, in consideration of detection of subsequent, incoming elongated intermediate products b2b on said second casting line 2b.

[0067] These conditions may, for instance, be given also when
25 the first casting line 2a is functioning according to an endless operating mode and the strand continuously cast on line 2a is not cut into billets for a certain time span but is instead moved uncut to the rolling mill 10. In such conditions
30 and for the whole phase wherein an endless operating mode is adopted, no inter-billet gaps will be found on line 2a.

55910-71

21

[0068] As shown in FIG. 5, the bidirectional transfer means 30 can be instructed to keep the elongated intermediate products b2b which have reached said cross-transfer area 35 on the second casting line 2b within the cross-transfer area 35, until next minimal conditions of non-interference are verified on the first casting line 2a for concurrent transfer to the first casting line 2a as above explained.

[0069] If, instead, the control system determines that further keeping the elongated intermediate products b2b on the second casting line 2b within the cross-transfer area 35 will entail risk of collision or interference or cobbles due to the impending arrival of a billet or even of a still uncut strand from casting line 2b, the bidirectional transfer means 30 can be instructed to transfer and shift the elongated intermediate products b2b which have reached the cross-transfer area 35 on the second casting line 2b to a cooling bed 40, for subsequent sale as intermediate products.

20

[0070] This case is exemplified in the work-flow sequence of FIGS. 4A-4E and in FIG. 7. These billets which are let cool down on the cooling bed 40 can alternatively be used for later rolling by the rolling mill 10, particularly in times of non-availability of the casting station 20, instead of being directly sold as such.

[0071] In the apparatus according to the present invention, moreover, the automation control system can determine, based on input from the sensor means 6, 7, the variation of the casting speed of the strand of the first casting line 2a and/ or the

55910-71

22

variation of the casting speed of the strand of the second casting line 2b.

[0072] In addition, or in alternative, to the above mentioned casting speed variation for the cast strands, the automation control system of the present apparatus may also encompass the option of controlling acceleration and/or deceleration and/or stopping of elongated intermediate products b2a, b2b along the first and second cast lines 2a, 2b.

10

[0073] By controlled variation of the casting speed of the cast strands and/or of the moving speed of the billets on the respective casting lines, there is more easily regulated a sufficiently large gap between successive elongated intermediate products on the first line, so that effective activation of the bidirectional transferring means 30 for transferring elongated intermediate products b2b from the second casting line 2b in a first direction onto to the first casting line 2a is made possible.

20

[0074] The adjustment of the travelling speed of the billets on the casting lines makes it possible to proportionally increase the number of billets b2b which can be transferred to the first casting line 2a for hot rolling. Ideally, billets of all strands are accelerated after separating them from their strand by cutting, when operation is according to a semi-endless mode. Following this, the billets can be optionally decelerated to obtain a convenient relative distance between billets extremities, which can be approximately of 0,5-1,5 meters, which is usually called the intermediate billet gap.

30

55910-71

23

[0075] In particular, elongated intermediate products resulting from the casting process and moving along the first casting line 2a at casting speed may be accelerated, after being separated from the relative strand by cutting via cutting means 9, through the cross-transfer area 35 on their way to an induction heater 80 in FIG. 6, in order to create a big enough gap on the first casting line 2a to receive an elongated intermediate product b2b from the second casting line 2b. Cutting means 9 can for example be a shear tool or a torch cutter.

[0076] Analogously, elongated intermediate products b2b on the second casting line 2b can be accelerated after being separated from the respective strand by cutting via cutting means 9' towards and inside the cross transfer area 3b, in order to build up a distance gap from successive elongated intermediate products b2b and to synchronise with the abovementioned gap creation on the first casting line 2a, so that their shifting to the first casting line 2a is made possible.

20

[0077]

[0078] For example, for billets of a length of 12 meters, a convenient entrance inter-billet gap can be of about 14-15 meters; whereas, for billets of a length of 6 meters, a convenient entrance inter-billet gap can be of about 8-9 meters.

[0079] Also, for example, accelerated billets which move at 35 meters per minute, up to maximum 50 meters per minute, can be accelerated by at least 150 meters/min^2 , preferably by 180-300

55910-71

24

meters/min² and even more preferably by 500-1500 meters/min². The higher the speeds and accelerations, the more the flexibility to switch between endless and semi-endless operational modes is enhanced.

5

[0080] By varying the relative casting speed of the strand casting process along respective casting lines 2a, 2b; and/or by varying the speed of the elongated intermediate products resulting from casting and moving along the first casting line 10 2a; and/or by varying the speed of the elongated intermediate products b2b resulting from casting and moving along the second casting line 2b, a convenient staggering of the relative movement of elongate intermediate products b2a, b2b on different casting lines can be achieved.

15

[0081] Thus, cross-transferring of elongated intermediate products b2b from the second casting line 2b to the first casting line 2a is made easier and safer in that less prone to cobbles.

20

[0082] Similarly, the sensor means 6, 7 can control the waiting time during which elongated intermediate products b2b are kept idle within the cross-transfer area 35 along the second casting line 2b. The duration of the above waiting time can be 25 advantageously coordinated with the creation of a sufficient gap on the first casting line 2a, as above explained, allowing for shifting of such elongated intermediate products b2b from the second casting line 2b to the first casting line 2a.

30

[0083] As above mentioned, the apparatus according to the present invention preferably comprises heating means 80, in

55910-71

25

FIGS. 4A, 4E, 5, 6 and 7, for the elongated intermediate products. Such heating means is advantageously positioned separate from the bidirectional transfer means 30 along the production line, in particular preferably downstream from the plant section where the bidirectional transfer means 30 is located. The heating means 80 is preferably an inductive heater, but a gas furnace may be possible, although it is less preferred. In any event, the design of the apparatus 100 according to the present invention is such that no long tunnel or excessively long furnace is interposed between billet shearing and entrance to the rolling mill 10.

[0084] The automation control system of the apparatus according to the present invention can control - e.g. by advantageously using sensors 6, 7 in combination with a billet stopping system the deceleration of the previously accelerated elongated intermediate products in correspondence of the induction heater 80 on the first casting line 2a, so that these products reach an optimal temperature for subsequent hot rolling by spending the optimal amount of time passing through the induction heater 80. The power of the induction heater 80 is anyhow preferably set and dimensioned to cope with the additional billets b2b which are transferred to the first casting line 2a. An optimum compromise needs to be therefore achieved between the reduction of speed through the induction heater 80 and the heating power developed by the induction heater itself. At any rate, the apparatus 100 according to the present invention minimizes heat loss, also thanks to the compact structural solution presented in the following.

30

55910-71

26

[0085] The apparatus 100 according to the present invention preferably comprises a first shear tool 9 in FIG. 2 for the elongated intermediate products which are cast on the first casting line 2a. As explained above, the first casting line 2a can also function in an endless operating mode, in connection with which the continuously cast strand on line 2a is not cut. Such a shear tool 9 is preferably positioned just after the casting line's region corresponding to the so called maximum solidification length (calculated in accordance with casting section and maximum speed/throughput). The shearing time can be advantageously less than a second, whereas other cutting techniques such as torch cutting normally require 15-60 seconds, depending mainly on billet cross section and on torch output power. Evidently, such gain in time causes less heat loss of the billets while travelling along the casting lines, and proportionally less heat output required from induction heater 80. The apparatus 100 according to the present invention also comprises a second shear tool 9' in FIG. 2 for cutting the strand continuously cast on line 2b into elongated intermediate products b2b.

[0086] The structure of the apparatus 100 according to the present invention preferably has the distance between the first shear tool 9 and the entrance to the heating means 80 is less than 2.4 times the rated maximum length of the elongated intermediate products, and preferably less than 2 times the rated length of the elongated intermediate products. This construction measure further enhances the energy saving characteristics of the apparatus 100 according to the present invention. For example, an apparatus according to the present invention would make an arrangement of a plant for production

55910-71

27

and rolling of billets measuring 18 meters possible, wherein the overall distance between the shear tool 9 and the end of the cross-transfer area 35 is only about 34 meters; or the overall distance between shear tool 9 and entry to the heating means 80 is only about 37 meters. This would be achieved while still having good further safety/robustness margins, for instance taking into account the vacant space between the head or forward extremity of the first incoming billet b2a on line 2a in FIG. 2 and the first sensor 6.

10

[0087] In case there is no inductive heater installed, the distance between the first cutting tool after final solidification on the first billet strand 2a up to entry into the first rolling stand can even be made less than 2.7 times the maximum rated billet length, preferably less than 2.4 times the maximum rated billet length, when considering a semi-endless operation mode. This configuration can still allow space for a snap shear and/or a descaling unit placed between the end of the cross-transfer area 35 and the first rolling stand 5.

20

[0088] According to an embodiment of the apparatus 100 according to the present invention, moving means for transferring elongated intermediate products b2a of the first casting line 2a to an emergency bed 4 in FIG. 1 can be also provided.

25

[0089] Such an emergency cooling bed 4 is preferably positioned substantially opposite, with respect to the casting line direction, to the cooling bed 40 for the elongate intermediate products b2b from the second casting line 2b. The emergency

30

55910-71

28

cooling bed 4 as above defined might be useful, for instance, in case a cobble condition occurs in the rolling mill 10; or if quality issues arise and the billets moving along the first casting line 2a are not suitable for immediate rolling.

5 Preferably, up to 6 or 10 billets can be shifted aside on the emergency cooling bed 4 from the first casting line 2a, for sale or for later back-shifting and semi-endless rolling.

[0090] Such moving means for transferring elongated
10 intermediate products b2a of the first casting line 2a to an emergency bed 4 can be separate from the bidirectional transfer means 30. The decoupling of the above moving means from the bidirectional transfer means 30 can be advantageous in case the transfer means are faced with high operational demand in
15 transferring elongated intermediate products b2b.

[0091] Alternatively, such further moving means can be comprised in bidirectional transfer means 30 or therewith combined, for instance cooperating with said lifting device 31.

20

[0092] The apparatus 100 according to the present invention, and the method of operating such an apparatus, effectively achieve maximization of rolling throughput by:

- optimizing the entry sequence of additional billets to be
25 finally rolled, when functioning according to a semi-endless operation mode;
- allowing seamless, prompt switching to an endless operation mode on the line which is directly linked to the rolling mill;

55910-71

29

- concurrently, rationalizing intermediate billet production and storing, when dictated by production requirements or when critical conditions arise.

Moreover, relative to the semi-endless operation mode, the
5 present invention guarantees minimization of heat loss along the casting lines on the way to the billet heating means; and a minimization of inter-billet gaps, in total safety and preventing billet collisions/interferences or cobbles.

CLAIMS:

1. Apparatus for production of elongated metal products, said apparatus comprising:

- a rolling mill comprising at least one rolling stand,
- a casting station comprising at least a first casting line and at least a second casting line, each line being operable to produce respective continuous strands and elongated intermediate products, wherein:

- the first casting line is directly aligned with the rolling mill, said first casting line being configured to feed the rolling mill with continuous casting strands or cast elongated intermediate products, and

- the second casting line is not aligned with the rolling mill;

- said apparatus further comprises:

- bidirectional transfer means for transferring elongated intermediate products of the second casting line in a first direction from said second casting line to said first casting line to align said elongated intermediate product with the rolling mill;

- said bidirectional transfer means is positioned over one cross-transfer area

- wherein:

- said bidirectional transfer means are foreseen for transferring elongated intermediate products of the second casting line in a second direction from said at least second casting line to a cooling bed;

- the components of said bidirectional transfer means are substantially at a same level along said first and said second casting lines;

- an automation control system comprising sensor means at least along said first casting line cooperating with said bidirectional transfer means;

- at least three sensors along the first casting line are provided as said sensor means, whereas

· one first sensor of said at least three sensors is positioned within a range of 1-6 meters upstream of an entrance to the cross-transfer area;

· one second sensor is positioned within the cross-transfer area soon after the entrance of the cross-transfer area;

· one third sensor is positioned within the cross-transfer area at an exit of the cross-transfer area;

- said bidirectional transfer means comprises a lifting device for carrying elongated intermediate products, cooperating with

· first moving means, for transferring said elongated intermediate products of the second casting line

· in the first direction; and second moving means for transferring said elongated intermediate products of the second casting line in the second direction;

· wherein said lifting device, first moving means and second moving means are positioned over the cross-transfer area substantially spatially at the same level along said first and second casting lines.

2. Apparatus according to claim 1, wherein the elongated metal products are bars, rods or the like.

3. Apparatus according to claim 1, wherein the elongated intermediate products are billets.

4. Apparatus according to any one of claims 1 to 3, comprising sensor means along said second casting line, connected to said sensor means along said first casting line.

5. Apparatus according to claim 4, wherein said automation control system determines, based on input from said sensor means, one or more of:

a variation of a first casting speed from said casting station on said first casting line;

a variation of a second casting speed from said casting station on said second casting line;

acceleration of elongated intermediate products along said first casting line or said second casting line or said first casting line and second cast line;

deceleration of elongated intermediate products along said first casting line or said second casting line or said first casting line and second cast line; and

stopping of elongated intermediate products along said first casting line or said second casting line or said first casting line and second cast line.

6. Apparatus according to any one of claims 1 to 5, comprising heating means for said elongated intermediate products, said heating means being positioned separate from said bidirectional transfer means and downstream from said bidirectional transfer means.

7. Apparatus according to claim 6, comprising a first shear tool for said elongated intermediate products on said first casting line, wherein a distance between said first shear tool

and an entrance to said heating means is less than 2.4 times a rated maximum length of said elongated intermediate products.

8. Apparatus according to claim 7, wherein the distance between said first shear tool and the entrance to said heating means is less than 2 times the rated maximum length of said elongated intermediate products.

9. Method for producing elongated metal products by operating the apparatus according to any one of claims 1 to 8, comprising the steps of:

- casting from a casting station a multiplicity of casting strands on respective casting lines, said multiplicity of casting lines comprising at least a first and a second casting line, for producing elongated intermediate products, wherein:

- on said first casting line, a respective casting strand is moved to directly feed a rolling mill or respective elongated intermediate products are moved directly to feed the rolling mill;

- whereas on said second casting line, respective elongated intermediate products are moved in non-alignment with said rolling mill up to a cross-transfer area;

- wherein in that said method further comprises the steps of:

- detecting by sensor means whether given minimal conditions of non-interference between elongated intermediate products are satisfied on the first casting line;

- if such given minimal conditions of non-interference are satisfied, complementing the elongated intermediate products which move on said first casting line with elongated intermediate products from said second casting line by cross-transferring within the cross-transfer area said elongated

intermediate products from said second casting line to said first casting line; and finally

- feeding said elongated intermediate products which are cross-transferred from said second casting line to said rolling mill, to be rolled in series with said elongated intermediate products on said first casting line; whereas

- if such given minimal conditions of non-interference are not satisfied, automatically determining, in consideration of detection of subsequent, incoming elongated intermediate products on said second casting line, between the steps of:

- keeping the elongated intermediate products which have reached said cross-transfer area on said second casting line within said cross-transfer area, until next minimal conditions of non-interference are verified on said first casting line for transfer to said first casting line and subsequent rolling; or - transferring the elongated intermediate products which have reached said cross-transfer area on said second casting line to a cooling bed, for subsequent sale as intermediate products.

10. Method according to claim 9, wherein the elongated metal products are bars, rods or the like.

11. Method according to any one of claims 9 or 10, wherein the step of cross-transferring said elongated intermediate products from said second casting line to said first casting line; and the step of transferring the elongated intermediate products which have reached said cross-transfer area on said second casting line to a cooling bed, are executed substantially spatially at a same level along said first and second casting lines, within said cross-transfer area.

12. Method according to any one of claims 9 to 11, comprising an intermediate step of repositioning the bidirectional transfer means used for executing the steps of

- cross-transferring said elongated intermediate products from said second casting line to said first casting line; and
- transferring the elongated intermediate products which have reached said cross-transfer area on said second casting line to a cooling bed;

said intermediate repositioning step comprising bringing said bidirectional transfer means back to a waiting position along said second casting line, in order to receive a further elongated intermediate product entering the cross-transfer area.

13. Method according to any one of claims 11 to 12, comprising a further step of heating the intermediate products moving along said first casting line, said heating step following and being separate from said cross-transferring step of elongated intermediate products from said second casting line to said first casting line.

14. Method according to any one of claims 9 to 13, comprising the step of varying a casting speed of the strand on said first casting line and/or a casting speed of the strand on said second casting line.

15. Method according to any one of claims 9 to 14, comprising the step of varying a speed of said elongate intermediate products resulting from casting and moving along said first casting line; and/or the step of varying a speed of said elongate intermediate products resulting from casting and moving along said second casting line.

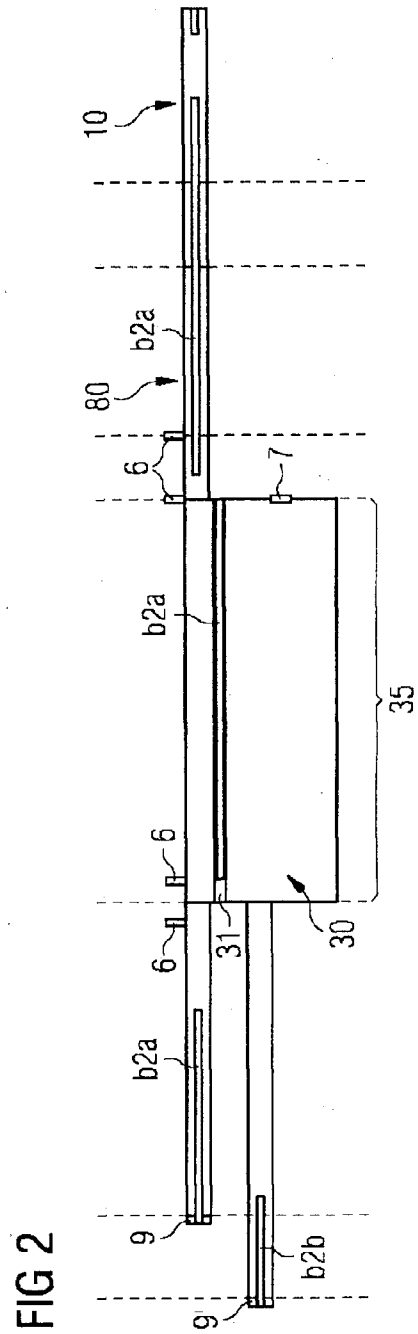
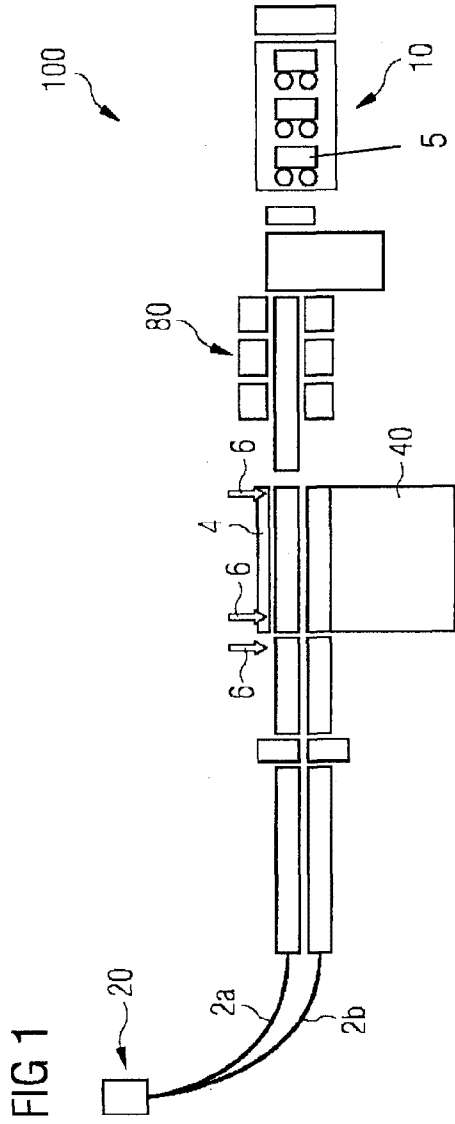

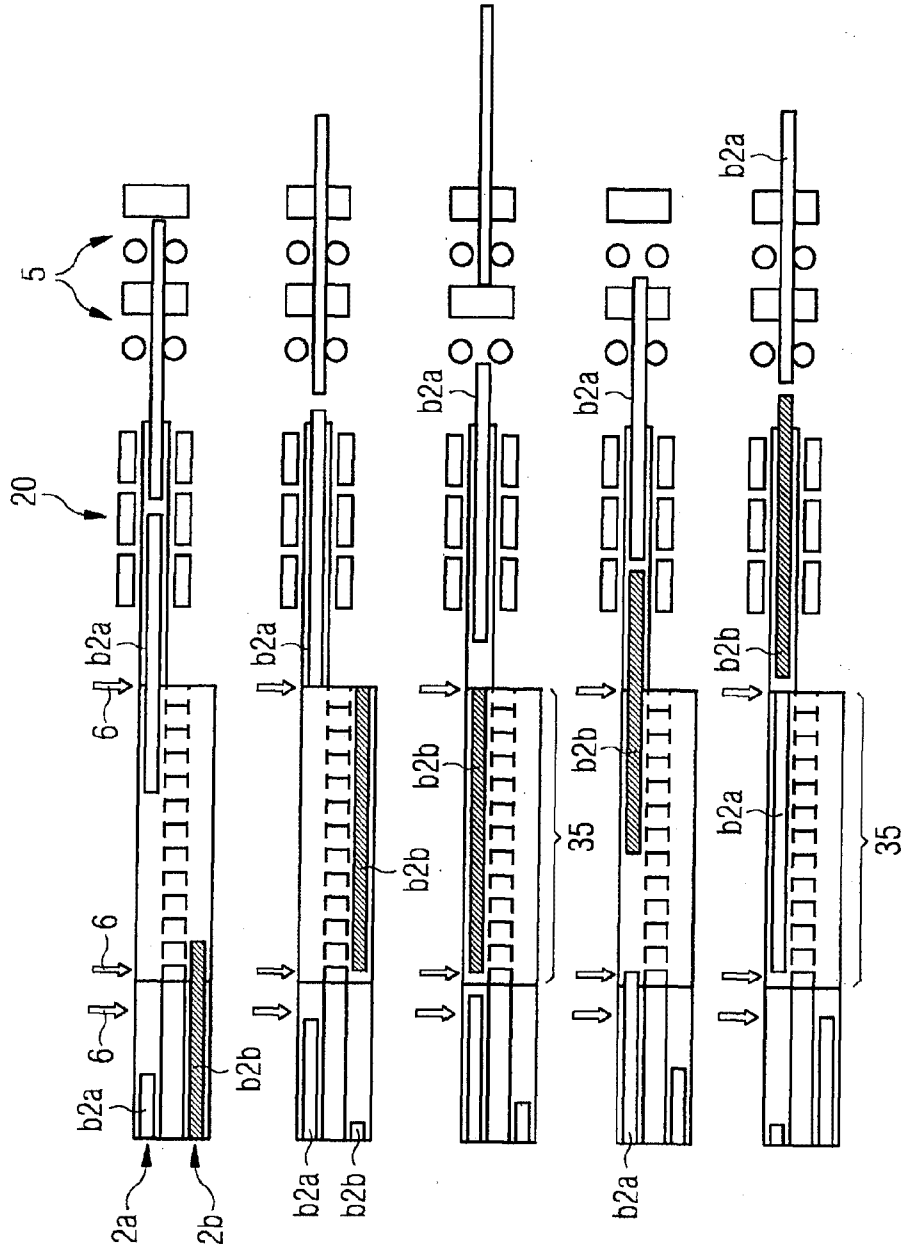

FIG. 3A

FIG. 3B

FIG. 3C

FIG. 3D

FIG. 3E

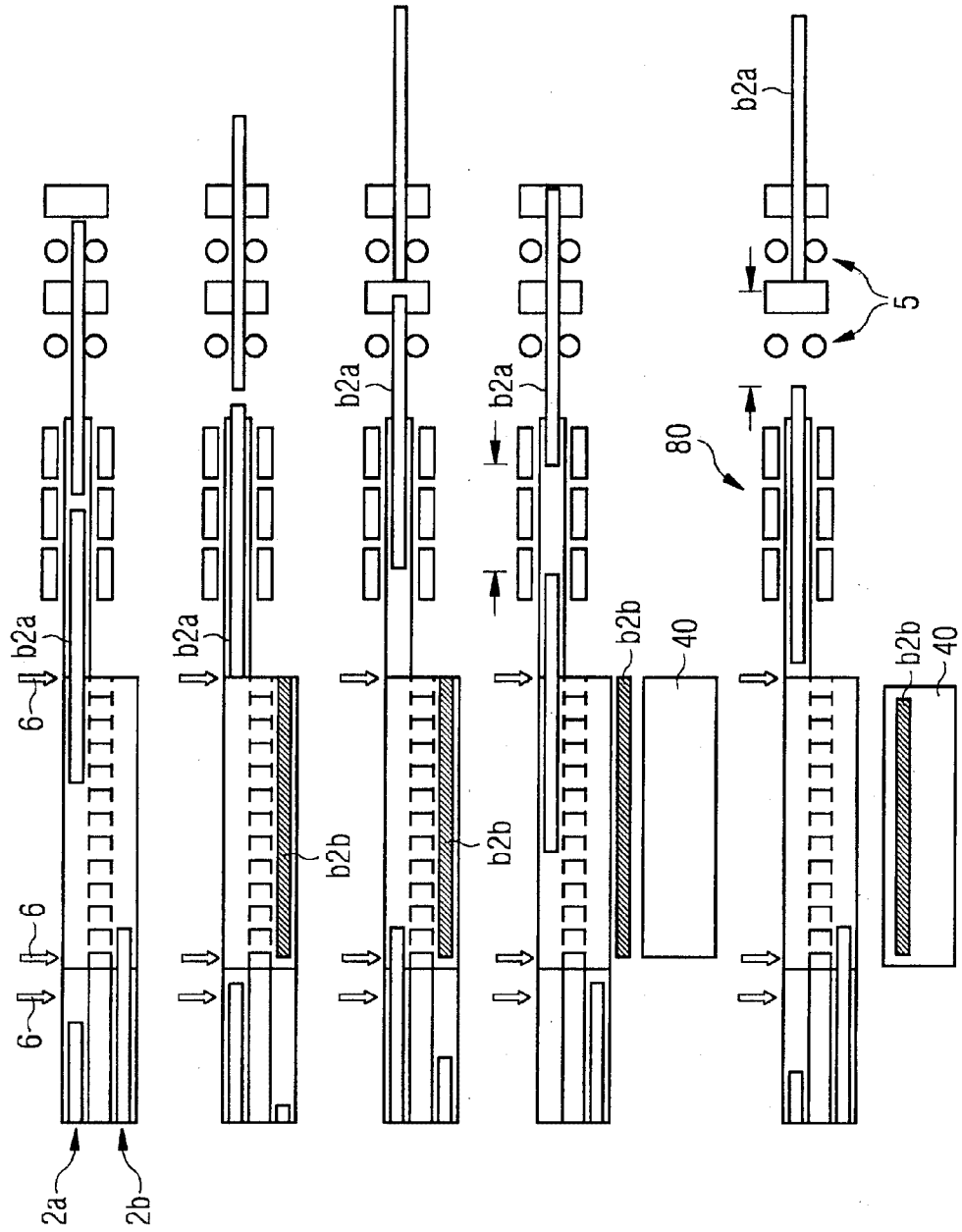

FIG. 4A

FIG. 4B

FIG. 4C

FIG. 4D

FIG. 4E

FIG 5

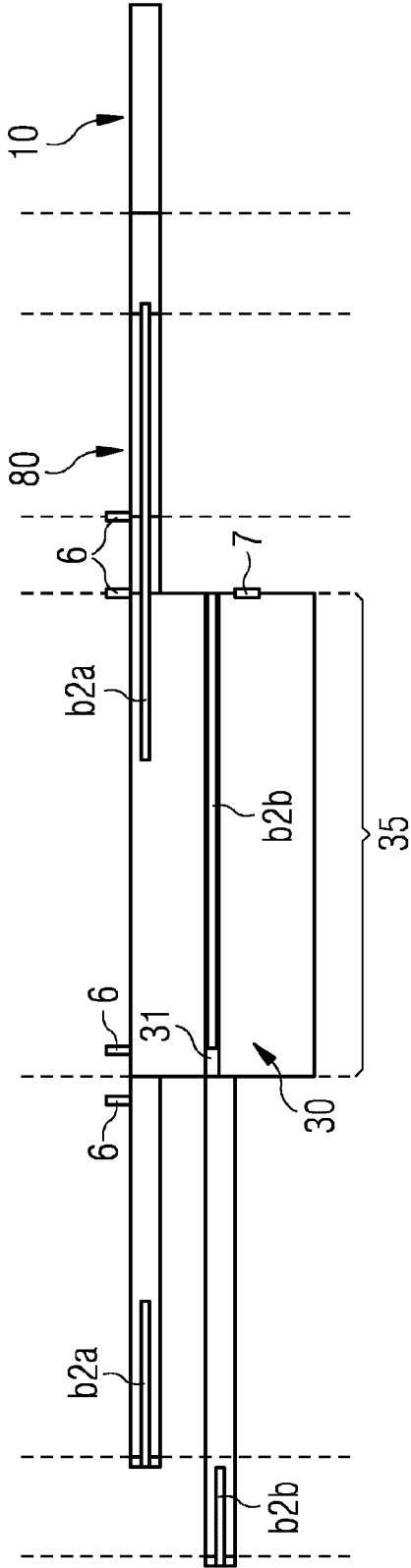

FIG 6

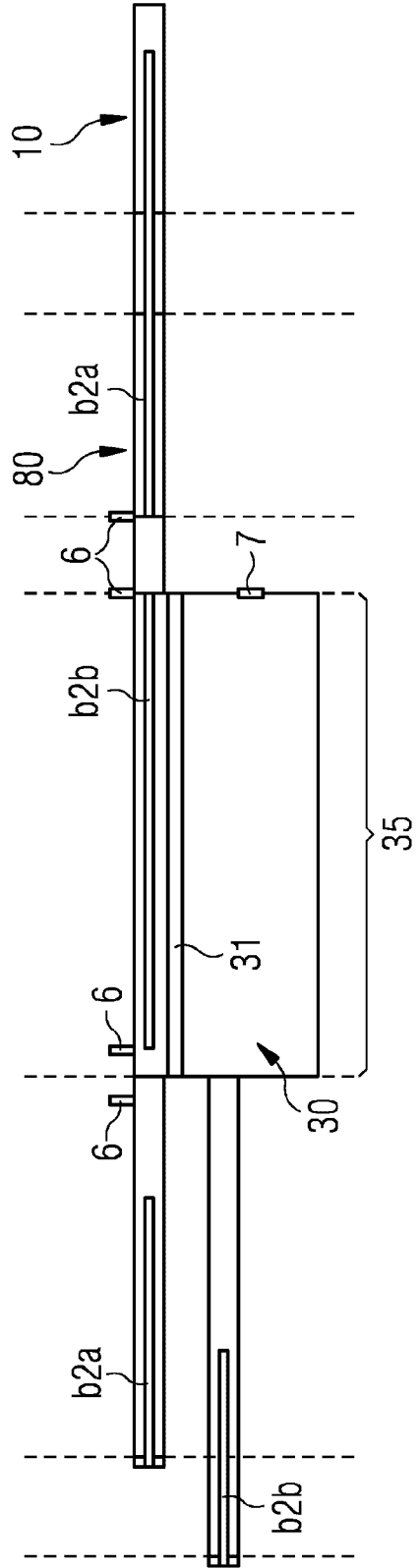

FIG 7

