

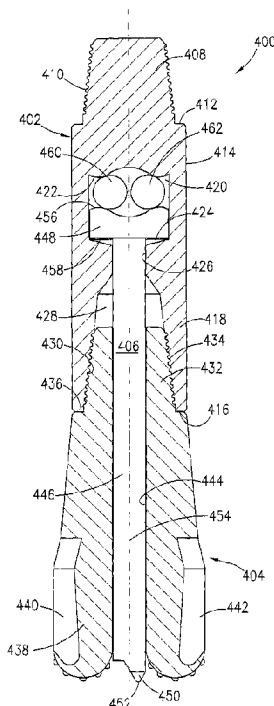

(86) **Date de dépôt PCT/PCT Filing Date:** 2017/01/13
 (87) **Date publication PCT/PCT Publication Date:** 2017/08/03
 (45) **Date de délivrance/Issue Date:** 2020/07/21
 (85) **Entrée phase nationale/National Entry:** 2018/05/22
 (86) **N° demande PCT/PCT Application No.:** US 2017/013393
 (87) **N° publication PCT/PCT Publication No.:** 2017/131969
 (30) **Priorité/Priority:** 2016/01/27 (US15/008,071)

(51) **Cl.Int./Int.Cl. E21B 10/26** (2006.01),
E21B 10/28 (2006.01), **E21B 10/40** (2006.01),
E21B 17/07 (2006.01), **E21B 6/02** (2006.01),
F16H 25/12 (2006.01), **F16H 25/22** (2006.01)
 (72) **Inventeurs/Inventors:**
 VON GYNZ-REKOWSKI, GUNTHER HH, US;
 WILLIAMS, MICHAEL V., US
 (73) **Propriétaire/Owner:**
 ASHMIN HOLDING LLC, US
 (74) **Agent:** RICHES, MCKENZIE & HERBERT LLP

(54) **Titre : APPAREIL ET PROCEDE DE FORAGE**
 (54) **Title: BORING APPARATUS AND METHOD**



(57) **Abrégé/Abstract:**

A boring apparatus includes an upper member and a bit body configured to rotate relative to a pilot bit. A first end of the upper member is connected to a workstring. An inner cavity of the upper member includes a first radial cam surface. A first end of the bit body is connected to a second end of the upper member such that the bit body rotates with the upper member. A second end of the bit body includes a working face. The pilot bit includes a first end disposed within the inner cavity of the upper member, and includes a second radial cam surface configured to cooperate with the first radial cam surface to deliver a hammering force. The pilot bit extends through a central bore of the bit body, and includes an engaging surface on its second end configured to engage a formation surrounding the wellbore.

(12) INTERNATIONAL APPLICATION PUBLISHED UNDER THE PATENT COOPERATION TREATY (PCT)

(19) World Intellectual Property Organization
International Bureau



(10) International Publication Number
WO 2017/131969 A1

(43) International Publication Date
3 August 2017 (03.08.2017)

(51) International Patent Classification:

E21B 10/26 (2006.01) *E21B 6/02* (2006.01)
E21B 10/28 (2006.01) *F16H 25/12* (2006.01)
E21B 10/40 (2006.01) *F16H 25/22* (2006.01)
E21B 17/07 (2006.01)

(72) Inventors: **VON GYNZ-REKOWSKI, Gunther, HH**; 100 Hwy. I-45 North, Suite 610, Conroe, TX 77301 (US).
WILLIAMS, Michael, V.; 8458 Coral Cove Pass Lane, Conroe, TX 77304 (US).

(21) International Application Number:

PCT/US2017/013393

(74) Agents: **WADDELL, Robert L.** et al.; 600 Jefferson Street, Suite 1600, Lafayette, LA 70501 (US).

(22) International Filing Date:

13 January 2017 (13.01.2017)

(81) Designated States (unless otherwise indicated, for every kind of national protection available): AE, AG, AL, AM, AO, AT, AU, AZ, BA, BB, BG, BH, BN, BR, BW, BY, BZ, CA, CH, CL, CN, CO, CR, CU, CZ, DE, DJ, DK, DM, DO, DZ, EC, EE, EG, ES, FI, GB, GD, GE, GH, GM, GT, HN, HR, HU, ID, IL, IN, IR, IS, JP, KE, KG, KH, KN, KP, KR, KW, KZ, LA, LC, LK, LR, LS, LU, LY, MA, MD, ME, MG, MK, MN, MW, MX, MY, MZ, NA, NG, NI, NO, NZ, OM, PA, PE, PG, PH, PL, PT, QA, RO, RS, RU, RW, SA, SC, SD, SE, SG, SK, SL, SM, ST, SV, SY, TH, TJ, TM, TN, TR, TT, TZ, UA, UG, US, UZ, VC, VN, ZA, ZM, ZW.

(25) Filing Language:

English

(26) Publication Language:

English

(30) Priority Data:

15/008,071 27 January 2016 (27.01.2016) US

(71) Applicant: **ASHMIN HOLDING LLC** [US/US]; 100 Hwy. I-45 North, Suite 610, Conroe, TX 77301 (US).

[Continued on next page]

(54) Title: BORING APPARATUS AND METHOD

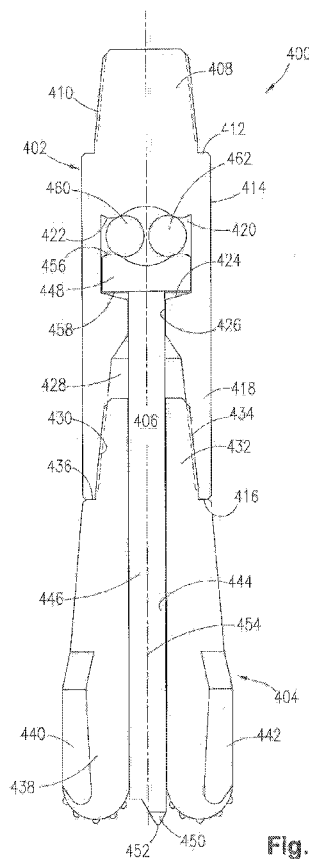

(57) Abstract: A boring apparatus includes an upper member and a bit body configured to rotate relative to a pilot bit. A first end of the upper member is connected to a workstring. An inner cavity of the upper member includes a first radial cam surface. A first end of the bit body is connected to a second end of the upper member such that the bit body rotates with the upper member. A second end of the bit body includes a working face. The pilot bit includes a first end disposed within the inner cavity of the upper member, and includes a second radial cam surface configured to cooperate with the first radial cam surface to deliver a hammering force. The pilot bit extends through a central bore of the bit body, and includes an engaging surface on its second end configured to engage a formation surrounding the wellbore.

Fig. 17

WO 2017/131969 A1

WO 2017/131969 A1 

(84) Designated States (*unless otherwise indicated, for every kind of regional protection available*): ARIPO (BW, GH, GM, KE, LR, LS, MW, MZ, NA, RW, SD, SL, ST, SZ, TZ, UG, ZM, ZW), Eurasian (AM, AZ, BY, KG, KZ, RU, TJ, TM), European (AL, AT, BE, BG, CH, CY, CZ, DE, DK, EE, ES, FI, FR, GB, GR, HR, HU, IE, IS, IT, LT, LU, LV, MC, MK, MT, NL, NO, PL, PT, RO, RS, SE, SI, SK, SM, TR), OAPI (BF, BJ, CF, CG, CI, CM, GA, GN, GQ, GW, KM, ML, MR, NE, SN, TD, TG).

Declarations under Rule 4.17:

- *as to applicant's entitlement to apply for and be granted a patent (Rule 4.17(ii))*
- *as to the applicant's entitlement to claim the priority of the earlier application (Rule 4.17(iii))*

Published:

- *with international search report (Art. 21(3))*

BORING APPARATUS AND METHOD

CROSS-REFERENCE TO RELATED APPLICATIONS

[0001] This application claims priority to U.S. Patent Application No. 15/008,071, filed on January 27, 2016.

5

BACKGROUND OF THE INVENTION

[0002] This disclosure relates to a boring apparatus and method. More particularly, but not by way of limitation, this invention relates to a drill bit and a method of boring wells.

[0003] Drill bits have been used for boring subterranean wells. In the boring of a wellbore, the operator seeks to drill the well efficiently, safely, and economically. Drill bits are required to drill straight wells, deviated wells, horizontal wells, multilaterals, etc. Various drill bits have been proposed through the years, including roller-cone bits and polycrystalline diamond compact bits.

SUMMARY OF THE INVENTION

15 **[0004]** In one embodiment, an apparatus is disclosed that includes a rotating segment having a first radial surface with a first circumferential profile; a non-rotating segment having a second radial surface with a second circumferential profile; a housing disposed around the first and second radial surfaces; and one or more rolling elements disposed between and in contact with the first and second radial surfaces for transferring
20 the non-rotating segment in an axial direction upon rotation of the rotating segment. Each rolling element moves 360 degrees along a circular path relative to the first radial surface and 360 degrees along a circular path relative to the second radial surface. The rotating segment rotates more than 360 degrees relative to the non-rotating segment. The first circumferential profile may include the tapered section, which may include an undulating
25 waveform profile. The second circumferential profile may include the tapered section, which may include an undulating waveform profile. Each of the rolling elements may include a spherical outer surface. In one embodiment, the apparatus may include two rolling elements in contact with one another, and with each rolling element having a diameter that is equal to one-half of an inner diameter of

WO 2017/131969

PCT/US2017/013393

the housing. In another embodiment, the apparatus may include three or more rolling elements, with each rolling element in contact with two adjacent rolling elements. In yet another embodiment, the apparatus may include two or more rolling elements and a guide member, which is disposed between the first and second radial surfaces for retaining the rolling elements in a fixed position relative to one another.

[0005] In another embodiment, an apparatus is disclosed that includes a first rotating segment having a first radial surface with a first circumferential profile; a second rotating segment having a second radial surface with a second circumferential profile; a housing disposed around the first and second radial surfaces; and one or more rolling elements disposed between and in contact with the first and second radial surfaces for transferring the second rotating segment in an axial direction upon rotation of the first rotating segment. The second rotating segment rotates at different rotational rate than the first rotating segment. Alternatively, first and second rotating segments rotate in opposite directions. Each rolling element moves 360 degrees along a circular path relative to the first radial surface and 360 degrees along a circular path relative to the second radial surface. The first rotating segment rotates more than 360 degrees relative to the second rotating segment. The first circumferential profile may include the tapered section, which may include an undulating waveform profile. The second circumferential profile may include the tapered section, which may include an undulating waveform profile. Each of the rolling elements may include a spherical outer surface. In one embodiment, the apparatus may include two rolling elements in contact with one another, and with each rolling element having a diameter that is equal to one-half of an inner diameter of the housing. In another embodiment, the apparatus may include three or more rolling elements, with each rolling element in contact with two adjacent rolling elements. In yet another embodiment, the apparatus may include two or more rolling elements and a guide member, which is disposed between the first and second radial surfaces for retaining the rolling elements in a fixed position relative to one another.

[0006] In another embodiment, an apparatus for boring a well is disclosed, with the apparatus being connected to a workstring. The apparatus includes a bit body having a first end, an inner cavity, and second end, with the first end connected to the workstring that is configured to deliver a rotational force to the bit body. The inner cavity contains a profile having a first radial cam surface. The second end of the bit body includes a working face containing a cutting member. The apparatus also includes a pilot bit rotatively connected

WO 2017/131969

PCT/US2017/013393

within the inner cavity of the bit body. The pilot bit extends from the working face. The pilot bit includes a first end and a second end. The first end of the pilot bit has a second radial cam surface operatively configured to cooperate with the first radial cam surface to deliver a hammering force. The second end of the pilot bit includes an engaging surface
5 configured to engage a formation surrounding the wellbore. The bit body rotates at a different rate than the pilot bit. The first radial cam surface may include an inclined portion and an upstanding portion. The second radial cam surface may include an inclined portion and an upstanding portion. The engaging surface may include an eccentric conical surface. Alternatively, the engaging surface may include a chiseled surface. The workstring may
10 contain a mud motor for delivering rotational force. The apparatus may further include a retainer operatively associated with the pilot bit for retaining the pilot bit within the inner cavity. The workstring may be a tubular drill string or a coiled tubing string. The apparatus may further include one or more rolling elements disposed between and in contact with the first and second radial cam surfaces. Each of the rolling elements may be a spherical outer
15 surface. The apparatus may include two rolling elements in contact with one another, where a diameter of each of the rolling elements is equal to one-half of an inner diameter of the inner cavity. The apparatus may include three or more rolling elements, with each of the rolling elements in contact with two adjacent rolling elements. The apparatus may include two or more rolling elements and a guide member, which is disposed between the first and
20 second radial cam surfaces for retaining the rolling elements in a fixed position relative to one another.

[0007] A method of boring a wellbore is also disclosed. The method includes providing a bit apparatus within the wellbore, with the bit apparatus comprising: a bit body having a first end, an inner cavity, and second end, with the first end connected to the
25 workstring that is configured to deliver a rotational force to the bit body; the inner cavity containing a profile having a first radial cam surface; the second end including a working face containing a cutting member; the apparatus also including a protuberance rotatively connected within the inner cavity of the bit body and extending from the working face; the protuberance including a first end and a second end, with the first end having a second radial
30 cam surface and the second end having an engaging surface. The method further includes lowering the bit apparatus into the wellbore, contacting the cutting member of the working face with a reservoir interface, rotating the bit body relative to the protuberance, engaging the engaging surface of the protuberance with the reservoir interface in the wellbore, and

WO 2017/131969

PCT/US2017/013393

impacting the second radial cam surface with the first radial cam surface so that a percussive force is delivered to the cutting member and the engaging surface while drilling the wellbore. In one embodiment, the first radial cam surface comprises an inclined portion and an upstanding portion, and the second radial cam surface comprises an inclined portion and an upstanding portion. The workstring may contain a mud motor for delivering a rotational force. The workstring may be a tubular drill string, production string, or a coiled tubing string. Additionally, the engaging surface may be an eccentric conical surface or a chiseled surface. The protuberance may be rotated due to frictional forces associated with the rotation of the bit body, with a rotation rate of the protuberance being different than a rotation rate of the bit body. The bit apparatus may also include one or more rolling elements disposed between and in contact with the first and second radial cam surfaces, and the method may include impacting the second radial cam surface with the first radial cam surface through the rolling elements. Each of the rolling elements may include a spherical outer surface.

[0008] In yet another embodiment, an apparatus for boring a well is disclosed, with the apparatus being connected to a workstring. The apparatus includes a bit body having a first end, an inner cavity, and second end, with the first end connected to the workstring that is configured to deliver a rotational force to the bit body. The inner cavity contains a profile having a hammer. The second end of the bit body includes a working face containing a plurality of cutting members. The apparatus also includes a protuberance rotatively connected within the inner cavity of the bit body. The protuberance extends from the working face. The protuberance includes a first end and a second end. The first end of the protuberance contains an anvil. The second end of the protuberance contains an engaging surface configured to engage a formation surrounding the wellbore. The hammer is operatively configured to deliver a hammering force to the anvil. The bit body rotates relative to the protuberance. The workstring may contain a mud motor for delivering rotational force. The hammer may include an inclined portion and an upstanding portion. The anvil may include an inclined portion and an upstanding portion. Alternatively, the profile of the inner cavity further includes a first radial cam surface, and the first end of the protuberance further includes a second radial cam surface configured to cooperate with the first radial cam surface. The apparatus may further include a retainer operatively associated with the protuberance to retain the protuberance within the inner cavity. The engaging surface may include an eccentric conical surface or a chiseled surface. The workstring may be a tubular drill string or a coiled tubing string. The protuberance may rotate at a different

WO 2017/131969

PCT/US2017/013393

rotational rate than the bit body. The apparatus may further include one or more rolling elements disposed between and in contact with the hammer and the anvil. Each of the rolling elements may be a spherical outer surface. The apparatus may include two rolling elements in contact with one another, where a diameter of each of the rolling elements is equal to one-half of an inner diameter of the inner cavity. The apparatus may include three or more rolling elements, with each of the rolling elements in contact with two adjacent rolling elements. The apparatus may include two or more rolling elements and a guide member, which is disposed between the hammer and the anvil for retaining the rolling elements in a fixed position relative to one another.

10 [0009] In another alternate embodiment, an apparatus for boring a wellbore includes an upper member, a bit body, and a pilot bit. The upper member includes a first end, an inner cavity, and a second end. The first end is connected to a workstring that is concentrically positioned in the wellbore. The workstring is configured to deliver a rotational force to the upper member. The inner cavity contains a profile having a first radial cam surface. The bit

15 body includes a first end, a second end, and a central bore extending from the first end to the second end. The first end of the bit body is operatively connected to the second end of the upper member, with the bit body configured to rotate with a rotation of the upper member. The second end of the bit body includes a working face containing a cutting member. The pilot bit is rotatively connected within the inner cavity of the upper member and extends

20 through the central bore of the bit body beyond the working face of the bit body. The pilot bit includes a first end and a second end. The first end includes a second radial cam surface operatively configured to cooperate with the first radial cam surface to deliver a hammering force. The second end of the pilot bit includes an engaging surface configured to engage a formation surrounding the wellbore. The upper member and the bit body rotate relative to the

25 pilot bit. The first radial cam surface and the second radial cam surface may each include an inclined portion and an upstanding portion. The engaging surface of the pilot bit may include an eccentric conical surface or a chiseled surface. The apparatus may further include a retainer operatively associated with the pilot bit for retaining the pilot bit within the inner cavity. The apparatus may further include one or more rolling elements disposed between

30 and in contact with the first radial cam surface and the second radial cam surface. Each of the rolling elements may include a spherical outer surface. The apparatus may include two rolling elements in contact with one another, with a diameter of each of the rolling elements being approximately equal to one-half of an inner diameter of the inner cavity. Alternatively,

WO 2017/131969

PCT/US2017/013393

the apparatus may include three or more rolling elements, with each of the rolling elements in contact with two adjacent rolling elements. In another alternative, the apparatus may include two or more rolling elements and a guide member, with the guide member disposed between the first and second radial cam surfaces for retaining the rolling elements in a fixed position relative to one another. The workstring may contain a mud motor for delivering the rotational force. The workstring may be a tubular drill string or a coiled tubing string.

[0010] In yet another alternate embodiment, an apparatus for boring a wellbore includes an upper member, a bit body, and a protuberance. The upper member includes a first end, an inner cavity, and a second end. The first end is connected to a workstring that is concentrically positioned within a wellbore. The workstring is configured to deliver a rotational force to the upper member. The inner cavity contains a profile having a hammer. The bit body includes a first end, a second end, and a central bore extending from the first end to the second end. The first end of the bit body is operatively connected to the second end of the upper member. The bit body is configured to rotate with a rotation of the upper member. The second end of the bit body includes a working face containing a plurality of cutting member. The protuberance is rotatively connected within the inner cavity of the upper member and extends through the central bore of the bit body beyond the working face of the bit body. The protuberance includes a first end and a second end. The first end includes an anvil and the second end includes an engaging surface configured to engage a formation surrounding the wellbore. The hammer of the upper member is operatively configured to deliver a hammering force to the anvil of the protuberance. The upper member and the bit body rotate relative to the pilot bit. The hammer and the anvil may each include an inclined portion and an upstanding portion. The engaging surface of the protuberance may include an eccentric conical surface or a chiseled surface. The profile of the inner cavity of the upper member may further include a first radial cam surface, and the first end of the protuberance may further include a second radial cam surface configured to cooperate with the first radial cam surface. The apparatus may further include one or more rolling elements disposed between and in contact with the hammer and the anvil. The workstring may contain a mud motor for delivering the rotational force. The apparatus may further include a retainer operatively associate with the protuberance for retaining the protuberance within the inner cavity. The workstring may be a tubular drill string or a coiled tubing string. The protuberance may rotate at a different rotational rate than the upper member and the bit body. Each of the rolling elements may include a spherical outer surface. The apparatus may

WO 2017/131969

PCT/US2017/013393

include two rolling elements in contact with one another, with a diameter of each of the rolling elements being approximately equal to one-half of an inner diameter of the inner cavity. Alternatively, the apparatus may include three or more rolling elements, with each of the rolling elements in contact with two adjacent rolling elements. In another alternative, the apparatus includes two or more rolling elements and a guide member, with the guide member disposed between the hammer and the anvil for retaining the rolling elements in a fixed position relative to one another.

[0011] A method of boring a wellbore includes the step of (a) providing a boring apparatus. The boring apparatus includes an upper member, a bit body, and a pilot bit. The upper member includes a first end, an inner cavity, and a second end. The first end is connected to a workstring, which is configured to deliver a rotational force to the upper member. The inner cavity contains a profile having a first radial cam surface. The bit body includes a first end, a second end, and a central bore extending from the first end to the second end. The first end of the bit body is operatively connected to the second end of the upper member, with the bit body configured to rotate with a rotation of the upper member. The second end of the bit body includes a working face containing a cutting member. The pilot bit is rotatively connected within the inner cavity of the upper member and extends through the central bore of the bit body beyond the working face of the bit body. The pilot bit includes a first end and a second end. The first end includes a second radial cam surface. The second end of the pilot bit includes an engaging surface configured to engage a formation surrounding the wellbore. The upper member and the bit body rotate relative to the pilot bit. The method further includes the steps of: (b) lowering the boring apparatus into the wellbore; (c) contacting the cutting member of the working face with a reservoir interface; (d) rotating the upper member and the bit body relative to the pilot bit; (e) engaging the engaging surface of the pilot bit with the reservoir interface in the wellbore; and (f) impacting the second radial cam surface with the first radial cam surface so that a hammering force is delivered to the cutting members and the engaging surface while boring the wellbore with the boring apparatus. The workstring may contain a mud motor for delivering the rotational force to the upper member. The workstring may be a tubular drill string or a coiled tubing string. The engaging surface of the pilot bit may include an eccentric conical surface or a chiseled surface. In step (d), the pilot bit may be rotated due to frictional forces associated with the rotation of the bit body and the upper member, with a rotation rate of the pilot bit being not equal to a rotation rate of the bit body. The boring apparatus may further include

WO 2017/131969

PCT/US2017/013393

one or more rolling elements disposed between and in contact with the first radial cam surface and the second radial cam surface, and step (f) may further include impacting the second radial cam surface with the first radial cam surface through the rolling elements.

BRIEF DESCRIPTION OF THE DRAWINGS

- 5 [0012] FIGURE 1 is a sectional view of one embodiment of the bit disclosed in this specification.
- [0013] FIGURE 2 is a perspective view of one embodiment of a cam surface on a pilot bit.
- [0014] FIGURE 3 is an enlarged, partial sectional view of the area marked as "A" in
10 FIGURE 1 which depicts the radial cam surface within the bit.
- [0015] FIGURE 4 is a perspective view of the pilot bit seen in FIGURE 1.
- [0016] FIGURE 5 is a sectional view of a second embodiment of the bit disclosed in this specification.
- [0017] FIGURE 6 is a perspective view of the second embodiment of the pilot bit
15 seen in FIGURE 5.
- [0018] FIGURE 7 is a cross-sectional view of the bit of FIGURE 1 taken along line A-A.
- [0019] FIGURE 8 is a cross-sectional view of a third embodiment of the bit disclosed in this specification.
- 20 [0020] FIGURE 9A is a perspective view of a radial cam surface of the bit shown in FIGURE 8.
- [0021] FIGURE 9B is a schematic view of the circumferential profile of the radial cam surface shown in FIGURE 9A.
- [0022] FIGURE 9C is a perspective view of an alternate radial cam surface.
- 25 [0023] FIGURE 10 is a cross-sectional view of a fifth embodiment of the bit disclosed in this specification.

WO 2017/131969

PCT/US2017/013393

- [0024] FIGURE 11 is an enlarged, partial sectional view of the area marked as “B” in FIGURE 10.
- [0025] FIGURE 12 is a schematic representation of a workstring extending from a rig, with the workstring being placed concentrically within a wellbore.
- 5 [0026] FIGURE 13 is a cross-sectional view of an apparatus for applying axial movement with a rotating member.
- [0027] FIGURE 14A is a cross-sectional view of the apparatus taken along line A—A in FIGURE 13.
- [0028] FIGURE 14B is an alternate cross-sectional view of the apparatus taken along
10 line A—A in FIGURE 13.
- [0029] FIGURE 14C is another alternate cross-sectional view of the apparatus taken along line A—A in FIGURE 13.
- [0030] FIGURE 14D is yet another alternate cross-sectional view of the apparatus taken along line A—A in FIGURE 13.
- 15 [0031] FIGURE 15 is a cross-sectional view of the apparatus of FIGURE 13 including a guide member.
- [0032] FIGURE 16A is a cross-sectional view of the apparatus taken along line B—B in FIGURE 15.
- [0033] FIGURE 16B is an alternate cross-sectional view of the apparatus taken along
20 line B—B in FIGURE 15.
- [0034] FIGURE 16C is another alternate cross-sectional view of the apparatus taken along line B—B in FIGURE 15.
- [0035] FIGURE 16D is yet another alternate cross-sectional view of the apparatus taken along line B—B in FIGURE 15.
- 25 [0036] FIGURE 17 is a cross-sectional-view of an alternate embodiment of the boring apparatus disclosed in this specification.

DETAILED DESCRIPTION OF THE PREFERRED EMBODIMENTS

[0037] Fig. 1 is a sectional view of one embodiment of the bit 2 disclosed in this specification. The bit 2 includes a first end 4 having an outer diameter that contains external thread means 6, wherein the external thread means 6 will connect to a workstring (not seen in this view). Bit 2 may be any tool that is capable of drilling a bore into a rock formation, such as a drag bit, a roller cone bit, a chisel-type bit, or a mill. As appreciated by those of ordinary skill in the art, the workstring may include a bottom hole assembly that includes measurement while drilling instruments, mud motor means, and drill collars (note that this list is illustrative). The external thread means 6 extends to a radial shoulder 8 which in turn extends to the outer conical surface 10. As seen in Fig. 1, the outer conical surface 10 extends to a plurality of blades, including blades 12 and 14. The bit 2, and in particular the blades 12, 14, contain cutting members for drilling and crushing subterranean rock as appreciated by those of ordinary skill in the art. In one embodiment, the blades 12, 14 comprise leg portions upon which the cutting members can be connected. For instance, Fig. 1 depicts cutting members 16, 18, 20, 22 connected to the distal ends 23 (also referred to as the working face 23) of the leg portions of the blades 12, 14. Hence, the cutting members 16, 18, 20, 22 are contained on the working face 23 of the bit 2.

[0038] The bit 2 also contains a radially flat top surface 24 which extends radially inward to the inner diameter portion 26. The inner diameter portion 26 stretches to the opening, seen generally at 28. Opening 28 is sometimes referred to as an inner cavity. The opening 28 has an internal profile 30, wherein the profile 30 contains a first radial cam surface which will be described with reference to Fig. 2. The opening 28 extends to the bottom of the bit 2. As seen in Fig. 1, disposed within the opening 28 is the pilot bit 32 (the pilot bit 32 may be referred to as the protuberance 32). Pilot bit 32 may, but need not, extend beyond working face 23 of bit 2. The pilot bit 32 has a first end (generally seen at 34) and a second end (generally seen at 36). The first end 34 contains a second radial cam surface which will be described with reference to Fig. 3. It should be noted that the first and second radial cam surfaces cooperate together as will be more fully explained later in the disclosure.

[0039] As seen in Fig. 1, the opening 28 further includes the increased diameter circumference area 38 which is adapted for placement of retainer 40 therein for retaining pilot bit 32 within opening 28. Retainer 40 may be ball members as shown. Alternatively, retainer 40 may be a pin, set screw, or other similar mechanism disposed at least partially within

WO 2017/131969

PCT/US2017/013393

opening 28 for retaining pilot bit 32 within opening 28. Any number of retainers 40 may be included. More specifically, the pilot bit 32 contains a first outer diameter surface 42 which stretches to the chamfered surface 44 which in turn extends to the second outer diameter surface 46, then to the chamfered surface 48, then to third outer diameter surface 50. In the embodiment depicted in Fig. 1, the third outer diameter surface 50 extends to the chiseled profile surface, seen generally at 52, with the chiseled profile surface 52 having a beveled end 54 for contacting the subterranean rock. The center line 56 runs through the inner diameter portion 26 of the bit 2 as well as through the beveled end 54 of the pilot bit 32. The ball bearing members 40 allow the rotation of the bit 2 as well as the rotation of the pilot bit 32. In one embodiment, ball bearing members 40 allow bit 2 and pilot bit 32 to rotate at different speeds such that the bit 2 may have a first rotation rate, measured in revolutions per minute (RPM), while the pilot bit 32 may have a second rotation rate, also measured in RPM. First and third outer diameter surfaces 42 and 50 of pilot bit 32 may function as radial bearings, along with the inner surfaces of opening 28 of bit 2.

15 [0040] Referring now to Fig. 2, a perspective view of one embodiment of the second radial cam surface 60 on the pilot bit 32 will now be described. It should be noted that like numbers refer to like components in the various drawings. Fig. 2 depicts the outer diameter surface 42 as well as the outer diameter surface 50, with the outer diameter surface 50 extending to the chiseled profile surface 52. In one embodiment, the second radial cam surface 60 contains three ramps, namely ramps 62, 64, 66. The ramps 62, 64, and 66 will cooperate with the internal profile 30 to deliver the hammering force as will be more fully explained below. The ramp 66 contains an upstanding portion 68, an inclined portion 70 and a flat portion 72 that is intermediate of the inclined portion 70 and upstanding portion 70. The ramps 62, 64, and 66 are of similar construction. The radially flat area 74a, 74b, 74c will be the area that the two radial cams will impact during the hammering action. In other words, the radially flat areas 74a, 74b, 74c receive the hammering force and not the ramp surfaces.

30 [0041] Referring specifically to Fig. 3, which is an enlarged partial sectional view of the circled area marked "A" in Fig. 1 will now be described. Fig. 3 depicts the first radial cam surface 80 on the internal profile 30 of bit 2. Fig. 3 shows the inclined portion 82 which stretches to the upstanding portion 84 that then levels off to a flat portion 86. The radially flat area is depicted at 88. The inclined portion 82, upstanding portion 84, the flat portion 86,

WO 2017/131969

PCT/US2017/013393

and the radially flat area 88 are reciprocal with the second radial cam surface 60 previously described. The second radial cam surface 60 will cooperate with first radial cam surface 80 in order to generate a hammer force as per the teachings of this disclosure. Internal profile 30 engages and cooperates with second radial cam surface 60 so that as bit 2 rotates relative to pilot bit 32 (i.e., pilot bit 32 does not rotate or pilot bit 32 rotates at a different rotational rate than bit 2), flat portion 86 of internal profile 30 slides up inclined portion 70, across flat portion 72, over upstanding portion 68, and onto flat area 74b of second radial cam surface 60. As flat portion 86 falls onto flat area 74b of second radial cam surface 60, a percussive force will be generated in an axial direction through bit 2 and pilot bit 32 for assisting in drilling through a subterranean formation. In one embodiment, the second radial cam surface 60 is an anvil member and the first radial cam surface 80 is a hammer member.

[0042] Fig. 4 is a perspective view of the first embodiment of the pilot bit member, namely pilot bit 32. As seen in Fig. 4, the outer diameter surface 50 extends to the first concave surface 90 as well as the second concave surface 92 which in turn extends to the beveled end 54. Hence, as drilling progresses, the beveled end 54 may contact the subterranean rock which in turn will be crushed and chiseled.

[0043] Fig. 5 is a sectional view of a second embodiment of bit 94, with Fig. 5 depicting the second embodiment of the pilot bit 96 containing the eccentric conical surface 98. The bit 94 is the same as the bit 2 depicted in Fig. 1 except for the pilot bit 96. As seen in Fig. 5, the center line 100 through the center of the bit 94 is offset from the apex 102 of the cone portion 104 of pilot bit 96. The center line 106 of the cone portion 104 is offset from the center line 100 of the bit 94 thereby forming an eccentric conical surface 104. Because of this offset (i.e., the eccentric distance), a higher torque is required to rotate pilot bit 96, which in turn requires a higher friction between the radial cam surfaces of bit 94 and pilot bit 96 in order to rotate pilot bit 96. With a greater eccentric distance of apex 102, a higher torque will be required to rotate pilot bit 96. Thus, the eccentric distance produces a higher difference between the rotational rate of bit 2 and the rotational rate of pilot bit 96 (i.e., a higher relative rotation), thereby increasing the frequency of impacts created by the interaction of the radial cam surfaces.

[0044] Referring now to Fig. 6, a perspective view of the second embodiment of the pilot bit member 96 seen in Fig. 5 will now be described. The pilot bit 96 contains at the distal end the cone portion 104 that leads to the apex 102. The cone portion 104 is

WO 2017/131969

PCT/US2017/013393

eccentrically positioned which forms a radial area 108. The cone portion 104 may be integrally formed on the body of the pilot bit 96 or may be attached such as by welding.

[0045] Fig. 7 is a cross-sectional view of the bit 2 of Fig. 1 taken along line 7-7. Hence, the pilot bit 32 is shown along with the ball bearing members, such as member 40, with the ball bearing member 40 being positioned in the increased diameter circumference area 38. Also shown are the blades 12, 14 along with blade 109. Fig. 7 shows how the bit 2 may rotate in a clockwise direction 110 relative to pilot bit 32. While bit 2 is configured to rotate, pilot bit 32 is not designed to rotate. Accordingly, pilot bit 32 may be a non-rotating member. In one embodiment, however, frictional forces may cause pilot bit 32 to rotate. In that case, pilot bit 32 will rotate at a different rotational rate than bit 2.

[0046] Fig. 8 illustrates another embodiment of bit 113. Except as otherwise noted, bit 113 is the same as bit 2. Bit 113 may include blades 114 and 115. Bit 113 may also include inner cavity 116 extending at least from radial cam surface 117 to radial surface 118. Pilot bit 119 may include shaft portion 120 extending from upper portion 121 to cone portion 122. Apex 123 of cone portion 122 may be offset from center line 124 of bit 113. Upper portion 121 may include radial cam surface 125 and radial shoulder 126. Radial surface 118 of bit 113 may retain upper portion 121 of pilot bit 119 within inner cavity 116.

[0047] Bit 113 may further include rolling elements 127 and 128 positioned between and in contact with radial cam surfaces 117 and 125. Rolling elements 127, 128 may also be referred to as rotating elements. In one preferred embodiment, rolling elements 127, 128 are spherical members such as stainless steel ball bearings or ceramic balls. In this embodiment, each spherical member may have a diameter that is approximately equal to one-half of the inner diameter of inner cavity 116, such that the spherical members are in contact with one another. It should be understood that bit 113 may include any number of rolling elements. The number of rolling elements included may be equal to the number of high points or ramps on each of radial cam surfaces 117 and 125. Each of the rolling elements may be the same size.

[0048] Rolling elements 127, 128 may be free to move between radial cam surfaces 117 and 125 as bit 113 rotates relative to pilot bit 119. In one embodiment, rolling elements 127, 128 may move in a circular path on radial cam surface 125 as bit 113 rotates relative to pilot bit 119. This movement of rolling elements 127, 128 over radial cam surfaces 117 and

WO 2017/131969

PCT/US2017/013393

125 may cause axial movement of pilot bit 119 relative to bit 113. Use of rolling elements 127, 128 allows for less of a direct impact between radial cam surfaces 117 and 125 of bit 113 and pilot bit 119, which may increase the life of bit 113 and pilot bit 119.

[0049] Fig. 9A illustrates a first embodiment of radial cam surface 125. In this embodiment, radial cam surface 125 includes a series of surfaces, namely surfaces **125a**, **125b**, **125c**, **125d**, **125e**, **125f**, **125g**, **125h**, **125i**, **125j**, **125k**, **125l**. Several of these surfaces may have a rising or falling slope such that radial cam surface 125 has a multiple segmented radial face. Fig. 9B is a circumferential profile view of radial cam surface 125 shown in Fig. 9A. Fig. 9C illustrates another embodiment of radial cam surface 125. In this embodiment, radial cam surface 125 includes cam low side **126a** and cam high side **126b**. The profile of this embodiment of radial cam surface 125 may be a smoother waveform. In one embodiment, the profile of radial cam surface 125 is a sinusoidal waveform. It should be noted that the embodiments of radial cam surface 125 shown in Figs. 9A and 9C may both be referred to as an undulating profile. Radial cam surface 117 of bit 113 may have a reciprocal shape to radial cam surface 125. Alternatively, one of radial cam surfaces 117 and 125 may be a flat radial surface.

[0050] Fig. 10 is a sectional view of a yet another embodiment of bit **130**. Except as otherwise noted, bit 130 is the same as bit 2. Bit 130 may include blades **132** and **134**. Bit 130 may also include inner cavity **136** leading from radial cam surface **138** and hammer surface **140** to working face **142**. Radial cam surface 138 and hammer surface 140 may be axially separated by a distance. Pilot bit **144** may be disposed within inner cavity 136 of bit 130. Pilot bit 144 may include first end **146** and second end **148**. First end 146 may include radial cam surface **150** and anvil surface **152**. Radial cam surface 150 and anvil surface 152 may be axially separated by a distance. Radial cam surface 150 may cooperate with radial cam surface 138, and anvil surface 152 may cooperate with hammer surface 140. Second end 148 of pilot bit 144 may include a chiseled profile surface (as shown) or an eccentric conical portion of the type discussed above.

[0051] Fig. 11 is an enlarged view of the section B in Fig. 10. This view shows that when hammer surface 140 of bit 130 is in contact with anvil surface 152 of pilot bit 144, radial cam surfaces 138 and 150 are separated by the distance ΔX . As bit 130 rotates relative to pilot bit 144, radial cam surface 138 of bit 130 engages radial cam surface 150 of pilot bit 144. As explained above in connection with other embodiments, each high point **154** on

WO 2017/131969

PCT/US2017/013393

radial cam surface 138 slides along each ramp 156 of radial cam surface 150. During this time, hammer surface 140 will separate from anvil surface 152. When each high point 154 of radial cam surface 138 slides over each high point 158 of radial cam surface 150, each high point 154 will drop over upstanding portions 160 of radial cam surface 150. This drop causes hammer surface 140 of bit 130 to impact anvil surface 152 of pilot bit 144. Because of the separation by distance ΔX , the impact force is not placed directly on radial cam surfaces 138 and 150. This arrangement will increase longevity of bit 130 and pilot bit 144 by reducing wear on radial cam surfaces 138 and 150. This embodiment may also include one or more rolling elements between radial cam surfaces 138 and 150. Where rolling elements are used, rolling elements may not be in contact with both cam surfaces when hammer surface 140 contacts and impacts anvil surface 152.

[0052] Referring now to Fig. 12, a schematic representation of a workstring 230 extending from a rig 232, with the workstring 230 being placed concentrically within a wellbore 234. The workstring 230 will be operatively connected to a bottom hole assembly, seen generally at 236. In the embodiment of Fig. 12, the bottom hole assembly 236 includes a mud motor means 238 for rotatively driving the bit 2. As understood by those of ordinary skill in the art, in the course of drilling a well, a drilling fluid is pumped through the workstring 230. The drilling fluid is channeled through the mud motor means thereby causing a segment of the bottom hole assembly to rotate. The rotative force is transferred to the bit 2 which will cause the bit 2 to be rotated relative to the pilot bit 32. Hence, the bit 2 is rotated so that a first rotation rate is achieved. The cutting members (e.g., cutting members 16, 18, 20, 22 shown in Fig. 1) contained on the working face 23 will also engage with the reservoir interface 240. The beveled end 54 of the pilot bit 32 (shown in Fig. 4), the apex 102 of pilot bit 96 (shown in Fig. 6), or the apex 123 of pilot bit 119 will engage the reservoir interface 240. It should be understood that unless otherwise noted, the bits 2, 94, 113, and 130 function in the same way and pilot bits 32, 96, 119, and 144 function in the same way.

[0053] Pilot bit 32 may not rotate during boring operations. However, relative rotation of bit 2 relative to pilot bit 32 may cause pilot bit 32 to rotate due to frictional forces. Relative rotation between bit 2 and pilot bit 32 may be caused by sliding and rolling friction between bit 2 and pilot bit 32 and by friction between both members and the reservoir rock surrounding the wellbore. Bit 2 and pilot bit 32 may require different torque values to overcome the rolling friction and friction with the reservoir rock, which may cause rotation of

WO 2017/131969

PCT/US2017/013393

pilot bit 32 at a different rotation rate than that of bit 2. Relative rotation may also be caused by the eccentric offset of apex 102 from the center line of bit 94 when pilot bit 96 is used. Bit 2 may rotate at a higher rotation rate or speed than pilot bit 32. For example, the bit may rotate at 80-400 RPM, while the pilot bit may rotate at 2-10 RPM. The method further includes impacting the second radial cam surface 60 against the first radial cam surface 80 so that a percussive force is delivered to the working face 23 and the pilot bit 32. In this way, the relative rotation between bit 2 and pilot bit 32 is converted into a relative axial movement between bit 2 and pilot bit 32. The cutting and crushing action of the cutting members 16, 18, 20, 22 and pilot bit 32 coupled with the hammering force will drill the wellbore.

10 **[0054]** As previously noted, in one embodiment, the first radial cam surface comprises an inclined portion and upstanding portion and the second radial cam surface comprises an inclined portion and upstanding portion that are reciprocal and cooperate to create the hammering force on the radially flat areas, such as areas 74a, 74b, 74c seen in Fig. 2. In one embodiment, the workstring contains a mud motor for delivering a rotational force; however, other embodiments include surface rotary means for imparting rotation of the workstring from the rig floor. In another embodiment, the workstring is selected from the group consisting of a tubular drill string, a coiled tubing string, and snubbing pipe. A feature of one embodiment is that the engaging surface (i.e. distal end of the pilot bit 32) may be an eccentric conical surface, a chiseled surface, or other similar surface.

20 **[0055]** Fig. 13 illustrates apparatus 302 including rotating member 304 (sometimes referred to as rotating segment) and second member 306 (sometimes referred to as second segment). Rotating member 304 and second member 306 may each be at least partially disposed within housing 308. Rotating member 304 may include first radial surface 310. Second member 306 may include second radial surface 312 opposing first radial surface 310. First radial surface 310 or second radial surface 312 may include a tapered surface as described above. In one embodiment, both radial surfaces 310, 312 include a tapered surface. The tapered surface may be an undulating waveform profile. It should be understood that rotating member 304 may be positioned above or below second member 306.

30 **[0056]** Apparatus 302 may include one or more rolling elements 314. In one embodiment, apparatus 302 includes two rolling elements 314a, 314b as shown in Fig. 13. Each rolling element may have, but is not limited to, a spherical outer surface having a diameter that is approximately equal to one-half of an inner diameter of housing 308 such

WO 2017/131969

PCT/US2017/013393

that rolling elements 314a and 314b are in constant contact with one another. It should be understood that apparatus 302 may include any number of rolling elements. The number of rolling elements included in the downhole apparatus may be equal to the number of high points or ramps on each of radial surfaces 310 and 312. Each of the rolling elements may be the same size.

5 [0057] Rotating member 304 may rotate continuously relative to second member 306, i.e., rotating member 304 may rotate more than 360 degrees relative to second member 306. In one embodiment, second member 306 is a non-rotating member. Non-rotating member means that the member is not designed to rotate and the member is substantially non-rotating relative to the rotating member. In another embodiment, second member 306 is a member 10 rotating at a different rotation rate than rotating member 304. Rotation rate is the speed of rotation, which may be measured in units of rotation or revolutions per minute (RPM). In a further embodiment, second member 306 and rotating member 304 rotate in opposite directions. In all embodiments, as rotating member 304 rotates relative to second member 15 306, rolling elements 314 move between first and second radial surfaces 310 and 312 thereby producing an axial movement of second member 306 relative to rotating member 304. Rolling elements 314 may each move 360 degrees along a circular path relative to second radial surface 312. Rolling elements 314 may also each move 360 degrees along a circular path relative to first radial surface 310. The movement of rolling elements 314 on first and 20 second radial surfaces 310 and 312 may occur simultaneously, such that rolling elements 314 move 360 degrees along a circular path relative to the first radial surface 310 and simultaneously move 360 degrees along a circular path relative to the second radial surface 312.

[0058] It should be understood that apparatus 302 is not limited to the directional and 25 inclinational arrangement shown. In other words, apparatus 302 will function as long as first radial surface 310 opposes second radial surface 31 with one or more rolling elements disposed between. Apparatus 302 may be arranged in an inverted vertical position relative to the one shown in these drawings. Apparatus 302 may also be arranged in a horizontal position or any other inclinational position.

30 [0059] Fig. 14A is a cross-sectional view taken along line A—A in Fig. 13 showing rolling elements 314a, 314b on first radial surface 310 disposed within housing 308. Fig. 14B is an alternate cross-sectional view taken along line A—A in Fig. 13. In this

WO 2017/131969

PCT/US2017/013393

embodiment, apparatus 302 includes three rolling elements, namely rolling elements 314a, 314b, 314c. Fig. 14C is another alternate cross-sectional view taken along line A—A in Fig. 13 showing apparatus 302 including four rolling elements, namely rolling elements 314a, 314b, 314c, 314d. Fig. 14D is yet another alternate cross-sectional view taken along line A—
5 A in Fig. 13 showing apparatus 302 including ten rolling elements, namely rolling elements 314a, 314b, 314c, 314d, 314e, 314f, 314g, 314h, 314i, 314j. Each rolling element in Figs. 14B, 14C, and 14D may be dimensioned such that each rolling element is in contact with two adjacent rolling elements.

[0060] Fig. 15 illustrates apparatus 302 having guide member 316 disposed between
10 radial surfaces 310 and 312. Guide member 316 may be used to contain rolling elements 314a and 314b in a fixed position relative to one another. Fig. 16A is a cross-sectional view taken along line B—B in Fig. 15 showing rolling elements 314a, 314b retained by guide member 316 on first radial surface 310 disposed within housing 308. In this embodiment, rolling elements 314a, 314b are dimensioned so that they are in constant contact with one
15 another. Fig. 16B is an alternate cross-sectional view taken along line B—B in Fig. 15. In this embodiment, apparatus 302 includes two rolling elements 314a, 314b, with the rolling elements dimensioned so that they are separated from one another. Guide member 316 retains rolling elements 314a, 314b in a fixed position relative to one another, such as 180 degrees apart. Fig. 16C is another alternate cross-sectional view taken along line B—B in
20 Fig. 15. In this embodiment, apparatus 302 includes three rolling elements 314a, 314b, 314c, with the rolling elements dimensioned so that they are separated from one another and retained in a fixed position relative to one another by guide member 316, such as 120 degrees apart. Fig. 16D is yet another alternate cross-sectional view taken along line B—B in Fig. 15. In this embodiment, apparatus 302 includes four rolling elements 314a, 314b, 314c, 314d,
25 with the rolling elements dimensioned so that they are separated from one another and retained in a fixed position relative to one another by guide member 316, such as 90 degrees apart. It is to be understood that guide member 316 may be used with any number of rolling elements 314. Use of guide member 316 is preferred when rolling elements 314 are dimensioned so that each rolling element does not constantly contact two adjacent rolling
30 elements, such as in the embodiments shown in Figs. 16B, 16C, and 16D.

[0061] Fig. 17 illustrates boring apparatus 400 including upper member 402, bit 404, and pilot bit 406. Upper member 402 may include upper end 408 having an outer diameter

WO 2017/131969

PCT/US2017/013393

that contains external thread means 410. External thread means 410 may connect to a workstring. External thread means 410 may extend to radial shoulder 412. Upper member 402 may also include outer surface 414 extending from radial shoulder 412 to lower radial surface 416 on lower end 418 of upper member 402. Upper member 402 may further include
 5 inner cavity 420 including radial cam surface 422 and radial surface 424. Bore 426 of upper member 402 may extend from inner cavity 420 to lower cavity 428 having internal thread means 430. Internal thread means 430 may extend to lower radial surface 416. Upper member 402 may be any component of a downhole drilling assembly that is operatively connected to a drill bit or other tool capable of drilling a bore into a rock formation. For
 10 example, upper member 402 may be, but is not limited to, a component of a bottom hole assembly that includes measurement while drilling instruments, mud motor means, and drill collars.

[0062] Upper end 432 of bit 404 may include external thread means 434 extending to radial shoulder 436. Lower end 438 of bit 404 may include blades 440 and 442. Internal
 15 bore 444 may extend through bit 404 from upper end 432 to lower end 438. Except as otherwise noted, bit 404 may include the same features as bit 2 and bit 113. Upper end 432 of bit 404 may be disposed within lower cavity 428 with external thread means 434 of bit 404 engaging internal thread means 430 of upper member 402. In this way, bit 404 and upper member 402 are threadedly connected such that lower radial surface 416 of upper member
 20 402 engages radial shoulder 436 of bit 404.

[0063] Pilot bit 406 may include shaft portion 446 extending from upper portion 448 to cone portion 450. Apex 452 of cone portion 450 may be offset from center line 454 of upper member 402 and bit 404. Upper portion 448 may be disposed within inner cavity 420 of upper member 402. Upper portion 448 may include radial cam surface 456 and radial
 25 shoulder 458. Radial shoulder 458 of pilot bit 406 may engage radial surface 424 of upper member 402 to retain upper portion 448 within inner cavity 420. Shaft portion 446 of pilot bit 406 may be disposed through bore 426 of upper member 402 and through internal bore 444 of bit 404. Bore 426 and internal bore 444 may each be configured to receive shaft portion 446 of pilot bit 406. In one embodiment, bore 426 and internal bore 444 have inner
 30 diameters that are approximately equal.

[0064] Apparatus 400 may further include rolling elements 460 and 462 disposed in inner cavity 420 between and in contact with radial cam surface 422 of upper member 402

WO 2017/131969

PCT/US2017/013393

and radial cam surface 456 of pilot bit 406. Rolling elements 460 and 462 may also be referred to as rotating elements. In one preferred embodiment, rolling elements 460 and 462 are spherical members such as stainless steel ball bearings or ceramic balls. In this embodiment, each spherical member may have a diameter that is approximately equal to one-half of an inner diameter of inner cavity 420, such that the spherical members are in contact with one another. It should be understood that apparatus 400 may include any number of rolling elements. The number of rolling elements included may be equal to the number of high points or ramps on each of radial cam surfaces 422 and 456. Each of the rolling elements may be the same size. Radial cam surfaces 422 and 456 may each include any of the shapes described above in connection with Figs. 9A, 9B, and 9C showing radial cam surface 125.

[0065] Upper member 402 and bit 404 may rotate relative to pilot bit 406. Rolling elements 460 and 462 may be free to move between radial cam surfaces 422 and 456 as upper member 402 rotates relative to pilot bit 406. In one embodiment, rolling element 460 and 462 may move in a circular path on each radial cam surface 422 and 456 as upper member 402 rotates relative to pilot bit 406. This movement of rolling elements 460 and 462 over radial cam surfaces 422 and 456 may cause axial movement of pilot bit 406 relative to upper member 402 and bit 404. Use of rolling elements 460 and 462 allows for less of a direct impact between radial cam surfaces 422 and 456, which may increase the life of upper member 402 and pilot bit 406. Boring apparatus 400 may be similar in design to bit 113 shown in Fig. 8 except that the rolling elements are disposed within a cavity of upper member instead of a cavity in the bit.

[0066] In another embodiment, apparatus 400 may be configured for use without rolling elements such that radial cam surfaces 422 and 456 directly contact one another to create an axial movement of pilot bit 406 relative to bit 404 as described in connection with Figs. 1-7. In yet another embodiment, apparatus 400 may be configured for use without rolling elements and with a hammer surface on upper member 402 designed to impact an anvil surface on pilot bit 406 to create an axial movement of pilot bit 406 relative to bit 404 as described in connection with Figs. 10-11.

[0067] Although the present invention has been described in considerable detail with reference to certain preferred versions thereof, other versions are possible. Therefore, the

WO 2017/131969

PCT/US2017/013393

spirit and scope of the appended claims should not be limited to the description of the preferred versions contained herein.

We claim:

1. An apparatus for boring a wellbore, the wellbore containing a workstring concentrically positioned therein, the apparatus comprising:

an upper member having a first end, an inner cavity, and a second end, wherein the first end is connected to the workstring, the workstring configured to deliver a rotational force to the upper member, wherein the inner cavity contains a profile having a first radial cam surface;

a bit body having a first end, a second end, and a central bore extending from the first end to the second end, the first end of the bit body operatively connected to the second end of the upper member, wherein the bit body is configured to rotate with a rotation of the upper member, wherein the second end of the bit body includes a working face containing a cutting member;

a pilot bit rotatively connected within the inner cavity of the upper member and extending through the central bore of the bit body beyond the working face of the bit body, wherein the pilot bit includes a first end and a second end, wherein the first end includes a second radial cam surface operatively configured to cooperate with the first radial cam surface to deliver a hammering force, and wherein the second end of the pilot bit includes an engaging surface configured to engage a formation surrounding the wellbore;

at least two rolling elements in contact with one another, and wherein a diameter of each of the at least two rolling elements is approximately equal to one-half of an inner diameter of the inner cavity;

wherein the upper member and the bit body rotate relative to the pilot bit.

2. The apparatus of claim 1, wherein the first radial cam surface and the second radial cam surface each comprises an inclined portion and an upstanding portion.
3. The apparatus of claim 2, wherein the engaging surface of the pilot bit comprises an eccentric conical surface or a chiseled surface.
4. The apparatus of claim 2, further comprising a retainer operatively associated with the pilot bit for retaining the pilot bit within the inner cavity.
5. The apparatus of claim 2, further comprising one or more rolling elements disposed between and in contact with the first radial cam surface and the second radial cam surface.
6. The apparatus of claim 1, wherein each of the at least two rolling elements includes a spherical outer surface.
7. The apparatus of claim 1, wherein the at least two rolling elements comprises three or more rolling elements, wherein each of the three or more rolling elements is in contact with two adjacent rolling elements.
8. The apparatus of claim 1, further comprising a guide member, the guide member disposed between the first and second radial cam surfaces for retaining the at least two rolling elements in a fixed position relative to one another.

9. A method of boring a wellbore comprising the steps of:
- a) providing a boring apparatus comprising: an upper member having a first end, an inner cavity, and a second end, wherein the first end is connected to a workstring, which is configured to deliver a rotational force to the upper member, wherein the inner cavity contains a profile having a first radial cam surface; a bit body having a first end, a second end, and a central bore extending from the first end to the second end, the first end of the bit body operatively connected to the second end of the upper member, wherein the bit body is configured to rotate with a rotation of the upper member, wherein the second end of the bit body includes a working face containing a cutting member; a pilot bit rotatively connected within the inner cavity of the upper member and extending through the central bore of the bit body beyond the working face of the bit body, wherein the pilot bit includes a first end and a second end, wherein the first end includes a second radial cam surface, and wherein the second end of the pilot bit includes an engaging surface configured to engage a formation surrounding the wellbore; at least two rolling elements in contact with one another, and wherein a diameter of each of the at least two rolling elements is approximately equal to one-half of an inner diameter of the inner cavity; wherein the upper member and the bit body rotate relative to the pilot bit;
 - b) lowering the boring apparatus into the wellbore;
 - c) contacting the cutting member of the working face with a reservoir interface;
 - d) rotating the upper member and the bit body relative to the pilot bit; causing the at least two rolling elements to move over the first and second radial cam surfaces resulting in axial movement of the pilot bit relative to the upper member and bit body to make contact with the reservoir interface while boring the wellbore with the bit apparatus.

10. The method of claim 9, wherein the workstring contains a mud motor for delivering the rotational force to the upper member.

11. The method of claim 10, wherein the workstring is a tubular drill string or a coiled tubing string.

12. The method of claim 9, wherein the engaging surface of the pilot bit is an eccentric conical surface or a chiseled surface.

13. The method of claim 9, wherein in step (d) the pilot bit is rotated due to frictional forces associated with the rotation of the bit body and the upper member, wherein a rotation rate of the pilot bit is not equal to a rotation rate of the bit body.

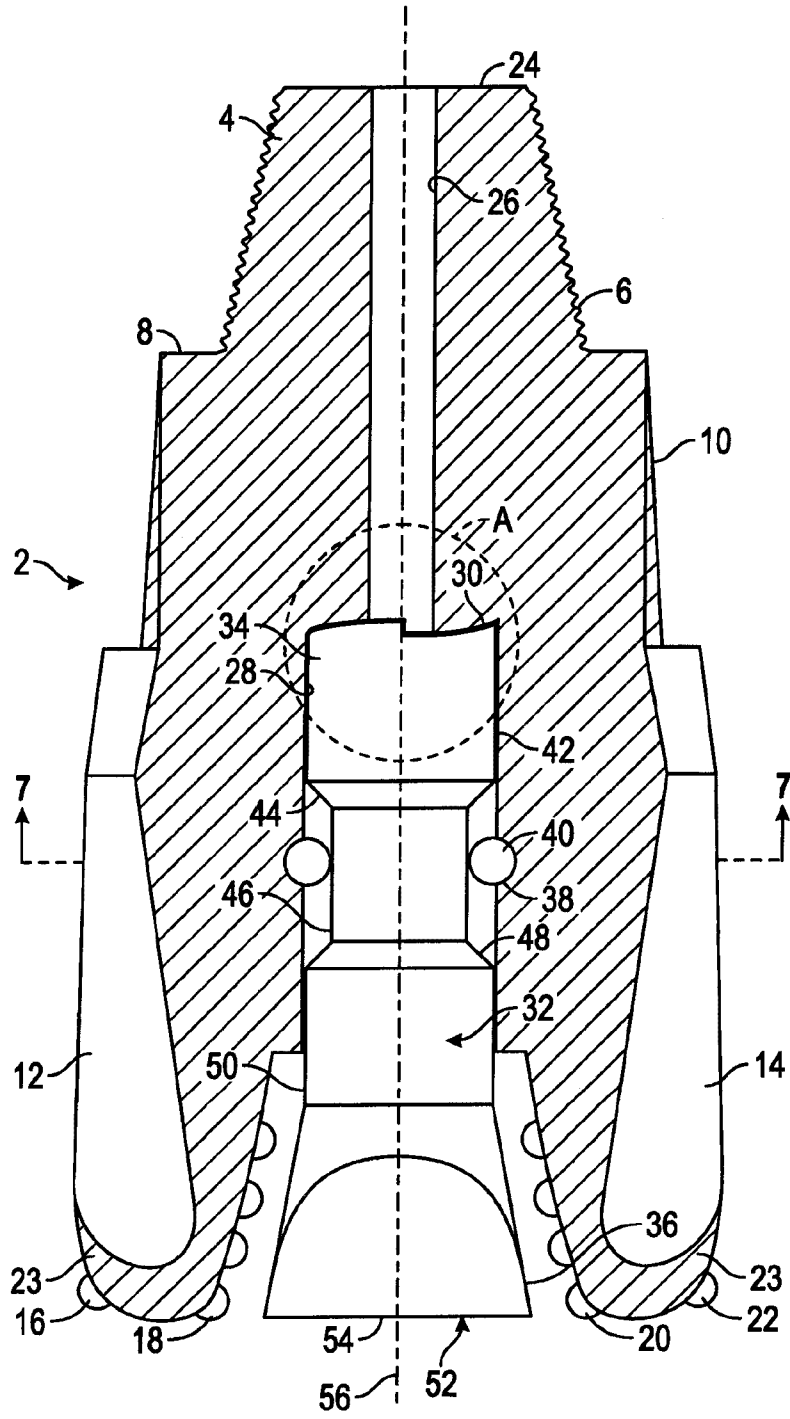

FIG. 1

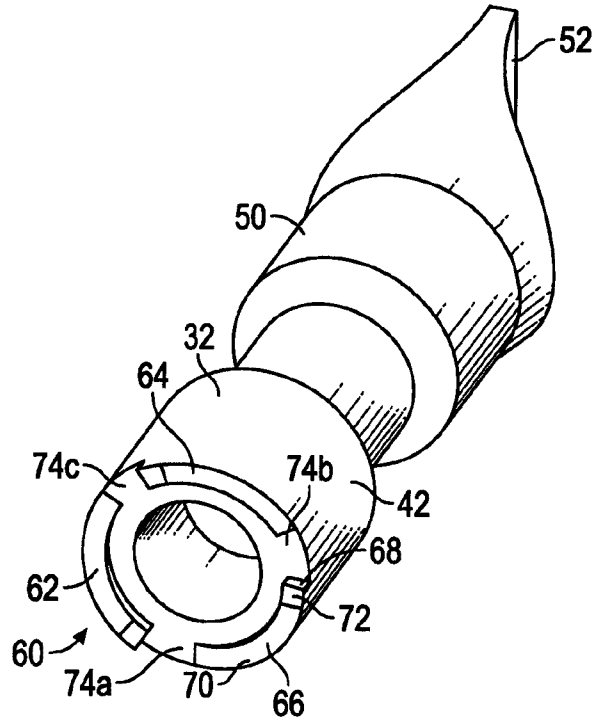

FIG. 2

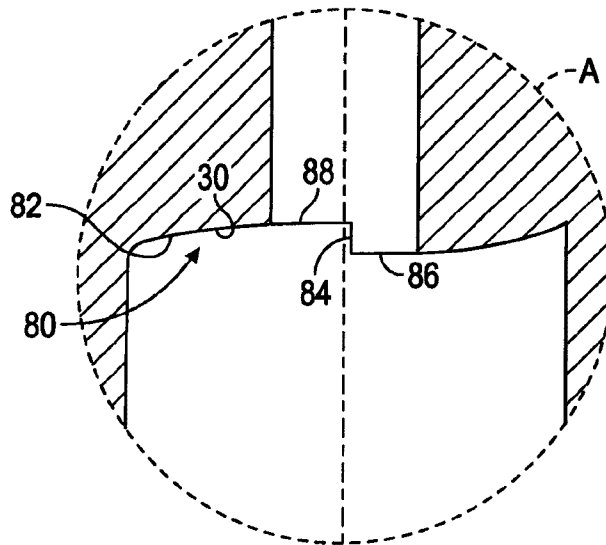

FIG. 3

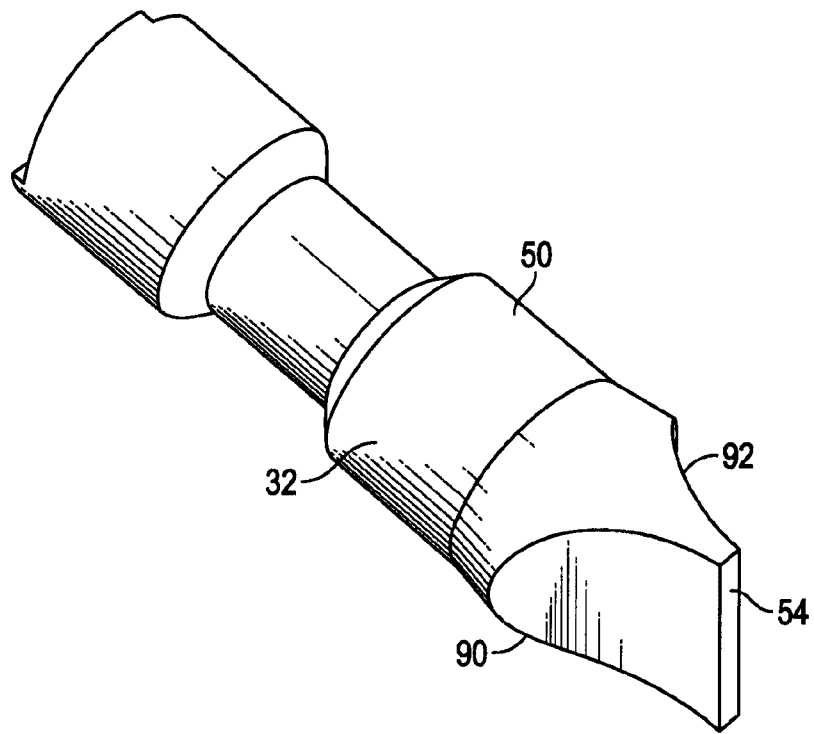

FIG. 4

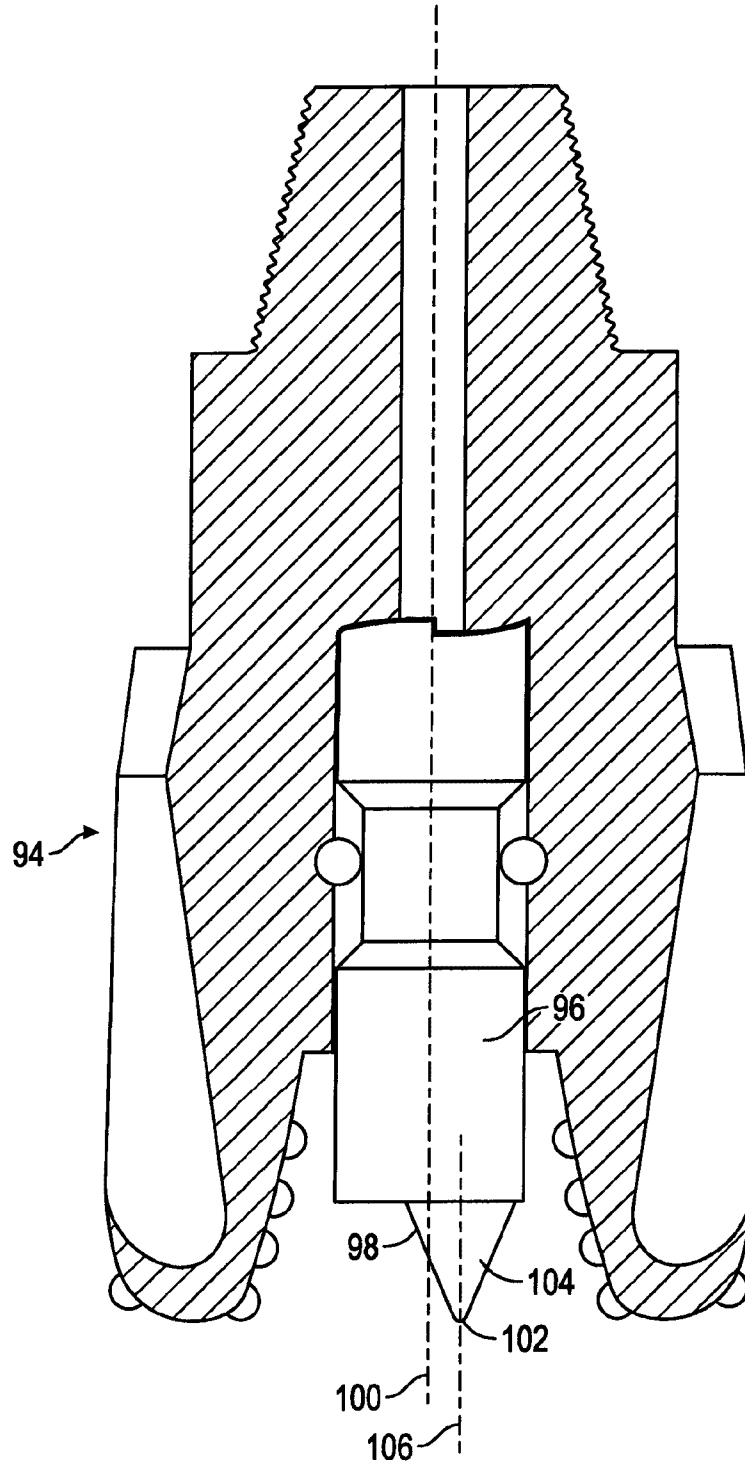

FIG. 5

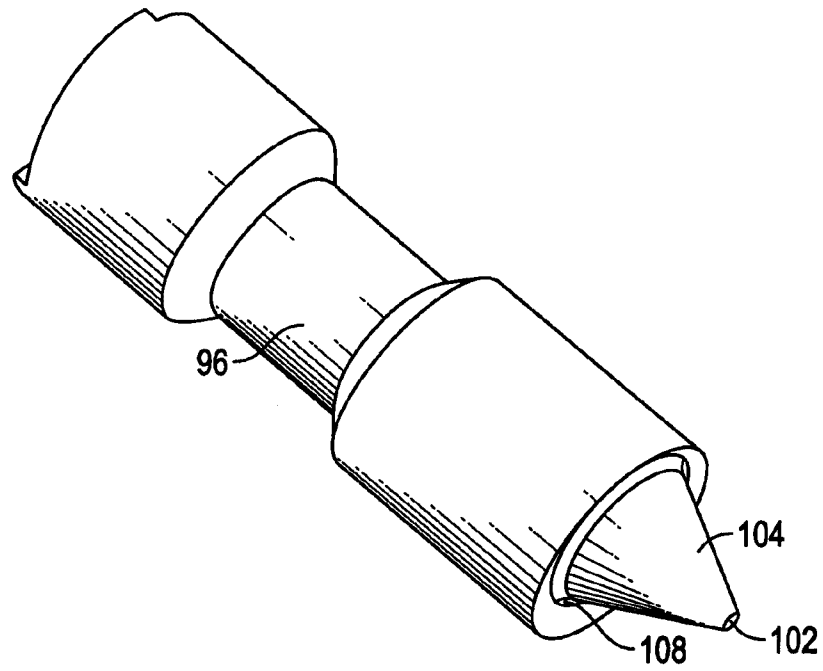

FIG. 6

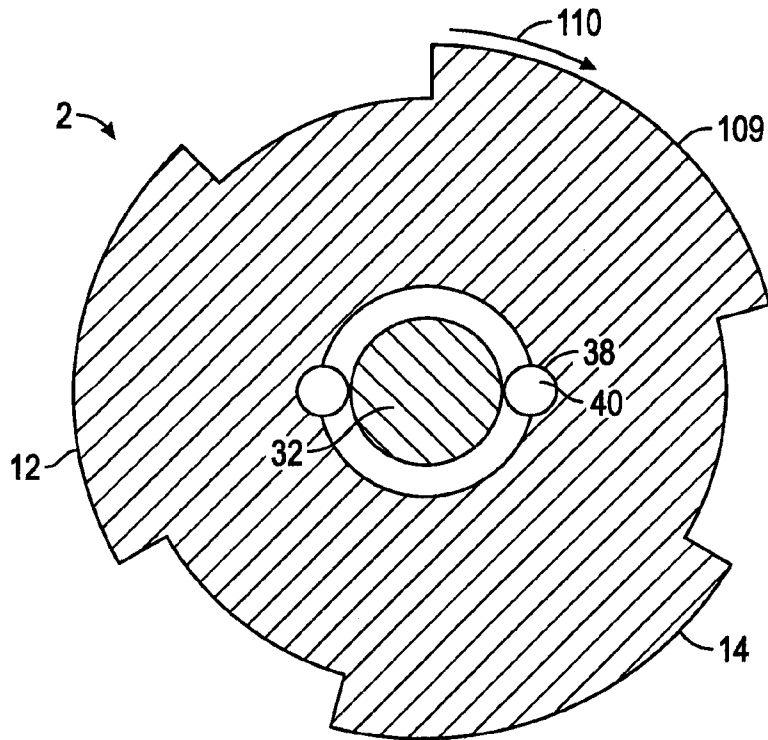

FIG. 7

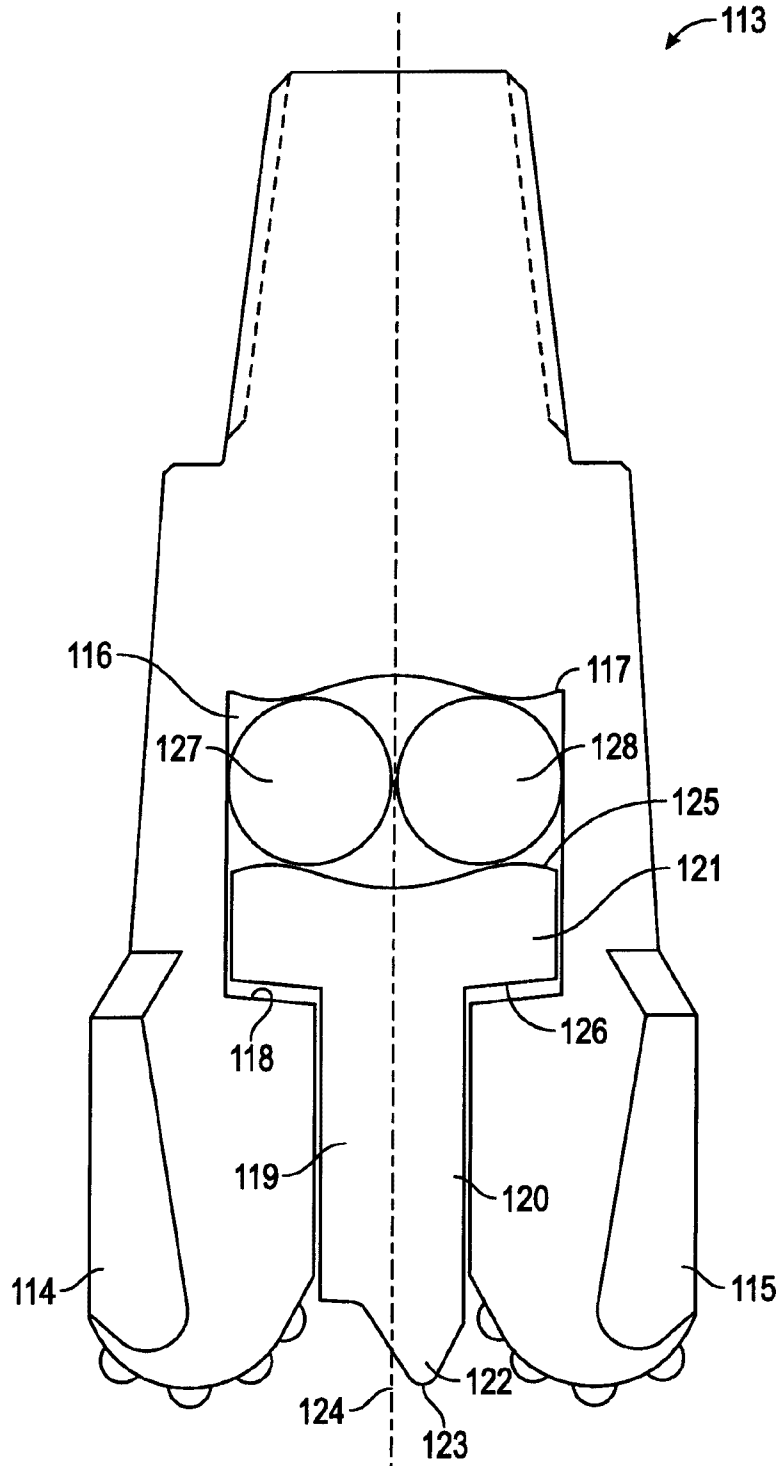

FIG. 8

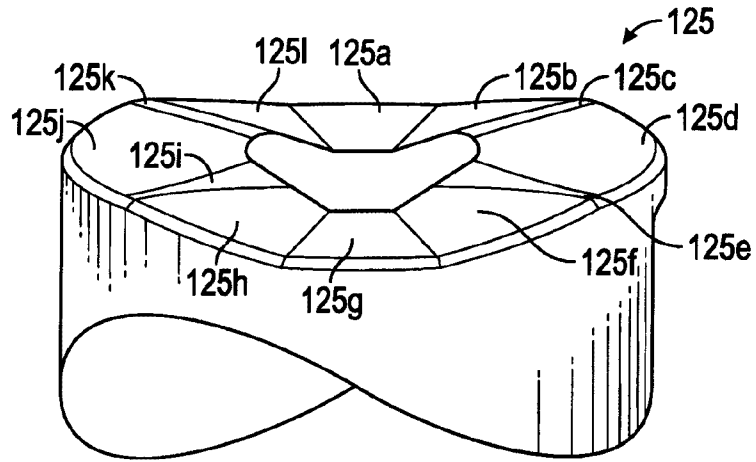

FIG. 9A

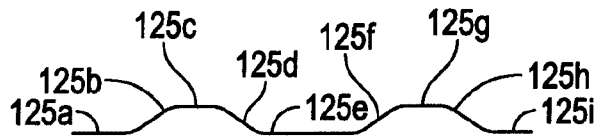

FIG. 9B

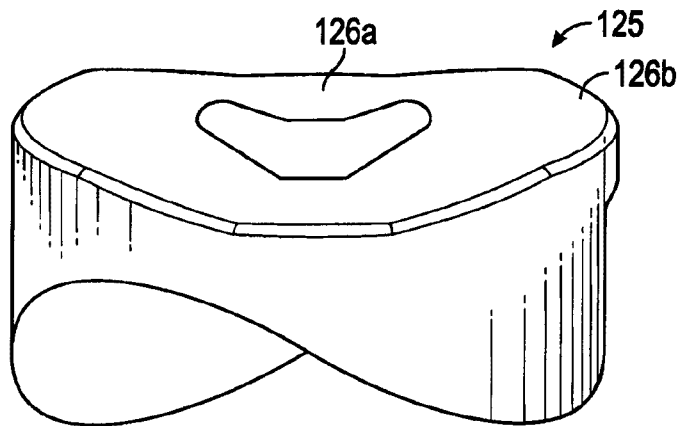

FIG. 9C

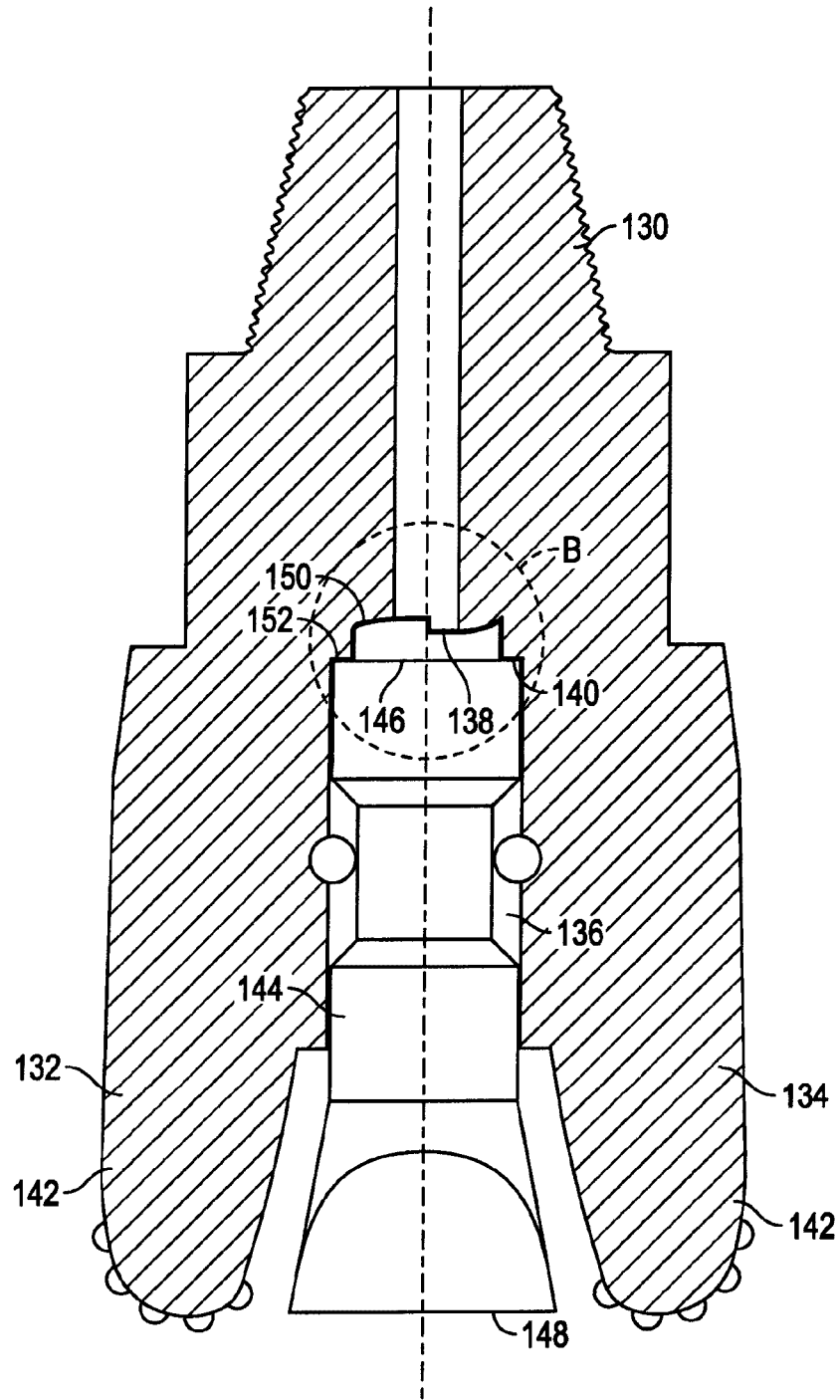

FIG. 10

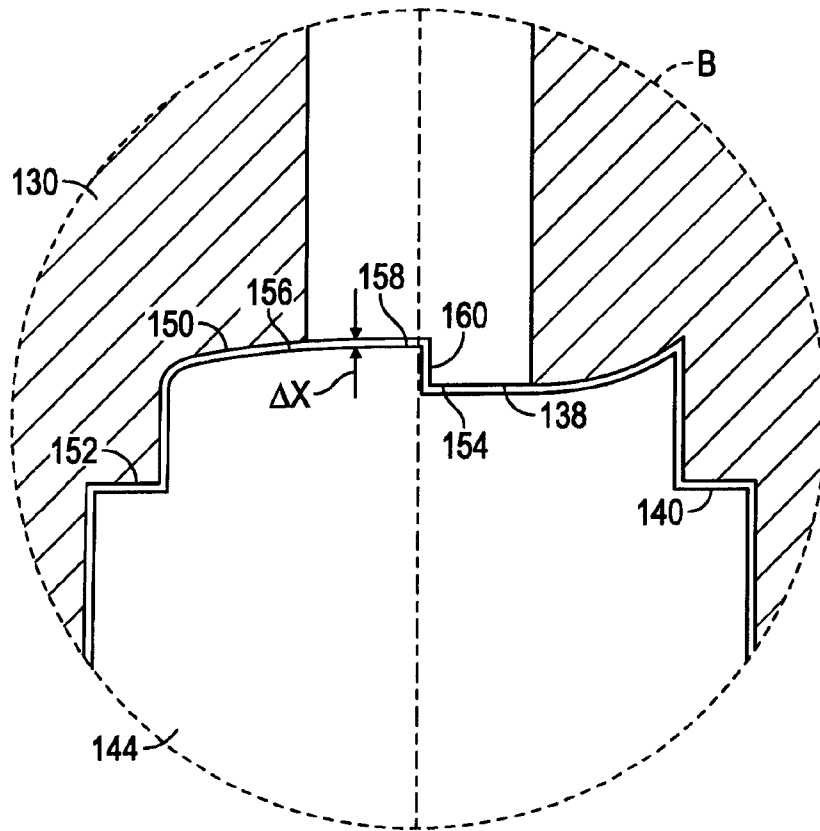

FIG. 11

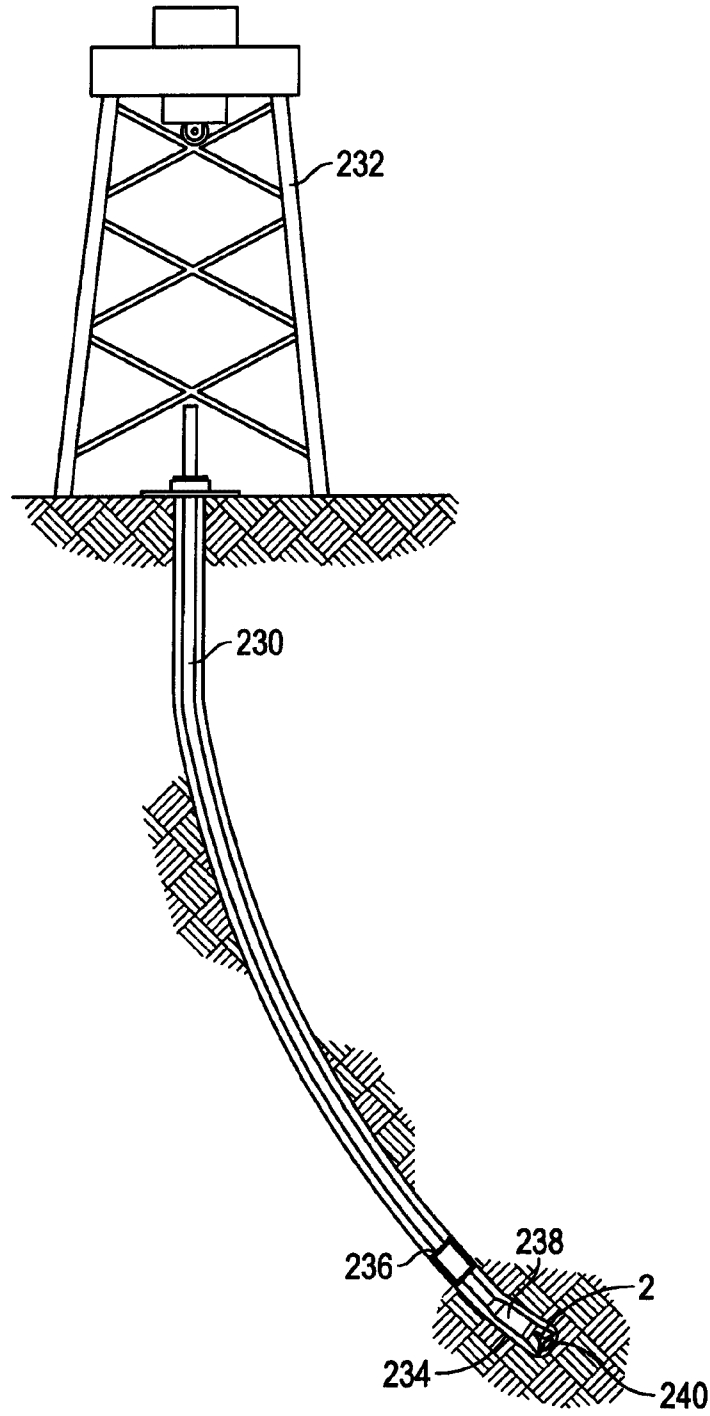

FIG. 12

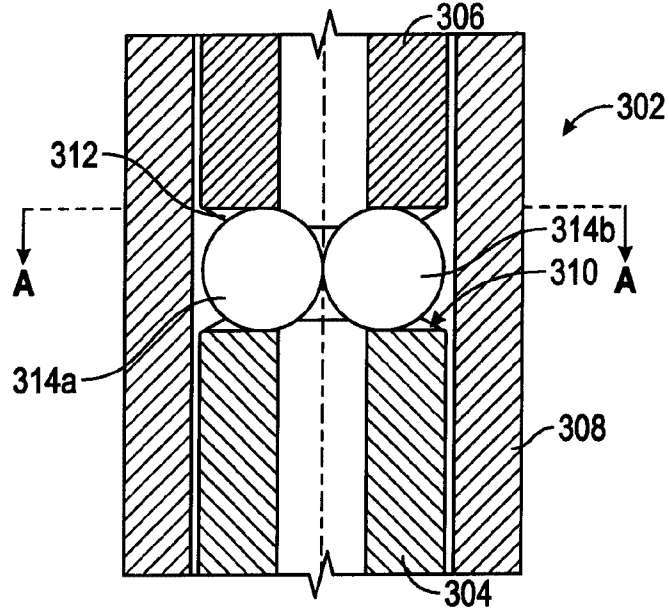

FIG. 13

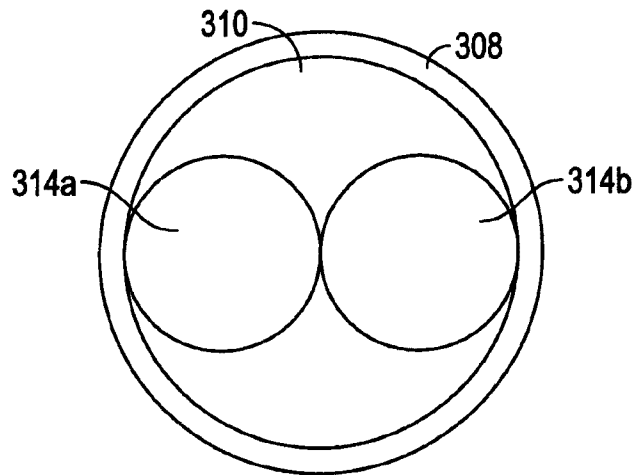

FIG. 14A

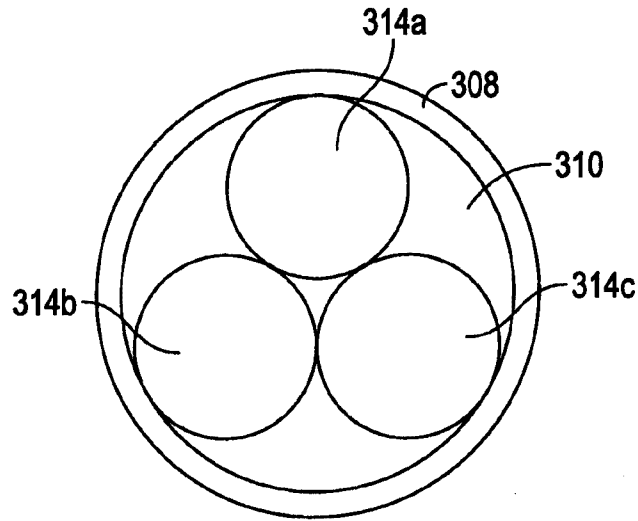

FIG. 14B

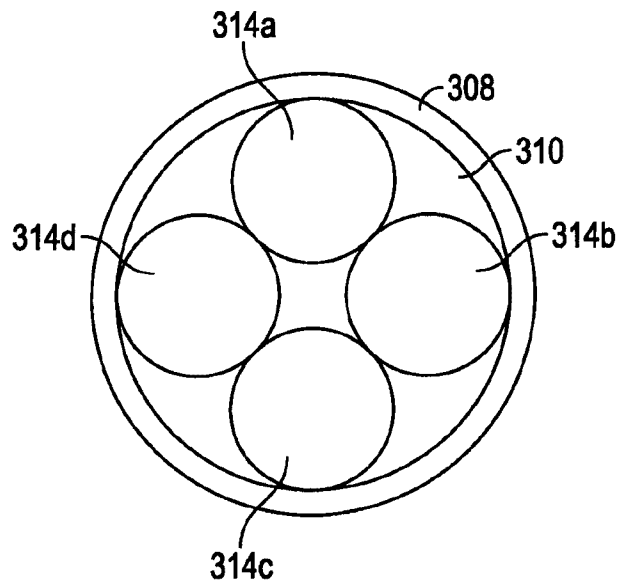

FIG. 14C

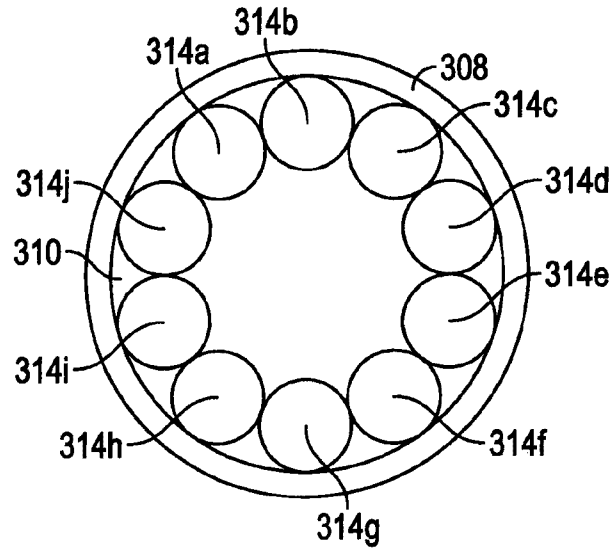

FIG. 14D

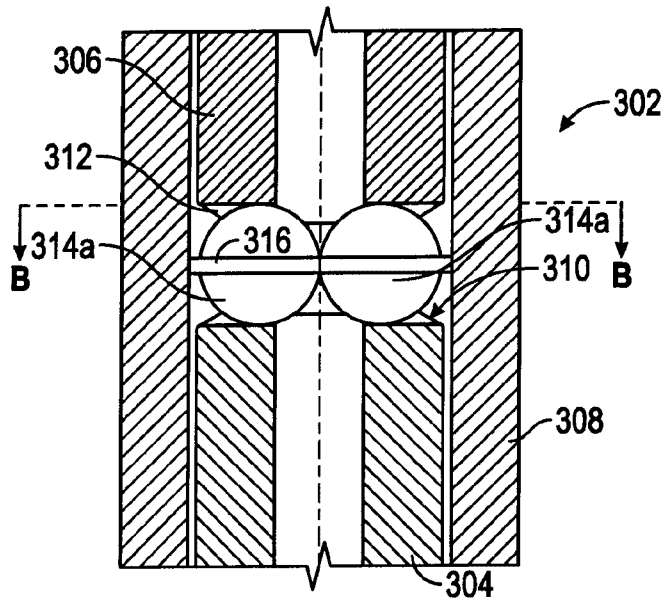

FIG. 15

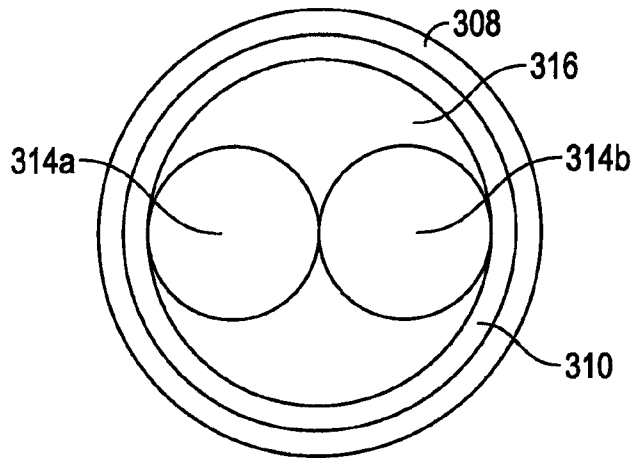

FIG. 16A

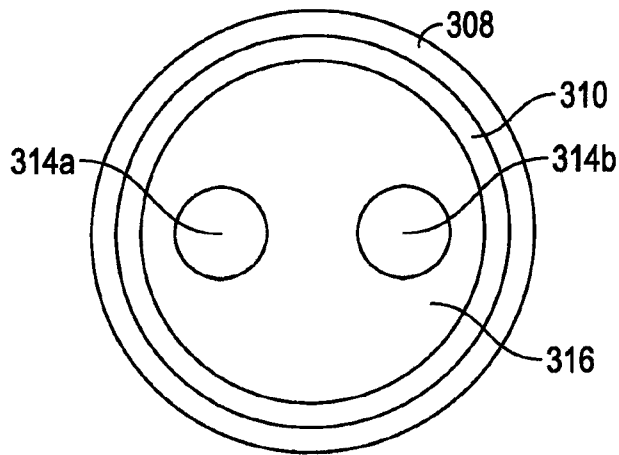

FIG. 16B

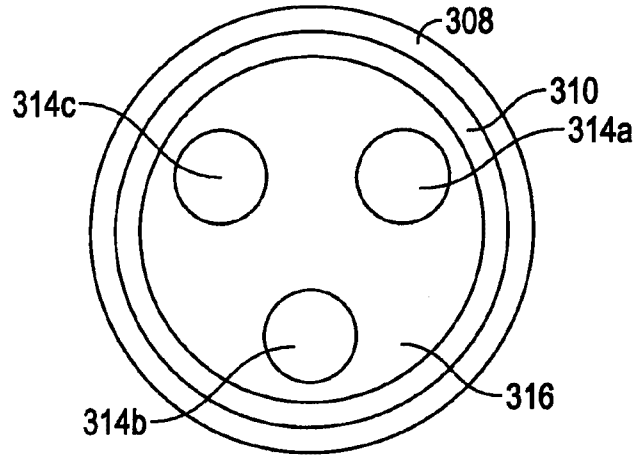

FIG. 16C

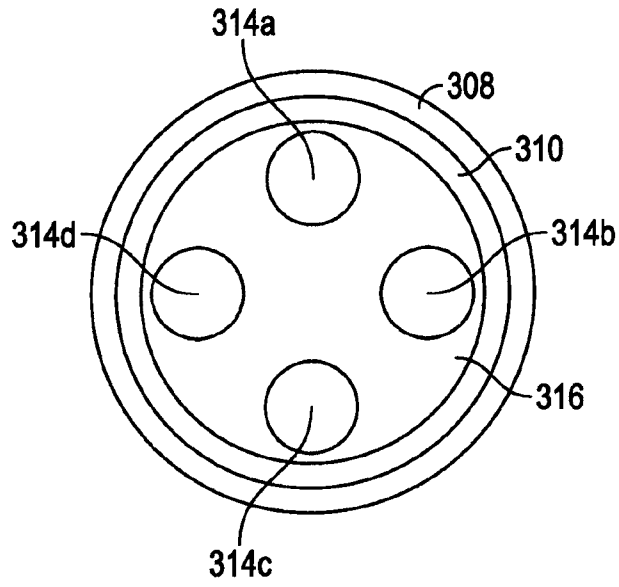

FIG. 16D

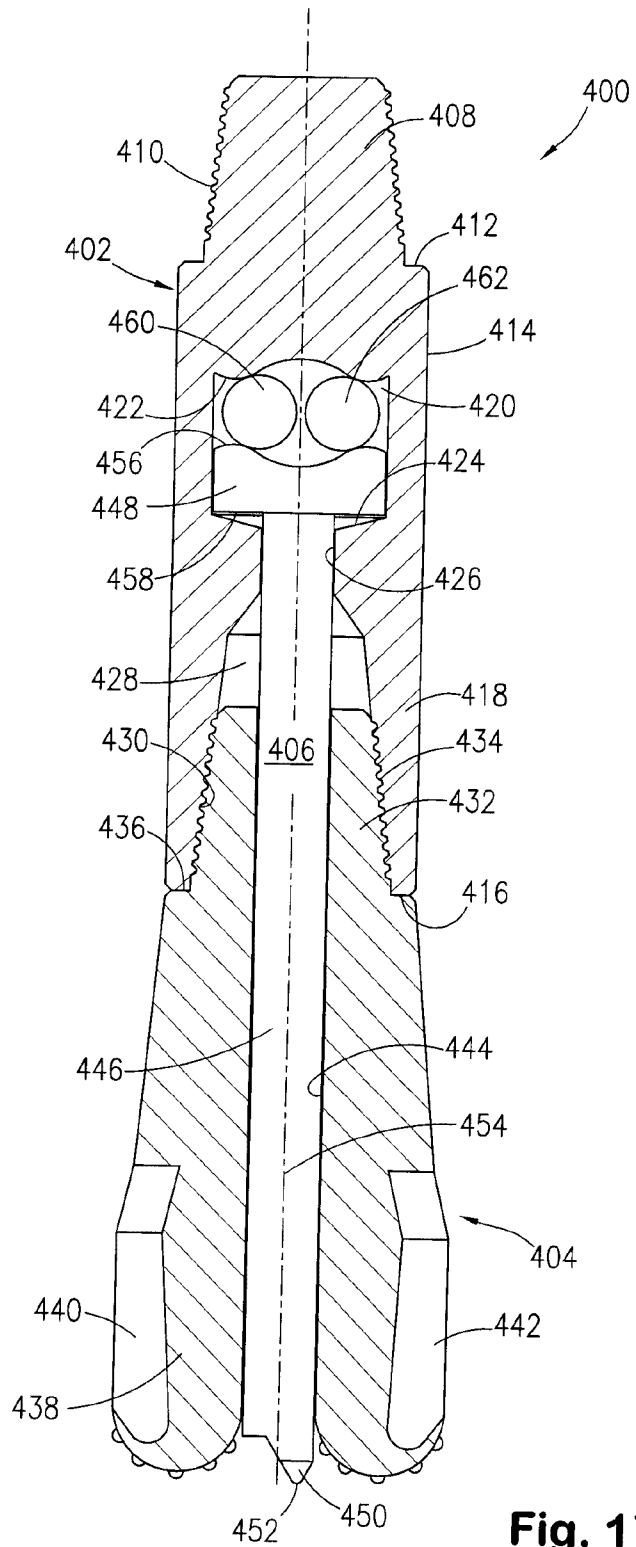

Fig. 17

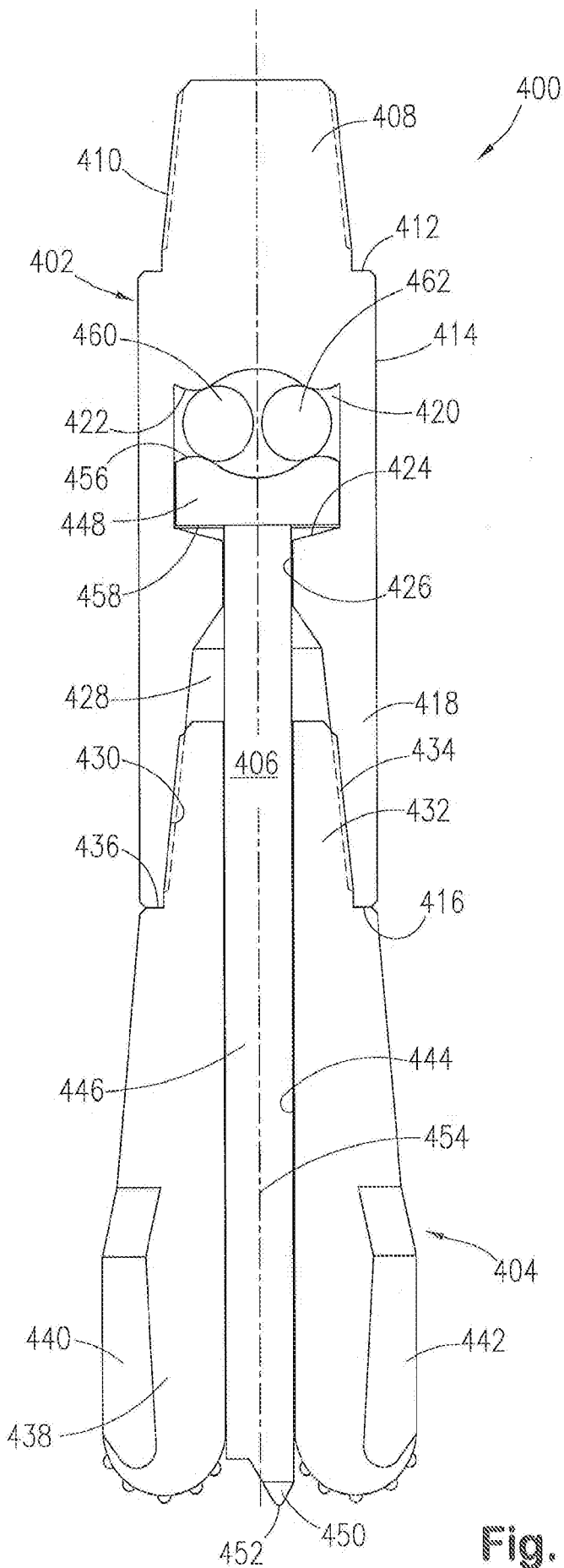

Fig. 17