



(12) **DEMANDE DE BREVET CANADIEN
CANADIAN PATENT APPLICATION**

(13) **A1**

(22) Date de dépôt/Filing Date: 2018/09/17
(41) Mise à la disp. pub./Open to Public Insp.: 2019/04/11
(30) Priorités/Priorities: 2017/10/11 (US62/571042);
2018/05/31 (US15/994609)

(51) Cl.Int./Int.Cl. *E03F 5/04* (2006.01)
(71) Demandeur/Applicant:
INFINITY DRAIN LTD., US
(72) Inventeurs/Inventors:
BRILL, JONATHAN, US;
TRINK, ALAN, US;
RAMKARRAN, BHASNARINE, US
(74) Agent: PERRY + CURRIER

(54) Titre : CORPS DE DRAIN SEMI-CIRCULAIRE ET SYSTEME DE DRAIN LINEAIRE COMPORTANT LEDIT CORPS
(54) Title: SEMI-ROUND DRAIN BODY AND LINEAR DRAIN SYSTEM INCLUDING THE SAME

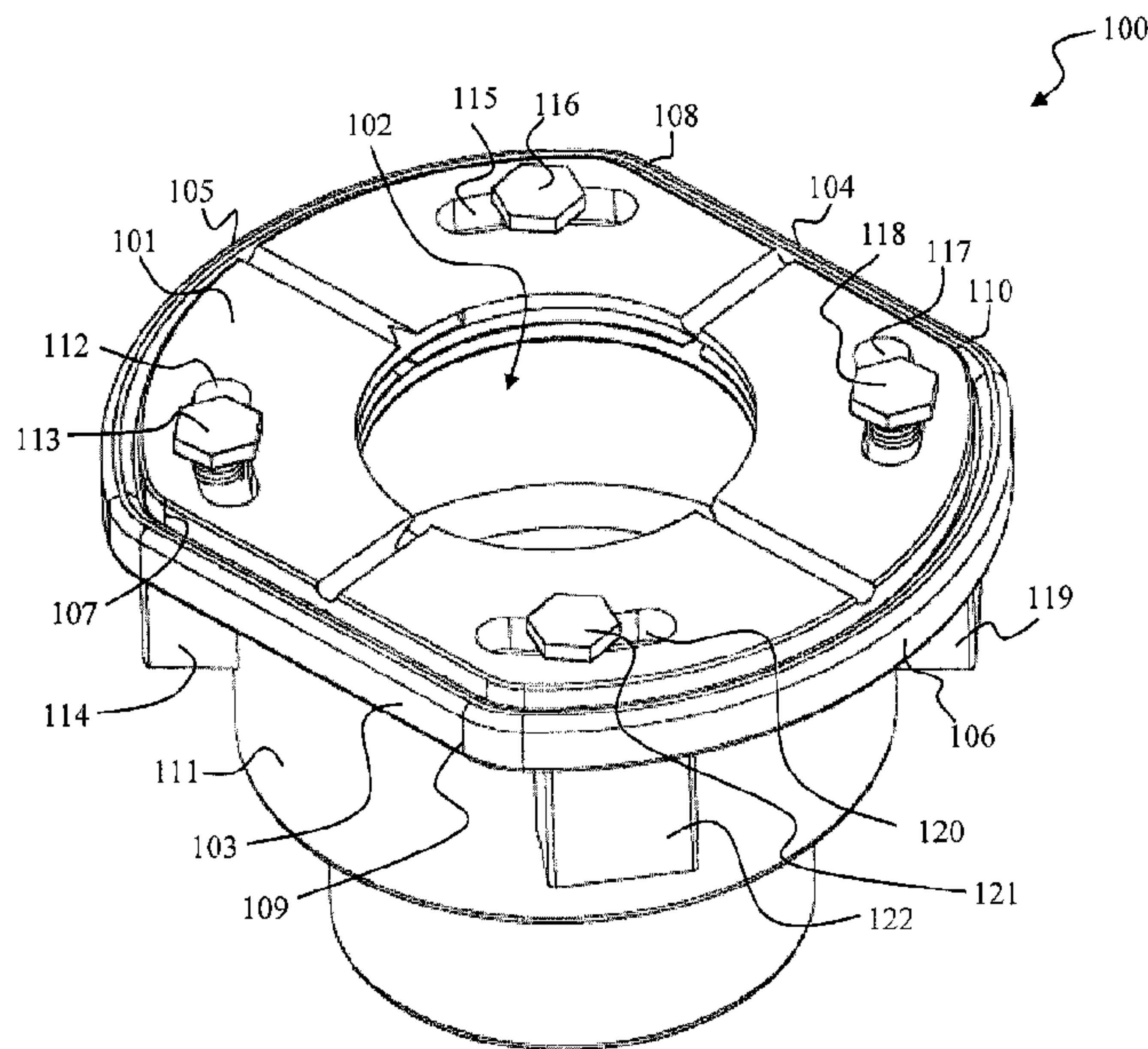

(57) **Abrégé/Abstract:**

A semi-round drain body includes an upper surface and a drain hole extending through the upper surface. The upper surface includes a first straight edge, a second straight edge disposed opposite to the first straight edge, a first curved edge, and a second curved edge disposed opposite to the first curved edge. The drain hole is disposed between the first and second straight edges and between the first and second curved edges. The first curved edge connects a first end of the first straight edge and a first end of the second straight edge to each other, and the second curved edge connects a second end of the first straight edge and a second end of the second straight edge to each other.

ABSTRACT

A semi-round drain body includes an upper surface and a drain hole extending through the upper surface. The upper surface includes a first straight edge, a second straight edge disposed opposite to the first straight edge, a first curved edge, and a second curved edge disposed opposite to the first curved edge. The drain hole is disposed between the first and second straight edges and between the first and second curved edges. The first curved edge connects a first end of the first straight edge and a first end of the second straight edge to each other, and the second curved edge connects a second end of the first straight edge and a second end of the second straight edge to each other.

SEMI-ROUND DRAIN BODY AND LINEAR DRAIN SYSTEM INCLUDING THE SAME

CROSS-REFERENCE TO RELATED APPLICATIONS

This application claims priority to and the benefit of U.S. Provisional Application Serial
5 No. 62/571,042 filed on October 11, 2017 and of U.S. Non-Provisional Application Serial No.
15/994,609 filed on May 31, 2018, the disclosures of which are herein incorporated by reference
in its entirety.

TECHNICAL FIELD

10 Exemplary embodiments of the present invention relate to a semi-round drain body and a
linear drain system including the semi-round drain body.

DISCUSSION OF THE RELATED ART

15 A linear drain system typically includes a round drain body installed in a floor, and a
linear drain channel installed onto the drain body. The linear drain channel may be positioned,
for example, along a structure such as a wall or the threshold of a shower enclosure. Due to the
round shape of the drain body, a limitation may occur in which the round drain body and the
linear drain channel cannot be installed as close to the edge of the structure as desired, as the
round drain body creates a space between the structure and the round drain body, and as a result,
20 between the structure and the linear drain channel installed onto the round drain body. This
limitation may also occur with other types of floor drains (e.g., floor drains other than a linear
drain channel) connected to the round drain body.

SUMMARY

According to an exemplary embodiment of the present invention, a semi-round drain body includes an upper surface and a drain hole extending through the upper surface. The upper surface includes a first straight edge, a second straight edge disposed opposite to the first straight edge, a first curved edge, and a second curved edge disposed opposite to the first curved edge. The drain hole is disposed between the first and second straight edges and between the first and second curved edges. The first curved edge connects a first end of the first straight edge and a first end of the second straight edge to each other, and the second curved edge connects a second end of the first straight edge and a second end of the second straight edge to each other.

According to an exemplary embodiment of the present invention, a linear drain system includes a linear drain channel and a semi-round drain body. The linear drain channel includes a first side, a second side opposing the first side, a third side, and a fourth side opposing the third side. The first side connects a first end of the third side and a first end of the fourth side to each other, and the second side connects a second end of the third side and a second end of the fourth side to each other. The first and second sides are longer than the third and fourth sides. The linear drain channel further includes a lower surface disposed between and connected to the first, second, third, and fourth sides, as well as a drain hole formed in the lower surface. The semi-round drain body is configured to attach to the linear drain channel. The semi-round drain body includes an upper surface and a drain hole extending through the upper surface. The upper surface includes a first straight edge, a second straight edge disposed opposite to the first straight edge, a first curved edge, and a second curved edge. The drain hole of the semi-round drain body is disposed between the first and second straight edges, and between the first and second curved edges. The first curved edge connects a first end of the first straight edge and a first end

of the second straight edge to each other, and the second curved edge connects a second end of the first straight edge and a second end of the second straight edge to each other.

According to an exemplary embodiment of the present invention, a linear drain system includes a linear drain channel and a semi-round drain body. The linear drain channel includes a first side, a second side disposed substantially parallel to the first side, a third side, and a fourth side disposed substantially parallel to the third side. The first and second sides are longer than the third and fourth sides. The semi-round drain body is configured to attach to the linear drain channel, and includes an upper surface. The upper surface includes a first straight edge, a second straight edge disposed substantially parallel to the first straight edge, a first curved edge, and a second curved edge disposed opposite to the first curved edge.

BRIEF DESCRIPTION OF THE DRAWINGS

The above and other features of the present invention will become more apparent by describing in detail exemplary embodiments thereof with reference to the accompanying drawings, in which:

FIG. 1 is a perspective view of a semi-round drain body according to an exemplary embodiment of the present invention.

FIG. 2 is a top plan view of the semi-round drain body illustrated in FIG. 1 according to an exemplary embodiment of the present invention.

FIG. 3 is a side view of the semi-round drain body illustrated in FIG. 1 according to an exemplary embodiment of the present invention.

FIG. 4 is a bottom view of the semi-round drain body illustrated in FIG. 1 according to an exemplary embodiment of the present invention.

FIG. 5 is a side view of the semi-round drain body illustrated in FIG. 1 according to an exemplary embodiment of the present invention.

FIG. 6 is a perspective view of the semi-round drain body illustrated in FIG. 1 with a clamping plate removed according to an exemplary embodiment of the present invention.

FIG. 7 is a top plan view of a linear drain system according to an exemplary embodiment of the present invention.

FIG. 8 is a perspective exploded view of the linear drain system illustrated in FIG. 6 according to an exemplary embodiment of the present invention.

FIG. 9 is a perspective view of the linear drain system illustrated in FIG. 6 according to an exemplary embodiment of the present invention.

DETAILED DESCRIPTION OF THE EXEMPLARY EMBODIMENTS

Exemplary embodiments of the present invention will be described more fully hereinafter with reference to the accompanying drawings. Like reference numerals may refer to like elements throughout the accompanying drawings.

Hereinafter, spatially relative terms, such as “beneath”, “below”, “lower”, “under”, “above”, “upper”, etc., may be used herein for ease of description to describe one element or feature’s relationship to another element(s) or feature(s) as illustrated in the figures. It will be understood that the spatially relative terms are intended to encompass different orientations of the device in use or operation in addition to the orientation depicted in the figures. For example, if the device in the figures is turned over, elements described as “below” or “beneath” or “under” other elements or features would then be oriented “above” the other elements or features. Thus,

the exemplary terms “below” and “under” can encompass both an orientation of above and below.

It will further be understood that the terms “first,” “second,” “third,” etc. are used herein to distinguish one element from another, and the elements are not limited by these terms. Thus, a “first” element in an exemplary embodiment may be described as a “second” element in another exemplary embodiment. In addition, when two or more values (e.g., a length, a width, a height, a distance, etc.) are described as being substantially the same as or about equal to each other, it is to be understood that the elements or values are identical to each other, indistinguishable from each other, or distinguishable from each other but functionally the same as each other as would be understood by a person having ordinary skill in the art.

FIG. 1 is a perspective view of a semi-round drain body according to an exemplary embodiment of the present invention. FIG. 2 is a top plan view of the semi-round drain body illustrated in FIG. 1 according to an exemplary embodiment of the present invention. FIG. 3 is a side view of the semi-round drain body illustrated in FIG. 1 according to an exemplary embodiment of the present invention. For example, FIG. 3 is side view taken from a side corresponding to a straight edge of an upper surface of the semi-round drain body illustrated in FIG. 1. FIG. 4 is a bottom view of the semi-round drain body illustrated in FIG. 1 according to an exemplary embodiment of the present invention. FIG. 5 is a side view of the semi-round drain body illustrated in FIG. 1 according to an exemplary embodiment of the present invention. For example, FIG. 5 is side view taken from a side corresponding to a curved edge of the upper surface of the semi-round drain body illustrated in FIG. 1. FIG. 6 is a perspective view of the semi-round drain body illustrated in FIG. 1 with a clamping plate removed according to an exemplary embodiment of the present invention.

Herein, a semi-round drain body may also be referred to as a semi-round clamp-down drain body. The semi-round drain body according to exemplary embodiments of the present invention may be, for example, a cast-iron semi-round drain body. Further, in exemplary
5 embodiments, the semi-round drain body may be formed of, for example, acrylonitrile butadiene styrene (ABS) plastic, or polyvinyl chloride (PVC). However, the material used to form the semi-round drain body is not limited thereto.

Referring to FIGs. 1 to 6, in an exemplary embodiment of the present invention, a semi-round drain body **100** includes an upper surface **123** having a drain hole **102** that extends through
the upper surface **123**.

The upper surface **123** of the semi-round drain body **100** includes a first straight edge
10 **103**, a second straight edge **104**, a first curved edge **105**, and a second curved edge **106**. The first straight edge **103** and the second straight edge **104** are disposed opposite to each other, with the drain hole **102** disposed therebetween. The first straight edge **103** and the second straight edge
15 **104** are disposed opposite to each other and are substantially parallel to each other. For example, the first straight edge **103** and the second straight edge **104** may be exactly parallel to each other, or approximately parallel to each other within a measurement error as would be understood by a person having ordinary skill in the art. The first curved edge **105** and the second curved edge
20 **106** are disposed opposite to each other, with the drain hole **102** disposed therebetween. The first curved edge **105** connects a first end **107** of the first straight edge **103** and a first end **108** of the second straight edge **104** to each other. The second curved edge **106** connects a second end
109 of the first straight edge **103** and a second end **110** of the second straight edge **104** to each other.

The semi-round drain body **100** further includes a base portion **111** connected to and extending from a bottom side of the upper surface **123**. Together, the drain hole **102** and the base portion **111** form a through hole that extends through the entirety of the semi-round drain body **100**. Water (or any other liquid) may pass through the through hole formed by the drain hole **102** and the base portion **111** to be drained through the semi-round drain body **100**. The base portion **111** may have a circular shape that is shaped and dimensioned to connect to, for example, a pipe that the semi-round drain body **100** is to be connected to, allowing water (or any other liquid) to be drained through the semi-round drain body **100** and the connected pipe.

In an exemplary embodiment, a clamping plate **101** is attached to the upper surface **123** using fasteners (e.g., screws, bolts, etc.). A sealing material (e.g., a shower pan liner) may be disposed between the clamping plate **101** and the semi-round drain body **100**, thereby creating a waterproof seal when the clamping plate **101** is clamped down onto the semi-round drain body **100** with the sealing material (e.g., the shower pan liner) disposed therebetween.

As shown in FIG. 6, in an exemplary embodiment, the first and second straight edges **103** and **104** and the first and second curved edges **105** and **106** of the upper surface **123** extend upward from the upper surface **123**, forming a lip. The clamping plate **101** may be shaped and dimensioned to fit within this lip (see, e.g., FIGs. 1 and 6). Thus, similar to the upper surface **123** of the semi-round drain body **100**, the clamping plate **101** includes first and second straight edges and first and second curved edges, which respectively correspond to the first and second straight edges **103** and **104** and the first and second curved edges **105** and **106** of the upper surface **123**. The clamping plate **101** is sized such that it fits within the lip of the upper surface **123** of the semi-round drain body **100** formed by the first and second straight edges **103** and **104** and the first and second curved edges **105** and **106**.

In an exemplary embodiment, a first fastener opening **112**, a second fastener opening **115**, a third fastener opening **117**, and a fourth fastener opening **120** are formed in the clamping plate **101**. The first to fourth fastener openings **112**, **115**, **117** and **120** are shaped and dimensioned to respectively receive a first fastener **113**, a second fastener **116**, a third fastener **118**, and a fourth fastener **121** to secure the clamping plate **101** to the semi-round drain body **100**. First to fourth fastener receiving cavities **114**, **117**, **119** and **122** are disposed below and extend from the bottom side of the upper surface **123**. The first to fourth fastener receiving cavities **114**, **117**, **119** and **122** are respectively aligned with the first to fourth fastener openings **112**, **115**, **117** and **120** when the clamping plate **101** is attached to the upper surface **123**. The first to fourth fastener receiving cavities **114**, **117**, **119** and **122** are respectively configured to secure the first to fourth fasteners **113**, **116**, **118**, and **121** therein. For example, when the first to fourth fasteners are threaded fasteners (e.g., a threaded bolt or screw), the fastener receiving cavities may be correspondingly threaded to secure the fasteners therein. To secure the clamping plate **101** to the semi-round drain body **100**, the first to fourth fasteners **113**, **116**, **118**, and **121** are respectively inserted through the first to fourth fastener openings **112**, **115**, **117** and **120** formed in the clamping plate **101**, through fastener holes **124** (see FIG. 6) formed in the upper surface **123** of the semi-round drain body **100**, and into the first to fourth fastener receiving cavities **114**, **117**, **119** and **122**.

In an exemplary embodiment, the first fastener receiving cavity **114** is disposed in an area between the first end **107** of the first straight edge **103** and the center of the first curved edge **105**, the second fastener receiving cavity **117** is disposed in an area between the first end **108** of the second straight edge **104** and the center of the first curved edge **105**, the third fastener receiving cavity **119** is disposed in an area between the second end **110** of the second straight

edge **104** and the center of the second curved edge **106**, and the fourth fastener receiving cavity **122** is disposed in an area between the second end **109** of the first straight edge **103** and the center of the second curved edge **106**. In addition, the first and second fastener receiving cavities **114** and **117** are disposed between an outer circumference **401** of the base portion **111** and the first curved edge **105**, and the third and fourth fastener receiving cavities **119** and **122** are disposed between the outer circumference **401** of the base portion **111** and the second curved edge **106**.

The semi-round drain body **100** according to exemplary embodiments of the present invention provides improvements over a conventional drain body, which is fully round. For example, because a conventional drain body is fully round, a limitation may occur in which the conventional drain body cannot be installed as close to the edge of a structure such as, for example, a wall or the threshold to a shower enclosure, as desired. Due to the semi-round shape of the semi-round drain body **100** according to exemplary embodiments of the present invention, the semi-round drain body **100** may be placed closer to such a structure compared to a conventional drain body. For example, one of the first and second straight edges **103** and **104** of the semi-round drain body **100** may be placed against such a structure, whereas due to the fully round shape of a conventional drain body, the conventional drain body cannot be placed as close to such a structure as compared to the semi-round drain body **100**. In addition, due to the semi-round shape of the semi-round drain body **100**, the overall size and footprint of the semi-round drain body **100** may be smaller than that of a comparable conventional fully round drain body. The ability to install the semi-round drain body **100** closer to a structure such as a wall or the threshold to a shower enclosure, as well as the reduced footprint of the semi-round drain body **100** compared to that of a conventional drain body, may provide improvements relating to the

efficiency of drainage in certain environments, and may also provide the benefit of giving an installer more options regarding the placement of the semi-round drain body **100**.

Further, the positions of the first to fourth receiving cavities **114**, **117**, **119** and **122** as described above also results in allowing for the semi-round drain body **100** to be placed closer to a structure such as a wall or the threshold to a shower enclosure. For example, by positioning the first to fourth receiving cavities **114**, **117**, **119** and **122** in areas between ends of the straight edges and center portions of the curved edges, and between the outer circumference **401** of the base portion **111** and the curved edges, as described above, the first to fourth receiving cavities **114**, **117**, **119** and **122** allow for the clamping plate **101** to be securely attached to the upper surface **123** while not interfering with the ability to place the first and second straight edges **103** and **104** closely against the structure.

According to exemplary embodiments of the present invention, the semi-round drain body **100** may be used in a linear drain system in conjunction with a linear drain channel, as described below with reference to FIGs. 7-9.

A linear drain channel is an elongated drain channel that may be positioned, for example, along a wall or along the threshold of a shower enclosure. A linear drain channel is installed onto a drain body that is installed in a floor. Exemplary embodiments of the present invention may be utilized with a variety of linear drain systems. For example, exemplary embodiments may be utilized with a linear drain system having a wedge wire system, a perforated drain system, or a tile insert system. However, exemplary embodiments are not limited thereto.

FIG. 7 is a top plan view of a linear drain system including a linear drain channel according to an exemplary embodiment of the present invention. FIG. 8 is a perspective exploded view of the linear drain system illustrated in FIG. 7 according to an exemplary

embodiment of the present invention. FIG. 9 is a perspective view of the linear drain system illustrated in FIG. 7 according to an exemplary embodiment of the present invention.

Referring to Figs. 7-9, in an exemplary embodiment, a linear drain system **700** includes a linear drain channel **701** and the semi-round drain body **100**. The linear drain channel **701** includes a first side **702**, a second side **703** opposing the first side **702**, a third side **704**, and a fourth side **705** opposing the third side **704**. The first and second sides **702** and **703** are substantially parallel to each other. For example, the first and second sides **702** and **703** may be exactly parallel to each other, or approximately parallel to each other within a measurement error as would be understood by a person having ordinary skill in the art. The third and fourth sides **704** and **705** are substantially parallel to each other. For example, the third and fourth sides **704** and **705** may be exactly parallel to each other, or approximately parallel to each other within a measurement error as would be understood by a person having ordinary skill in the art. As shown in FIGs. 7-9, the first side **702** connects a first end **706** of the third side **704** and a first end **707** of the fourth side **705** to each other, and the second side **703** connects a second end **708** of the third side **704** and a second end **709** of the fourth side **705** to each other. The linear drain channel **701** is an elongated drain channel. For example, the first and second sides **702** and **703** are longer than the third and fourth sides **704** and **705**.

A lower surface **710** is disposed between and connected to the first to fourth sides **702** – **705**. The first to fourth sides **702** – **705** extend upward from the lower surface **710**, thus forming a drain channel. A drain hole **711**, through which water (or any other liquid) may be drained, is formed in the lower surface **710**.

The semi-round drain body **100** illustrated in FIGs. 7-9 is the same semi-round drain body **100** described in detail with reference to FIGs. 1-6. Thus, for convenience of explanation,

a further description of elements and functions of the semi-round drain body **100** previously described with reference to FIGs. 1-6 may be omitted herein.

The semi-round drain body **100** is configured to attach to the linear drain channel **701**. For example, in an exemplary embodiment, an outlet **712** attaches the semi-round drain body **100** to the linear drain channel **701**. The outlet **712** and the drain hole **102** of the semi-round drain body **100** may both be threaded, and the outlet **712** may attach to the semi-round drain body **100** via a threaded connection. For example, the outer surface of the outlet **712** may be threaded, the inner surface of the drain hole **102** may be threaded, and the outlet **712** may be shaped and dimensioned to fit within the drain hole **102** to be connected to the semi-round drain body **100** via a threaded connection. When the outlet **712** attaches the semi-round drain body **100** to the linear drain channel **701**, the drain hole **711** of the linear drain channel **701**, an opening of the outlet **712**, and the drain hole **102** of the semi-round drain body **100** form a through hole (e.g., a complete opening) that allows water (or any other liquid) to be drained through the linear drain channel **701**, the outlet **712**, and the semi-round drain body **100** and into a pipe connected to the semi-round drain body **100**.

The linear drain channel **701** and the outlet **712** may be formed of, for example, stainless steel. However, the material of the linear drain channel **701** and the outlet **712** is not limited thereto.

In an exemplary embodiment, when the semi-round drain body **100** is utilized with the linear drain channel **701**, the semi-round drain body **100** is installed into a floor to connect to a pipe, the outlet **712** is inserted into the drain hole **102** of the semi-round drain body **100** to be attached to the semi-round drain body **100**, as described above, and the linear drain channel **701** is installed in the floor and onto the semi-round drain body **100**, as shown in FIGs. 8 and 9. For

example, the linear drain channel **701** may include a protruding portion **713** (see FIG. 8) extending from the drain hole **711** that is shaped and dimensioned to be placed into the opening of the outlet **712**. The linear drain channel **701** may be installed into the floor by creating a mortar bed (also referred to as a cement bed or a mud bed) that extends the length of the linear drain channel **701**, and by backfilling the underside of the linear drain channel **701**.

As described above, due to the semi-round shape of the semi-round drain body **100** according to exemplary embodiments of the present invention, the semi-round drain body **100** may be placed closer to a structure such as, for example, a wall or the threshold to a shower enclosure, compared to a conventional fully round drain body. When used in the linear drain system **700** with the linear drain channel **701**, the semi-round drain body **100** provides additional improvements compared to a conventional linear drain system. For example, since the semi-round drain body **100** may be placed closer to such a structure, the linear drain channel **701** installed onto the semi-round drain body **100** may also be placed closer to the structure. That is, the linear drain channel **701** in the linear drain system **700** according exemplary embodiments may be placed closer to a structure such as a wall or the threshold to a shower enclosure relative to a linear drain channel in a conventional linear drain system due to the semi-round shape of the semi-round drain body **100**. In addition, due to the semi-round shape of the semi-round drain body **100**, the width of the linear drain channel **701** between the first and second sides **702** and **703** may be smaller than the width of a conventional linear drain channel used with a conventional fully round drain body. Thus, exemplary embodiments allow for a smaller linear drain channel **701**. As a result, exemplary embodiments of the linear drain system **700** provide improvements relating to the efficiency of drainage in certain environments, and may also

provide the benefit of giving an installer more options regarding the placement of the linear drain channel **701**.

For example, according to exemplary embodiments, the distance between the first side **702** of the linear drain channel **701** and the second side **703** of the linear drain channel **701** is about equal to the distance between the first straight edge **103** of the semi-round drain body **100** and the second straight edge **104** of the semi-round drain body **100**. That is, the width of the linear drain channel **701** measured from the first side **702** to the second side **703** is about equal to the width of the semi-round drain body **100** measured from the first straight edge **103** to the second straight edge **104**. As a result, the linear drain channel **701** may be installed closer to a structure such as, for example, a wall or a threshold to a shower enclosure compared to a conventional linear drain channel in a conventional linear drain system that utilizes a conventional fully round drain body.

In exemplary embodiments, when the semi-round drain body **100** is attached to the linear drain channel **701**, the first side **702** of the linear drain channel **701** is substantially aligned with the first straight edge **103** of the semi-round drain body **100**, and/or the second side **703** of the linear drain channel **701** is substantially aligned with the second straight edge **104** of the semi-round drain body **100**. As a result, the linear drain channel **701** may be installed closer to a structure such as, for example, a wall or a threshold to a shower enclosure compared to a conventional linear drain channel in a conventional linear drain system that utilizes a conventional fully round drain body.

In exemplary embodiments, when the semi-round drain body **100** is attached to the linear drain channel **701**, the first straight edge **103** of the semi-round drain body **100** does not extend beyond the first side **702** of the linear drain channel in a top plan view, and/or the second straight

edge **104** of the semi-round drain body **100** does not extend beyond the second side **703** of the linear drain channel **701** in a top plan view. As a result, the linear drain channel **701** may be installed closer to a structure such as, for example, a wall or a threshold to a shower enclosure compared to a conventional linear drain channel in a conventional linear drain system that utilizes a conventional fully round drain body.

The above-described configurations can be seen, for example, in FIG. 7, in which the first and second straight edges **103** and **104** of the semi-round drain body **100** are not visible in the top plan view due to them being covered by the first and second sides **702** and **703** of the linear drain channel **701**, as well as in FIGs. 8 and 9.

In addition to allowing for a linear drain channel to be placed closer to a structure such as a wall or the threshold of a shower enclosure, the semi-round shape of the semi-round drain body **100** according to exemplary embodiments of the present invention allows for any type of floor drain connected thereto to be placed closer to such a structure as compared to a conventional drain body.

Having described exemplary embodiments for a semi-round drain body and a linear drain system including the same, it is noted that modifications and variations can be made by persons skilled in the art in light of the above teachings. It is therefore to be understood that changes may be made in exemplary embodiments of the invention, which are within the scope and spirit of the invention as defined by the appended claims. Having thus described the invention with the details and particularity required by the patent laws, what is claimed and desired protected by Letters Patent is set forth in the appended claims.

What is claimed is:

1. A semi-round drain body, comprising:

an upper surface; and

a drain hole extending through the upper surface, wherein the upper surface comprises:

5 a first straight edge;

a second straight edge disposed opposite to the first straight edge, wherein the drain hole is disposed between the first and second straight edges;

a first curved edge; and

10 a second curved edge disposed opposite to the first curved edge, wherein the drain hole is disposed between the first and second curved edges,

wherein the first curved edge connects a first end of the first straight edge and a first end of the second straight edge to each other, and the second curved edge connects a second end of the first straight edge and a second end of the second straight edge to each other.

15 2. The semi-round drain body of claim 1, further comprising:

a base portion connected to a bottom side of the upper surface, wherein the drain hole and the base portion form a through hole extending through the semi-round drain body.

3. The semi-round drain body of claim 2, wherein the base portion has a circular shape.

20 4. The semi-round drain body of claim 3, further comprising:

a clamping plate configured to attach to the upper surface;

a fastener opening formed in the clamping plate, wherein the fastener opening is shaped and dimensioned to receive a fastener; and

a fastener receiving cavity disposed below and extending from the bottom side of the upper surface, wherein the fastener receiving cavity is aligned with the fastener opening when the clamping plate is attached to the upper surface, and the fastener receiving cavity is configured to secure the fastener,

wherein the fastener receiving cavity is disposed in an area between the first end of the first straight edge and a center of the first curved edge.

5. The semi-round drain body of claim 4, wherein the fastener receiving cavity is disposed between an outer circumference of the base portion and the first curved edge.

6. The semi-round drain body of claim 4, wherein the fastener is a screw or a bolt.

7. The semi-round drain body of claim 3, further comprising:

a clamping plate configured to attach to the upper surface;

a first fastener opening formed in the clamping plate, wherein the first fastener opening is shaped and dimensioned to receive a first fastener;

a first fastener receiving cavity disposed below and extending from the bottom side of the upper surface, wherein the first fastener receiving cavity is aligned with the first fastener opening when the clamping plate is attached to the upper surface, is configured to secure the first fastener, and is disposed in a first area between the first end of the first straight edge and a center of the first curved edge;

a second fastener opening formed in the clamping plate, wherein the second fastener opening is shaped and dimensioned to receive a second fastener;

5 a second fastener receiving cavity disposed below and extending from the bottom side of the upper surface, wherein the second fastener receiving cavity is aligned with the second fastener opening when the clamping plate is attached to the upper surface, is configured to secure the second fastener, and is disposed in a second area between the first end of the second straight edge and the center of the first curved edge;

a third fastener opening formed in the clamping plate, wherein the third fastener opening is shaped and dimensioned to receive a third fastener;

10 a third fastener receiving cavity disposed below and extending from the bottom side of the upper surface, wherein the third fastener receiving cavity is aligned with the third fastener opening when the clamping plate is attached to the upper surface, is configured to secure the third fastener, and is disposed in a third area between the second end of the second straight edge and a center of the second curved edge; and

15 a fourth fastener opening formed in the clamping plate, wherein the fourth fastener opening is shaped and dimensioned to receive a fourth fastener; and

a fourth fastener receiving cavity disposed below and extending from the bottom side of the upper surface, wherein the fourth fastener receiving cavity is aligned with the fourth fastener opening when the clamping plate is attached to the upper surface, is configured to secure the
20 fourth fastener, and is disposed in a fourth area between the second end of the first straight edge and the center of the second curved edge.

8. The semi-round drain body of claim 7, wherein the first and second fastener receiving cavities are disposed between an outer circumference of the base portion and the first curved edge, and the third and fourth fastener receiving cavities are disposed between the outer circumference of the base portion and the second curved edge.

5

9. The semi-round drain body of claim 8, wherein the first, second, third, and fourth fasteners are screws or bolts.

10. A linear drain system, comprising:

a linear drain channel, comprising:

a first side, a second side opposing the first side, a third side, and a fourth side opposing the third side,

wherein the first side connects a first end of the third side and a first end of the fourth side to each other, and the second side connects a second end of the third side and a second end of the fourth side to each other,

wherein the first and second sides are longer than the third and fourth sides;

a lower surface disposed between and connected to the first, second, third, and fourth sides; and

a drain hole formed in the lower surface; and

a semi-round drain body configured to attach to the linear drain channel, comprising:

an upper surface; and

a drain hole extending through the upper surface, wherein the upper surface comprises:

a first straight edge;

a second straight edge disposed opposite to the first straight edge, wherein the drain hole of the semi-round drain body is disposed between the first and second straight edges;

5 a first curved edge; and

a second curved edge disposed opposite to the first curved edge, wherein the drain hole of the semi-round drain body is disposed between the first and second curved edges,

10 wherein the first curved edge connects a first end of the first straight edge and a first end of the second straight edge to each other, and the second curved edge connects a second end of the first straight edge and a second end of the second straight edge to each other.

15 11. The linear drain system of claim 10, wherein a distance between the first side of the linear drain channel and the second side of the linear drain channel is about equal to a distance between the first straight edge of the semi-round drain body and the second straight edge of the semi-round drain body.

20 12. The linear drain system of claim 10, wherein, when the semi-round drain body is attached to the linear drain channel, the first side of the linear drain channel is substantially aligned with the first straight edge of the semi-round drain body.

13. The linear drain system of claim 10, wherein, when the semi-round drain body is attached to the linear drain channel, the first straight edge of the semi-round drain body does not extend beyond the first side of the linear drain channel.

5 14. The linear drain system of claim 10, further comprising:
an outlet,
wherein the outlet attaches the semi-round drain body to the linear drain channel,
wherein the drain hole of the linear drain channel, the drain hole of the semi-round drain
10 body, and the outlet form a through hole.

15 15. The linear drain system of claim 10, wherein the semi-round drain body further
comprises:

a clamping plate configured to attach to the upper surface;
a fastener opening formed in the clamping plate, wherein the fastener opening is shaped
15 and dimensioned to receive a fastener; and
a fastener receiving cavity disposed below and extending from a bottom side of the upper
surface, wherein the fastener receiving cavity is aligned with the fastener opening when the
clamping plate is attached to the upper surface, and the fastener receiving cavity is configured to
secure the fastener,

20 wherein the fastener receiving cavity is disposed in an area between the first end of the
first straight edge and a center of the first curved edge.

16. A linear drain system, comprising:

a linear drain channel, comprising:

a first side;

a second side disposed substantially parallel to the first side;

a third side; and

5 a fourth side disposed substantially parallel to the third side,

wherein the first and second sides are longer than the third and fourth sides; and

a semi-round drain body configured to attach to the linear drain channel, comprising:

an upper surface comprising:

a first straight edge;

10 a second straight edge disposed substantially parallel to the first straight
edge;

a first curved edge; and

a second curved edge disposed opposite to the first curved edge.

15 17. The linear drain system of claim 16, wherein a distance between the first side of the
linear drain channel and the second side of the linear drain channel is about equal to a distance
between the first straight edge of the semi-round drain body and the second straight edge of the
semi-round drain body.

20 18. The linear drain system of claim 16, wherein, when the semi-round drain body is
attached to the linear drain channel, the first side of the linear drain channel is substantially
aligned with the first straight edge of the semi-round drain body.

19. The linear drain system of claim 16, wherein, when the semi-round drain body is attached to the linear drain channel, the first straight edge of the semi-round drain body does not extend beyond the first side of the linear drain channel.

5 20. The linear drain system of claim 16, wherein the semi-round drain body further comprises:

 a clamping plate configured to attach to the upper surface;

 a fastener opening formed in the clamping plate, wherein the fastener opening is shaped and dimensioned to receive a fastener; and

10 a fastener receiving cavity disposed below and extending from a bottom side of the upper surface, wherein the fastener receiving cavity is aligned with the fastener opening when the clamping plate is attached to the upper surface, and the fastener opening is configured to secure the fastener,

 wherein the fastener receiving cavity is disposed in an area between a first end of the first
15 straight edge and a center of the first curved edge.

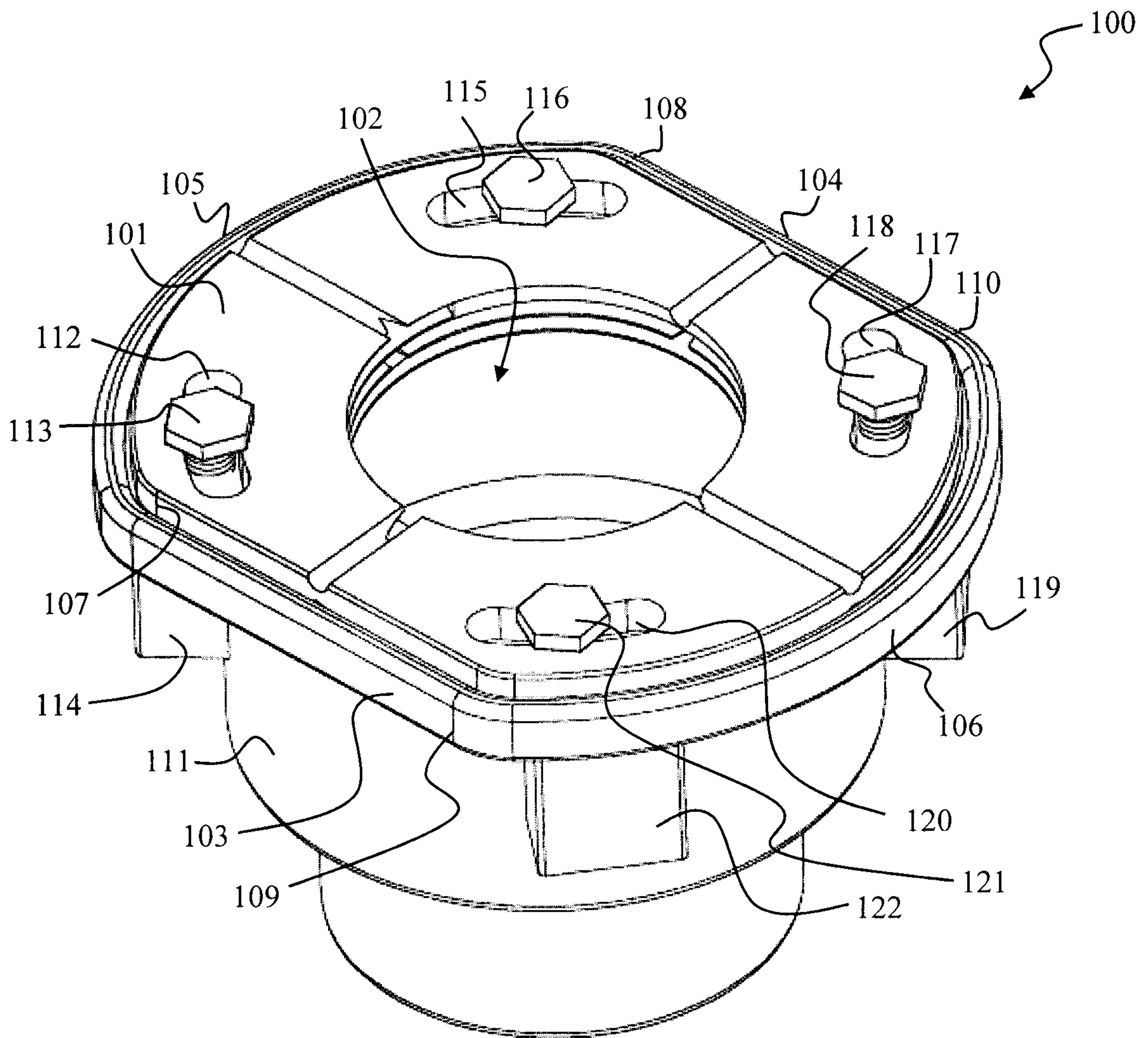

FIG. 1

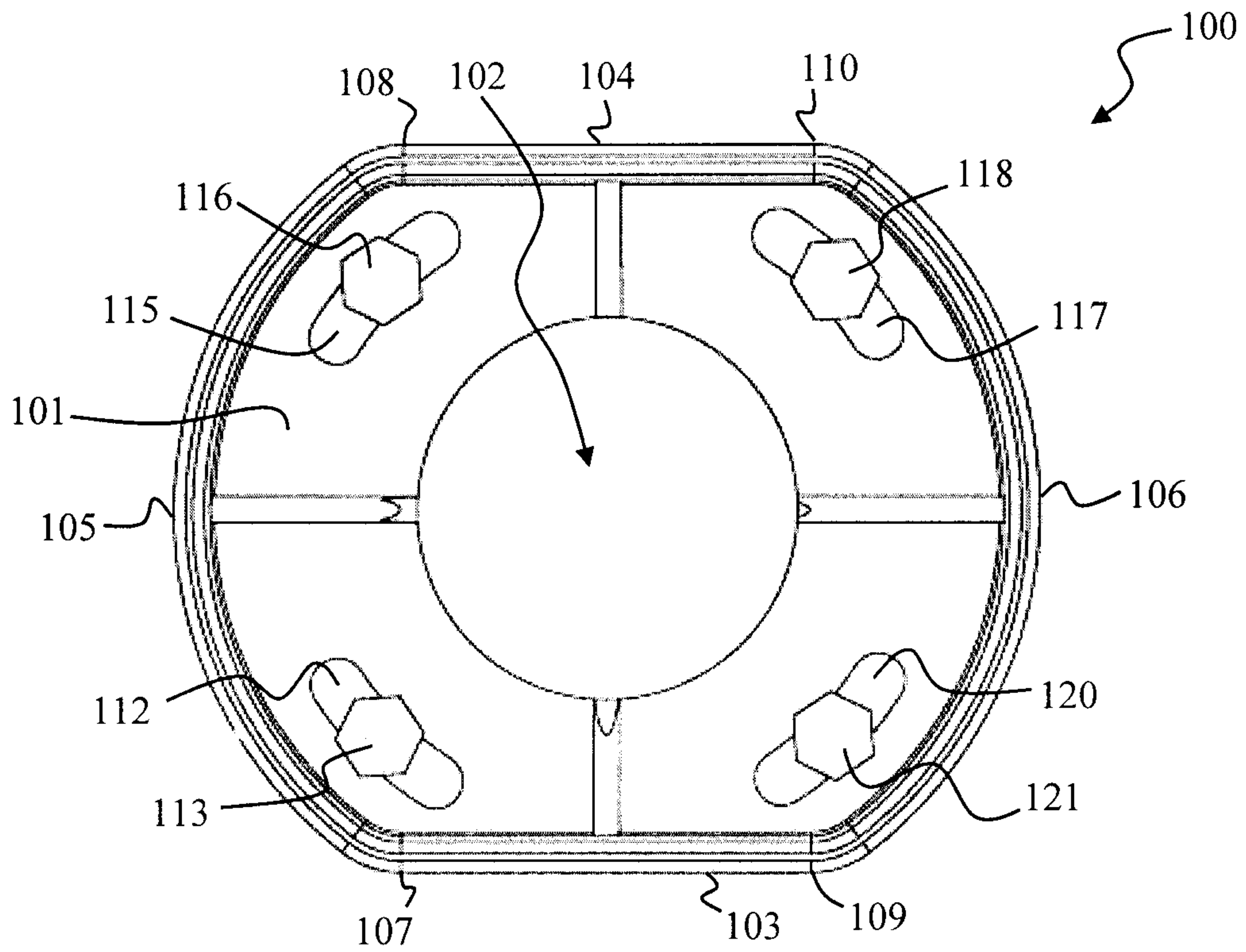

FIG. 2

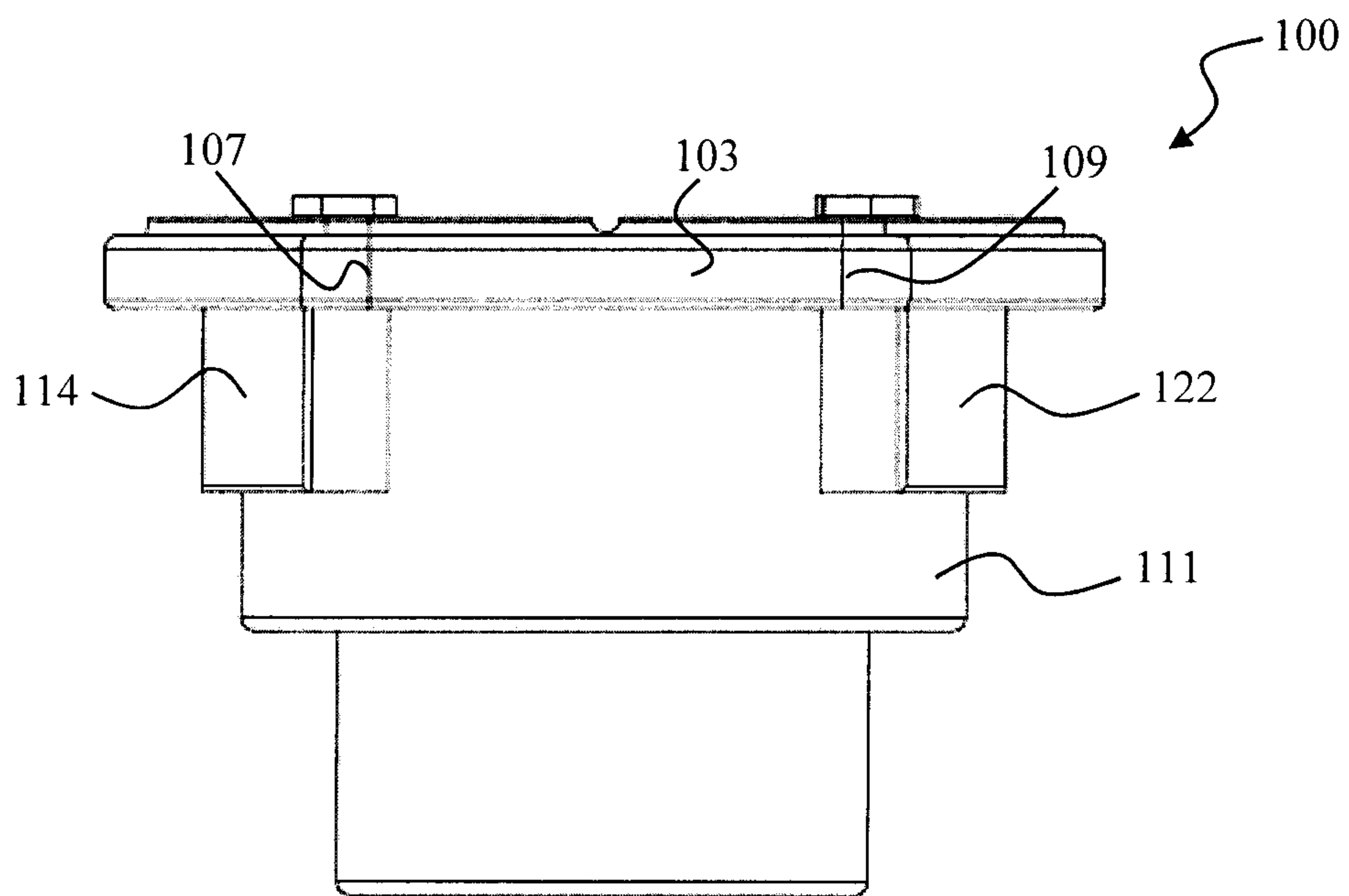

FIG. 3

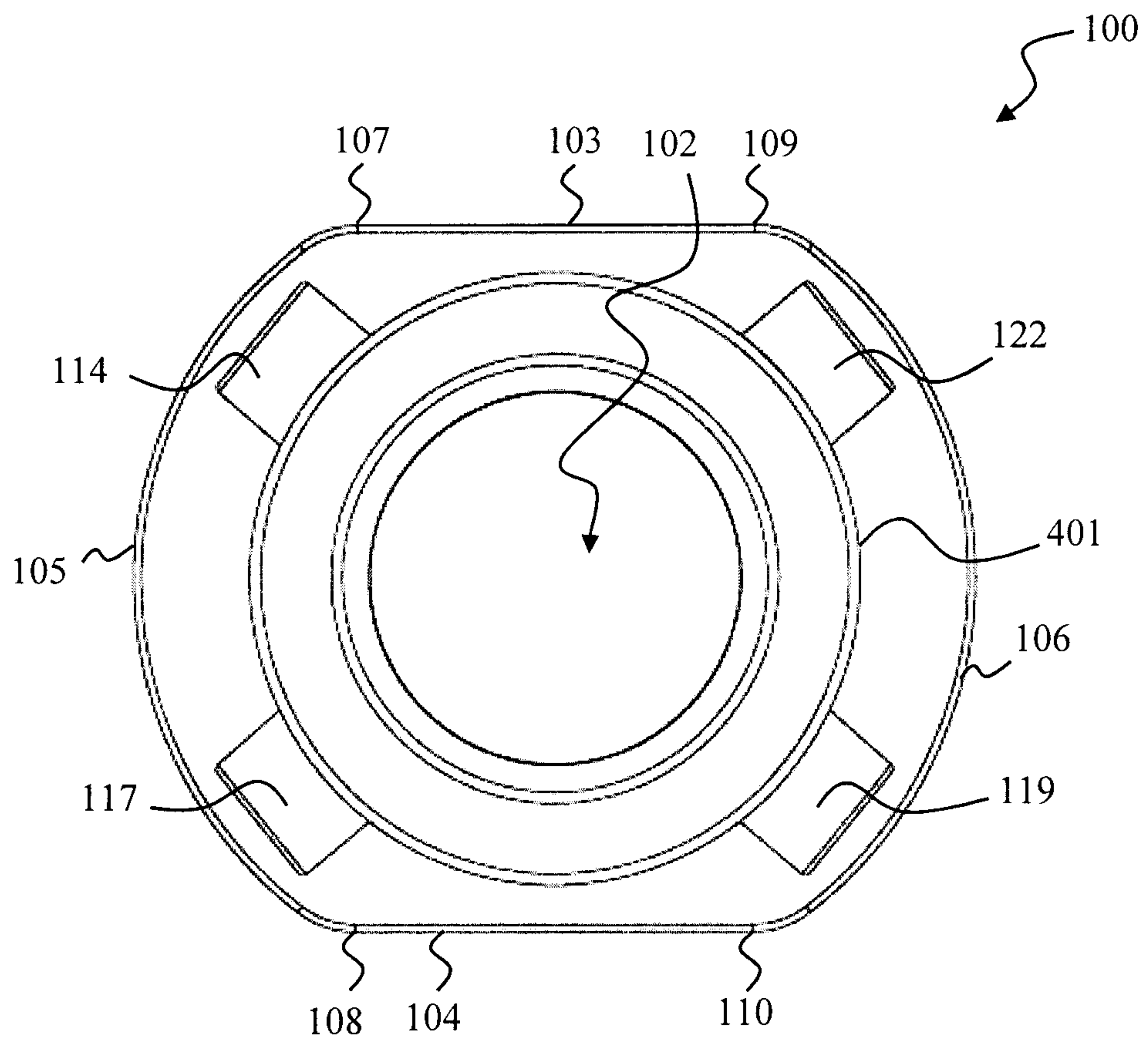

FIG. 4

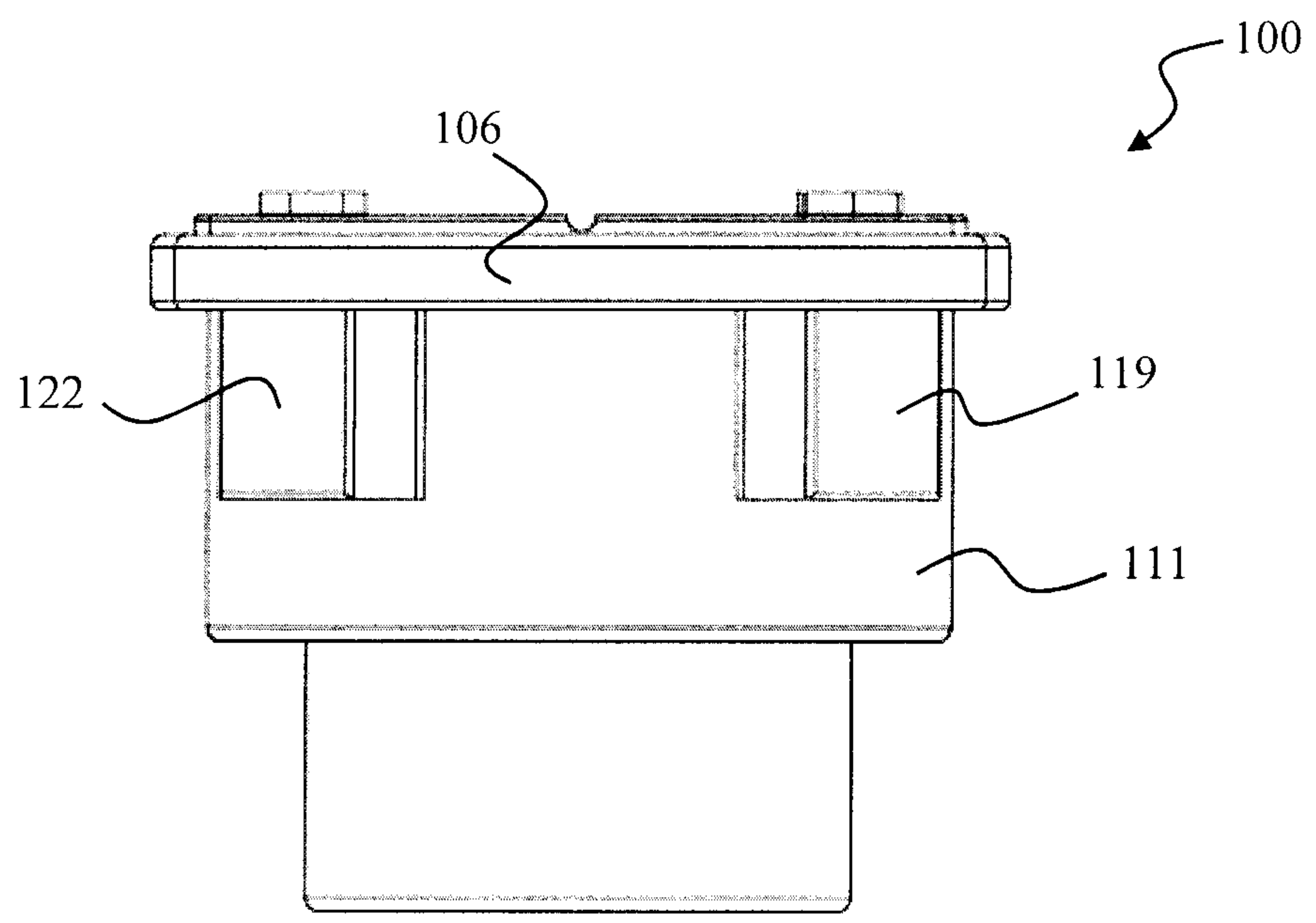

FIG. 5

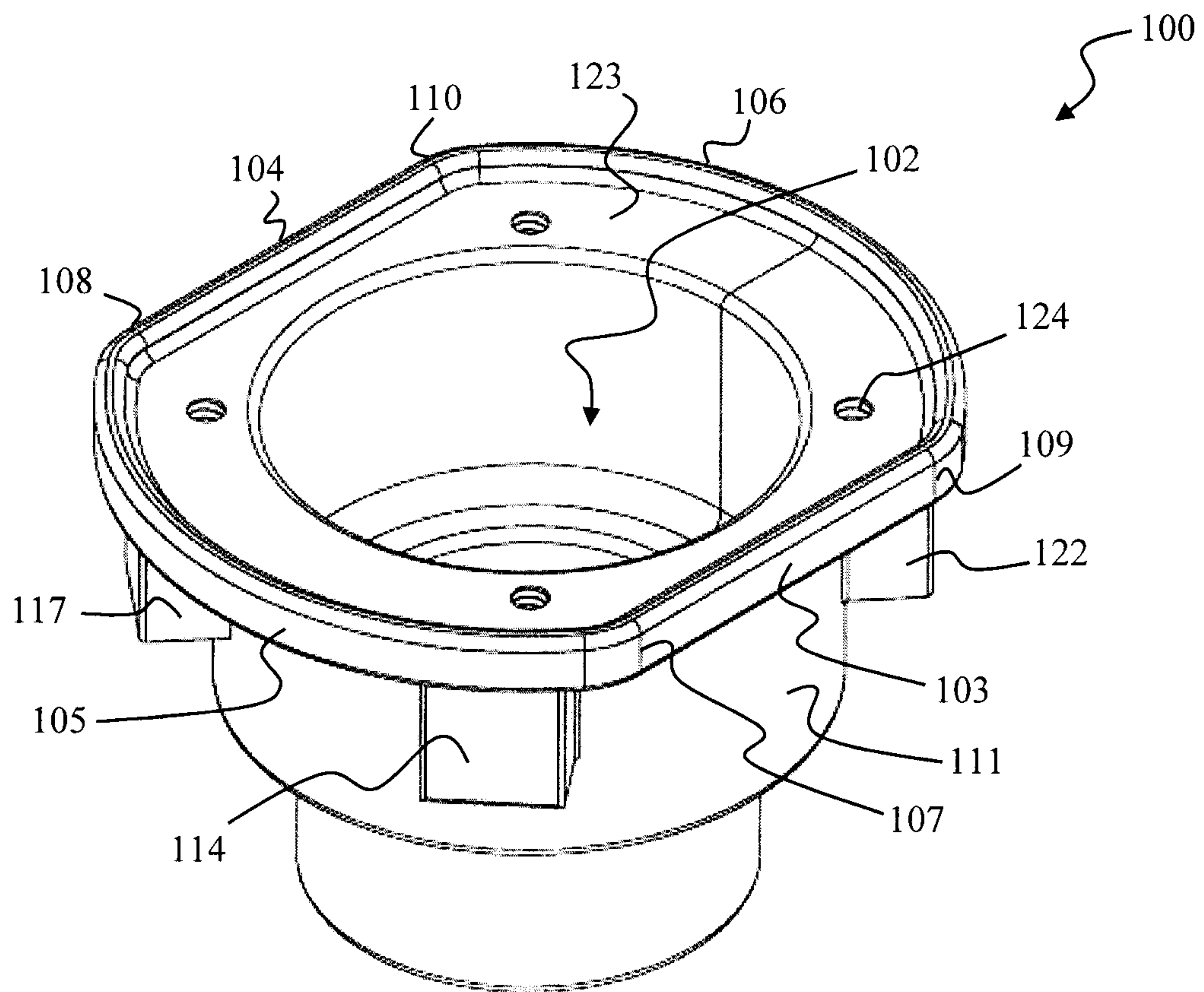

FIG. 6

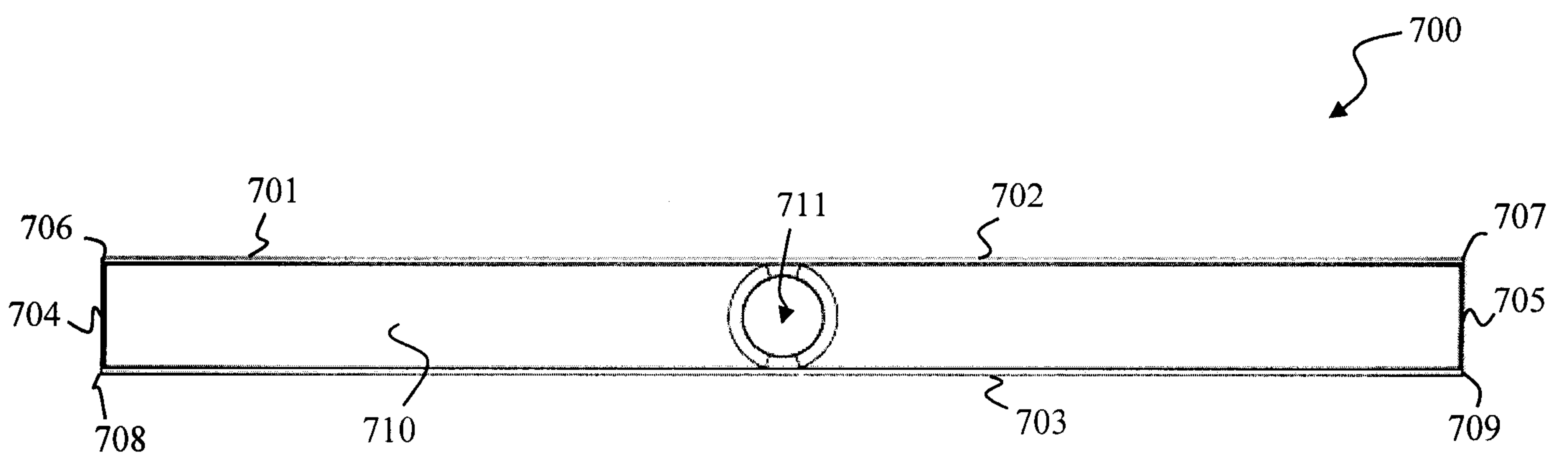

FIG. 7

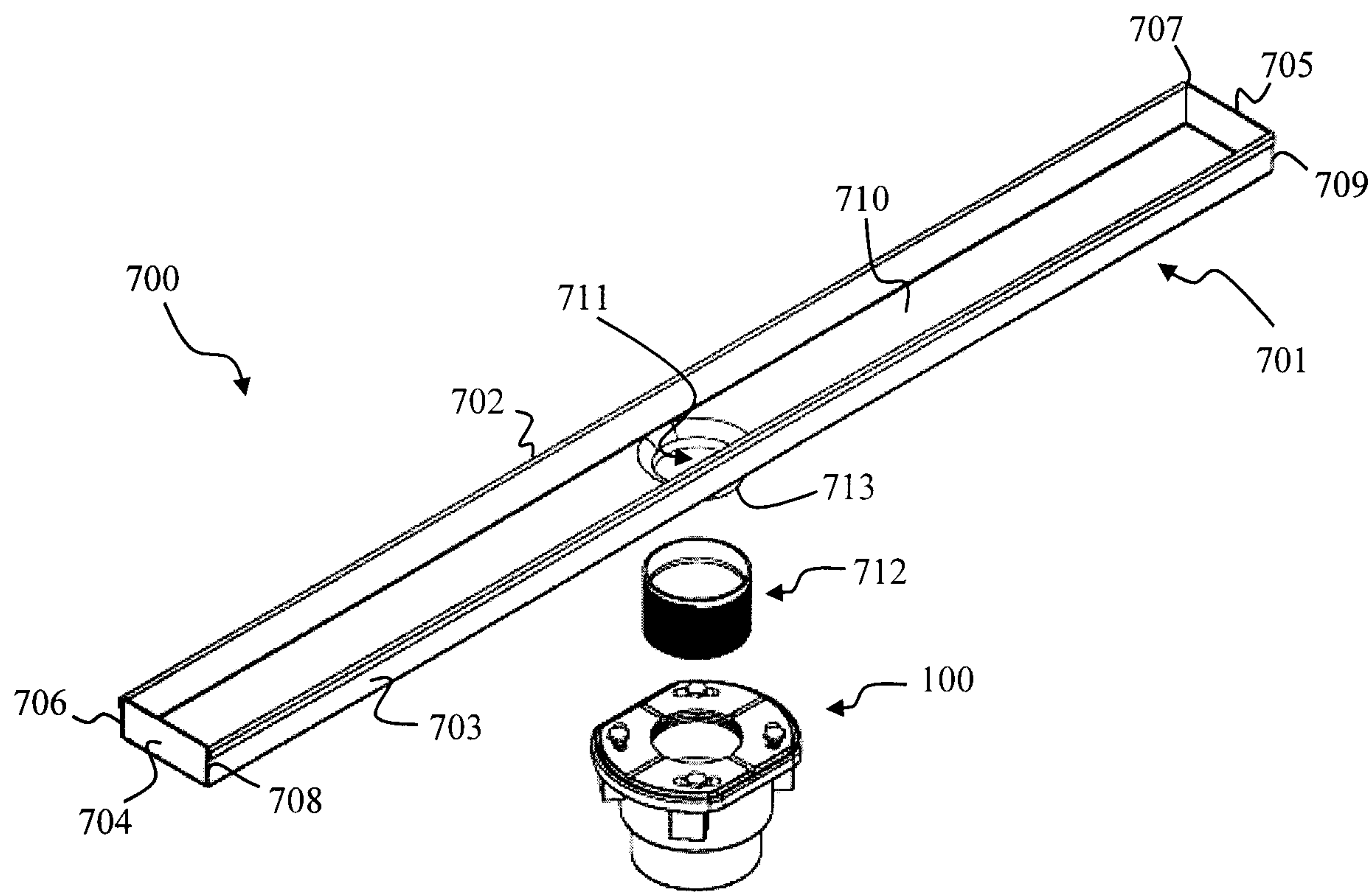

FIG. 8

