

(21) Application No 8127269
(22) Date of filing 9 Sep 1981
(30) Priority data
(31) 55/126549
(32) 11 Sep 1980
(33) Japan (JP)
(43) Application published
6 May 1982
(51) INT CL³
B65H 29/40
(52) Domestic classification
B8R 611 632 654 661 662
681 721 741 SS
(56) Documents cited
GB 1065488
(58) Field of search
B8R
(71) Applicants
Laurel Bank Machine
Company Limited,
No. 1-2, 1-Chome,
Toranomon,
Minato-ku,
Tokyo,
Japan.

(72) Inventors
Eiichi Kokubo,
Makoto Yamazaki,
Hiroshi Emori.
(74) Agents
Forrester, Kettle & Co.,
Forrester House,
52 Bounds Green Road,
London N11 2EY.

(54) Sheet stacker

(57) A sheet stacker, particularly for bank notes, includes a plurality of paddle wheels (3) each having a plurality of overlapping paddles (4). Sheets (5) are fed by a conveyer between the paddles as the paddle wheels rotate. A guide belt (22) is provided adjacent to the paddle wheels to restrain the free movement of the trailing ends (5b) of the sheets and to prevent the sheets from slipping out from the paddle wheels. The guide belt (22) moves at a speed substantially equal to the speed of the trailing free ends of the paddles so as to facilitate smooth travel of the sheets carried by the paddle wheels. A scraper plate (6) is disposed beneath the paddle wheels to remove the sheets from the paddle wheels, and a carrier plate (7) receives the sheets removed from the paddle wheels. The stacked sheets are subsequently transferred to discharge tray (10) or reject box (9).

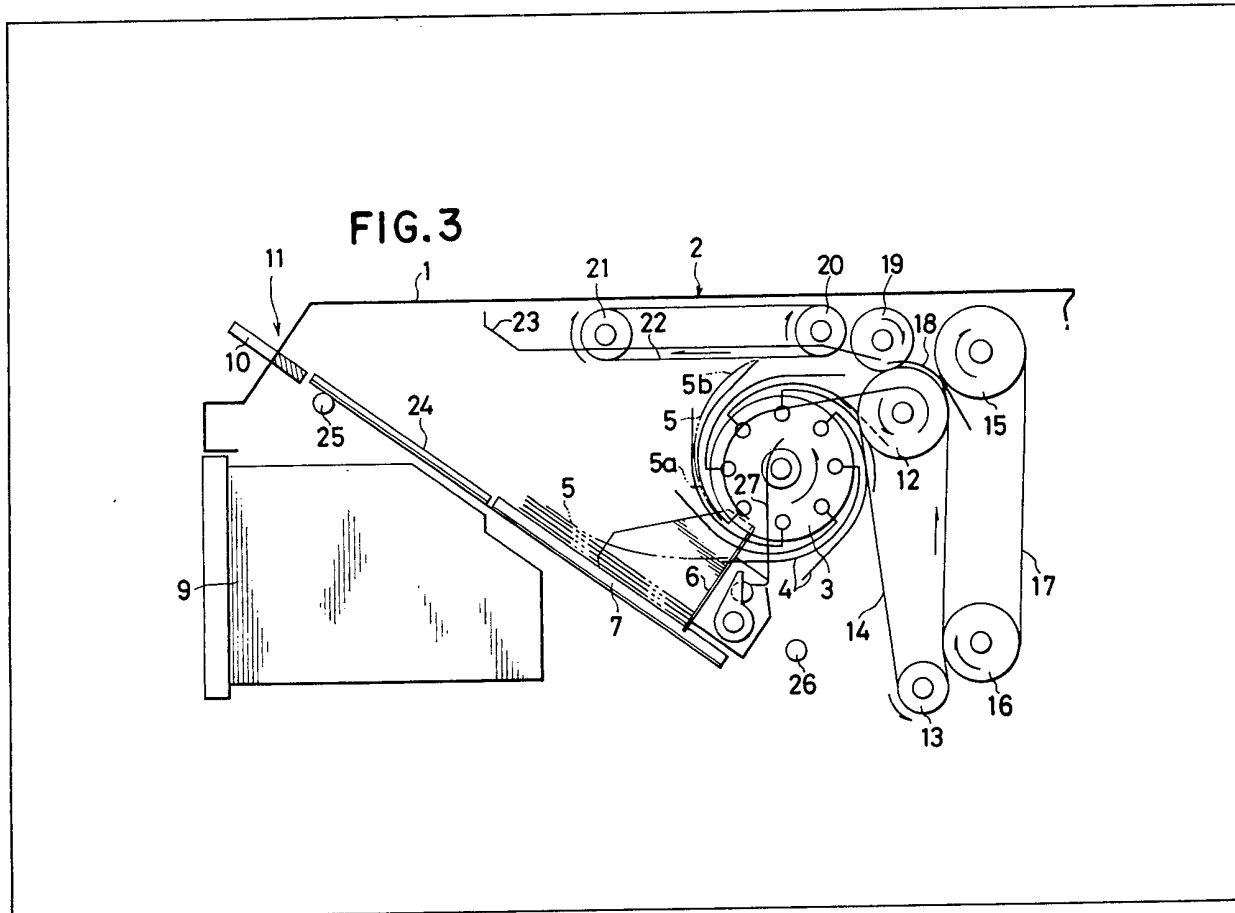

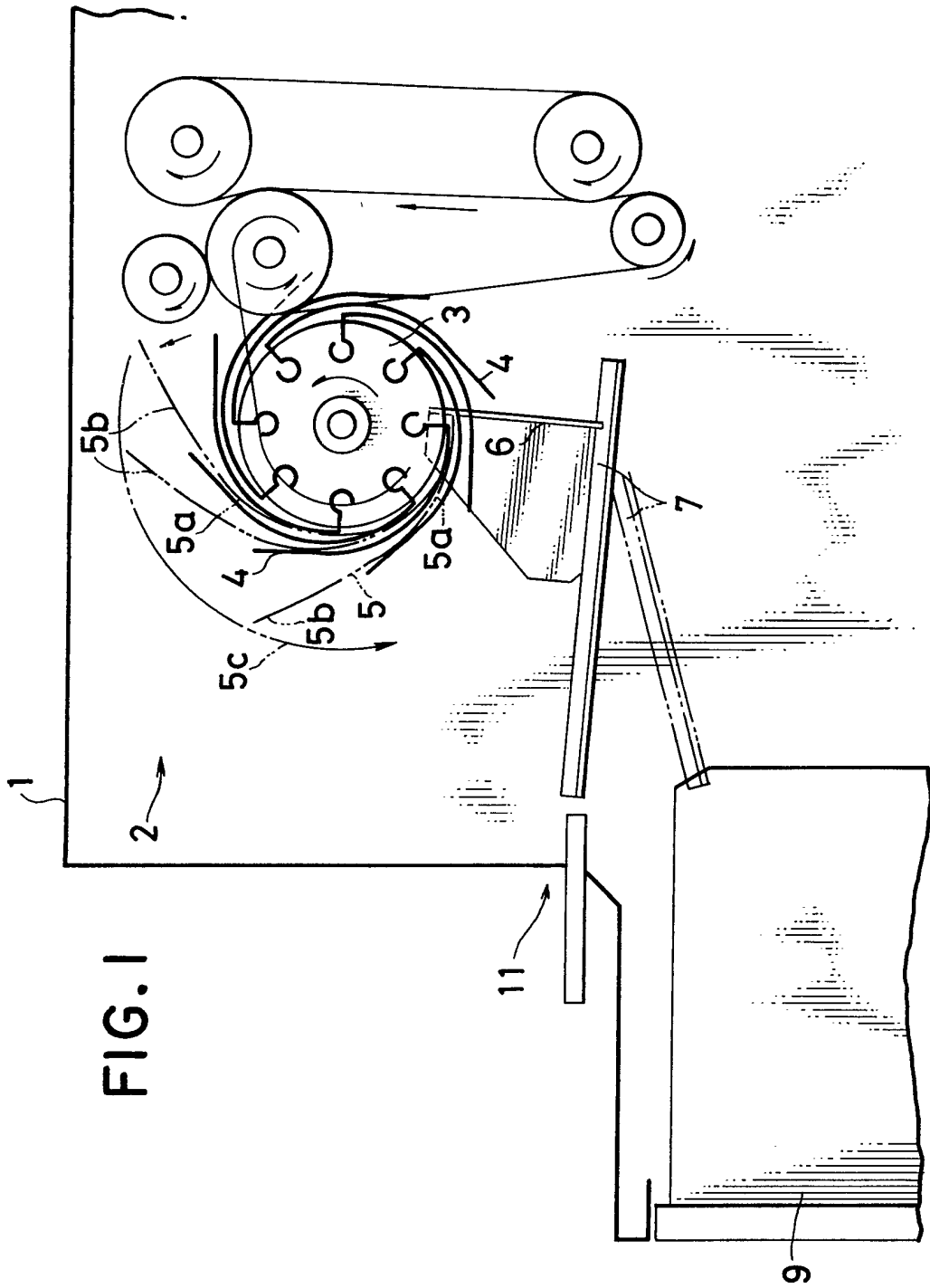

FIG. 2

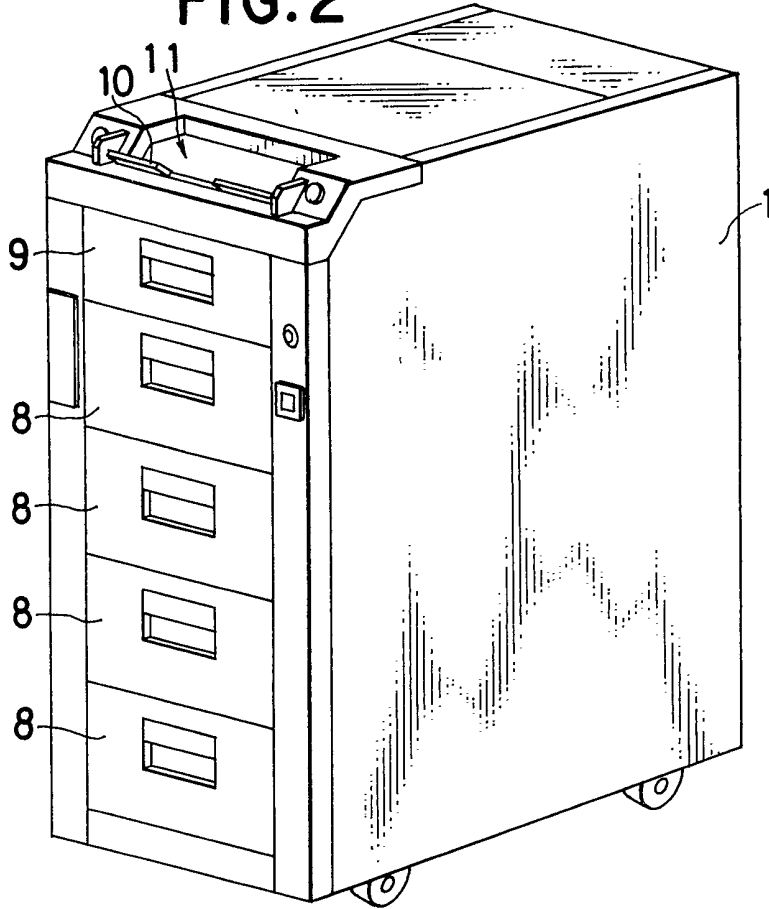
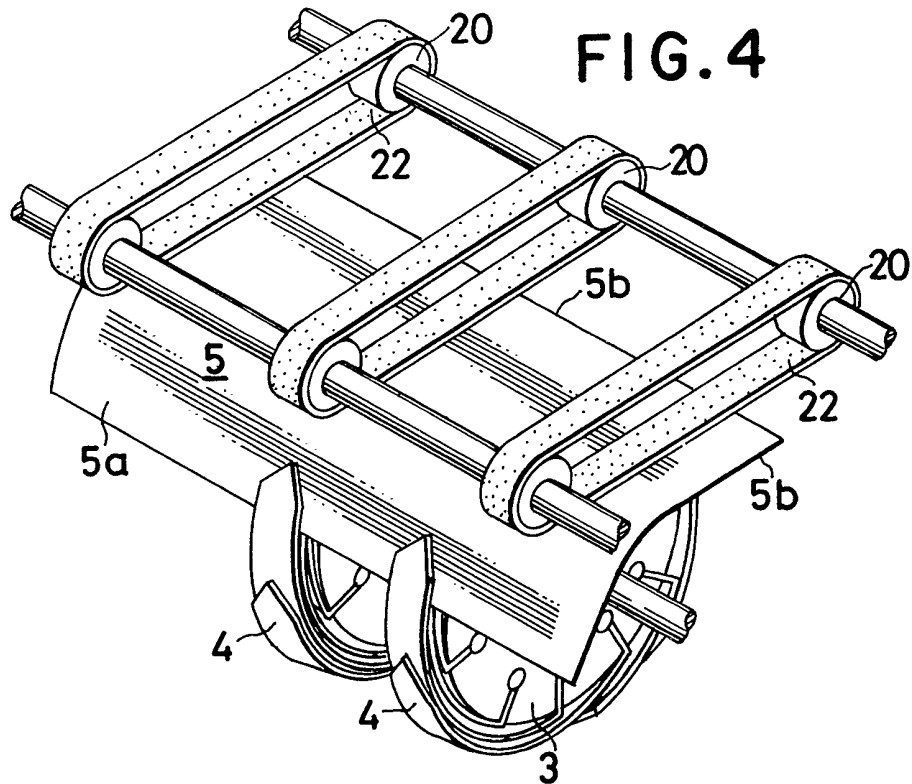
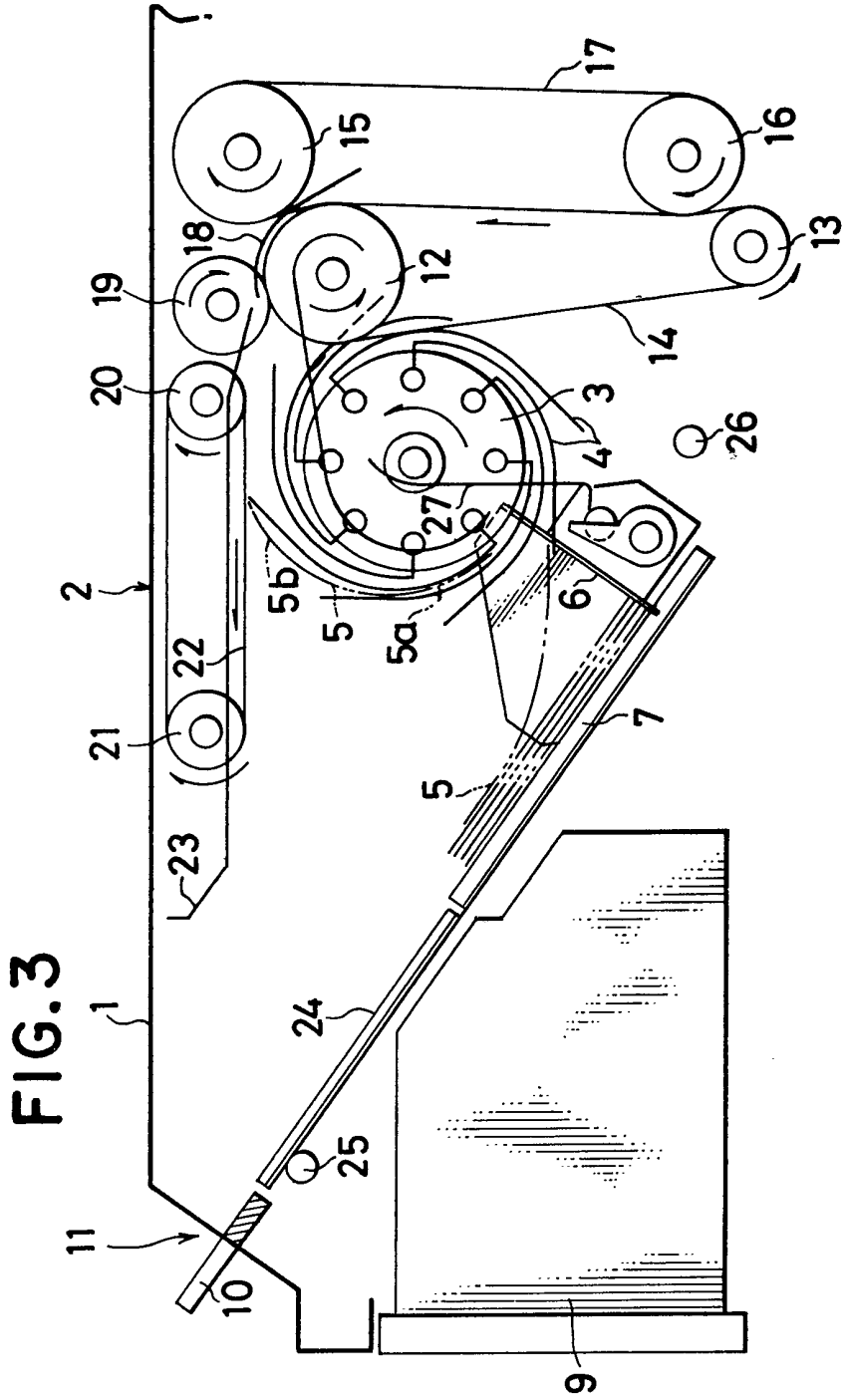

FIG. 4





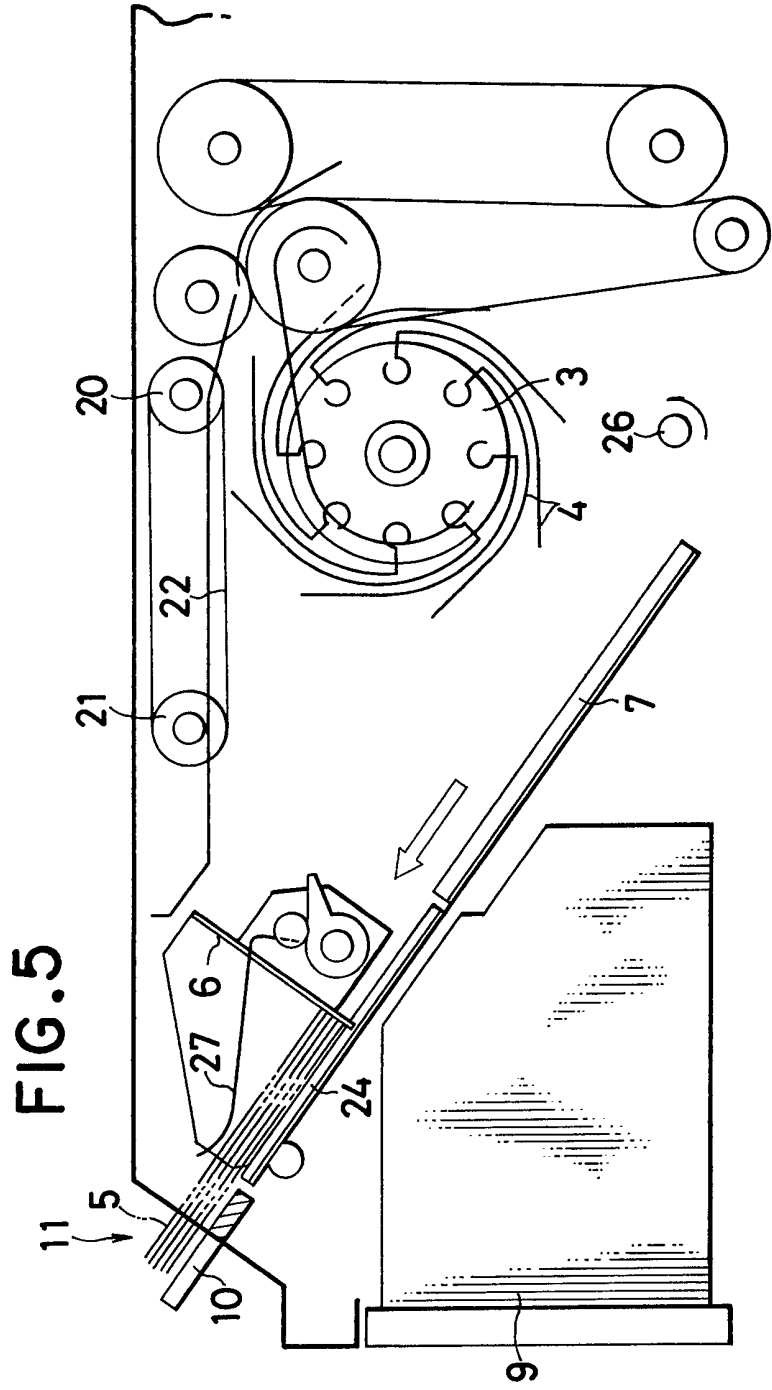
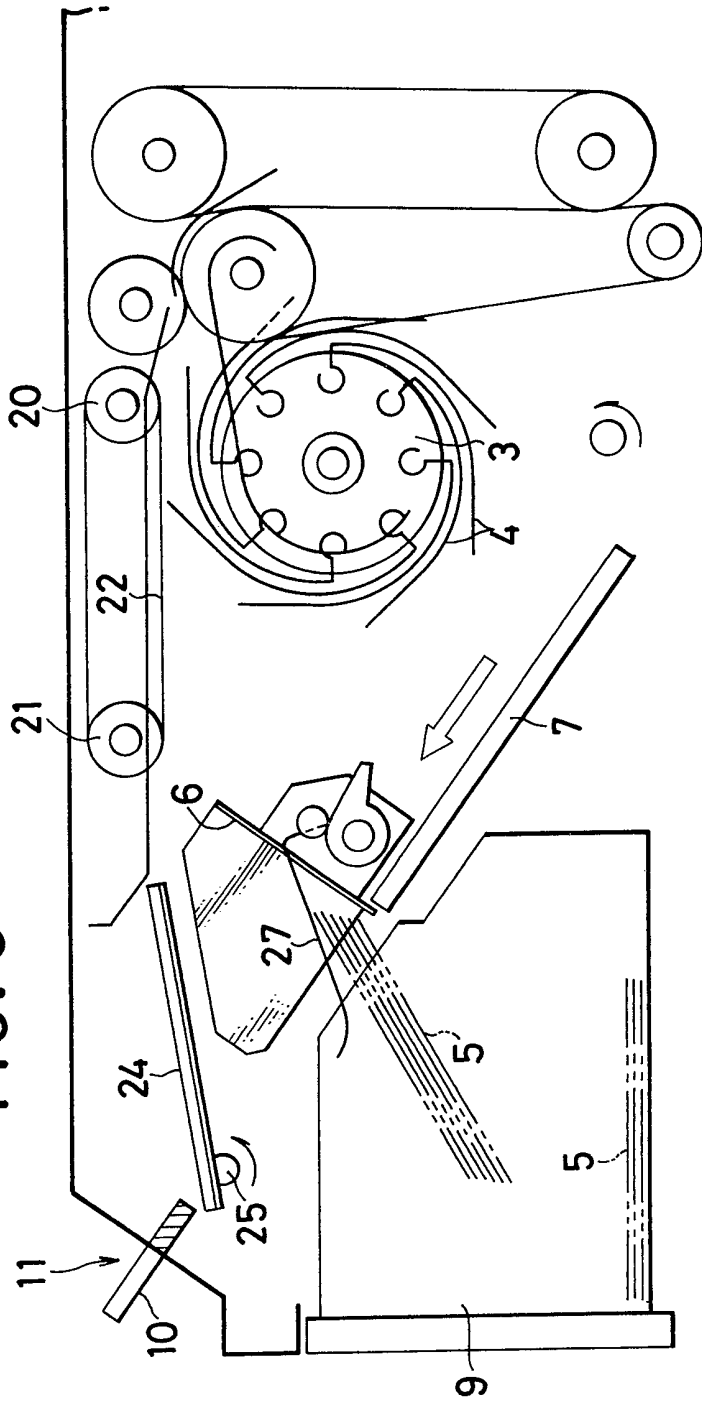

FIG. 6



SPECIFICATION

Sheet accumulating apparatus

5 This invention relates to a sheet accumulating apparatus for accumulating sheets of a material, for example paper, in a stack at an accumulation station from which the accumulated sheets are to be dispensed together. The invention is particularly applicable to a bank note accumulating apparatus for a bank note dispenser.

10 In a bank note dispenser, bank notes are supplied from a plurality of bank note stackers containing different sorts of bank notes and passed to a bank note accumulating apparatus to be accumulated to form a stack of bank notes containing the required numbers of designated types of bank notes. The bank notes must be accumulated in good order.

15 *Figure 1* of the accompanying drawings shows a known bank note dispenser 1 provided with a bank note accumulating apparatus 2. The known bank note accumulating apparatus 2 shown in *Figure 1* is arranged in the upper portion of the bank note dispenser 1, and includes paddle wheels 3 each having a plurality of overlapping paddles 4. Bank notes 5 supplied by a feed device, not shown, are inserted between the paddles 4 of the paddle wheels 3. Each of the bank notes 5 is carried by the rotating paddle wheels 3 until its leading end 5a abuts a scraper plate 6. The bank notes are removed from the paddle wheels 3 by the scraper plate 6 and are accumulated on a carrier plate 7.

20 In the known accumulating apparatus 2 referred to above, only the leading end 5a of each bank note 5 is inserted between paddles 4 of the paddle wheels 3, and the trailing end 5b of the bank note is left free. Upon rotation of the paddle wheels 3, the free trailing end 5b of a bank note moves along a substantially circular path 5c. The area encompassed by the path 5c is considerably larger than the area encompassed by the circle drawn by the rotating free ends of the paddles 4. Some devices, such as sensors for detecting the bank notes, cannot be arranged within the compass of the circular path 5c since such devices would hinder the travel of the free ends 5b of the bank notes 5. Moreover, the circular path 5c described by the free end 5b of each bank note 5 varies thereby enlarging the area of vacant space necessary to accommodate the travelling free ends 5b of the bank notes 5. Provision of vacant space in the vicinity of the paddle wheels 3 inevitably increases the dimensions of the bank note accumulating apparatus 2, resulting in an increase in the dimensions of the bank note dispenser 1.

25 It is an object of the present invention to reduce the vacant space necessary for accommodating the trailing ends of the paper sheets to a minimum.

30 Accordingly, the invention provides an accumulating apparatus for accumulating in a stack sheets of material to be dispensed together, which apparatus comprises a plurality of rotatable paddle wheels each having a plurality of overlapping paddles for receiving the sheets therebetween, guide belt means movable at a speed substantially equal to the speed of the trailing free ends of the paddles and arranged

adjacent the peripheries of the paddle wheels to restrain the movement of the free ends of the sheets carried by the paddle wheels, a scraper plate disposed beneath the paddle wheels for removing the sheets from the paddle wheels, and a carrier plate for receiving the sheets removed from the paddle wheels.

35 In a preferred embodiment, the sheets of material are sheets of paper, such as bank notes where the sheets are bank notes, the accumulating apparatus may form part of a bank note dispenser.

40 In order that the invention may be more readily understood, an embodiment thereof will now be described, by way of example, with reference to the accompanying drawings, in which:

45 *Figure 1* illustrates diagrammatically a known bank note accumulating apparatus;

50 *Figure 2* is a perspective view showing the exterior of a bank note dispenser incorporating a paper sheet accumulating apparatus embodying the invention;

55 *Figure 3* is a diagrammatic sectional view of part of a paper sheet accumulating apparatus embodying the invention;

60 *Figure 4* is a perspective view of a portion of the accumulating apparatus illustrated in *Figure 3*, showing a bank note grasped in between the peripheries of the paddle wheels and the guide belt assembly; and

65 *Figures 5* and *6* are schematic representations of a bank note dispenser incorporating the paper sheet accumulating apparatus, showing the operation of the bank note dispenser.

70 Referring now to *Figures 2* to *6* of the drawings, *Figure 2* shows a bank note dispenser 1 having a plurality of stacker or container boxes 8 for containing different sorts of bank notes. Each of the stacker boxes 8 is in the form of a drawer which is slidably received in a housing of the dispenser 1. A reject box 9 is housed above the stacker boxes 8. A cash tray 10 is disposed at a discharge port 11 formed at the top portion of the housing.

75 *Figure 3* is a diagrammatic sectional view of a bank note accumulating apparatus 2 embodying the invention. The accumulating apparatus 2 includes a plurality of paddle wheels 3 which are associated with a conveyor assembly for conveying bank notes 5 supplied from the bank note stacker boxes 8 by a feed device (not shown). As shown, the conveyor assembly includes a conveyor belt 14 stretched over pulley rollers 12 and 13 and another conveyor belt 17 stretched over pulley rollers 15 and 16. The bank notes are conveyed between the upwardly-moving runs of the belts 14 and 17, and then guided by a guide plate 18 for insertion between the paddle 4 of the paddle wheels 3. A rotating roller 19 engages with the belt 14 to facilitate smooth delivery of the bank notes 5.

80 A guide belt assembly is arranged above the paddle wheels 3 and comprises pulley blocks 20 secured to a rotating shaft, pulley blocks 21 secured to another rotating shaft, and guide belts 22 each stretched over an opposing pair of pulleys 20 and 21. The lower run of each guide belt 22 is contiguous with the trailing ends of the paddles 4 and moves at a speed substantially equal to the speed of the

trailing ends of the paddles 4. A guide plate 23 extends parallel to the lower runs of the guide belts 22.

A scraper plate 6 is arranged beneath the paddle wheels 3 and is provided with lugs which protrude between adjacent paddle wheels 3. The leading ends of the bank notes 5 abut the lugs of the scraper plate 6 to be scraped away from the underside of the paddles 4 and accumulated one by one on a carrier plate 7.

A gate plate 24 extends beyond the carrier plate 7 in normal operating condition and has a top face substantially flush with the top face of the carrier plate 7. However, the gate plate 24 may be swung upwardly as shown in Figure 6, about a shaft 25 to allow the bank notes 5 accumulated on the carrier plate to pass to the reject box 9 positioned beneath the gate plate 24. A drive motor (not shown) having a shaft 26 is provided to move the scraper plate 6 along the ramp formed by the top faces of the carrier plate 7 and the gate plate 24. A spring-biased arm 27 is provided to hold the bundle or stack of accumulated bank notes.

In operation of the bank note accumulating apparatus 2, bank notes 5 supplied one by one from the bank note stacker boxes 8 are conveyed and guided by the belts 14, 17, the guide plate 18 and the roller 19 for insertion between the paddles 4. As the paddle wheels 3 rotate, for example, in the counter-clockwise direction as viewed in Figure 3, the bank notes are carried to a position at which the leading ends of the bank notes abut against the scraper plate 6. As the bank notes 5 are carried by the rotating paddle wheels 3, the trailing ends 5b thereof contact the lower run of the guide belts 22 which move at a speed substantially equal to the speed of the free ends of the paddles 4, thereby preventing random expansion or repelling movement of the free ends of the bank notes and ensuring reliable carrying operation. The bank notes 5 are thus prevented from slipping out of the paddle wheels.

After the required number of designated types of bank notes have been accumulated on the carrier plate 7 and it has been ascertained that no error is involved in the operations, the accumulated bank notes are moved upwardly by moving the scraper plate 6 along the ramp formed by the top faces of the carrier plate 7 and the gate plate 24 onto the cash tray 10, as shown in Figure 5. However, if any error or malfunction is involved in the operations and detected by various sensors associated with the dispenser 1, e.g. when double supply or erroneous mixing of undesired bank notes is found, the gate plate 24 is swung upwardly about the shaft 25, as shown in Figure 6, to allow the accumulated bank notes to fall into the reject box 9.

Thus, a paper sheet accumulating apparatus embodying the invention restrains the free movement of the trailing or free ends of the sheets facilitating smooth travel of the sheets carried by the paddle wheels and preventing the sheets slipping out of the paddle wheels.

Of course, sheet accumulating apparatus embodying the invention may be used to handle sheets of paper or any similar material.

CLAIMS

1. An accumulating apparatus for accumulating in a stack sheets of material to be dispensed together, which apparatus comprises a plurality of rotatable paddle wheels each having a plurality of overlapping paddles for receiving the sheets therebetween, guide belt means movable at a speed substantially equal to the speed of the trailing free ends of the paddles and arranged adjacent the peripheries of the paddle wheels to restrain the movement of the free ends of the sheets carried by the paddle wheels, a scraper plate disposed beneath the paddle wheels for removing the sheets from the paddle wheels, and a carrier plate for receiving the sheets removed from the paddle wheels.
2. Apparatus according to claim 1, wherein the free ends of the sheets carried by the paddle wheels contact the guide belt means.
3. Apparatus according to claim 1 or 2, wherein the sheets of material are sheets of paper.
4. Apparatus according to claim 3, wherein the paper sheets are bank notes.
5. Apparatus according to claim 4, wherein the apparatus is incorporated in a bank note dispenser.
6. A sheet accumulating apparatus substantially as hereinbefore described with reference to and as illustrated in Figures 2 to 6 of the accompanying drawings.
7. Any novel feature or combination of features described herein.

Printed for Her Majesty's Stationery Office, by Croydon Printing Company Limited, Croydon, Surrey, 1982.
Published by The Patent Office, 25 Southampton Buildings, London, WC2A 1AY, from which copies may be obtained.