

(21) Application No 9108587.8

(22) Date of filing 22.04.1991

(30) Priority data

(31) 02109641
02109300

(32) 24.04.1990
25.04.1990

(33) JP

(51) INT CL⁵
A61F 13/42

(52) UK CL (Edition K)
A3V V1B3B

(56) Documents cited
EP 0157649 A2 US 4834733 A US 4743238 A
US 4681576 A

(58) Field of search
UK CL (Edition K) A3V
INT CL⁵ A61F 13/00 13/42

(71) Applicant
Uni-Charm Corporation
(Incorporated in Japan)

182 Shimobun, Kinsei-cho, Kawano-shi, Ehime-ken,
Japan

(72) Inventors
Takamitsu Igaue
Tohru Sasaki
Hideaki Kitaoka

(74) Agent and/or Address for Service
Baron & Warren
18 South End, Kensington, London, W8 5BU,
United Kingdom

(54) Disposable training pants

(57) Baby disposable training pants comprise a liquid-permeable inner sheet 4, a liquid-impermeable outer sheet 5 and, if necessary, a liquid absorbent core 6 sandwiched therebetween, wherein at least a part of the inner sheet is formed from hydrophilic material to define a wetness sensing zone 12 so that, when a baby wearing the training pants excretes, the inner surface of the training pants is wetted and the baby senses this.

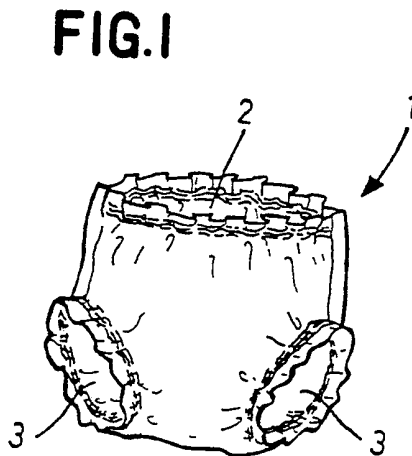

FIG. 2

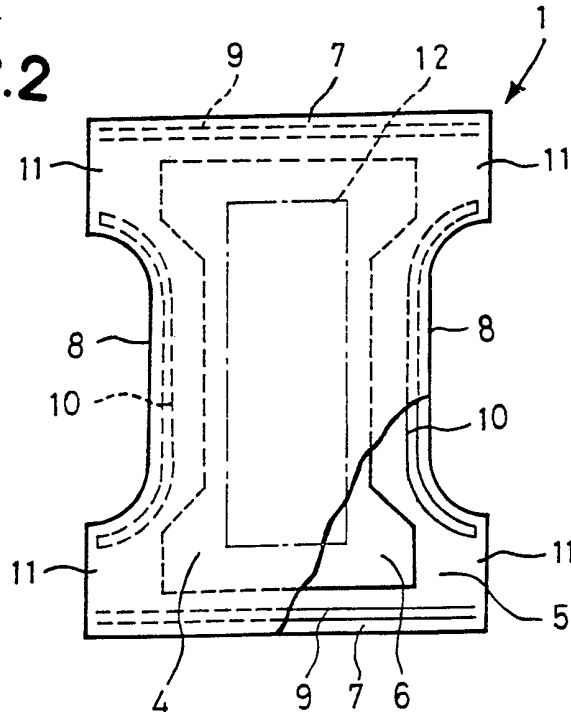

FIG.1

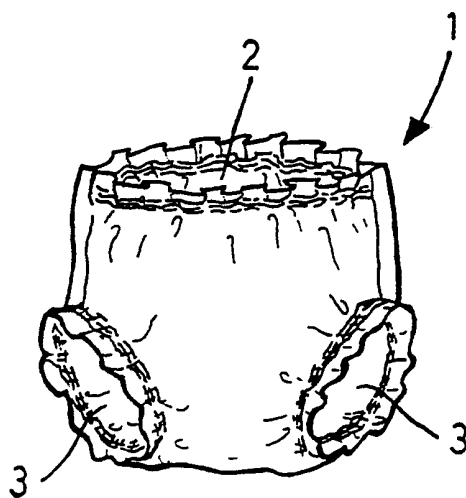

FIG.2

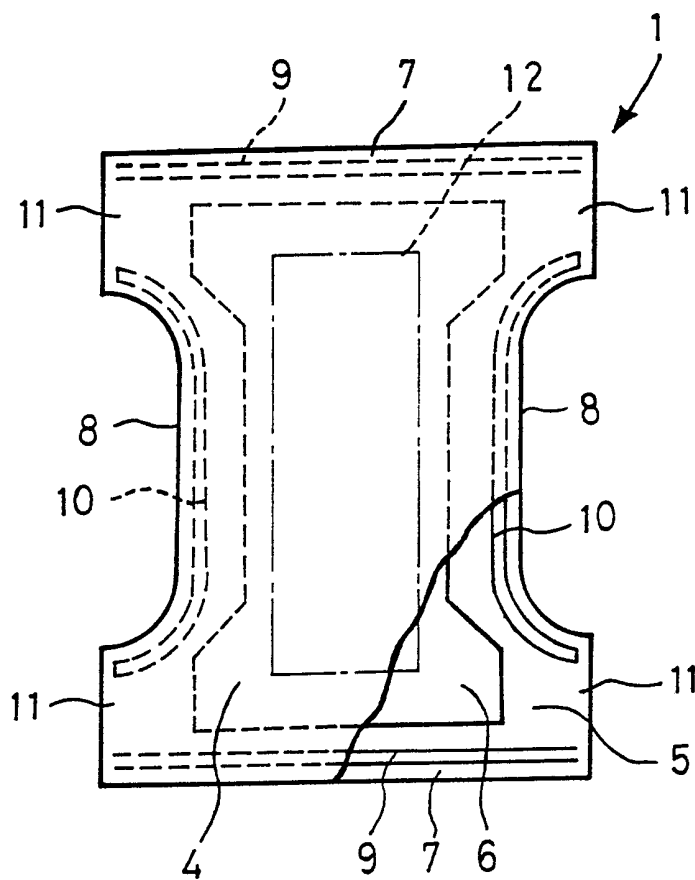

FIG.3

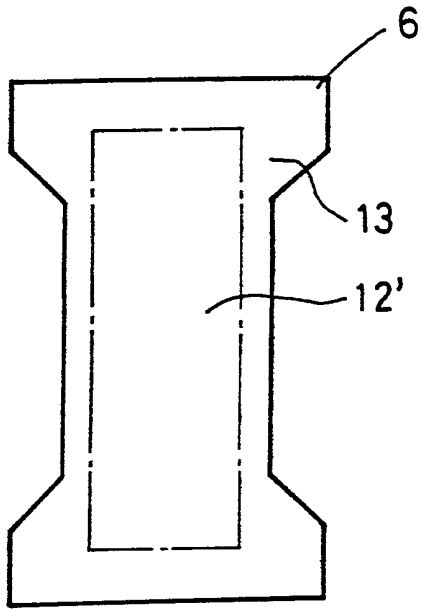

FIG.4

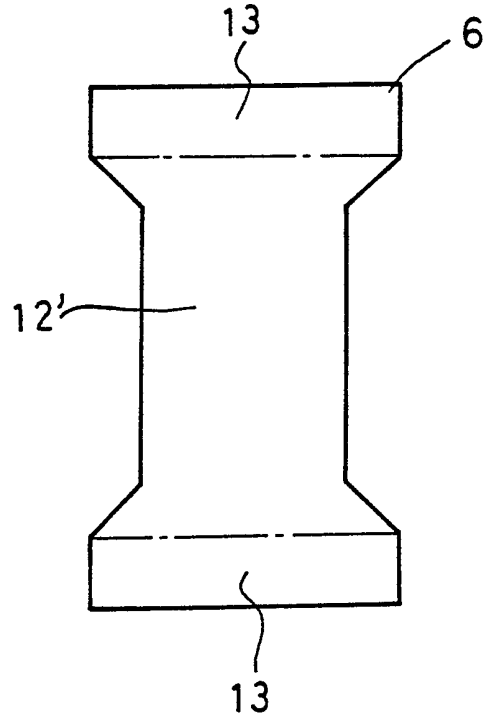
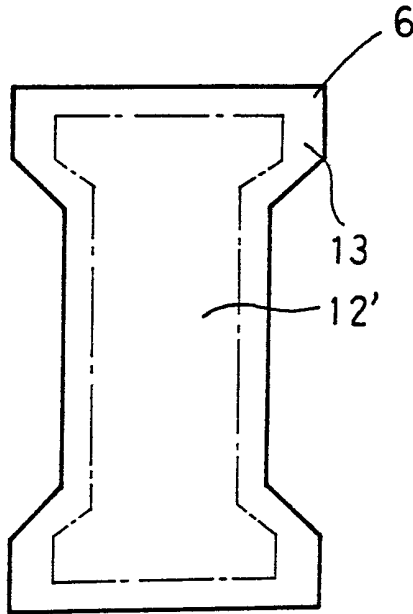

FIG.5



DISPOSABLE TRAINING PANTS

The present invention relates to disposable training pants and more particularly to so-called training pants utilized to make babies smoothly abandon a habit of relying on a diaper and to make them accustomed to a life not dependent on diapers as soon as possible.

The conventional training pants have generally been made of cloth and washable for repeated use.

Such washing has usually been annoying and, in addition, there has been a serious problem that, when a baby wearing the pants excretes, a quantity of liquid excretions often leaks out of the pants and stains the indoor floor surface.

Accordingly, it is an object of the present invention to provide improved disposable diapers adapted not only to achieve the proper function as the training pants such that, when a baby wearing the pants excretes, the pants wetted by liquid excretions should give the baby an unpleasant feeling, but also to prevent any quantity of such liquid excretions from leaking out of the pants.

The object set forth above is achieved, according to

the present invention, by disposable training pants having an elastically stretchable waist-opening and a pair of elastically stretchable leg-openings and basically comprising an inner sheet, an outer sheet and, if necessary, an absorbent core sandwiched between these inner and outer sheets, wherein said inner sheet and/or said absorbent core are provided with wetness sensing zones having a hydrophilic property.

Preferably, said wetness sensing zones are made hydrophilic by treating said wetness sensing zones with a suitable hydrophilizing agent or forming surfaces of these zones from suitable hydrophilic material.

When a baby wearing the pants of the invention excretes, the wetness sensing zone provided on the inner sheet is thereby wetted and brought in direct contact with the baby's skin. In consequence, this wetness sensing zone gives the baby an unpleasant feeling and the baby senses that he or she has excreted. Thus, use of the pants effectively makes the baby acquire a habit of telling others when he or she has excreted.

In addition to such proper function of the training pants, another aspect of the present invention provides an important advantage such that the indoor floor surface is protected against being stained by possible leakage of liquid excretions, because the liquid-impermeable outer

sheet effectively prevents the liquid excretions from leaking out of the pants.

With the pants constructed according to the invention, the liquid-impermeable outer sheet blocks the liquid excretions and correspondingly improves a wetting effect for the wetness sensing zones. This improves, in turn, the proper function as the training pants. Such feature can not be found in the conventional training pants made of cloth.

The invention will be described by way of example with reference to the accompanying drawings, wherein:-

Fig. 1 is an isometric view showing an embodiment of training pants constructed according to the present invention;

Fig. 2 is a plan view of the pants illustrated by Fig. 1 as unfolded, showing an inner sheet provided with a wetness sensing zone; and

Figs. 3 through 5 are plan views of an absorbent core provided with the wetness sensing zone of various configurations, respectively.

Referring to Figs. 1 and 2, pants 1 include an elastically stretchable waist-opening 2 and a pair of

elastically stretchable leg-openings 3. The pants 1 basically comprise a liquid-permeable inner sheet 4, a liquid-impermeable outer sheet 5 and a liquid absorbent core 6 in the form of sheet or mat.

Between the inner and outer sheets 4, 5, elastically stretchable members 9, 10 are secured in their stretched condition by means of adhesive along portions 7, 8 defining the waist-opening 2 and the leg-openings 3, respectively. Along a middle line of the pants 1 laterally extending as viewed in the unfolded condition shown by Fig. 2, the pants 1 may be longitudinally folded in two with the inner sheet 4 being inside and then opposite side zones 11 except the leg-openings 3 may be bonded together to obtain the pants as isometrically shown by Fig. 1.

The inner sheet 4 is made of suitable thermoplastic crimped fibres formed by the well known fluid jet fibers intertwining process into non-woven fabric being elastically stretchable both in length and width. A given zone of the inner sheet 4 may be treated by well known hydrophiling agent (such as surfactant) to define a wetness sensing zone 12 having a high wettability by liquid excretions. Alternatively, non-woven fabric made of suitable hydrophilic fibres such as rayon fibres or hydrophobic synthetic fibres which was hydrophiled (such as hydrophiled polyester fibres) or a combination thereof, or

hydrophiled paper (Japanese paper) or the like may be cut into a given size and integrally bonded to the top of said given zone. It is also possible to utilize the entire inner sheet 4 as the wetness sensing zone 12 and, in this case, non-woven fabric made of said hydrophilic or hydrophiled fibres or, if desired, a combination of such fibres and hydrophobic fibres may be used.

The outer sheet 5 is made of non-woven fabric formed from the same material as that of the inner sheet 4, said non-woven fabric being liquid-permeable and elastically stretchable both in length and width, and film of synthetic resin or rubber being similarly stretchable both in length and width integrally bonded to said non-woven fabric. Alternatively, it is possible to use non-woven fabric which is elastically stretchable both in length and width and liquid-impermeable or liquid permeation-resistant.

The present invention relates to the training pants and, therefore, it is not essential to incorporate the product with the liquid absorbent core 6. When such core 6 is used as in the illustrated embodiment, it is undesirable that this core 6 has a sufficiently high liquid absorptive power to absorb the liquid excretions wetting the inner sheet 4 so as to reduce the feeling of wetness which should be given to the baby wearing the pants.

However, when it is desired to use the core 6 so that

possible leakage of the liquid excretions can be further reliably avoided, the core 6 is preferably selected so that the liquid excretions once absorbed therein are readily exuded. Figs. 3 through 5 show several examples each including a wetness sensing zone 12' in the place of or in addition to said wetness sensing zone 12.

Referring to Figs. 3 through 5, the core 6 is provided at a given portion thereof with the wetness sensing zone 12' as indicated by a defining chain line. More specifically, a density in the wetness sensing zone 12' of the core may be lowered with respect to that in the remainder. In the case of the core 6 formed from fluffy pulp mixed with super-absorptive polymer powder, a quantity of super-absorptive polymer powder contained in the zone 12' should be smaller than that contained in the remainder, because by lowering said density or making smaller said quantity of super-absorptive polymer powder, the liquid excretion absorptive power is correspondingly decreased. In order to reduce the density in a limited area of the core 6, material quantity or thickness in the zone requiring no reduction of the density may be adjusted to be greater than that in the zone requiring reduction of the density and then the entire core 6 may be compressed to a substantially uniform thickness.

When a baby wearing the pants is sitting down, a load of approximately 35g/cm^2 is exerted on the pants.

Accordingly, it is preferred to design the wetness sensing zone 12' so that the liquid excretions once absorbed therein exude under a load less than $35\text{g}/\text{cm}^2$.

The wetness sensing zone 12' serves to rewet said wetness sensing zone 12 lying adjacent the former and thereby to improve the wetness sensing effect.

CLAIMS

(1) Disposable training pants having an elastically stretchable waist-opening and a pair of elastically stretchable leg-openings and basically comprising an inner sheet, an outer sheet and, if necessary, an absorbent core sandwiched between these inner and outer sheets, wherein said inner sheet is provided at least partially with a wetness sensing zone having a hydrophilic property.

(2) Pants as claimed in Claim (1), wherein the hydrophilic property of said wetness sensing zone is achieved by treating the portion of the inner sheet defining said zone with suitable hydrophilizing agent.

(3) Pants as claimed in Claim (1), wherein the hydrophilic property of said wetness sensing zone is achieved by forming at least a surface of said portion of the inner sheet defining said zone from suitable hydrophilic material.

(4) Disposable training pants having an elastically stretchable waist-opening and a pair of elastically stretchable leg-openings and basically comprising a liquid-permeable inner sheet, a liquid-impermeable outer sheet and a liquid absorbent core sandwiched therebetween, wherein said core is provided at least partially with a wetness sensing zone.

(5) Pants as claimed in Claim (4), wherein the portion

of the core defining said wetness sensing zone is adapted to have a higher liquid excretion exuding property with respect to the remainder under a certain load.

(6) Pants as claimed in Claim (5), wherein said load is less than 35g/cm^2 .

(7) Pants as claimed in claim 4, 5, 6 or 7, wherein the sheet is also hydrophiled over an area at least partially overlapping said wetness sensing zone of the core to define a wetness sensing zone.

(8) Pants as claimed in claim 4, 5, 6 or 7, wherein the hydrophilic property of said wetness sensing zone defined in the inner sheet is achieved by treating the portion of the inner sheet defining this zone with suitable hydrophiling agent.

(9) Pants as claimed in claim 4, 5, 6 or 7, wherein the hydrophilic property of said wetness sensing zone defined in the inner sheet is achieved by forming at least a surface of the sheet portion defining said zone from suitable hydrophilic material.

(10) Disposable training pants substantially as hereinbefore described with reference to the accompanying drawings.