

(21) Application No 9120729.0

(22) Date of filing 30.09.1991

(30) Priority data

(31) 9027192
9114048

(32) 14.12.1990
28.06.1991

(33) GB

(51) INT CL⁵
F16B 25/02

(52) UK CL (Edition K)
F2H HM H11A4 H11A6D1 H11A6G H21

(56) Documents cited
GB 2042120 A GB 1452955 A

(71) Applicant
Charles Bickford
10 Aldermans Hill, Hockley, Essex, SS5 4RW,
United Kingdom

(72) Inventor
Charles Bickford

(74) Agent and/or Address for Service
Hepworth Lawrence Bryer & Bizley
Gate House South, West Gate, Harlow, Essex,
CM20 1JN, United Kingdom

(58) Field of search
UK CL (Edition K) F2H HAA HM
INT CL⁵ F16B 25/00 25/02
On-line databases: WPI

(54) Masonry fixing screw

(57) A self-tapping masonry screw comprises a shank 2 formed with a rolled helical groove 5 next to one or two helical ridges 6 & 7, and with a land 9 relative to which the ridge(s) is raised and the groove 5 is depressed, the axial width of the land being at least 4mm and at least 50% of the land diameter, and the helix angle of the ridge is at least 10 degrees.

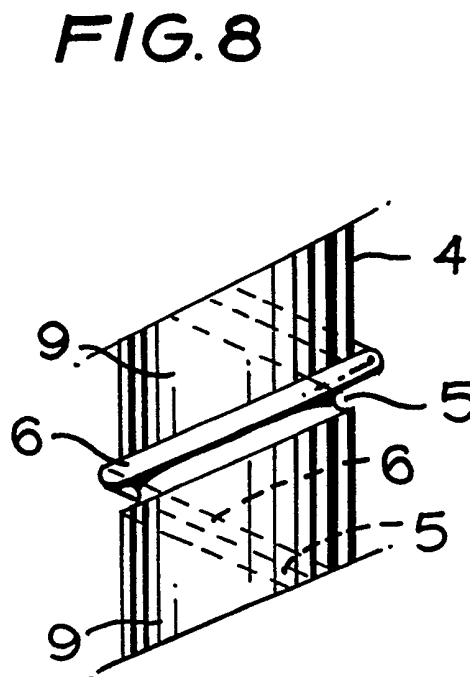
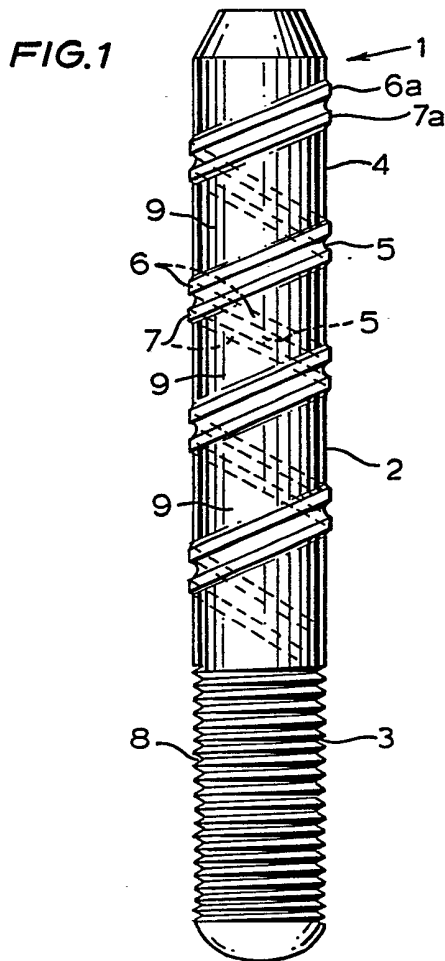

FIG. 1

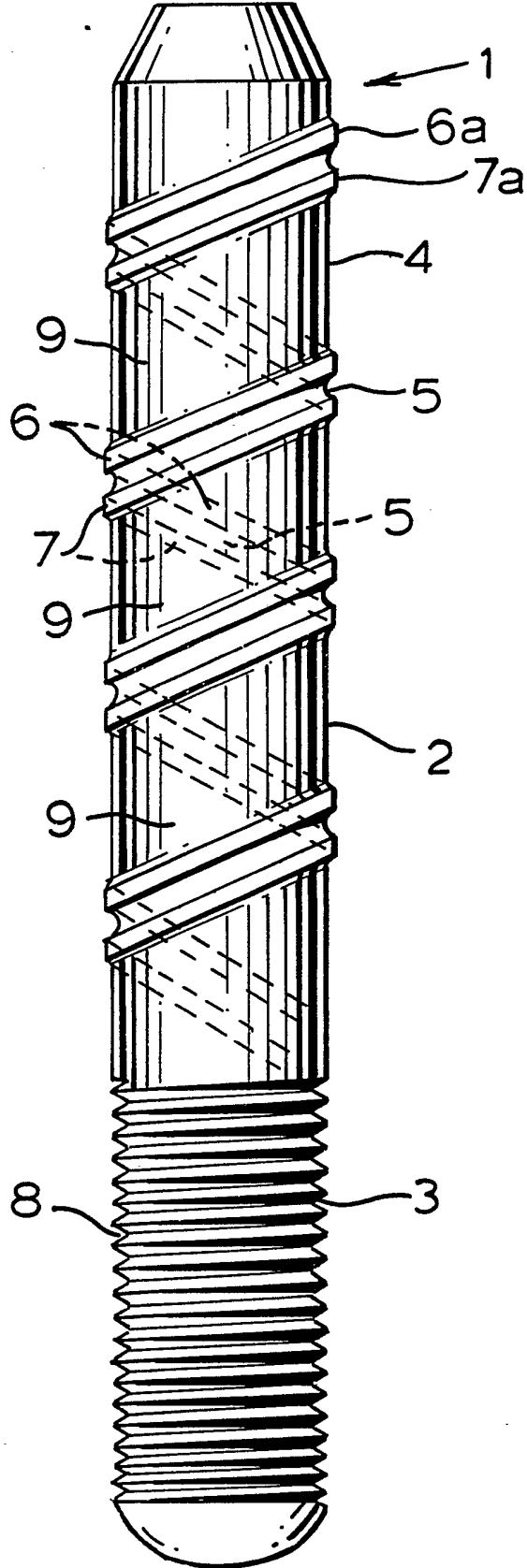

FIG. 2

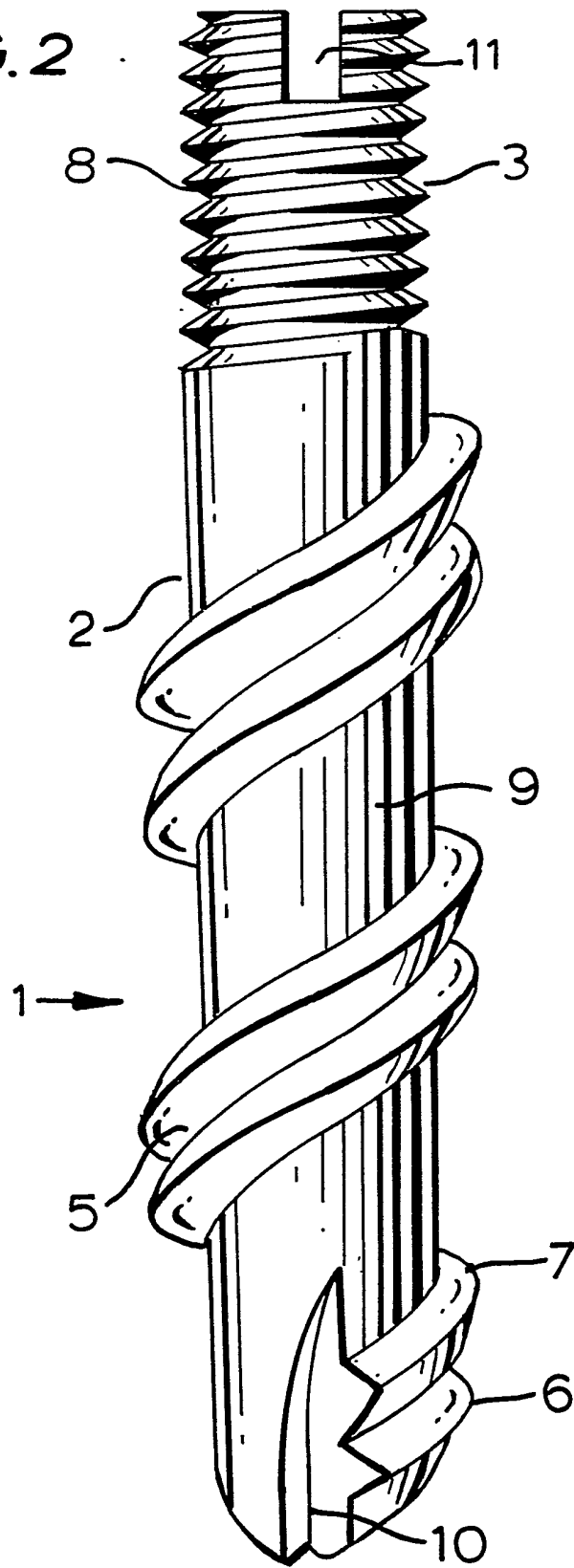
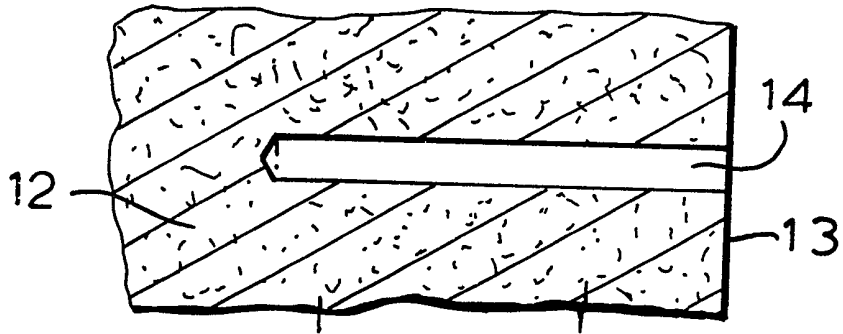
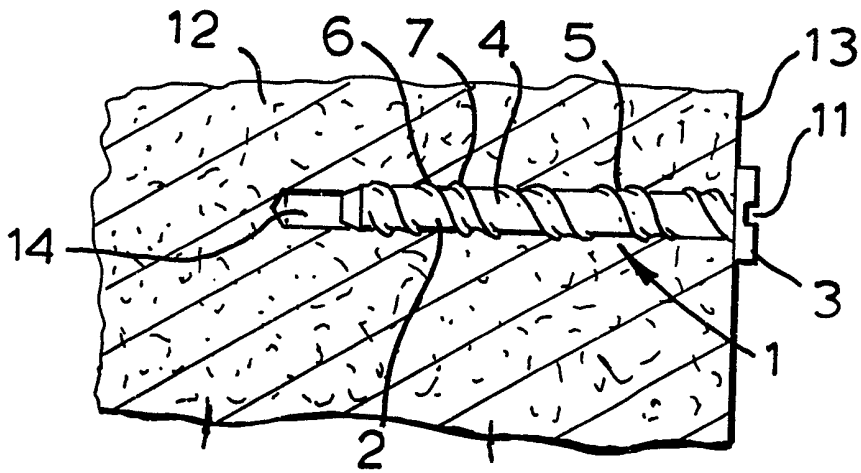

FIG. 3a**FIG. 3b**

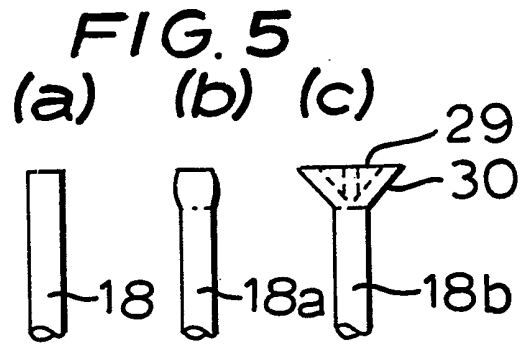
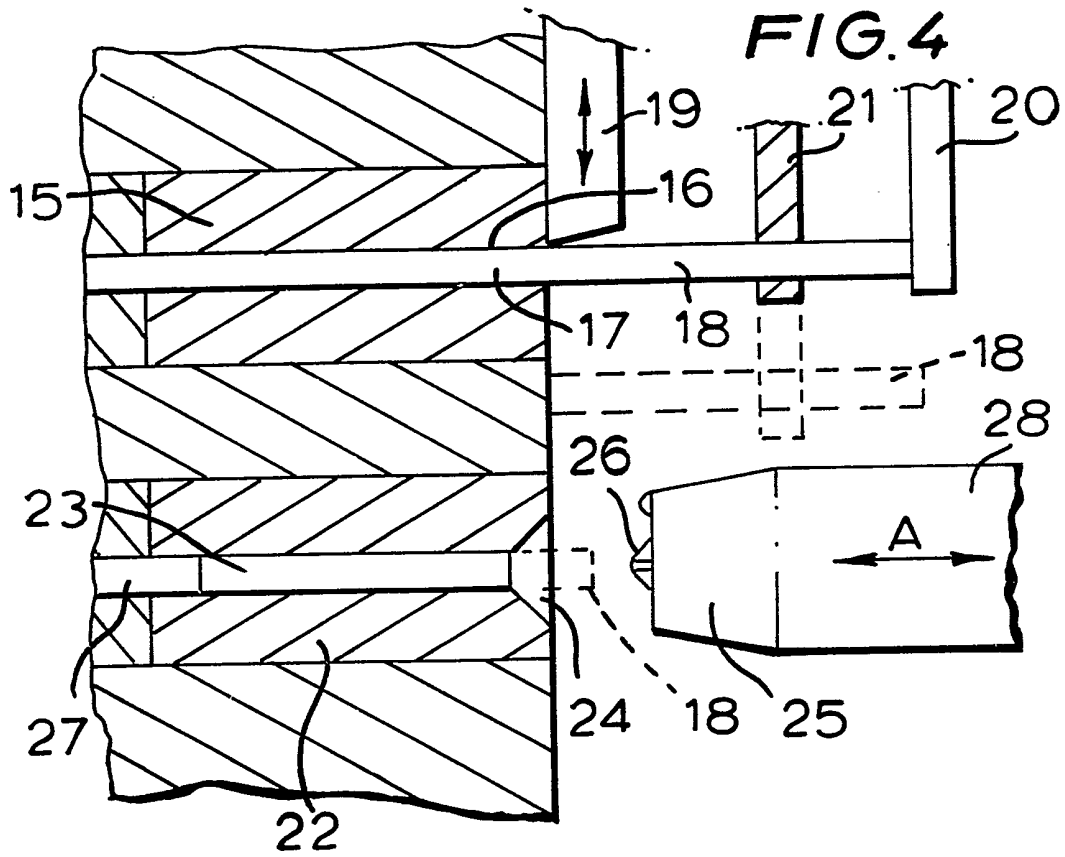

FIG. 6

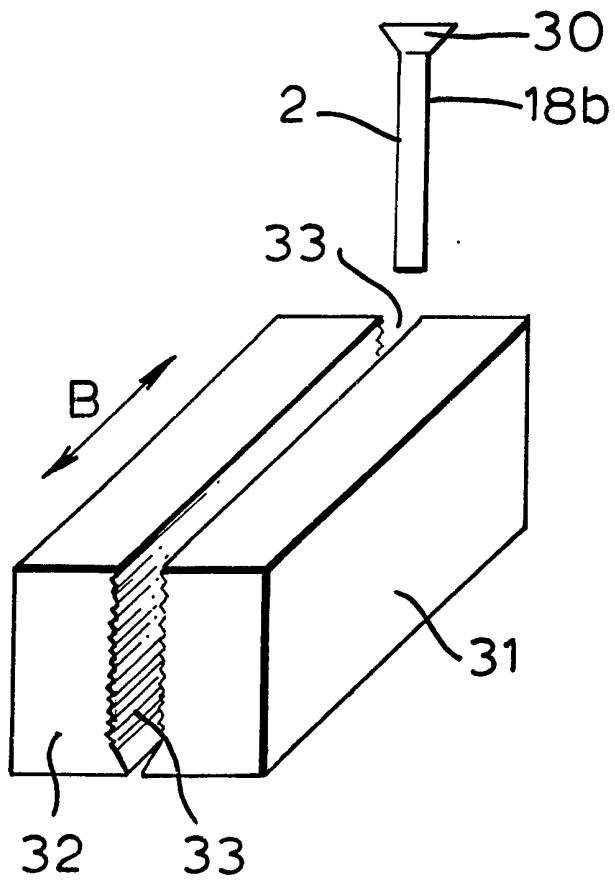

FIG. 7a

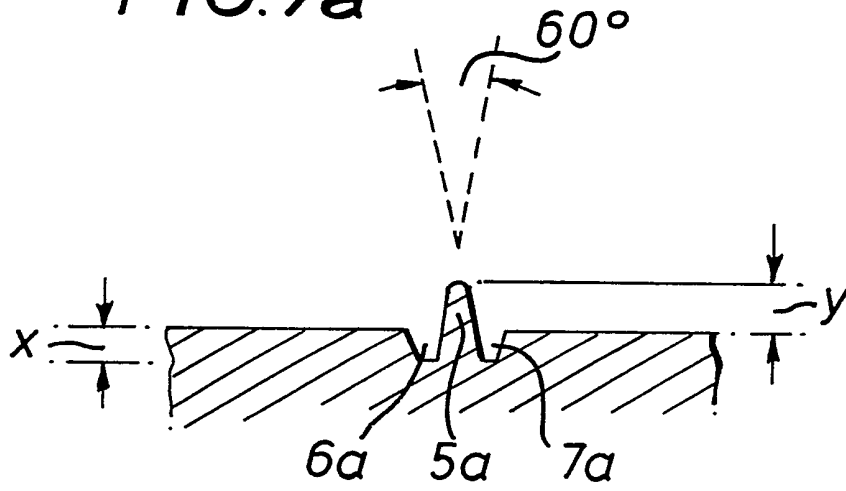

FIG. 7c



FIG. 7b

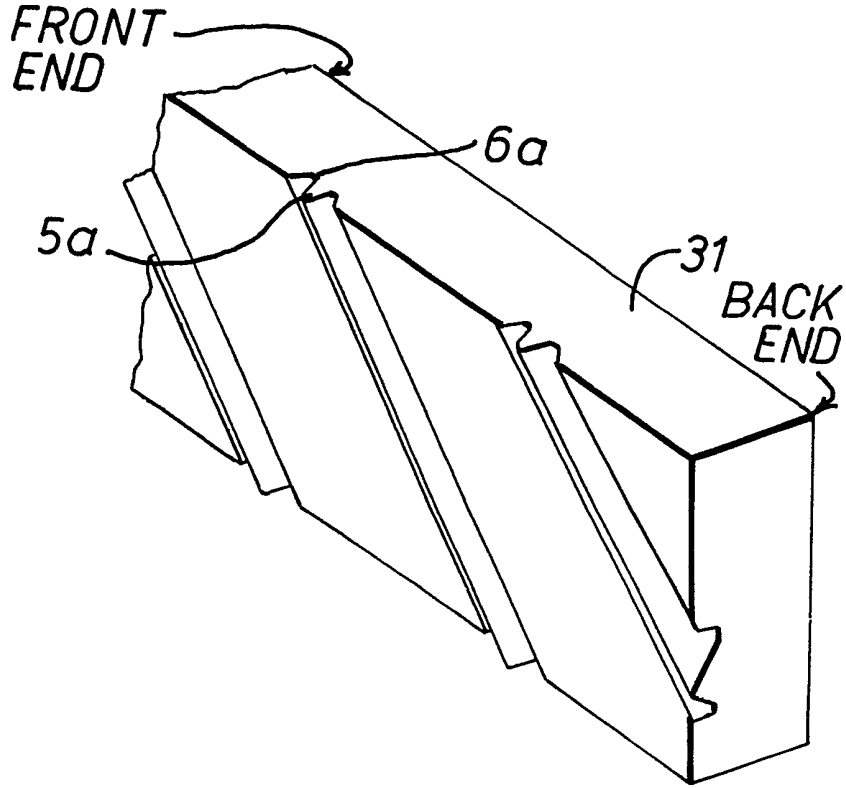
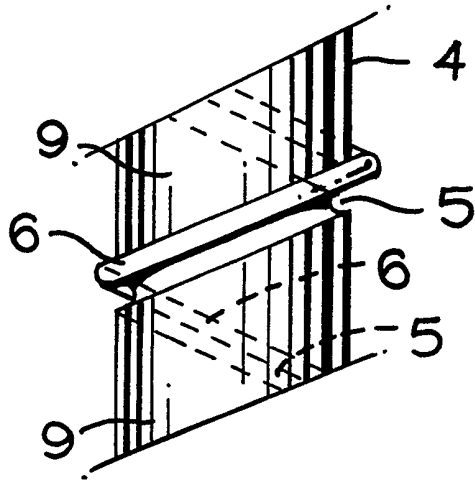

FIG. 8



IMPROVED MASONRY FIXING

The invention relates to methods of fixing applied to masonry or timber substrates and to masonry or timber fixing devices.

5

Conventional threaded fixing devices such as screws are difficult to secure in masonry substrates since it is difficult for a conventional thread to find secure location within a bore in such a substrate. Conventional screw threaded fixings are accordingly conventionally secured within bores in masonry substrates by first lining the bore with a lining of relatively soft material into which the threaded fixing can cut its own thread, at the same time compressing the lining against the walls of the bore within the masonry substrate. A typical example of such a lining is that sold under the trade mark Rawlplug. Such linings are available in fibrous and plastics material form and in a wide variety of configurations reflecting a very considerable activity in the art over the years to improve upon the security and ease of use of screw threaded fixing devices used with such liners.

20

Adopting a somewhat similar principle, alternative forms of fixing device are of metallic material and structured so as to be expansible after introduction into a bore in a masonry material whereby compressive forces against or impingement into the internal surfaces of the bore resist withdrawal of the fixing device from the bore. Reflecting

25

similarly substantial activity in the art, a wide variety of such devices are available. For example, various devices of this kind are available under the above-mentioned trade mark Rawlplug and under the trade mark
5 Fischer.

The Upat TOP self undercutting anchor comprises an internally threaded cylindrical tubular steel sleeve and a cone received in one open end of the sleeve. A splined
10 lower part of the cylindrical sleeve is in contact with the inclined walls of the cone, these walls being divergent in the direction away from the sleeve. The above described assembly is inserted into a pre-drilled bore until the
15 extremity of the cone (ie the base of the conical portion) comes into contact with the end of the bore. Application of light pressure from a hammer drill causes the splined section to be forced over the conical surface, the splines having tungsten carbide tips which undercut the substrate material. The Upat EXA Express Anchor also operates an
20 expansion fixing but does not operate on the undercutting principle.

Fixing devices somewhat similar to those sold under the trade mark Rawlplug are also sold under the trade mark
25 Fischer, as mentioned earlier. Fixing devices are also made by Fischer which are somewhat similar in structure and operation to the above-described Upat fixing elements. The Fischer Wallbolt comprises a segmented malleable iron

expander shield forming a sleeve about an orthodox screw threaded bolt. The combined assembly is in use inserted into a pre-drilled bore in a masonry substrate and the bolt is tightened with a spanner. This draws a terminal conical wedge backwards into the shield and forces four shield segments outwardly against the sides of the bore.

All fixing elements which rely on compression of an associated member into the wall of a pre-drilled bore give rise to structural disadvantages. The walls of the bore are placed under stress and in many substrate materials there is insufficient strength in the substrate structure to prevent cracking. This is particularly the case with such materials as lightweight autoclaved aerated concrete but also applies to brick structures. It is especially evident adjacent apertures in a masonry structure where on one side at least there will be comparatively small thickness of substrate material. Of course, fixing elements are commonly required in aperture regions for the fixing of window frames, door liners and similar fittings.

Equally, a good deal of activity has been focused on improvement of screw threaded members themselves in order that they should find secure fixing in masonry materials without the use of liners and without internal expansion. The driving force in these respects is, of course, the fact that liners do not provide totally satisfactory degrees of security, the fact that the need to insert a liner in a

bore represents an additional activity which has associated labour costs and the fact that in the case of expansion bolts and such like the compressive forces necessary for security of fixing can result, as noted above, in rupture of masonry materials particularly when adjacent to extremities of bodies of such materials.

UK Patent Specifications Nos 2 115 511 (ITW III) and 2 152 171 (ITW II) disclose masonry fixings comprising a shank having spaced threads in the form of a helical ridge alternating with a parallel land. The flanks of the threads intersect at an angle of 50° to 65° and exhibit a helix angle of 6° to 8.5° . These features are necessarily combined with special conditions for introduction into a masonry bore and are claimed to provide security of fixing without thread striping upon insertion. Both ITW II and III represent examples of effort in the art to provide threaded devices for direct securement in a bore so as to avoid the disadvantages of expansion-type devices enumerated above.

Coarse deep threads are also disclosed in a fixing for use in masonry-like structures in UK Patent Specification No 1 510 686 (ITW IV), a further example of an attempt to provide a direct-fixture fixing element. In this particular arrangement, the crests of the deep threads are notched in order to assist in the cutting of a thread by the fixture in use and to assist in the transmission of

masonry debris within the bore. An intermediate shallower thread ridge appears to be the key to providing a design which enables security of fixture to be achieved whilst at the same time recognizing the need to minimize disturbance of the substrate material. Nevertheless, threads penetrate the substrate at fairly closely spaced positions such that pull-out performance is impaired by the shear resistance of the relatively small sections of substrate material between helical ridge turns. A similar arrangement is disclosed in European Patent Application No 0 133 773 (ITW I).

UK Patent Specification No 466039 (Jasper) discloses a fastening screw having a shank provided with a helical thread groove alternating with a land between the grooves. A longitudinal slot provides self-tapping capacity for the course deep thread. Jasper does not disclose the fastening screw for use in masonry structures.

A somewhat similar screw device is described in UK Patent Specification No 274833 (Rosenberg). The entry end screw thread configuration has a groove which penetrates the normal diameter of the fixing device together with raised border ridges, this configuration extending over a short length only of the shank. Rosenberg does not recommend the fixing device for masonry fixing, referring generally to fibrous and non-flowing materials and in particular to metal substrates.

European Patent Specification No 0 225 003 (JSM) and UK Patent Application No 2036227 (Tomoyasu) disclose self-locking screws having a somewhat similar configuration. Helical ridges either side of a small land have their crests grooved. Tomoyasu also refers to a structure in which the ridge crests are not grooved but an intermediate ridge is turned through the land so that there are in fact two parallel grooves forming an overall thread. Both JSM and Tomoyasu relate to self-locking devices reliant on the interaction of male and female threads and there is no disclosure of a use in which the male threaded portion is self-tappingly threadedly into a masonry bore.

UK Patent Specification No 2042120 (Gutshall) discloses a headed screw which incorporates a long-pitch helical thread rolled on a cylindrical blank. The rolling leaves untouched a land between adjacent convolutions of the thread. At each juncture between the root of the thread and the adjacent land a helical crest functioning as an auxiliary thread is provided to improve the holding power of the screw. Gutshall refers to use of the disclosed screw in soft, fibrous or low-density materials which are exemplified as wood and plastics. Gutshall does not appear to recommend the disclosed headed screw for fixture self-tappingly in a masonry substrate.

UK Patent Specification No 1541237 (Oratronics) discloses a threaded device for use as an endodontic stabilizer. The

shank of the disclosed device is turned with a helical groove having a sufficiently wide pitch to provide a parallel inter-turn land. The crest of the ridge is grooved. UK Patent Specification No 1519139 (Crock) discloses a simpler structure for use in surgical techniques. The structure disclosed comprises a threaded shank comprising a thread groove somewhat reminiscent of that shown by Rosenberg as mentioned above. Crock refers skirtingly and somewhat speculatively to application in building construction and associated fields but there is no reference specifically to the use of the disclosed device for self-tappingly securing in a masonry bore.

According to the invention, there is provided in a preferred embodiment a method of fixing to masonry substrates (eg brickwork, blockwork or concrete) wherein a bore is formed in said substrate (eg in the tension zone or compression zone of a concrete load-supporting member such as a concrete beam) and a fixing device is introduced into said bore self-tappingly or otherwise the fixing device comprising a shank having a bore entry end and an opposed optionally headed end separated from the bore entry end by the length of the shank, at least a portion of the shank length being configured with a thread rolled helical groove depressed into the blank circumference of the shank so as plastically to displace shank material to the groove sides, the groove being preferably defined between a pair of parallel helical ridges juxtaposed one either side of the

groove and formed of said plastically displaced shank material, said ridges being upstanding from the blank circumference of the shank so as to function in use each as a male thread, at least the leading end of the thread preferably being a female thread-cutting male thread in relation to the masonry, said helical ridges and defined helical groove forming a shank configuration whose convolutions are spaced apart by an intervening land in relation to which the ridges are raised and the groove is depressed, said land having a width measured axially with respect to the shank of at least 50% of the land shank diameter in preferred embodiments of the invention (and preferably also 4mm as a minimum) and the helix angle of the helical ridge preferably being at least 8° (eg at least 10°). Of course, the ridge/groove shank configuration may alternatively be formed by turning from eg a solid bar, by casting or by any other method and the invention includes fixing devices so made. The land immediately adjacent the aforesaid shank configurations may be configured (at one or both sides) with a recess running helically of the shank and representing a minor depression relative to the helical groove of the said shank configurations. The male thread may be interrupted by cut-outs at least at the tip in order to confer a thread-cutting facility providing for self-tapping performance. The depressed groove in practice serves to contain substrate debris removed by the self-tapping action. The device used in the invention is unusual in providing a method of fixing in a concrete

tension zone; most masonry fixings are designed to operate in the compression zone of concrete members and fail to perform satisfactorily in the tension zone (undercut anchors such as the Upat TOP Anchor being one of a very few exceptions to this).

The fixing device will ordinarily be inserted into a slightly oversized bore (and thus the shank of the device will be slightly undersized in terms of diameter relative to the drill diameter used to produce the bore) in order to avoid an interference fit (which will obstruct threaded insertion).

The shank may be made of a metallic material which is plastically deformable by cold rolling through a die configured to form the helical ridges and helical groove. The shank may, for example, be made of a ferrous metallic material. Although this material may be iron, it is more typically a ferrous alloy such as carbon steel or possibly stainless steel or similar material which resists corrosion through contact with moisture and chemical materials commonly found in masonry structures (eg alkalis). To improve corrosion resistance, the shank may be made of metallic material having a corrosion-resistant finish, for example a coating such as galvanised metallic material.

The ridges conveniently each have a height with reference to the land which is substantially uniform between the

axial extremities of the respective ridge.

Alternatively, the ridges may each include a part length
which is non-uniform in height with reference to the land
5 and which decreases with progression of the respective
ridge helix towards the bore entry end of the shank.

At least the ridges and/or at least the groove may be
coated with a friction-reducing material such as a
10 fluorocarbon polymer although in practice this may be
abraded to the point of removal except in soft masonry
substrates such as light weight autoclaved aerated cement.

In order to facilitate self-tapping, the helix angle of the
15 helical ridge is preferably at least 10° as noted earlier.
Conveniently, the helix angle of the groove will be in the
range 15° to 40° with an angle of 30° or 35° being
preferred.

20 A helix angle of 8° to 10° on a relatively large diameter
shank (eg 22.5mm) will readily provide a land width equal
to the 4mm preferred minimum referred to earlier and thus
when secured in-bore, sections of substrate material of at
least 4mm in axial size between disturbances of the
25 substrate material by the thread of the fixing device.
However, with the objective of providing that the axial
lengths of such material should be a maximum balanced
against the need for adequate radial penetration into the

substrate material to provide thread securement, the inter-space land will conveniently have a width measured axially with respect to the shank of at least 50% of the field shank diameter.

5

Preferably, the land width measured axially of the shank will be about 5mm or more such as in the range 4mm to 25mm (eg 6mm to 15mm) and generally will be 60% to 85% (eg 75%) of the land shank diameter.

10

With the above requirements in mind, the pitch of the groove will generally be between 8 and 14 with a preferred pitch being about 11. The ridges will conveniently be V-cross-section ridges but may have another configuration (for example, a cross-section generally of V-configuration may have a radius at the apex). In the case of V-cross-section ridges, the sides of the ridges at the apices of the ridges subtend with each other an angle of about 60°.

15

20

The shank preferably has a head in the form of a screw-threaded continuation of the shank wherein the thread comprises a helical ridge and a groove extending in parallel so as to present an alternation of ridge turns and groove turns along said continuation. A slot may be provided for drive purposes as may edges defining a hexagon configuration or a depression of hexagonal configuration and, of course, an enlargement may be provided at the head to present any such slot, hexagonal cross-section or

25

hexagonal recess or countersunk or raised countersunk features.

5 In addition to the method defined, the invention includes within its scope any of the fixing devices as hereinbefore defined in connection with the fixing method of the invention.

10 Embodiments of the invention will now be described, by way of example only, reference being made to the accompanying drawings in which:-

Figure 1 shows a first embodiment of fixing device according to the invention;

15

Figure 2 shows a second alternative embodiment of fixing device according to the invention;

20

Figures 3(a) and 3(b) show two stages in the installation of a third embodiment of fixing device according to the invention similar to that shown in Figure 2 in a masonry substrate;

25

Figure 4 shows schematically a screw heading station forming part of a screw production line;

Figures 5(a), 5(b) and 5(c) show various stages in the plastic deformation of a cut off blank wire section in a

screw heading process using the apparatus shown in Figure 4;

5 Figure 6 shows schematically a thread rolling station forming part of a screw production line for use in forming a ridge-groove-ridge configuration according to the invention;

10 Figures 7(a) to 7(c) show the die construction relative to Figure 6 in greater detail; and

Figure 8 is a single ridge version of the embodiment shown in Figure 1.

15 The fixing devices shown in Figures 1, 2 and 3 are designated generally by the reference numeral 1 (and the same applies to Figure 8). In the Figures, like parts are designated by like reference numerals.

20 The fixing device shown in Figure 1 comprises (and similarly in Figure 8) a steel shank 2 of solid right circular cylindrical configuration comprising an upper section 3 and a lower section 4. Lower section 4 has a groove 5 formed in the surface of the blank shank by cold
25 thread rolling. Groove 5 has a helical configuration and extends spirally around the circumference of the lower section 4 of shank 2 and is co-extensive longitudinally with that section.

Groove 5 is defined between two parallel marginal ridges 6 and 7 (one of which is absent in favour of one ridge and a deeper groove in the case of Figure 8), formed of shank material displaced from the groove 5 by the plastic deformation which occurs during thread rolling.

Upper section 3 of shank 2 is formed with a conventional male screw thread 8 to enable threaded engagement of articles to the fixing element 1 when the fixing element 1 is secured in a masonry structure.

The axial extremities of the shank 2 are formed having regard to the practicalities of the fixing device 1 in use. Thus, for example, the extremity of the lower portion 4 of shank 2 has a frustoconical configuration to assist bore entry of that extremity. The extremity of the upper portion 3 of shank 2 has a domed configuration and is provided with a screwdriver engagement slot, cross-recess, hexagon or square drive (not shown) or screw head enlargement such as one configured with a countersink.

It will be noted that a land 9 is provided between the turns of the ridge-groove-ridge configuration. In the embodiment shown in Figure 1, the land has a width between turns as measured axially of the shank 2 of 10mm. The shank field diameter in the example depicted is 10.4mm and the pitch of the groove 5 is 14mm, the helix angle of the

spiral being 30°. The groove depth relative to the field level is 0.5mm and the ridge height relative to the field level is 1.0mm. Of course, fixing devices conforming generally to the embodiment described may be configured with different values for one or more of the above parameters.

Turns 6(a) and 7(a) of ridges 6 and 7 are configured by means not shown to provide a self-tapping capacity in a masonry structure.

The fixing device embodiment shown in Figure 2 is broadly similar to that shown in Figure 1. However, in this embodiment the thread represented by the ridge-groove-ridge turns is much coarser and the in-bore extremity of the shank 2 is slotted by means of slot 10 to provide for self-tapping. The device of Figure 2 is preferred over that of Figure 1.

Threaded upper section 3 has a flat top provided with screwdriver engagement slot 11. The remaining features of the fixing device shown in Figure 2 will be readily understood from the Figure itself, in comparison with Figure 1, like parts being designated by like reference numerals.

Figure 3a shows diagrammatically a masonry substrate whose surface 13 is perforated by a right circular

cylindrical bore 14 drilled into the masonry substrate 12 using a low speed power driven masonry drill bit without hammer action (although, of course, hammer drilling or rotary impact drilling may be adopted as an alternative).

5 In use of fixing devices according to the invention, the first stage in procedures to install the fixing device in a masonry structure is to drill a bore such as that depicted at 14 in Figure 3(a).

10 A fixing device according to the invention, such as that shown in Figure 1 or Figure 2 of the drawings, is offered up to the bore 14 and its extremity remote from the extremity configured for screwdriver engagement is inserted into the mouth of the bore 14. The fixing element is then
15 rotated manually number of times until the threads 6, 7 start to engage by tapping a corresponding female thread in the outer portions of the wall of the bore 14. This practise is continued until finger turning becomes impractical. A screwdriver is then taken by the operator,
20 engaged with the other extremity of the shank 2 by means of the slot provided for the purpose and further turning effected. The thread represented by ridges 6, 7 continues with this motion to form its own female thread with gradually increasing extent along the length of the
25 internal surface of bore 14 until all of the lower portion 4 of shank 2 is received in the bore 14. This stage is depicted in Figure 3(b) where it will be seen that a slightly different embodiment of the fixing device

according to the invention is shown in place. The fixing element shown in Figure 3(b) is one having a coarse thread sharper than that shown in Figure 1. Self-tapping grooves 10 traverse the ridge-groove-ridge configurations providing a thread-cutting facility along the length of the shank 2 analogously to the slot 10 shown in Figure 2.

Tabulated in Table 1 below are parameters for three specific examples of fixing device according to the invention corresponding, respectively, to the embodiments shown in Figures 1, 2 and 3(b) of the drawings:-

Table 1

Embodiment	Diameter (mm)	Groove Pitch	Helix (°)	Land Width (mm)	Groove Depth (mm)	Ridge Height (mm)
Figure 1	10.4	11	25	7	0.5	0.5
Figure 2(a)	10.4	14	30	10	0.5	1.5
Figure 3(b)	6.36	11	25	6.7	0.5	1.0

In Table 1, land width is measured between adjacent spaced ridges axially of the shank. Groove depth is measured

relative to the level of the land and ridge height also is measured relative to the level of the land.

5 The following specific Example is intended to illustrate use and performance of fixing elements according to the invention relative to various prior art fixing devices:-

Example

10 A number of fixing elements were tested in brickwork as set out at A to H in Table 2.

Bores of diameters 8mm, 10mm, 12mm and 14mm were pre-drilled in solid brick having a compressive strength of 20.5N/mm² (A to E, G and H) or of 15N/mm² (F) to various depth as recommended by the manufacturer or 5mm in excess of fixing device length using, for example, a conventional drill bit of appropriate size driven by a slow speed power drill without hammer action (a hammer action could equally be used).

15

20

Fixing elements, shorter than the bore depths, of various types and having diametric sizes of 6mm, 8mm, 10mm and 12mm were then selected as noted in Table 2 below and matched on the basis bore/element = 8/6, 10/8, 12/10 and 14/12 except as stated otherwise.

25

Matched elements were then introduced, to extents shown in

Table 2, into matched bores.

Pull-out strengths (ie ultimate tensile strengths) were then determined by applying calibrated loads axially to the fixing elements in the direction of withdrawal. The results are shown in Table 2 and readily demonstrate at least comparable performance as compared to some multi-component devices (Rawlbolt), whilst as compared to bore liners. (Fischer Nylon Plug, Upat Ultra Plug) and direct fixtures (Rawl Spike), performance was superior. Expansion bolts, of course, suffer from disadvantages in terms of material costs, risk of substrate rupture and slower speed of installation.

Table 2

Fixing Device	DA mm	Hole Depth mm	Thread Dia mm	Hole Shank/ Length mm	Fixing Depth mm	Ultimate Embedment Strength KN	Tensile Substrate Type	Comments
Rawlbolt								
M6	12	50	M6	45	45	9.2	20.5N/MM ² Brick	Multi Component Product
M8	14	55	M8	50	50	11.35	"	
M10	16	65	M10	60	60	14.35	"	
M12	20	85	M12	75	75	21.5		
SFS Spike								
4.8	4.8	40	4.8	32	22	2.0	20.5N/MM ² Solid	Brick
Rawl Spike								
5.0	5.0	40	5.0	40	32	3.6	"	
6.5	6.5	40	6.5	40	32	4.3		
Fischer								
Nylon Plug								
S6	6	40	5	30	30	2.5	Solid Brick	Plug & Screw
S8	8	55	6	40	40	4.1	Fixing	
S10	10	70	8	50	50	4.4		
S12	12	80	10	60	60	4.5		
Nylon Plug								
S6	6	40	5	30	30	2.2	Perforated Brick	Plug & Screw
S8	8	55	6	40	40	3.0		
S10	10	70	8	50	50	4.6		
S12	12	80	10	60	60	4.7		
UPAT Ultra Plug								
U6	6	40	5	30	30	.5		Plug & Screw
U8	8	55	6	40	40	.8		
U10	10	65	8	50	50	1.1		
U12	12	75	10	60	60	1.5		
UPAT Ultra Plug								
U6	6	45	6	40	30	7.0	Solid Brick	
U10	10	55	10	50	40	12.5		

Referring to Figure 4, a screw heading station comprises a solid metallic block 15 formed with a right circular cylindrical uniform diameter bore 16. Steel wire 17 passes along bore 16 and is urged until its end abutts against stop 20. A cut-off knife 19 is mounted for reciprocatory motion radially across the mouth of bore 16 so as to sever the wire 17 to form a blank 18. A transfer finger mounted for reciprocatory motion parallel to that of cut-off knife 19 is provided for transferring cut off blank 18 a stage further in the heading operation as depicted at two points in Figure 4 in broken lines. At the maximum displacement of transfer finger 21, blank 18 is disposed in register with a bore 23 in solid metallic block 22, bore 23 being identical with bore 16 in block 15 except that bore 23 has a blind end represented by the crown of a piston 27 moveable axially of bore 23 to provide for different desired lengths of fixing element. Whilst retained by transfer finger 21, blank 18 is displaced into bore 23 in block 22 by means of a first of two punches 25 mounted for reciprocatory motion in the directions of double headed arrow A shown in Figure 4.

The mouth 24 of bore 23 is depressed into the body of block 22 and has the configuration of a countersink. The first of punches 25 drives blank 18 fully into bore 23 and produces the partial plastic deformation shown in Figure 5(b). The first punch 25 is provided with a plane punch face 28. The second punch 25 is provided with a punch face

28 having a structure 26 disposed thereon for forming in
the head of the fixing device a screw engagement depression
29 having a so-called Posidrive configuration. The action
of the second of the two punches 25 completes plastic
5 deformation of the terminal end of blank 18 to form the
head 30 shown in Figure 5(c).

The thread rolling station shown in Figures 6 and 7
comprises a fixed die 31 and a displaceable die 32. The
10 two dies are spaced apart to form jaw 33, the gap there
between being equal to the core diameter of the product
being rolled. Die 32 is displaceable in reciprocatory
fashion according to the arrow B shown in Figure 6. In
use, headed blank 18b is inserted into jaw 33 and thus
15 between the fixed and moving dies 31, 32 by manual or
mechanical means (eg a mechanical feed finger) as is known
in the thread rolling art. The vertical position of the
blank in relation to the fixed and moving die is governed
by a work rest on which the blank 18b rests prior to
20 introduction to the dies by the feed finger. The
operational sequence is for the moving die to move clear
of being parallel with the fixed die 31 in the direction of
arrow B. Blank 18b is then transferred by the feed finger
into the work rest and pushed against and between the
25 leading edge of moving die 32 and the back edge of fixed
die 31. The reciprocating action of the moving die 32 then
carries the blank 18b between them, during which time the
blank 18b is plastically deformed to the face of the dies,

as the blank rolls along the faces thereof, to form ridge-groove-ridge convolutions as depicted in Figures 1, 2 and 3(b); a die groove corresponding to a ridge on the fixing element is shown at 6a and another at 7a whilst ridge 5a
5 corresponds to groove 5 of the fixing element.

As compared to two-part fixing systems, fixing elements according to the invention provide efficiency of installation and greater security of fixture in terms of
10 pull-out strength. As shown in Table 2 hereinbefore, pull-out strength performance at least in brick is superior to most expansion bolts and plastics fixings in brickwork. The fixing devices according to the invention provide secure fixture in bores in masonry substrates ranging from
15 brick, light-weight aerated autoclaved cement blockwork and various forms of concrete without the problems associated with expansion bolts due to the risk of rupture of the substrate material. Fixing elements according to the invention can also easily be manufactured by the steps of
20 cold forging and thread rolling, bright zinc plating and heat treatment without resort to complex assembly operations such as are normally associated with an expansion bolt. This produces economics in terms of materials and manufacturing costs as well as the economics
25 associated with relative ease of installation.

The invention as described earlier without reference to the drawings may include any one or more features of the

invention described with reference to drawings.

Claims

1. A method of fixing to masonry or timber substrates wherein a bore is formed in said substrate and a fixing device is introduced into said bore self-tappingly, the fixing device comprising a shank having a bore entry end and an opposed optionally headed end separated from the bore entry end by the length of the shank, at least a portion of the shank length being configured with a thread rolled helical groove depressed into the blank circumference of the shank so as plastically to displace shank material to at least one of the groove sides, the groove being defined adjacent a helical ridge juxtaposed to the side of the groove or between a pair of such ridges one either side thereof and formed in either case of said plastically displaced shank material, said ridge(s) being upstanding from the blank circumference of the shank so as to function in use as male thread, at least the leading end of the thread being a female thread-cutting male thread in relation to the masonry, said helical ridge(s) and defined helical groove forming a shank configuration whose convolutions are spaced apart by an intervening land in relation to which the ridge(s) is raised and the groove is depressed, said land having a width measured axially with respect to the shank of at least 4mm and at least 50% of the land shank diameter, and the helix angle of the helical ridge being at least 10°.

2. A method as claimed in Claim 1 wherein the shank is made of a metallic material which is plastically deformable by cold rolling through a die set configured to form the helical ridge(s) and helical groove.

5

3. A method as claimed in Claim 1 or Claim 2 wherein the or each of the ridges has a height with reference to the land which is substantially uniform between the axial extremities of the respective ridge.

10

4. A method as claimed in Claim 1 or Claim 2 wherein the or each of the ridges includes a part length which is non-uniform in height with reference to the land and which decreases with progression of the respective ridge helix towards the bore entry end of the shank.

15

5. A method as claimed in any preceding claim wherein the shank is made of ferrous metallic material.

20

6. A method as claimed in Claim 5 wherein the metallic material is a ferrous alloy.

7. A method as claimed in Claim 6 wherein the ferrous alloy is stainless steel.

25

8. A method as claimed in Claim 5 or Claim 6 wherein said shank is made of metallic material having a corrosion-resistant coating.

9. A method as claimed in Claim 8 wherein the shank is made of galvanized metallic material.
- 5 10. A method as claimed in any preceding claim wherein at least the ridge(s) and the groove are coated with a friction-reducing material.
- 10 11. A method as claimed in Claim 10 wherein the friction-reducing material is fluorocarbon polymer.
12. A method as claimed in any preceding claim wherein the pitch of the groove is between 8 and 14.
- 15 13. A method as claimed in Claim 12 wherein the pitch of the groove is about 11.
14. A method as claimed in any preceding claim wherein the helix angle of the groove is from 15° to 40°.
- 20 15. A method as claimed in Claim 14 wherein the helix angle of the groove is about 35°.
16. A method as claimed in any preceding claim wherein the ridge(s) is a V-cross-section ridge.
- 25 17. A method as claimed in Claim 16 wherein sides of the ridge(s) at the apices of the ridge(s) subtend with each

other an angle of about 60°.

18. A method as claimed in any preceding claim wherein
the shank has a head in the form of screw threaded
5 continuation of the shank wherein the thread comprises a
helical ridge and groove extending in parallel so as to
present a continuous alternation of ridge turns and groove
turns along said continuation.

10 19. A method as claimed in Claim 1 wherein the fixing
device is substantially as hereinbefore described with
reference to and as illustrated in the accompanying
drawings.

15 20. A method a claimed in Claim 1 and substantially
as hereinbefore described with reference to and as
illustrated in the accompanying drawings.

20 21. A fixing device as defined in any preceding
claim.

-29-

Patents Act 1977
Examiner's report to the Comptroller under
Section 17 (The Search Report)

Application number
 9120729.0

Relevant Technical fields

- (i) UK CI (Edition K) F2H (HAA, HM)
 (ii) Int CL (Edition 5) F16B 25/00 25/02

Search Examiner
 P M WELLER

Databases (see over)

- (i) UK Patent Office
 (ii) ONLINE DATABASES: WPI

Date of Search
 7 APRIL 1992

Documents considered relevant following a search in respect of claims 1-21

Category (see over)	Identity of document and relevant passages	Relevant to claim(s)
X	GB 2042120 A (GUTSHALL) Figures 2, 4	1
X	GB 1452955 A (UPAT-MAX) Figure 3	1

Category	Identity of document and relevant passages	Relevant to claim(s)

Categories of documents

X: Document indicating lack of novelty or of inventive step.

Y: Document indicating lack of inventive step if combined with one or more other documents of the same category.

A: Document indicating technological background and/or state of the art.

P: Document published on or after the declared priority date but before the filing date of the present application.

E: Patent document published on or after, but with priority date earlier than, the filing date of the present application.

&: Member of the same patent family, corresponding document.

Databases: The UK Patent Office database comprises classified collections of GB, EP, WO and US patent specifications as outlined periodically in the Official Journal (Patents). The on-line databases considered for search are also listed periodically in the Official Journal (Patents).