

Fig. 1

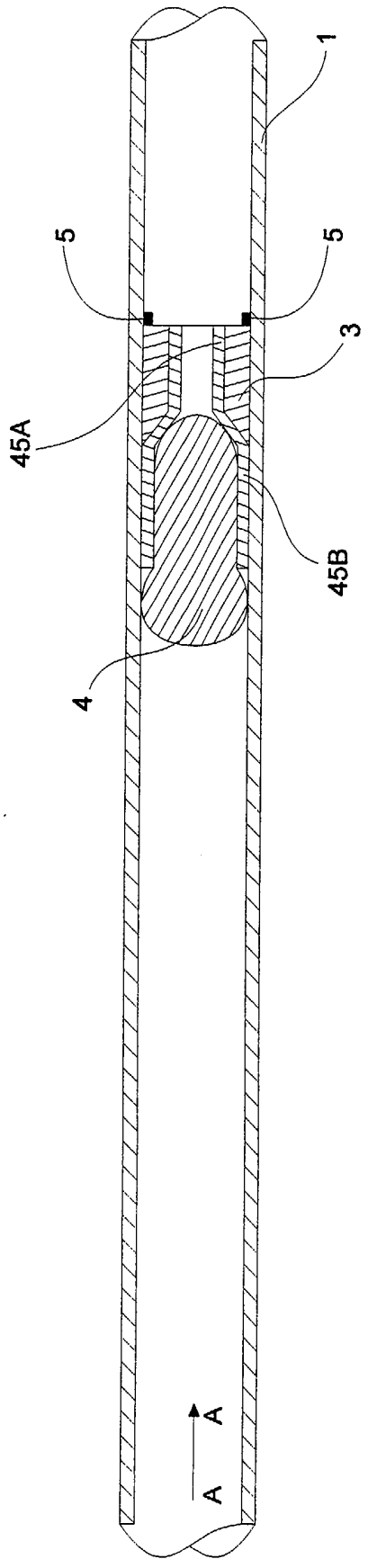

Fig. 2

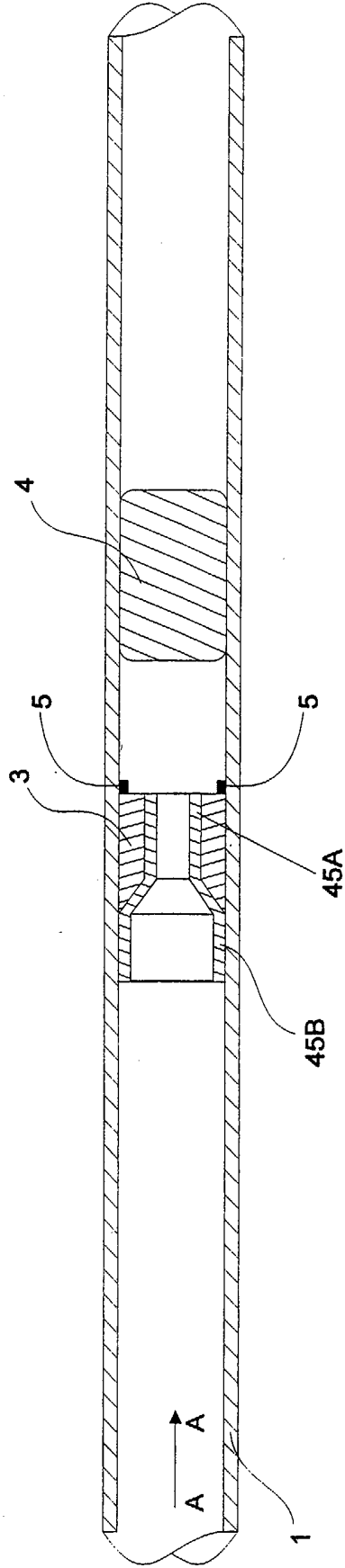

Fig. 3

**"METHOD OF DIMINISHING THE CROSS SECTION OF AN OPENING OF A
HOLLOW DEVICE LOCATED IN A FLOW PIPE".**

FIELD OF THE INVENTION

The present invention is related to a method to diminish the cross section of
5 an opening of a hollow device located in a flow pipe using flexible pigs to engage a
second hollow device with a first hollow device which has been previously set into the
flow pipe, thereby achieving a reduction in the cross section of the opening through
which pass the fluids flowing through the pipe. The proposed method is particularly
suited to be used in an undersea pipe flow.

10 STATE OF THE ART

Pipes are widely used in the industry to transport diverse kinds of fluids. Such
fluids may comprise a single constituent or multiple constituents, they may comprise
a single phase or multiple phases, and they may be highly compressible or they may
be almost not compressible. Such pipes may be provided with varying internal
15 diameters and configurations. In the oil industry the pipes, or flow pipes, as they are
usually referred to, are used to promote the flow of fluids from oil producing wells
to gathering centres, where the fluids are processed.

When an undersea oil field is commercially exploited, it is necessary for the
production from the oil producing wells to flow through pipes to a production unit
20 located at the surface. An undersea flow pipe is usually connected at one end to an
oil producing well and lies down on the sea bed but is connected at its other end to
an undersea flow riser, which carries the fluids to the production unit at the surface.

Situations may occur in which it is necessary to insert a hollow device into the
undersea flow pipe, in a certain location. Such device can for example be a body,
25 externally shaped to match the inside of a portion of the undersea flow pipe where
it is to be located with an orifice of any shape extending longitudinally therethrough
so as to provoke a constriction in the flow.

The object of the insertion of such device into the undersea flow pipe may be,

for example, to introduce a constriction in the flow to control the features of this flow, or to introduce an element intended to be used in flow rate measuring operations. In the oil industry situations occur in which there is the need to control the phenomenon known as severe slugging, which may occur in production systems provided with descending flow pipes followed by flow risers.

The severe slugging phenomenon is characterised by intense oscillations in the pressure and flow rate levels occurring in a multiphase flow having a gaseous phase. The severe slugging phenomenon causes disturbances to the undersea production activities, which can seriously impair or even shut the oil production down.

GB 2 341 695, commonly owned by the applicants of the present patent application, discloses a device used to control the severe slugging phenomenon. A hollow device, preferably a venturi, is installed into a descending undersea flow pipe relatively close to the junction to a flow riser.

The design of new undersea flow pipe may anticipate the need of such hollow device, which can be installed during the deployment of the undersea flow pipe. In existing undersea flow pipes where access to the interior of the undersea flow pipe is easy and the oil production flow can be interrupted, the hollow device can be installed after cutting the undersea flow pipe, the integrity of the undersea flow pipe being reinstated by using any of the known pipe assembling techniques, e. g., welding.

However, besides causing ceasing of profits, shutting down of the production can cause many operational problems, especially in undersea flow pipe under the effects of low temperatures of the sea bed. Many of these undersea flow pipes are located at great depth of sea, hindering the access of divers. A cutting operation in such undersea flow pipe would be very difficult to implement, as it involves the retrieval of the undersea flow pipe from the seabed, or carrying out the operation using a remote operated vehicle, both being extremely expensive, time consuming and complex operations.

Thus, there has been a need to provide a way to install a hollow device as described in GB 2 341 695 in undersea flow pipe without causing the above drawbacks. The present invention propose the use of polymeric foam blocks to set the

hollow device in its operational position.

The British patent application 0102331.6, of 30 January 2001, commonly owned by the applicants of the present patent application, discloses a method to set a hollow device into an undersea flow pipe using flexible pigs, preferably foam pigs formed from polymeric foam. The word "pig" is used here to denote devices which are inserted into a pipe and which are urged therealong by the flow in that pipe, usually to clean the interior of the pipe.

Situations may occur which, for any reason, it is necessary to diminish the size of the cross section of the passage of the opening of a hollow device already installed in an undersea flow pipe. For this, it would then be necessary to retrieve the existing first hollow device and next to set in its place a second hollow device having an opening whose cross section is smaller than the cross section of the opening of the first hollow device.

In such case it would be necessary to pass a first pig into the undersea flow pipe, to remove the first hollow device, and next to pass a second pig to set the second hollow device. These operations are expensive and time consuming, therefore increasing the costs of the operation.

The present invention proposes a novel method to diminish the size of the cross section of the opening of a hollow device through which fluids from a flow in an undersea pipe flow pass, thereby overcoming the above drawbacks.

SUMMARY OF THE INVENTION

The present invention relates to a method to diminish the cross section of the opening of a first hollow device previously set into a flow pipe, through which a fluid flow flows, the method comprising the steps of:

- first inserting a second hollow device at an end of said flow pipe located upstream of a point where said first hollow device operates, said second hollow device being provided with a trailing portion having such an external diameter that it can be sealingly set into said flow pipe, and having a leading portion having an external diameter smaller than the external diameter of said trailing

portion, said leading portion being able to be inserted into into said opening of the first hollow device;

- next inserting a driving means immediately after said second hollow device;

5 - allowing said driving means to be urged by said flow in said flow pipe, thereby displacing said second hollow device along said flow pipe towards said first hollow device;

10 - when said second hollow device encounters said first device, allowing said smaller diameter leading portion of the second hollow device to be progressively longitudinally inserted into said opening of the first hollow device, until said greater external diameter trailing portion of the second device contacts the body of said first hollow device, thereby stopping the displacement of said second hollow device; whereby said leading portion of the second hollow device will be fully inserted into said opening of the first hollow device; and

15 - allowing said driving means to pass through a passage in said second hollow device, urged by a pressure exerted by said flow.

Preferably the driving means is a flexible pig.

BRIEF DESCRIPTION OF THE DRAWINGS

20 The invention will be now described in more detail together with the attached drawings which, for illustration only, accompany the present specification, wherein:

Figure 1 is a longitudinal cross section view of an undersea flow pipe depicting a second hollow device being urged by a foam pig towards a first hollow device previously set into the undersea flow pipe;

25 Figure 2 is a longitudinal cross section view depicting the second hollow device being set into the first hollow device; and

Figure 3 is a longitudinal cross section view depicting the foam pig just after having passed through the second hollow device, after the latter has been set into the first hollow device.

DETAILED DESCRIPTION OF THE INVENTION

In Figure 1 a first hollow device 3 is located at a certain point of an undersea flow pipe 1, and kept in position by stop means 5. A second hollow device 45 is being urged by a foam pig 4 towards the wider end of the first device 3.

5 In Figure 2 the second hollow device 45 has already reached and entered the first hollow device 3. As can be seen in the Figure 2, the cylindrical trailing portion 45B of the second hollow device 45 is provided with such an external diameter that it can be sealingly set into the undersea flow pipe 1, and the leading portion 45A, in this case also cylindrical, is provided with a diameter which is smaller than the
10 external diameter of the trailing portion 45B. The external diameter of the leading portion 45A of the second hollow device 45 is such that it can engage in the opening of the first hollow device 3.

When the second hollow device 45 reaches the first hollow device 3 the leading portion 45A starts to be longitudinally inserted into the opening of the first
15 hollow device 3, and it will be housed there after the trailing portion 45B of the second hollow device 45, of a larger external diameter, has abutted the first hollow device 3. Preferably, the longitudinal length of the trailing portion 45B of the second hollow device 45 may be substantially equal to the longitudinal length of the first hollow device 3.

20 The foam pig 4 will then pass throughout the opening of the second hollow device 45 and will go on travelling in the undersea pipe flow 1, as shown in Figure 3, in order to be retrieved by means of any retrieval device well known in the art. However, it is not necessary that the foam pig 4 keep its physical integrity after passing through the opening of the second hollow device 45; it can be destroyed when
25 passing through the opening.

The above described method enables the cross section of the opening of a first hollow device to be diminished without the need to replace such first hollow device by a second hollow device having an opening of smaller internal diameter than that of the first hollow device, and only a single flexible pig is used to carry out the
30 whole diminution operation.

While a foam pig has been proposed here to be used for setting a hollow device into its operating position, any other kind of pig, or even any other suitable means, can be used, providing that it is able to pass throughout the opening of the hollow device after the latter has been set.

5 It must be mentioned here that although the present invention has been described with respect to a hollow device located in an undersea flow pipe, this is only one particular situation, as the present method may be used in any situation where there is a need to diminish the size of the cross section of the opening of a hollow device located in a pipe, be it at an undersea environment or not.

10 Those skilled in the art will immediately notice that modifications can be introduced in the method disclosed herewith without departing from the scope and the spirit of the present invention.

 Having described the present invention with respect to its preferred embodiment, it should be mentioned that the above description should not be taken
15 as limiting the present invention, which is limited only by the scope of the appendant claims.

CLAIMS

1. A method of diminishing the cross section of the opening of a first hollow device previously set into a flow pipe, through which a fluid flow flows, the method comprising the steps of:
 - 5 - first inserting a second hollow device at an end of said flow pipe located upstream of a point where said first hollow device operates, said second hollow device being provided with a trailing portion having such an external diameter that it can be sealingly set into said flow pipe, and having a leading portion having an external diameter smaller than the external diameter of said trailing portion, said leading portion being able to be inserted into into said opening of
10 the first hollow device;
 - next inserting a driving means immediately after said second hollow device;
 - allowing said driving means to be urged by said flow in said flow pipe, thereby displacing said second hollow device along said flow pipe towards said first
15 hollow device;
 - when said second hollow device encounters said first device, allowing said smaller diameter leading portion of the second hollow device to be progressively longitudinally inserted into said opening of the first hollow device, until said greater external diameter trailing portion of the second
20 device contacts the body of said first hollow device, thereby stopping the displacement of said second hollow device; whereby said leading portion of the second hollow device will be fully inserted into said opening of the first hollow device; and
 - allowing said driving means to pass through a passage in said second hollow
25 device, urged by a pressure exerted by said flow.
2. A method according to Claim 1, wherein the longitudinal length of said leading portion of the second hollow device is substantially equal to the longitudinal length of said first hollow device.

3. A method according to either of Claims 1 and 2, wherein said flow pipe is an undersea flow pipe.
4. A method according to any one of Claims 1 to 3, wherein said driving means is a flexible pig.
- 5 5. A method according to claim 4 wherein said flexible pig is a foam pig.
6. A method of diminishing the cross section of the opening of a first hollow device previously set into an undersea flow pipe through which a fluid flow flows, substantially as described herein with reference to and as illustrated in the accompanying drawings.



INVESTOR IN PEOPLE

Application No: GB 0103055.0
Claims searched: 1-6

Examiner: Dr. Lyndon Ellis
Date of search: 10 May 2001

Patents Act 1977 Search Report under Section 17

Databases searched:

UK Patent Office collections, including GB, EP, WO & US patent specifications, in:

UK Cl (Ed.S): E1F FAC, FHU, FJB
G3H HAA

Int Cl (Ed.7): E21B, F15D

Other: Online: EPODOC, WPI, JAPIO

Documents considered to be relevant:

| Category | Identity of document and relevant passage | Relevant to claims |
|----------|---|--------------------|
| A | GB 2280460 A (Altra) | - |
| A | US 6006828 (Sensor) | - |
| A | WO 97/39273 A1 (Petroleo) | - |

| | | | |
|---|---|---|--|
| X | Document indicating lack of novelty or inventive step | A | Document indicating technological background and/or state of the art. |
| Y | Document indicating lack of inventive step if combined with one or more other documents of same category. | P | Document published on or after the declared priority date but before the filing date of this invention. |
| & | Member of the same patent family | E | Patent document published on or after, but with priority date earlier than, the filing date of this application. |