

(21) Application No: 1512015.7
(22) Date of Filing: 15.03.2013
Date Lodged: 08.07.2015

(86) International Application Data:
PCT/US2013/032276 En 15.03.2013

(87) International Publication Data:
WO2014/143001 En 18.09.2014

(51) INT CL:
B22F 7/00 (2006.01) C22C 1/05 (2006.01)
E21B 10/46 (2006.01)

(56) Documents Cited:
WO 2012/073099 A2 US 5373907 A
US 4113473 A US 20100278604 A1
US 20080127781 A1

(58) Field of Search:
INT CL B21K, B22D, B22F, B23D, C22C, E21B
Other: eKOMPASS

(71) Applicant(s):
Halliburton Energy Services, Inc.
(Incorporated in USA - Delaware)
10200 Bellaire Boulevard, Houston,
Texas 77072-5299, United States of America

(72) Inventor(s):
William Brian Atkins
Jeffrey Thomas

(74) Agent and/or Address for Service:
Hoffmann Eitle
Harmsworth House, 3rd Floor, 13-15 Bouverie Street,
LONDON, EC4Y 8DP, United Kingdom

(54) Title of the Invention: **Directional solidification of polycrystalline diamond compact (PDC) drill bits**
Abstract Title: **Directional solidification of polycrystalline diamond compact (PDC) drill bits**

(57) A method of manufacturing a rotary drill bit includes forming a mold having an inner surface and an outer surface, locating a metal mandrel within the mold, packing the mold around at least part of the mandrel with particulate matrix-forming material and installing an insulating material around at least an upper portion of the outer surface. The material is infiltrated in a furnace with a molten binding alloy and the mold including the insulating material is removed from the furnace, directionally solidifying the material and binding alloy in portion of said bit, wherein said directional solidification proceeds from the lower portion of the outer surface in an upward and outward direction to form a solid infiltrated matrix bonded to the mandrel by cooling of the mold with the insulating material disposed around at least the upper portion of the outer surface of the mold.

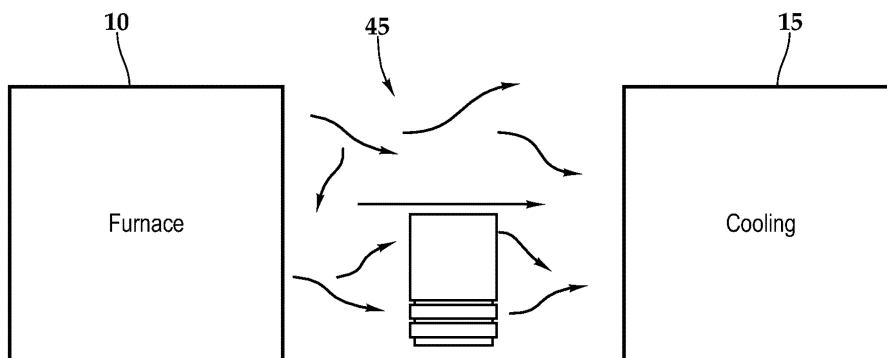

Fig.1