

(21) Application No: 1617313.0  
(22) Date of Filing: 12.10.2016

(51) INT CL:  
B60N 2/30 (2006.01) B60N 2/36 (2006.01)  
B60R 5/04 (2006.01) B60R 13/01 (2006.01)

(71) Applicant(s):  
Ford Global Technologies, LLC  
Suite 800, 330 Town Center Drive,  
Fairlane Plaza South, Dearborn 48126, Michigan,  
United States of America

(56) Documents Cited:  
EP 2957457 A

(58) Field of Search:  
INT CL B60N, B60R  
Other: WPI, EPODOC

(72) Inventor(s):  
James Neugebauer  
Richard Craven  
James Nicholas Murray  
Bruce Southey

(74) Agent and/or Address for Service:  
Haseltine Lake LLP  
5th Floor Lincoln House, 300 High Holborn, LONDON,  
WC1V 7JH, United Kingdom

(54) Title of the Invention: **Vehicle loadspace floor**  
Abstract Title: **Vehicle loadspace floor convertible into a seat**

(57) A vehicle loadspace floor 101 comprising a first deployable portion 103 and a second deployable portion 105, the first and second deployable portions 103, 105 cooperating to form a rearward-facing seat 107 extending through the opening of a trunk of a vehicle when deployed from the loadspace. The 1<sup>st</sup> deployable portion 103 deploys to form a seat back 109 of the seat 107. The 2<sup>nd</sup> deployable portion deploys to form a seat base 111 of the seat 107. The 2<sup>nd</sup> deployable portion may deploy to form a bumper protector. The 1<sup>st</sup> deployable portion 103 may comprise a 1<sup>st</sup> panel 115A of the loadspace floor. The 2<sup>nd</sup> deployable portion may comprise a 2<sup>nd</sup> panel 115B of the loadspace floor. The floor 101 may comprise a 3<sup>rd</sup> deployable portion which provides a 3<sup>rd</sup> panel 115C configured to support the 1<sup>st</sup> deployable portion 103 in a deployed state.

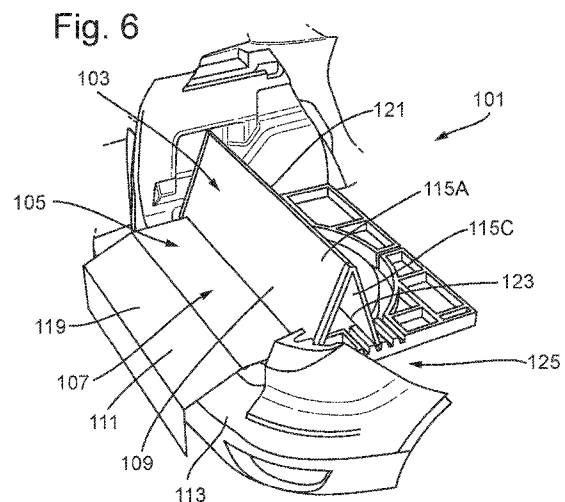
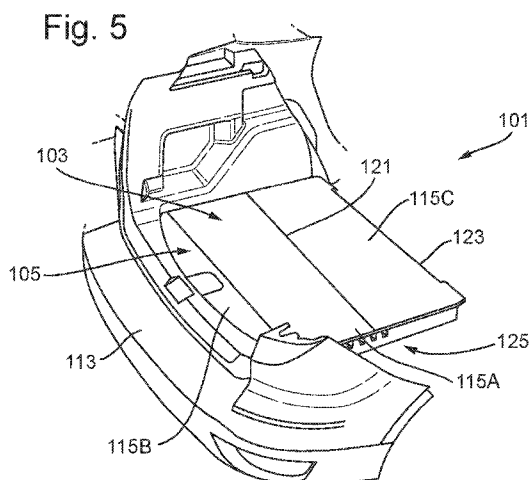

Fig. 1

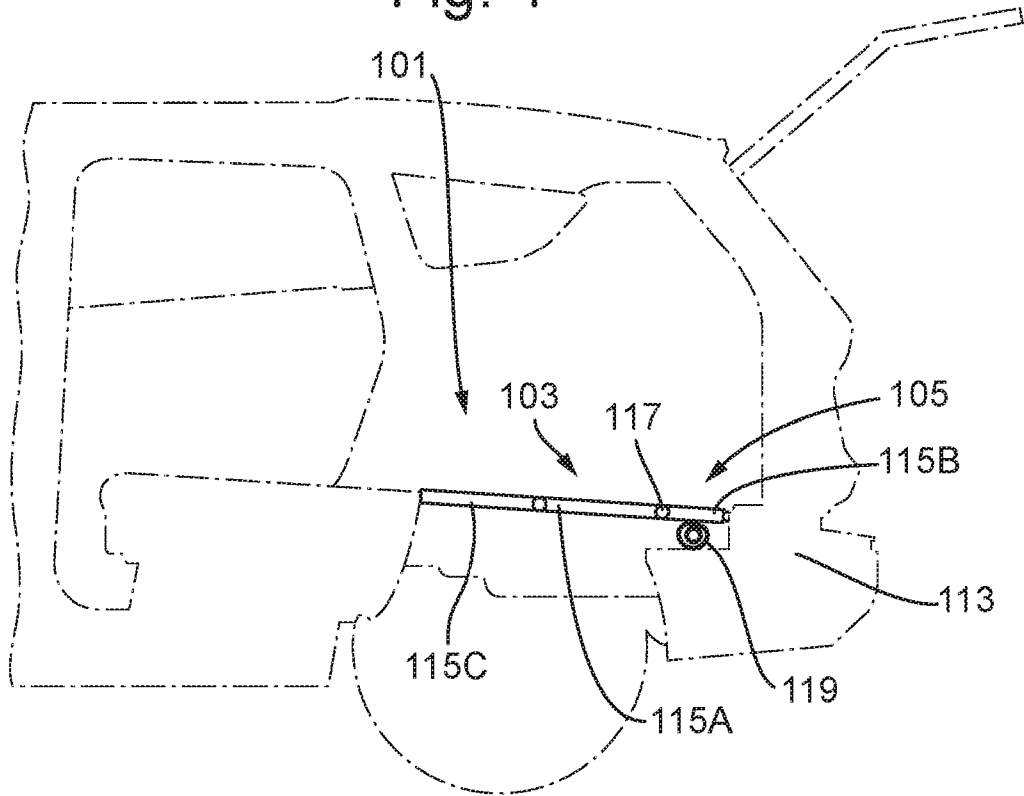

Fig. 2

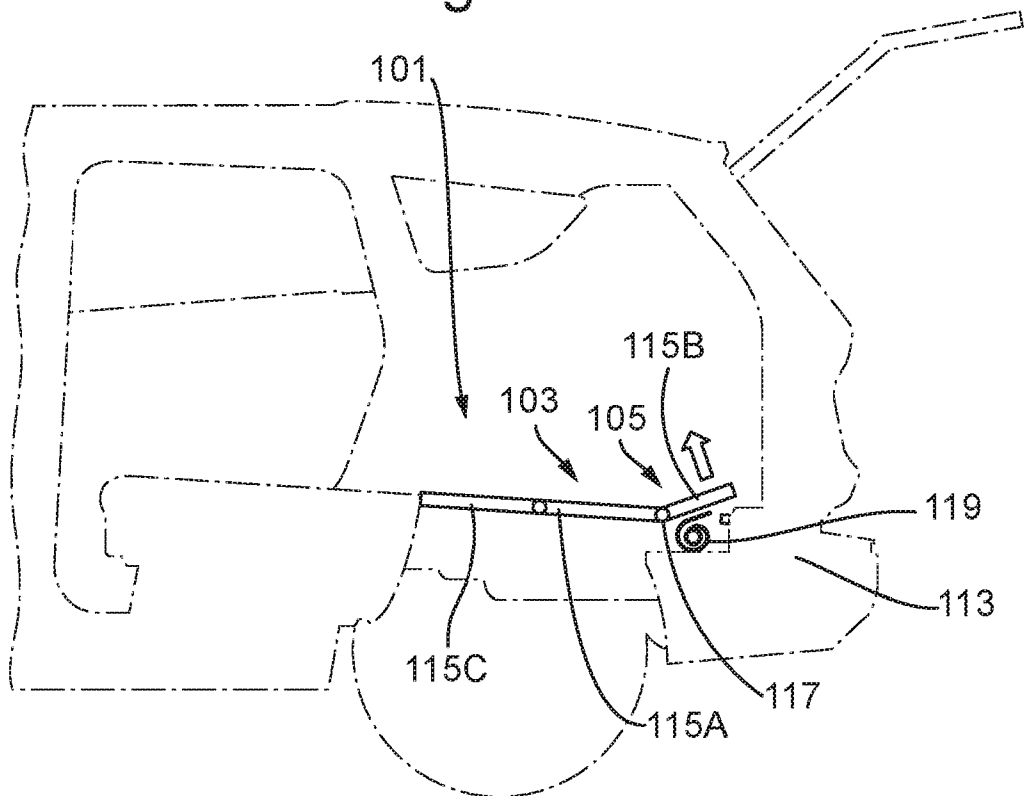

Fig. 3

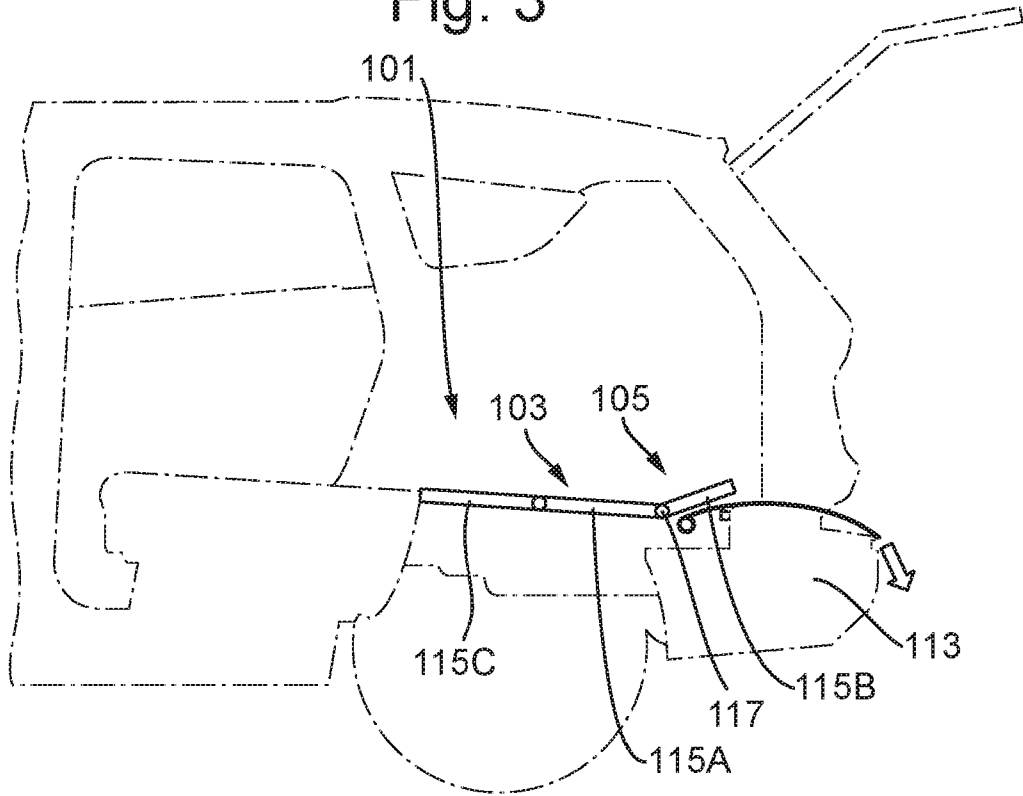

Fig. 4

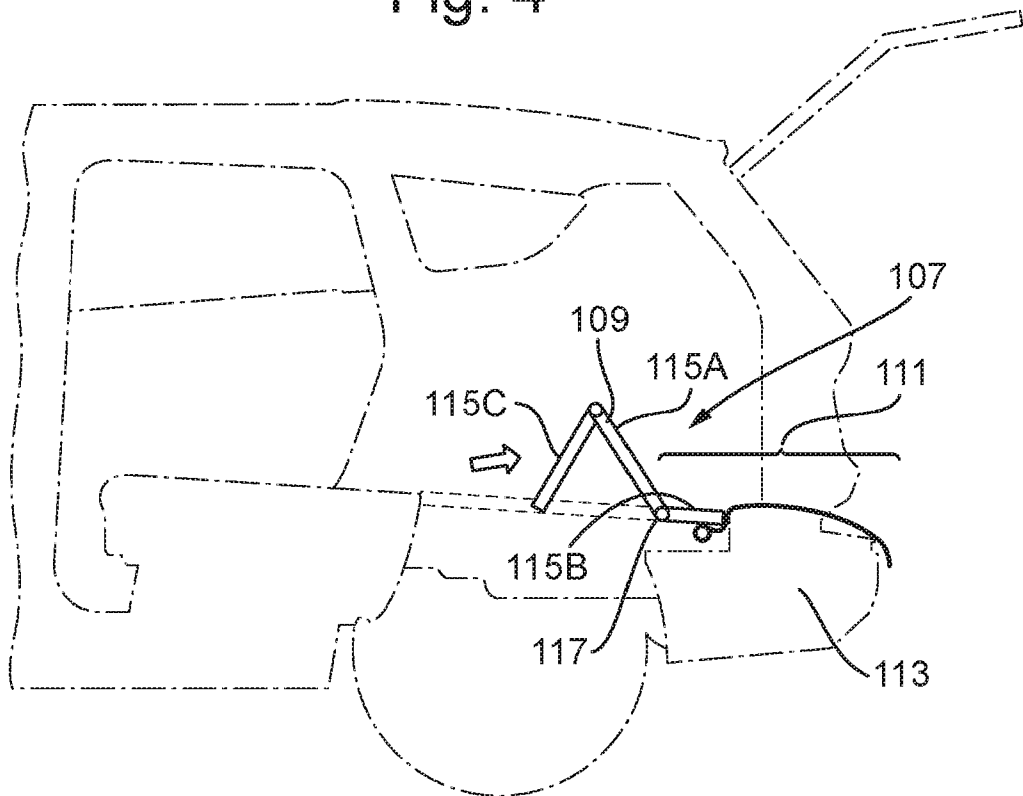

Fig. 5

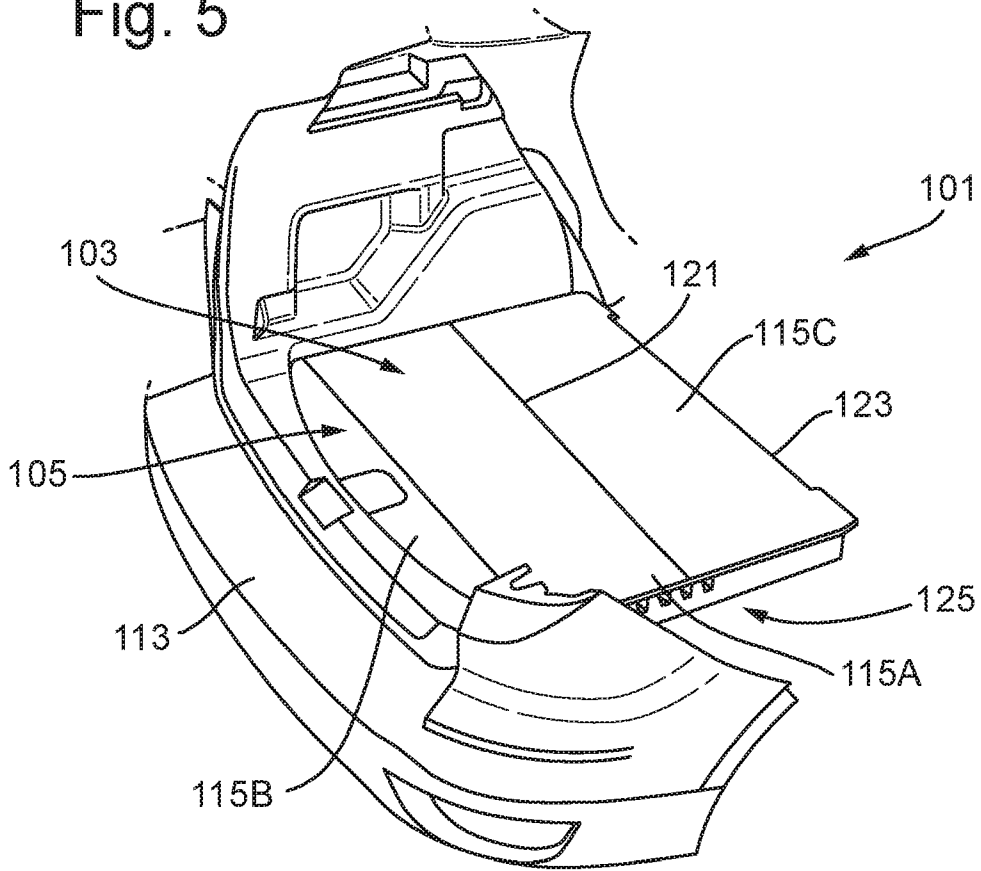
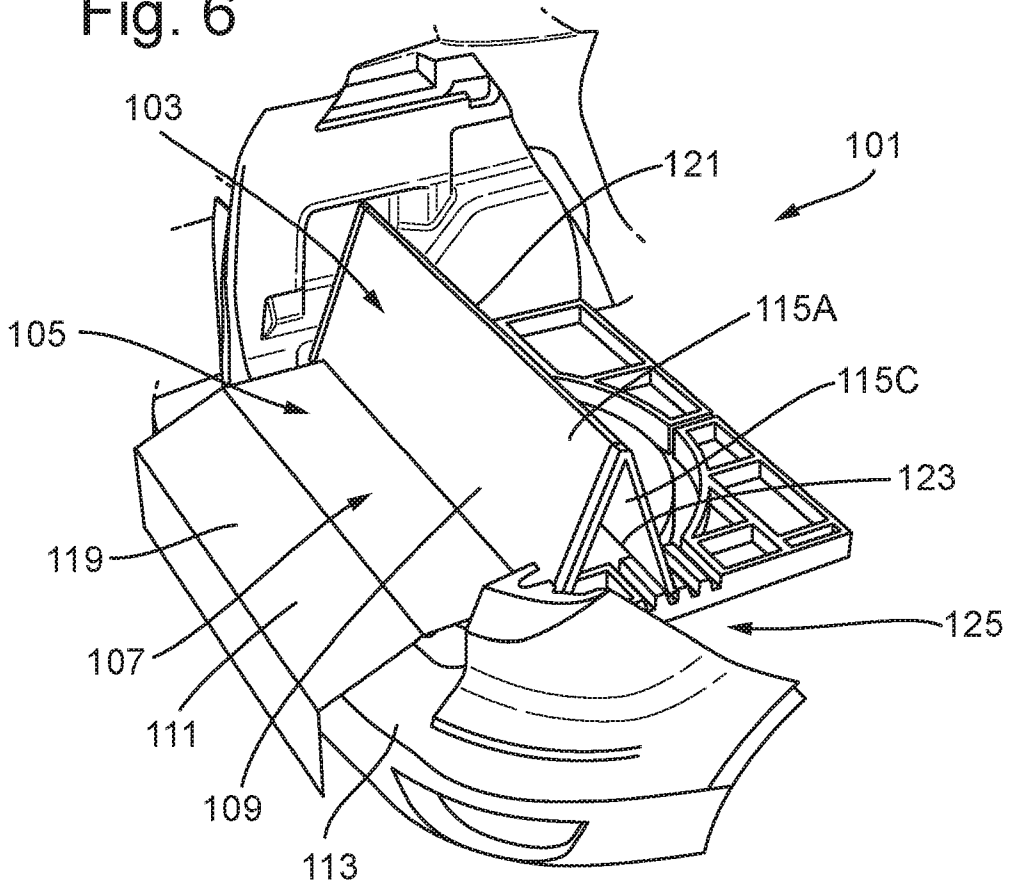

Fig. 6



## Vehicle Loadspace Floor

This disclosure relates to a vehicle loadspace floor, and particularly, but not exclusively, relates to a load space floor that is reconfigurable to form a seat.

5

### Introduction

When a vehicle is parked with its tailgate open, the rear bumper of the vehicle can be used as a seat. For example, it is common for an individual to sit on the rear bumper whilst changing their shoes or whilst watching a spectacle, since the rear bumper is at a convenient height.

10

One problem with using the rear bumper as a seat is that it can be uncomfortable, as the bumper is shaped for functional reasons, such as crash safety, and/or to ensure adequate closing of the tailgate, instead of for the seating of an individual.

15

Another problem is that the rear end of the vehicle can often be dirty, which may deter an individual from sitting on the rear bumper so as to avoid spoiling their clothes. Additionally or alternatively, the individual may wish to prevent the rear bumper from being damaged when they sit on the rear bumper, for example where the individual's clothing may have a zips and/or buckles that could scratch the paint of the rear bumper.

20

Document US20070018475A1 discloses a deployable pad that protects a vehicle rear bumper from accidental damage when cargo is loaded or off-loaded. The deployable pad folds flat onto the cargo area floor, a cargo area liner or the trunk floor when not in use.

25

Document US3902752A discloses a bumper apron unit for automobile trunks to protect an individual's clothes when loading or unloading items. The apron is foldable in an accordion shape and fits in a carrier connected to the trunk wall, to prevent it from taking up space on the trunk floor and from becoming unfolded and getting dirty.

30

It is noted, however, that none of the above documents disclose a bumper protector that is specially adapted to form a seat. It is desirable, therefore, for an individual to be

35

able to sit comfortably over the rear bumper of a vehicle without dirtying their clothes and/or damaging the bumper.

### **Statements of Invention**

5

According to an aspect of the present disclosure there is provided a vehicle loadspace floor comprising a first deployable portion and a second deployable portion, the first and second deployable portions cooperating to form a rearward-facing seat extending through the opening of a trunk of the vehicle when deployed from the loadspace floor.

10

The first deployable portion may deploy to form at least a portion of a seat back of the seat. For example, the first portion may be moveable from a first position in which it forms a usable surface of the loadspace floor to a second position in which it forms a support against which an occupant may lean when using the rearward-facing seat. The support may comprise at least a lower back support. For example, the loadspace floor may be reconfigured to form a lower back support for an occupant, which increases the level of comfort of the rearward-facing seat when an occupant uses the seat, especially over extended periods.

15

20 The second deployable portion may deploy to form at least a portion of a seat base of the seat. For example, the second portion may be moveable from a first position in which it forms a usable surface of the loadspace floor to a second position in which it forms a support on which an occupant may sit when using the rearward-facing seat.

25 The second deployable portion may deploy to form a bumper protector. For example, the bumper protector may be configured to shield an individual's legs from a rear bumper of the vehicle when seated in the rearward-facing seat. Additionally or alternatively, the bumper protector may be configured to protect the paintwork/finish on the exterior surface of the rear bumper. For example, the bumper protector may be positioned to protect the rear bumper against damage from an occupant's shoes when  
30 the second portion is in the second position. The bumper protector may be stowable underneath the loadspace floor. The bumper protector may be biased towards a stowed position underneath the loadspace floor. The bumper protector may comprise at least one flexible portion and/or at least one rigid portion.

35

The present disclosure is advantageous, therefore, as an individual is able to reconfigure the loadspace floor of the vehicle to form a rear-facing seat that extends through the opening to the trunk of the vehicle. In other words, when the seat is in a deployed state, at least one of the first deployable portion and the second deployable  
5 portion extends from within the vehicle to a position outside the vehicle. The rear-facing seat may extend at least partially over a rear bumper of the vehicle. The rear-facing seat may be restricted from moving to a fully deployed state when the opening to the trunk is covered, for example when a trunk door is closed. In one arrangement, the opening of the tailgate may affect the deployment of the rear-facing seat, for example  
10 by virtue of a mechanical connection and/or an electronic control system.

The first deployable portion may comprise a first panel of the loadspace floor. The first panel may be movably, for example slidably and/or rotationally, coupled to the loadspace floor. The first panel may be aligned with the remainder of the loadspace  
15 floor when in a first position, i.e. a stowed position. The first panel may be inclined and/or spaced apart from the remainder of the loadspace floor when in a second position, i.e. a deployed position. An upwardly facing surface of the first panel may define a portion of a usable surface of the loadspace floor when in the first panel is in the first position. The said upwardly facing surface of the first panel may define a  
20 support surface of the seat back when the first panel is in the second position. In other words, the rearward-facing seat may be configured such that the said upwardly facing surface of the first panel is the surface of the seat back against which the occupant leans when seated. The said upwardly facing surface of the first panel may be shaped to engage an occupant's back.

25

The second deployable portion may comprise a second panel of the loadspace floor. The second panel may be movably, for example slidably and/or rotationally, coupled to the loadspace floor. The second panel may be aligned with the remainder of the loadspace floor when in a first position, i.e. a stowed position. The second panel may  
30 be inclined and/or spaced apart from with the remainder of the loadspace floor when in a second position, i.e. a deployed position. An upwardly facing surface of the second panel may define a portion of a usable surface of the loadspace floor when in the second panel is in the first position. The said upwardly facing surface of the second panel may define a support surface of the seat base when the second panel is in the  
35 second position. In other words, the rearward-facing seat may be configured such that

the said upwardly facing surface of the second panel is the surface of the seat base on which the occupant sits when seated. The said upwardly facing surface of the second panel may be shaped to engage an occupant's seat and/or legs.

- 5 The vehicle loadspace floor may comprise a third deployable portion configured to support the first deployable portion in a deployed state. The third deployable portion may be movably coupled to the first deployable portion. The third deployable portion may be configured to engage a locking feature of the loadspace floor, for example a slot. The engagement between the third deployable portion and the locking feature  
10 may set the distance by which the first deployable portion is deployed from the loadspace floor.

The bumper protector may be stowable underneath the loadspace floor. For example, the bumper protector may be stowable underneath the second panel of the loadspace  
15 floor. In this manner, when the second panel is moved from the first position to the second position, the bumper protector may be deployed from underneath the loadspace floor. The bumper protector may be biased towards a stowed position underneath the loadspace floor.

- 20 The vehicle loadspace floor may comprise an operative connection, such as a slidable, rotational and/or geared mechanism, between the first deployable portion and the second deployable portion. The operative connection may be configured to effect the deployment of one of the first deployable portion and the second deployable portion upon the deployment of the other of the first deployable portion and the second  
25 deployable portion. In this manner, an individual may cause both of the first deployable portion and the second deployable portion to be moved to a deployed position, for example a fully deployed position, by moving one of the first deployable portion and the second deployable portion.

- 30 A vehicle may be provided comprising one or more of the above mentioned vehicle loadspace floors.

According to an aspect of the present disclosure there is provided a method of deploying a vehicle seat from a load space floor of a vehicle, the loadspace floor  
35 comprising a first deployable portion and a second deployable portion, the method



comprising: deploying the first and second deployable portions from the loadspace floor, the first and second deployable portions cooperating to form a rearward-facing seat extending through the opening of a trunk of the vehicle.

5 According to an aspect of the present disclosure there is provided a vehicle loadspace floor comprising a first deployable portion and a second deployable portion, the first deployable portion being movable to a position where it forms a seat back of a seat, and the second deployable portion being movable to a position where it forms a support to limit movement of the first deployable portion when in a deployed state.

10

To avoid unnecessary duplication of effort and repetition of text in the specification, certain features are described in relation to only one or several aspects or arrangements of the disclosure. However, it is to be understood that, where it is technically possible, features described in relation to any aspect or arrangement of the disclosure may also be used with any other aspect or arrangement of the disclosure.

15

### **Brief Description of the Drawings**

For a better understanding of the present disclosure, and to show more clearly how it may be carried into effect, reference will now be made, by way of example, to the accompanying drawings, in which:

20

Figure 1 shows a vehicle loadspace floor having a first deployable portion and a second deployable portion;

25

Figure 2 shows the second deployable portion in a deployed state;

Figure 3 shows the second deployable portion in another deployed state;

30

Figure 4 shows the first deployable portion and the second deployable portion in a deployed state

Figure 5 shows the vehicle loadspace floor in a stowed state; and

35

Figure 6 shows the vehicle loadspace floor in a deployed state.

## Detailed Description

The present disclosure provides a loadspace floor 101 of a vehicle, wherein the loadspace floor 101 can be reconfigured for use as a seat. In particular, the loadspace floor 101 comprises a first portion 103 and a second portion 105 that are deployable from the loadspace floor 101 to form a rear-facing seat 107 that extends through the opening of a trunk of the vehicle. In the context of the present disclosure, the term “loadspace floor” is understood to mean any component, system or assembly that may be installed to a vehicle for the purpose of covering at least a portion of the loadspace of the vehicle. For example, the loadspace floor 101 may comprise one or more panels and/or mats that are configured to extend at least partially across the loadspace of the vehicle and/or through the opening of a trunk of the vehicle. The loadspace floor 101 may comprise one or more guide members, frames and/or trays that may be installed to a vehicle for the purpose of covering at least a portion of the loadspace of the vehicle. In one arrangement, the loadspace floor 101 may comprise one or more panels that are movable relative to a body portion of the loadspace floor 101.

Figure 1 depicts one arrangement of the loadspace floor 101 according to the present disclosure in which the first portion 103 is movable from a first position, for example where it forms part of a deck of the loadspace floor 101, to a second position in which it forms a seat back 109 of the rear-facing seat 107. In a similar manner, the second portion 105 is movable from a first position, for example where it forms part of a deck of the loadspace floor 101, to a second position in which it forms a seat base 111 of the rear-facing seat 107. When the first portion 103 and the second portion 105 are deployed from the loadspace floor 101 they cooperate to form a rear-facing seat 107. In other words, when both of the first portion 103 and the second portion 105 are in respective second positions, they form the rear-facing seat 107 extending through the opening of a trunk of the vehicle. The present disclosure therefore provides a vehicle loadspace floor 101 that can be reconfigured for use as a rear-facing seat 107, which allows an individual to sit comfortably over a rear bumper 113 of the vehicle, for example for an extended period of time. This is advantageous as the rear bumper 113 of a vehicle is not specially adapted for use as a seat, which makes it difficult for an individual to use the rear bumper 113 as a place to rest, for example when changing footwear and/or when viewing an outdoor event.

The first portion 103 may be moveably coupled to the loadspace floor 101. For example, the loadspace floor 101 may comprise a rotational and/or slidable first coupling that allows the first portion 103 to deploy from the loadspace floor 101.

5 Similarly, the second portion 105 may be moveably coupled to the loadspace floor 101. For example, the loadspace floor 101 may comprise rotational and/or slidable second coupling that allows the second portion 105 to deploy from the loadspace floor 101.

10 Each of the first portion 103 and the second portion 105 may be independently coupled to the loadspace floor 101, so that an operator can deploy either of the first portion 103 and the second portion 105, as desired. For example, the operator may wish to only deploy the second portion 105 to form the seat base 111 to allow them to perch on the rear bumper 113, without deploying the seatback 109.

15 Alternatively, the loadspace floor 101 may comprise an operative connection between the first and second couplings. The operative connection may be configured such that deployment of one of the first portion 103 and the second portion 105 effects the deployment of the other of the first portion 103 and the second portion 105. For example, the first portion 103 may comprise a lifting feature, such as a handle or a  
20 strap, which the operator may pull to deploy the first portion 103. The operative connection may comprise a geared mechanism configured to effect the deployment of the second portion 105 as the operator deploys the first portion 103. In this manner, the operator may perform only one operation in order to deploy both of the first and second portions 103, 105 to form the rearward-facing seat 107. It is understood that either, or  
25 both of, the first portion 103 and the second portion 105 may be provided with a lifting feature that permits the operator to deploy the rearward-facing seat 107 using a single motion.

30 Figures 1 to 6 depict one arrangement of the loadspace floor 101 according to the present disclosure. In figure 1, the first and second deployable portions 103, 105 are in a stowed position in the loadspace floor 101, such that the loadspace floor 101 comprises a platform that substantially spans the loadspace of the vehicle. The first and second deployable portions 103, 105 may each comprise one or more panels that are movable to an inclined position, i.e. a position where the panel is not in line with the  
35 remaining portion of the loadspace floor 101. In order to allow the loadspace floor 101

to be reconfigured, each panel may be rotationally coupled to the loadspace floor 101, for example by virtue of a hinged coupling 117, so that they pivot about a common axis. Each of the panels may, however, be coupled to the loadspace floor 101 in any appropriate manner, for example in a rotational and/or a slidable manner. In the  
5 arrangements shown in figures 1 to 6, the loadspace floor 101 comprises a first panel 115A, a second panel 115B and a third panel 115C, the first and third panel 115A, 115C forming at least part of the first deployable portion 103, and the second panel 115B forming at least part of the second deployable portion 105. It is understood, however, that the first and second deployable portions 103, 105 may comprise any  
10 appropriate number and/or type of components that allow the loadspace floor 101 to be reconfigured to form the rear-facing seat 107, and each of the first and second deployable portions 103, 105 are not limited to comprising the components shown in the appended figures. Indeed, the loadspace floor 101 may comprise one or more further deployable portions, each comprising any appropriate number and/or type of  
15 components that allow the loadspace floor 101 to be reconfigured to form the rear-facing seat 107.

In figure 2, the second deployable portion 105 has been moved from the stowed position to the deployed position, so that the panel 115B of the second portion 105 is  
20 inclined to the remaining portion of the loadspace floor 101. Movement of the panel 115B of the second portion 105 results in the second portion 105 forming at least part of the seat base 111 of the rear-facing seat 107. For example, the panel 115B of the second portion 105 may be configured to adjoin a portion of the rear bumper 113, so that the panel 115B of the second portion 105 forms the seat base 111 in combination  
25 with a portion of the rear bumper 113. Although it is not shown in figures 2 to 4, it is understood that in another arrangement the panel 115B of the second portion 105 may extend through the opening of the trunk of the vehicle when in the deployed position. In a similar manner, the panel 115A of the first portion 103 may extend through the opening of the trunk of the vehicle when in the deployed position.

30

In one arrangement, the first portion 103 may comprise a locking feature configured to lock the first portion 103 in the deployed position. For example, the first portion 103 may comprise a locking feature configured to engage a portion of the body of the vehicle, so as secure the first portion 103 in the deployed position. In this manner, the  
35 first portion 103 is securable in the deployed state so as to limit movement of the first

portion 103 under the weight of an occupant of the rear-facing seat 107. In figures 4 and 6, the locking feature comprises the third panel 115C, which is configured to support the first panel 115A when the first panel 115A is deployed from the loadspace floor 101. The first and third panels 115A, 115C may be movably coupled to each other, so that as an individual deploys the first portion 103 from the loadspace floor 101, the first and third panels 115A, 115C articulate relative to each other to be brought into respective positions that allows the third panel 115C to support the first panel 115A.

10 Additionally or alternatively, the second portion 105 may comprise a locking feature configured to engage a portion of the body of the vehicle, such as the rear bumper 113, so as to lock the second portion 105 in the deployed position. In this manner, the second portion 105 is securable in the deployed state so as to restrain movement of the second portion under the weight of an occupant of the rear-facing seat 107.

15

In the arrangement shown in figures 1 to 6, the second deployable portion 105 comprises a bumper protector 119 that is deployable from the loadspace floor 101. The bumper protector 119 may be provided in combination with the second panel 115B of the second portion 105 so that the panel 115B and the bumper protector 119 form the seat base 111 when the second portion 105 is in the deployed state. It is appreciated, however, that the second deployable portion 105 may comprise only the bumper protector 119, and that the second panel 115B may be provided as an additional component of the loadspace floor 101.

25 In the appended figures, the bumper protector 119 is secured to the underside of the panel 115B so that the bumper protector 119 may be deployed upon lifting the panel 115B up from the loadspace floor 101. In particular, figure 3 depicts the bumper protector 119 being deployed from the underside of the panel 115B to a position where the bumper protector 119 shields an occupant's legs from the rear bumper 113 (and/or the rear bumper 113 from the occupant's legs) when seated in the rear-facing seat 107. In this manner, the occupant may use the rear-facing seat 107 without concern of soiling their clothes on the rear bumper 113 (or damaging the rear bumper 113).

35 In the illustrated embodiment, the second portion 105 of the rear-facing seat 107 may comprise the panel 115B and the bumper protector 119 which cooperate to form the

seat base 111 of the rear-facing seat 107. However, in one or more other arrangements, which are not shown, the bumper protector 119 may be provided at any appropriate location on the vehicle. For example, the bumper protector 119 need not necessarily be physically coupled to the panel 115B, and may be stowed at a position remote from the second panel 115B. Further, it is understood that the second portion 105 may comprise the bumper protector 119 without the panel 115B. For example, the first deployable portion 103 may comprise the panel 115A and the second portion, may comprise the bumper protector 119, so that when the panel 115A and the bumper protector 119 are deployed from the loadspace floor 101 they cooperate to form the rear-facing seat 107.

In figures 4 and 6, the first deployable portion 103 has been moved from the stowed position to the deployed position, so that the panel 115A of the first portion 103 is inclined to the remaining portion of the loadspace floor 101. In the arrangement shown in figure 4, the panel 115A of the first portion 103 and the panel 115B of the second portion 105 are positioned at approximately 110 degrees to each other. However, the panel 115A of the first portion 103 and the panel 115B of the second portion 105 may be positioned at any appropriate angle relative to each other.

Movement of the panel 115A of the first portion 103 results in the first portion 103 forming at least part of the seat back 109 of the rear-facing seat 107. For example, the panel 115B of the second portion 105 may be moveable to adjoin the panel 115A of the second portion 105, so that the panel 115A, 115B cooperate to form the rear-facing seat 107, as shown in figure 4. In another arrangement, the first and second portions 103, 105 may be separated, when in a deployed position. For example, where the first and second panels 115A, 115B are independently coupled to the loadspace floor 101, the first and second panels 115A, 115B may be deployed so that there is a gap between the first and second panels 115A, 115B when they form the rear-facing seat 107.

30

In another arrangement (not shown), the panel 115B and the bumper protector 119 may be operatively connected so that deployment of the panel 115B from the loadspace floor 101 causes the bumper protector 119 to be deployed as well. In this manner, the panel 115B may form a cover over the bumper protector 119 when the bumper protector 119 is in a stowed position. Additionally or alternatively, the panel

35

115B may be used as a handle to deploy the bumper protector 119 from the loadspace floor 101.

In one arrangement, the panel 115B may be operatively coupled to the loadspace floor 101 without forming part of the second deployable portion 105. For example, the panel 115B may simply form a cover over the second deployable portion 105, such that the cover may be temporarily moved, e.g. removed, to allow access to the second deployable portion 105.

10 Figures 5 and 6 show perspective views of an arrangement of the loadspace floor 101 in a stowed configuration and a deployed configuration respectively. In the arrangement shown in figure 5, the first deployable portion 103 comprises the first panel 115B and the third panel 115C, and the second deployable portion 105 comprises the second panel 115B and the bumper protector 119. When the loadspace floor 101 is in the stowed configuration, the first, second and third panels 115A, 115B, 115C cooperate to form a platform of the loadspace floor 101 onto which cargo may be loaded. Whilst it cannot be seen from figure 5, the bumper protector 119 is stowed under the second panel 115B, for example in a manner similar to that shown in figures 1 to 4.

20

In figure 6, the first deployable portion 103 and the second deployable portion 105 have been deployed from the loadspace floor 101 to form the rear-facing seat 107, in which the first and third panels 115A, 115C cooperate to form the seat back 109, and the bumper protector 119 forms at least a portion of the seat base 111. In the arrangements shown, the third panel 115C is hingedly coupled to the first panel 115A along what forms a top edge 121 of the seat back 109, when the first portion 103 is in the deployed state. It is appreciated, however, that the third panel 115C may be coupled to the first panel 115A in any appropriate manner, or indeed provided as a separate component. The third panel 115C, for example a lower edge 123 of the third panel 115C, may be configured to engage a locking feature 125, for example a slot, of the loadspace floor 101. Thus, by virtue of the third panel 115C being coupled to the first panel 115A, and the engagement of the third panel 115C with the locking feature 125, the first deployable portion 105 is supported in a position in which it provides the seatback 109 of the rear-facing seat 107. Advantageously, the locking feature 125 may

25  
30

be provided with a plurality of slots that allow the third panel 115C to support the first panel 115A in different positions.

5 It will be appreciated by those skilled in the art that although the disclosure has been described by way of example with reference to one or more arrangements, it is not limited to the disclosed arrangements and that alternative arrangements could be constructed without departing from the scope of the disclosure as defined by the appended claims.



**Claims**

1. A vehicle loadspace floor comprising a first deployable portion and a second deployable portion, the first and second deployable portions cooperating to form a rearward-facing seat extending through the opening of a trunk of the vehicle when deployed from the loadspace floor.
2. A vehicle loadspace floor according to claim 1, wherein the first deployable portion deploys to form a seat back of the seat.
3. A vehicle loadspace floor according to claim 1 or 2, wherein the second deployable portion deploys to form a seat base of the seat.
4. A vehicle loadspace floor according to any of the preceding claims, wherein second deployable portion deploys to form a bumper protector.
5. A vehicle loadspace floor according to claim 4, wherein bumper protector is configured to shield an individual's legs from a rear bumper of the vehicle when seated in the seat.
6. A vehicle loadspace floor according to any of the preceding claims, wherein the first deployable portion comprises a first panel of the loadspace floor.
7. A vehicle loadspace floor according to claim 6, wherein the first panel is movably coupled to the loadspace floor.
8. A vehicle loadspace floor according to any of the preceding claims, wherein the second deployable portion comprises a second panel of the loadspace floor.
9. A vehicle loadspace floor according to claim 8, wherein the second panel is movably coupled to the loadspace floor.
10. A vehicle loadspace floor according to claim 8 or 9, wherein the second panel is inclined to the loadspace floor in a deployed configuration.
11. A vehicle loadspace floor according to any of the preceding claims, wherein the vehicle loadspace floor comprises an operative connection between the first

deployable portion and the second deployable portion, the operative connection being configured to effect the deployment of one of the first deployable portion and the second deployable portion upon the deployment of the other of the first deployable portion and the second deployable portion.

5

12. A vehicle loadspace floor system according to any of the preceding claims, wherein the vehicle loadspace floor comprises a third deployable portion configured to support the first deployable portion in a deployed state.

10

13. A vehicle loadspace floor system according to claim 12, wherein the third deployable portion is movably coupled to the first deployable portion.

15

14. A vehicle loadspace floor system according to claim 12 or 13, wherein the third deployable portion is configured to engage a locking feature of the loadspace floor, the engagement between the third deployable portion and the locking feature setting the distance by which the first deployable portion is deployed from the loadspace floor.

20

15. A vehicle comprising the vehicle loadspace floor of claims 1 to 14.

25

16. A method of deploying a vehicle seat from a load space floor of a vehicle, the loadspace floor comprising a first deployable portion and a second deployable portion, the method comprising:

deploying the first and second deployable portions from the loadspace floor, the first and second deployable portions cooperating to form a rearward-facing seat extending through the opening of a trunk of the vehicle.

30

17. A vehicle loadspace floor as described herein, with reference to, and as shown in the accompanying drawings.

**Claims**

- 5
- 10
- 15
- 20
- 25
- 30
- 35
1. A vehicle loadspace floor system comprising a first deployable portion and a second deployable portion, the first and second deployable portions cooperating to form a rearward-facing seat that extends through the opening of a trunk of a vehicle when the vehicle loadspace floor system is installed to the vehicle and the first and second deployable portions are in a deployed state, wherein the second deployable portion deploys to form a bumper protector.
  2. A vehicle loadspace floor system according to claim 1, wherein the first deployable portion deploys to form a seat back of the seat.
  3. A vehicle loadspace floor system according to claim 1 or 2, wherein the second deployable portion deploys to form a seat base of the seat.
  4. A vehicle loadspace floor system according to any of the preceding claims, wherein bumper protector is configured to shield an individual's legs from a rear bumper of the vehicle when seated in the seat.
  5. A vehicle loadspace floor system according to any of the preceding claims, wherein the first deployable portion comprises a first panel.
  6. A vehicle loadspace floor system according to claim 5, wherein the first panel is movably coupled to the loadspace floor system.
  7. A vehicle loadspace floor system according to any of the preceding claims, wherein the second deployable portion comprises a second panel of the loadspace floor system.
  8. A vehicle loadspace floor system according to claim 7, wherein the second panel is movably coupled to the loadspace floor system.
  9. A vehicle loadspace floor system according to claim 7 or 8, wherein the second panel is inclined to the loadspace floor system in a deployed configuration.
  10. A vehicle loadspace floor system according to any of the preceding claims, wherein the vehicle loadspace floor system comprises an operative connection

26 09 17

between the first deployable portion and the second deployable portion, the operative connection being configured to effect the deployment of one of the first deployable portion and the second deployable portion upon the deployment of the other of the first deployable portion and the second deployable portion.

5

11. A vehicle loadspace floor system according to any of the preceding claims, wherein the vehicle loadspace floor system comprises a third deployable portion configured to support the first deployable portion in a deployed state.

10

12. A vehicle loadspace floor system according to claim 11, wherein the third deployable portion is movably coupled to the first deployable portion.

15

13. A vehicle loadspace floor system according to claim 11 or 12, wherein the third deployable portion is configured to engage a locking feature of the loadspace floor system, the engagement between the third deployable portion and the locking feature setting the distance by which the first deployable portion is deployed from the loadspace floor system.

20

14. A vehicle comprising the vehicle loadspace floor system of claims 1 to 13.

25

15. A method of deploying a vehicle seat from a load space floor system of a vehicle, the loadspace floor system comprising a first deployable portion and a second deployable portion, the method comprising:

deploying the first and second deployable portions, the first and second deployable portions cooperating to form a rearward-facing seat extending through the opening of a trunk of the vehicle when the loadspace floor system is installed to the vehicle, wherein the second deployable portion deploys to form a bumper protector.

30



**Application No:** GB1617313.0

**Examiner:** Mr Ben Potts-Johnson

**Claims searched:** 1 to 17

**Date of search:** 30 March 2017

## Patents Act 1977: Search Report under Section 17

### Documents considered to be relevant:

Category	Relevant to claims	Identity of document and passage or figure of particular relevance
X	1-3,6, 7,11,15,1 6	EP 2957457 A (Volvo) abstract, figures 1 to 5, description paragraphs 26 to 30

### Categories:

X	Document indicating lack of novelty or inventive step	A	Document indicating technological background and/or state of the art.
Y	Document indicating lack of inventive step if combined with one or more other documents of same category.	P	Document published on or after the declared priority date but before the filing date of this invention.
&	Member of the same patent family	E	Patent document published on or after, but with priority date earlier than, the filing date of this application.

### Field of Search:

Search of GB, EP, WO & US patent documents classified in the following areas of the UKC<sup>X</sup> :

--

Worldwide search of patent documents classified in the following areas of the IPC

B60N; B60R

The following online and other databases have been used in the preparation of this search report

WPI, EPODOC

### International Classification:

Subclass	Subgroup	Valid From
B60N	0002/30	01/01/2006
B60N	0002/36	01/01/2006
B60R	0005/04	01/01/2006
B60R	0013/01	01/01/2006