



US 20120022431A1

(19) **United States**
(12) **Patent Application Publication**
Krinke

(10) **Pub. No.: US 2012/0022431 A1**
(43) **Pub. Date: Jan. 26, 2012**

(54) **IONTOPHORETIC DRUG DELIVERY PACKAGING**

Publication Classification

(75) Inventor: **Todd A. Krinke**, Buffalo, MN (US)
(73) Assignee: **Travant Pharma Inc.**, Mendota Heights, MN (US)

(51) **Int. Cl.**
A61N 1/30 (2006.01)
B65B 7/28 (2006.01)
B65B 5/04 (2006.01)
(52) **U.S. Cl.** **604/20; 53/396; 156/69**

(21) Appl. No.: **12/597,950**
(22) PCT Filed: **Sep. 3, 2009**
(86) PCT No.: **PCT/US09/04969**
§ 371 (c)(1),
(2), (4) Date: **Oct. 28, 2009**

(57) **ABSTRACT**

The present invention relates generally to iontophoretic drug delivery systems for transdermal delivery of therapeutic agents and, more particularly, to packaging such systems for long shelf life and easy assembly for use. The system package includes an iontophoretic skin worn patch component that accommodates a power source, electronics, electrodes and a drug pack component that carries a therapeutic agent which is contained as a separate sealed component. The packaged system further provides for ease of assembly at the time of use.

Related U.S. Application Data

(60) Provisional application No. 61/094,442, filed on Sep. 5, 2008.

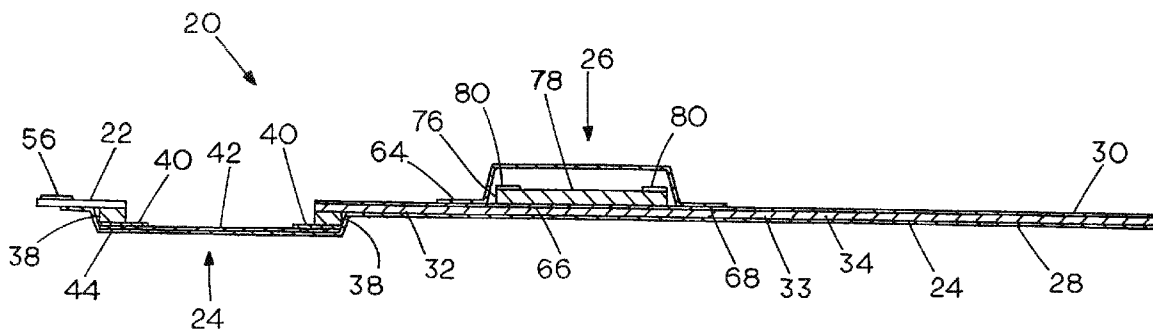

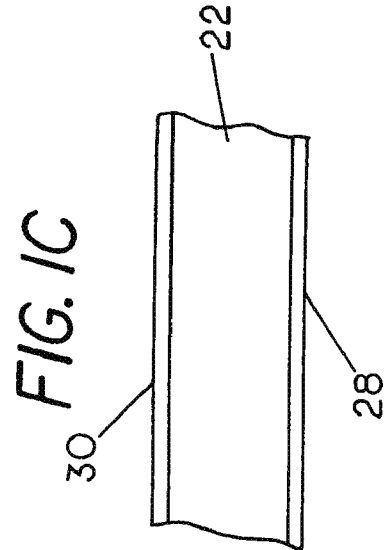
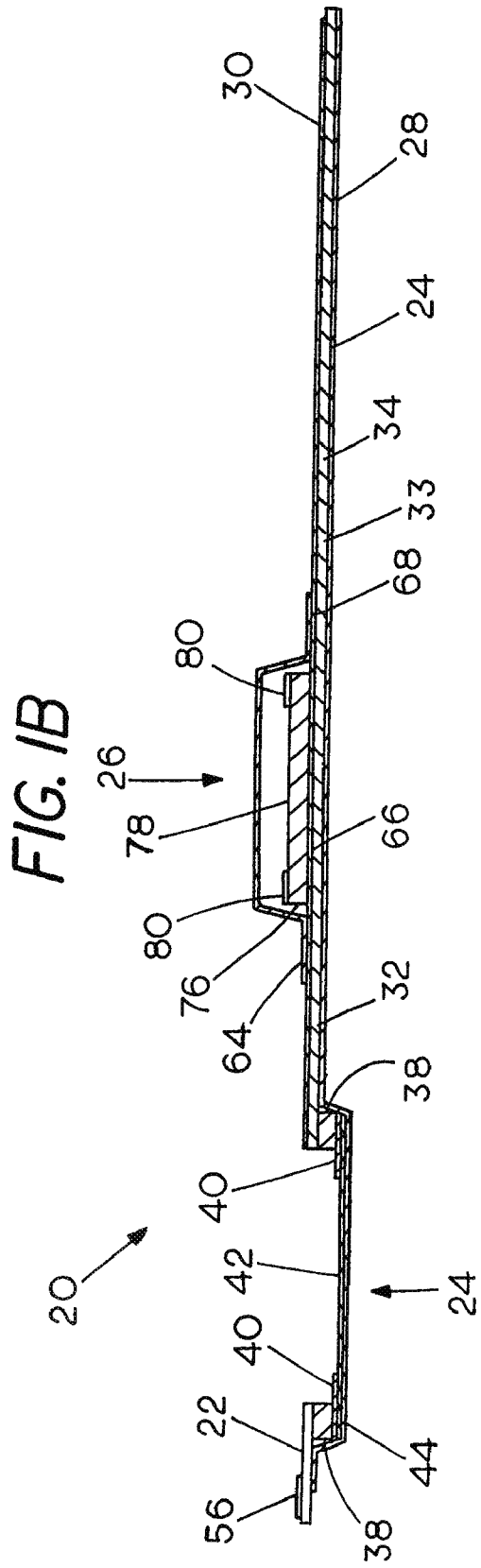
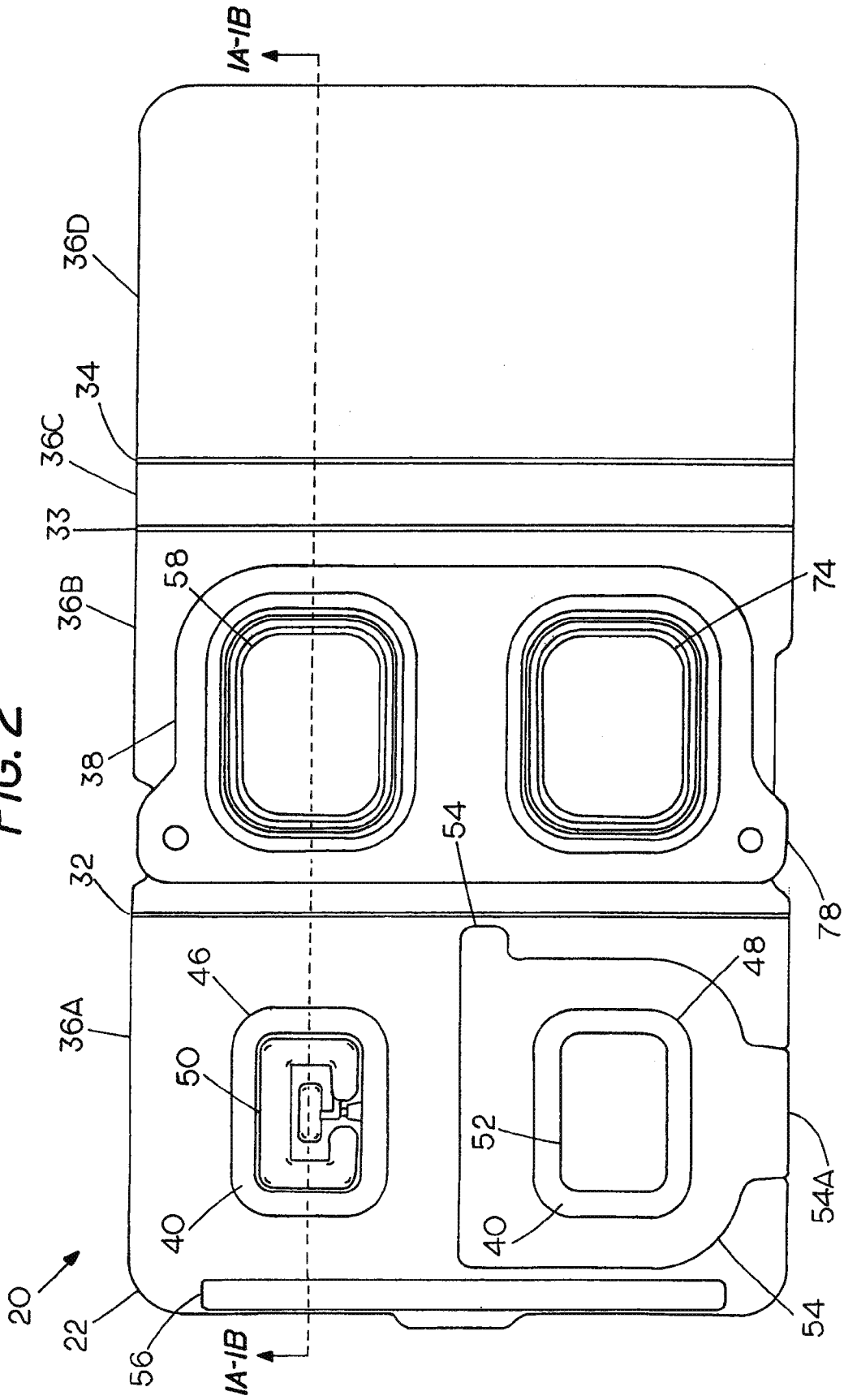

FIG. 2



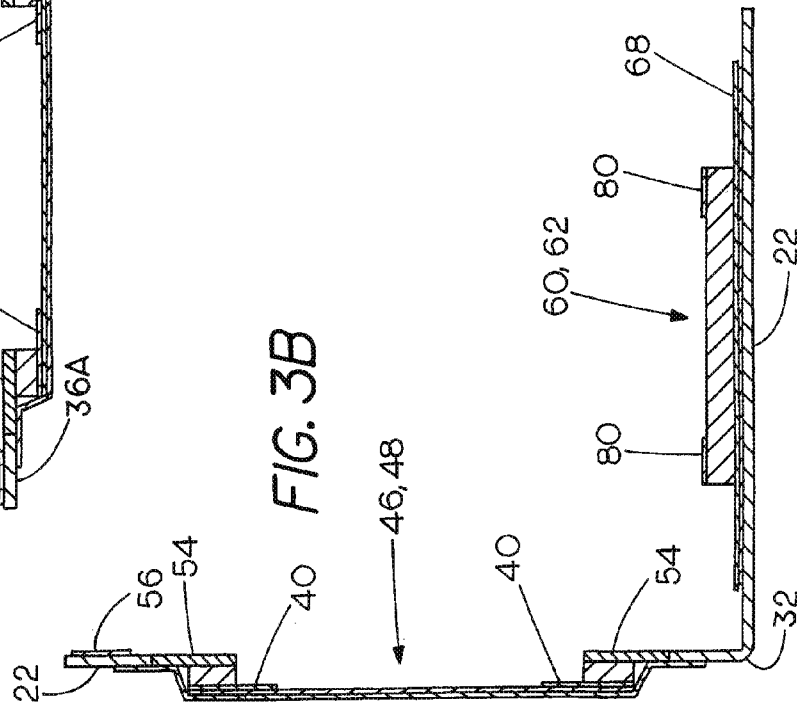
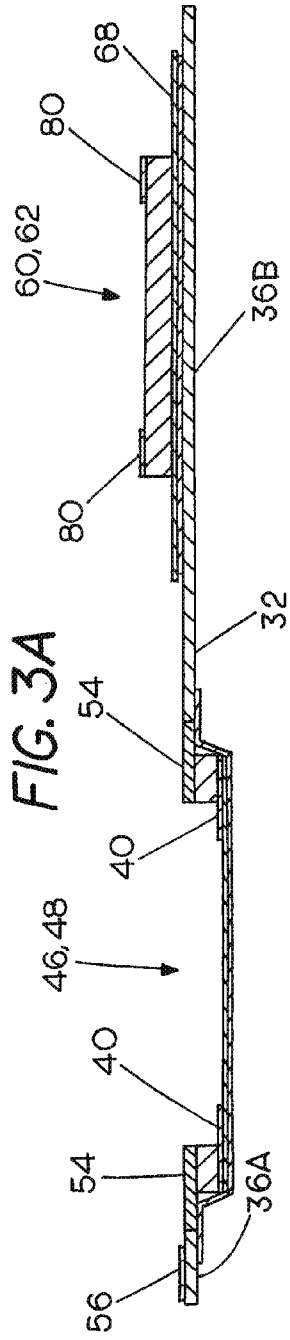

FIG. 3C

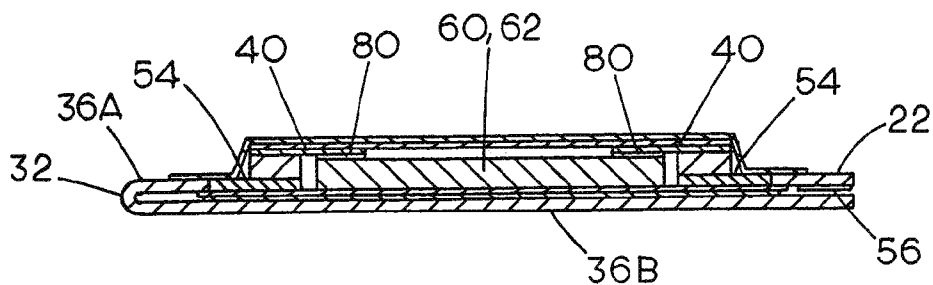
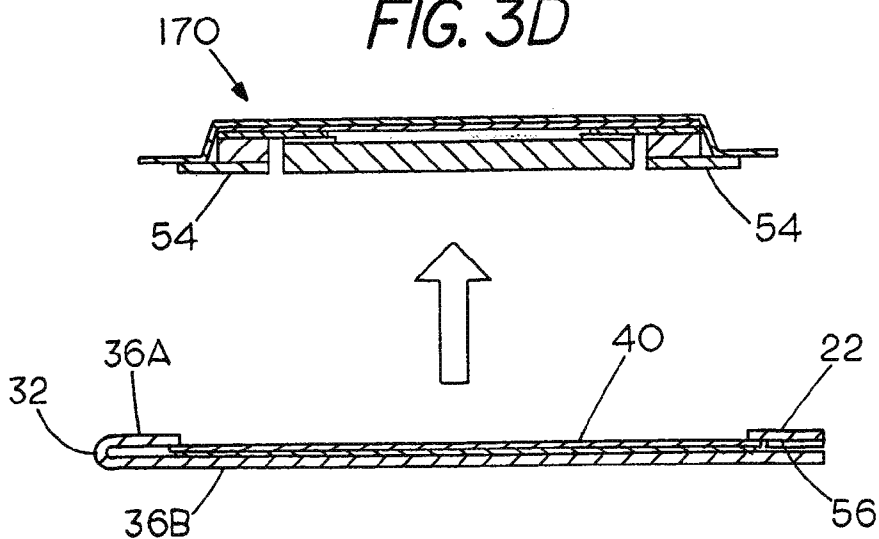
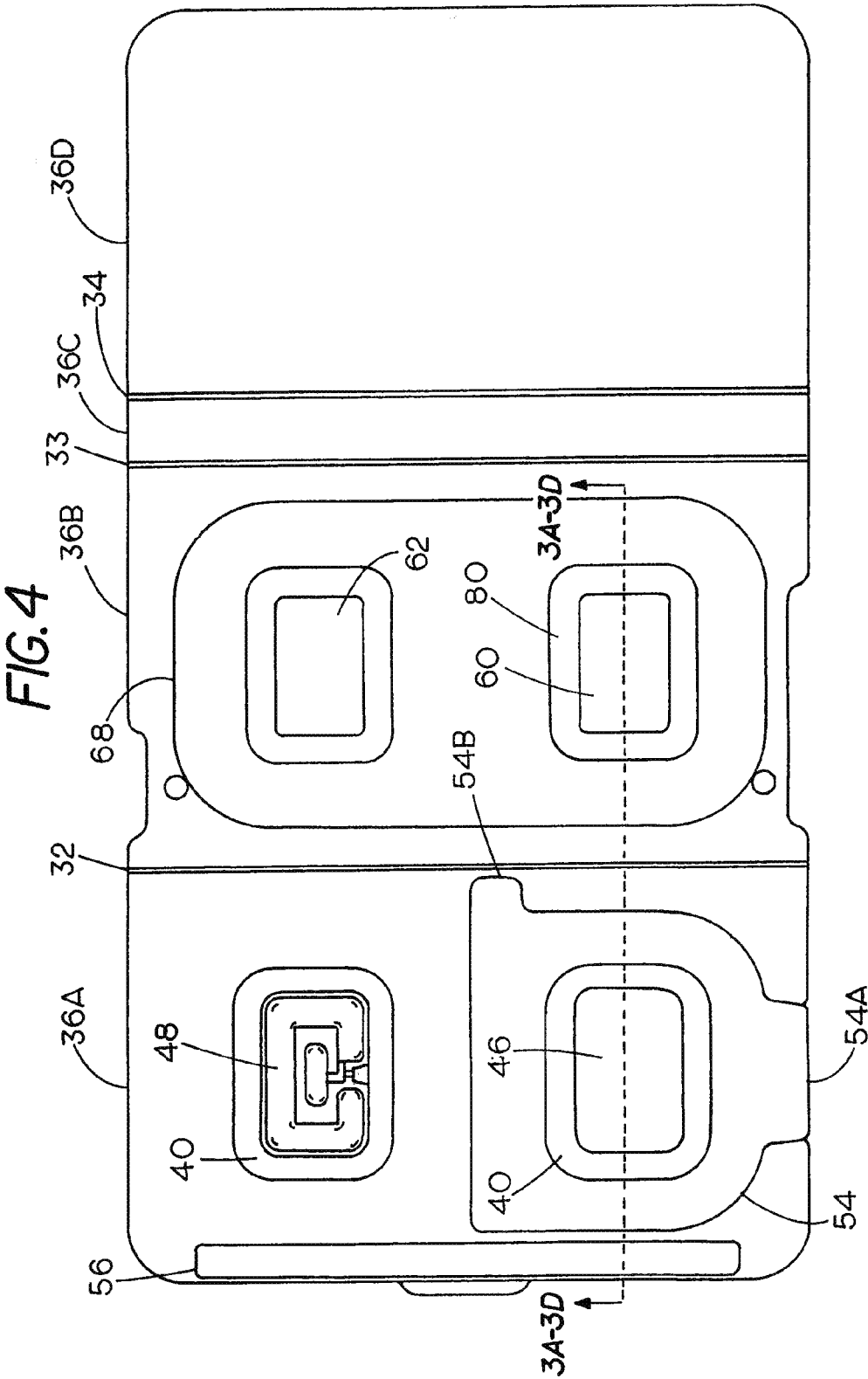
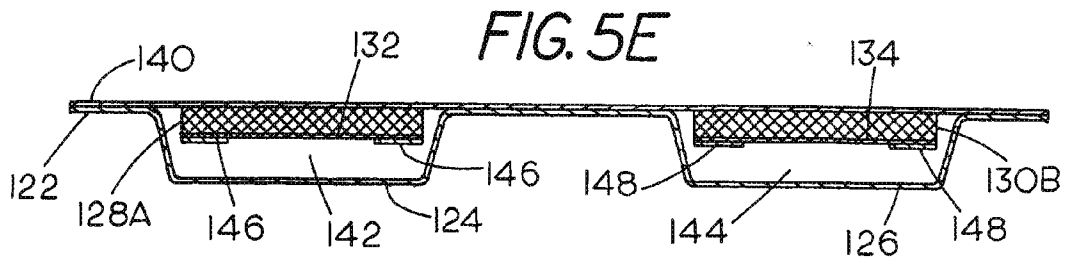
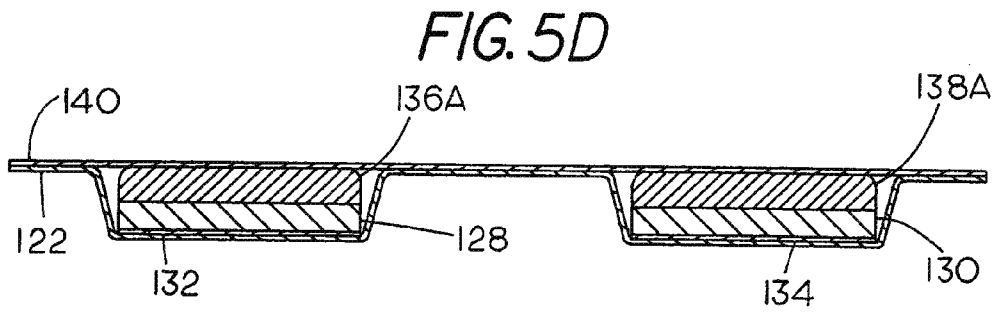
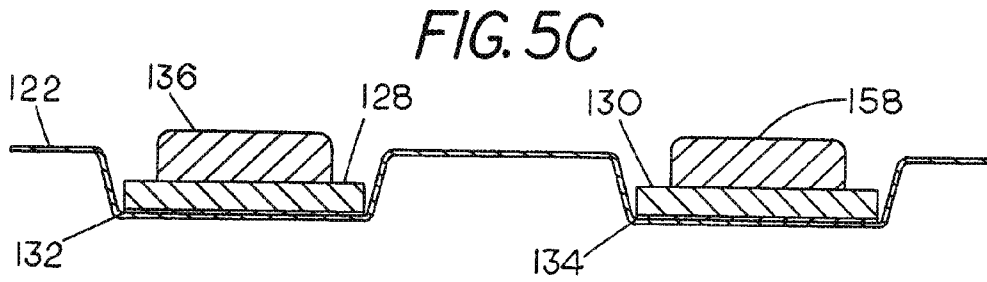
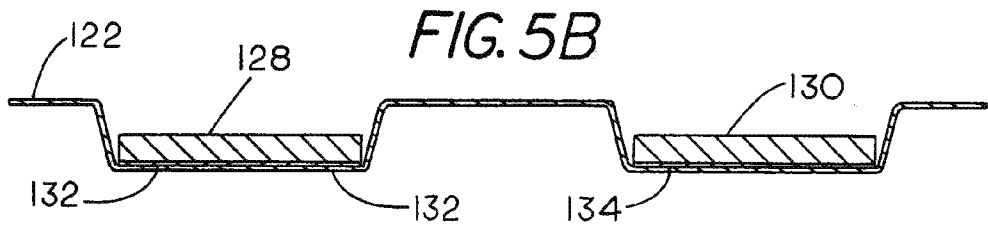
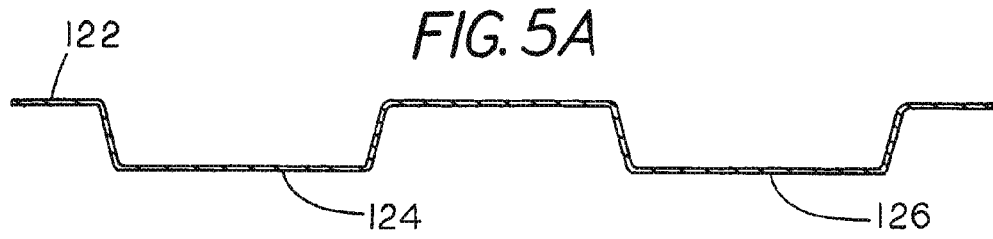
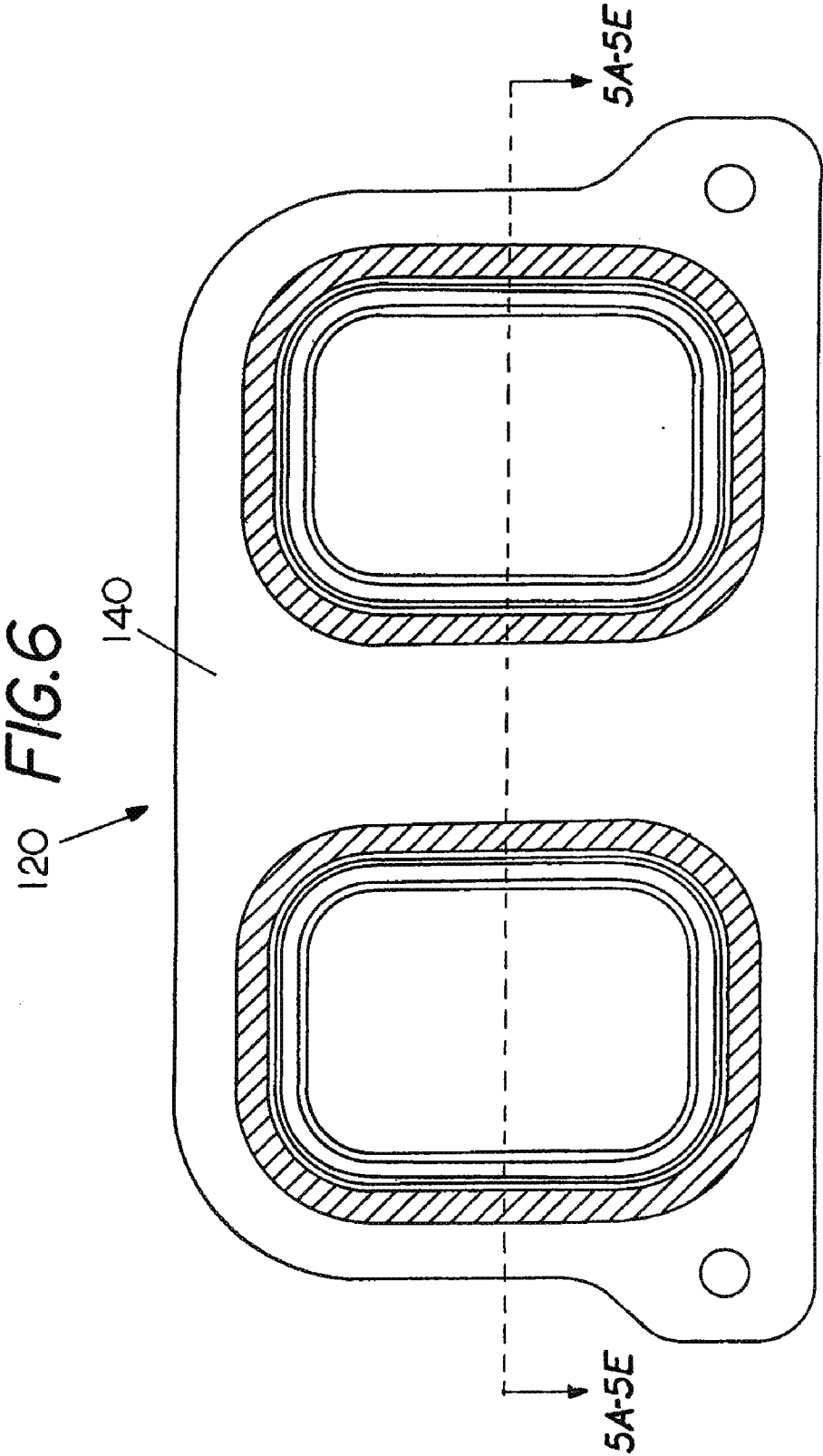

FIG. 3D









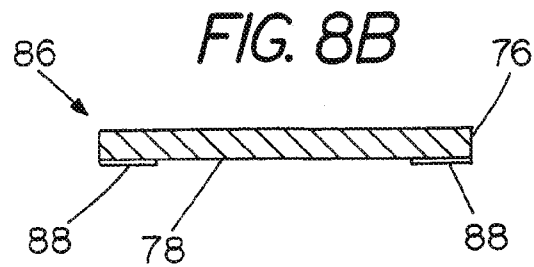
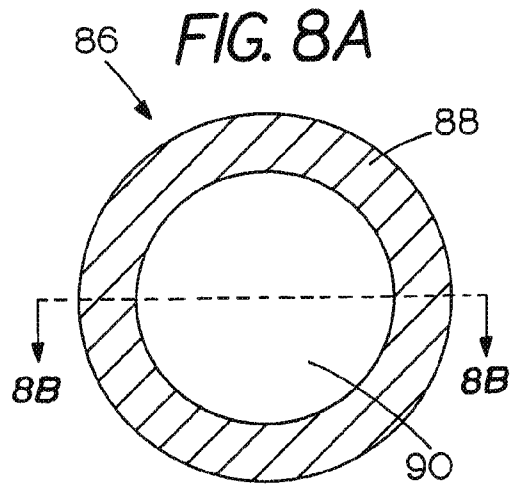
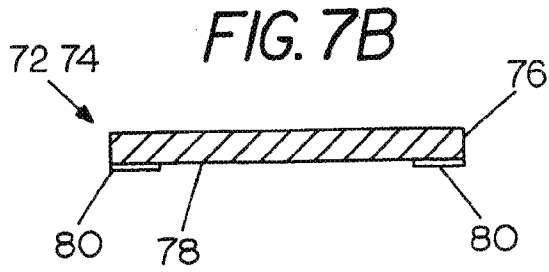
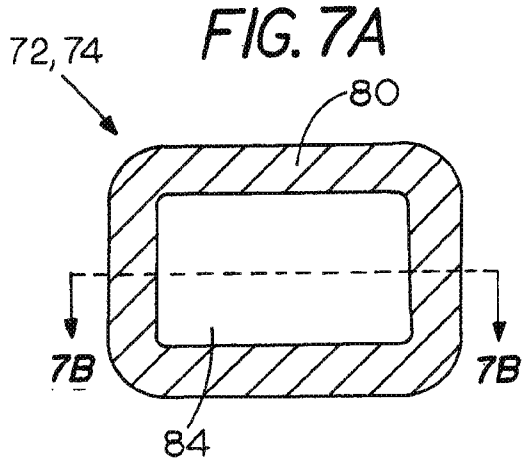
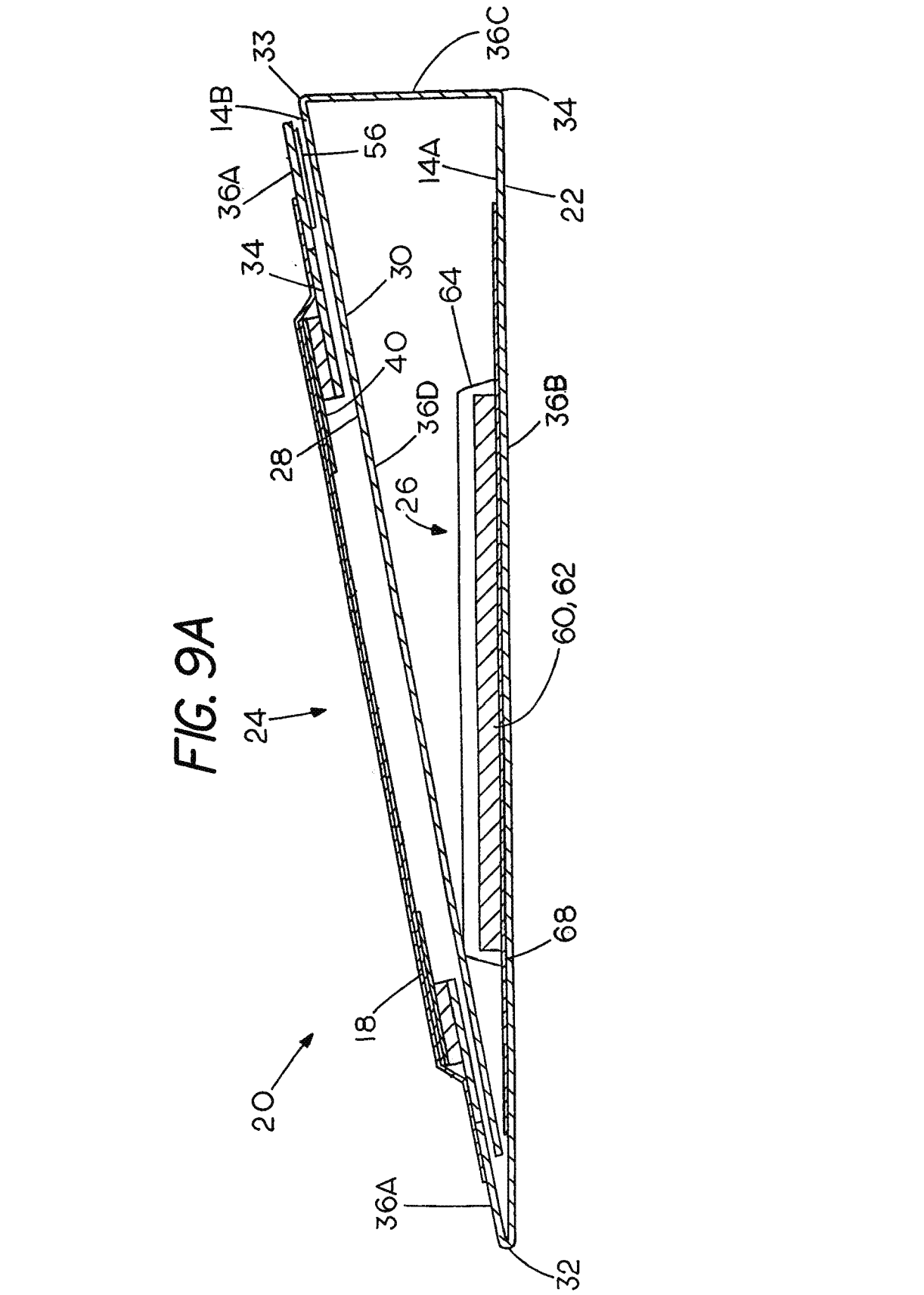

FIG. 9A



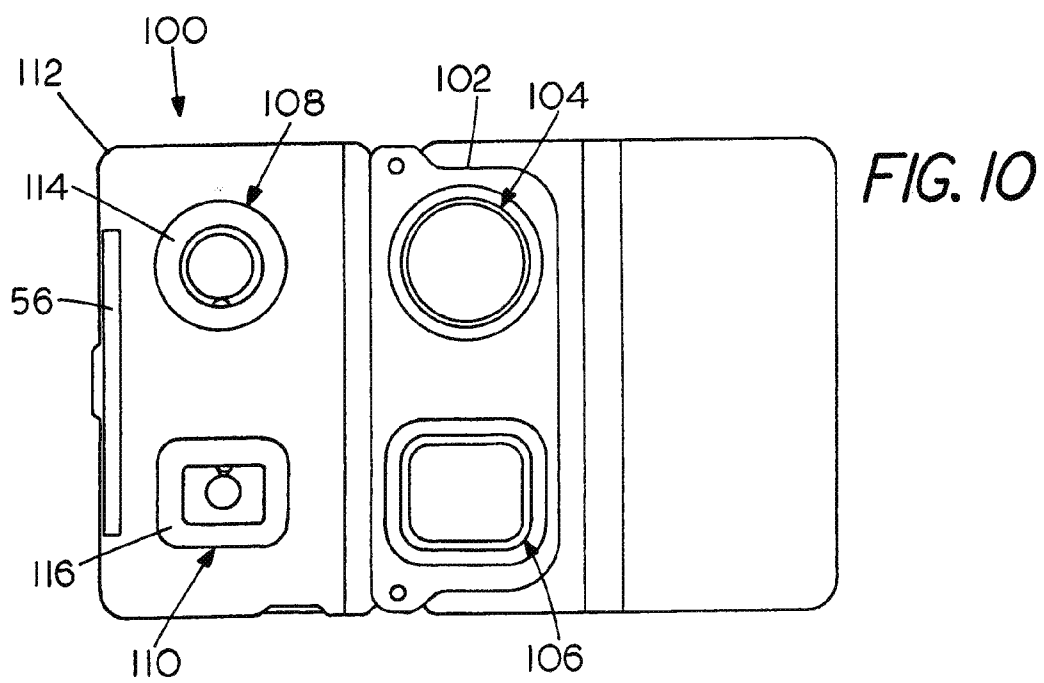
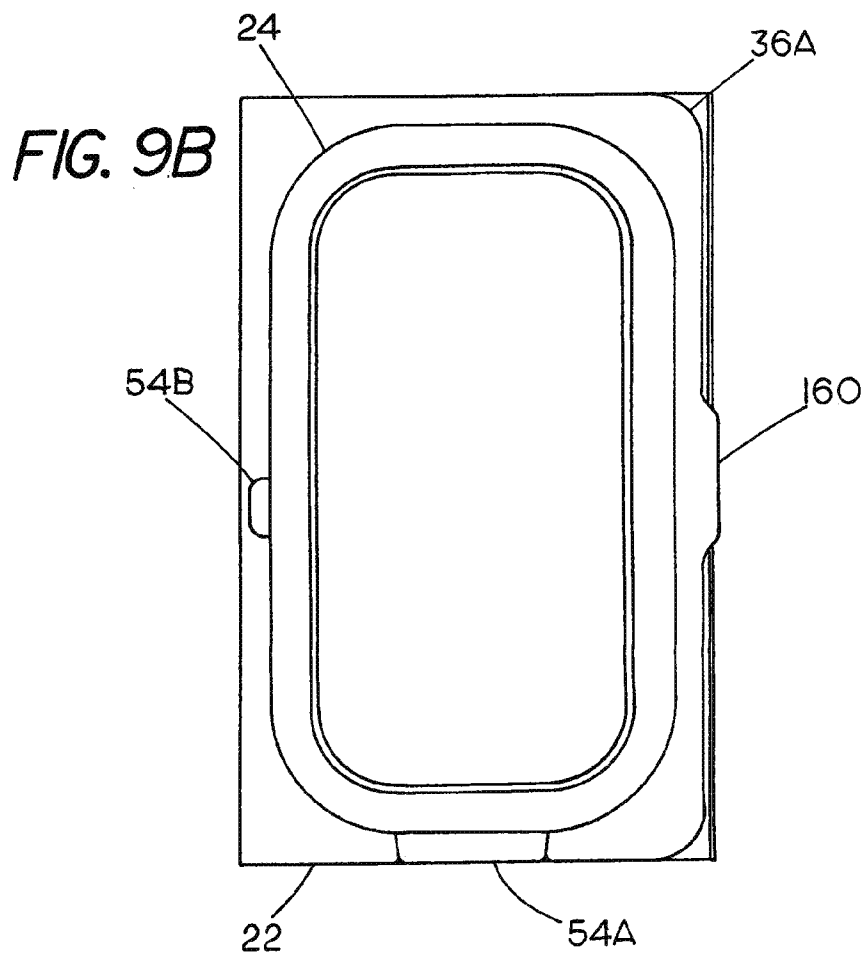

FIG. 11A

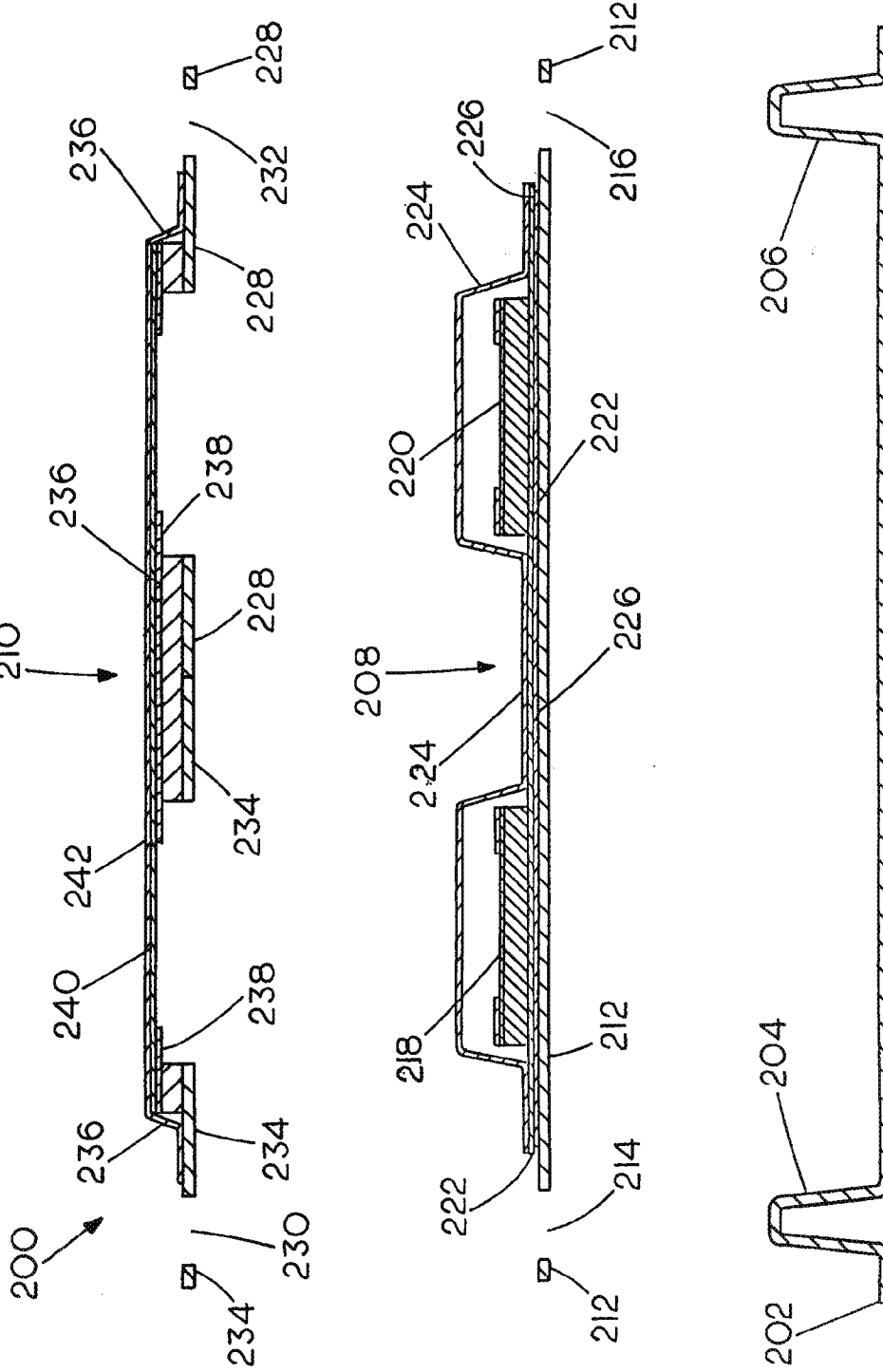
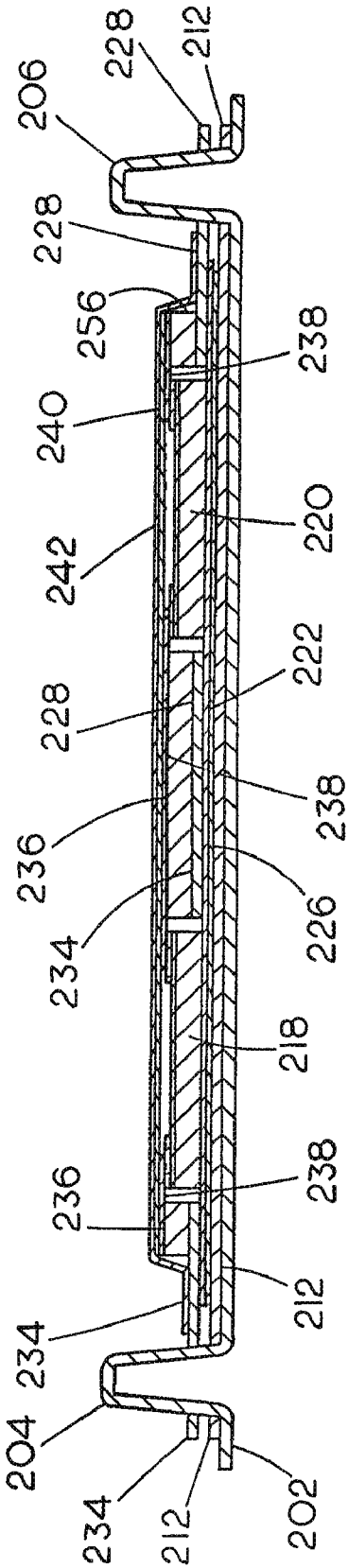

FIG. 11B



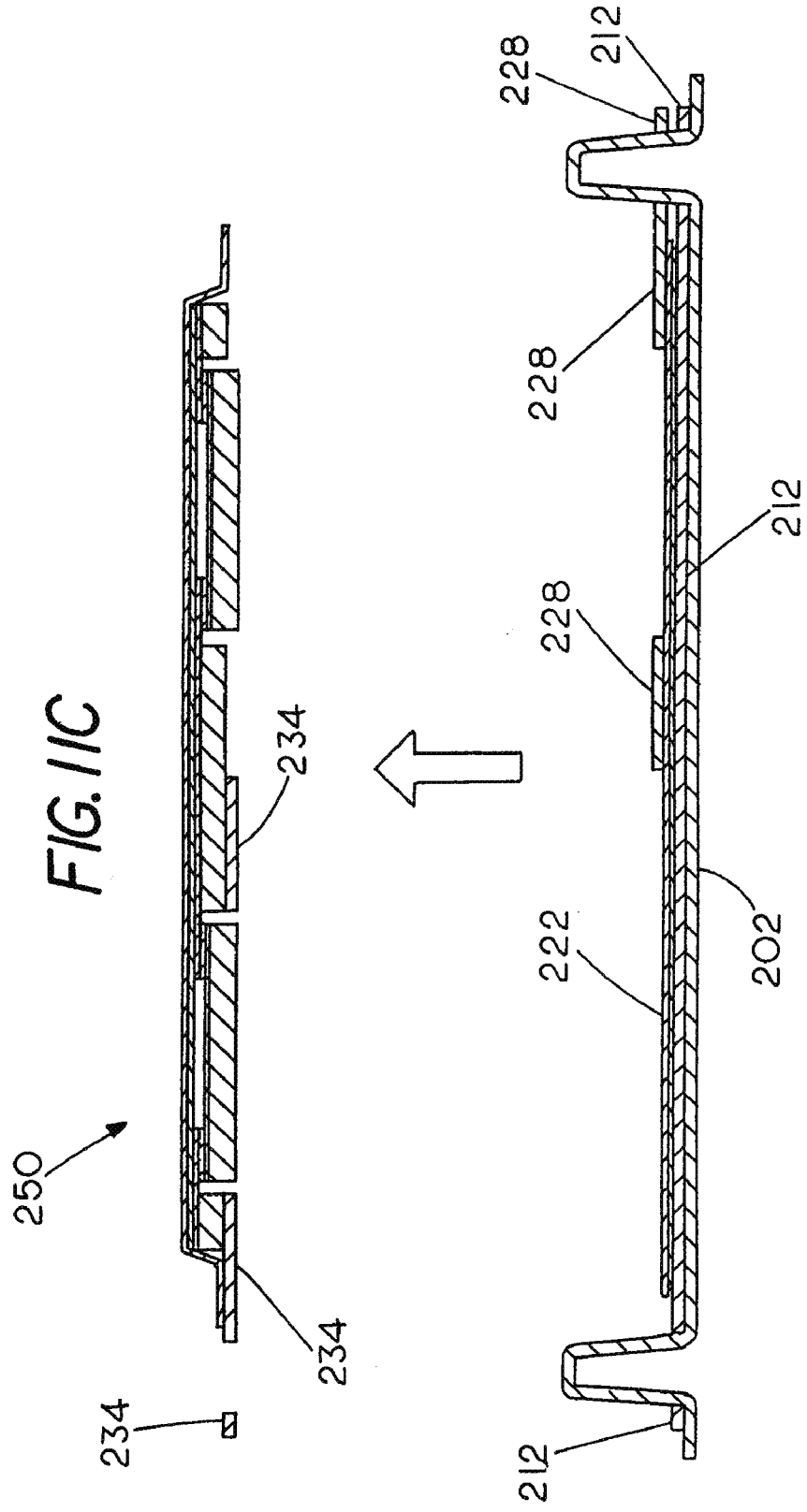

FIG. 12

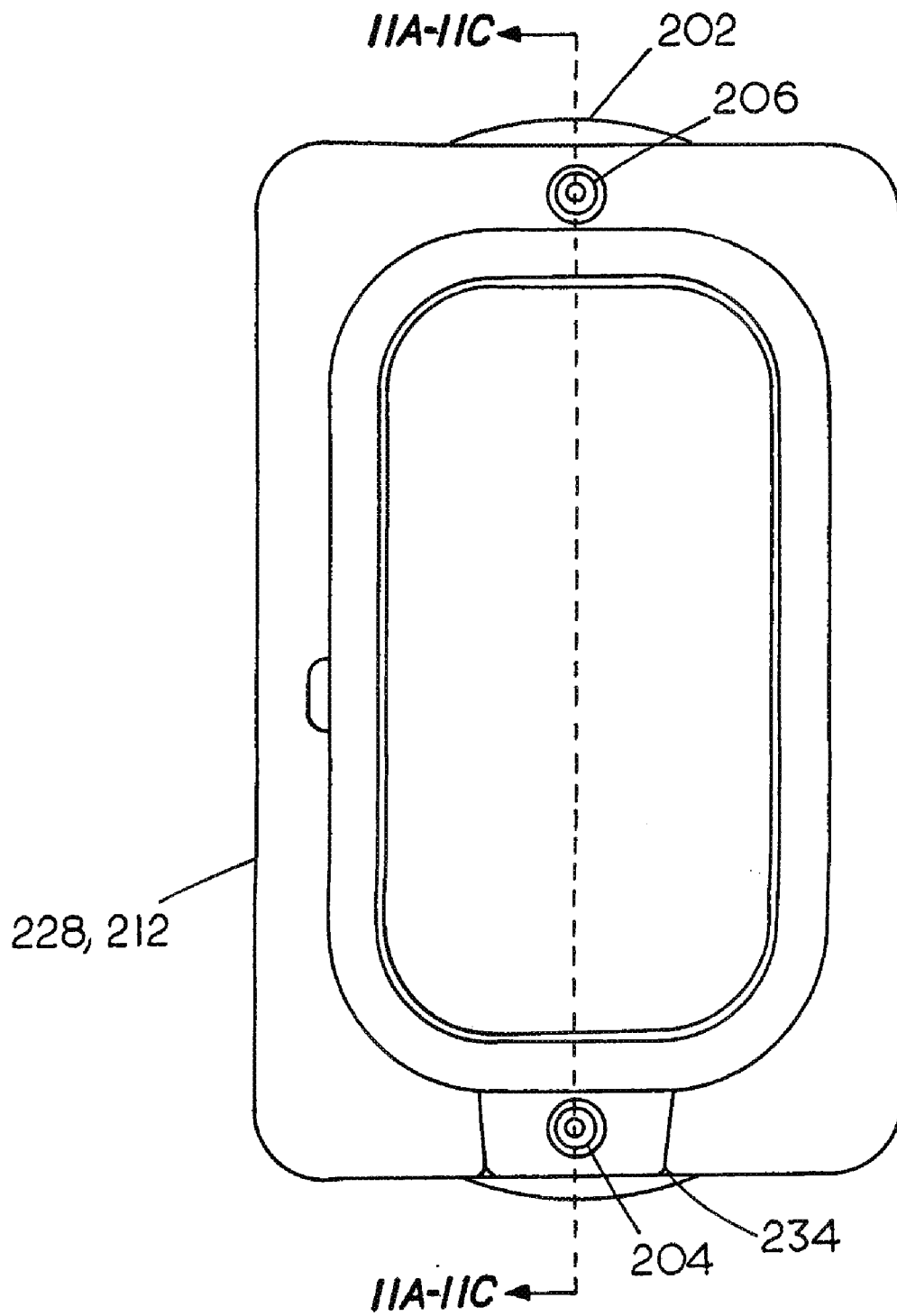

FIG. 13

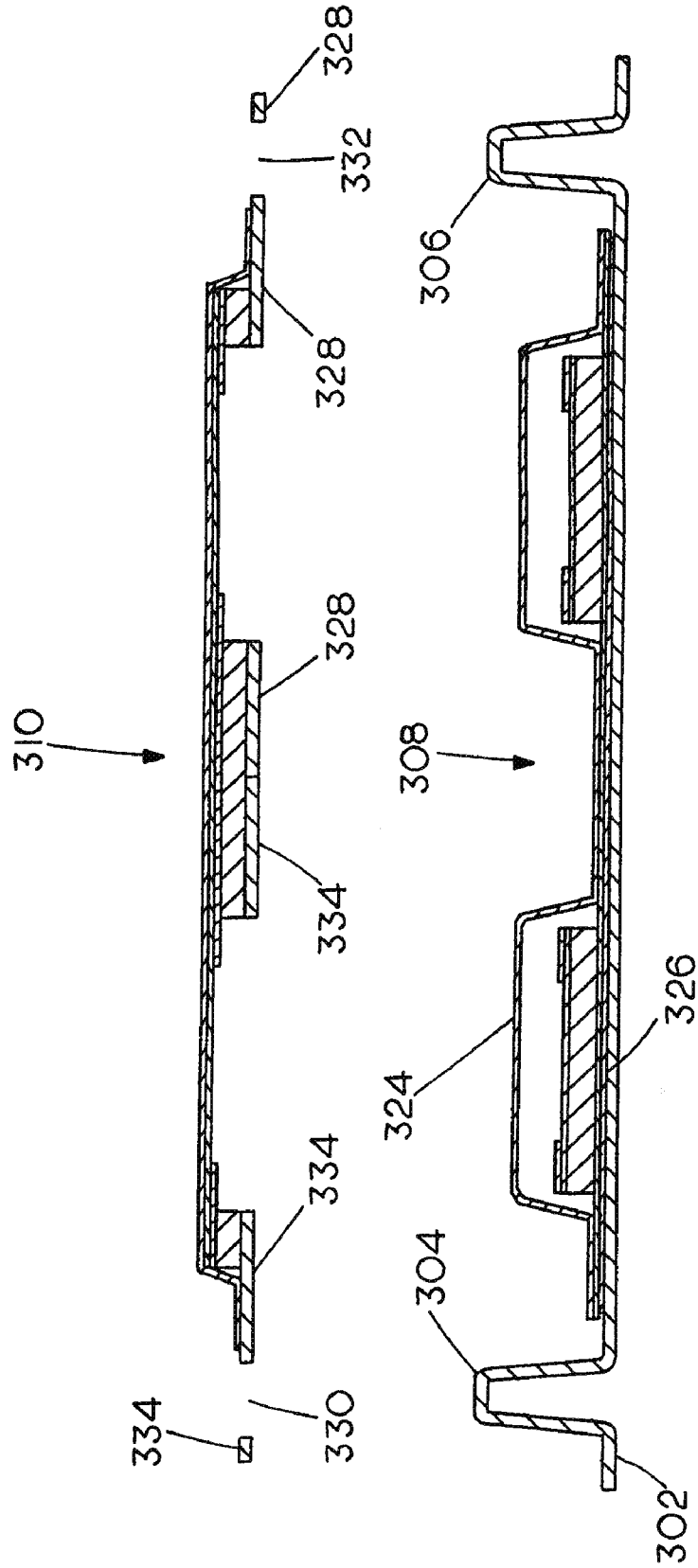
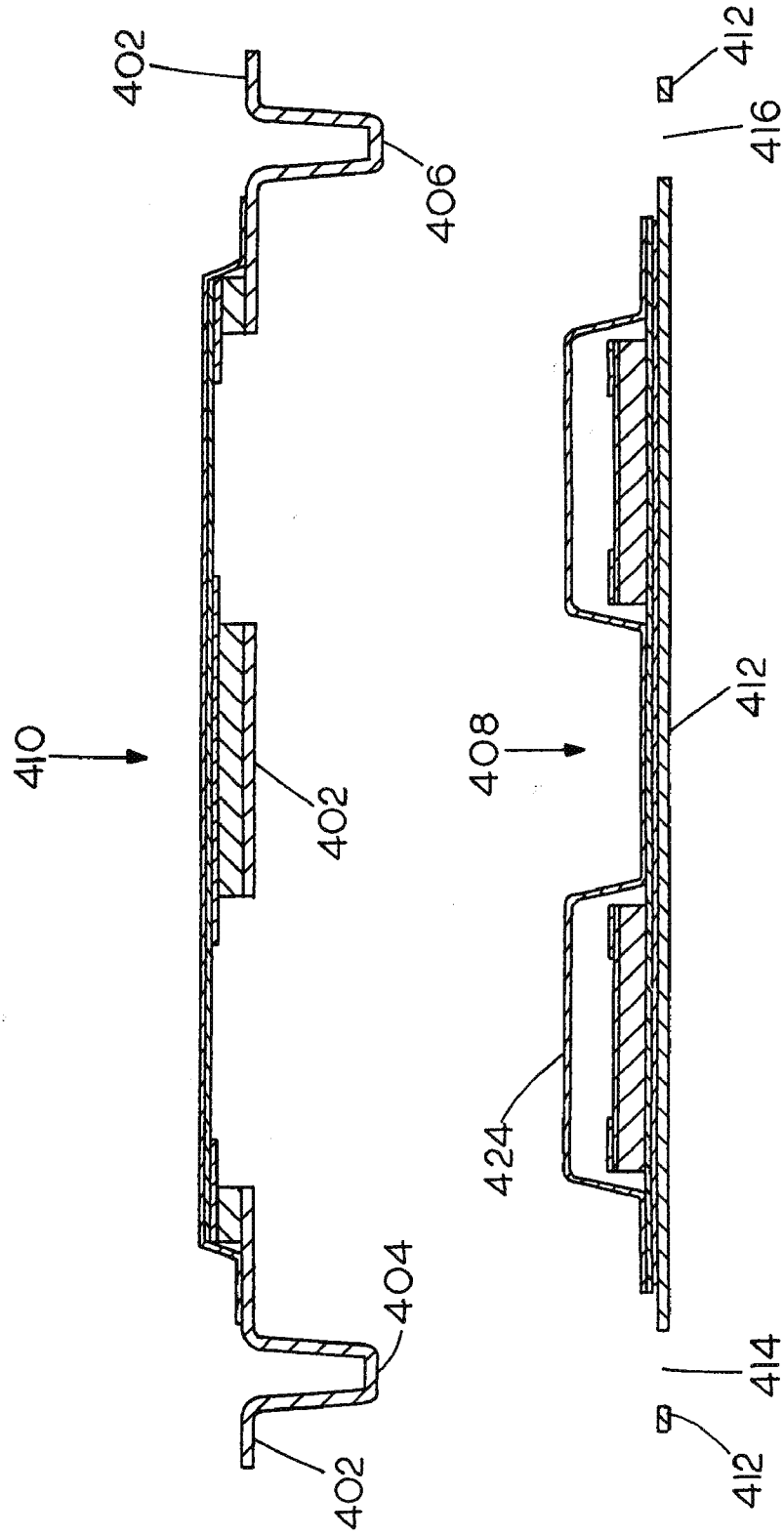

FIG. 14



IONTOPHORETIC DRUG DELIVERY PACKAGING

CROSS-REFERENCED TO RELATED APPLICATIONS

[0001] This application is a non-provisional application of Application No. 61/094,442, filed Sep. 5, 2008 and claims priority from that application which is also deemed incorporated by reference in its entirety in this application.

BACKGROUND OF THE INVENTION

[0002] I. Field of the Invention

[0003] The present invention relates generally to iontophoretic drug delivery systems for transdermal delivery of therapeutic agents and, more particularly, to packaging such systems for long shelf life and easy assembly for use. The system package includes an iontophoretic skin worn patch component that accommodates a power source, electronics, electrodes and a drug pack component that carries a therapeutic agent which is contained as a separate sealed component. The packaged system further provides for ease of assembly at the time of use.

[0004] II. Introduction

[0005] The process of iontophoresis is well known and has found significant commercial use in the delivery of ionically charged compounds across the skin at the sites of system electrodes of like charge.

[0006] Self-contained, wearable iontophoretic systems have been developed in which the electrical circuitry and power supply have been integrated into a single, skin-worn patch. In many of these devices, drug ions are delivered into the body from an aqueous 'drug' reservoir contained in the iontophoretic device, and counter ions of opposite charge are delivered from a 'counter' reservoir. Because drug/ion solutions are often stored remotely in bulk quantity and introduced to an absorbent layer of the iontophoresis electrode of interest at the time of use, additional steps are necessary to incorporate drug ions and counter ions into the device. However, the electrodes can be easily over-filled or under-filled, thus this aspect requires trained personnel with good technique. Additionally, because the drug solution is stored separately from the electrodes, management of two inventories is required.

[0007] To avoid the need for users to incorporate the aqueous drug or ion reservoir at the time of use, the drug solution can be pre-packaged with an electrode, or an aqueous reservoir can be stored in contact with an electrode assembly, and a dry medicament layer introduced to the aqueous reservoir at the time of use. Unfortunately, with either configuration, an electrode is still stored in wet environment, and that and other components may succumb to corrosive deterioration.

[0008] For the above and other reasons, co-packaging iontophoretic transdermal drug delivery patches with active pharmaceuticals remains a challenging problem. Because iontophoretic patches contain electrodes and electronics and the drug solution is usually aqueous in nature, without a barrier between the aqueous environment and the electronics, degradation of both the electronics and the drug solution will occur within the desired shelf life, which may be 2 years. A packaging solution that provides a barrier and therefore meets shelf life requirements between the electronics and the drug solution, yet still allows the drug solution and electrodes to be combined in an assembled device at time of use is sought. A

solution that not only addresses shelf life stability issues surrounding co-packaging aqueous drug solutions with electrodes and electronic circuits but which also makes it easier for the operator or user to activate and apply the patch is even more desirable.

SUMMARY OF THE INVENTION

[0009] The present invention presents a pre-packaged complete iontophoretic drug delivery system that is easily assembled from the packaged state. Pre-packaged complete iontophoretic drug delivery systems of the invention include both an iontophoresis patch and an agent to be administered and enjoy a long shelf life. The system includes two main components, namely, a drug pack component containing one or more absorbent pads, at least one of which contains an active agent, and an iontophoresis patch component which contains electrodes and a source of electric power. The drug pack and patch are packaged together, but as separated components during storage of the system. They are readily incorporated into an assembled state at the time of use by the use of a built-in alignment technique that employs an alignment structure that may take any of several forms. One form includes a conjoined folding platform or support structure that carries the components on separate panels and another involves the use of a separate alignment fixture or guide element.

[0010] In one embodiment, an iontophoresis patch component and a sealed therapeutic ion-containing or an active ingredient-containing drug pack (also known as a "blister pack") component are carried in a distinct arrangement by consecutive supporting panel structures in a configuration that is designed to fold on itself in different manners to accommodate both storage and use. This type of an arrangement may be characterized as a folding configuration or folding support structure.

[0011] Alternatively, an iontophoresis patch and a sealed drug pack may be stored as separate components in a package and assembled together using an alignment fixture or guide element prior to use. The alignment fixture or guide element may be a separate component or may be packaged as initially attached to either the iontophoresis patch or the drug pack.

[0012] In addition, while most drug or therapeutic ion species generally will be contained in gel form in the drug pack, some may be carried in a dry state in the iontophoresis patch. In this arrangement, the therapeutic ion species is combined with the gel or other solution upon assembly of the system.

[0013] The folding embodiment features a plurality of consecutive conjoined panels in a platform or support structure in which a transdermal, iontophoretic patch is affixed to one panel support structure and a formed and sealed therapeutic agent chamber or drug pack is affixed to an adjacent panel with the corresponding drug and electrode parts in aligned registration and an appropriate fold line therebetween. The folding support configuration or platform preferably is fabricated with a paper board or polymer material with selectively applied release coatings and pressure sensitive tapes for affixing the transdermal patch and drug pack to the panels. The transdermal patch includes all necessary adhesive tapes, liners, electrodes, and circuit elements of a typical iontophoretic patch device except a drug imbibed absorbent pad.

[0014] The sealed drug pack is formed using low moisture vapor transmission materials and contains at least one permeable absorbent pad imbibed with the desired drug solution

generally in gel form. The drug imbibed pad or pads remain separately housed in a sealed drug pack during its shelf life until time of use.

[0015] The folding configuration contains cut outs and fold lines to allow and guide various panels to fold inward or collapse on top of one another and includes a release coating (which may be siliconized) applied to the back surface with a coating on the front side having a surface on which printing can be applied. The printable coating surface may include a conventional clay material. The transdermal patch is affixed to a first panel on the release-coated or back side of the platform. The drug pack is bonded to the adjacent panel on the printable or clay coated front side. The folding system further contains cut outs in the shape and position of the adsorbent pads on the transdermal patch panel which allows the patch to communicate and register with the contents of the drug pack when the system is folded. As indicated, the patch and drug pack are registered to the panels so that when the system is folded together in an assembled arrangement, the formed blisters or drug chambers of the tray are aligned with corresponding wells of patch electrodes.

[0016] In certain of these embodiments where a folding support structure associated with said drug pack component and said iontophoresis patch component is present, the folding support structure may further include a separator component configured to physically separate the drug pack and iontophoresis patch components when the iontophoretic drug delivery system is present in a folded storage stage. As described above, in these embodiments the support structure may include a first panel that is associated with the iontophoresis patch component and a second panel that is associated with the drug pack component, where these first and second panels are joined by a fold line. The support structure further includes a separator component that is made up of one or more additional panels, e.g., joined to the second panel on a side opposite the side that the second panel is joined to the first panel, where these additional one or more panels are configured to physically separate the iontophoretic and drug pack components when the system is in the folded storage state, e.g., see FIG. 9A. The separator component not only separates the drug pack from the patch component in the folded storage state, but also acts as a protective packaging for the system components.

[0017] Storing the aqueous drug imbibed absorbent pad or pads in a generally inert sealed blister or drug pack prior to use prevents the contents from interacting with the surroundings, thereby, preventing any degradation of the drug solution or of any electronic or other patch components housed in proximity to the drug pack. In accordance with preserving the integrity of the contents, the materials in direct contact with the drug solution during storage are preferably limited to relatively inert materials. These include a formed tray, the absorbent pad and the lid or barrier layer of the blister or drug pack. Materials of low water vapor transmission include vinyls, polyesters, polyamides, including nylon, or polyalkylenes, such as polyethylene and polypropylene. The material may further be coated on one or both sides with a material selected from a diverse fabric, foil, metalized film or other materials to reduce water vapor transmission still further. The tray and lid also should be formed of materials that are inert to or stable in the presence of the components of the drug solution and absorbent pads.

[0018] One embodiment includes a tray and lid of a composite aluminum/polymer material. The lid is provided with

an easily peeled seal layer for easy removal at the time of use. In that embodiment, the absorbent pads consist of a lamination of suitable polymer layers and coatings that are stable in the presence of and contact with the drug solution. The absorbent pads are preferably of a non-woven matrix which has a known gel absorbency or take-up rate. Examples of materials that may be suitable for the absorbent non-woven matrix include cotton, polypropylene, polyethylene, and polyester. Preferably, the absorbent material is polypropylene.

[0019] Alternate embodiments assemble the drug delivery device system from separate components using an alignment fixture or guide element which may be furnished as a separate component or combined with a transdermal iontophoretic patch or a drug pack. Separation of the assembled wearable iontophoresis device and drug pack is similar in each case and the construction of the iontophoresis patch and drug pack is similar to that described in connection with the folding embodiments.

[0020] In the case of the folding panel embodiments, at time of use, the operator first peels off the formed drug pack tray lid held by the seal layer material exposing the drug imbibed pad or pads which remain affixed to a panel of the system. The patch component is attached to an adjacent panel. Next, the operator folds the panels together bringing the drug imbibed pads in intimate contact with the wells of the patch electrodes. The patch electrodes are provided with a ring of adhesive that bonds to a matching ring layer portion of the surface of the absorbent pads when the two are brought into contact. The patch is then peeled from a siliconized or other suitable release coating on the support configuration leaving the drug-imbibed pads now permanently attached to the electrodes of the patch by the peripheral adhesive. Finally, the patch is applied to the patient. Multiple embodiments or variations around this basic concept and method are contemplated.

[0021] Embodiments with a separate alignment fixture component or guide element are assembled by registering alignment openings in drug pack and iontophoretic patch support structures consecutively with guide members on an alignment fixture or guide element. The drug pack on its flat substrate is first assembled on the guide element and the lid is removed as in other embodiments. Next, the iontopatch is assembled on top of the open drug pack which again places gel-imbibed pads of the drug pack in alignment with corresponding electrodes. This again results in a combined configuration in which the drug-imbibed pads are permanently bonded to the electrodes by peripheral adhesive and in which the assembly can be separated and applied to a patient. In alternate embodiments, the guide element can be packaged assembled and carrying the blister or drug pack component and the iontophoretic patch component assembled to that combination or the iontophoretic patch component can be packaged assembled to the guide element and thereafter combined with the drug pack component.

BRIEF DESCRIPTION OF THE DRAWINGS

[0022] In the drawings wherein like characters denote like parts throughout the same:

[0023] FIG. 1A is an exploded cross sectional view through an embodiment of a folding iontophoretic drug delivery system;

[0024] FIG. 1B is an assembled view of the device shown in FIG. 1A;

[0025] FIG. 1C is a greatly enlarged, fragmentary cross section of a portion of the folding support structure of FIGS. 1A and 1B showing release coating and printable layers.

[0026] FIG. 2 is a top view of the embodiment shown in section in FIGS. 1A and 1B;

[0027] FIGS. 3A-3D are cross sectional views illustrating a step-wise activation and deployment of the device of FIG. 4;

[0028] FIG. 4 is a top view of the embodiment in FIGS. 3A-3D with the formed lid removed from the drug package;

[0029] FIGS. 5A-5E are cross sectional views illustrating a step-wise method and design for packaging the drug and saline gels on non-woven absorbent pads;

[0030] FIG. 6 is a top view of the embodiment shown section in FIGS. 5A-5E as assembled;

[0031] FIGS. 7A and 7B are top and cross sectional views, respectively, of the absorbent pad of the embodiment of FIG. 6;

[0032] FIGS. 8A and 8B are top and cross sectional views, respectively, of an alternative embodiment of an absorbent pad;

[0033] FIG. 9A is a side view of a folding iontophoretic drug delivery system in accordance with the invention in a folded packaged (stored) configuration;

[0034] FIG. 9B is a top view of the packaged configuration of FIG. 9A;

[0035] FIG. 10 is a top view of an alternative embodiment of the device in an opened, flat configuration;

[0036] FIG. 11A depicts an exploded cross-sectional view through an alternate embodiment of the device of the present invention with separate iontophoretic patch and drug pack components and a guide element;

[0037] FIG. 11B is a cross-sectional view depicting the exploded parts of FIG. 11A assembled together;

[0038] FIG. 11C depicts the separation for use of the assembled transdermal iontophoretic drug delivery system of FIGS. 11A and 11B;

[0039] FIG. 12 is a top view of the assembly of FIG. 11B;

[0040] FIG. 13 is an exploded cross-sectional view of another embodiment alternative to that shown in FIGS. 11A-11C with the drug pack carried by the guide element; and

[0041] FIG. 14 is an exploded cross-sectional view of still another embodiment alternative to that shown in FIGS. 11A-11C.

DETAILED DESCRIPTION

[0042] The invention provides for a fully functional, self contained, easy-to-use iontophoresis device in the form of a pre-packaged drug delivery system which enjoys a relatively long stable shelf life. The system contains a drug reservoir pack, folding panel support structure construction, and a transdermal patch containing a power source, current controlling electronics, and electrodes. The device is ready to use and requires only a few simple operations to activate and apply the patch to a treatment site. The operations in some embodiments consist of removing a drug pack barrier lid, folding the panels onto themselves, and peeling the patch from a release coating. In others, the transdermal patch and drug pack are assembled on an alignment fixture or guide element which is then removed. Several preferred embodiments of the devices will be described below to illustrate the concepts of the invention, but they are not meant to limit the scope of the inventive concept in any manner.

[0043] FIGS. 1A, 1B, and 2 respectively show exploded cross sectional, assembled cross sectional, and top views of

one embodiment of a folding device, generally at 20, in an opened or flat configuration. FIGS. 9A and 9B respectively show the embodiment in a side cross sectional and top view of the device folded in a packaged configuration for long term storage. The device consists of 3 main elements: a folding support structure 22, a transdermal iontophoretic patch 24, and a drug containing pack or blister pack 26.

[0044] The folding support structure 22 may include a paperboard, or similar material, substrate with a release coating layer 28 applied to one side and a printable coating 30 applied to the opposite side. FIG. 1C is a greatly enlarged representative fragmentary cross section of a portion of the folding support structure 22, further illustrating the coating layer 28 and printable coating 30. The release coating layer 28 may be a siliconized coating and the printable coating 30 may be a clay coating. An alternative folding substrate or support layer may be a thermoformable polymer or the like. The support structure 22 may contain several fold lines as at 32, 33 and 34 that are created by perforating, scoring, and/or creasing. In the case of a thermoformable substrate, living hinges may be thermoformed at 32, 33 and 34. Depending on the number of fold lines, the support structure may be divided into a number of panels which provide areas to attach various components of the device, apply printing for directions, and/or provide a release coated barrier for exposed adhesives on one panel from permanently sticking to other panels when folded together during storage.

[0045] As shown, transdermal iontophoretic patch 24 is adhesively attached to a first panel 36A of the support structure 22 on the release coated side of the substrate. The transdermal iontophoretic patch 24 includes an adhesive coated foam layer 38, an occlusive double sided tape layer 40, an electrode subassembly layer 42 consisting of a power source, electronics and electrodes to operate the patch (not shown), and an overlay tape layer 44. As shown in FIG. 1B, the adhesive side of the foam and the overlay tape are attached to the release coated side of the support structure.

[0046] As shown in FIG. 2, cut outs in the foam layer 38 and support structure 22 layers create an empty anode well or recess 46 and an empty cathode well 48 aligned to receive the corresponding anode and cathode imbedded drug pads, preferably gel pads during assembly/activation. The anode and cathode cut outs 46, 48, respectively, expose underlying electrodes, including anode 50 and cathode 52. A half-panel release liner 54 is created by perforating the first panel 36A as also shown in FIG. 2. The half-panel release liner 54 serves to peel the patch off of the substitute layer of the support structure after it is activated.

[0047] The half-panel release liner serves the purpose of stiffening the flexible patch to aid in application and additionally allows the operator to handle the patch easily without the patch sticking to the operator's fingers. Preferably, the half of the patch not covered by the half-panel release liner 54 is affixed to the patient's skin first. Subsequently, the half-panel release liner is removed by peeling at a tab 54A of the half-panel release liner. Finally, the other half of the patch is affixed to the patient's skin.

[0048] A strip of double-sided tape 56 is attached to the printable side of the support structure 22 on the first panel 36A. The adhesive strip 56 serves a dual function of keeping the structure closed during its long term storage condition by temporarily bonding to a release coated side as shown in FIG. 9A. The second function is to permanently bond to a second panel 36B of the support structure when the parts are folded

together to transfer the anode and cathode gel pads **60**, **62** as shown in FIG. 3C so that the first panel **36A** cannot be re-opened.

[0049] As shown in FIG. 9A, the support structure also includes third and fourth panels **36C** and **36D**, respectively. Third and fourth panels **36C** and **36D** collectively make up a separator component that is configured to physically separate the drug pack and iontophoresis patch components when the iontophoretic drug delivery system is present in a folded storage stage. The third and fourth panels **36C** and **36D** of the support structure **22** as folded create a release coated barrier that prevents the occlusive tape **40** in the transdermal patch **24** from touching and permanently sticking to the formed lid layer **64** of the drug pack **26** during long term storage.

[0050] As shown in FIG. 2, when the system is present in a pre-folded state prior to storage, the drug pack components are present in the center region of the support structure and flanked on a first side by the iontophoresis patch component and on a second side opposite the first side by the separator component of the support structure which affords both structured separation and external protection for the stored system.

[0051] A second piece of double-sided tape **66** is attached to the second panel **36B** on the printable side of the support structure **22** to permanently bond the drug containing blister pack **26** to the support structure **22**. Alternatively, for example, instead of a double-sided adhesive **66**, the drug containing blister pack **26** could be heat sealed to the support structure **22** as by applying a heat seal coating to the bottom of the drug containing pack or to the printable side of the support structure.

[0052] As indicated, the drug pack **26** is provided with a formed barrier lid having low moisture vapor permeability, a generally flat bottom layer, containing two spaced gel locations, one containing an anode gel-imbibed non-woven pad **60**, another containing a cathode gel-imbibed non-woven pad **62**. The low moisture vapor permeable barrier formed lid layer is shown at **64**. Preferably, the generally flat bottom layer **68** is constructed of an aluminum foil composite film that may or may not contain a heat seal coating (not shown) on the side that contacts the gel pads. If it is used, the heat seal coating is preferably a readily peelable coating.

[0053] The gel-imbibed pads as at **70** are constructed of a composite or laminated non-woven material. The anode and cathode gels are dispensed onto the pads and soak into the composite non-woven material.

[0054] The low moisture vapor permeable formed lid layer **64** has been successfully constructed from a cold-formable aluminum composite material consisting of a seal layer on the product contacting under side **64A** and a nylon layer on the opposite side **64B**. Alternatively, for example, the product contact side **64** may consist of PVC with no seal layer. If a seal layer is employed, preferably it is a peelable heat seal coating. Anode and cathode cavities **72** and **74**, respectively, may be mechanically formed with traditional cold form tooling using Teflon® (polytetrafluorethylene) plugs or in combination with vacuum or pressure assist. The material may be thermoformed if using an alternative material including other fluorine-containing plastics in sheet or film form such as material sold under the trademark Aclar®, PVDC, and other low moisture vapor transmission barrier thermoformed packaging materials.

[0055] FIGS. 7A and 7B show top and side cross-sectional views, respectively, illustrating the structure of one embodiment anode **72** or cathode **74** composite pad materials. As indicated, the anode and cathode pad composite materials are preferably of a non-woven structure to maintain the continuity of the drug-containing material in the structure and may

include a plurality of layers, possibly up to three layers, of material. These may include a thick needle-punched polypropylene layer **76**, a thin, permeable polyethylene net layer **78**, and a thin, occlusive polypropylene layer **80**. The layers may be heat fused together without requiring adhesives. All three layers are cut to have the same outside perimeter shape. The occlusive layer **80** is cut to the shape of a perimeter ring that remains intact and occlusive. Inside the ring, the occlusive layer **80** is cut out completely or perforated so that the inside region **84** becomes permeable. The permeable region **84** is shaped to coincide with the shape of the anode **50** and cathode **52** electrodes, by allowing the gel to migrate through this layer and contact the full area of the electrodes when the device is assembled for use. Importantly, the occlusive ring **80** provides a barrier for gel migration so the outside surface remains relatively dry during storage to aid in adhesive transfer of the drug-imbibed pad **70** during activation of the device.

[0056] In one embodiment, both the anode **72** and cathode **74** composite pads are similar in shape. Of course, the electrodes may be any convenient shape and the electrodes in a given patch embodiment may be of like or different shapes. FIGS. 8A and 8B show a plan view and cross sectional view of an alternate shape of what may be either an anode and/or cathode of composite non-woven material **86**. This embodiment has a shaped perimeter ring **88**, with permeable inside area **90**. FIG. 10 is a top view of an alternative embodiment showing a device **100** with a drug pack **102** having anode and cathode formed cavities, **104** and **106**, respectively, of different shapes. In similar fashion, anode and cathode formed cavities of different, but corresponding shapes, are reflected in the anode **108** and cathode **110** in the foam, support structure **22**, and occlusive layers **114** and **116**. Only corresponding components that fit together in an assembled device need be of like shape.

[0057] An important aspect of the invention involves shelf life stability of the co-packaged iontophoretic devices. This is of paramount concern based on the history of such devices which have had limited commercial success because of shelf life limitations. As indicated, co-packaging techniques have included attempts to package the wet drug gels in direct contact with the electrodes during long term storage, and attempts to isolate the power source and electronics in the same package through low moisture permeable (high barrier) materials. Wet gels have been packaged in direct contact with the electrodes only and connected to a power source and electronics by a cable or other connector at time of use. As indicated, each of these is fraught with challenges for long term stability. For example, in time, wet gels may degrade the metals in the electrodes, power source, and electronics which, in turn, contaminates and degrades the stability of the gel.

[0058] In the present development, stable long term co-packaging is realized by the provision of a storage container for the anode and cathode gels in the form of a separate hermetically sealed drug pack or blister cavity with product contact layers that do not leach into the gel, react with the gel, or absorb the gel. Since the gel material itself provides no form, a carrier substrate material is used to give the gel form and structure, and provide a stable support to facilitate transfer of the gel out of the long term storage container when the system is assembled for use. The carrier substrate should be composed of materials that do not leach, react, or absorb the constituents of the gel. Preferably the blister cavity and carrier substrate should be made from stable, relatively inert, materials such as polypropylene and polyethylene. Any suitable material can be used and may be selected based on the nature of the gel.

[0059] Shelf life stability will vary with the construction of the patch component and the stability of the integrity of the drug composition. Patch shelf life depends on retention of adhesive quality and the maintenance of the specified function of the electrical circuit components. The device should have a stable shelf life of at least two (2) years.

[0060] FIGS. 5A-5E show in step-wise cross sectional views of one method for forming, filling, and sealing a drug-containing pack or drug pack in accordance with the present development. FIG. 6 shows a top view of the drug pack of FIG. 5, as assembled generally at 120. In the method of FIGS. 5A-5E, the drug containing pack is assembled in an inverted position. The assembly starts with the provision of a lid or cover membrane 122 of a low moisture vapor transmission material formed to create anode and cathode gel cavity shapes 124 and 126, respectively, at a specified spaced interval and depth. Next, an anode pad 128 is placed into the formed anode cavity 124, and likewise, a cathode pad 130 is placed into the formed cathode cavity 126. The pads may be of similar construction to those shown in FIGS. 7A-7B and 8A-8B. The anode and cathode pads are oriented so that each occlusive layer 132, 134 is placed facing into the cavity and in contact with the bottom of the corresponding formed cavity. The anode and cathode pads are sized to just fit in the bottom of the formed cavities. In this manner, the formed cavities then initially provide registration of the pads to the formed lid layer 122.

[0061] The remaining steps are performed in a timed sequence as will be described. Allowable open time for the assembly is determined by the rate of pad permeation which is related to the viscosity of the gel used.

[0062] At time $t=t_0$, as shown in FIG. 5C, an amount of a viscous anode gel 136 is dispensed to uniformly cover the central permeable region as at 84 (FIG. 7A) of the anode pad 128; similarly, an amount of a viscous cathode gel 138 is dispensed to uniformly cover a permeable region of the cathode pad 130. As also seen in FIG. 5C, both the anode and cathode gels are dispensed in a manner such that for a given amount of gel, once dispensed, the total height of the pad plus the gel height somewhat exceeds the depth of the formed anode or cathode cavity 124 or 126. The gel must be of a relatively high viscosity range in order for it to maintain its shape/height for a necessary duration during assembly of the device. At time $t>t_0<t_1$, a flat bottom or carrier substrate layer 140 is applied (FIG. 5D) and heat sealed to the formed cover membrane 122. Application of the flat carrier substrate layer 140 contacts and compresses the gel causing the gel to wet the inner surface of the carrier substrate layer 140 and spread out as also shown in FIG. 5D.

[0063] Alternatively, in another embodiment (not shown), the flat bottom layer can be formed similarly to the formed cover membrane layer to create a nested configuration, in which case, the gel plus the pad height can be designed so that when the bottom and lid layers are assembled, the gel will be in contact with the carrier substrate layer in a similar manner as in the illustrated embodiment.

[0064] In this procedure, time span $t=t_0$ to $t=t_1$ is defined as the time it takes the dispensed anode and cathode gels to soak through their respective pads and start to wet to the bottom of the formed cavities of 11d layer. Time is a factor because it has been found that if the gels soak completely through the respective pads and wet the bottom or inner surface of the formed cover membrane cavity before the carrier substrate layer is applied, the pads, once fully imbibed, may preferentially stick to the inside of the formed lid. This, of course, is undesirable as the imbibed gel pad would adhere to the lid layer 122 instead of the carrier substrate layer 140 when one

attempted to assemble the system. Time span $t=t_0$ to $t=t_1$ also defines the time in which the gel will adequately maintain its height so that the gel will wet and adhere to the inner surface of the bottom layer 140 when that layer is applied.

[0065] For the above reasons, the gels are formulated in a preferred viscosity range to provide the correct flow rate and surface tension. For example, a 100,000 centipoise gel may have a t_0-t_1 time window of about 2-4 minutes. This is adequate for normal assembly to occur.

[0066] In this process, the gels initially contact and wet the bottom layer member 140. This allows the gels to act as adhesives as the surface tension of the gels between the member 140 and the pads 128 and 130 exceeds the gravitational forces on the imbibing pads. Therefore, as the pads slowly imbibe with gel, they will stick to and be pulled towards the carrier substrate layer regardless of the orientation of the device. Thus, after the bottom and lid layers are sealed, the compressed gels imbibe (soak-in) into the anode and cathode pads respectfully, creating a fully imbibed non-woven anode pad 128a and fully imbibed pad 130a as shown in FIG. 5E. As described previously, the fully imbibed anode and cathode gel pads continue to adhere to the bottom layer 140 thereby creating anode and cathode headspaces 142 and 144, respectively in the package as also shown in FIG. 5E. It has been found that due to the high surface tension and high preferred viscosity of the gels, the fully imbibed pads will remain registered to their respective formed lid cavities and be attached to the carrier substrate layer as shown throughout the anticipated shelf life of the device.

[0067] It will be appreciated that the amount of gel added to each cavity should be matched to the absorbency of each pad in order to minimize excess gel. The amount and viscosity of the gels is preferably such that imbibed gel does not wet the outer surface of the occlusive ring on the pads. In this manner, the outer surface of the occlusive ring 146, 148 should remain relatively dry to aid adhesive transfer and adhesive attachment of imbibed gel pads into corresponding empty anode and cathode wells of the transdermal patch during activation. The inside surface of the formed lid cavities in the anode and cathode headspace regions as at 142 and 144 should remain free of gel and relatively dry.

[0068] In order for this packaging concept to function, the gels must be formulated with a preferred viscosity. The preferred range is between 8,000-120,000 centipoise but is not limited so long as the process can be successfully followed. The gels useful in the system may be formulated by dissolving an appropriate amount of drug or saline in water, and adding a gelling agent such as HPMC (hydroxypropylmethylcellulose) such that a conductive gel of appropriate viscosity is created. Other gelling agents, such as PVP (polyvinylpyrrolidone), PEO (polyethyleneoxide), or PVA (polyvinylalcohol) can also be used. Successful gels have been formulated from a HPMC powder at 2% w/w.

[0069] The concentration of an active agent in the gel may vary widely depending on the agent of interest and the desired patch dosage and planned duration of application. Generally, the concentration will range from about 0.2% to 10% (weight).

[0070] FIGS. 3A-3D show in step-wise fashion, in cross-sectional views, how one preferred embodiment is activated and deployed to a treatment site. FIG. 4 shows the top view of FIG. 3A after the blister or drug pack lid 64 has been removed. FIGS. 9A and 9B show a side sectional and top view, respectively, of a fully packaged device.

[0071] Beginning with the fully packaged device of FIGS. 9A and 9B, a deployment or assembly process will be described. First, the fully packaged device is opened and

unfolded by pulling at the tab **160** to release adhesive strip **56** from the release liner coated side of panel **36D**. Second, the formed cover membrane layer **64** is removed or peeled away from the bottom layer **68** exposing the gel-imbibed anode and cathode pads **60**, **62** which are adhered through surface tension of the gels to the bottom layer **68** as shown in FIG. 3A. The peel is initiated by peeling at the tab **78** (FIG. 2) on the formed lid member **64**.

[0072] Next, the first panel **36A** is folded at the fold line **32** onto the second panel **36B**, thereby bringing the occlusive region as at **80** of the occlusive layer **80** of the anode and cathode gel pads **60**, **62** in permanent adhesive contact with the occlusive tape layer **40** of the transdermal patch **24** as shown in FIG. 3C. Also, the adhesive strip is brought into contact with the printable coating layer **30** of the support structure **22** and is permanently adhered to the second panel **36B**, thereby preventing the panel **36A** from being re-opened. FIG. 3B shows an intermediate view of the folding action. The outer surface of the transdermal patch is preferably pressed to ensure good permanent bonding of the occlusive tape **40** to the occlusive region as at **80** on the gel pads.

[0073] Finally, the half release liner **54** is peeled from the support structure at the tab **54A** bringing the fully assembled transdermal patch **170** with it. The exposed half of the patch adhesive can be applied to the treatment site and the half release liner **54** thereafter can be peeled from the transdermal patch at the tab **54B** (FIG. 9B) and the remaining half of the patch adhered to the treatment site.

[0074] FIGS. 11A-11C illustrate an alternative embodiment including an alignment fixture or guide element and illustrating activation of the embodiment. FIG. 12 shows a top view of the fully assimilated embodiment of FIG. 11B from which the cross-sectional views of 11A-11C are taken. As best seen in FIG. 11A, the device, generally **200**, as packaged, includes three main components. They are a guide element **202** having spaced raised alignment members **204**, **206**, a drug pack arrangement **208** and a transdermal patch assembly **210**. The main components are designed to be stored separately in a common package and assembled when the device is prepared for use.

[0075] The drug pack includes a flat card substrate layer **212** which is designed with spaced alignment openings **214** and **216** which register with alignment members **204** and **206** during assembly. Anode and cathode non-woven, gel-imbibed pads **218** and **220** are respectively carried on a bottom layer **222** and separated from drug pack lid **224** in the manner of embodiments previously described and illustrated in FIGS. 5A-5E. Drug pack **208** is adhered to card substrate layer **212** as by a double-sided tape layer at **226**.

[0076] The transdermal patch component **210** is mounted on a flat card substrate layer **228** with spaced alignment openings **230** and **232** and, as with previously described embodiments, half release liner **234**. The patch assembly may be quite similar in construction to that previously described with foam layer **236** and double-sided tape **238**, electrode subassembly layer **240** and overlaying tape layer **242**.

[0077] At the time of use, individual components are aligned and assembled to each other using features of a component to self-align to adjacent components. In this manner, the guide element **202** may be positioned on a flat surface with the spaced alignment members **204**, **206** facing up as shown in FIG. 11A. Next, the drug blister pack **208** is assembled to the alignment fixture or guide element **202** by registering alignment member **204** to the opening **214** in the drug pack and alignment member **206** to opening **216**. The lid **224** can then be peeled off the drug pack **208** exposing the gel-imbibed, non-woven anode and cathode pads **218** and **220**,

respectively. Next, the transdermal iontophoresis patch **210** can be assembled to drug pack **208** by again using alignment members **204** and **206** with alignment openings **230** and **232** thereby placing the gel-imbibed pads in alignment with corresponding electrodes. This results in the combined configuration depicted in the cross-sectional view of FIG. 11B and top view of FIG. 12 with the drug pack arrangement **208** and the transdermal patch assembly **210** in consecutive assembled registration on the guide element **202**.

[0078] In this stacked condition, the assembled patch is ready to be separated for placement on a patient. Separation can be accomplished by simply peeling the half release liner **234** from the card thereby separating the device from the card substrate layer **228** and bringing the fully assembled transdermal patch **250** with it as shown in FIG. 11C. The patch is then ready to be applied to the patient as described in relation to the previous embodiments.

[0079] It will be appreciated that the drug pack **208** and the transdermal patch **210** are similar in construction to previously described embodiments except that the card substrate layers in this embodiment are separate flat members rather than folding connected panels. The flat card substrate layers **212**, **228** include alignment openings corresponding to the members **204** and **206** on guide element **202** and they do not require a silicon or other release coating so that both sides may contain a printable clay coating material or the like.

[0080] The card layers **212**, **228** may also be constructed from any suitable polymer material. The alignment members **204** and **206** of the guide element **202** are preferably thermoformed or injection molded out of a suitable polymer material also.

[0081] FIG. 13 is an exploded cross-sectional view of an alternate embodiment to that shown in FIGS. 11A-11C in which a guide element **302** with alignment members **304** and **306** is substituted in the drug pack **308** for the flat card substrate layer **212**. The drug pack is otherwise similar to previously described drug packs and a lid is shown at **324**. The transdermal patch component **310** is also similar to that shown in FIG. 11A and includes substrate **328** with spaced alignment openings **330** and **332** and half release layer at **334**. The drug pack **308** is bonded to the guide element **302** by double-sided tape **326**.

[0082] Assembly and activation is similar to that of the embodiment of FIG. 11A-11C. Thus, the drug pack lid **324** is removed and the transdermal patch **310** is aligned with the drug pack over the alignment members **304** and **306** using the openings **330** and **332**. The assembled patch thereafter being peeled away in the manner of FIG. 11C.

[0083] FIG. 14 shows an exploded cross-sectional view of yet another embodiment of the device of the present invention which represents another alternative to that shown in FIGS. 11A-11C. In this embodiment, the alignment fixture **402** with alignment members **404** and **406** is substituted for the release card substrate layer **228** associated with the transdermal patch component **410**. The alignment fixture includes a silicone release coating on upper surface **402A** applied to the side to which the patch adheres prior to removal. This embodiment is assembled and applied in a similar manner to those described just above. Thus, the lid **424** of the drug pack is removed and the openings **414** and **416** are aligned with the members **404** and **406** and the fully aligned device is peeled away in the manner of FIG. 11C.

[0084] It will further be appreciated that the assembled device or patch to be applied to a user may be of any convenient size as from as small as about 1 cm×2 cm to about 15 cm×20 cm. The size can vary widely depending on the active agent administered and the condition to be treated.

[0085] This invention has been described herein in considerable detail in order to comply with the patent statutes and to provide those skilled in the art with the information needed to apply the novel principles and to construct and use embodiments of the example as required. However, it is to be understood that the invention can be carried out by specifically different devices and that various modifications can be accomplished without departing from the scope of the invention itself.

What is claimed is:

1. An iontophoretic drug delivery system for pre-use assembly comprising:

- (a) a drug pack component comprising one or more gel pads;
- (b) an iontophoresis patch component;
- (c) wherein said iontophoresis patch component is configured to align with one or more gel pads of said drug pack component in conductive relation in an assembled state; and
- (d) an alignment structure to assist in assembling said components, wherein when said alignment structure is selected from:
 - (1) a folding support structure associated with said drug pack component and said iontophoresis patch component, said folding support structure comprises a separator component configured to physically separate and protect said drug pack and iontophoresis patch components when said iontophoretic drug delivery system is present in a folded storage stage; and
 - (2) a guide element for separate consecutive alignment of said drug pack with iontophoresis patch component.

2. An iontophoretic drug delivery system as in claim 1 wherein said alignment structure comprises a multi-panel folding support structure associating said drug pack component, said iontophoresis patch component and said separator component.

3. An iontophoretic drug delivery system as in claim 2 wherein said drug pack component and said iontophoresis patch component are provided on separate conjoined panels of said folding support structure.

4. An iontophoretic drug delivery system as in claim 2 wherein said folding support structure assumes one folded configuration for storage and a different folded configuration for assembly of said system.

5. An iontophoretic drug delivery system as in claim 2 wherein said support structure comprises four conjoined folding panels.

6. An iontophoretic drug delivery system as in claim 1 wherein said drug pack component and said iontophoresis patch component are provided on separate support structures and wherein said alignment structure comprises a guide element associated with at least one of said support structures.

7. An iontophoretic drug delivery system as in claim 3 wherein said support structures are connected.

8. An iontophoretic drug delivery system as in claim 6 wherein said guide element includes raised alignment members and said support structures include corresponding openings to receive said alignment members.

9. An iontophoretic drug delivery system as in claim 5 wherein one of said support structures is attached to said guide element prior to assembly of said system.

10. An iontophoretic drug delivery system as in claim 1 wherein said drug pack component comprises gel pads

including an anode gel pad and a cathode gel pad isolated prior to assembly by a cover membrane having low moisture permeability.

11. An iontophoretic drug delivery system as in claim 10 wherein said gel pads comprise one or more layers of non-woven polymer matrix.

12. An iontophoretic drug delivery system as in claim 10 including an amount of therapeutic agent ion species located in gel associated with at least one of said gel pads.

13. An iontophoretic drug delivery system as in claim 1 including an amount of therapeutic species in said iontophoresis patch.

14. An iontophoretic drug delivery system as in claim 10 wherein said gel pads are fixed to a substrate layer in said drug pack by adherence of a gel material prior to assembly of said system.

15. An iontophoretic drug delivery system as in claim 12 wherein said therapeutic agent is present in said gel in a concentration from about 0.2% to 10%.

16. An iontophoretic drug delivery system as in claim 1 wherein said iontophoresis patch component includes electrodes comprising an anode and a cathode and a source of electric power.

17. An iontophoretic drug delivery system as in claim 16 wherein said drug pack component comprises gel pads and said electrodes are contained in recesses adapted to receive said gel pads of said drug pack upon assembly of said system into said assembled state.

18. An iontophoretic drug delivery system as in claim 1 further comprising a peripheral adhesive layer bonding said gel pads to said electrodes in said assembled state.

19. An iontophoretic drug delivery system as in claim 10 wherein said cover membrane having low moisture permeability comprises a material selected from the group consisting of metal/polymer composites and PVC.

20. An iontophoretic drug delivery system packaged for easy assembly comprising:

- (a) a drug pack component containing an anode gel pad and a cathode gel pad removably carried on a first support structure and isolated by a membrane having a low moisture permeability prior to assembly;
- (b) an iontophoresis patch component including an anode electrode and a cathode electrode and a source of electric power, said patch being removably carried on a second support structure;
- (c) wherein said iontophoresis patch component includes shaped recesses associate with said anode and said cathode configured to receive said anode and cathode gel pads respectively, in conductive relation in an assembled state;
- (d) wherein said first support structure and said second support structure are selected from the group consisting of conjoined folding panels including separator protector panels for folded storage and separate members for assembly with a guide element; and
- (e) and amount of therapeutic ion species located in at least one of said anode gel pad, said cathode gel pad and said iontophoresis patch.

21. An iontophoretic drug delivery system as in claim 20 further comprising a peripheral adhesive layer bonding said gel pads to said electrodes in said assembled state.

22. An iontophoretic drug delivery system comprising:

- (a) a drug pack component comprising one or more gel pads;

- (b) an iontophoretic patch component;
 - (c) an alignment structure to assist in assembling said components comprising a multi-panel folding support structure having a panel associated with each said drug pack component;
 - (d) wherein said iontophoresis patch component is configured to align with one or more gel pads of said drug pack component in conductive relation when said alignment structure is folded in an assembled state; and
 - (e) wherein said drug pack component and said iontophoresis patch component and separator panels are inside a folded structure and have a panel interposed therebetween as folded in a packaged or stored state.
- 23.** An iontophoretic drug delivery system as in claim **22** wherein a folded storage configuration is secured by a releasable adhesive.
- 24.** An iontophoretic drug delivery system as in claim **16** wherein said patch further comprises a half release liner covering a portion of a skin adhesive.
- 25.** A drug pack component for assembly into an iontophoretic drug delivery system comprising:
- (a) a carrier substrate;
 - (b) one or more gel pads adhered to said substrate;
 - (c) a cover membrane of a material of low moisture permeability spaced from and enclosing said one or more gel pads; and
 - (d) an amount of a gel material absorbed in said one or more gel pads with at least one of said pads containing an amount of a therapeutic agent.
- 26.** A drug pack as in claim **25** further comprising an occlusive ring on an exposed surface of each of said one or more gel pads.
- 27.** A drug pack as in claim **26** wherein said occlusive ring matches the periphery of a corresponding electrode.
- 28.** A drug pack as in claim **25** wherein said gel pads comprise laminated non-woven polymer matrices.
- 29.** A drug pack as in claim **28** wherein said matrices contain perforations.
- 30.** A drug pack as in claim **25** wherein the viscosity of said gel is at least 8,000 centipoises.
- 31.** A drug pack as in claim **25** wherein said gel material comprises a material selected from the group consisting of HPMC, PVP, PEO, and PVA and combinations thereof.
- 32.** A drug pack as in claim **31** wherein the viscosity of said gel is at least 8,000 centipoises.
- 33.** A drug pack as in claim **31** wherein said gel comprises HPMC.
- 34.** A drug pack as in claim **33** wherein the viscosity of said gel is at least 8,000 centipoises.
- 35.** A drug pack as in claim **25** wherein said gel pads include one or more materials selected from the group consisting of cotton, polypropylene, polyethylene and a polyester.
- 36.** A drug pack as in claim **35** wherein said gel pads include polypropylene.

- 37.** A drug pack as in claim **29** wherein said gel pads include polypropylene.
- 38.** A drug pack as in claim **35** wherein said gel pads comprise laminated, non-woven materials.
- 39.** A drug pack as in claim **25** wherein said cover membrane having low moisture permeability comprises a material selected from the group consisting of metal/polymer composites and PVC.
- 40.** A drug pack as in claim **39** wherein said cover membrane comprises an aluminum/nylon composite material.
- 41.** A method of assembling a drug pack comprising:
- (a) placing one or more gel pads in recesses in spaced cavities in a shaped lid member;
 - (b) dispensing an amount of gel onto each said one or more gel pads such that the height of the gel extends beyond the depth of each corresponding cavity;
 - (c) applying a generally flat carrier substrate layer to said lid member contacting the gel, and sealing the substrate layer to said lid member; and
 - (d) allowing said gel to cause each said gel pad to adhere to said substrate layer and be drawn away from a corresponding cavity as said gel is absorbed into each pad, providing a clearance between said cover membrane and said gel pads.
- 42.** A method as in claim **39** wherein step (c) is accomplished prior to said gel soaking through said pads.
- 43.** A method of storing an iontophoretic drug delivery system comprising:
- storing a drug pack component and an iontophoresis patch as separate entities in a common package for assembly prior to use wherein said drug pack component and said iontophoresis patch are configured to combine when superimposed to form a self-contained wearable drug delivery system.
- 44.** A method of using a prepackaged iontophoresis drug delivery system including drug pack and iontophoresis patch comprising:
- (a) removing the system drug pack and iontophoresis components from a storage package and removing necessary cover membranes and release liners;
 - (b) assembling the system by combining said drug pack and said iontophoresis using an alignment structure in a manner that brings them into permanent adhesive contact forming a transdermal iontophoresis patch that is ready to use; and
 - (c) applying the transdermal iontophoresis patch to the skin of a patient at a desired location.
- 45.** A method as in claim **44** wherein step (b) includes the use of a guide element.
- 46.** A method as in claim **44** wherein about one half of the patch skin adhesive layer is exposed initially when the patch is applied to the skin followed by removal of a half release liner to achieve full patch adhesion.

* * * * *