



US 20120075788A1

(19) **United States**

(12) **Patent Application Publication**  
**Moscovitch**

(10) **Pub. No.: US 2012/0075788 A1**

(43) **Pub. Date: Mar. 29, 2012**

(54) **UNIVERSAL QUICK CONNECTOR  
APPARATUS FOR AN LCD MONITOR**

filed as application No. PCT/IB00/01148 on Aug. 22, 2000.

(76) Inventor: **Jerry Moscovitch, Toronto (CA)**

(60) Provisional application No. 60/150,307, filed on Aug. 23, 1999.

(21) Appl. No.: **13/309,175**

**Publication Classification**

(22) Filed: **Dec. 1, 2011**

(51) **Int. Cl.**  
**G06F 1/16** (2006.01)

(52) **U.S. Cl.** ..... **361/679.21**

(57) **ABSTRACT**

**Related U.S. Application Data**

(63) Continuation of application No. 13/182,148, filed on Jul. 13, 2011, now abandoned, which is a continuation of application No. 12/549,628, filed on Aug. 28, 2009, now abandoned, which is a continuation of application No. 12/042,015, filed on Mar. 4, 2008, now Pat. No. 7,594,823, which is a continuation of application No. 10/764,572, filed on Jan. 27, 2004, now Pat. No. 7,390,211, which is a continuation of application No. 10/069,151, filed on Jun. 20, 2002, now Pat. No. 6,702,604,

Described herein is a system having an LCD computer monitor including a monitor housing. The system further includes a connector apparatus for allowing quick electrical and mechanical coupling and decoupling of said LCD computer monitor to a support member disposed on a wall or a rear portion of a car seat. The connector apparatus has a first component attached to the rear surface of said LCD computer monitor and a second component mountable to the support member and capable of mating with the first component.

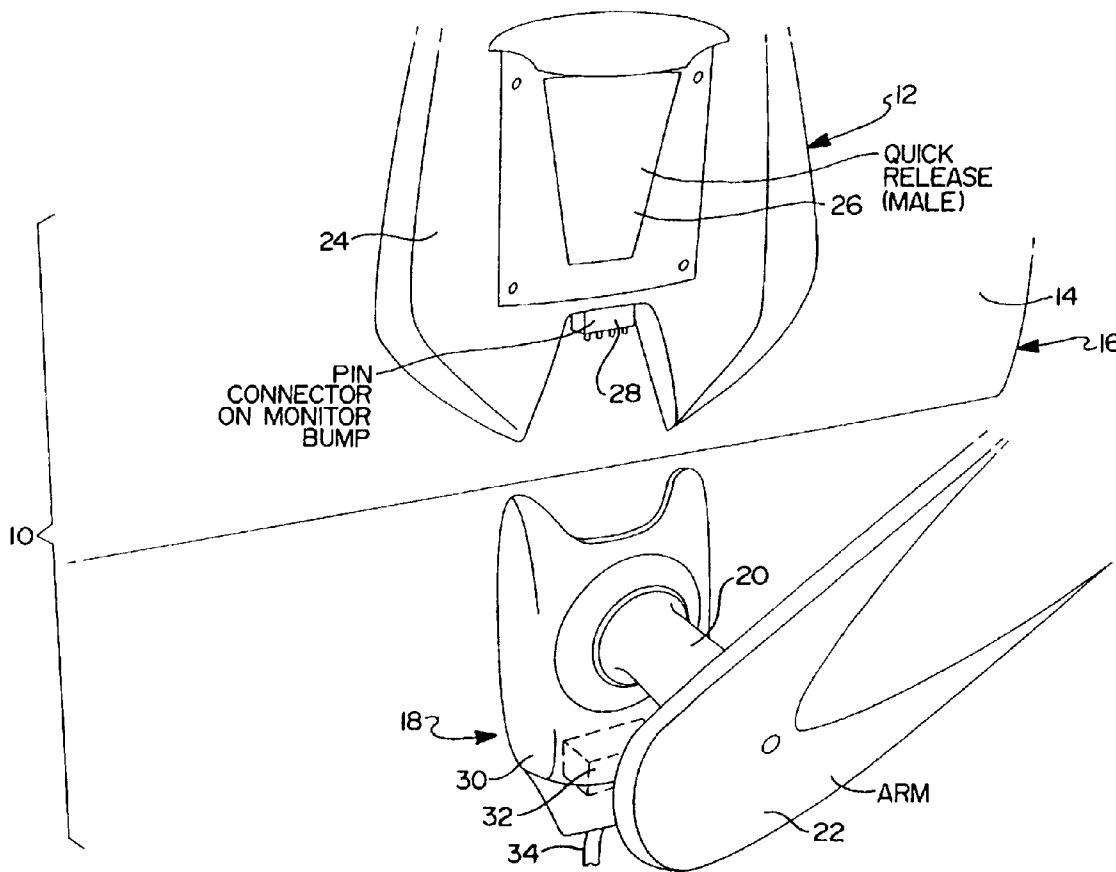

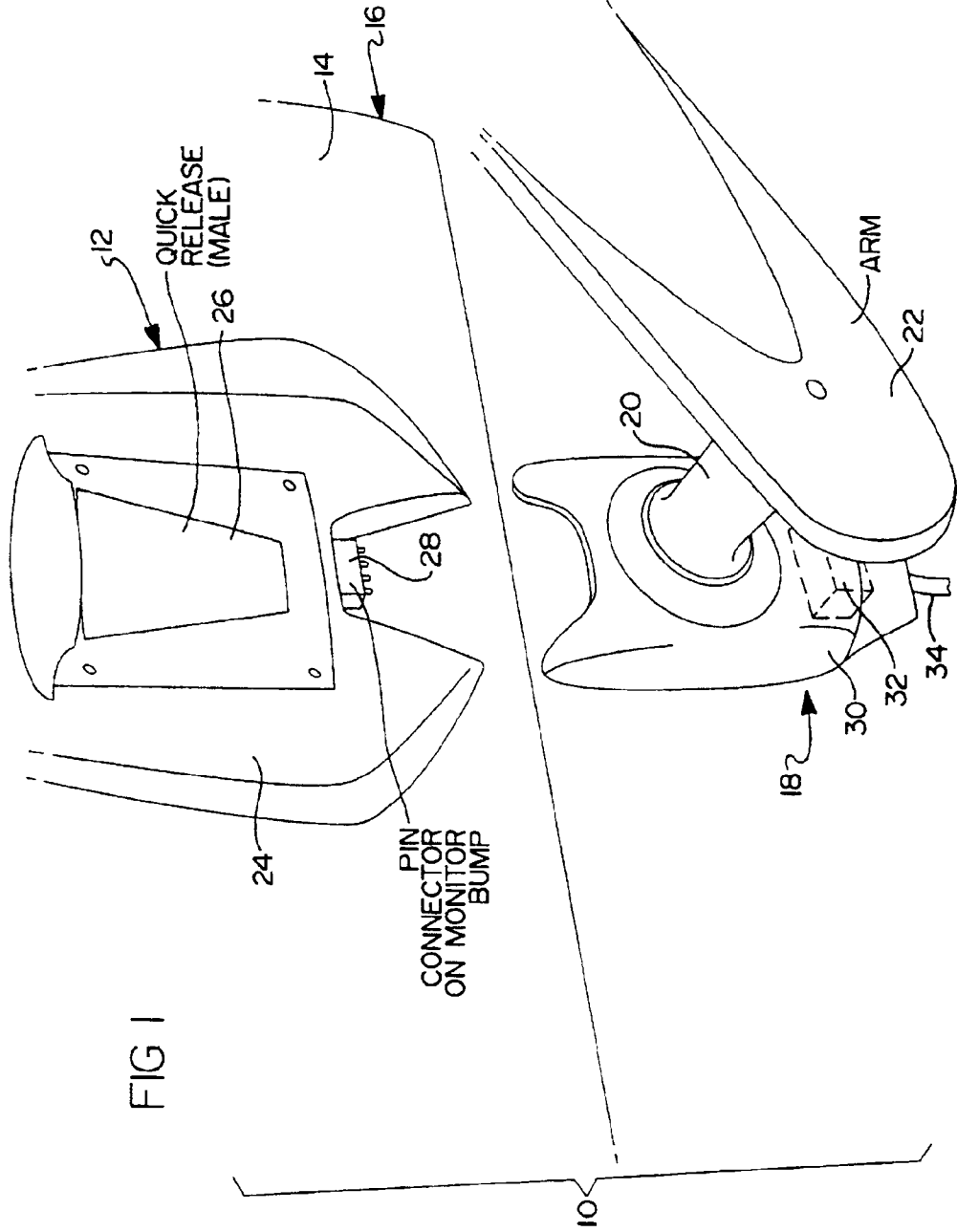
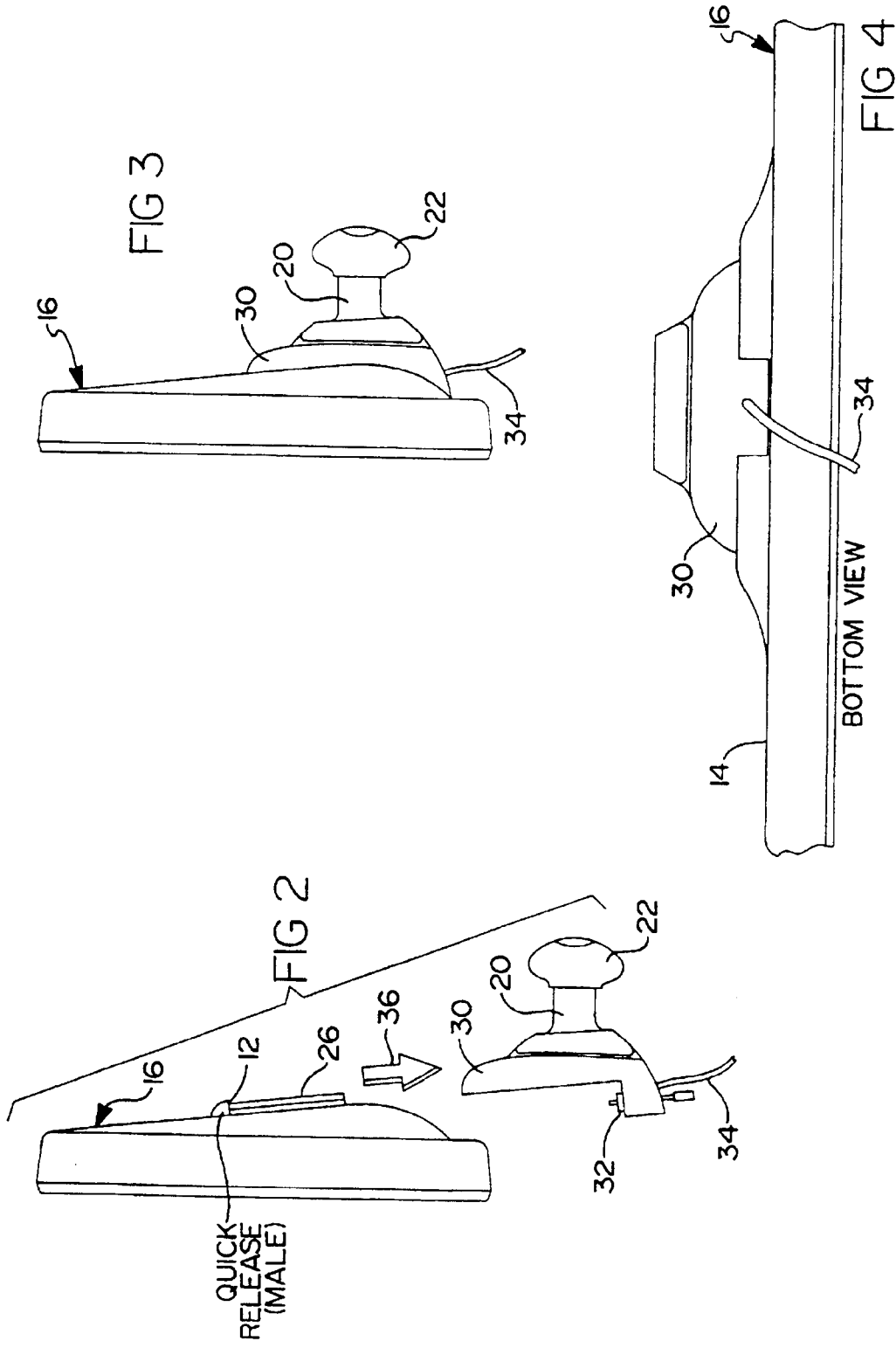
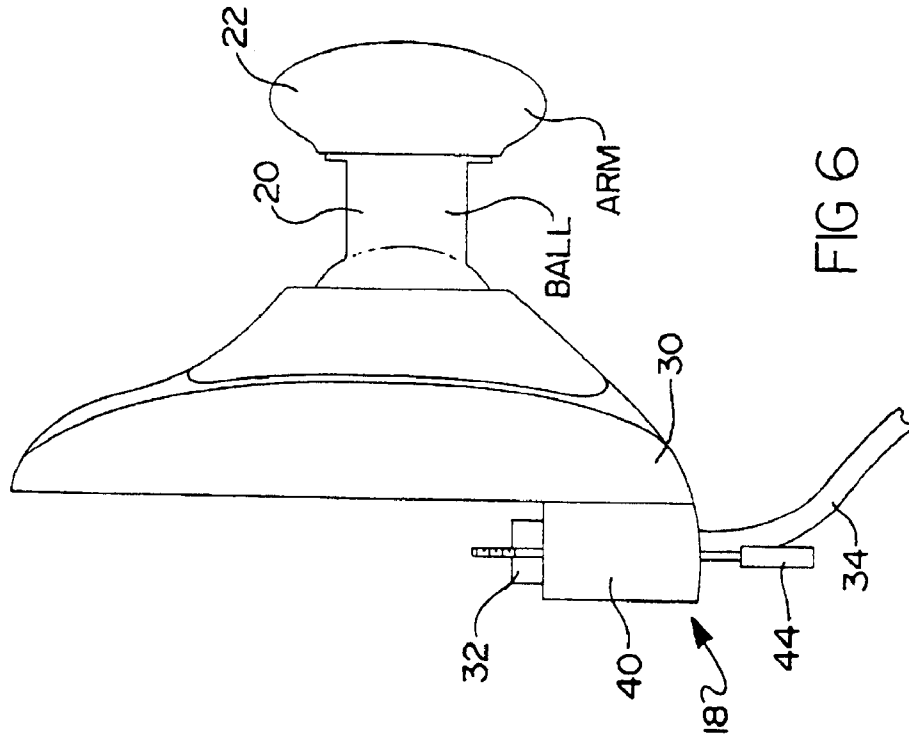
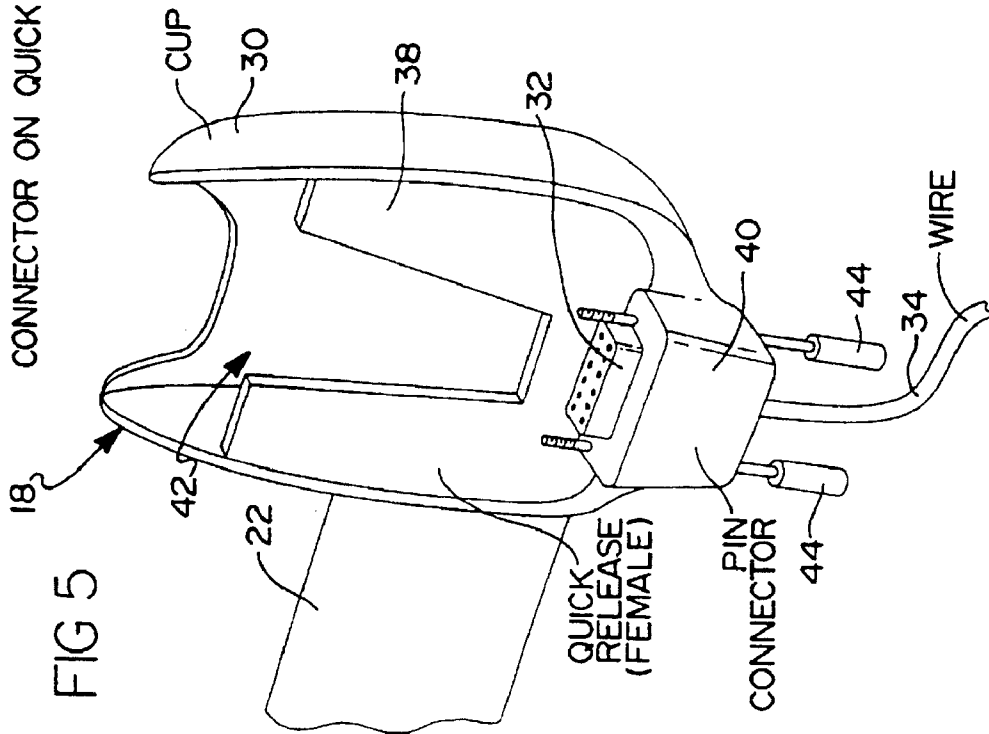
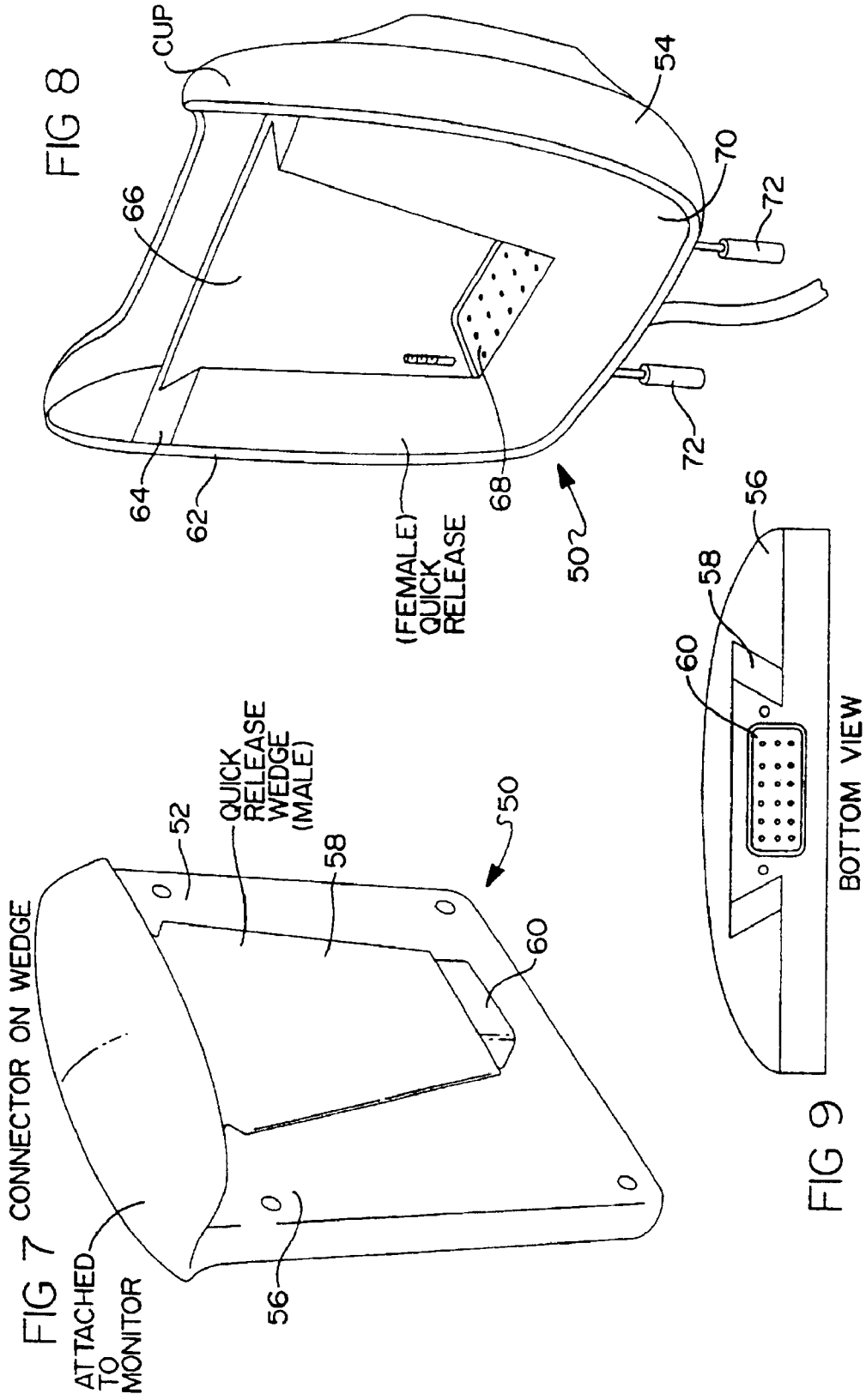

FIG 1



CONNECTOR ON QUICK RELEASE CUP





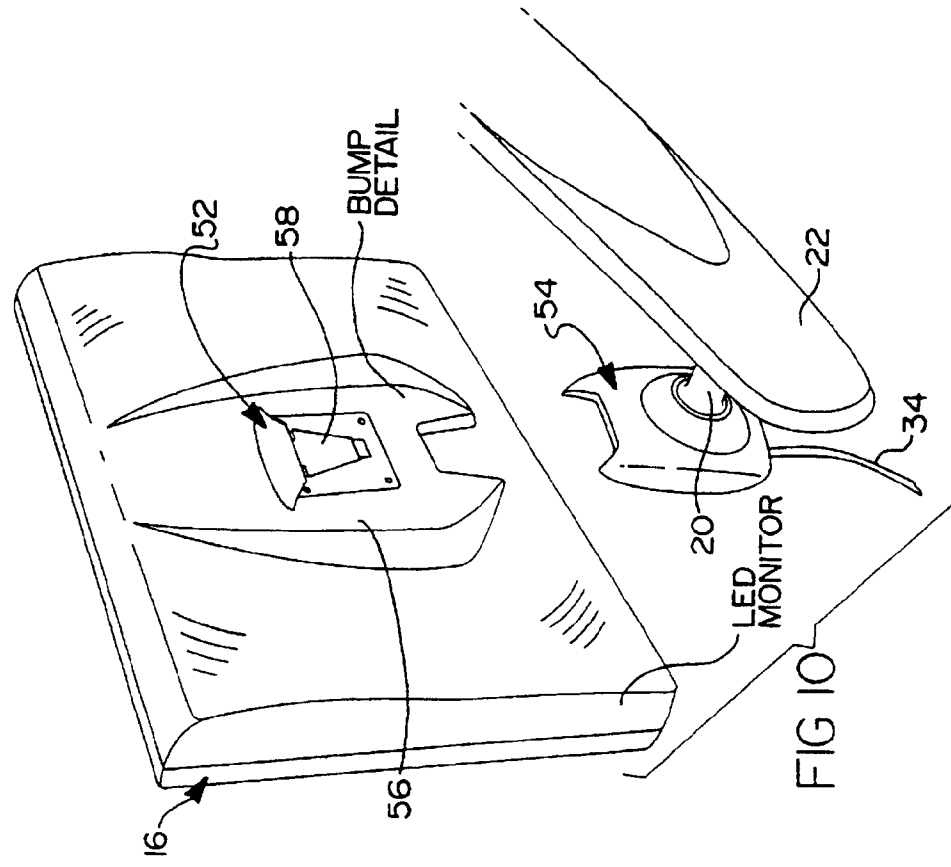
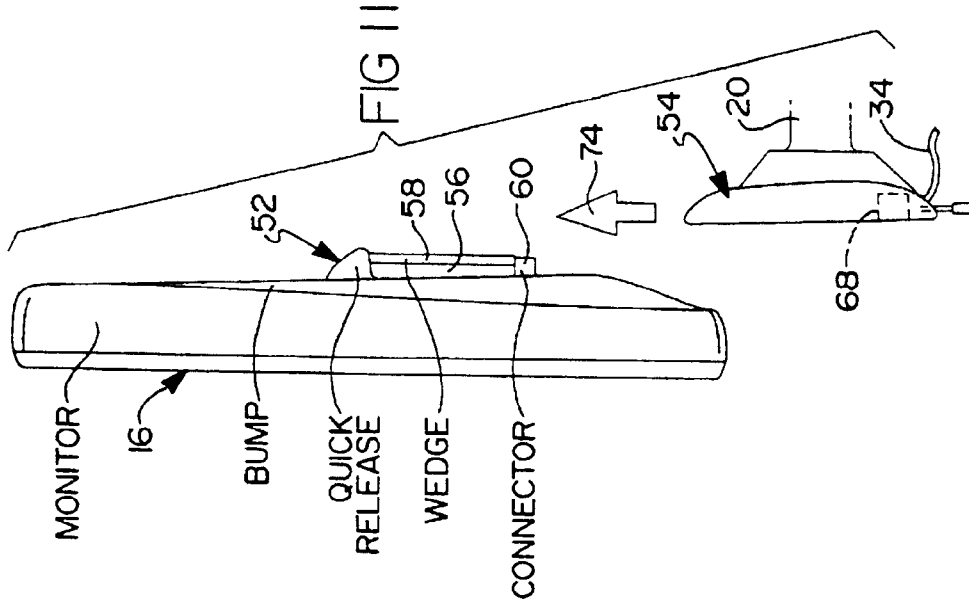

FIG 11

FIG 10

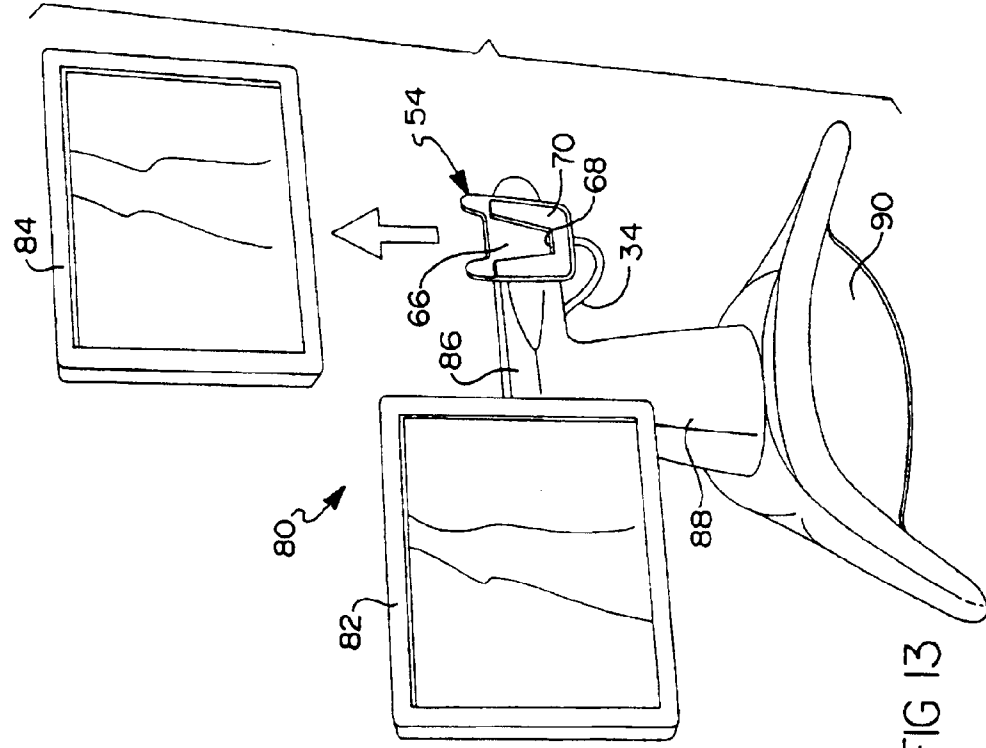

FIG 12

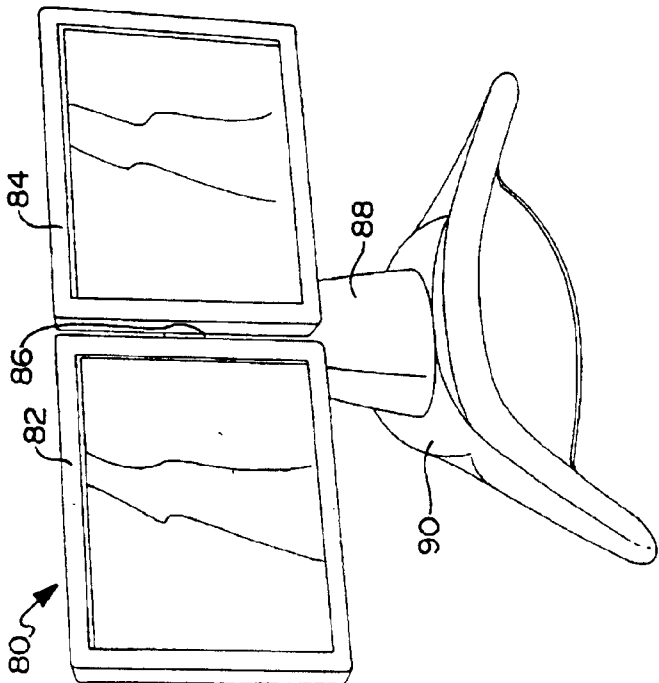
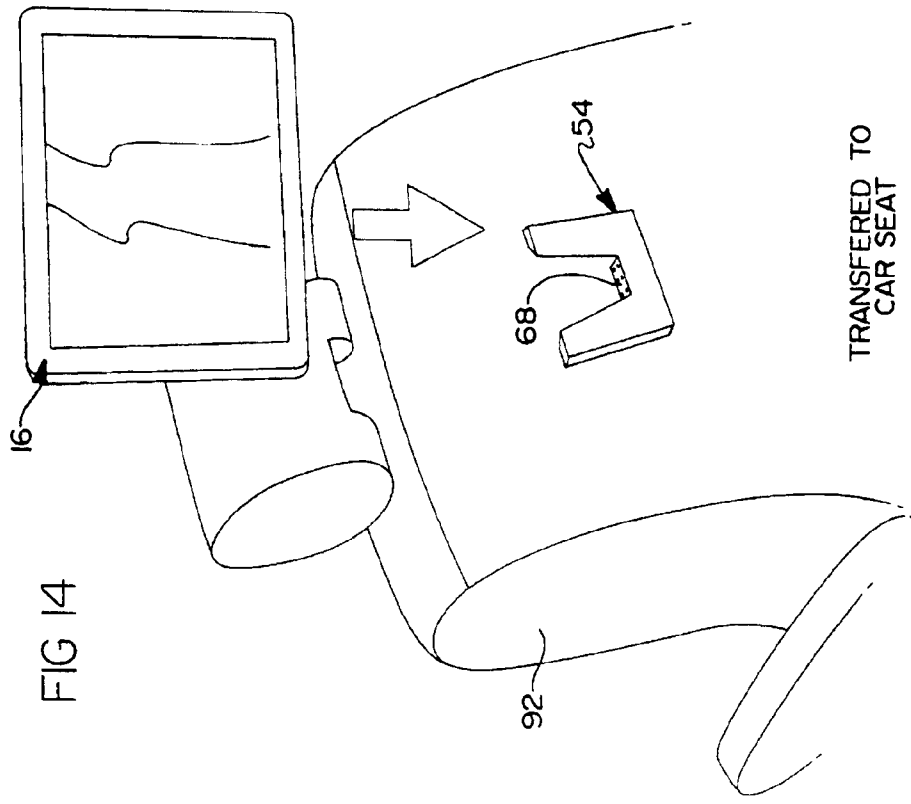
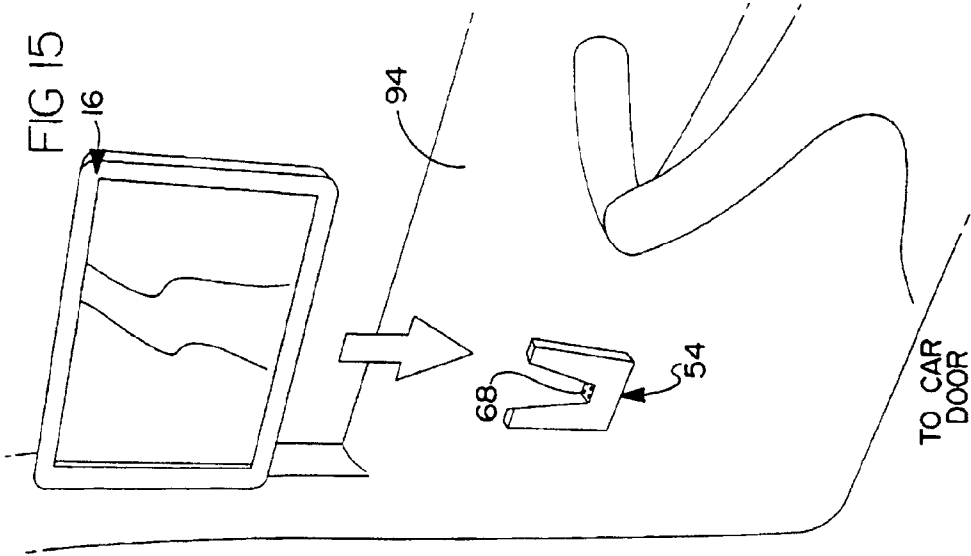
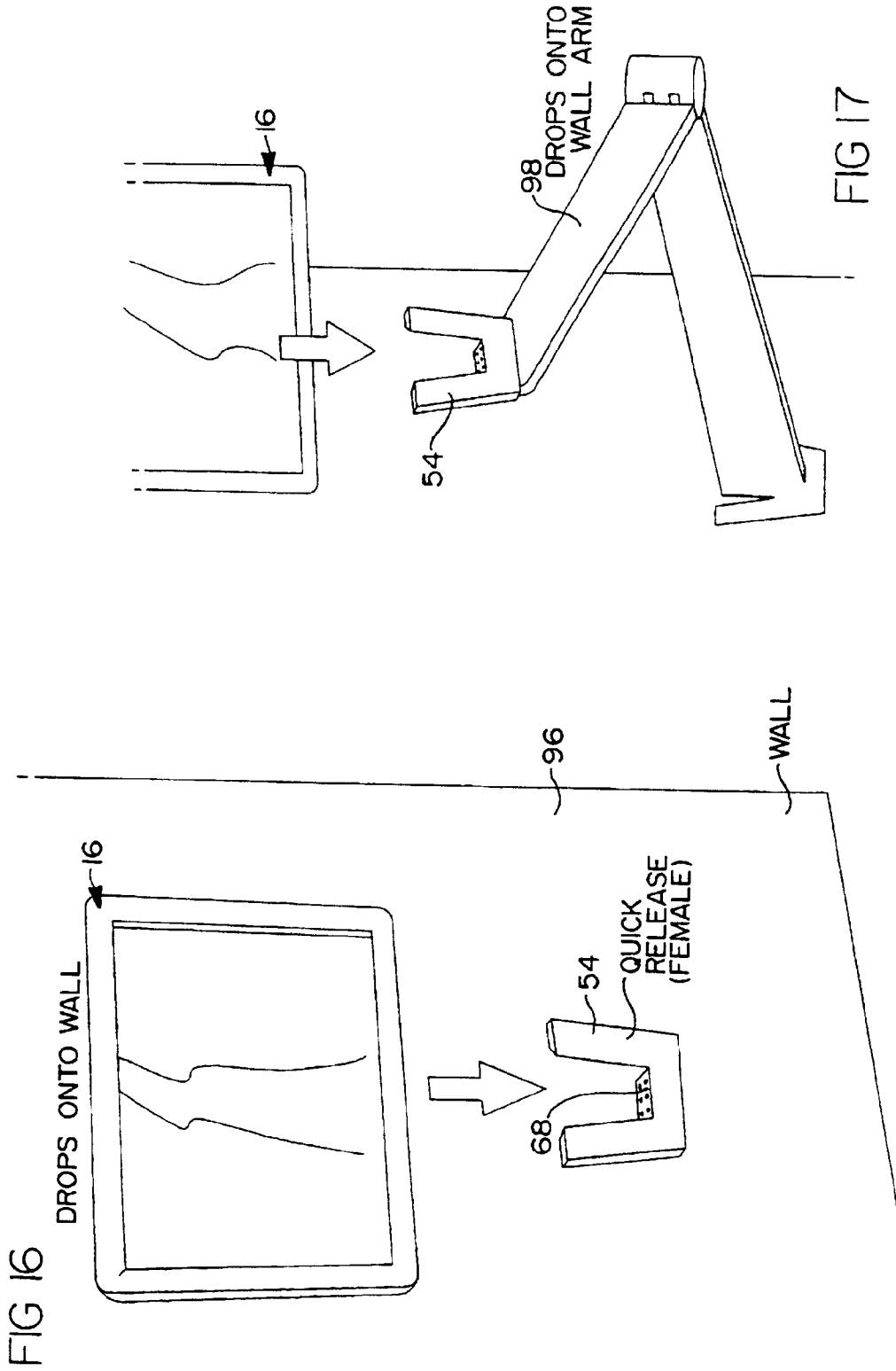

FIG 13







**UNIVERSAL QUICK CONNECTOR APPARATUS FOR AN LCD MONITOR**

**CROSS-REFERENCE TO RELATED APPLICATIONS**

[0001] This application is a continuation (CON) of and claims priority from U.S. application Ser. No. 13/182,148, which is a CON of and claims priority to U.S. application Ser. No. 12/549,628, filed Aug. 28, 2009, which is a CON of and claims priority from U.S. application Ser. No. 12/042,015, filed Mar. 4, 2008, which is a CON of and claims priority from U.S. application Ser. No. 10/764,572, filed Jan. 27, 2004, which is a CON of and claims priority from U.S. application Ser. No. 10/069,151, filed Jun. 20, 2002, which is a national stage application of PCT/IB00/01148, filed Aug. 22, 2000, which claims priority from U.S. Provisional Application No. 60/150,307, filed on Aug. 23, 1999.

**FIELD OF THE INVENTION**

[0002] This invention relates to LCD systems, and more particularly to an LCD display system which incorporates a quick connect/release connector apparatus for enabling an LCD monitor to be electrically and mechanically coupled, simultaneously, to a support member, through a quick and easy sliding movement of the LCD monitor.

**BACKGROUND OF THE INVENTION**

[0003] LCD monitors have become increasingly popular in a wide variety of applications. Such monitors are lightweight, when compared to CRT type monitors, and therefore much more easily handled by an individual. LCD monitors are often used in applications where two or more monitors are often required, such as in the financial industry, where multiple graphs of information need to be viewed in real time. Multiple monitor applications are also found in use in engineering applications, manufacturing applications, and a wide variety of other applications where a large amount of information needs to be displayed simultaneously for the user(s).

[0004] Often such multiple LCD monitor systems are supported on a common arm. The arm is typically held above the worksurface, such as a desk or table, by a vertical column attached to a base. Frequently the need arises to remove one LCD monitor and use it with a separate workstation area. Since LCD monitors are still relatively expensive as compared with CRT monitors, and further attached to a display stand to form a single assembly, it is not possible to easily remove one LCD monitor from a display system and connect it to another workstation where the need for the LCD monitor is more acute. Thus, it is either not possible or highly impractical to disconnect LCD monitors from various work areas and reconnect them at workstations where a particularly acute need for the additional monitor has arisen. The operation of electrically disconnecting the video cable from the LCD monitor, and then mechanically uncoupling the LCD from its support or base (if such was even provided for by the manufacturer of the display system), and then reconnecting the LCD monitor both electrically and mechanically to a different LCD display system and associated computer, would be extremely time consuming and cumbersome.

[0005] The lack of a present day means to conveniently electrically and mechanically mount an LCD monitor, removably, on some form of a cooperating docking station thus significantly limits the utility of the monitor by prevent-

ing it from being easily removed from use in one application and physically taken by the user to be used in another application. For example, the lack of such a coupling/connector system prevents an LCD monitor used with a computer at a user's workplace from being easily uncoupled and taken home for use with a home computer. Providing a connector system which would allow quick and easy electrical and mechanically coupling and uncoupling of the LCD monitor would allow it to be easily taken by the user and used wherever it may be needed.

[0006] Accordingly, it is a principal object of the present invention to provide a universal connector apparatus which enables an electrical and mechanical connection to be made, generally simultaneously, between an LCD monitor and a docking station of a supporting member, thus allowing the LCD monitor to be used,

[0007] It is a further object of the present invention to provide a connector apparatus for an LCD monitor which is relatively inexpensive to produce, lightweight, compact and which does not require any special tools such as screwdrivers, pliers, etc., to enable an LCD monitor to be uncoupled, both electrically and mechanically, from a support member.

[0008] It is still a further object of the present invention to provide a universal connector apparatus which enables two or more LCD monitors, each having one portion of the connector apparatus, to be electrically and mechanically coupled, and interchanged as needed, to one or more second portions of the connector apparatus. In this manner any number of LCD monitors could be coupled or interchanged as needed to a support member or docking station without any modification to the LCD monitor or the support member/docking station.

**SUMMARY OF THE INVENTION**

[0009] The present invention relates to a universal connector apparatus having a first component and a second component. The first component is intended to be fixedly secured to an LCD monitor on an exterior surface thereof, and preferably on a rear or bottom portion of a housing thereof. The second component is a mating component which is intended to be fixedly secured to any form of support member or surface. The first member comprises a housing having an electrical connector, preferably a male connector. The second member comprises a housing in the form of a cup which has a mating electrical connector, and preferably a female connector, fixedly mounted therein.

[0010] The housing of the first component further includes an integrally formed protrusion which, in one embodiment, comprises a wedge shaped protrusion. The housing of the second component comprises a recess which is shaped complementarily to the projection on the first component of the connector assembly. Accordingly, when a wedge shaped protrusion is employed, then a similarly sized wedge shaped recess will be employed in the housing of the second component.

[0011] The electrical connector component mounted within the housing of the second component is preferably mounted at the bottom of the recess. When the projection of the first component is slidably inserted into the recess of the second component, both a mechanical and an electrical connection are made almost simultaneously. If a wedge shaped projection and recess is employed, the wedge shape provides

the added benefit of automatically aligning the male and female electrical connectors as they are slid into mating engagement with one another.

[0012] It will be appreciated that the two piece connector apparatus described above can be used in a wide variety of applications, such as within vehicles, on wall mounted monitor support arms, directly on walls, or wherever desired. The only limitation is that the surface that the second component is attached to has sufficient area and strength to allow the second component to be fixedly attached to it.

#### BRIEF DESCRIPTION OF THE DRAWINGS

[0013] The various advantages of the present invention will become apparent to one skilled in the art by reading the following specification and by referencing the following drawings, in which;

[0014] FIG. 1 is a perspective view of a portion of a rear area of an LCD monitor incorporating a preferred embodiment of a first component of the universal connector apparatus, and a portion of a support arm incorporating a preferred embodiment of a second component of the apparatus, with the two components about to be slidably engaged with one another;

[0015] FIG. 2 is a side view of the LCD monitor of FIG. 1 about to be slidably engaged with the support arm through the use of the two connector components;

[0016] FIG. 3 is a side view of the LCD monitor and support arm of FIG. 2 coupled together through the use of the connector apparatus;

[0017] FIG. 4 is a bottom view of the LCD monitor and support arm of FIG. 3 illustrating the slim-line profile of the coupled components;

[0018] FIG. 5 is a perspective view of the second component of the connector apparatus;

[0019] FIG. 6 is a side view of the second component coupled to a ball joint associated with a horizontal support arm of a display base;

[0020] FIG. 7 is a perspective view of an alternative preferred embodiment of the first component of the connector apparatus;

[0021] FIG. 8 is a perspective view of a mating second component for the first component shown in FIG. 7;

[0022] FIG. 9 is a bottom view of the first component shown in FIG. 7;

[0023] FIG. 10 is a perspective view of the first component of FIG. 7 attached to a rear area of a housing of an LCD monitor, and ready to be slidably coupled to the second component of FIG. 8, which is in turn coupled to a support arm;

[0024] FIG. 11 is a side view of the system shown in FIG. 10;

[0025] FIG. 12 is a perspective view of two LCD monitors being supported on a support member, where at least the right LCD is coupled to the support arm through the use of one of the embodiments of the connector apparatus of the present invention;

[0026] FIG. 13 shows the display system of FIG. 11 with the right monitor uncoupled from the support arm;

[0027] FIG. 14 shows an alternative application of the connector apparatus of the present invention being used to releasably couple an LCD monitor to the rear of a vehicle seat;

[0028] FIG. 15 shows another alternative application where an LCD monitor is releasably coupled to an inside of a vehicle door;

[0029] FIG. 16 is a perspective view of an LCD monitor about to be supported on a vertical wall through the use of the connector apparatus of the present invention; and

[0030] FIG. 17 is a perspective view of an LCD monitor about to be releasably coupled to a pivoting display arm attached to a wall surface.

#### DETAILED DESCRIPTION OF THE PREFERRED EMBODIMENTS

[0031] Referring to FIG. 1, there is shown a connector apparatus 10 in accordance with a preferred embodiment of the present invention. The connector apparatus 10 includes a first component 12 which is fixedly attached to a housing 14 of a liquid crystal display (LCD) monitor 16. The first connector 12 is preferably attached to a rear or bottom surface of the housing 14, but it will be appreciated that the first component 12 could be secured at other locations on the housing provided sufficient area is available to attach the component 12. A second connector component 18 forms a docking station and is attached, in this embodiment, to a ball joint 20, which is in turn attached to a support arm 22. The ball joint 20 allows the second component 18 to be moved as needed relative to the support arm 22 and, therefore, to allow the LCD monitor 16 to be adjusted for an optimum viewing angle.

[0032] With further reference to FIG. 1, the first component 12 includes a housing 24 having a wedge shaped protrusion 26. Below the wedge shaped protrusion is an electrical connector 28 which, in this embodiment, is illustrated as a male connector. The second component 18 includes a cup shaped housing 30 within which is disposed a second electrical connector 32. A video cable 34 is electrically coupled to the electrical connector 32. In this embodiment, the electrical connector 32 comprises a female connector. It will be appreciated, however, that the electrical connector 28 of the first component 12 could be a female component and the connector 32 could be a male component.

[0033] Referring to FIG. 2, the LCD monitor 16 is shown about to be attached to the second component 18 of the connector apparatus 10. Arrow 36 indicates that the LCD monitor 16 is moved slidably down onto the cup shaped housing 30 to attach the first component 12 to the second component 18 of the connector apparatus 10. The inter coupled components 12 and 18 are illustrated in FIG. 3. When attached as shown in FIG. 3, the first component 12 is disposed generally within the cup shaped housing 30 and electrically and mechanically coupled to the second component 18. Second component 18 thus not only allows an electrical connection to be made with the video cable 34, but also has sufficient strength to support the entire LCD monitor 16. The attached components are also shown in FIG. 4 from a bottom view. FIG. 4 illustrates the generally blended, low profile attachment of the first and second components 12 and 18, respectively.

[0034] Referring now to FIG. 5, the second component 18 can be seen in greater detail. The cup shaped housing 30 has a wedge component 38 adjacent to a lower housing portion 40 within which the female electrical connector 32 is disposed. A recessed area 42 behind the wedge component 38 provides a small amount of clearance for a portion of the wedge member 26 when member 26 is inserted into the second component 18. The interengagement of the wedge shaped portion 26 and the wedge shaped member 38 serves to automatically align the male pins of electrical connector 28 (FIG. 1) with the electrical connector 32 when the first component 12 is slid-

ably attached to the second component **18**. Threaded screws **44** can then be used to even more positively secure the two electrical connectors **28** and **32** to one another. The generally low profile arrangement of the second connector **18** is shown further in FIG. 6.

[0035] The connector apparatus **10** of the present invention thus enables the LCD monitor **16** to be slidably coupled to a support arm **22** such that the entire LCD monitor **16** can be supported securely. The intercoupling of the first and second components **12** and **18**, respectively, does not require time consuming disassembly or any special tools. When it is desired to remove the monitor **16** from the cup shaped housing **30** of the second component **18**, the user merely lifts the LCD monitor **16** upwardly and the entire unit will slidably disengage from the electrical connector **32** (provided threaded screws **44** are not engaged with connector **28**). The wedge shaped components **26** and **38** further ensure that the electrical connectors **28** and **32** will be perfectly aligned every time the LCD monitor **16** is secured to the second component **18**.

[0036] Referring now to FIGS. 7 and 8, a connector apparatus **50** in accordance with an alternative preferred embodiment of the present invention is shown. The connector apparatus **50** generally comprises a first component **52** and a second component **54**. The first component **52** is intended to be secured fixedly to a housing portion of an LCD monitor, just as shown in FIG. 1. The second component **54** is similarly intended to be fixedly secured to any other form of support member which is used to support the LCD monitor attached to the first component **52**. The first component **52** similarly includes a housing **56** with a wedge shaped protrusion **58** projecting therefrom. An electrical connector **60**, in this embodiment a male connector, is secured to the housing **56** at the bottom of the wedge shaped protrusion **58**. The orientation of the electrical connector **60** is shown in FIG. 9.

[0037] Referring to FIG. 8, the second component **54** is shown in greater detail. The second component **54** includes a cup shaped housing **62** having a component **64** forming a wedge shaped recess **66**. An electrical connector **68** is disposed within a lower portion **70** of the wedge shaped member **64**. Threaded screws **72** may be included or used with the connector **68** to help secure the connector **68** to the connector **60**.

[0038] Securing of the first component **52** to the second component **54** is otherwise identical to the connector apparatus **10**. The LCD monitor attached to the first component **52** is positioned adjacent the second component **54** and then lowered such that the wedge shaped protrusion **58** slidably engages within the wedge shaped recess **66**. The wedge shaped recess **66** serves to automatically center and align the connector **60** with the connector **68** as the first component **52** fully slidably engages the second component **54**.

[0039] With both of the embodiments **10** and **50** of the present invention, it will be appreciated that electrical connectors **28** and **60**, respectively, are each electrically coupled to the display element of the LCD monitor to which they are secured. Thus, one side of each of connectors **28** and **60** will have electrical conductors in communication with the display element. Each of the first components **12** and **52** may be attached to a housing of an LCD monitor by threaded screws or any other means which securely affixes the body of the component **12** or **52** to a portion of the housing of the LCD

monitor. Alternatively, it may be advantageous to form the first components **12** or **52** with the housing of the LCD monitor.

[0040] Referring now to FIGS. 10 and 11, the sliding attachment of the first component **52** with the second component can be seen. The first component **52** is shown attached to the LCD monitor **16**. Arrow **74** in FIG. 11 indicates the direction of movement of the second component **54** relative to the first component **52** in order to effect attachment of the two components together.

[0041] Referring now to FIG. 12, a dual screen LCD monitor system **80** is shown incorporating LCD monitors **82** and **84**. LCD monitors **82** and **84** are supported on a generally horizontally disposed arm **86**, which is in turn supported on a generally vertically disposed column **88**. The column **88** is in turn supported on a base **90**. In FIG. 13, it can be seen how LCD monitor **84** can be lifted off of the second component **54** by lifting upwardly on the LCD monitor **84**.

[0042] In FIG. 14, it can be seen how the second component **54** can be modified to omit the cup shaped housing **62** and could be attached to a seat **92** within a vehicle to allow LCD monitor **16** to be releasably detached from the second component **54** and removed from the vehicle. FIG. 15 similarly shows the second component **54** attached to an inside of a vehicle door **94** which allows the LCD monitor **16** to be removed from its location on a vehicle door and taken from the vehicle.

[0043] Referring now to FIG. 16, the second component **54** is shown attached to a wall **96**. The LCD monitor **16** can thus be supported on the wall **96** simply by dropping the monitor slidably onto the second component **54** such that the first and second components **52** and **54**, respectively, become slidably engaged. In FIG. 17, the second component **54** is shown secured to a pivotal support arm **98**, which is also attached to the wall **96**. The LCD monitor **16** can be attached to the second component **54** as described hereinbefore.

[0044] It will be appreciated then that the preferred embodiments of the present invention allow an LCD monitor to be quickly and easily coupled to and uncoupled from a support member without the need for complicated disassembly procedures. The wedge shaped portions of each of the first and second components of the present invention further enable the electrical connectors of the first and second components to be aligned precisely as the first component attached to the LCD monitor is slidably engaged with the second component. Thus, there is little or no chance that the user will damage the male pins of the male electrical connector during reattachment of the monitor to the second component.

[0045] It will further be appreciated that a principal advantage of the connector apparatus **10** or **50** of the present invention is that it allows one LCD monitor to be used at a variety of locations where the second component of the apparatus is in use. This provides much greater versatility for an LCD display monitor by allowing it to be used in a variety of environments where the need may arise.

[0046] Those skilled in the art can now appreciate from the foregoing description that the broad teachings of the present invention can be implemented in a variety of forms. Therefore, while this invention has been described in connection with particular examples thereof, the true scope of the invention should not be so limited since other modifications will become apparent to the skilled practitioner upon a study of the drawings, specification and following claims.

1. A system comprising:

- an LCD computer monitor having a monitor housing, the LCD computer monitor connected to a computer via an external video cable; and
- a connector apparatus for allowing quick electrical and mechanical coupling and decoupling of said LCD computer monitor to a support member disposed on a wall or a rear portion of a car seat, the connector apparatus having
  - a first component attached to the rear surface of said LCD computer monitor with four screws, said first component having a wedge-shaped protrusion and a first electrical connector having a plurality of pins disposed below the wedge-shaped protrusion;
  - a second component mountable to said support member disposed on the wall or the rear portion of the car seat, said second component having a wedge-shaped cavity and a second electrical connector having a plurality of holes for accepting the plurality of pins; and
  - a securing mechanism for securing the second component to the first component, the securing mechanism including two screw holes and two vertical threaded screws below and to either side of the plurality of holes, the two vertical threaded screws being screwed into the two screw holes by the user to secure the second component to the first component and being unscrewed by the user to disengage the second component from the first component, wherein a) said wedge-shaped protrusion and said wedge-shaped cavity have complementary shapes to allow the wedge-shaped protrusion to be inserted into the wedge-shaped cavity so that the support member physically supports said display screen, b) the wedge-shaped protrusion is allowed to be lowered onto the wedge-shaped cavity to mate therewith, and c) while said wedge-shaped protrusion is being inserted into said wedge-shaped cavity, the plurality of pins concurrently insert into the plurality of holes to cause electrical coupling of the first electrical connector and the second electrical connector.

2. A system comprising:

- an LCD computer monitor having a monitor housing, the LCD computer monitor substantially limited to displaying results of computer operations performed by a computer disposed outside the monitor housing and connected to the LCD computer monitor via an external video cable; and
- a connector apparatus for allowing quick electrical and mechanical coupling and decoupling of said LCD computer monitor to a support member disposed on a rear portion of a car seat, the connector apparatus having
  - a first component attached to the rear surface of said LCD computer monitor with four screws, said first component having a wedge-shaped protrusion and a first electrical connector having a plurality of pins disposed below the wedge-shaped protrusion;
  - a second component mountable to said support member disposed on the rear portion of the car seat, said second component having a wedge-shaped cavity and a second electrical connector having a plurality of holes for accepting the plurality of pins; and
  - a securing mechanism for securing the second component to the first component, the securing mechanism including two screw holes and two vertical threaded screws below and to either side of the plurality of holes, the two vertical threaded screws being screwed into the two screw holes by the user to secure the second component to the first component and being unscrewed by the user to disengage the second component from the first component, wherein a) said wedge-shaped protrusion and said wedge-shaped cavity have complementary shapes to allow the wedge-shaped protrusion to be inserted into the wedge-shaped cavity so that the support member physically supports said display screen, b) the wedge-shaped protrusion is allowed to be lowered onto the wedge-shaped cavity to mate therewith, and c) while said wedge-shaped protrusion is being inserted into said wedge-shaped cavity, the plurality of pins concurrently insert into the plurality of holes to cause electrical coupling of the first electrical connector and the second electrical connector.

\* \* \* \* \*