



(19) **United States**

(12) **Patent Application Publication**  
**FUJIOKA et al.**

(10) **Pub. No.: US 2013/0272840 A1**  
(43) **Pub. Date: Oct. 17, 2013**

(54) **COMPRESSED GAS SUPPLY UNIT,  
COMPRESSED GAS SUPPLY APPARATUS  
AND CONTROL METHOD OF SAID UNIT  
AND SAID APPARATUS**

(52) **U.S. Cl.**  
CPC ..... **F04D 27/00** (2013.01)  
USPC ..... **415/1; 415/118**

(71) Applicant: **ANEST IWATA CORPORATION,**  
Yokohama-shi (JP)

(57) **ABSTRACT**

(72) Inventors: **Tamotsu FUJIOKA,** Yokohama-shi  
(JP); **Atsushi UNAMI,** Yokohama-shi  
(JP); **Kenji MATSUZAKI,**  
Yokohama-shi (JP)

A compressed gas supply unit includes compressors. Gas discharged from the compressors is stored in a storage tank and then supplied to a gas recipient. The pressure of the storage tank, the operation temperature and the power consumption of each compressor, and the temperature around the compressors are sent to a controller and a monitoring device. A determination unit of the controller determines the presence or absence of the abnormality of the compressor from a difference between the operation temperature of the compressor and the temperature around the compressors. An effective load calculation unit calculates the effective load of each compressor from the power consumption of the compressor and the pressure of the storage tank. The controller controls the compressors based on the calculated effective load such that the loads of the compressors are equalized. An estimation unit estimates maintenance timing from the effective load.

(21) Appl. No.: **13/835,807**

(22) Filed: **Mar. 15, 2013**

(30) **Foreign Application Priority Data**

Mar. 30, 2012 (JP) ..... 2012-079612

**Publication Classification**

(51) **Int. Cl.**  
**F04D 27/00** (2006.01)

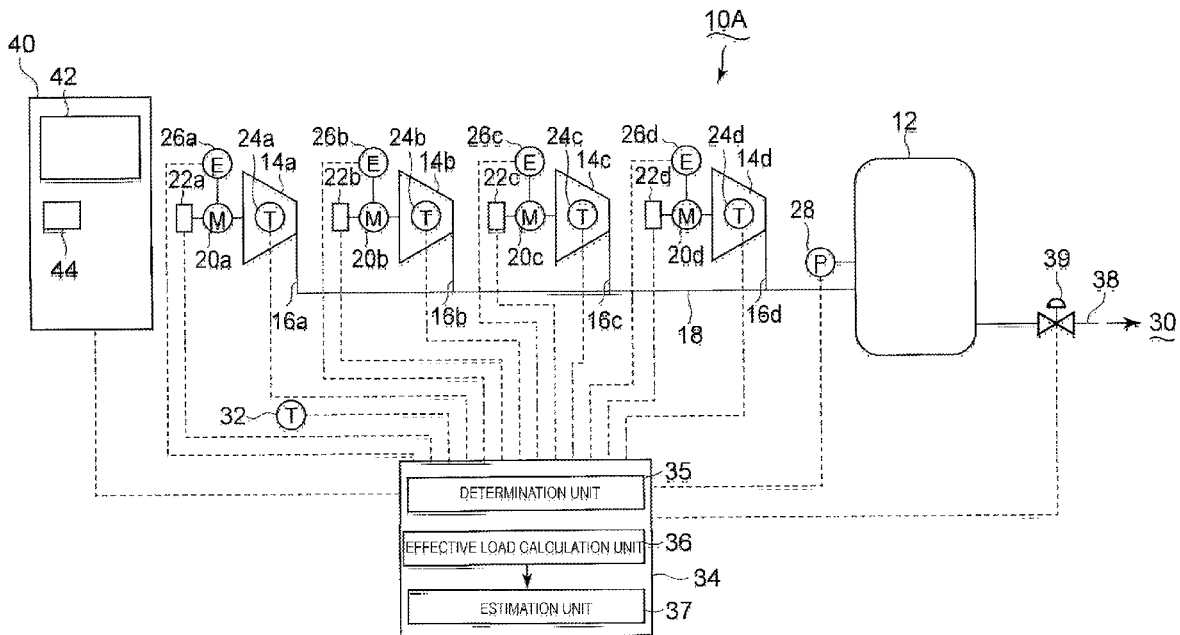
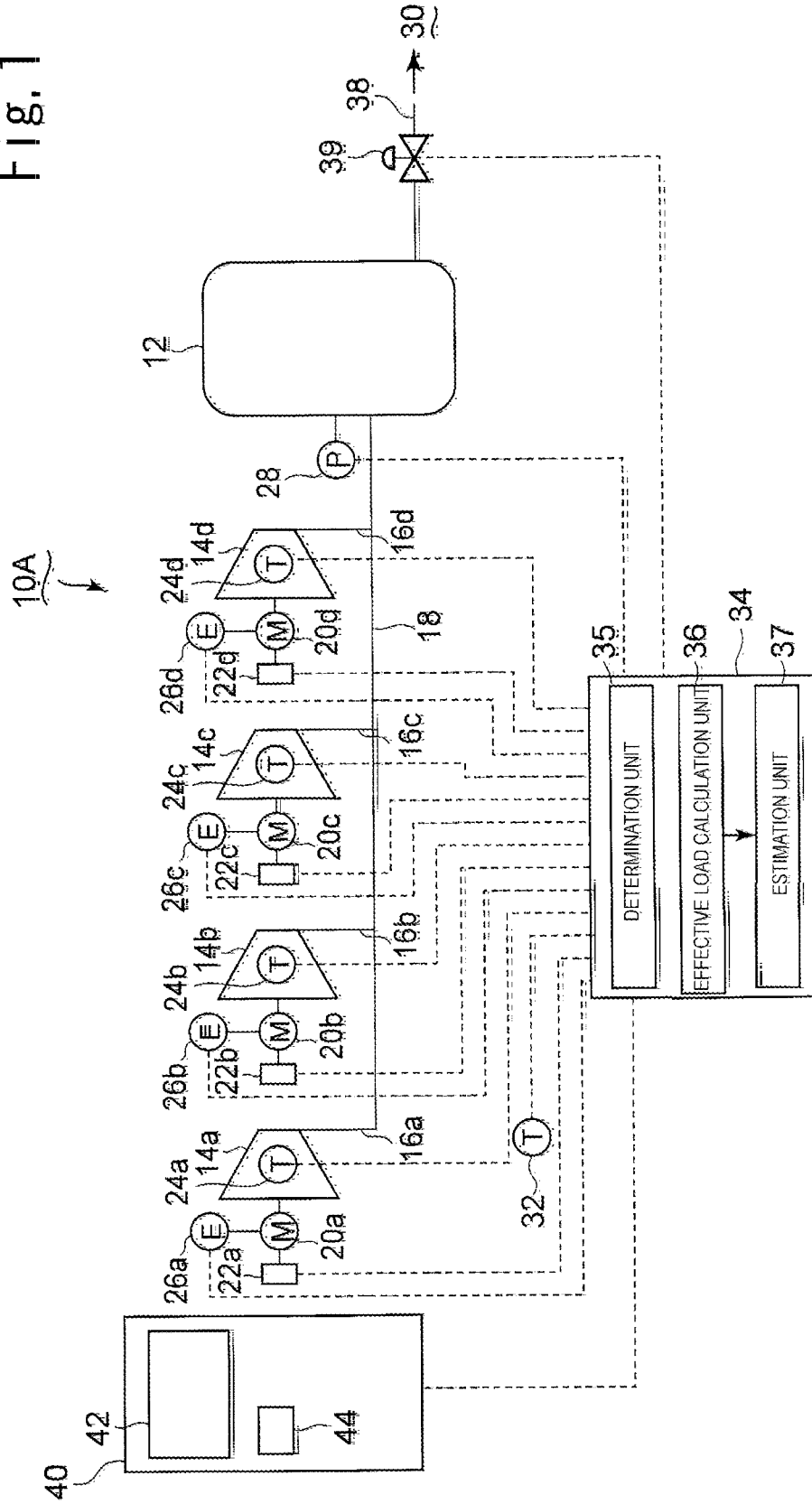
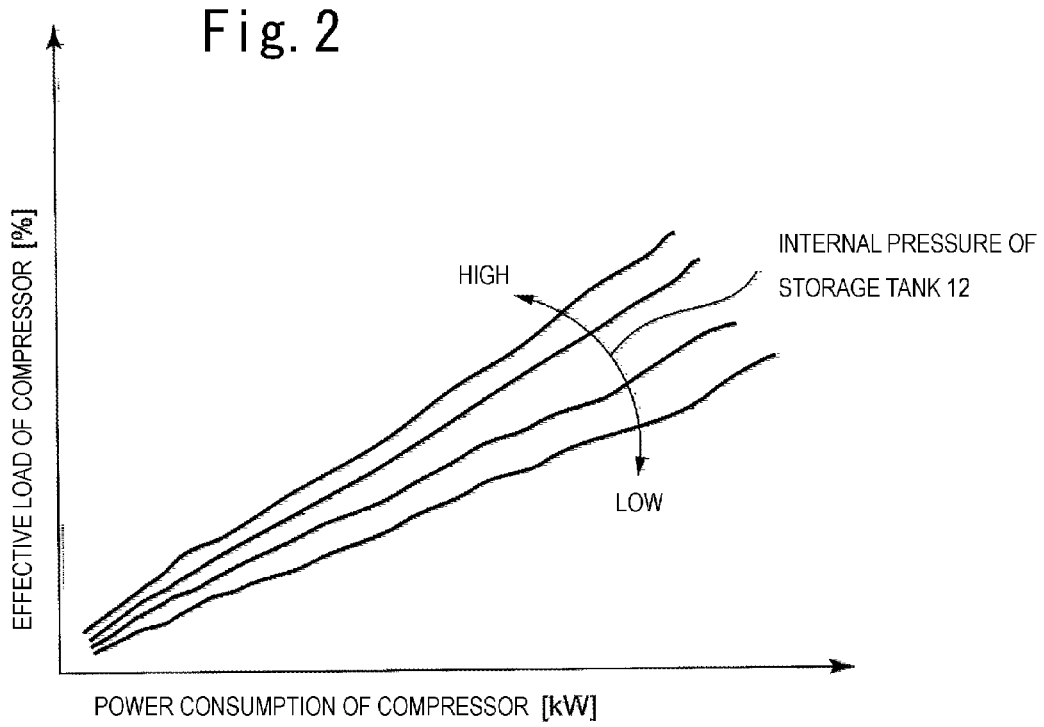

Fig. 1





**Fig. 3**

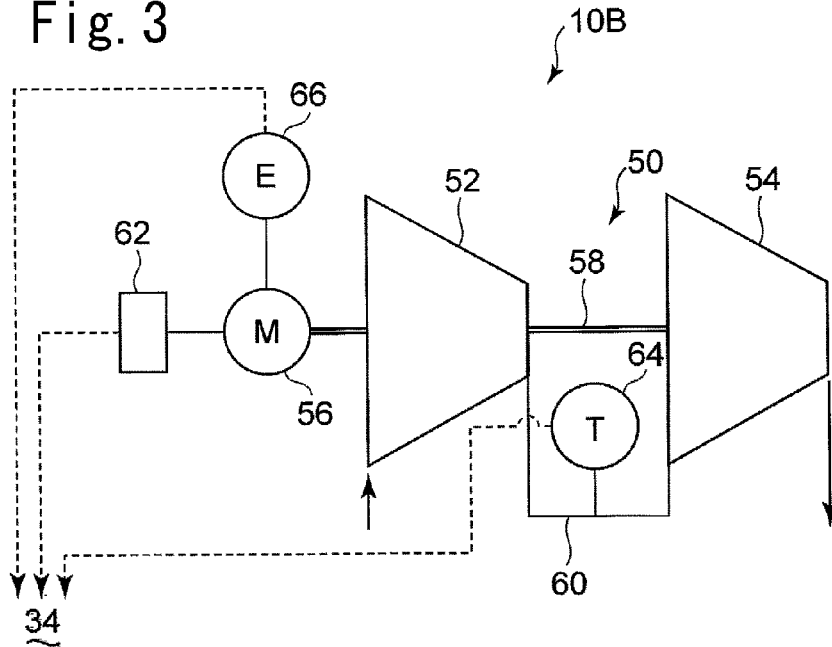

Fig. 4

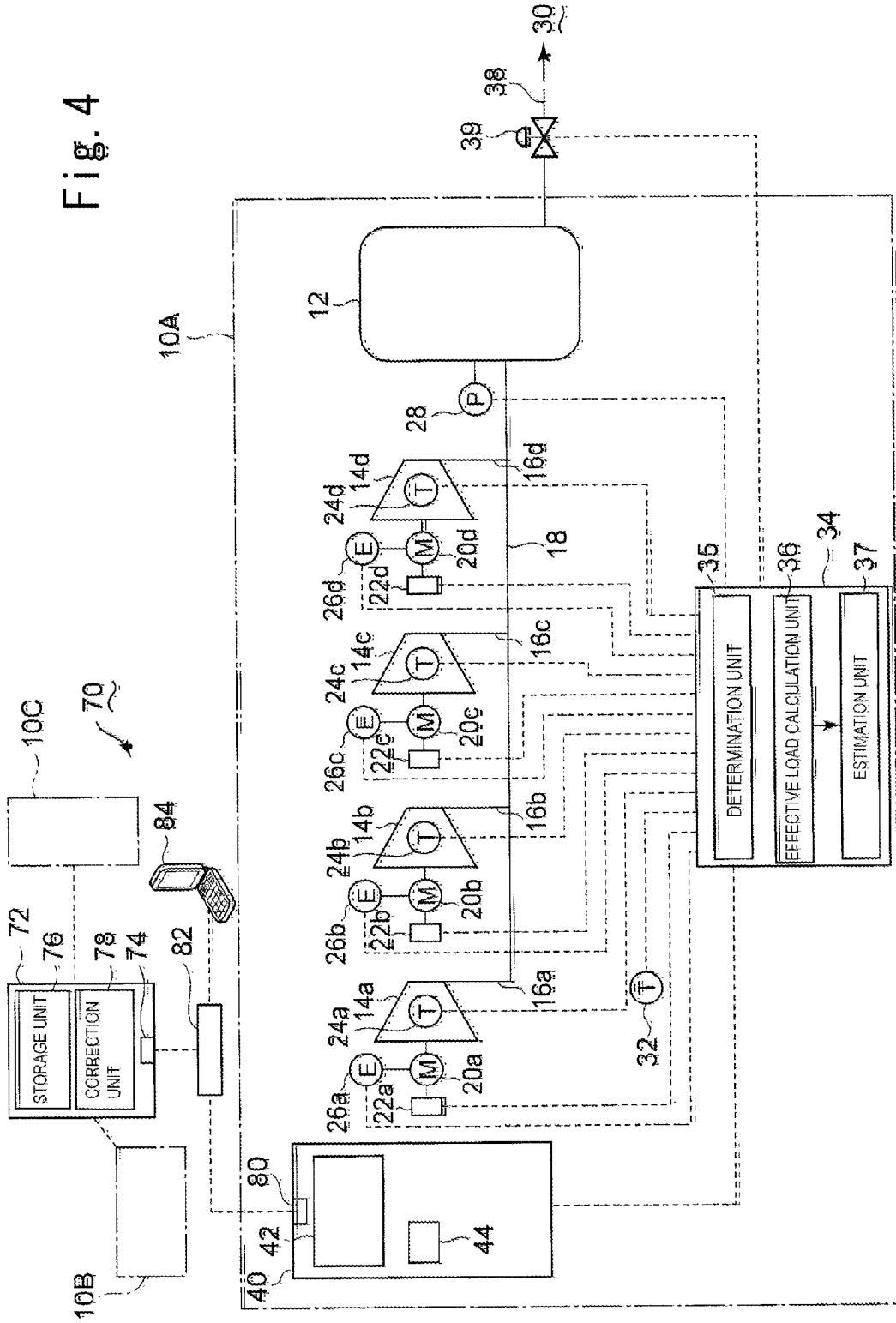
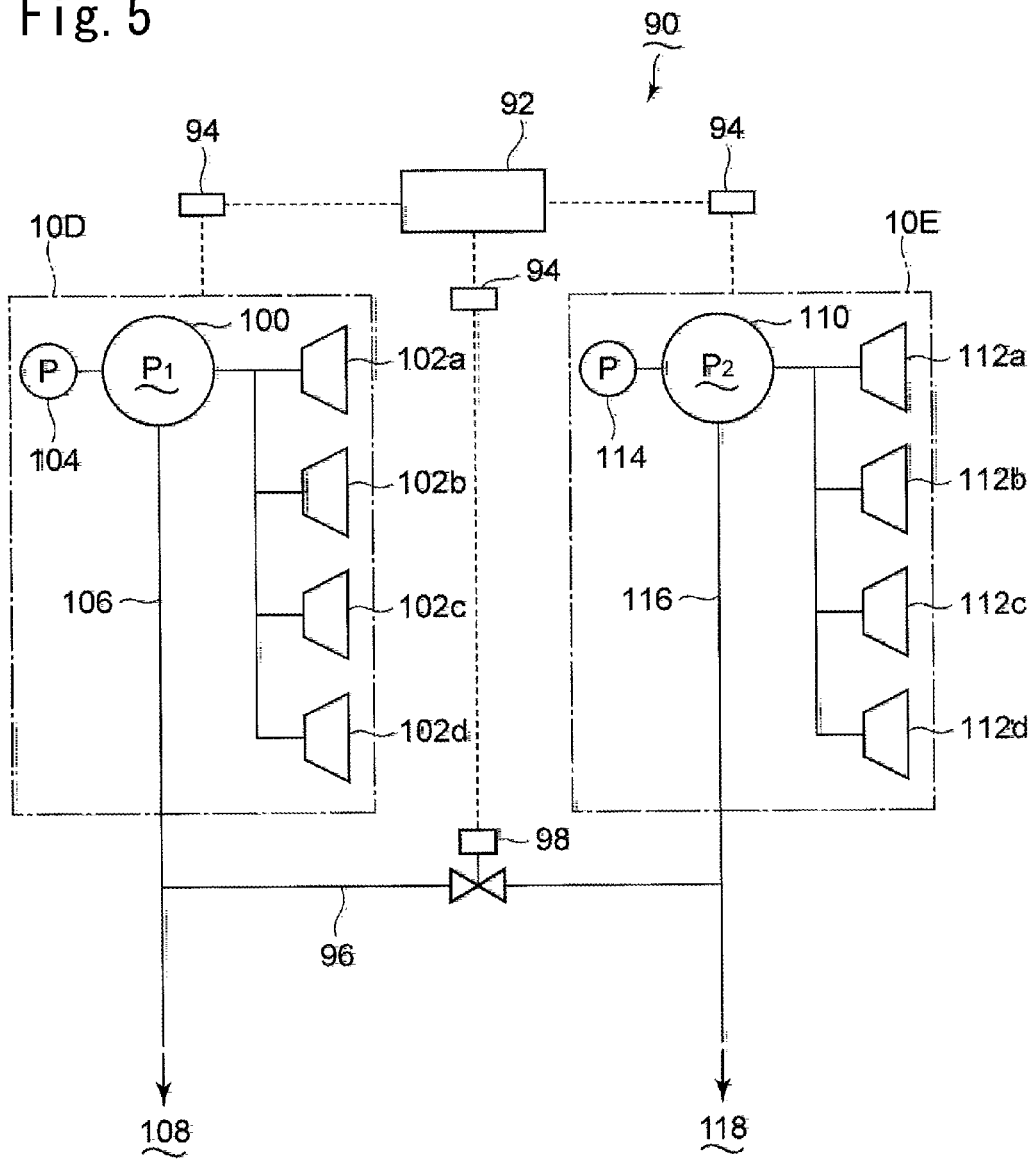

Fig. 5



**COMPRESSED GAS SUPPLY UNIT,  
COMPRESSED GAS SUPPLY APPARATUS  
AND CONTROL METHOD OF SAID UNIT  
AND SAID APPARATUS**

BACKGROUND OF THE INVENTION

**[0001]** 1. Field of the Invention

**[0002]** The present invention relates to a compressed gas supply unit which includes a plurality of compressors and allows the energy-saving operation of the compressors and saving of a maintenance cost, a compressed gas supply apparatus, and a control method of the unit and the apparatus.

**[0003]** 2. Description of the Related Art

**[0004]** There is known a compressed gas supply unit which includes a plurality of compressors and supplies compressed gas to a gas recipient while controlling the number of compressors under operating condition according to a demand. In such a compressed gas supply unit, energy saving is achieved by minimizing the number of compressors under operating condition. Japanese Patent Application Laid-open No. 2010-190197 discloses a compressed gas supply unit which includes a shared storage tank which stores gas discharged from a plurality of compressor and a pressure sensor which detects the internal pressure of the storage tank, grasps a change in the amount of consumed gas using the internal pressure of the storage tank, and controls the number of compressors under operating condition according to the detected value of the pressure sensor.

**[0005]** Japanese Patent Application Laid-open No. 2010-53733 discloses that, in a compressed gas supply unit having a plurality of air compressors, the surplus of the ability of each air compressor is calculated from a power consumption amount measured in each air compressor under operating condition in the control of the number of operated compressors. In addition, Japanese Patent Application Laid-open No. 2003-91313 discloses a remote monitoring system which remotely monitors the operation of a plurality of compressors disposed at remote sites. In the remote monitoring system, a server of a server-client system is provided in a remote monitoring center, and operation information on the compressors separately disposed in a plurality of client plants and the like is downloaded into the server via the Internet or a public network.

**[0006]** Japanese Patent Application Laid-open No. 2008-258935 discloses a remote monitoring system in which a plurality of compressors are connected to a personal computer with a LAN (wired) cable and the operating states of the plurality of compressors are monitored using the personal computer.

**[0007]** Although Japanese Patent Application Laid-open No. 2010-53733 discloses that the surplus of the ability of each compressor is calculated from the power consumption of each compressor, the pressure on the discharge side of the compressor also influences the power consumption of the compressor, and hence it is not possible to accurately calculate the surplus of the compressor only from the power consumption of the compressor. That is, with the recent prevalence of an inverter, the load fluctuation of the compressor is no longer raster. In addition, the power efficiency of the compressor changes depending on the way to operate the compressor. For example, the power efficiency of the compressor in an unloaded operation is lowered.

**[0008]** In the system in which the compressor provided in the client plant and the personal computer provided in the

monitoring center or the like are connected with the LAN cable as the remote monitoring system of a compressed gas supply apparatus, information on other clients may be leaked out of the LAN cable, and hence the system has a security problem. In addition, the system requires a construction cost for providing a network line to the compressor.

**[0009]** In the compressed gas supply unit, energy saving can be achieved by the combined use of an operation in which a plurality of compressors are operated with equal loads and control of the number of compressors under operating condition. In addition, with the equal load operation, it is possible to eliminate an irregularity in the maintenance timing of the compressor and reduce the maintenance frequency of the entire compressed gas supply unit to thereby save a maintenance cost and improve the utilization rate of the compressed gas supply unit.

SUMMARY OF THE INVENTION

**[0010]** In view of the problem of the conventional art described above, a first object of the present invention is to provide a compressed gas supply unit including a plurality of compressors which allows an equal load operation of the plurality of compressors while monitoring the operating state of each compressor and achieves energy saving and saving of a maintenance cost by using the equal load operation and control of the number of compressors under operating condition in combination. A second object of the present invention is to realize a low-cost remote control unit without any security problem in a case where a plurality of the compressed gas supply units disposed at positions apart from each other are remotely controlled.

**[0011]** A compressed gas supply unit of a first aspect of the present invention (hereinafter referred to as "an apparatus of a first aspect of the present invention") is a compressed gas supply unit including a plurality of compressors, a storage tank which stores discharged gas of the compressors, a compressed gas supply pipe which supplies compressed gas to a gas recipient from the storage tank, and a pressure sensor which detects a pressure of the storage tank, the compressed gas supply unit controlling an operation of each of the compressors based on a detected value of the pressure sensor, and including an operating state amount sensor which detects an operating state amount of the compressor, a power sensor which detects a power consumption of each compressor, and a controller which controls the operation of each compressor.

**[0012]** The controller includes a determination unit which determines that the compressor is abnormal when the detected value of the operation state amount sensor exceeds a threshold, an effective load calculation unit which calculates an effective load of each compressor from the detected values of the power sensor and the pressure sensor, and an estimation unit which estimates a maintenance timing of each compressor from an average value of the calculated effective load in an operation time. The operation time may be, e.g., the operation time of the compressed gas supply unit after the previous maintenance, but is not particularly limited thereto.

**[0013]** The determination unit determines the presence or absence of the abnormality of each compressor, and the operation of each compressor is controlled based on the effective load of each compressor calculated by the effective load calculation unit such that the loads of the compressors are equalized. In addition, the maintenance is executed based on the maintenance timing estimated by the estimation unit.

**[0014]** The effective load calculation unit detects the power consumption of each compressor and the internal pressure of the storage tank, and calculates the effective load of each compressor from the detected values. The effective load of the compressor is influenced not only by the power consumption of the compressor, but also by the internal pressure of the storage tank. Consequently, both of the power consumption of the compressor and the internal pressure of the storage tank are detected and the effective load of each compressor is calculated from the two detected values, and hence it is possible to accurately calculate the effective load. Next, the average value of the calculated effective load in the operation time is calculated and the maintenance timing is estimated from the foregoing average value, and hence it is possible to estimate the accurate maintenance timing.

**[0015]** Thus, since the equal load operation of the compressors is performed based on the calculated effective load, the energy saving of the compressed gas supply unit is made possible by the combined use of the equal load operation and control of the number of compressors under operating condition. In addition, with the equal load operation, it is possible to eliminate an irregularity in the maintenance timing of the compressor and reduce the maintenance frequency of the entire compressed gas supply unit. As a result, it is possible to save the maintenance cost and also improve the utilization rate of the compressed gas supply unit. Further, with the estimation unit, it is possible to accurately estimate the maintenance timing of the compressor.

**[0016]** The effective load calculation unit may be a unit which determines a correlation map of the power sensor, the pressure sensor, and the effective load from a pre-measured value and determines the effective load of the compressor from the correlation map. With this, even in a case where at least a part of the compressors is in an unloaded operation, which is inefficient in power, or an inverter is incorporated into the compressor, it is possible to accurately grasp the effective load of the compressor, whereby it becomes possible to perform control of the optimum and minimum number of compressors and achieve the energy saving.

**[0017]** The operation state amount sensor may include a first temperature sensor which detects an air temperature around the compressors, and a second temperature sensor which detects an operation temperature of each compressor, and the determination unit of the controller may be a unit which determines that the compressor is abnormal when a difference between the detected values of the first temperature sensor and the second temperature sensor exceeds a threshold. The operation temperature of the compressor is, e.g., the temperature of the discharged gas or a discharge path, or the temperature of a partition forming a compression chamber. With this, it is possible to eliminate the influence of the air temperature around the compressors exerted on the operation temperature of the compressor and accurately grasp the presence or absence of the abnormality of the compressor. In addition, since the temperature sensor is used, it is possible to make the apparatus configuration relatively simple and make its cost lower.

**[0018]** The operation state amount sensor may be a second pressure sensor which detects a pressure of the discharged gas of the compressor, and the determination unit of the controller may be a unit which determines that the compressor is abnormal when a difference between the detected values of the pressure sensor and the second pressure sensor exceeds a

threshold. With this, it becomes possible to perform the accurate determination without the influence of the internal pressure of the storage tank.

**[0019]** The apparatus of the first aspect of the present invention may include an inverter capable of controlling the RPM of the compressor, and the controller may control the operation of the compressor via the inverter. With this, it is possible to individually control the loads of the compressors, and hence the equal load operation is facilitated.

**[0020]** A compressed gas supply apparatus of a second aspect of the present invention (hereinafter referred to as “an apparatus of a second aspect of the present invention”) includes a plurality of the compressed gas supply units disposed at positions apart from each other and a central controller which can perform data communication by means of a wireless access system with the plurality of compressed gas supply units. The central controller includes a storage unit which stores detected value data received from the plurality of compressed gas supply units, and a correction unit which corrects the threshold from the detected value data accumulated in the storage unit and a result of an actual abnormality occurrence of the compressor, and controls each of the compressed gas supply units based on the corrected threshold.

**[0021]** The result of the actual abnormality occurrence of the compressor mentioned herein means, e.g., data obtained when an operator visually identifies the abnormality, and the operator inputs the data such as the threshold or the like at the time of the identification in the central controller. According to the apparatus of the second aspect of the present invention, by successively correcting the threshold in conjunction with watching the result of the actual abnormality occurrence of the compressor, it is possible to accurately determine the presence or absence of the abnormality of the compressor. In addition, the presence or absence of the abnormality of the compressor is determined based on a population of the high detected values collected from the plurality of compressed gas supply units, and hence it becomes possible to perform the accurate determination.

**[0022]** A compressed gas supply apparatus of the present invention (hereinafter referred to as “an apparatus of a third aspect of the present invention”) includes a plurality of the compressed gas-supply units disposed at positions apart from each other, a central controller which remotely controls the operation of the plurality of compressed gas supply units, a connection pipe which connects the compressed gas supply pipes of the plurality of compressed gas supply units, and an on-off valve provided in the connection pipe, and the central controller remotely controls the on-off valve based on a detected value of a pressure of a storage tank received from each of the plurality of compressed gas supply units.

**[0023]** According to the apparatus of the third aspect of the present invention, it is possible to supply the compressed gas to a plurality of gas recipients via the connection pipe from one compressed gas supply unit. In addition, it is possible to send the compressed gas to the plurality of gas recipients in conjunction with monitoring the storage state of the compressed gas in the storage tank of each compressed gas supply unit by means of the central controller, whereby it is possible to efficiently utilize the compressed gas produced by the plurality of compressed gas supply units.

**[0024]** A control method of a compressed gas supply unit of the present invention (hereinafter referred to as “a method of a first aspect of the present invention”) is for a compressed gas supply unit which temporarily stores discharged gas out of a

plurality of compressors in a storage tank, supplies compressed gas to a gas recipient from the storage tank, detects an internal pressure of the storage tank, and controls an operation of each of the compressors based on a detected value of the pressure.

**[0025]** A first step of the method of the first aspect of the present invention detects an operating state amount of each of the plurality of compressors and determines that the compressor is abnormal when the detected value exceeds a threshold. As the operation state amount, for example, the air temperature around the compressors and the operation temperature of each compressor are detected and it is determined that the compressor is abnormal when a difference between these detected temperature values exceeds a threshold. With this, it is possible to eliminate the influence of the air temperature around the compressors exerted on the compressor and accurately grasp the presence or absence of the abnormality of the compressor. In addition, since the temperature sensor is used, it is possible to make the apparatus configuration relatively simple and make its cost lower. As described above, the operation temperature of the compressor is, e.g., the temperature of the discharged gas or the discharge path, or the temperature of the partition forming the compression chamber.

**[0026]** As another step, the internal pressure of the storage tank and a pressure of the discharged gas of each compressor may be detected and it may be determined that the compressor is abnormal when a difference between these detected pressure values exceeds a threshold. With this, it becomes possible to perform the accurate determination without the influence of the internal pressure of the storage tank. In addition, since the internal pressure of the storage tank and the pressure of the discharge gas of each compressor are detected, it becomes possible to perform the accurate determination.

**[0027]** A second step detects a power consumption of each compressor and the internal pressure of the storage tank, and calculates an effective load of each compressor from these detected values. The effective load of the compressor is influenced not only by the power consumption of the compressor, but also by the internal pressure of the storage tank. Consequently, both of the power consumption of the compressor and the internal pressure of the storage tank are detected and the effective load of each compressor is calculated from the two detected values so that it is possible to accurately calculate the effective load. Next, an average value of the calculated effective load in an operation time is calculated and maintenance timing is estimated from the average value. With this, it becomes possible to estimate the accurate maintenance timing. The operation time may be, e.g., the operation time of the compressed gas supply unit after the previous maintenance, but is not particularly limited thereto.

**[0028]** A third step controls the operation of each compressor based on the effective load of each compressor calculated in the second step such that the loads of the compressors are equalized. The energy saving of the compressed gas supply unit is made possible by the combined use of the equal load operation and the control of the number of compressors under operating condition. In addition, with the equal load operation, it is possible to eliminate the irregularity in the maintenance timing of the compressor and reduce the maintenance frequency of the entire compressed gas supply unit, whereby it is possible to save the maintenance cost and improve the utilization rate of the compressed gas supply unit.

**[0029]** Note that, when the compressor is constituted of a multi-stage compressor, the first step may detect the opera-

tion temperature or the pressure of the discharged gas of the compressors other than the final high-pressure stage compressor. When an abrasion is caused in the discharge path of a low-pressure side compressor by the operation of the multi-stage compressor, high-temperature and high-pressure gas of a high-pressure side compressor flows backward to the low-pressure side compressor and the temperature of the discharge path and the pressure of the discharge gas of the low-pressure side compressor are increased. Consequently, by detecting the temperature of the discharge path or the pressure of the discharge gas of the low-pressure side compressor, it is possible to detect the presence or absence of the backward flow of the high-temperature and high-pressure gas. With this, it is possible to accurately grasp the progress of fatigue of the compressor, and hence it is possible to properly estimate the maintenance timing.

**[0030]** A control method of a compressed gas supply apparatus of the present invention (hereinafter referred to as "a method of a second aspect of the present invention") is for a compressed gas supply apparatus which includes a plurality of the compressed gas supply units disposed at positions apart from each other and a central controller which can perform data communication by means of a wireless access system with the compressed gas supply units.

**[0031]** First to third steps of the method of the second aspect of the present invention are the same as the first to third steps of the method of the first aspect of the present invention. Fourth to sixth steps of the method of the second aspect of the present invention include the fourth step of transmitting detected value data to the central controller from the compressed gas supply units, the fifth step of causing a storage unit of the central controller to store the detected value data of the compressed gas supply units, and the sixth step of correcting the threshold from the detected value data accumulated in the storage unit and a result of an actual abnormality occurrence of the compressor and controlling each compressed gas supply unit based on the corrected threshold.

**[0032]** The result of the actual abnormality occurrence of the compressor mentioned herein means, e.g., data obtained when the operator visually identifies the abnormality, and the operator inputs the data such as the threshold or the like at the time of the identification in the central controller. By successively correcting the threshold from the result of the actual abnormality occurrence of the compressor, it is possible to determine the presence or absence of the abnormality of the compressor further accurately. In addition, the presence or absence of the abnormality of the compressor is determined based on the population of the high detected values collected from the plurality of compressed gas supply units, and hence it becomes possible to perform the accurate determination.

**[0033]** According to the apparatus of the first aspect of the present invention and the method of the first aspect of the present invention, since it is possible to accurately grasp the abnormality of the compressor during the operation and perform the operation in which the loads of the compressors are equalized, the combined use of the equal load operation and the control of the number of operated compressors allows energy saving, and can reduce the maintenance frequency and save the maintenance cost. In addition, according to the apparatus of the second aspect of the present invention and the method of the second aspect of the present invention, in addition to the operation and effect described above, by successively correcting the threshold related to the difference between the air temperature around the compressors and the



operation temperature of the compressor, it is possible to determine the presence or absence of the abnormality of the compressor further accurately. Additionally, according to the apparatus of the third aspect of the present invention, it is possible to efficiently supply the compressed gas produced by the plurality of compressed gas supply units to a plurality of gas recipients on the demands thereof.

#### BRIEF DESCRIPTION OF THE DRAWINGS

[0034] FIG. 1 is a system diagram of a compressed gas supply unit according to a first embodiment of each of an apparatus of a first aspect of the present invention and a method of a first aspect of the present invention;

[0035] FIG. 2 is a correlation map for determining the effective load of a compressor in the first embodiment;

[0036] FIG. 3 is a partial system diagram of a compressed gas supply unit according to a second embodiment of each of the apparatus of the first aspect of the present invention and the method of the first aspect of the present invention;

[0037] FIG. 4 is a system diagram of a compressed gas supply apparatus according to an embodiment of each of an apparatus of a second aspect of the present invention and a method of a second aspect of the present invention; and

[0038] FIG. 5 is a system diagram of a compressed gas supply apparatus according to an embodiment of an apparatus of a third aspect of the present invention.

#### DESCRIPTION OF THE PREFERRED EMBODIMENTS

[0039] Hereinbelow, the present invention will be described in detail by using embodiments shown in the drawings. Note that the scope of the present invention is not limited to dimensions, materials, shapes, and relative arrangements of constituent parts described in the embodiments unless specifically described.

##### First Embodiment

[0040] A first embodiment of each of an apparatus of a first aspect of the present invention and a method of a first aspect of the present invention will be described with reference to FIGS. 1 and 2. A compressed gas supply unit 10A of the present embodiment includes one storage tank 12 and four compressors 14a to 14d. Discharge paths 16a to 16d of the individual compressors are connected to a main supply pipe 18, and the main supply pipe 18 is connected to the storage tank 12. Gas discharged from each compressor flows through the main supply pipe 18 and is stored in the storage tank 12.

[0041] The individual compressors are provided with drive motors 20a to 20d and inverters 22a to 22d which can control the RPMs of the drive motors steplessly. With this, the RPMs of the individual motors can be individually controlled. Temperature sensors 24a to 24d which detect the temperatures of compressed gas are provided on the partitions of compression chambers of the individual compressors. The compressors are provided with power sensors 26a to 26d which detect power consumptions of the drive motors 20a to 20d.

[0042] The storage tank 12 is provided with a pressure sensor 28 which detects an internal pressure in the storage tank 12. A temperature sensor 32 which detects an air temperature around the compressors is provided in the vicinity of the compressors 14a to 14d. Detection signals of the temperature sensors 24a to 24d, the power sensors 26a to 26d, the

pressure sensor 28, and the temperature sensor 32 are sent to a controller 34 provided in a monitoring room or the like.

[0043] The controller 34 opens or closes an on-off valve 39 provided in a compressed gas supply pipe 38 to supply compressed gas to a gas recipient 30 in conjunction with monitoring the detected value of the pressure sensor 28. The controller 34 has a determination unit 35, an effective load calculation unit 36, and an estimation unit 37. The determination unit 35 determines the presence or absence of the abnormality of each of the compressors 14a to 14d from a difference  $\Delta T$  between the detected value of the temperature sensor 32 and the detected value of each of the temperature sensors 24a to 24d. That is, when the difference  $\Delta T$  exceeds a threshold  $\Delta T_s$ , the determination unit 35 determines that the state of the compressor is abnormal.

[0044] The effective load calculation unit 36 calculates the effective load of each of the compressors 14a to 14d from the detected values of the pressure sensor 28 and the power sensors 26a to 26d. FIG. 2 is a map showing the correlation of the power consumption of each of the compressors 14a to 14d, the internal pressure of the storage tank 12, and the effective load of each of the compressors 14a to 14d which are determined from pre-measured test data by using the compressor having the same type and capacity as those of each of the compressors 14a to 14d. The effective load of each of the compressors 14a to 14d is calculated from the detected values of the pressure sensor 28 and the power sensors 26a to 26d by using the map.

[0045] The estimation unit 37 estimates the maintenance timing of each compressor from the average value of the effective load calculated in the effective load calculation unit 36 in an operation time. In the present embodiment, the operation time is assumed to be the operation time of the compressed gas supply unit 10A from the time point of start of the operation after the previous maintenance to the time point of the calculation. However, in the present invention, the operation time is not limited thereto and other times may be set as the operation time. The average value is calculated with the stop time of each compressor included, and the average value is calculated for each compressor. Alternatively, the average value of the four compressors may also be calculated instead of calculating the average value for each compressor.

[0046] A monitoring device 40 is provided in the monitoring room or the like. To the monitoring device 40, the detection signal of each sensor is sent from the controller 34, and the determination result of the determination unit 35, the effective load of each compressor calculated in the effective load calculation unit 36, and the signal indicative of the next maintenance timing estimated in the estimation unit 37 are also sent. The monitoring device 40 includes a display unit 42 and an alarm device 44. The display unit 42 displays the detected value of each sensor, the determination result of the determination unit 35, the effective load calculated in the effective load calculation unit 36, and the next maintenance timing estimated in the estimation unit 37.

[0047] The controller 34 performs an operation in which control of the number of compressors which minimizes the number of compressors under operating condition with respect to the load of the compressed gas supply unit 10A and an equal load operation which controls the inverters 22a to 22d of the individual compressors 14a to 14d based on the effective loads of the individual compressors calculated in the effective load calculation unit 36 such that the loads of the compressors 14a to 14d are equalized, are used in combina-

tion. In addition, when the determination result of the determination unit 35 indicates the presence of the abnormality, the alarm device 44 issues an alarm. Further, an operator performs the maintenance based on the next maintenance timing displayed in the display unit 42.

[0048] According to the present embodiment, since the determination unit 35 of the controller 34 determines the presence or absence of the abnormality of each compressor based on the difference  $\Delta T$  between the temperature around the compressors 14a to 14d and the compressed gas temperature of the compression chamber of each of the compressors 14a to 14d, it becomes possible to perform accurate abnormality determination without the influence of the air temperature. In addition, since the temperature sensor is used, it is possible to make the apparatus configuration relatively simple and make its cost lower.

[0049] In addition, since the effective load of each of the compressors 14a to 14d is calculated from the correlation map shown in FIG. 2 in the effective load calculation unit 36 of the controller 34, it is possible to calculate the accurate effective load. Further, since the controller 34 performs the operation in which the control of the number of compressors and the equal load operation are used in combination, energy saving is made possible. Furthermore, with the equal load operation, it is possible to eliminate an irregularity in the maintenance timing of the compressor and reduce the maintenance frequency of the entire compressed gas supply unit, whereby it is possible to save the maintenance cost and improve the utilization rate of the compressed gas supply unit.

[0050] In addition, since there are provided the inverters 22a to 22d which can control the RPMs of the compressors 14a to 14d individually, the load control of each compressor is facilitated. In the present embodiment, although the controller 34 and the monitoring device 40 are separately provided, an integrated monitoring controller having these functions may also be used instead.

[0051] Although the effective loads of the compressors 14a to 14d are calculated from the detected values of the pressure sensor 28 and the power sensors 26a to 26d in the present embodiment, the pressure of the discharged gas of each of the compressors 14a to 14d may be detected instead, and when the difference between the detected value of the pressure sensor 28 and the detected value of the pressure of the discharged gas of the compressor exceeds a threshold, it may be determined that the corresponding compressor is abnormal. With this, it becomes possible to perform accurate determination without the influence of the internal pressure of the storage tank 12.

#### Second Embodiment

[0052] Next, a second embodiment of each of the apparatus of the first aspect of the present invention and the method of the first aspect of the present invention will be described with reference to FIG. 3. A two-stage compressor 50 constituting a compressed gas supply unit 10B of the present embodiment includes a low-pressure side compressor 52 and a high-pressure side compressor 54. That is, the low-pressure side compressor 52 and the high-pressure side compressor 54 are driven by a shared rotating shaft 58, and the rotating shaft 58 is driven by a drive motor 56. Gas discharged from the low-pressure side compressor 52 is supplied to the high-pressure side compressor 54 via an intermediate discharge path 60, further compressed in the high-pressure side compressor 54,

and sent to the storage tank (not shown). The RPM of the drive motor 56 can be steplessly adjusted by an inverter 62.

[0053] The intermediate discharge path 60 is provided with a temperature sensor 64 which detects the temperature of the intermediate discharge path 60, and the drive motor 56 is provided with a power sensor 66 which detects the power consumption of the drive motor 56. The detection signals of these sensors are sent to the monitoring device 40, and the inverter 62 is controlled by the controller 34. The configuration of the compressed gas supply unit 10B is otherwise the same as that of the first embodiment.

[0054] In the two-stage compressor 50, when an abrasion or the like progresses in a portion constituting the compression chamber, high-pressure air of the high-pressure side compressor 54 may flow backward to the low-pressure side compressor 52 through the intermediate discharge path 60. According to the present embodiment, the temperature of the intermediate discharge path 60 is detected as the operation temperature of the two-stage compressor 50, and hence it is possible to detect the presence or absence of the backward flow of the high-pressure air. With this, it is possible to accurately grasp the progress of fatigue of the two-stage compressor 50, and hence it is possible to accurately grasp the maintenance timing of the two-stage compressor 50.

[0055] Note that, in the present embodiment as well, instead of the temperature of the intermediate discharge path 60, the pressure of the discharge air of the intermediate discharge path 60 may be detected, and when the difference between the pressure of the discharge air and the internal pressure of the storage tank 12 exceeds a threshold, it may be determined that the compressor is abnormal. With this, it becomes possible to perform the accurate determination without the influence of the internal pressure of the storage tank 12.

#### Third Embodiment

[0056] Next, an embodiment of each of an apparatus of a second aspect of the present invention and a method of a second aspect of the present invention will be described with reference to FIG. 4. A compressed gas supply apparatus 70 of the present embodiment includes a plurality of compressed gas supply units 10A, 10B, and 10C provided at positions apart from each other and a central control unit 72 which can remotely control the compressed gas supply units. Each of the compressed gas supply units 10A and 10C has the same configuration as that of the compressed gas supply unit 10A of the first embodiment, and the compressed gas supply unit 10B has the same configuration as that of the compressed gas supply unit 10B of the second embodiment.

[0057] The compressed gas supply unit 10A and the central control unit 72 are provided with transmitter-receivers 74 and 80 respectively. The compressed gas supply unit 10A and the central control unit 72 can perform data communication therebetween by means of a data communication network 82 of a wireless access system provided by a cellular phone carrier. The central control unit 72 and the compressed gas supply unit 10B or 10C can also perform the data communication therebetween by means of the same wireless access system. Data such as detected values and the like held by the monitoring device 40 of each compressed gas supply unit is sent to the central control unit 72 through the data communication network 82.

[0058] The central control unit 72 has a storage unit 76 and a correction unit 78. The detected values of the temperature

sensors **24a** to **24d** and **32** received from the compressed gas supply units **10A**, **10B**, and **10C** are stored in the storage unit **76**. In the correction unit **78**, the threshold  $\Delta T$ s related to the difference  $\Delta T$  between the detected value of the temperature sensor **32** and the detected value of each of the temperature sensors **24a** to **24d** is corrected based on the detected values stored in the storage unit **76** and the result of the actual abnormality occurrence of the compressor. The result of the actual abnormality occurrence of the compressor mentioned herein means data obtained when the operator visually identifies the abnormality, and the operator inputs the threshold  $\Delta T$ s at the time of the identification in the central control unit **72**.

**[0059]** The central control unit **72** controls the operation of each compressed gas supply unit based on the successively corrected threshold  $\Delta T$ s during the operation of the compressed gas supply apparatus **70**. Note that the monitoring device **40** of each compressed gas supply unit and the central control unit **72** may be accessed from a cellular phone **84** held by the operator via the data communication network **82**. That is, the operation state of each compressed gas supply unit may be monitored by receiving data from the central control unit **72** and the monitoring device **40** of each compressed gas supply unit by means of the cellular phone **84**.

**[0060]** According to the present embodiment, in addition to the operation and effect obtained in the first embodiment of each of the method of the first aspect of the present invention and the apparatus of the first aspect of the present invention, by successively correcting the threshold  $\Delta T$ s of each compressed gas supply unit in conjunction with watching the result of the actual abnormality occurrence of the compressor, it is possible to accurately determine the presence or absence of the abnormality of the compressor. In addition, the presence or absence of the abnormality of the compressor is determined based on a population of the high detected values collected from the plurality of compressed gas supply units, and hence it becomes possible to perform the accurate determination.

#### Fourth Embodiment

**[0061]** Next, an embodiment of an apparatus of a third aspect of the present invention will be described with reference to FIG. 5. A compressed gas supply apparatus **90** of the present embodiment includes two compressed gas supply units **10D** and **10E** and a central control unit **92** which controls the operation of the compressed gas supply units **10D** and **10E**. The compressed gas supply unit **10D** includes a storage tank **100**, four compressors **102a** to **102d**, a pressure sensor **104** which detects the internal pressure of the storage tank **100**, and a compressed gas supply pipe **106** which supplies compressed gas in the storage tank **100** to a gas recipient **108**.

**[0062]** The compressed gas supply unit **10E** includes a storage tank **110**, four compressors **112a** to **112d**, a pressure sensor **114** which detects the internal pressure of the storage tank **110**, and a compressed gas supply pipe **116** which supplies the compressed gas in the storage tank **110** to a gas recipient **118**. Each of the compressed gas supply units **10D** and **10E** has the same configuration as that of the compressed gas supply unit **10A** of FIG. 1. The compressed gas supply pipe **106** and the compressed gas supply pipe **116** are connected to each other by a connection pipe **96**. The connection pipe **96** is provided with an on-off valve **98**.

**[0063]** As in the above embodiment, the data communication can be performed between the central control unit **92** and the compressed gas supply unit **10D** or **10E** or the on-off valve **98** by means of data communication networks **94** of the wireless access system.

**[0064]** In the present embodiment, the opening/closing operation of the on-off valve **98** is controlled by the central control unit **92**. For example, in a case where the compressed gas is supplied to the gas recipient **108** and the internal pressure  $P_1$  of the storage tank **100**>the internal pressure  $P_2$  of the storage tank **110** is satisfied, it is possible to supply the compressed gas in the storage tank **100** to the gas recipient **118** by opening the on-off valve **98**. In this manner, it is possible to monitor the internal pressure  $P_1$  of the storage tank **100** and the internal pressure  $P_2$  of the storage tank **110** by using the central control unit **92** to send the compressed gas of the compressed gas-supply unit **10D** or **10E** to the gas recipient of the other compressed gas supply apparatus, whereby it is possible to efficiently supply the compressed gas to the plurality of gas recipients **108** and **118**.

**[0065]** The present invention allows the energy-saving operation and the maintenance cost reduction of a compressed gas supply unit including a plurality of compressors, and solves a security problem and allows low-cost remote control in a compressed gas supply apparatus including a plurality of the compressed gas supply units.

What is claimed is:

1. A compressed gas supply unit comprising a plurality of compressors, a storage tank which stores discharge gas of the compressors, a compressed gas supply pipe which supplies compressed gas to a gas recipient from the storage tank, and a pressure sensor which detects a pressure of the storage tank, the compressed gas supply unit controlling an operation of each of the compressors based on a detected value of the pressure sensor, and comprising:

- an operating state amount sensor which detects an operating state amount of the compressor;
- a power sensor which detects a power consumption of each compressor; and
- a controller which controls the operation of each compressor, wherein

the controller comprises a determination unit which determines that the compressor is abnormal when the detected value of the operating state amount sensor exceeds a threshold, an effective load calculation unit which calculates an effective load of each compressor from the detected values of the power sensor and the pressure sensor, and an estimation unit which estimates a maintenance timing of each compressor from an average value of the calculated effective load in an operation time, and the controller controls the operation of each compressor based on the calculated effective load of each compressor such that loads of the compressors are equalized.

2. The compressed gas supply unit according to claim 1, wherein the effective load calculation unit for the compressors is a unit which determines a correlation map of the power sensor, the pressure sensor, and the effective load from a pre-measured value and determines the effective load of the compressor from the correlation map.

3. The compressed gas supply unit according to claim 1, wherein the operating state amount sensor comprises a first temperature sensor which detects an air temperature around the compressors, and a second temperature sensor which

detects an operation temperature of each compressor, and the determination unit of the controller is a unit which determines that the compressor is abnormal when a difference between the detected values of the first temperature sensor and the second temperature sensor exceeds a threshold.

4. The compressed gas supply unit according to claim 1, wherein the operation state amount sensor is a second pressure sensor which detects a pressure of the discharge gas of the compressor, and the determination unit of the controller is a unit which determines that the compressor is abnormal when a difference between the detected values of the pressure sensor and the second pressure sensor exceeds a threshold.

5. The compressed gas supply unit according to claim 1, wherein each compressor comprises an inverter capable of controlling an RPM, and the controller controls the inverter such that loads of the compressors are equalized.

6. A compressed gas supply apparatus comprising:  
a plurality of the compressed gas supply units according to claim 1 disposed at positions apart from each other; and  
a central controller which can perform data communication by means of a wireless access system with the plurality of compressed gas supply units, wherein the central controller comprises a storage unit which stores detected value data received from the plurality of compressed gas supply units, and a correction unit which corrects the threshold from the detected value data accumulated in the storage unit and a result of an actual abnormality occurrence of the compressor, and controls each of the compressed gas supply units based on the corrected threshold.

7. A compressed gas supply apparatus comprising:  
a plurality of the compressed gas supply units according to claim 1 disposed at positions apart from each other;  
a central controller which can perform data communication by means of a wireless access system with the plurality of compressed gas supply units;  
a connection pipe which connects the compressed gas supply pipes of the plurality of compressed gas supply units; and

an on-off valve provided in the connection pipe, wherein the central controller remotely controls the on-off valve based on a detected value of a pressure of a storage tank received from each of the plurality of compressed gas supply units.

8. A control method of a compressed gas supply unit which temporarily stores discharged gas of a plurality of compressors in a storage tank, supplies compressed gas to a gas recipient from the storage tank, detects a pressure of the storage tank, and controls an operation of each of the compressors based on a detected value of the pressure, the control method comprising:

a first step of detecting an operating state amount of each compressor and determining that the compressor is abnormal when the detected value exceeds a threshold;  
a second step of detecting a power consumption of each compressor and an internal pressure of the storage tank, calculating an effective load of each compressor from the detected values, and estimating a maintenance timing of each compressor from an average value of the calculated effective load in an operation time; and

a third step of controlling the operation of each compressor based on the effective load of each compressor calculated in the second step such that the effective loads of the compressors are equalized.

9. The control method of a compressed gas supply unit according to claim 8, wherein the first step is a step of detecting an air temperature around the compressors and an operation temperature of each compressor and determining that the compressor is abnormal when a difference between these detected temperature values exceeds a threshold.

10. The control method of a compressed gas supply unit according to claim 8, wherein the first step is a step of detecting the internal pressure of the storage tank and a pressure of the discharge gas of each compressor and determining that the compressor is abnormal when a difference between these detected pressure values exceeds a threshold.

11. The control method of a compressed gas supply unit according to claim 9, wherein each compressor is constituted of a multi-stage compressor, and the operation temperature or the pressure of the discharge gas of the compressor is the operation temperature or the pressure of the discharge gas of the compressor other than a final high-pressure stage compressor.

12. A control method of a compressed gas supply apparatus comprising: a plurality of compressed gas supply units which are disposed at positions apart from each other, temporarily store discharge gas of a plurality of compressors in a storage tank, supply compressed gas to a gas recipient from the storage tank, detect a pressure of the storage tank, and control an operation of each of the compressors based on a detected value of the pressure; and a central controller which can perform data communication by means of a wireless access system with the compressed gas supply units, the control method comprising:

a first step of detecting an operating state amount of each compressor and determining that the compressor is abnormal when the detected value thereof exceeds a threshold;

a second step of detecting a power consumption of each compressor and an internal pressure of the storage tank, calculating an effective load of each compressor from the detected values, and estimating a maintenance timing of each compressor from an average value of the calculated effective load in an operation time;

a third step of controlling the operation of each compressor based on the effective load of each compressor calculated in the second step such that the effective loads of the compressors are equalized;

a fourth step of transmitting detected value data to the central controller from the compressed gas supply units;

a fifth step of causing a storage unit of the central controller to store the detected value data of the compressed gas supply units; and

a sixth step of correcting the threshold from the detected value data accumulated in the storage unit and a result of an actual abnormality occurrence of the compressor and controlling each compressed gas supply unit based on the corrected threshold.