



(19) **United States**

(12) **Patent Application Publication**  
**Leppla et al.**

(10) **Pub. No.: US 2014/0059752 A1**

(43) **Pub. Date: Mar. 6, 2014**

(54) **DISSOLVABLE UNIT DOSE APPLICATOR FOR CLEANING SUBSTANCES**

(76) Inventors: **Phoebe Leppla**, Pleasanton, CA (US);  
**Rachel Robinette**, Pleasanton, CA (US)

(21) Appl. No.: **13/605,792**

(22) Filed: **Sep. 6, 2012**

**Publication Classification**

(51) **Int. Cl.**  
**E03D 9/02** (2006.01)

(52) **U.S. Cl.**  
USPC ..... **4/231**

(57) **ABSTRACT**

An apparatus for applying a cleaning substance to a bathroom surface to be cleaned includes a body that is dissolvable in water, the body having an elongate, distally-facing wall defining a cavity for releasably retaining the cleaning substance until the body is dislodged by flowing water. For toilet surface applications, the apparatus includes a cleaning substance and a body that is dissolvable in water. The body has a distally-facing cavity for releasably retaining the cleaning substance and a proximally-extending gripping mechanism to permit the user to grip the body and then press the cleaning substance against the toilet surface. The body is configured to release the cleaning substance to permit the body to be dislodged. A method for applying a cleaning substance includes the following steps: employing the water dissolvable body to apply the cleaning substance to the toilet bowl; and removing the body thereby leaving the cleaning substance.

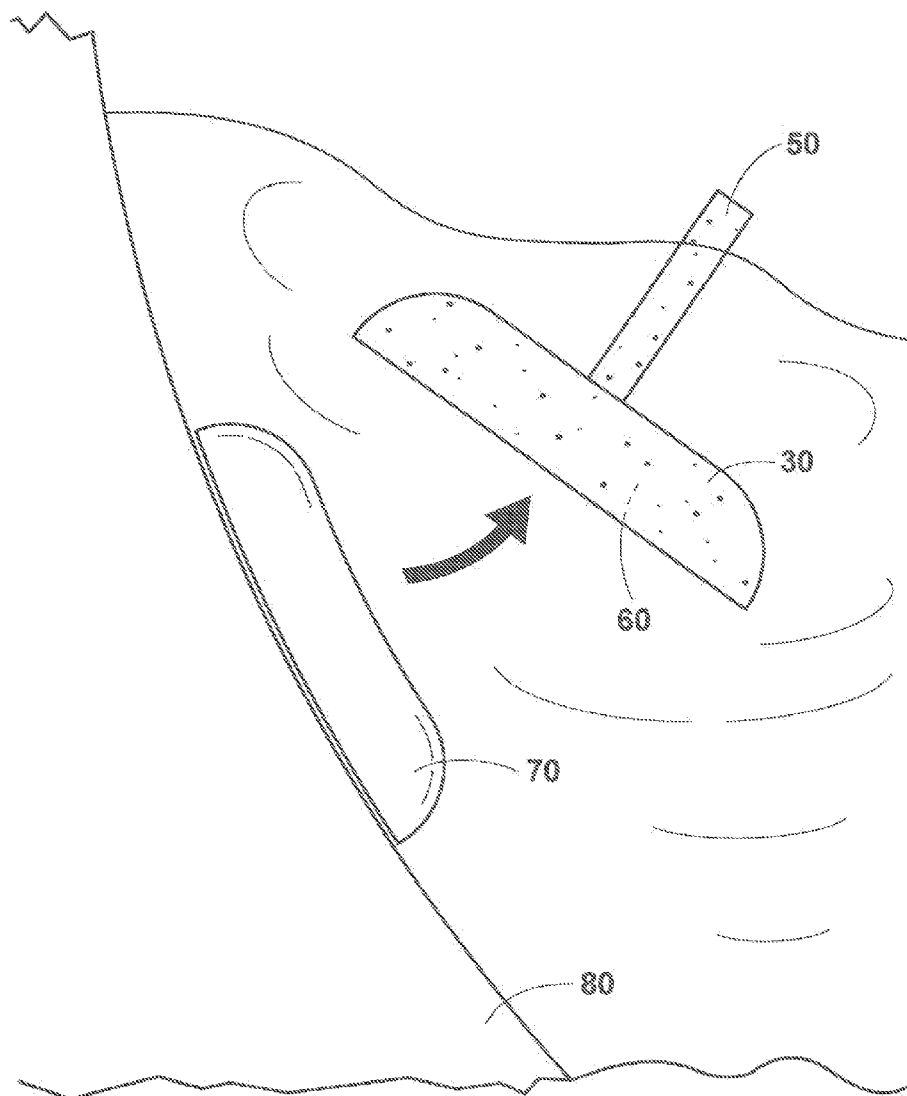

FIG. 1

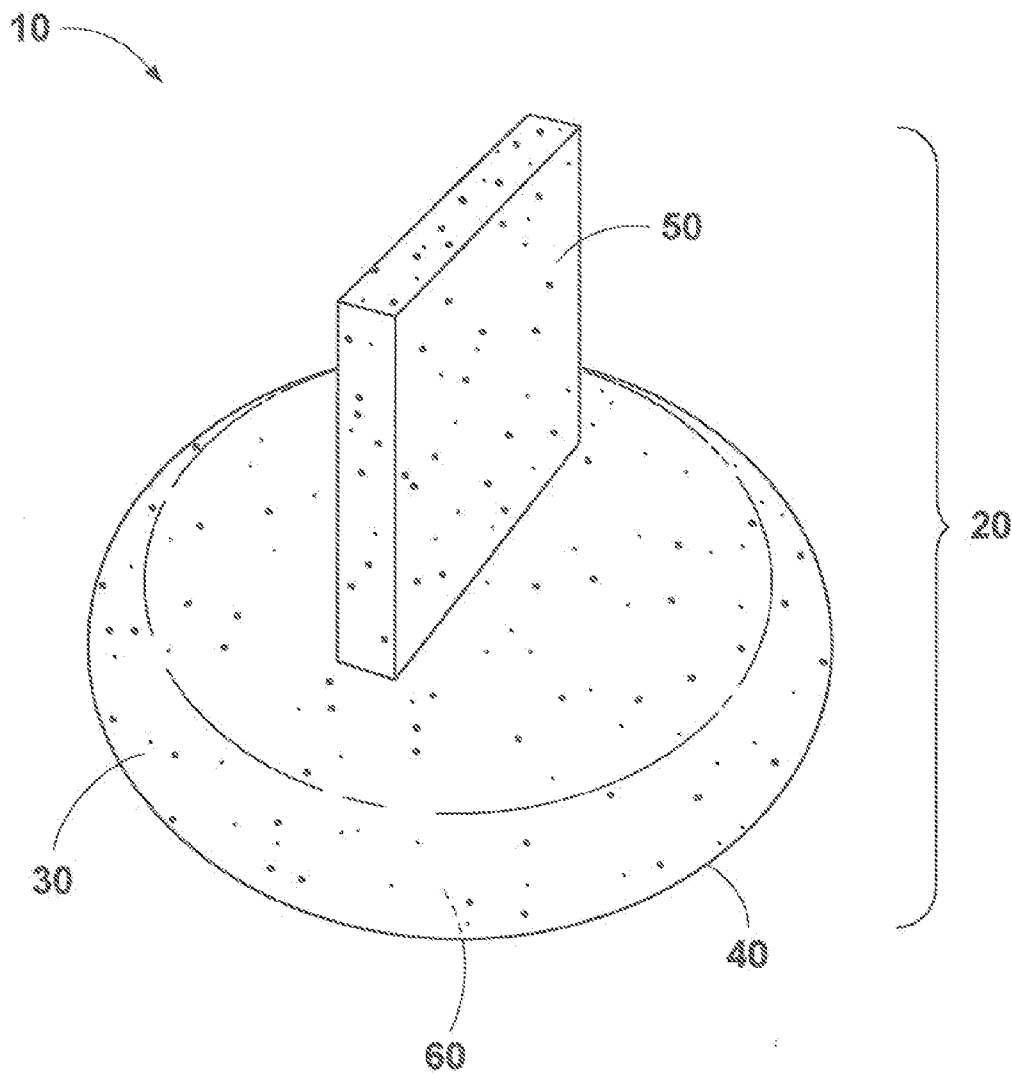

FIG. 2

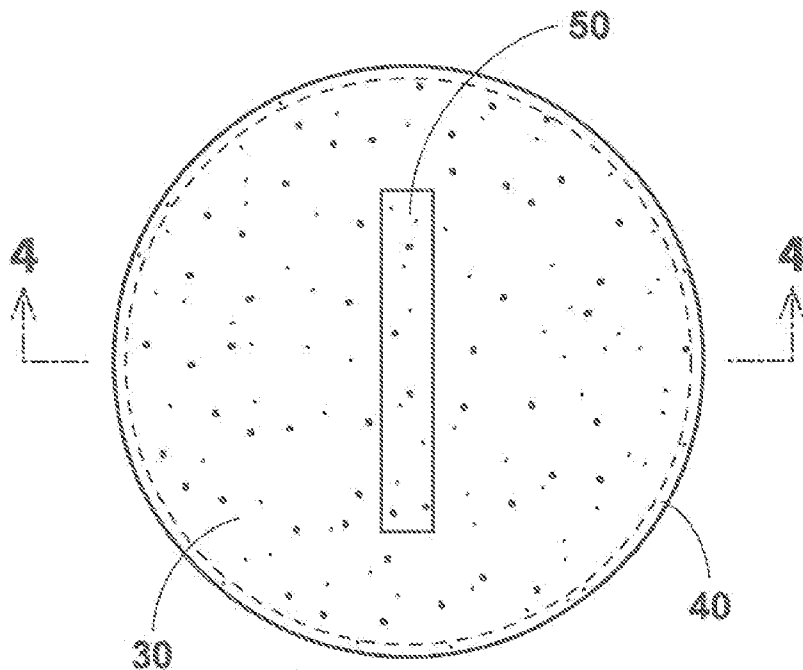

FIG. 3

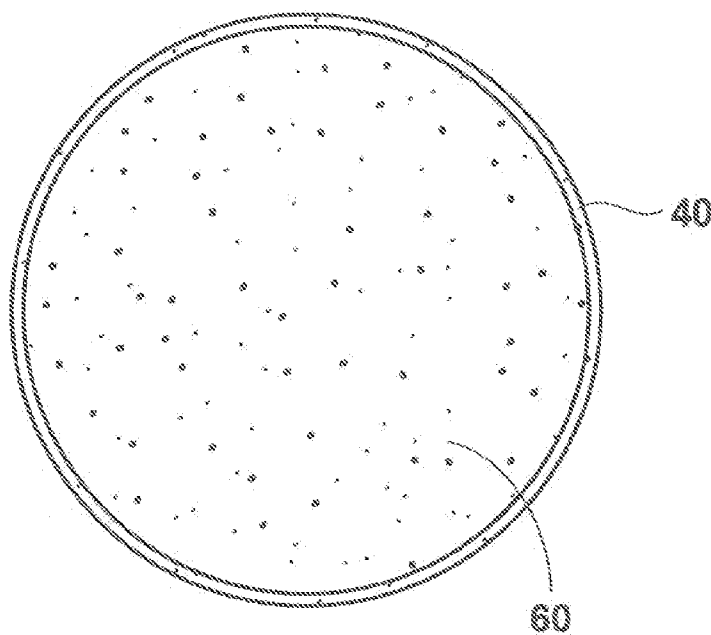

FIG. 4

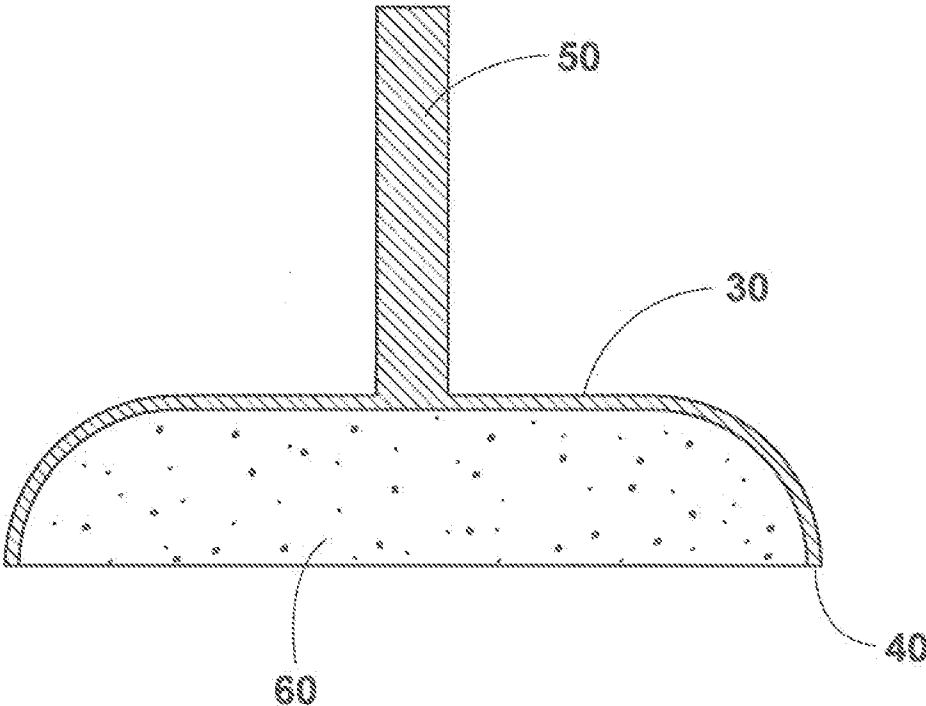
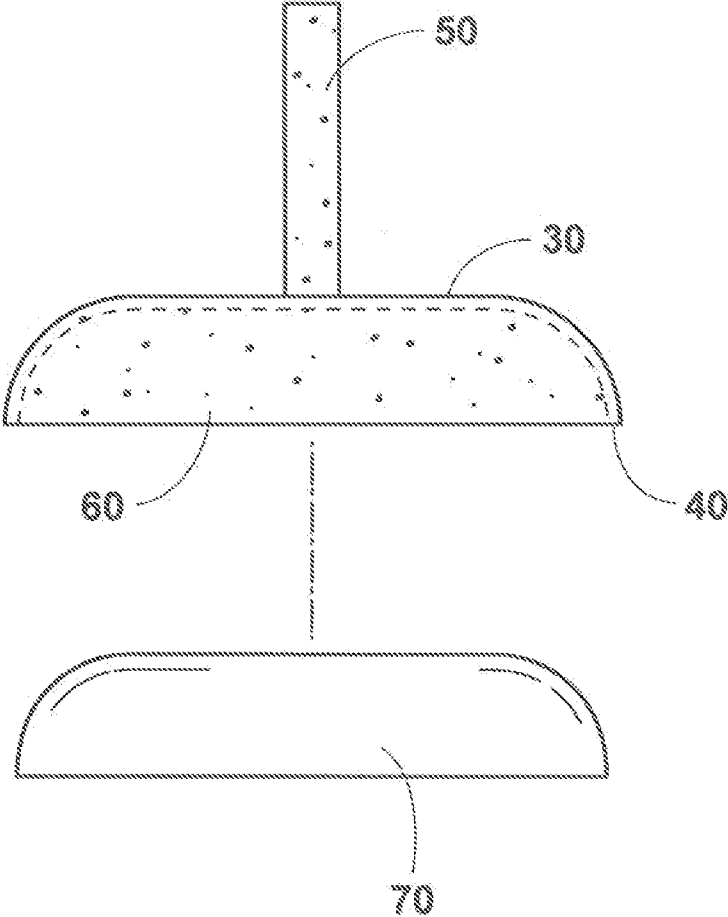

FIG. 5



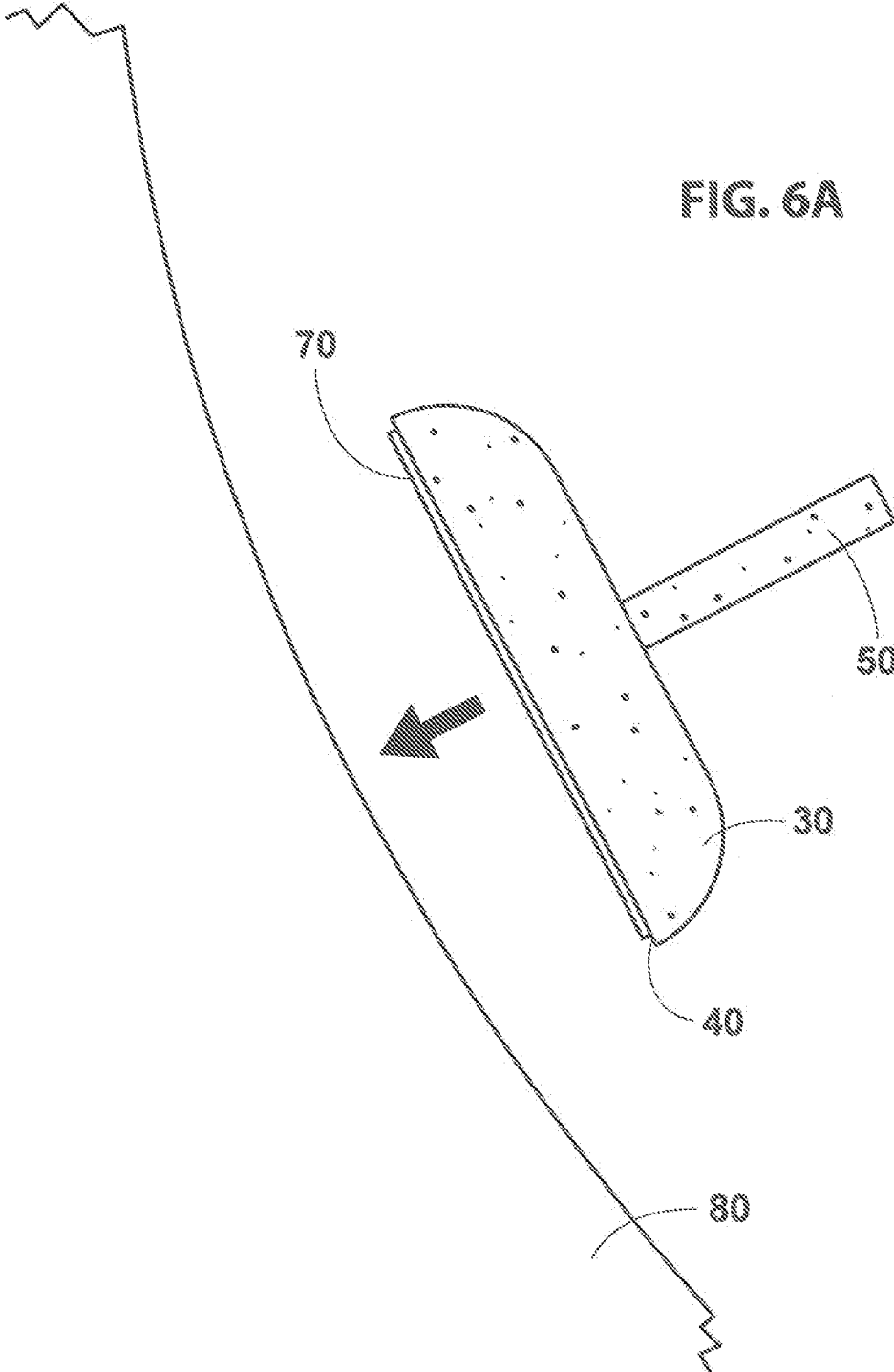

FIG. 6A

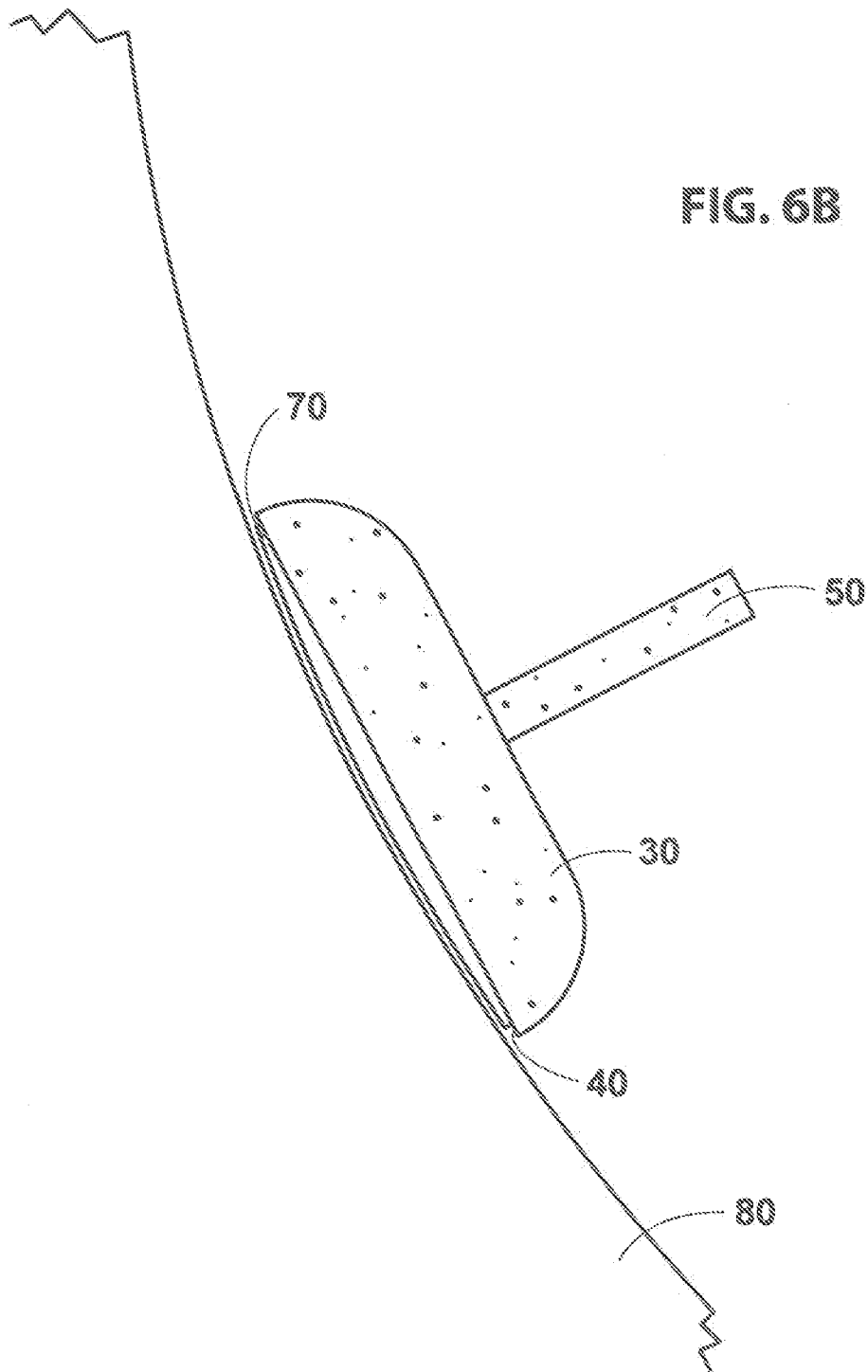
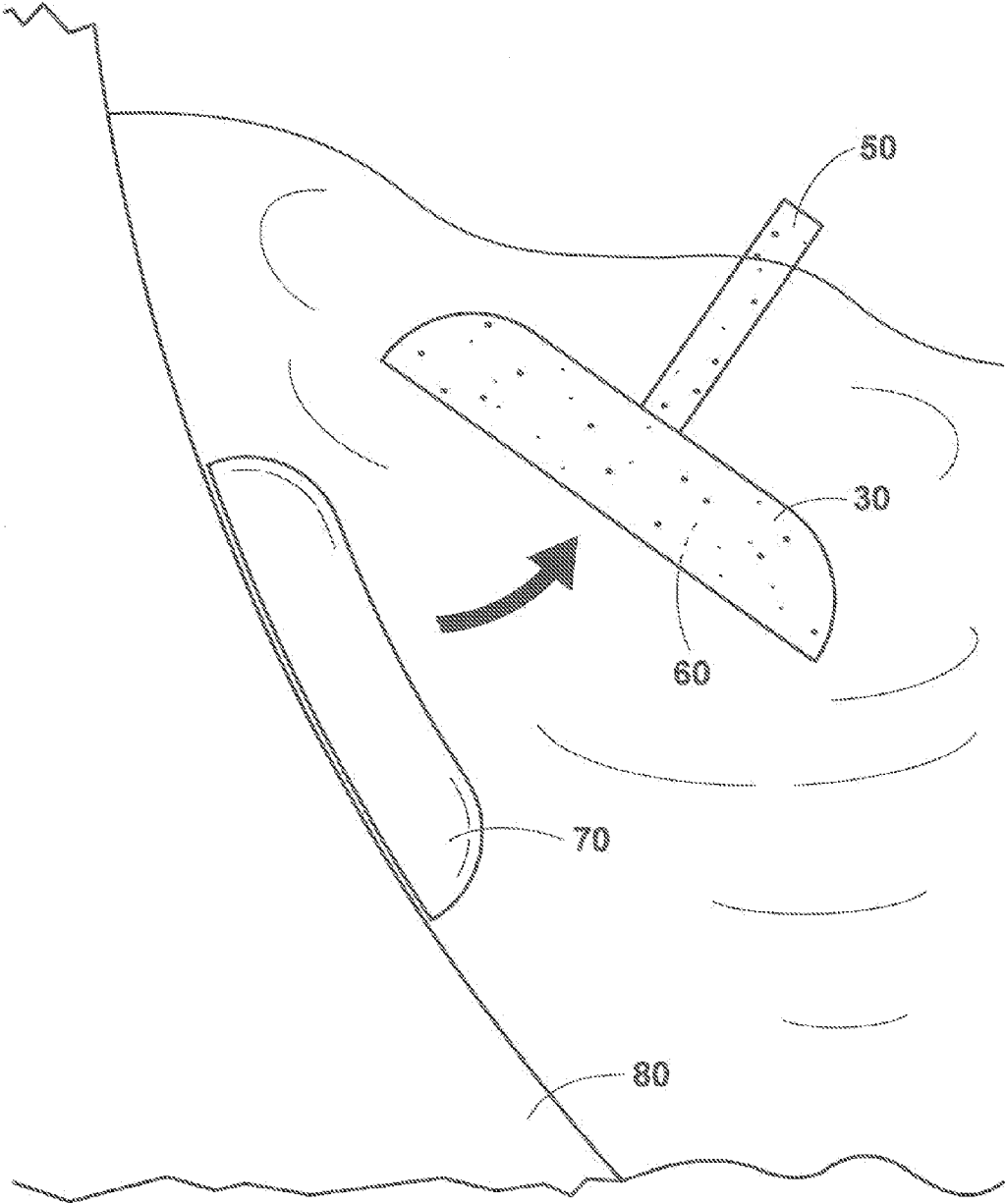

FIG. 6C





## DISSOLVABLE UNIT DOSE APPLICATOR FOR CLEANING SUBSTANCES

### TECHNICAL FIELD

[0001] Embodiments herein relate to methods, systems, and apparatuses for applying a cleaning substance to a bathroom surface.

### BACKGROUND

[0002] Cleaning/deodorizing compositions for use in toilets are available in several forms. Sprays and liquids are typically applied directly to an interior surface of the toilet bowl to aid mechanical cleaning (i.e., with a toilet brush or sponge). However, these cleaners require the use of a toilet brush or other means for mechanically removing surface debris.

[0003] Solid and semi-solid formulations are also available for use in toilets. Some pucks may be dropped into the tank portion of the toilet to release bleach, cleaners, disinfectants, and/or fragrances into the water each time the toilet bowl is refilled after flushing. Others may be suspended within the toilet bowl, such as below the upper rim of the bowl. In order to use these products, however, a user must remove the lid of the tank or mechanically attach and subsequently remove a hook or other suspension means from inside the toilet bowl. In addition, the amount of cleaner or deodorizer released may vary dramatically throughout the useful life of the product.

[0004] More recently, semi-solid cleaners such as gels have become available for use in toilet bowls. A multi-use, disposable dispenser is pre-filled with multiple adhesive gel discs and used to stamp an adhesive gel disc onto an interior surface of the toilet bowl. The gel disc adheres to the surface and gradually dissolves over a period of several days, at which time the same dispenser may be used again to stamp a new adhesive gel disc onto the interior surface of the toilet bowl. The dispenser typically requires assembly by the user. Incorrect assembly or use may cause the adhesive gel to be dispensed in greater than desired volumes. Further, the user must re-cap the end of the dispenser that has contacted the inside of the toilet bowl and store the dispenser for future use of the remaining adhesive gel discs. Such re-use of the soiled dispenser compromises sanitation and increases the risk of spreading and/or transmitting infectious bacteria. Finally, when all of the gel discs have been used, the dispenser must be disposed. Because few such dispensers are recycled, and are often not biodegradable, they typically end up at landfills, where they will remain in a non-decomposed state.

### SUMMARY

[0005] Embodiments provide an apparatus for applying a cleaning substance to a bathroom surface to be cleaned, the apparatus comprising a body that is dissolvable in water, the body having an elongate, distally-facing wall defining a cavity for releasably retaining the cleaning substance until the body is dislodged by flowing water.

[0006] Another embodiment provides an apparatus for applying a cleaning substance to a toilet surface to be cleaned. The apparatus includes the cleaning substance for cleaning the toilet surface and a body that is dissolvable in water. The body has a distally-facing cavity for releasably retaining the cleaning substance and a proximally-extending gripping mechanism to permit the user to grip the body and then press the cleaning substance against the toilet surface. The body is

configured to release the cleaning substance to permit fee body to be dislodged by flowing water.

[0007] Another embodiment provides a method for applying a cleaning substance to a toilet bowl. The method includes the following steps: selecting a body that is dissolvable in water, the body defining a distally-facing cavity that removably retains the cleaning substance, and having a distally-disposed terminal edge and a proximally-extending gripping mechanism; pressing the cleaning substance against the toilet bowl using the gripping mechanism, to apply the cleaning substance to the toilet bowl; and removing the body such that the cleaning substance is left on the toilet bowl.

### BRIEF DESCRIPTION OF THE DRAWINGS

[0008] Subject matter is particularly pointed out and distinctly claimed in the concluding portion of the specification. The foregoing and other features of the present disclosure will become more fully apparent from the following description and appended claims, taken in conjunction with the accompanying drawings. Understanding that these drawings depict only several embodiments in accordance with the disclosure and are, therefore, not to be considered limiting of its scope, the disclosure will be described with additional specificity and detail through use of the accompanying drawings, in which:

[0009] FIG. 1 is a perspective view of a first embodiment of a dissolvable apparatus for applying a substance to a surface in accordance with the present invention.

[0010] FIG. 2 is a top elevational view of the apparatus depicted in FIG. 1.

[0011] FIG. 3 is a bottom elevational view of the apparatus depicted in FIG. 1.

[0012] FIG. 4 is a cross-sectional view of the apparatus depicted in FIG. 1, taken at 4-4 of FIG. 2.

[0013] FIG. 5 is an exploded view of the apparatus depicted in FIG. 1 containing a substance to be applied to a surface.

[0014] FIG. 6A is a front elevational view of the apparatus depicted in FIG. 1 prior to application.

[0015] FIG. 6B is a front elevational view of the apparatus depicted in FIG. 1 during and after application.

[0016] FIG. 6C is a front elevational view of the apparatus depicted in FIG. 1 after flowing water dislodges the apparatus from the substance.

### DETAILED DESCRIPTION OF DISCLOSED EMBODIMENTS

[0017] In the following detailed description, reference is made to the accompanying drawings which form a part hereof, and in which are shown by way of illustration embodiments that may be practiced. It is to be understood that other embodiments may be utilized and structural or logical changes may be made without departing from the scope. Therefore, the following detailed description is not to be taken in a limiting sense, and the scope of embodiments is defined by the appended claims and their equivalents.

[0018] Various operations may be described as multiple discrete operations in turn, in a manner that may be helpful in understanding embodiments; however, the order of description should not be construed to imply that these operations are order dependent.

[0019] The description may use perspective-based descriptions such as up/down, back/front, and top/bottom. Such

descriptions are merely used to facilitate the discussion and are not intended to restrict the application of disclosed embodiments.

**[0020]** The terms “coupled” and “connected,” along with their derivatives, may be used. It should be understood that these terms are not intended as synonyms for each other. Rather, in particular embodiments, “connected” maybe used to indicate that two or more elements are in direct physical or electrical contact with each other. “Coupled” may mean that two or more elements are in direct physical or electrical contact. However, “coupled” may also mean that two or more elements are not in direct contact with each other, but yet still cooperate or interact with each other.

**[0021]** Reference is made to the drawings wherein like numerals refer to like parts throughout. For ease of description, the components of embodiments of the present disclosure are described in the normal (upright) operating position, and terms such as upper, lower, horizontal, etc., are used with reference to this position. It will be understood, however, that the components of embodiments of the present disclosure may be manufactured, stored, transported, used, and sold in an orientation other than the position described.

**[0022]** Figures illustrating the components of embodiments of the present disclosure show some conventional mechanical elements that may be known and that may be recognized by one skilled in the art. Detailed descriptions of such elements are not necessary to an understanding of the disclosure and accordingly are herein presented only to the degree necessary to facilitate an understanding of the novel features of the present disclosure.

**[0023]** As used herein and in the appended claims, the term “comprising” is inclusive or open-ended and does not exclude additional unrecited elements, compositional components, or method steps. Accordingly, the term “comprising” encompasses the more restrictive terms “consisting essentially of” and “consisting of.”

**[0024]** It must be noted that, as used in this specification and the appended claims, the singular forms “a,” “an,” and “the” include plural references unless the content clearly dictates otherwise. Similarly, the use of substantially any plural terms herein may be translated by those having skill in the art from the plural to the singular as is appropriate to the context and/or application. The various singular/plural permutations may be expressly set forth herein for sake of clarity.

**[0025]** In those instances where a convention analogous to “at least one of A, B, and C, etc.” is used, in general such a construction is intended in the sense one having skill in the art would understand the convention (e.g., “an apparatus having at least one of A, B, and C” would include but not be limited to apparatuses that have A alone, B alone, C alone, A and B together, A and C together, B and C together, and/or A, B, and C together, etc). It will be further understood by those within the art that virtually any disjunctive word and/or phrase presenting two or more alternative terms, whether in the description, claims, or drawings, should be understood to contemplate the possibilities of including one of the terms, either of the terms, or both terms. For example, the phrase “A or B” will be understood to include the possibilities of “A” or “B” or “A and B.”

**[0026]** The description may use the terms “embodiment” or “embodiments,” which may each refer to one or more of the same or different embodiments. Furthermore, the terms “comprising,” “including,” “having,” and the like, as used with respect to embodiments, are synonymous.

**[0027]** Unless defined otherwise, all technical and scientific terms used herein have the same meaning as commonly understood by one of ordinary skill in the art to which embodiments of the present invention pertain. Although a number of methods and materials similar or equivalent to those described herein can be used in the practice of the present invention, the preferred materials and methods are described herein.

**[0028]** The term “cleaning substance” as used herein, refers to any cleansing, deodorizing, disinfecting, and/or fragranting substance configured to adhere to a non-horizontal surface (e.g., a porous or non-porous surface comprising a plastic/polymer, ceramic, metal, glass, or stone surface) and remain substantially in place, without the aid of a separate supporting structure or mechanism, until at least partially dissolved, dissipated, or otherwise removed (e.g., by disintegration, sublimation, or mechanical force). Cleaning substances may be composed of one or more cleaning agents (e.g., surfactants, detergents), alkalis, oxidizers, petrochemicals, oleochemicals, emulsifiers, thickeners, enzymes, antimicrobials, fragrances, dyes, preservatives, fillers, and/or stabilizers. Cleaning substances may take on any solid or semi-solid form, such as but not limited to gels, pastes, waxes, and other solids or semi-solids.

**[0029]** Cleaning substances as contemplated in the present invention may be formed by one or more known manufacturing methods, such as melting and casting, extrusion, and/or compression, alone or in any combination. For example, a cleaning substance may be cast or compressed within, or extruded into, the cavity of an applicator in accordance with the claimed invention during the manufacturing process. Alternatively, the cleaning substance may be extruded in a log or other shape into the cavity of the applicator and severed at or near the edge of the cavity opening with a cutting device. As another alternative, the cleaning substance may be formed as a solid insert in a separate process and subsequently inserted into the cavity of the applicator (e.g., during the manufacturing process or by the end user prior to use). Accordingly, the cleaning substance and applicator may be supplied as separate components. While crescent or dome-shaped cleaning substances are described herein by way of example because such smooth, symmetrical shapes encourage even dissolution or dissipation of the cleaning substance, any variety of shapes may be used, such as but not limited to stars, flowers, fruits, rings, paw prints, and geometric designs.

**[0030]** The dissolvable or flushable applicator described herein may be composed of a variety of chemicals and formed by a variety of manufacturing methods. A suitable chemical composition may include, for example, a mixture containing one or more dry organic acids/salts, bases, and binders. Suitable dry organic acids/salts include but are not limited to citric acid, oxalic acid, sodium citrate, calcium citrate, potassium hydrogen tartrate, sodium acid pyrophosphate, or magnesium sulfate. Suitable bases include but are not limited to sodium bicarbonate or potassium, bicarbonate. Suitable binders include but are not limited to corn starch, witch hazel, or water soluble adhesives. Other chemicals that may be added to the mixture include but are not limited to dry surfactants and processing aides (e.g., borax). Once combined and conglomerated, applicators may be formed using the mixture using one or more known manufacturing methods, such as extrusion, compaction, compression, briquetting, and/or tableting, alone or in any combination.

**[0031]** Surfaces to which substances described herein may be applied include but are not limited to surfaces generally found in bathrooms, such as toilet bowls, sinks, bathtubs, bathtub walls, shower walls, and the like.

**[0032]** FIGS. 1-6 depict an embodiment of the present invention. FIG. 1 is an enlarged perspective view of a dissolvable or flushable apparatus 10 for applying a cleaning substance to a bathroom surface in accordance with the claimed invention. FIGS. 2-3 are top and bottom elevational views of apparatus 10, respectively. FIG. 4 is a cross-sectional view of apparatus 10 taken along line 4-4 of FIG. 2. FIG. 5 is an exploded view of apparatus 10 containing a cleaning substance. FIGS. 6A-C are front elevational views of apparatus 10 containing the cleaning substance prior to application to the surface, during and after application, and after flowing water dislodges apparatus 10 from the cleaning substance, respectively.

**[0033]** Referring to FIGS. 1-3, apparatus 10 comprises a flushable or dissolvable body 20 having a distally-extending wall 30, a distally-disposed terminal edge 40, and a proximally-extending gripping mechanism 50. As best shown in FIG. 5, wall 30 defines a cavity 60 for releasably retaining a cleaning substance 70. Gripping mechanism 50 proximally extends from body 20 to provide a surface onto which a user may grip the apparatus. Gripping mechanism 50 also provides a surface against which water may flow, thereby facilitating the release of cleaning substance 70 from cavity 60. It will be understood that apparatus 10 may include a single gripping mechanism, a plurality of gapping mechanism, or none at all. Moreover, gripping mechanism 50 may take on a variety of shapes and sizes, including but not limited to, nubs, tabs, wings, stems, and/or other surface textures.

**[0034]** Apparatus 10 may include other means for facilitating the release of cleaning substance 70 from cavity 60. In some examples (not shown here), a releasing agent or material composed of, for example, a "hydrophobic" substance is applied to at least a portion of wall 30 adjacent cavity 60 to further aid the release of cleaning substance 70 from cavity 60. Alternatively, a barrier material might be applied to the wall in order to prevent cleaning substance 70 from degrading wall 30.

**[0035]** In operation, as depicted in FIG. 6A, cavity 60 retains cleaning substance 70 prior to application to a bathroom surface to be cleaned 90. The apparatus is extended in the direction of bathroom surface 80. As shown in FIG. 6B, cleaning substance 70 makes contact with bathroom surface 80 and adheres. Additional force may be applied to gripping mechanism 50 to force terminal edge 40 against bathroom surface 80 to reinforce contact and adhesion between cleaning substance 70 and bathroom surface 80. Also shown in FIG. 6B, after contact and adhesion have been made between cleaning substance 70 and bathroom surface 80, apparatus 10 containing cleaning substance 70 is left on the side of bathroom surface 80. Finally, as shown in FIG. 6C, apparatus 10 encounters flowing water and is dislodged from cleaning substance 70. Thereafter, apparatus 10 may dissolve in the flowing water or be flushed away. In alternative embodiments, apparatus 10 may be manually removed by a user after application and discarded in water to dissolve or be flushed away.

**[0036]** In other embodiments not shown here, apparatus 10 may include one or a combination of surface features to improve a user's grip on wall 30 or gripping mechanism 50. Some surface features, particularly those positioned on the

outer surface of gripping mechanism 50, may provide visual cues to a user, allowing the user to easily determine the proper operation of the apparatus without consulting instructional manuals or written directions. Such surface features include but are not limited to apertures, or raised ridges or pads configured to substantially conform to the shape and size of a user's finger pad. Such surface features provide visual cues to a user to place his or her thumb and index finger at the position of the surface feature.

**[0037]** The depicted embodiments illustrate an apparatus that is supplied as a dissolvable or flushable single-use applicator that is pre-filled with a unit dose of cleaning substance to be applied. Once the applicator has been used to dispense the cleaning substance onto the desired surface, the applicator (still containing the cleaning substance) may be left on the surface until it is dislodged by flowing water or manually removed by the user. In some examples (not shown here), the cavity of the applicator is coated with a chemical, and removal of the applicator releases a burst of fragrance or cleaning agent into the flowing water. In other examples (not shown here), the open end of the cavity proximate the terminal edge may be sealed with a removable feature that is pulled away from the applicator and discarded prior to application. Such removable features protect the cleaning substance during packaging and shipping and ensure optimal freshness and/or adhesion upon application. Examples of such removable features include, but are not limited to, induction seals, heat sealed films, injection molded covers, and trays that protect the substance contained in multiple applicators.

**[0038]** Although certain embodiments have been illustrated and described herein, it will be appreciated by those of ordinary skill in the art that a wide variety of alternate and/or equivalent embodiments or implementations calculated to achieve the same purposes may be substituted for the embodiments shown and described without departing from the scope. Those with skill in the art will readily appreciate that embodiments may be implemented in a very wide variety of ways. This application is intended to cover any adaptations or variations of the embodiments discussed herein. Therefore, it is manifestly intended that embodiments be limited only by the claims and the equivalents thereof.

What is claimed:

1. An apparatus for applying a cleaning substance to a bathroom surface to be cleaned, the apparatus comprising a body that is dissolvable in water, the body having an elongate, distally-facing wall defining a cavity for releasably retaining the cleaning substance until the body is dislodged by flowing water.

2. The apparatus of claim 1, further comprising a releasing agent applied to the distally-facing wall of the body for facilitating the dislodging of the body, and thereby the release of the cleaning substance from the cavity.

3. The apparatus of claim 1, wherein the body further comprises a distally-disposed terminal edge that is adapted to be pressed against the surface to facilitate application of the cleaning substance to the bathroom surface.

4. The apparatus of claim 1, wherein the body further comprises a proximally-extending gripping mechanism to permit the user to grip the body and press the cleaning substance against the bathroom surface.

5. The apparatus of claim 4, wherein the proximally-extending gripping mechanism comprises a flat, broad portion adapted to facilitate the dislodging of the body, and thereby the release of the cleaning substance from the cavity.

6. An apparatus for applying a cleaning substance to a toilet surface to be cleaned, comprising:

a cleaning substance for cleaning the toilet surface; and  
a body that is dissolvable in water, the body defining a distally-facing cavity for releasably retaining the cleaning substance, the body having a proximally-extending gripping mechanism to permit the user to grip the body and then press the cleaning substance against the toilet surface, wherein the body is configured to release the cleaning substance to permit the body to be dislodged by flowing water.

7. The apparatus of claim 6, further comprising a releasing material that is disposed on a distally-facing surface of the body between the cleaning substance and the body to facilitate the release of the cleaning substance from the body.

8. The apparatus of claim 6, wherein the body further comprises a distally-disposed terminal edge that is adapted to be pressed against the toilet surface to facilitate application of the cleaning substance to the toilet surface.

9. The apparatus of claim 6, wherein the proximally-extending gripping mechanism comprises a single protruding

member adapted to facilitate the dislodging of the body, and thereby the release of the cleaning substance from the body.

10. A method for applying a cleaning substance to a toilet bowl, the method comprising:

selecting a body that is dissolvable in water, the body defining a distally-facing cavity that removably retains the cleaning substance, and having a distally-disposed terminal edge and a proximally-extending gripping mechanism;

pressing the cleaning substance against the toilet bowl using the gripping mechanism, to apply the cleaning substance to the toilet bowl; and

removing the body such that the cleaning substance is left on the toilet bowl.

11. The method of claim 10 wherein the step of removing the body comprises manually removing the body from the cleaning substance.

12. The method of claim 10 wherein the step of removing the body comprises permitting the body to be removed from the cleaning substance by water acting on the body as the toilet is flushed.

\* \* \* \* \*