



(19) **United States**

(12) **Patent Application Publication**
Robles et al.

(10) **Pub. No.: US 2014/0135724 A1**
(43) **Pub. Date: May 15, 2014**

(54) **DISPOSABLE WEARABLE ABSORBENT ARTICLES WITH MULTIPLE INDICATING COLORS**

continuation-in-part of application No. 12/346,445, filed on Dec. 30, 2008, now abandoned.

Publication Classification

- (71) Applicant: **The Procter & Gamble Company**, Cincinnati, OH (US)
- (72) Inventors: **Miguel Alvaro Robles**, Wyoming, OH (US); **Mattias Schmidt**, Idstein (DE); **Kuang-Kai Liu**, Cincinnati, OH (US); **Donald Carroll Roe**, West Chester, OH (US)
- (73) Assignee: **The Procter & Gamble Company**, Cincinnati, OH (US)
- (21) Appl. No.: **14/160,621**
- (22) Filed: **Jan. 22, 2014**

- (51) **Int. Cl.**
A61F 13/42 (2006.01)
- (52) **U.S. Cl.**
CPC *A61F 13/42* (2013.01)
USPC **604/361**

(57) **ABSTRACT**

A disposable wearable absorbent article comprises a top-sheet, an absorbent core, an outer cover, a waist opening, leg openings, a first visual fullness indicating area, and a second visual fullness indicating area. The first visual fullness indicating area is configured to change to a first subsequent color when indicating the presence of a bodily exudate. The second visual fullness indicating area is configured to change to a second subsequent color when indicating the presence of a bodily exudate. The second subsequent color is visually distinguishable from the first subsequent color. At least a portion of each of the visual fullness indicating areas is visible from outside of the disposable wearable absorbent article when the article is worn by a wearer.

Related U.S. Application Data

- (63) Continuation of application No. 12/646,296, filed on Dec. 23, 2009, now Pat. No. 8,674,168, which is a

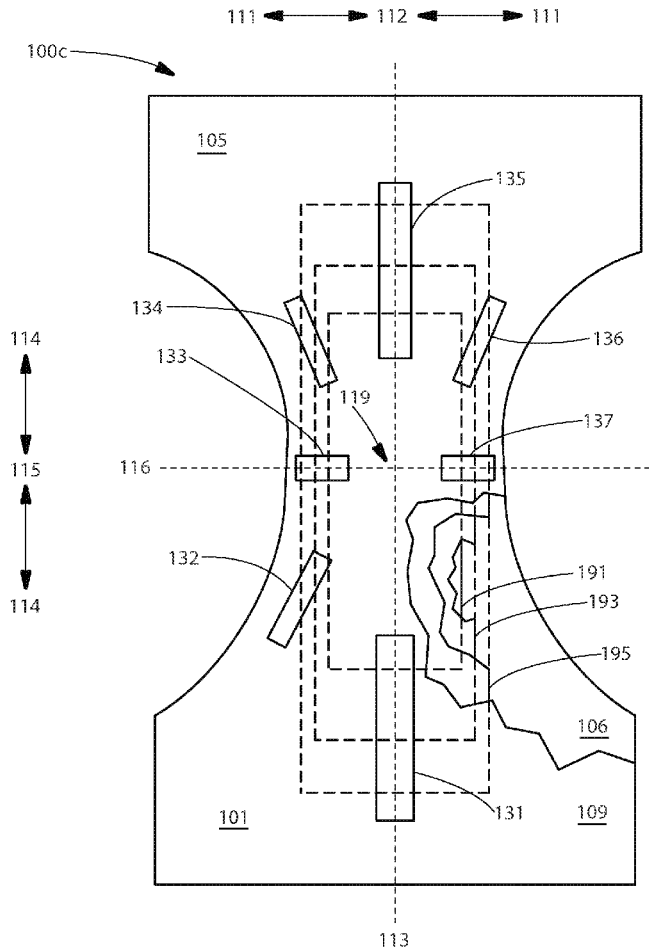

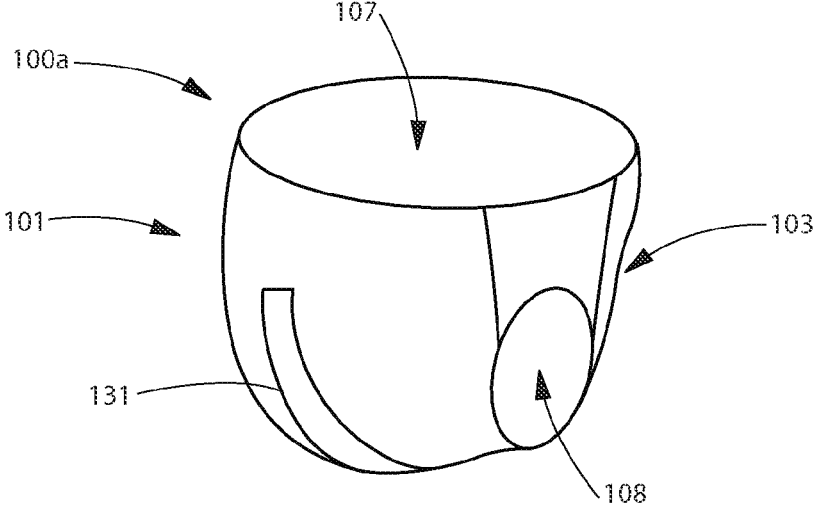

Fig. 1A

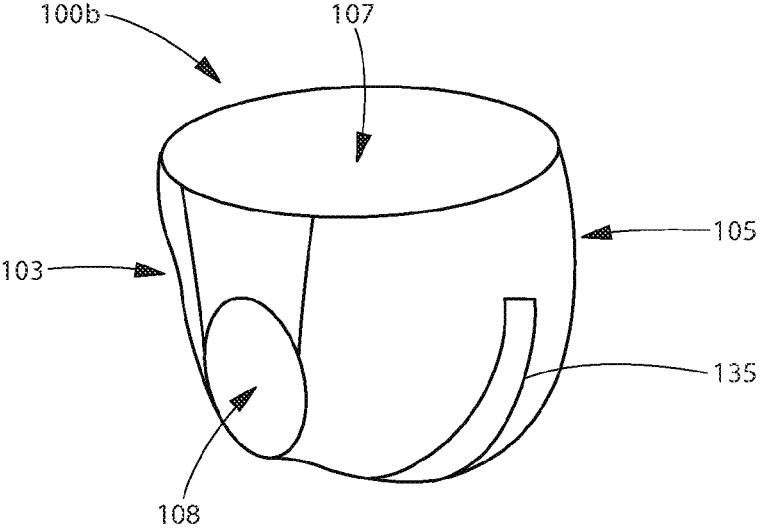

Fig. 1B

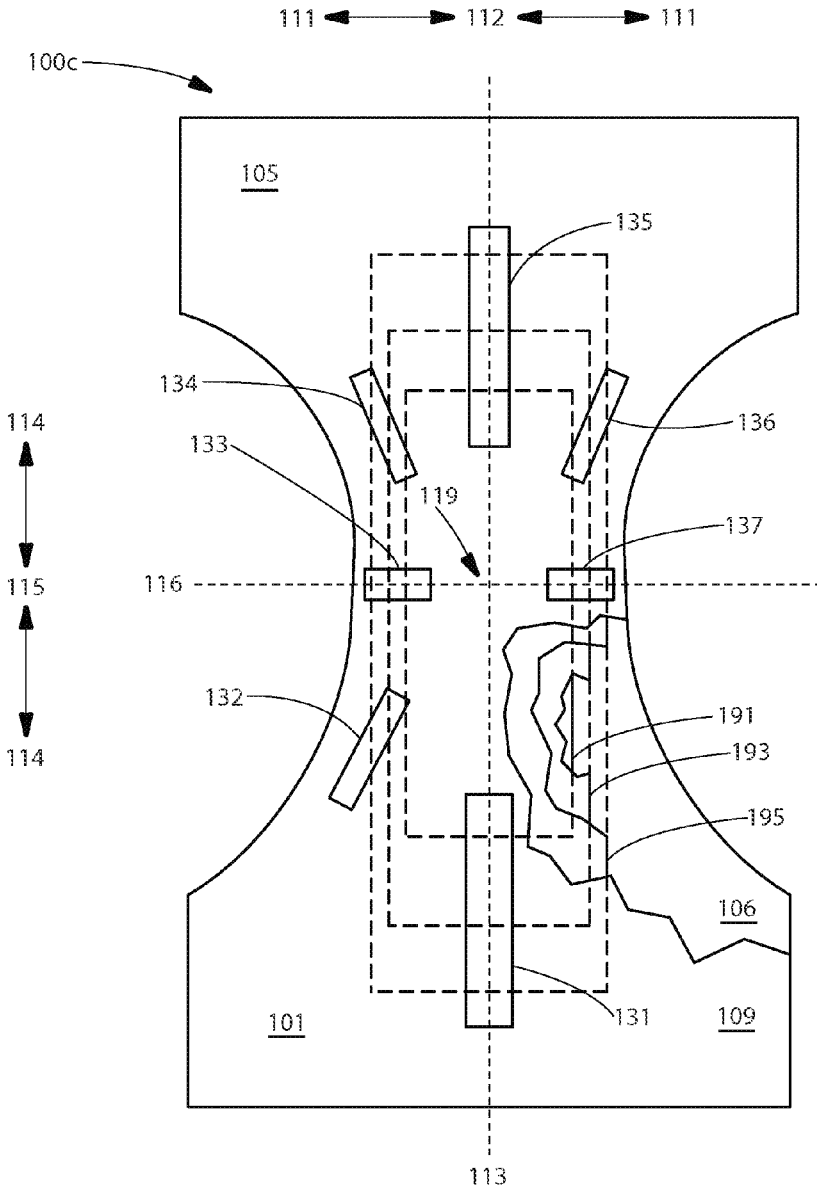

Fig. 1C

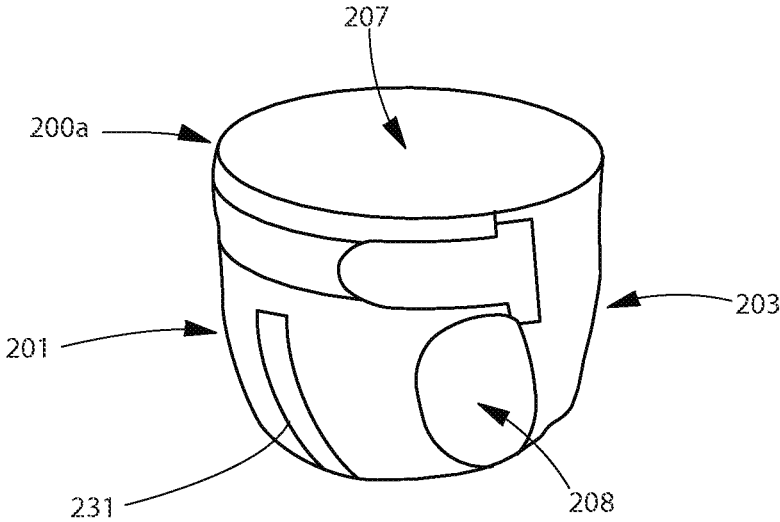

Fig. 2A

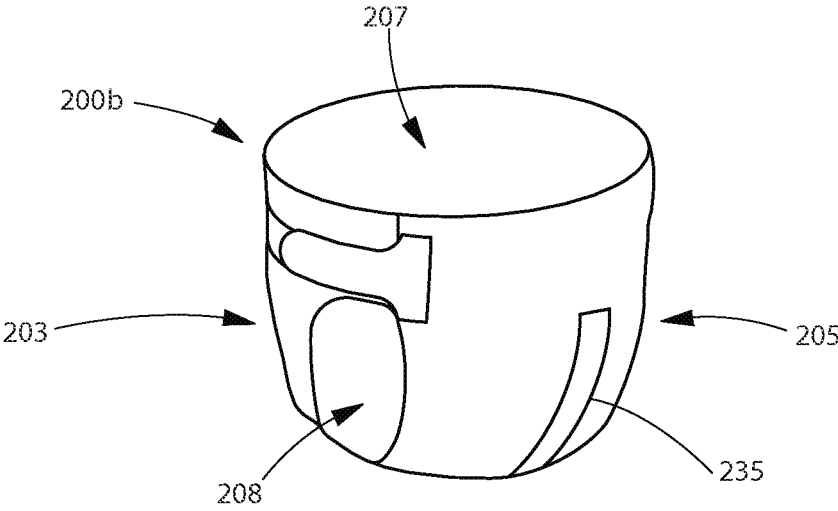

Fig. 2B

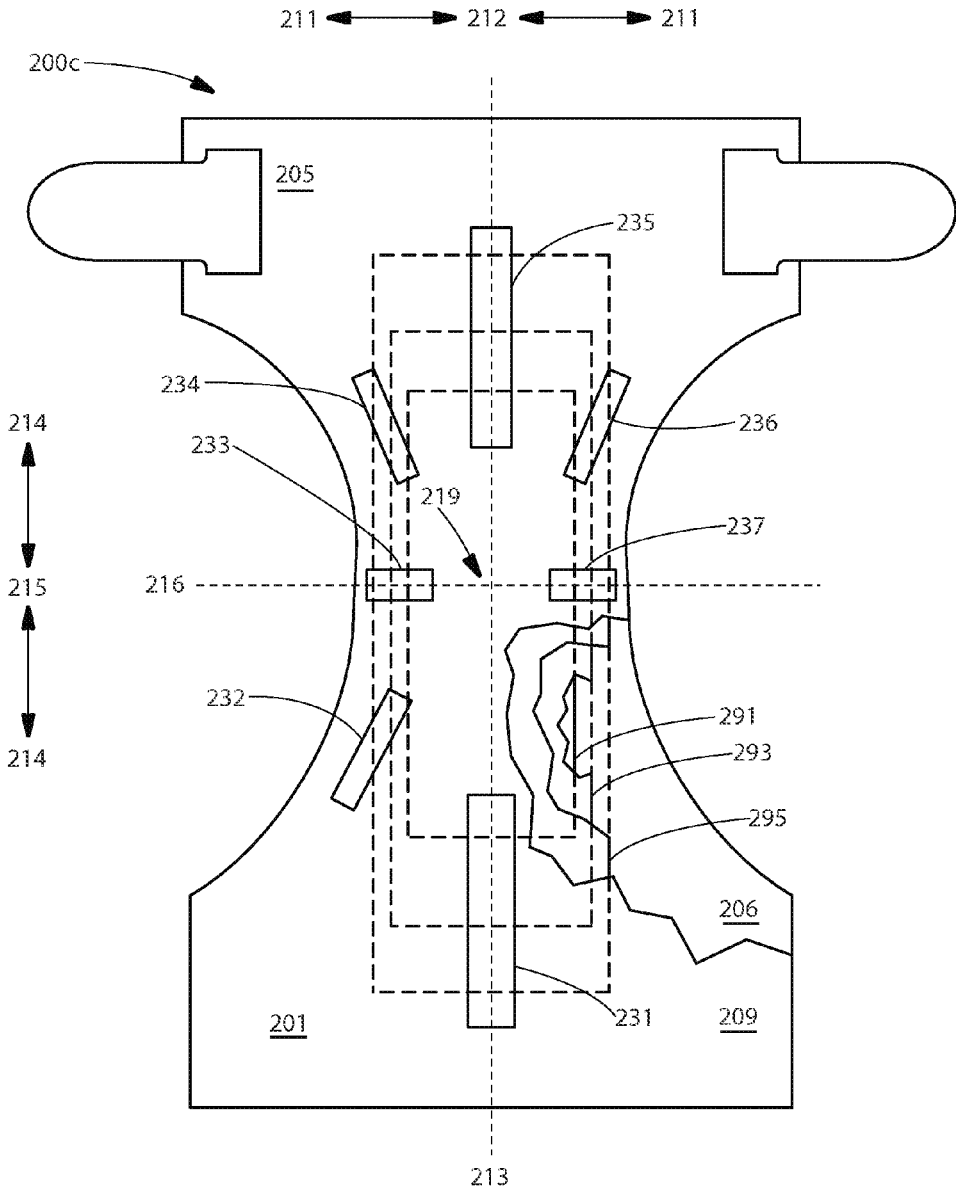

Fig. 2C

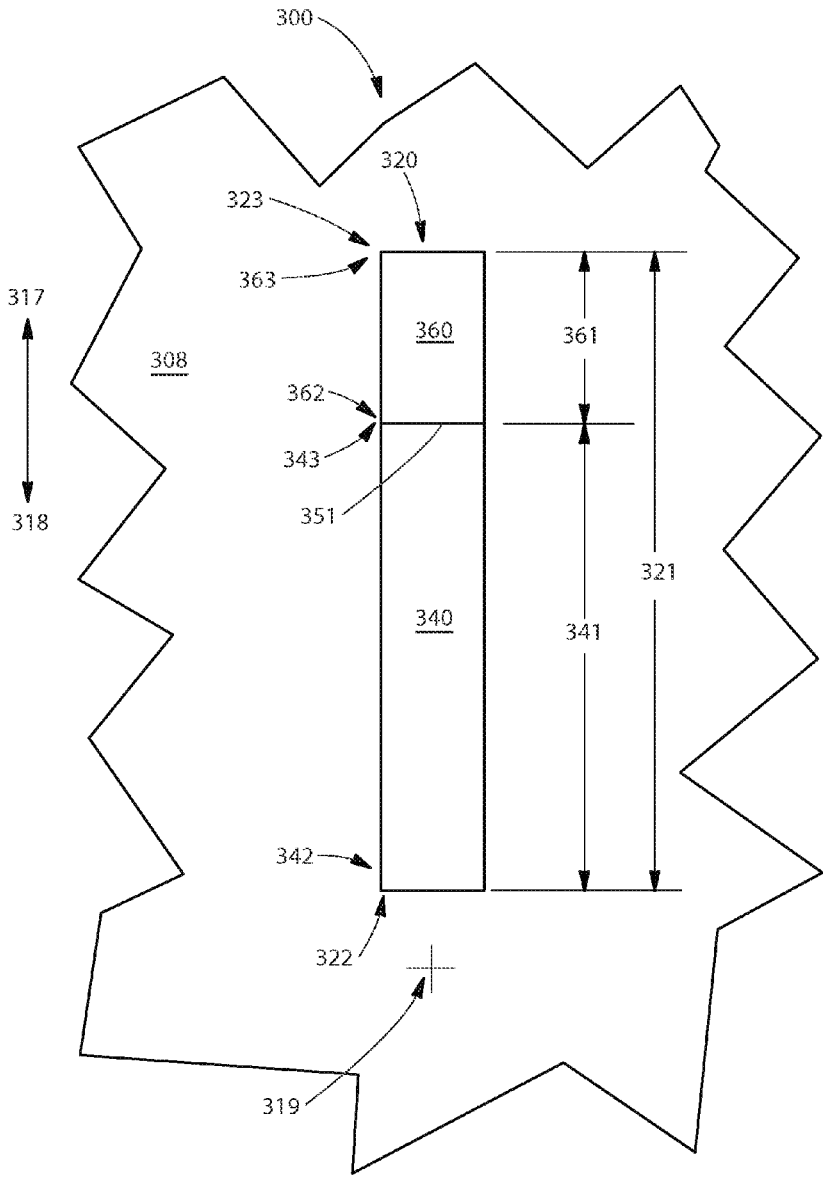

Fig. 3A

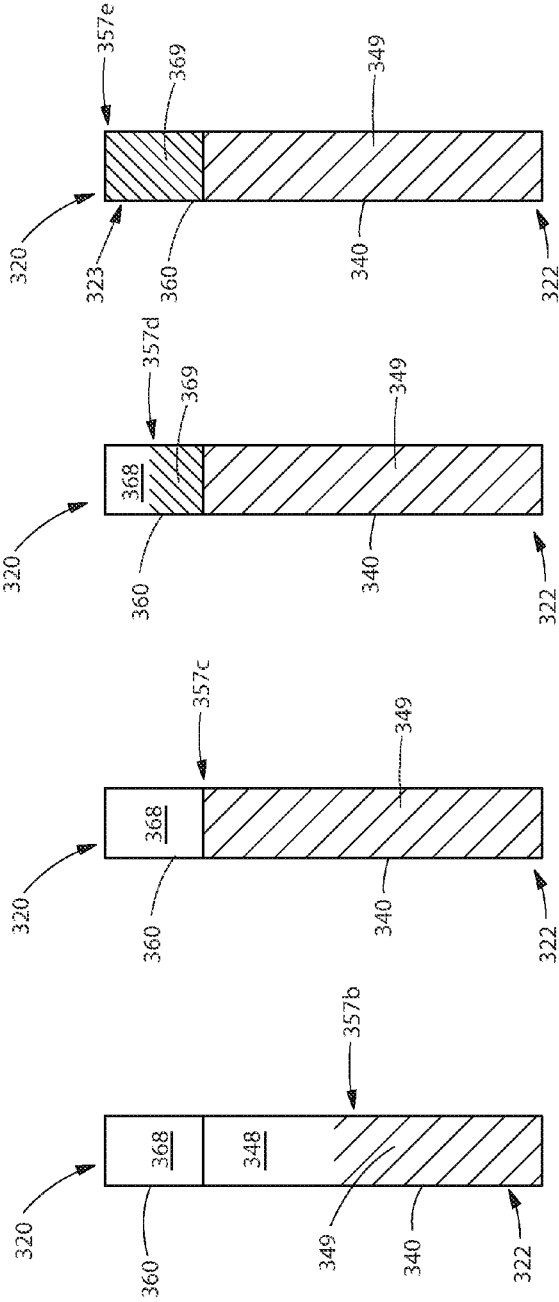

Fig. 3B

Fig. 3C

Fig. 3D

Fig. 3E

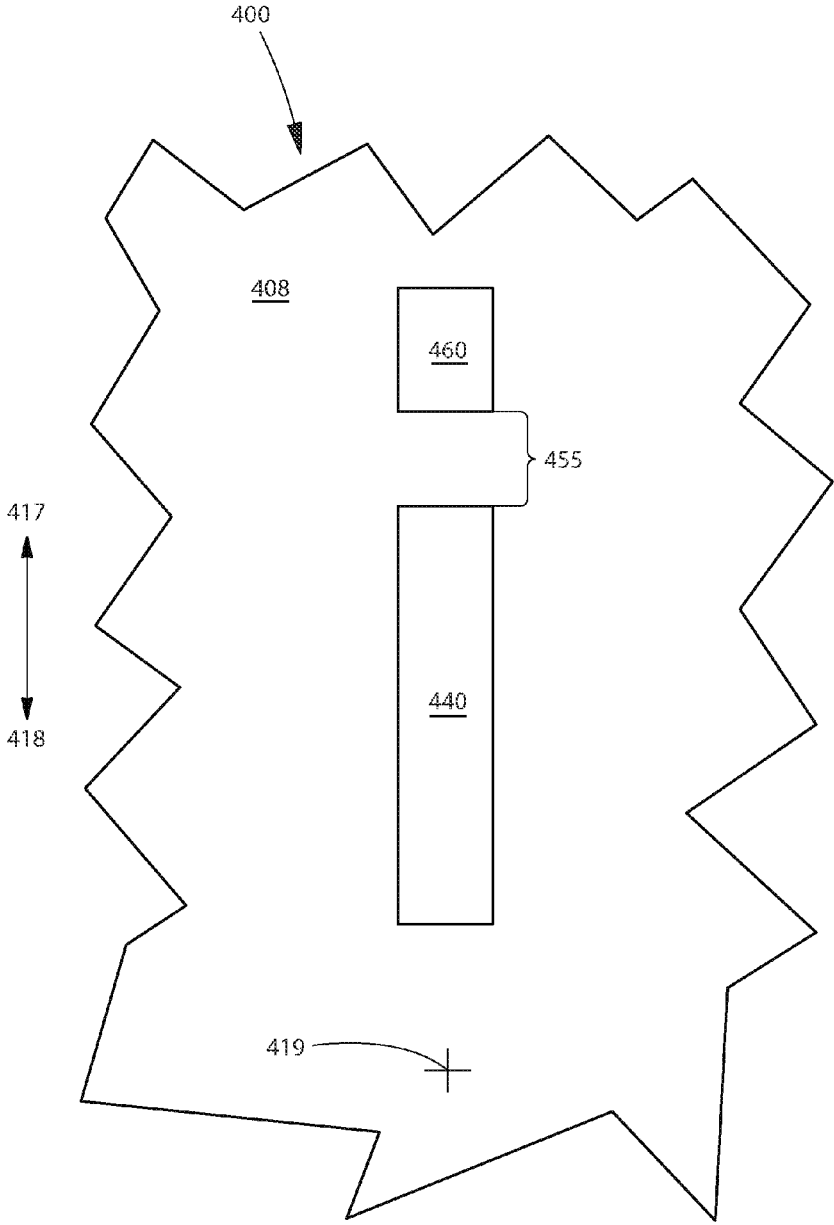

Fig. 4

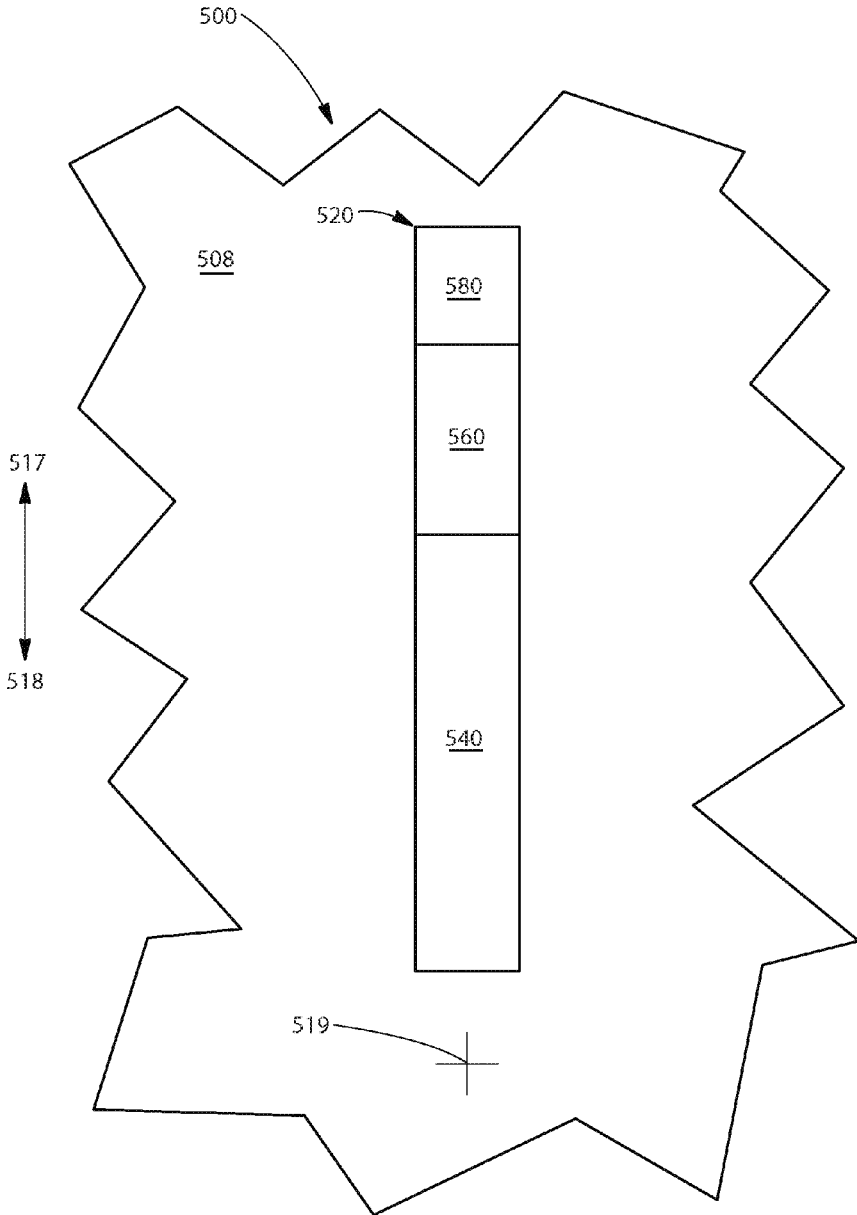

Fig. 5

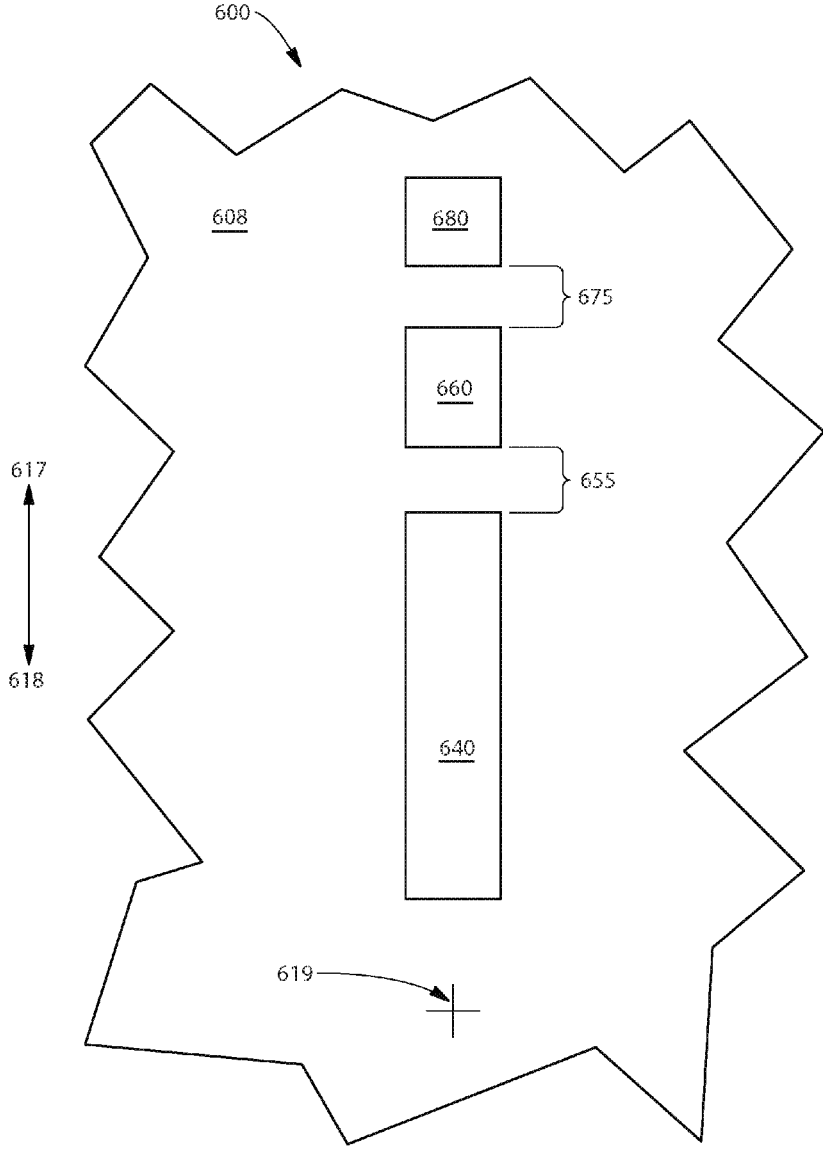

Fig. 6

DISPOSABLE WEARABLE ABSORBENT ARTICLES WITH MULTIPLE INDICATING COLORS

FIELD

[0001] In general, embodiments of the present disclosure relate to wetness indicating for absorbent articles. In particular, embodiments of the present disclosure relate to visual fullness indicating for disposable wearable absorbent articles.

BACKGROUND

[0002] Absorbent articles can absorb liquid bodily exudates such as sweat, blood, urine, menses, etc. An absorbent article can include a wetness indicator. The wetness indicator can indicate the presence of a liquid bodily exudate in the article. Unfortunately, some wetness indicators for absorbent articles can be difficult to understand. If the signal from a wetness indicator is misunderstood then the absorbent article may be changed too soon. The wearer may underutilize the capacity of the article. If the signal from a wetness indicator is misunderstood then the absorbent article may be changed too late. The bodily exudates may exceed the capacity of the article resulting in leaks.

BRIEF DESCRIPTION OF THE DRAWINGS

[0003] FIG. 1A illustrates a pant-type disposable wearable absorbent article with a visual fullness indicator in the front, according to embodiments of the present disclosure.

[0004] FIG. 1B illustrates a pant-type disposable wearable absorbent article with a visual fullness indicator in the back, according to embodiments of the present disclosure.

[0005] FIG. 1C illustrates a pant-type disposable wearable absorbent article with a number of visual fullness indicators, according to embodiments of the present disclosure.

[0006] FIG. 2A illustrates a front-fastenable disposable wearable absorbent article with a visual fullness indicator in the front, according to embodiments of the present disclosure.

[0007] FIG. 2B illustrates a front-fastenable disposable wearable absorbent article with a visual fullness indicator in the back, according to embodiments of the present disclosure.

[0008] FIG. 2C illustrates a front-fastenable disposable wearable absorbent article with a number of visual fullness indicators, according to embodiments of the present disclosure.

[0009] FIG. 3A illustrates a portion of an absorbent article with a visual fullness indicator having a first visual fullness indicating area and a second visual fullness indicating area configured to change to visually distinguishable subsequent indicating colors, according to embodiments of the present disclosure.

[0010] FIG. 3B illustrates a subsequent state of indication for the visual fullness indicator of FIG. 3A, according to embodiments of the present disclosure.

[0011] FIG. 3C illustrates a subsequent state of indication for the visual fullness indicator of FIG. 3B, according to embodiments of the present disclosure.

[0012] FIG. 3D illustrates a subsequent state of indication for the visual fullness indicator of FIG. 3C, according to embodiments of the present disclosure.

[0013] FIG. 3E illustrates a subsequent state of indication for the visual fullness indicator of FIG. 3D, according to embodiments of the present disclosure.

[0014] FIG. 4 illustrates a portion of an absorbent article with a visual fullness indicator having a first visual fullness indicating area and a second visual fullness indicating area configured to change to visually distinguishable subsequent indicating colors, wherein the first visual fullness indicating area is spaced apart from the second visual fullness indicating area, according to embodiments of the present disclosure.

[0015] FIG. 5 illustrates a portion of an absorbent article with a visual fullness indicator having a first visual fullness indicating area, a second visual fullness indicating area, and a third visual fullness indicating area, configured to change to visually distinguishable subsequent indicating colors, according to embodiments of the present disclosure.

[0016] FIG. 6 illustrates a portion of an absorbent article with a visual fullness indicator having a first visual fullness indicating area, a second visual fullness indicating area, and a third visual fullness indicating area configured to change to visually distinguishable subsequent indicating colors, wherein the first visual fullness indicating area, the second visual fullness indicating area, and the third visual fullness indicating area are spaced apart from each other, according to embodiments of the present disclosure.

SUMMARY

[0017] The present disclosure includes absorbent articles with wetness indicators that are easy to understand. The wetness indicators are easy to understand because they have multiple colors.

[0018] As an example, an absorbent article can have a first visual fullness indicating area that changes to green, a second visual fullness indicating area that changes to yellow, and a third visual fullness indicating area that changes to red. The visual fullness indicating areas can be configured to change colors in sequence; first green, then yellow, then red.

[0019] Each color can indicate how full the absorbent article is. For instance, the green color can indicate that the absorbent article is somewhat filled, the yellow color can indicate that the absorbent article is approaching full, and the red color can indicate that the absorbent article is full. These different colors can provide differing visual signals. These differing visual signals can be easily understood as indicating differing degrees of fullness.

[0020] An absorbent article having multiple indicating colors can help provide certainty about the fullness of the absorbent article. By knowing how full an article is, the article can be changed after the wearer has appropriately utilized the capacity of the article. Also, by knowing how full an article is, the article can be changed before it is likely to leak.

DETAILED DESCRIPTION

[0021] The multiple indicating colors of the present disclosure can be used with all kinds of absorbent articles. An absorbent article can absorb liquid bodily exudates such as sweat, blood, urine, menses, etc. An absorbent article can be a product or a material. Examples of absorbent articles include products and/or materials for sanitary protection, hygienic use, and/or wound care.

[0022] Some absorbent articles are disposable. A disposable absorbent article is configured to be partly or wholly disposed of after a single use. A disposable absorbent article is configured such that the soiled article, or a soiled portion of the article, is not intended to be restored and reused (e.g., not intended to be laundered). Examples of disposable absorbent

articles include wound care products, such as bandages and dressings, as well as feminine care products, such as pads and liners. Disposable absorbent articles can use embodiments of the present disclosure.

[0023] Some absorbent articles are wearable. A wearable absorbent article is configured to be worn on or around a body of a wearer. Wearable absorbent articles can also be disposable. Examples of disposable wearable absorbent articles include disposable diapers and disposable incontinence undergarments. A disposable wearable absorbent article can receive and contain bodily exudates while being worn by a wearer. In some embodiments, a disposable wearable absorbent article can include a topsheet, an absorbent core, an outer cover, a waist opening, and leg openings. Disposable wearable absorbent articles can use embodiments of the present disclosure.

[0024] One kind of wetness indicator for an absorbent article is a visual fullness indicator. A wetness indicator is considered visual if it can indicate the presence of a liquid bodily exudate by its visual state. Throughout the present disclosure, unless otherwise stated, the presence of a liquid bodily exudate refers to the presence of a concentration of the liquid bodily exudate that is sufficient to cause a visual wetness indicator to change visual states. A wetness indicator is considered a fullness indicator if it can indicate the degree to which a liquid bodily exudate has filled an absorbent article. A visual fullness indicator can indicate the presence of a liquid bodily exudate by a wet edge that moves along the indicator such that the indicator progressively changes visual states. An indicator can include one or more indicating areas. An indicating area is a defined continuous two-dimensional region, configured to indicate the presence of a liquid bodily exudate by its visual state. As examples, in various embodiments, an indicator can comprise a series of indicating areas or a pattern of indicating areas.

[0025] The figures of the present disclosure are intended to illustrate elements, their parts, and their relationships, as described in the specification; the figures are not intended to illustrate any particular relative or absolute size or dimension, unless otherwise stated in the text.

[0026] FIGS. 1A-2C illustrate various disposable wearable absorbent articles, each with one or more indicators. For clarity, FIGS. 1A-2C do not illustrate all details of the indicators or of the disposable wearable absorbent articles. Each indicator in FIGS. 1A-2C can be any embodiment of an indicator of the present disclosure.

[0027] FIG. 1A illustrates an outside perspective view of a front 101 and a side 103 of a pant-type disposable wearable absorbent article 100A formed for wearing. The pant-type disposable wearable absorbent article 100A includes a waist opening 107 and a leg opening 108. The absorbent article 100A includes a longitudinally oriented visual fullness indicator 131 disposed in the front 101.

[0028] Throughout the present disclosure, a reference to a pant-type disposable wearable absorbent article can refer to an embodiment that is side-fastenable or to an embodiment without fasteners. A reference to a pant-type disposable wearable absorbent article can also refer to an article with preformed waist and/or leg openings or to an embodiment that is not preformed. Thus, each embodiment of an absorbent article of the present disclosure that is described as pant-type can be configured in any of these ways, as will be understood by one of ordinary skill in the art.

[0029] FIG. 1B illustrates an outside perspective view of a side 103 and a back 105 of a pant-type disposable wearable absorbent article 100B formed for wearing. The pant-type disposable wearable absorbent article 100B includes a waist opening 107 and a leg opening 108. The absorbent article 100B includes a longitudinally oriented visual fullness indicator 135 in the back 105.

[0030] FIG. 1C illustrates an outside plan view of a pant-type disposable wearable absorbent article 100C laid out flat. The disposable wearable absorbent article 100C includes a front 101 and a back 105, which are separated by a lateral centerline 116.

[0031] In FIG. 1C, a longitudinal centerline 113 and the lateral centerline 116 provide lines of reference for referring to relative locations of the disposable wearable absorbent article 100C. When a first location is nearer to the longitudinal centerline 113 than a second location, the first location can be considered laterally inboard 112 to the second location. Similarly, the second location can be considered laterally outboard 111 from the first location. When a third location is nearer to the lateral centerline 116 than a fourth location, the third location can be considered longitudinally inboard 115 to the fourth location. Also, the fourth location can be considered longitudinally outboard 114 from the third location.

[0032] A reference to an inboard location, without a lateral or longitudinal limitation, refers to a location of the disposable wearable absorbent article 100C that is laterally inboard and/or longitudinally inboard to another location. In the same way, a reference to an outboard location, without a lateral or longitudinal limitation, refers to a location of the disposable wearable absorbent article 100C that is laterally outboard and/or longitudinally outboard from another location.

[0033] Inboard and outboard can also be understood with reference to a center of a disposable wearable absorbent article. The longitudinal centerline 113 and the lateral centerline 116 cross at a center 119 of the disposable wearable absorbent article 100C. When one location is nearer to the center 119 than another location, the one location can be considered inboard to the other location. The one location can be inboard laterally, or longitudinally, or both laterally and longitudinally. The other location can be considered outboard from the one location. The other location can be outboard laterally, or longitudinally, or both laterally and longitudinally.

[0034] FIG. 1C includes arrows indicating relative directions for laterally outboard 111, laterally inboard 112, longitudinally outboard 114, and longitudinally inboard 115, each with respect to the disposable wearable absorbent article 100C. Throughout the present disclosure, a reference to a longitudinal dimension, measurement, line, or direction refers to a dimension, measurement, line, or direction that is substantially or completely parallel to the longitudinal centerline 113 and a reference to a lateral dimension, measurement, line, or direction refers to a dimension, measurement, line, or direction that is substantially or completely parallel to the lateral centerline 116. The terminology for describing relative locations, as discussed above, is used for disposable wearable absorbent articles throughout the present disclosure. This terminology can also be similarly applied to various other absorbent articles, as will be understood by one of ordinary skill in the art.

[0035] The disposable wearable absorbent article 100C includes a topsheet 106, an outer cover 109, an acquisition layer 191, a distribution layer 193, and an absorbent core 195.

A portion of the outer cover **109** is shown as broken to illustrate a portion of the topsheet **106** and a portion of the absorbent core **195**. A portion of the absorbent core **195** is shown as broken to illustrate a portion of the distribution layer **193**. A portion of the distribution layer **193** is shown as broken to illustrate a portion of the acquisition layer **191**.

[0036] The disposable wearable absorbent article **100C** includes a number of visual fullness indicators in various exemplary locations and orientations. The disposable wearable absorbent article **100C** includes a longitudinally oriented visual fullness indicator **131**, along the longitudinal centerline **113** in the front **101**. The front **101** also includes a first angled visual fullness indicator **132**, oriented at an angle between the longitudinal centerline **113** and the lateral centerline **116**.

[0037] The disposable wearable absorbent article **100C** includes a first laterally oriented visual fullness indicator **133** and a second laterally oriented visual fullness indicator **137**, each along the lateral centerline **116**. The disposable wearable absorbent article **100C** further includes a longitudinally oriented visual fullness indicator **135**, along the longitudinal centerline **113** in the back **105**. The back **105** also includes a third angled visual fullness indicator **134** and a fourth angled visual fullness indicator **136**, each oriented at an angle between the longitudinal centerline **113** and the lateral centerline **116**.

[0038] In the disposable wearable absorbent article **100C**, the visual fullness indicators are oriented substantially radially out from the center **119**. However, in addition to the locations and orientations illustrated in FIG. 1C, a visual fullness indicator of the present disclosure can be disposed in various alternate locations and orientations in an absorbent article, as will be understood by one of ordinary skill in the art. As an example, a visual fullness indicator can be disposed in a pant-type disposable wearable absorbent article at a location relative to a pee point for a wearer of the article.

[0039] FIG. 2A illustrates an outside perspective view of a front **201** and a side **203** of a front-fastenable disposable wearable absorbent article **200A** formed for wearing. The front-fastenable disposable wearable absorbent article **200A** includes a waist opening **207** and a leg opening **208**. The absorbent article **200A** includes a longitudinally oriented visual fullness indicator **231** disposed in the front **201**.

[0040] While the present disclosure refers to front-fastenable absorbent articles, the present disclosure also contemplates alternate embodiments of absorbent articles having multiple indicating colors, as described herein, wherein the absorbent articles are rear-fastenable. Thus, each embodiment of an absorbent article of the present disclosure that is described as front-fastenable can also be configured to be rear fastenable, as will be understood by one of ordinary skill in the art.

[0041] FIG. 2B illustrates an outside perspective view of a side **203** and a back **205** of a front-fastenable disposable wearable absorbent article **200B** formed for wearing. The front-fastenable disposable wearable absorbent article **200B** includes a waist opening **207** and a leg opening **208**. The absorbent article **200B** includes a longitudinally oriented visual fullness indicator **235** in the back **205**.

[0042] FIG. 2C illustrates an outside plan view of a front-fastenable disposable wearable absorbent article **200C** laid out flat. The disposable wearable absorbent article **200C** includes a front **201**, a back **205**, a longitudinal centerline **213**, and a lateral centerline **216**.

[0043] In FIG. 2C, the longitudinal centerline **213** and the lateral centerline **216** provide lines of reference for referring to relative locations of the disposable wearable absorbent article **200C**. When a first location is nearer to the longitudinal centerline **213** than a second location, the first location can be considered laterally inboard **212** to the second location. Similarly, the second location can be considered laterally outboard **211** from the first location. When a third location is nearer to the lateral centerline **216** than a fourth location, the third location can be considered longitudinally inboard **215** to the fourth location. Also, the fourth location can be considered longitudinally outboard **214** from the third location.

[0044] The disposable wearable absorbent article **200C** includes a topsheet **206**, an outer cover **209**, an acquisition layer **291**, a distribution layer **293**, and an absorbent core **295**. A portion of the outer cover **209** is shown as broken to illustrate a portion of the topsheet **206** and a portion of the absorbent core **295**. A portion of the absorbent core **295** is shown as broken to illustrate a portion of the distribution layer **293**. A portion of the distribution layer **293** is shown as broken to illustrate a portion of the acquisition layer **291**.

[0045] The disposable wearable absorbent article **200C** includes a number of visual fullness indicators in various exemplary locations and orientations. The disposable wearable absorbent article **200C** includes a longitudinally oriented visual fullness indicator **231**, along the longitudinal centerline **213** in the front **201**. The front **201** also includes a first angled visual fullness indicator **232**, oriented at an angle between the longitudinal centerline **213** and the lateral centerline **216**.

[0046] The disposable wearable absorbent article **200C** includes a first laterally oriented visual fullness indicator **233** and a second laterally oriented visual fullness indicator **237**, each along the lateral centerline **216**. The disposable wearable absorbent article **200C** further includes a longitudinally oriented visual fullness indicator **235**, along the longitudinal centerline **213** in the back **205**. The back **205** also includes a third angled visual fullness indicator **234** and a fourth angled visual fullness indicator **236**, each oriented at an angle between the longitudinal centerline **213** and the lateral centerline **216**.

[0047] In the disposable wearable absorbent article **200C**, the visual fullness indicators are oriented substantially radially out from the center **219**. However, in addition to the locations and orientations illustrated in FIG. 2C, a visual fullness indicator of the present disclosure can be disposed in various alternate locations and orientations in an absorbent article, as will be understood by one of ordinary skill in the art. As an example, a visual fullness indicator can be disposed in a front-fastenable disposable wearable absorbent article at a location relative to a pee point for a wearer of the article.

[0048] FIG. 3A illustrates an outside plan view of a portion **308** of an absorbent article **300** laid out flat. In various embodiments, the absorbent article **300** can be a disposable wearable absorbent article, such as a pant-type disposable wearable absorbent article or a front-fastenable disposable wearable absorbent article. In FIG. 3A, outside edges of the portion **308** are broken lines, since the portion **308** is illustrated as separate from the rest of the absorbent article **300**. For reference, FIG. 3A illustrates a center **319** of the absorbent article **300** and arrows indicating relative directions for outboard **317** and inboard **318** for the absorbent article **300**.

[0049] The portion **308** of the absorbent article **300** includes a visual fullness indicator **320**. The visual fullness

indicator **320** is disposed offset from the center **319**. In various embodiments, one or more parts of a visual fullness indicator can be disposed near, at, or overlapping a center of an absorbent article. For example, a single indicating area can extend from a front of an absorbent article, through the center of the absorbent article, to the back of the absorbent article. In such an embodiment, a farthest inboard point along the indicating area can be considered an inboard end of two indicators.

[0050] The visual fullness indicator **320** includes an inboard end **322** and an outboard end **323**. The visual fullness indicator **320** has an overall indicator length **321**, measured along the visual fullness indicator **320** from the inboard end **322** to the outboard end **323**. The visual fullness indicator **320** has an overall shape that is substantially elongated and substantially rectangular. The visual fullness indicator **320** has a substantially uniform width along the entire overall indicator length **321**.

[0051] In various embodiments a visual fullness indicator can have an overall shape that is more or less elongated. In some embodiments, part, or parts, or all of a visual fullness indicator can be straight, curved, angled, segmented, or any regular or irregular geometric shape (such as a square, rectangle, triangle, trapezoid, octagon, hexagon, star, half circle, a quarter circle, a half oval, a quarter oval, a radial pattern, etc.), a recognizable image (such as a letter, number, word, character, face of an animal, face of a person, etc.), or another recognizable image (such as a plant, a car, etc.), another shape, or combinations of any of these shapes. Also, in various embodiments, an indicator can have varying widths over part, or parts, or all of its length.

[0052] A visual fullness indicator is a visually distinct and recognizable pathway of one or more visual indicators and/or visual indicating areas. A pathway is recognizable in its visual context. In other words, a pathway is distinct and recognizable, when compared with the appearance of a surrounding area.

[0053] The pathway of a visual fullness indicator has two defined ends, a middle between the two ends, and a defined length from its one end to its other end. A visual fullness indicator can have one or more widths, each of which is less than its defined length.

[0054] A visual fullness indicator can be configured in various forms. For example, a visual fullness indicator can be formed by a single, continuous indicating area disposed along a pathway. As another example, a visual fullness indicator can be formed by a plurality of discrete indicators and/or discrete indicating areas disposed along a pathway.

[0055] The visual fullness indicator **320** includes, at least, a first visual fullness indicating area **340** and a second visual fullness indicating area **360**. In various embodiments, a visual fullness indicator can include three or more visual fullness indicating areas.

[0056] The first visual fullness indicating area **340** includes a first area inboard end **342**, a first area outboard end **343**, and a first area overall length **341** measured along the first visual fullness indicating area **340** from the first area inboard end **342** to the first area outboard end **343**. The first visual fullness indicating area **340** has an overall shape that is substantially elongated and substantially rectangular. The first visual fullness indicating area **340** has a substantially uniform width along the entire first area overall length **341**. However, in some embodiments, a visual fullness indicating area can have

various shapes and various widths over part, or parts, or all of its length, as described above in connection with the visual fullness indicator.

[0057] In addition to the first visual fullness indicating area **340**, the visual fullness indicator **320** includes a second visual fullness indicating area **360**. In the embodiment of FIG. 3A, the second visual fullness indicating area **360** is outboard **317** from the first visual fullness indicating area **340**. The second visual fullness indicating area **360** includes a second area inboard end **362**, a second area outboard end **363**, and a second area overall length **361** measured along the second visual fullness indicating area **360** from the second area inboard end **362** to the second area outboard end **363**. In the embodiment of FIG. 3A, the second area overall length **361** is less than the first area overall length **341**. In some embodiments, a second area overall length can be equal to a first area overall length or greater than a first area overall length.

[0058] The second visual fullness indicating area **360** has an overall shape that is substantially elongated and substantially rectangular. The second visual fullness indicating area **360** has a substantially uniform width along the entire second area overall length **361**.

[0059] The visual fullness indicator **320** is in fluid communication with an absorbent core of the absorbent article **300** along the entire overall indicator length **321**. In various embodiments, a visual indicator can be configured such that part, or parts, or substantially all, or all of the indicator is in fluid communication with an absorbent core. In some embodiments, a visual indicator can be configured such that part, or parts, or substantially all, or all of the indicator overlaps an absorbent core or such that part, or parts, or substantially all, or all of the indicator does not overlap an absorbent core.

[0060] Throughout the present disclosure, fluid communication refers to a configured structural relationship that allows a liquid substance to freely pass from one element or location to another element or location; however, one element or location is not necessarily considered to be in fluid communication with another element or location merely by being connected or joined to a common element through which liquid can possibly pass. This definition of fluid communication is further explained by the following examples.

[0061] For example, if one element is configured to be in direct physical contact with another element such that a liquid substance can freely pass from the one element through the contacting portions to the other element, then the elements can be considered to be in fluid communication. As another example, if one element is connected to another element by a means for fluid communication such that a liquid substance can freely pass from the one element through the means for fluid communication to the other element, then the elements can be considered to be in fluid communication.

[0062] As a further example, if one element is connected to a substrate and another element is connected to the same substrate, but the substrate does not allow a liquid substance to freely pass through, then the elements are considered to be out of fluid communication. This holds true even if liquid can possibly pass through the substrate, so long as the liquid cannot pass through freely. The above definition of fluid communication, as explained through these examples, will be understood by one of ordinary skill in the art.

[0063] Throughout the present disclosure, the term liquid bodily exudate refers to any bodily substances exuded in liquid form (e.g. urine) and/or any liquid-like bodily substances (e.g. runny feces).

[0064] In the embodiment of FIG. 3A, the first visual fullness indicating area 340 and the second visual fullness indicating area 360 are immediately adjacent to each other and in contact with each other at a shared boundary 351. The first visual fullness indicating area 340 is configured to be in direct physical contact with the second visual fullness indicating area 360 at the shared boundary 351.

[0065] In various embodiments, part, or parts, or all of an indicating area can be configured to change from an initial color to a subsequent color. The initial color and the subsequent color can each be any variation of any color, so long as the subsequent color is visually distinguishable from the initial color.

[0066] Throughout the present disclosure, the term color refers to a color and/or variations of a color. Colors include well-known colors such as red, orange, yellow, green, blue, purple, etc. Variations of a color include variations in chroma, hue, and brightness, among others. While these informal terms are used for ease of reference, embodiments of the present disclosure are intended to encompass all colors that can be perceived by an unaided human with normal vision in standard lighting conditions.

[0067] Throughout the present disclosure, the term visually distinguishable colors refers to colors or variations of color(s) which can be recognized as different on sight by an unaided human with normal vision in standard lighting conditions. As an example, an unaided human with normal vision should, in standard lighting conditions, be able to recognize blue and yellow as different colors on sight. Thus, the blue and the yellow would be considered visually distinguishable colors. As a further example, an unaided human with normal vision may, in standard lighting conditions, also be able to recognize a light shade of orange and a dark shade of orange as different shades of a color on sight. Thus, the light shade of orange and the dark shade of orange would also be considered visually distinguishable colors.

[0068] There are several ways by which absorbent articles of the present disclosure can be configured to include indicating areas that change colors when indicating the presence of a bodily exudate, as will be understood by one of ordinary skill in the art. For example, an absorbent article can be configured to include indicators as described in the following U.S. patents: U.S. Pat. No. 4,022,211, entitled "Wetness indicator for absorbent pads" issued on May 10, 1977 to Timmons, et al.; U.S. Pat. No. 4,231,370, entitled "Disposable diaper type garment having wetness indicator" issued on Nov. 4, 1980 to Mroz, et al.; U.S. Pat. No. 4,327,731, entitled "Moisture indicator" issued on May 4, 1982 to Powell; U.S. Pat. No. 4,681,576, entitled "Wetness indicating hot-melt adhesive" issued on Jul. 21, 1987 to Colon, et al.; U.S. Pat. No. 4,705,513, entitled "Disposable diaper with wetness indicator" issued on Nov. 10, 1987 to Sheldon, et al.; U.S. Pat. No. 4,738,674, entitled "Moisture indicator apparatus and method" issued on Apr. 19, 1988 to Todd, et al.; U.S. Pat. No. 4,743,238, entitled "Wetness indicating hot-melt adhesive" issued on May 10, 1988 to Colon et al.; U.S. Pat. No. 4,895,567, entitled "Wetness indicating hot-melt adhesive" issued on Jan. 23, 1990 to Colon et al.; U.S. Pat. No. 4,931,051, entitled "Wetness indicator" issued on Jun. 5, 1990 to Castello; U.S. Pat. No. 5,035,691, entitled "Hot melt moisture

indicator material for disposable articles" issued on Jul. 30, 1991 to Zimmer, et al.; U.S. Pat. No. 5,066,711, entitled "Wetness indicating hot-melt adhesive" issued on Nov. 19, 1991 to Colon et al.; U.S. Pat. No. 5,089,548, entitled "Hot melt moisture indicator material for disposable articles" issued on Feb. 18, 1992 to Zimmer, et al.; U.S. Pat. No. 5,167,652, entitled "Moisture sensitive film" issued on Dec. 1, 1992 to Mueller; U.S. Pat. No. 5,342,861, entitled "Hot melt wetness indicator" issued on Aug. 30, 1994 to Raykovitz; U.S. Pat. No. 5,354,289 entitled "Absorbent product including super absorbent material and fluid absorption capacity monitor" issued on Oct. 11, 1994 to Mitchell, et al.; H1,376, entitled "Capacity indicia for absorbent articles" issued on Nov. 1, 1994 to Osborne, et al.; U.S. Pat. No. 5,647,863, entitled "Absorbent article with clean appearance and capacity signal means" issued on Jul. 15, 1997 to Hammons, et al.; U.S. Pat. No. 5,690,624, entitled "Disposable diaper" issued on Nov. 25, 1997 to Sasaki, et al.; U.S. Pat. No. 5,766,212, entitled "Disposable diaper" issued on Jun. 16, 1998 to Jitoe, et al.; U.S. Pat. No. 6,075,178, entitled "Absorbent article with wetness indicator" issued on June 13, 2000; U.S. Pat. No. 6,515,194, entitled "Diaper having centrally-located chromatographic layer with peripherally-located wetness indicator" issued on Feb. 4, 2003 to Neading, et al.; U.S. Pat. No. 6,596,918, entitled "Absorbent articles having wetness indicating graphics and employing masking techniques" issued on Jul. 22, 2003 to Wehrle, et al.; U.S. Pat. No. 6,653,522, entitled "Hot melt adhesives based on sulfonated polyesters comprising wetness indicator" issued on Nov. 25, 2003 to Blumenthal, et al.; U.S. Pat. No. 6,772,708, entitled "Wetness indicator having improved colorant retention" issued on Aug. 10, 1994 to Klofta, et al.; U.S. Pat. No. 6,904,865, entitled "Wetness indicator having improved colorant retention and durability" issued on Jun. 14, 2005 to Klofta, et al.; U.S. Pat. No. 7,159,532, entitled "Wetness indicator having improved colorant retention and durability" issued on Jan. 9, 2007 to Klofta, et al.; U.S. Pat. No. 7,172,667, entitled "System and method for incorporating graphics into absorbent articles" issued on Feb. 6, 2007 to Vergona; U.S. Pat. No. 7,178,571, entitled "System and method for incorporating graphics into absorbent articles" issued on Feb. 20, 2007 to Vergona; U.S. Pat. No. 7,306,764, entitled "Wetness indicator" issued on Dec. 11, 2007 to Mody; and U.S. Pat. No. 7,332,642, entitled "Disposable absorbent articles having printed wetness indicators" issued on Feb. 19, 2008 to Liu, each of which is incorporated herein by reference.

[0069] In the embodiment of FIG. 3A, the first visual fullness indicating area 340 is configured to change from a first initial color to a first subsequent color when indicating the presence of a liquid bodily exudate. The second visual fullness indicating area 360 is configured to have a second initial color that can be similar to, the same as, or different from the first initial color. The second visual fullness indicating area 360 is configured to change from the second initial color to a second subsequent color when indicating the presence of a liquid bodily exudate. The second subsequent color of the second visual fullness indicating area 360 is visually distinguishable from the first subsequent color of the first visual fullness indicating area 340. As examples, a first subsequent color can be the color green, blue, purple, or variations thereof while a second subsequent color can be the color yellow, orange, red, or variations thereof.

[0070] An absorbent article can be configured such that part, or parts, or all of a visual indicating area is visible from

outside of the absorbent article when the absorbent article is worn by a wearer. For example, a visual fullness indicating area can be visible when viewing an outside of an outer cover of an absorbent article. As a result, at least some of a subsequent color of the visual indicating area will be visible from outside of the absorbent article.

[0071] The absorbent article 300 can be configured such that part, or parts, or all of each of the first visual fullness indicating area 340 and the second visual fullness indicating area 360 is visible from outside of the absorbent article 300 when the absorbent article 300 is worn by a wearer. As a result, at least some of the first subsequent color and at least some of the second subsequent color will be visible from outside of the absorbent article 300.

[0072] The visual fullness indicator 320 can be configured such that the first visual fullness indicating area 340 and the second visual fullness indicating area 360 change colors progressively and in sequence, as illustrated with FIGS. 3B-3E. First, the first visual fullness indicating area 340 can change from a first initial color to a first subsequent color when indicating the presence of a liquid bodily exudate to a first extent in an absorbent core of the absorbent article 300. Second, the second visual fullness indicating area 360 can change from a second initial color to a second subsequent color when indicating the presence of a liquid bodily exudate to a second extent in an absorbent core of the absorbent article 300. The partial or complete absence or presence of the first subsequent color and/or the second subsequent color on the visual fullness indicator 320 can indicate the fullness of the absorbent article 300.

[0073] Since the second subsequent color of the second visual fullness indicating area 360 is visually distinguishable from the first subsequent color of the first visual fullness indicating area 340, the visual fullness indicator 320 is easy to understand. The two subsequent indicating colors of the visual fullness indicator 320 can help provide certainty about the fullness of the absorbent article 300. By knowing the fullness of the absorbent article 300, the absorbent article 300 can be changed after a wearer has appropriately utilized its capacity and/or before it is likely to leak. The benefits of visual fullness indicating areas with at least two subsequent indicating colors are similarly provided in the embodiments of FIGS. 4, 5, and 6, as described below.

[0074] FIGS. 3B-3E illustrate the visual fullness indicating areas of the visual fullness indicator 320 of the embodiment of FIG. 3A in various states of indication. The first visual fullness indicating area 340 and the second visual fullness indicating area 360 change colors progressively and in sequence in the presence of a liquid bodily exudate to indicate the fullness of the absorbent article 300. In FIGS. 3B-3E, visually distinguishable subsequent indicating colors are illustrated with different hatch patterns.

[0075] FIG. 3B illustrates a subsequent state of indication for the visual fullness indicator 320 of FIG. 3A, wherein part of the first visual fullness indicating area 340 has changed from a first initial color 348 to a first subsequent color 349 while all of the second visual fullness indicating area 360 remains a second initial color 368, to indicate the fullness of the absorbent article 300. In FIG. 3B, a liquid bodily exudate has passed through a portion of the absorbent core of the absorbent article 300 in sufficient concentration to cause a change in visual state from the inboard end 322 of the visual fullness indicator 320 up through part of the first visual fullness indicating area 340 to a wet edge 357B.

[0076] Throughout the present disclosure, a wet edge refers to a boundary along a visual wetness indicator of an absorbent article, wherein the boundary indicates an extent of the presence of a liquid bodily exudate. On the inboard side of the wet edge, the visual wetness indicator has experienced the presence of a liquid bodily exudate at a concentration that is sufficient to cause the visual wetness indicator to change visual states. On the outboard side of the wet edge, the visual wetness indicator has not yet experienced the presence of a liquid bodily exudate at a concentration that is sufficient to cause the visual wetness indicator to change visual states.

[0077] FIG. 3C illustrates a subsequent state of indication for the visual fullness indicator 320 of FIG. 3B, wherein all of the first visual fullness indicating area 340 has changed to the first subsequent color 349 while all of the second visual fullness indicating area 360 remains the second initial color 368, to indicate the fullness of the absorbent article 300. In FIG. 3C, a liquid bodily exudate has passed through a portion of the absorbent core of the absorbent article 300 in sufficient concentration to cause a change in visual state from the inboard end 322 of the visual fullness indicator 320 up through all of the first visual fullness indicating area 340 to a wet edge 357C.

[0078] FIG. 3D illustrates a subsequent state of indication for the visual fullness indicator 320 of FIG. 3C, wherein all of the first visual fullness indicating area 340 has changed to the first subsequent color 349 and part of the second visual fullness indicating area 360 has changed from the second initial color 368 to a second subsequent color 369 that is visually distinguishable from the first subsequent color 349 to indicate the fullness of the absorbent article 300. In FIG. 3D, a liquid bodily exudate has passed through a portion of the absorbent core of the absorbent article 300 in sufficient concentration to cause a change in visual state from the inboard end 322 of the visual fullness indicator 320 up through all of the first visual fullness indicating area 340 and up through part of the second visual fullness indicating area 360 to a wet edge 357D.

[0079] FIG. 3E illustrates a subsequent state of indication for the visual fullness indicator 320 of FIG. 3D, wherein all of the first visual fullness indicating area 340 has changed to the first subsequent color 349 and all of the second visual fullness indicating area 360 has changed to the second subsequent color 369 to indicate the fullness of the absorbent article 300. In FIG. 3E, a liquid bodily exudate has passed through a portion of the absorbent core of the absorbent article 300 in sufficient concentration to cause a change in visual state from the inboard end 322 of the visual fullness indicator 320 up through all of the first visual fullness indicating area 340 and up through all of the second visual fullness indicating area 360 to a wet edge 357E, which is near the outboard end 323 of the visual fullness indicator 320.

[0080] Together, FIGS. 3B-3E illustrate that the visual fullness indicating areas of the visual fullness indicator 320 can change colors progressively and in sequence in the presence of a liquid bodily exudate to indicate the degree to which a liquid bodily exudate has filled the absorbent article 300. In addition to indicating fullness, in embodiments of the present disclosure, such color changes can also be understood as a signal that indicates the remaining absorbent capacity of an absorbent article and/or as a signal that indicates the risk that an absorbent article may leak.

[0081] An appropriate particular location and orientation, as well as specific dimensions and other physical characteristics, can be selected for visual fullness indicators of the

present disclosure in order for an indicator to provide color change signals that indicate the degree of fullness, the remaining capacity, and/or the leakage risk for a particular absorbent article. In various embodiments, the absorbent article can also include indicia correlating the color change signals with fullness, capacity, and/or leakage risk. Further, in some embodiments, instructions for the absorbent article can explain the correlation between the color change signals and fullness, capacity, and/or leakage risk. For example, such instructions can be provided on packaging for the absorbent article or on printed material accompanying the absorbent article. Still further, the correlation between the color change signals and fullness, capacity, and/or leakage risk can be communicated through various advertising media.

[0082] For each visual fullness indicating area of the present disclosure, the location of the inboard end and the outboard end can be selected to provide visual signals that indicate the degree of fullness, the remaining capacity, and/or the leakage risk for the absorbent article in which the indicating area is included. The degree of fullness, the remaining capacity, and/or the leakage risk for a particular absorbent article can be determined as described in U.S. non-provisional patent application entitled "Absorbent Articles with Primary and Secondary Indicating," filed on Dec. 23, 2009 under attorney docket number 11222MQ, application Ser. No. 12/646,414, which is incorporated herein by reference.

[0083] As a first example, in various embodiments, an inboard end of a first visual fullness indicating area can be disposed at a particular location, such that, a change in visual state at that inboard end (i.e. a wet edge proximate to that inboard end) indicates that the absorbent article has: (a) a fullness of about 25%, 30%, 35%, 40%, 45%, 50%, 55%, 60%, 65%, 70%, 75%, 80%, 85%, or any integer of percentage between any of these values, or within any range using any of these values; (b) a remaining capacity of about 75%, 70%, 65%, 60%, 55%, 50%, 45%, 40%, 35%, 30%, 25%, 20%, 15%, or any integer of percentage between any of these values, or within any range using any of these values; and/or (c) a leakage risk of >0%, 5%, 10%, 15%, 20%, 25%, 30%, 35%, 40%, 45%, 50%, 55%, 60%, 65%, 70%, 75%, 80%, 85%, or any integer of percentage between any of these values, or within any range using any of these values. As used herein, the term "leakage risk" refers to the probability of a liquid bodily exudate leaking out of an absorbent article, while the article is being properly worn by a wearer of appropriate size, with such probability being measured in a sufficient number of articles being used by a sufficient number of wearers of appropriate size. For example, at least 100 users should use at least five days worth of articles to determine the probability of an article leaking

[0084] An inboard end of a first visual fullness indicating area can be disposed in an absorbent article at any of the following locations: 80 mm, 70 mm, 60 mm, 50 mm, 40 mm, 30 mm, 20 mm, 10 mm, or 5 mm inboard to an outer edge of an acquisition layer; at an outer edge of an acquisition layer; 80 mm, 70 mm, 60 mm, 50 mm, 40 mm, 35mm, 30 mm, 25 mm, 20 mm, 15 mm, 10 mm, or 5 mm inboard to an outer edge of a distribution layer; at an outer edge of a distribution layer; 140 mm, 130 mm, 120 mm, 110 mm, 100 mm, 90 mm, 80 mm, 70 mm, 60 mm, 50 mm, 40 mm, 30 mm, 20 mm, 10 mm, or 5 mm inboard to an outer edge of an absorbent core; or at an outer edge of an absorbent core. An inboard end of a first visual fullness indicating area can also be disposed in an

absorbent article at any integer of mm between any of these values or within any range using any of these values.

[0085] As a second example, in various embodiments, an outboard end of a first visual fullness indicating area can be disposed at a particular location, such that, a change in visual state at that outboard end (i.e. a wet edge proximate to that outboard end) indicates that the absorbent article has: (a) a fullness of 30%, 35%, 40%, 45%, 50%, 55%, 60%, 65%, 70%, 75%, 80%, 85%, 90%, or any integer of percentage between any of these values, or within any range using any of these values; (b) a remaining capacity of 70%, 65%, 60%, 55%, 50%, 45%, 40%, 35%, 30%, 25%, 20%, 15%, 10%, or any integer of percentage between any of these values, or within any range using any of these values; and/or (c) a leakage risk of 30%, 35%, 40%, 45%, 50%, 55%, 60%, 65%, 70%, 75%, 80%, 85%, 90%, or any integer of percentage between any of these values, or within any range using any of these values.

[0086] An outboard end of a first visual fullness indicating area can be disposed in an absorbent article at any of the following locations: 70 mm, 60 mm, 50 mm, 40 mm, 30 mm, 20 mm, 10 mm, or 5 mm inboard to an outer edge of an acquisition layer; at an outer edge of an acquisition layer; 5 mm or 10 mm outboard from an outer edge of an acquisition layer; 70 mm, 60 mm, 50 mm, 40 mm, 30 mm, 25 mm, 20 mm, 15 mm, 10 mm, or 5 mm inboard to an outer edge of a distribution layer; at an outer edge of a distribution layer; 5 mm or 10 mm outboard from an outer edge of a distribution layer; 130 mm, 120 mm, 110 mm, 100 mm, 90 mm, 80 mm, 70 mm, 60 mm, 50 mm, 40 mm, 30 mm, 20 mm, 10 mm, or 5 mm inboard to an outer edge of an absorbent core; at an outer edge of an absorbent core; or 5 mm or 10 mm outboard from an outer edge of an absorbent core. An outboard end of a first visual fullness indicating area can also be disposed in an absorbent article at any integer of mm between any of these values, or within any range using any of these values.

[0087] As a third example, in various embodiments, an inboard end of a second visual fullness indicating area can be disposed at a particular location, such that, a change in visual state at that inboard end (i.e. a wet edge proximate to that inboard end) indicates that the absorbent article has: (a) a fullness of 50%, 55%, 60%, 65%, 70%, 75%, 80%, 85%, 90%, 95% or any integer of percentage between any of these values, or within any range using any of these values; (b) a remaining capacity of 50%, 45%, 40%, 35%, 30%, 25%, 20%, 15%, 10%, 5%, or any integer of percentage between any of these values, or within any range using any of these values; and/or (c) a leakage risk of 10%, 20%, 30%, 40%, 50%, 60%, 70%, 80%, 90%, or any integer of percentage between any of these values, or within any range using any of these values

[0088] A change in visual state at an inboard end of a second visual fullness indicating area may indicate a fullness that is less than, or equal to, or greater than a fullness indicated by a change in visual state at an outboard end of a first visual fullness indicating area. A change in visual state at an inboard end of a second visual fullness indicating area may indicate a remaining capacity that is greater than, or equal to, or less than a remaining capacity indicated by a change in visual state at an outboard end of a first visual fullness indicating area. A change in visual state at an inboard end of a second visual fullness indicating area may indicate a leakage risk that is greater than, or equal to, or less than a leakage risk indicated by a change in visual state at an outboard end of a

first visual fullness indicating area. A third visual fullness indicating area may be related to a second visual fullness indicating area in the same way that a second visual fullness indicating area relates to a first visual fullness indicating area, as described herein. Further, a subsequent visual fullness indicating areas may similarly be related to a prior visual fullness indicating area.

[0089] In various embodiments, a second visual fullness indicating area disposed in the back of an article can have an inboard end disposed with respect to a longitudinally outboard edge of an absorbent core disposed in the front of the article. In this way, the second visual fullness indicating area can be configured with respect to a point in the front/center of the article, where liquid bodily exudates are provided to the article by the wearer. As examples, a second visual fullness indicating area can be disposed in the back of an article with an inboard end of the indicating area disposed 275 mm, 270 mm, 260 mm, 250 mm, 240 mm, 230 mm, 220 mm, 210 mm, 200 mm, 190 mm, 180 mm, 170 mm, 160 mm, or 150 mm, from a longitudinally outboard edge of an absorbent core disposed in the front of the article. An inboard end of a second visual fullness indicating area can also be disposed in an absorbent article at any integer of mm between any of these values, or within any range using any of these values.

[0090] As a fourth example, in various embodiments, an outboard end of a second visual fullness indicating area can be disposed at a particular location, such that, a change in visual state at that outboard end (i.e. a wet edge proximate to that outboard end) indicates that the absorbent article has: (a) a fullness of 55%, 60%, 65%, 70%, 75%, 80%, 85%, 90%, 95%, about 100%, or any integer of percentage between any of these values, or within any range using any of these values; (b) a remaining capacity of 45%, 40%, 35%, 30%, 25%, 20%, 15%, 10%, 5%, about 0%, or any integer of percentage between any of these values, or within any range using any of these values; and/or (c) a leakage risk of 20%, 30%, 40%, 50%, 60%, 70%, 80%, 90%, about 100%, or any integer of percentage between any of these values, or within any range using any of these values.

[0091] An outboard end of a second visual fullness indicating area can be disposed in an absorbent article at any of the following locations: 50 mm, 40 mm, 30 mm, 20 mm, 10 mm, or 5 mm inboard to an outer edge of an acquisition layer; at an outer edge of an acquisition layer; 5 mm, 10 mm, 20 mm, or 30 mm outboard from an outer edge of an acquisition layer; 50 mm, 40 mm, 30 mm, 25 mm, 20 mm, 15 mm, 10 mm, or 5 mm inboard to an outer edge of a distribution layer; at an outer edge of a distribution layer; 5 mm, 10 mm, 20 mm, or 30 mm outboard from an outer edge of a distribution layer; 110 mm, 100 mm, 90 mm, 80 mm, 70 mm, 60 mm, 50 mm, 40 mm, 30 mm, 20 mm, or 10 mm inboard to an outer edge of an absorbent core; at an outer edge of an absorbent core; or 5 mm, 10 mm, 20 mm, or 30 mm outboard from an outer edge of an absorbent core. An outboard end of a second visual fullness indicating area can also be disposed in an absorbent article at any integer of mm between any of these values, or within any range using any of these values.

[0092] It is contemplated that any of the exemplary embodiments described above can be applied in any workable combination to any relevant embodiment of the present disclosure.

[0093] FIG. 4 illustrates an outside plan view of a portion 408 of an absorbent article 400 laid out flat. In various embodiments, the absorbent article 400 can be a disposable

wearable absorbent article, such as a pant-type disposable wearable absorbent article or a front-fastenable disposable wearable absorbent article. For reference, FIG. 4 illustrates a center 419 of the absorbent article 400 and arrows indicating relative directions for outboard 417 and inboard 418 for the absorbent article 400. The portion 408 includes a first visual fullness indicating area 440 and a second visual fullness indicating area 460. Each of the elements of the embodiment of FIG. 4 is configured in the same way as the like-numbered element of the embodiment of FIG. 3A, except as noted below.

[0094] Throughout the present disclosure, the term “like-numbered” is intended to indicate a correspondence between labels of elements wherein the last two numbers in the labels of the elements are the same. Element labels are considered to be like-numbered despite differing numeral prefixes corresponding to figure numbers, and despite differing alphabetical suffixes corresponding to particular embodiments.

[0095] In the embodiment of FIG. 4, the second visual fullness indicating area 460 is spaced apart from the first visual fullness indicating area 440 by a separating portion 455.

[0096] The first visual fullness indicating area 440 and the second visual fullness indicating area 460 can change colors progressively and in sequence, similar to the embodiment illustrated with FIGS. 3B-3E. The partial or complete absence or presence of the first subsequent color in the first visual fullness indicating area 440 and/or the partial or complete absence or presence of the second subsequent color in the second visual fullness indicating area 460 can indicate the fullness of the absorbent article 400.

[0097] Since the second subsequent color of the second visual fullness indicating area 460 is visually distinguishable from the first subsequent color of the first visual fullness indicating area 440, the fullness of the absorbent article 400 is easy to understand. The two subsequent indicating colors can help provide certainty about the fullness of the absorbent article 400. By knowing the fullness of the absorbent article 400, the absorbent article 400 can be changed after a wearer has appropriately utilized its capacity and/or before it is likely to leak.

[0098] FIG. 5 illustrates an outside plan view of a portion 508 of an absorbent article 500 laid out flat. In various embodiments, the absorbent article 500 can be a disposable wearable absorbent article, such as a pant-type disposable wearable absorbent article or a front-fastenable disposable wearable absorbent article. For reference, FIG. 5 illustrates a center 519 of the absorbent article 500 and arrows indicating relative directions for outboard 517 and inboard 518 for the absorbent article 500. The portion 508 includes a visual fullness indicator 520, which includes, at least, a first visual fullness indicating area 540 and a second visual fullness indicating area 560. Each of the elements of the embodiment of FIG. 5 is configured in the same way as the like-numbered element of the embodiment of FIG. 3A, except as noted below.

[0099] In addition to the first visual fullness indicating area 540 and the second visual fullness indicating area 560, the visual fullness indicator 520 includes a third visual fullness indicating area 580. In various embodiments, a visual fullness indicator can include four or more visual fullness indicating areas.

[0100] The third visual fullness indicating area 580 is outboard 517 from the second visual fullness indicating area 560.

The third visual fullness indicating area **580** has an overall shape that is substantially elongated and substantially rectangular. The third visual fullness indicating area **580** has a substantially uniform width along its entire length.

[0101] In the embodiment of FIG. 5, the third visual fullness indicating area **580** is configured to change from a third initial color to a third subsequent color when indicating the presence of a liquid bodily exudate. The third subsequent color of the third visual fullness indicating area **580** is visually distinguishable from the second subsequent color of the second visual fullness indicating area **560**. As examples, a third subsequent color can be the color yellow, orange, red, or variations thereof.

[0102] The absorbent article **500** can be configured such that part, or parts, or all of the third visual fullness indicating area **580** is visible from outside of the absorbent article **500** when the absorbent article **500** is worn by a wearer. As a result, at least some of the third subsequent color will be visible from outside of the absorbent article **500**.

[0103] The first visual fullness indicating area **540**, the second visual fullness indicating area **560**, and the third visual fullness indicating area **580** can change colors progressively and in sequence, similar to the embodiment illustrated with FIGS. 3B-3E, but with the addition of a color change in the third visual fullness indicating area **580**. The partial or complete absence or presence of the first subsequent color and/or the second subsequent color and/or the third subsequent color on the visual fullness indicator **520** can indicate the fullness of the absorbent article **500**.

[0104] Since the third subsequent color of the third visual fullness indicating area **580** is visually distinguishable from the second subsequent color of the second visual fullness indicating area **560** and the second subsequent color of the second visual fullness indicating area **560** is visually distinguishable from the first subsequent color of the first visual fullness indicating area **540**, the fullness of the absorbent article **500** is easy to understand. The multiple indicating colors can help provide certainty about the fullness of the absorbent article **500**. By knowing the fullness of the absorbent article **500**, the absorbent article **500** can be changed after a wearer has appropriately utilized its capacity and/or before it is likely to leak.

[0105] FIG. 6 illustrates an outside plan view of a portion **608** of an absorbent article **600** laid out flat. In various embodiments, the absorbent article **600** can be a disposable wearable absorbent article, such as a pant-type disposable wearable absorbent article or a front-fastenable disposable wearable absorbent article. For reference, FIG. 6 illustrates a center **619** of the absorbent article **600** and arrows indicating relative directions for outboard **617** and inboard **618** for the absorbent article **600**. The portion **608** includes a first visual fullness indicating area **640**, a second visual fullness indicating area **660**, and a third visual fullness indicating area **680**. Each of the elements of the embodiment of FIG. 6 is configured in the same way as the like-numbered element of the embodiment of FIG. 5, except as noted below.

[0106] In the embodiment of FIG. 6, the second visual fullness indicating area **660** is spaced apart from the first visual fullness indicating area **640** by a separating portion **655**, and the third visual fullness indicating area **680** is spaced apart from the second visual fullness indicating area **660** by a separating portion **675**. In one alternate embodiment, a first visual fullness indicating area can be immediately adjacent to and in contact with a second visual fullness indicating area

while a third visual fullness indicating area is still spaced apart from the second visual fullness indicating area. In another alternate embodiment, a second visual fullness indicating area can be immediately adjacent to and in contact with a third visual fullness indicating area while the second visual fullness indicating area is still spaced apart from a first visual fullness indicating area.

[0107] The first visual fullness indicating area **640**, the second visual fullness indicating area **660**, and the third visual fullness indicating area **680** can change colors progressively and in sequence, as described in connection with the first visual fullness indicating area **540**, the second visual fullness indicating area **560**, and the third visual fullness indicating area **580** of the embodiment of FIG. 5.

[0108] The present disclosure includes wetness indicators with multiple colors that are easy to understand. As a result, these wetness indicators can help provide certainty about the fullness of an absorbent article. By knowing how full the article is, the article can be changed after the wearer has appropriately utilized the capacity of the article. Also, by knowing how full the article is, the article can be changed before it is likely to leak.

[0109] Further, the present disclosure contemplates that an absorbent article, such as a disposable wearable absorbent article, can have one or more visual fullness indicators configured as described herein and further configured with various additional and/or alternate structures and/or functions as described below.

[0110] One or more embodiments of the present disclosure can be combined with one or more embodiments of US non-provisional patent application Ser. No. 12/346,481 entitled "Absorbent Articles with Multiple Indicating Widths," filed on Dec. 30, 2008 under attorney docket number 11218Q and/or U.S. non-provisional patent application entitled "Absorbent Articles with Multiple Indicating Widths," filed on Dec. 23, 2009 under attorney docket number 11218RQ, application Ser. No. 12/646,315, each of which is incorporated herein by reference. A disposable wearable absorbent article with multiple indicating colors can also have multiple indicating widths.

[0111] One or more embodiments of the present disclosure can be combined with one or more embodiments of U.S. non-provisional patent application Ser. No. 12/346,496 entitled "Disposable Wearable Absorbent Articles with Gender Specific Indicia," filed on Dec. 30, 2008 under attorney docket number 11219 and/or US non-provisional patent application entitled "Disposable Wearable Absorbent Articles with Gender Specific Indicia," filed on Dec. 23, 2009 under attorney docket number 11219R, application Ser. No. 12/646,496, each of which is incorporated herein by reference. A disposable wearable absorbent article with multiple indicating colors can also be configured with gender specific indicia.

[0112] One or more embodiments of the present disclosure can be combined with one or more embodiments of U.S. non-provisional patent application Ser. No. 12/346,510 entitled "Disposable Wearable Absorbent Articles with Gender Specific Indicating," filed on Dec. 30, 2008 under attorney docket number 11220 and/or U.S. non-provisional patent application entitled "Disposable Wearable Absorbent Articles with Gender Specific Indicating," filed on Dec. 23, 2009 and further identified by attorney docket number 11220R, application Ser. No. 12/646,345, each of which is

incorporated herein by reference. A disposable wearable absorbent article with multiple indicating colors can also have gender specific indicating.

[0113] One or more embodiments of the present disclosure can be combined with one or more embodiments of U.S. non-provisional patent application Ser. No. 12/346,520 entitled "Absorbent Articles with Patterns of Indicating," filed on Dec. 30, 2008 under attorney docket number 11221Q and/or U.S. non-provisional patent application entitled "Absorbent Articles with Patterns of Indicating," filed on Dec. 23, 2009 under attorney docket number 11221RQ, application Ser. No. 12/646,393, each of which is incorporated herein by reference. A disposable wearable absorbent article with multiple indicating colors can also have patterns of indicating.

[0114] One or more embodiments of the present disclosure can be combined with one or more embodiments of U.S. provisional patent application 61/141,573 entitled "Absorbent Articles with Primary and Secondary Indicating," filed on Dec. 30, 2008 under attorney docket number 11222PQ and/or U.S. non-provisional patent application entitled "Absorbent Articles with Primary and Secondary Indicating," filed on Dec. 23, 2009 under attorney docket number 11222MQ, application Ser. No. 12/646,414, each of which is incorporated herein by reference. A disposable wearable absorbent article with multiple indicating colors can also have primary and secondary indicating.

[0115] One or more embodiments of the present disclosure can be combined with one or more embodiments of U.S. non-provisional patent application entitled "Absorbent Articles with Primary and Secondary Indicia," filed on Dec. 23, 2009 under attorney docket number 11222M2Q, application Ser. No. 12/646,430, which is incorporated herein by reference. A disposable wearable absorbent article with multiple indicating colors can also have primary and secondary indicia.

[0116] The dimensions and values disclosed herein are not to be understood as being strictly limited to the exact numerical values recited. Instead, unless otherwise specified, each such dimension is intended to mean both the recited value and a functionally equivalent range surrounding that value. For example, a dimension disclosed as "40 mm" is intended to mean "about 40 mm."

[0117] Every document cited herein, including any cross referenced or related patent or application, is hereby incorporated herein by reference in its entirety unless expressly excluded or otherwise limited. The citation of any document is not an admission that it is prior art with respect to any invention disclosed or claimed herein or that it alone, or in any combination with any other reference or references, teaches, suggests or discloses any such invention. Further, to the extent that any meaning or definition of a term in this document conflicts with any meaning or definition of the same term in a document incorporated by reference, the meaning or definition assigned to that term in this document shall govern.

[0118] While particular embodiments of the present invention have been illustrated and described, it would be obvious to those skilled in the art that various other changes and modifications can be made without departing from the spirit and scope of the invention. It is therefore intended to cover in the appended claims all such changes and modifications that are within the scope of this invention.

What is claimed is:

1. A disposable wearable absorbent article, comprising:
 - a topsheet;
 - an absorbent core;
 - an outer cover;
 - a waist opening;
 - leg openings;
 - a first visual fullness indicating area configured to change to a first subsequent color when indicating the presence of a bodily exudate, wherein at least a portion of the first visual fullness indicating area is visible from outside of the disposable wearable absorbent article when the article is worn by a wearer; and
 - at least, a second visual fullness indicating area configured to change to a second subsequent color when indicating the presence of a bodily exudate, wherein the second subsequent color is visually distinguishable from the first subsequent color, and wherein at least a portion of the second visual fullness indicating area is visible from outside of the disposable wearable absorbent article when the article is worn by a wearer.
2. The absorbent article of claim 1, wherein the second visual fullness indicating area is outboard from the first visual fullness indicating area.
3. The absorbent article of claim 2, wherein the second visual fullness indicating area is longitudinally outboard from the first visual fullness indicating area.
4. The absorbent article of claim 2, wherein the second visual fullness indicating area is laterally outboard from the first visual fullness indicating area.
5. The absorbent article of claim 1, wherein the second visual fullness indicating area is immediately adjacent to the first visual fullness indicating area.
6. The absorbent article of claim 1, wherein the second visual fullness indicating area is spaced apart from the first visual fullness indicating area.
7. The absorbent article of claim 1, wherein the first visual fullness indicating area has an overall shape that is substantially elongated.
8. The absorbent article of claim 1, wherein the first visual fullness indicating area has a substantially uniform width.
9. The absorbent article of claim 1, wherein the second visual fullness indicating area has an overall shape that is substantially elongated.
10. The absorbent article of claim 1, wherein the second visual fullness indicating area has a substantially uniform width.
11. The absorbent article of claim 1, wherein an overall length of the second visual fullness indicating area is less than an overall length of the first visual fullness indicating area.
12. The absorbent article of claim 1, wherein the first subsequent color is selected from the group including: the color green, a variation of the color green, the color blue, a variation of the color blue, the color purple, and a variation of the color purple.
13. The absorbent article of claim 1, wherein the second subsequent color is selected from the group including: the color yellow, a variation of the color yellow, the color orange, a variation of the color orange, the color red, and a variation of the color red.
14. The absorbent article of claim 1, including, at least, a third visual fullness indicating area, configured to change to a third subsequent color when indicating the presence of a

bodily exudate, wherein the third subsequent color is visually distinguishable from the second subsequent color.

15. The absorbent article of claim **14**, wherein the third visual fullness indicating area is outboard from the second visual fullness indicating area.

16. The absorbent article of claim **14**, wherein the third visual fullness indicating area is immediately adjacent to the second visual fullness indicating area.

17. The absorbent article of claim **14**, wherein the third visual fullness indicating area is spaced apart from the second visual fullness indicating area.

18. The absorbent article of claim **14**, wherein the third subsequent color is selected from the group including: the color yellow, a variation of the color yellow, the color orange, a variation of the color orange, the color red, and a variation of the color red.

* * * * *