



US 20170023337A1

(19) **United States**

(12) **Patent Application Publication**
Krywonizka

(10) **Pub. No.: US 2017/0023337 A1**

(43) **Pub. Date: Jan. 26, 2017**

(54) **EXPLODING TARGET**

(52) **U.S. Cl.**

CPC *F41J 5/26* (2013.01)

(71) Applicant: **Gryphon Energetics Inc.**, Winnipeg
(CA)

(57) **ABSTRACT**

(72) Inventor: **Andrew M. Krywonizka**, Winnipeg
(CA)

An exploding target features a hard-walled container containing ammonium nitrate therein and a flexible bag containing particulate aluminum therein disposed in the container. An explosive mixture is formed by mixing the oxidizing and sensitizing components in the container according to one aspect of the invention. In another aspect of the invention, each pair of opposing upstanding container walls are in parallel relation thereto and have uniform spacing therebetween from the bottom to the top thereof so that the amount of explosive mixture contained between each pair of opposing walls along the depth thereof is uniform across the surface area of each wall. In a further aspect, each wall has a visually distinguishable feature for distinguishing from the other walls and from the external environment. In a further aspect of the invention, the aluminum comprises a combination of fine and coarse grades of aluminum particles for improving sensitivity to bullet impact.

(21) Appl. No.: **15/040,341**

(22) Filed: **Feb. 10, 2016**

(30) **Foreign Application Priority Data**

Apr. 7, 2015 (CA) 2887007

Publication Classification

(51) **Int. Cl.**
F41J 5/26 (2006.01)

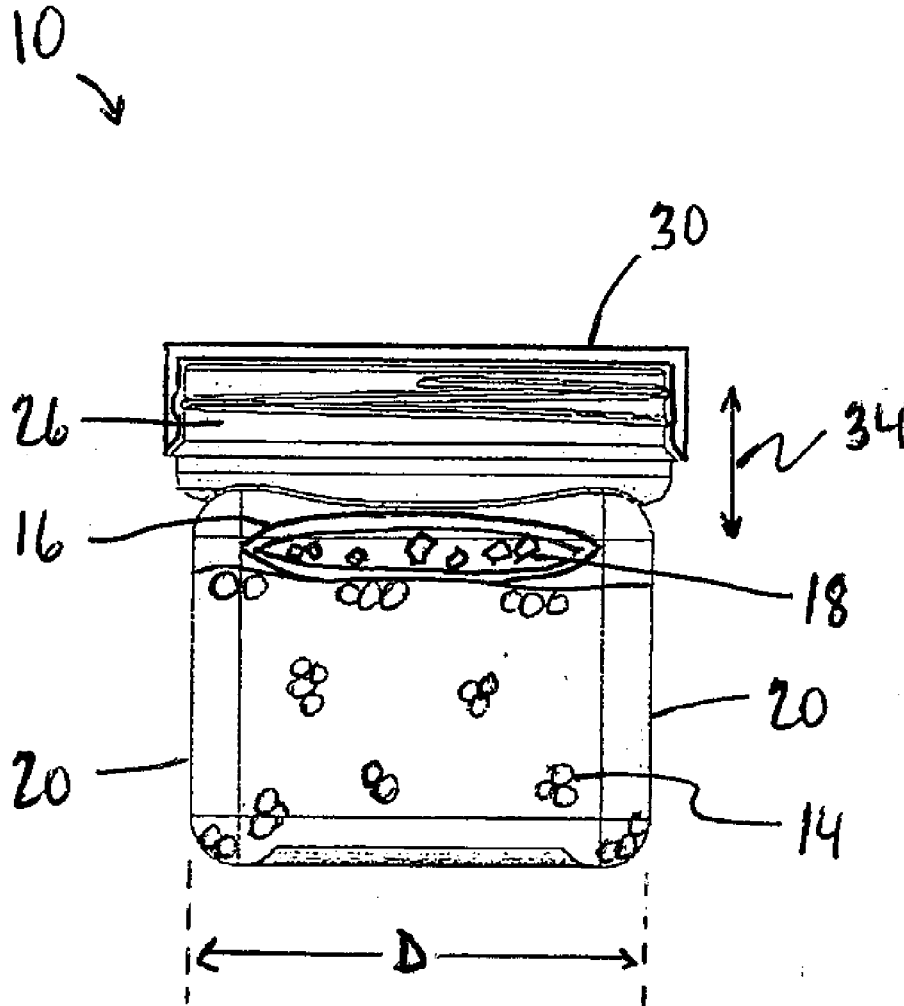

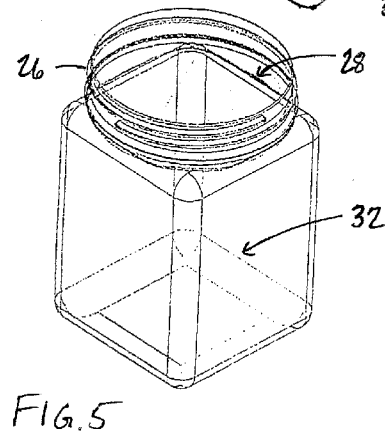
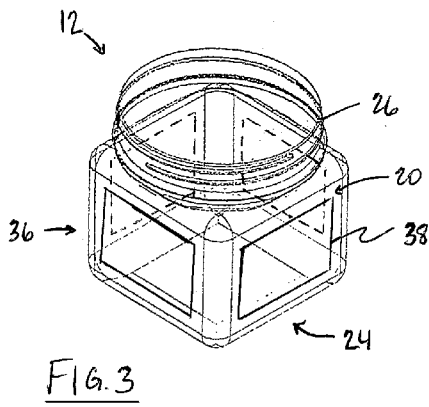
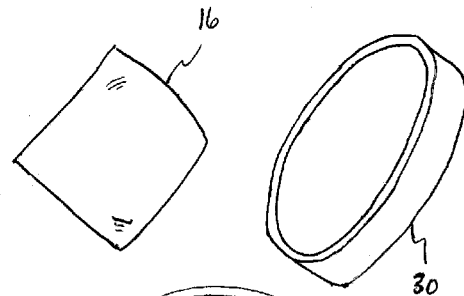
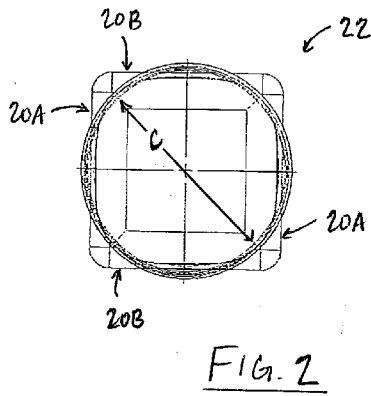
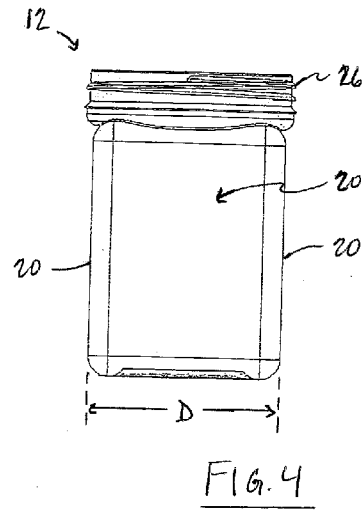
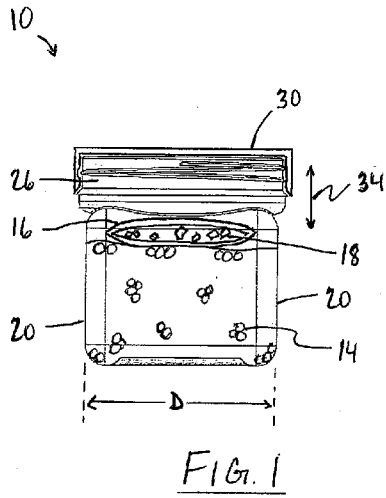

EXPLODING TARGET

[0001] This application claims the benefit of Canadian Patent Application 2,887,007 filed Apr. 7, 2015.

FIELD OF THE INVENTION

[0002] The present invention relates generally to binary exploding targets, and more particularly the present invention relates to an arrangement of binary exploding targets having more reliable performance and greater sensitivity to smaller and/or slower travelling bullets.

BACKGROUND

[0003] Exploding targets for use in shooting exercises with firearms are available from a variety of companies including Tannerite Brand Binary Rifle Targets (“Tannerite”) and Sure Shot Exploding Targets (“Sure Shot”). These targets are typically sold in a package comprising at least two containers with one of these containing an oxidizing component and another one containing a sensitizing component. (The industry term usually used for the sensitizing component is ‘catalyst’; however, ‘catalyst’ is not a technically correct term for this reaction ingredient as the sensitizing component is consumed in the reaction.) Since the target comprises two primary ingredients these exploding targets are often called “binary exploding targets”, and it is essential that these two components are kept separate from one another prior to actual use of the target. When mixed together, the resulting mixture is explodable subject to a sufficing impact from a bullet. Such exploding targets may be used in exercises training target acquisition, target aiming, and target differentiation.

[0004] One potential shortcoming of the exploding targets presently available on the market is that the target container, in which the explosive mixture is stored upon use of the target in the shooting exercise, comprises opposing upstanding walls which have a non-uniform depth therebetween horizontally across the face of each wall. Examples of such target containers are a round cylindrical container and a rectangular container having a pinch grip formed in one wall. Consequently, assuming that a bullet penetrates a first wall of the target container at a right angle the amount of the explosive mixture through which the bullet passes will vary depending upon the location of impact on the face of the first wall, and consequently the explosive effect will vary too.

[0005] Another potential shortcoming of known exploding target products is that each product is manufactured in target containers of identical appearance such that a plurality of targets defined by multiple such target containers are not readily differentiable. Furthermore, as these exploding targets are typically used outdoors the target containers blend in with the surrounding external environment.

[0006] Yet another potential shortcoming is that known products of exploding targets are packaged in multiple hard-walled containers, which increases the cost of each product and augments the waste generated thereby when the product is fully used. In other instances, known products such as Sure Shot are packaged as a single hard-walled container containing multiple bags therein and the multiple bags respectively containing the two primary ingredients therein. The respective bag containing the oxidizing component therein is used as a mixing container for mixing the two components after which the explodable mixture resulting therefrom is transferred to the hard-walled container. As

such, the additional bags similarly contribute to augmented amounts of waste generated by use of the product and may also increase the cost of the product.

[0007] A further potential shortcoming is that known formulas of exploding targets, as the one taught in U.S. Pat. No. 6,848,366 to Tanner, include compounds which have been found unnecessary to induce detonation of ammonium nitrate, which is typically used as the oxidizing component of the exploding targets. Inclusion of unnecessary compounds increases the cost of materials for each product and the labour required to manufacture same.

[0008] Yet a further potential shortcoming of the exploding targets is that the products presently available are suited for use with a limited range of calibers which are required to be of a sufficing size to detonate the target. Moreover, a minimum bullet velocity is needed to detonate the target thereby limiting the range distance over which the product can be used before the bullet has lost a portion of its velocity and is consequently no longer able to effect detonation.

[0009] The applicant provides a unique exploding target which seeks to improve upon known related products and to overcome the potential shortcomings thereof.

SUMMARY OF THE INVENTION

[0010] According to one aspect of the invention there is provided an exploding target for a shooting exercise comprising:

[0011] a first hard-walled container defining a target of the shooting exercise, the first hard-walled container comprising:

[0012] a plurality of upstanding container walls defining an outer container periphery;

[0013] a container base at a bottom of the walls;

[0014] a container neck at a top of the walls delimiting a container opening; and

[0015] a container cap removably attached on the neck across the opening;

[0016] a first oxidizing component contained in the hard-walled container;

[0017] a second container containing a second sensitizing component therein;

[0018] the first oxidizing component and the second sensitizing component being combinable to form an explosive mixture storable in the hard-walled container;

[0019] the container walls comprising an even number of walls arranged on the container base such that the outer container periphery is defining a polygon having the even number of sides, each pair of the sides directly opposite one another being in parallel relation and having equal length; and

[0020] at least one pair of opposing container walls corresponding to at least one pair of the sides which are directly opposite one another having uniform spacing therebetween from the bottom to the top thereof.

[0021] The embodiment as described in more detail hereinafter provides the hard-walled container with a plurality of opposing parallel container walls which have uniform spacing therebetween such that the amount of the explosive mixture, through which a bullet passes in its path substantially at right angles to the parallel container walls defining the target surfaces, is equal regardless of the location of impact on respective outer faces of either one of the walls. More particularly, each pair of such parallel container walls has the uniform spacing across a surface area of either one

of the walls such that the amount of explosive mixture between the pair of walls as measured along the depth therebetween is equal across the surface area of either wall. Therefore, reliability of explosive effect of the explosive mixture may be improved, and likelihood of misfires as a result of striking the target surface at any location away from its center may be reduced. "Reliability" refers to consistency in performance where performance is measured particularly in terms of one or any combination of the following: concussive effect of the detonation of the explosive mixture (i.e., a shockwave transmitted after detonation); visual effect including fireball and smoke cloud; audible effect including the boom following the detonation; and consistency in initiating detonation that is related to reduced likelihood of misfires in which the exploding target fails to detonate properly. The performance of the target may also include other aspects of the functioning of exploding targets which are important as determined by one with normal skill in the art.

[0022] "Container neck" refers to a portion of the container delimiting the container opening and which does not necessarily have a smaller diameter than a diameter or depth between the upstanding container walls.

[0023] Preferably, the sides of the polygon have uniform length and each pair of adjacent polygon sides has substantially equal interior angles formed therebetween such that each polygon side is in the opposing parallel relation to another one of the sides, and each pair of opposing container walls corresponding thereto has uniform wall spacing therebetween from the bottom to the top thereof.

[0024] Preferably, the polygon comprises one of a rectangle and a square. In the case of a rectangle, the exploding target may contain a first depth of the explosive mixture between a first pair of upstanding container walls and a second depth of the explosive mixture between a second pair of the container walls. Each depth of the explosive mixture provides a different degree of the performance of the exploding target as described earlier. In another instance, the polygon comprises one of a hexagon and octagon.

[0025] According to another aspect of the invention there is provided an exploding target for a shooting exercise comprising:

[0026] a first hard-walled container defining a target of the shooting exercise, the first hard-walled container comprising:

[0027] a plurality of upstanding container walls defining an outer container periphery;

[0028] a container base at a bottom of the walls;

[0029] a container neck at a top of the walls delimiting a container opening; and

[0030] a container cap removably attached on the neck across the opening;

[0031] a first oxidizing component contained in the hard-walled container;

[0032] a second container containing a second sensitizing component therein;

[0033] the first oxidizing component and the second sensitizing component being combinable to form an explosive mixture storable in the hard-walled container;

[0034] at least two container walls respectively comprising a visually distinguishable feature distinguishing one of said at least two walls from another one of said at least two walls.

[0035] By distinguishing one container wall from another using visually distinguishable features such as different contrasting hues or distinguishable patterns, multiple such exploding targets can be located side-by-side in the shooting exercise and oriented such that the contrasting hues may aid a single shooter or multiple shooters in target identification and target distinction. That is, the single shooter may be able to more easily keep track of the exploding targets that have been struck or the visually distinguishable features may allow for easier execution of more elaborate shooting exercises in which the exploding targets are to be struck in a particular order. Furthermore, the visually distinguishable features may be designed or selected such that the exploding target can be clearly distinguished from backgrounds formed by external outdoor environments like sand, greenery, and/or trees, as the exploding target is typically suited for use outdoors. In addition to aiding target identification among the external environment surrounding the exploding target, the visually distinguishable features of the walls may allow the shooter to more readily see the target to ascertain whether it has been detonated prior to approaching same.

[0036] In one instance, the at least two walls respectively having the visually distinguishable features comprises two container walls which are adjacent. Depending on an orientation of the target surfaces towards the shooter, the adjacent walls having the visually distinguishable features can be oriented so as to simultaneously face the shooter for a shooting exercise developed for training aiming. In another instance, the at least two walls respectively having the visually distinguishable features comprises all of the upstanding container walls. The visually distinguishable features may be defined by labels adhered to the container walls or may be formed into the container walls by the material from which the walls are manufactured. The visually distinguishable features may include at least one of patterns, symbols, characters, numbers, contrasting hues, and colour gradients which may increase the number of possible visually distinguishable features suited for the aforementioned purposes of the arrangement according to the present aspect including target differentiation and identification. Generally speaking, the visually distinguishable feature comprises a feature added to an unadorned, uncoloured container wall. Typically, the container walls are transparent or translucent.

[0037] To help in distinguishing from an environment external to the hard-walled container that is typically outdoors, the visually distinguishable feature of at least one of said at least two container walls in one instance comprises a vibrant colour including one of cyan, magenta, yellow, and a mixed colour integrating at least two of those colours. "Vibrant colour" refers to a colour having high intensity, like a saturated colour. In another instance, the visually distinguishable feature comprises a vibrant colour having fluorescence. Any combination or mixture of the foregoing vibrant colours can be used to distinguish the hard-walled container from the external environment. Moreover, the "vibrant colours" are a subset of "contrasting hues" which also includes other types of colours, shades, or tints serving the aforementioned purposes of distinguishing between container walls and from the external environment.

[0038] According to a further aspect of the invention there is provided an exploding target for a shooting exercise comprising:

[0039] a first hard-walled container defining a target of the shooting exercise, the first hard-walled container comprising:

[0040] a plurality of upstanding container walls defining an outer container periphery;

[0041] a container base at a bottom of the walls;

[0042] a container neck at a top of the walls delimiting a container opening; and

[0043] a container cap removably attached on the neck across the opening;

[0044] a first oxidizing component contained in the hard-walled container;

[0045] a second container containing a second sensitizing component therein;

[0046] the first oxidizing component and the second sensitizing component being combinable to form an explosive mixture storable in the hard-walled container;

[0047] the first sensitizing component comprising ammonium nitrate;

[0048] the second sensitizing component comprising aluminum particles;

[0049] wherein the aluminum particles comprise a combination of different particle grades, the particles grades including a fine size and a coarse size in which the coarse size is larger than the fine size.

[0050] By combining different particle grades of the aluminum particles, sensitivity of the explosive mixture to smaller caliber and/or relatively low velocity bullets may be improved. That is, the smaller fine size of aluminum particles, which have lower activation energy than the larger coarse size of aluminum particles, are introduced such that the smaller caliber and/or lower velocity bullets provide sufficing energy to initiate detonation of the explosive mixture. Consequently, a broader range of calibers may be suited for detonating the target, and the target may also be detonated at larger distances or longer ranges between the shooter and the target compared to the prior art since the loss of velocity and consequently the energy of the bullet is compensated by the lower activation energy required for detonation. Moreover, keeping the larger, coarse size of aluminum particles together with the fine grade of the aluminum particles provides the desired sensitivity; lowers cost of producing each target since the coarse size is less expensive to manufacture than the fine size; and also provides an acceptable concussive effect which is more dependent upon total amounts of aluminum in the explosive mixture and less critical of particle size.

[0051] In one instance, the fine size comprises an average particle dimension between 0.5 and 15 microns. In another instance, the fine size comprises the average particle dimension between 1 and 10 microns. In a further instance, the fine size comprises the average particle dimension between 3 and 8 microns. An example of the fine grade is Toyal grade 105 aluminum particles having a 5 micron average particle dimension.

[0052] In one instance, the coarse size comprises an average particle dimension between 16 and 120 microns. In another instance, the coarse size comprises the average particle dimension between 20 and 100 microns. In a further instance, the coarse size comprises the average particle dimension between 25 and 80 microns. An example of the coarse grade is Toyal grade 101 aluminum particles having a 30 micron average particle dimension.

[0053] Regardless of the grade, the aluminum particles may be spherical, spheroidal (i.e., nodular), or flake in shape.

[0054] In either case of the fine or coarse size, "average particle dimension" refers generally to an average of respective maximum dimensions of the respective aluminum particles measured on the respective particle in any direction since the particles may be of a variety of shapes. That is, the maximum dimension of each aluminum particle of the particular grade is averaged for all of the aluminum particles of that particular grade.

[0055] In one instance, the combination of aluminum particles comprises a prescribed ratio between the fine and coarse sizes in which the fine size is in a range between 2% and 55% by weight and the coarse size is in a range between 45% and 98% by weight. "By weight" refers to portioning relative to a total weight or mass of the particular substance in question which in this case is all the aluminum particles, regardless of grade. In another instance, the prescribed ratio between the fine and coarse sizes is defined by the fine size in a range between 5% and 50% by weight and the coarse size in a range between 50% and 95% by weight. In yet another instance, the prescribed ratio between the fine and coarse sizes is defined by the fine size being in a range between 7% and 35% by weight and the coarse size being in a range between 65% and 93% by weight. In a further instance, the prescribed ratio between the fine and coarse sizes is defined by the fine size being in a range between 8% and 20% by weight and the coarse size being in a range between 80% and 92% by weight.

[0056] According to a further aspect of the invention there is provided an exploding target for a shooting exercise comprising:

[0057] a first hard-walled container defining a target of the shooting exercise, the first hard-walled container comprising:

[0058] a plurality of upstanding container walls defining an outer container periphery;

[0059] a container base at a bottom of the walls;

[0060] a container neck at a top of the walls delimiting a container opening; and

[0061] a container cap removably attached on the neck across the opening;

[0062] a first oxidizing component contained in the hard-walled container;

[0063] a second container containing a second sensitizing component therein;

[0064] the first oxidizing component and the second sensitizing component being combinable to form an explosive mixture storable in the hard-walled container;

[0065] the first sensitizing component comprising ammonium nitrate;

[0066] the second sensitizing component comprising particulate aluminum;

[0067] wherein the explosive mixture comprises a prescribed ratio between the ammonium nitrate and the particulate aluminum in which the ammonium nitrate is in a range between 85% and 99% by weight and the particulate aluminum is in a range between 1% and 15% by weight.

[0068] In this arrangement, the ammonium nitrate as the oxidizing component defines the chief or primary explosive component of the explosive mixture and the aluminum as the sensitizing component defines the fuel of the explosive mixture required to detonate the ammonium nitrate. This

arrangement omits other ingredients included in the prior art such as ammonium perchlorate, titanium, and zirconium hydride which are not necessary to effect detonation of ammonium nitrate when subjected to the impact of a bullet of sufficing velocity. As such, this arrangement provides a simpler formula for the explosive mixture which may be of lower cost to produce than the prior art in terms of both material costs for the required ingredients and labour costs to prepare the formula. Also, the prescribed ratio between the ammonium nitrate and the particulate aluminum provides more powerful detonations which may increase the concussive impulse (i.e., shockwave) felt by the shooter compared to that of the prior art. Furthermore, this prescribed ratio provides the desired sensitivity to relatively low energy bullet impacts with the desired concussive effects. Since hearing protection is often used when discharging a firearm, sufficing concussive impacts generated by the detonation of the target provide the user with a tactile or haptic feedback of the detonation in addition to the visual effects and the audible effects which are typically muted by the hearing protection worn by the user.

[0069] Preferably, the prescribed ratio comprises an optimal ratio in which each of the ammonium nitrate and the particulate aluminum are in respective optimal ranges. In one instance, the ammonium nitrate is in an optimal range between 90% and 98% by weight and the particulate aluminum is in an optimal range between 2% and 10% by weight. In another instance, the ammonium nitrate is in an optimal range between 91% and 96% by weight and the particulate aluminum is in an optimal range between 4% and 9% by weight.

[0070] According to a further aspect of the invention there is provided a method of preparing an exploding target for a shooting exercise comprising:

[0071] providing a first hard-walled container and a second container comprising:

[0072] the first hard-walled container defining a target of the shooting exercise and comprising:

[0073] a plurality of upstanding container walls defining an outer container periphery;

[0074] a container base at a bottom of the walls;

[0075] a container neck at a top of the walls delimiting a container opening; and

[0076] a container cap removably attached on the neck across the opening;

[0077] a first oxidizing component contained in the hard-walled container;

[0078] a second sensitizing component contained in the second container;

[0079] the first oxidizing component and the second sensitizing component being combinable to form an explosive mixture storable in the hard-walled container;

[0080] transferring the sensitizing component into the hard-walled container to form an aggregate of the oxidizing and sensitizing components;

[0081] mixing the oxidizing and sensitizing components in the hard-walled container so as to form the explosive mixture.

[0082] In this arrangement, the explosive mixture is prepared by mixing the constituent oxidizing and sensitizing components directly in the hard-walled container which is adapted therefor. As opposed to the prior art, in which a third container and funnel are provided for forming the exploding

target, the present arrangement may reduce waste produced thereby as fewer items are required in order to prepare the exploding target.

[0083] Preferably, the second container comprises a flexible bag disposed in the hard-walled container. Preferably, the flexible bag is sized for passing through the opening of the hard-walled container. This arrangement may further decrease waste over the prior art in which two hard-walled containers are provided as part of the package to form the exploding target.

[0084] It is preferred that the hard-walled container is sized to provide a sufficing air gap between the aggregate of the oxidizing and sensitizing components received therein prior to mixing and the opening of the hard-walled container such that the hard-walled container is adapted for the step of mixing the oxidizing and sensitizing components directly in the container. Preferably, the sufficing air gap comprises a gap measured in a direction from the container base towards the opening generally between the aggregate and one of the container base and the opening. It is preferred that the gap comprises a prescribed range between 5 millimetres and 30 millimetres. In one instance, the prescribed range comprises an optimal range between 8 millimetres and 26 millimetres.

[0085] According to a further aspect of the invention there is provided an exploding target for a shooting exercise comprising:

[0086] a first hard-walled container defining a target of the shooting exercise, the first hard-walled container comprising:

[0087] a plurality of upstanding container walls defining an outer container periphery;

[0088] a container base at a bottom of the walls;

[0089] a container neck at a top of the walls delimiting a container opening; and

[0090] a container cap removably attached on the neck across the opening;

[0091] a first oxidizing component contained in the hard-walled container;

[0092] a second container containing a second sensitizing component therein;

[0093] the first oxidizing component and the second sensitizing component being combinable to form an explosive mixture storable in the hard-walled container;

[0094] wherein the second container comprises a flexible bag disposed in the hard-walled container.

[0095] Note that any or all of the forgoing features of the present invention may be combined.

BRIEF DESCRIPTION OF THE DRAWINGS

[0096] Preferred embodiments of the invention will now be described in conjunction with the accompanying drawings in which:

[0097] FIG. 1 is a schematic representation of the exploding target of a first embodiment.

[0098] FIG. 2 is a top plan view of the hard-walled container of FIG. 1 with the cap and internal contents of the hard-walled container removed.

[0099] FIG. 3 is a perspective view of the hard-walled container of FIG. 1 with the contrasting hues schematically illustrated on the walls of the hard-walled container and omitting the internal contents thereof and the cap.

[0100] FIG. 4 is a side-elevation view of another, volumetrically larger hard-walled container of a second embodiment.

[0101] FIG. 5 is a perspective view of the hard-walled container of FIG. 4 including the cap and the flexible bag.

[0102] In the drawings like characters of reference indicate corresponding parts in the different figures.

DETAILED DESCRIPTION

[0103] Referring to the accompanying figures, there is illustrated an exploding target generally indicated by reference numeral 10. The exploding target is suited for shooting exercises with firearms. The exploding target is arranged to detonate upon striking of a bullet fired by a firearm.

[0104] The exploding target comprises a hard-walled container 12 containing a first oxidizing component 14 therein. The target also includes a flexible bag 16 disposed in the hard-walled container and containing a second sensitizing component 18 therein. The oxidizing and sensitizing components are mixed together to form an explosive mixture which is explodable subject to a sufficing impact from the bullet.

[0105] Turning now in more detail to the hard-walled container, the hard-walled container 12 comprises a plurality of upstanding container walls 20 defining a square outer periphery 22 that encloses an upstanding axis of the container. The hard-walled container further comprises a base 24 at the bottom of the walls closing the bottom end of the walls. Additionally, the hard-walled container includes a circular neck 26 at the top of the walls opposite the base 24 and extending away from the walls along the upstanding axis of the container. The neck is round cylindrical in form or shape and has a neck diameter "C" substantially equal to a spacing "D" between each pair of walls 20A, 20B in opposing parallel relation to one another. An opening 28 over the square outer periphery 22 is delimited by the top end of the neck. Furthermore, the neck is threaded along a circular outer periphery thereof for securely receiving a threaded container cap 30 on the neck across the opening such that the upstanding container walls 20 are closed generally at the top end of the walls by the cap. In the illustrated embodiments, the container walls, base, and neck are a solid unitary piece and are manufactured from plastic; however, other manufacturing arrangements such that the walls, base, and neck are not made in one solid piece and other materials may be used. Moreover, each of the walls, the base, and the neck are transparent in the illustrated embodiments. Additionally, two different container sizes are illustrated in the accompanying figures as two separate embodiments. The containers of both embodiments are identical except that the container of the second embodiment is sized volumetrically larger than that of the first embodiment. The larger volume container of the second embodiment can store a larger amount of explosive mixture than the smaller volume container of the first embodiment thereby augmenting explosive effects produced by the explosive mixture including a shockwave or concussive impulse; visual effects such as a fireball and smoke cloud; and an audible boom. As such, all of the following features in the remainder of this specification are common to both embodiments.

[0106] The hard-walled container 12 stores the explosive mixture 32 formed by mixing the oxidizing 14 and sensitizing 18 components. Consequently, the container is sized

for storing the explosive mixture therein and is also sized for mixing the two constituent components directly in the hard-walled container. More particularly, the container is sized to provide a sufficing air gap 34 between an aggregate of the oxidizing and sensitizing components received therein and the opening of the hard-walled container prior to mixing. The air gap more generally comprises a gap measured in the axial direction of the container. This gap 34 is in a prescribed range between 5 millimetres and 30 millimetres to provide sufficient space in the hard-walled container for thoroughly and properly mixing the aggregate to form the explosive mixture. This gap may also lie in a smaller prescribed range between 8 millimetres and 26 millimetres and function equally as well as the forgoing range of 5 to 30 millimetres. In the illustrated embodiments, the neck 26 of the container defines a portion of the gap 34 because the neck diameter "C" is sized substantially equal to the spacing "D" between opposing walls 20A, 20B thereby defining a continuation or extension of the upstanding container walls towards the opening in the container. Moreover, the gap is defined and is of comparable size regardless of whether the container is oriented such that the neck is above the base or the base is above the neck. In either orientation, the aggregate can be properly mixed.

[0107] Since the hard-walled container is suited for storing the explosive mixture therein, each upstanding wall defines a potential target surface 36 of the shooting exercise such that the hard-walled container is generally to be struck by the bullet to detonate the target. As such, each outer face of respective upstanding walls comprises a label 38 schematically illustrated in FIG. 3 that is adhered to each wall and that has a contrasting hue different from the other labels. Each label comprises a vibrant colour including one of cyan, magenta, yellow, and a mixed colour integrating at least two of those colours; however, other vibrant colours may also be used. The differently coloured walls allow a user to orient the hard-walled container such that the desired target surface facing the user is readily distinguishable from an external environment surrounding the hard-walled container thereby aiding in the exercise of target identification and acquisition. Furthermore, several hard-walled containers respectively storing the explosive mixture can be disposed generally side-by-side and oriented with a different coloured wall face towards the shooter or multiple shooters so that the multiple targets are readily differentiable thereby aiding in the exercise of target differentiation. Note that in other embodiments, the vibrant colour has fluorescence to further aid in distinguishing the respective wall face from the surroundings of the container. As such, the contrasting hues of the illustrated embodiments define visually distinguishable features of the container walls that distinguish one container wall from another and that distinguish the walls from the surroundings of the container.

[0108] The square outer periphery substantially defines a polygon 22—which in the case of the illustrated embodiments is a square or more generally a rectangle—having sides of uniform length and equal interior angles therebetween. The square outer periphery has uniform depth between opposing walls from the bottom to the top thereof. As such, an amount of explosive mixture along a depth dimension "D" of the container, generally measured as a perpendicular distance between the opposing walls 20A or 20B, is substantially equal at any location along a surface area of the respective opposing walls. Thus, the bullet hitting

the desired target surface that is defined by one of the opposing walls traverses the same amount of the explosive mixture from the target surface to the wall in opposite relation thereto regardless of where the bullet is striking the target surface. Consequently, the uniform depth provided by the square outer periphery may afford reliable performance of the exploding target regardless of striking location on the target surface and may also reduce occurrence of misfires when the striking location is not central on the target surface. Additionally, the square outer periphery of the container affords the performance of the exploding target to be consistent irrespective of the specific upstanding container that is defining the desired target surface because the depth "D" between all pairs of opposing parallel walls 20A, 20B is uniform at all points along the surface area of each respective wall of each pair.

[0109] Turning now to the constituent components of the explosive mixture in more detail, the oxidizing component ("oxidizer") 14 comprises ammonium nitrate typically in solid crystalline form and the sensitizing component ("sensitizer") 18 comprises aluminum in particulate form. The ammonium nitrate defines the primary explosive component of the explosive mixture, and the aluminum defines the fuel of the explosive mixture required to detonate the ammonium nitrate. To maximize performance of the mixture, especially in terms of strong concussive effects that are highly desirable, while balancing the performance and cost of the exploding target product, the explosive mixture 32 comprises an optimal ratio between the ammonium nitrate 14 and the aluminum 18. Ideally, the optimal ratio comprises the ammonium nitrate in an amount between 91% and 96% by weight (of the explosive mixture) and the aluminum in an amount between 4% and 9% by weight. The optimal ratio falls within a first prescribed ratio between the ammonium nitrate and aluminum having larger tolerance than the optimal ratio in which performance of the target and cost is still close to that of the optimal ratio. The first prescribed ratio comprises the ammonium nitrate in the amount between 90% and 98% by weight and the aluminum in an amount between 2% and 10% by weight. Furthermore, the first prescribed ratio falls within a second prescribed ratio between the constituent components of the explosive mixture having slightly larger tolerance than the first prescribed ratio in which performance of the target is still acceptably strong and the cost of the target is balanced thereby. The second prescribed ratio comprises the ammonium nitrate in the amount between 85% and 99% by weight and the aluminum in an amount between 1% and 15% by weight. As indicated by the forgoing ratios, the explosive mixture includes the ammonium nitrate in significantly greater amounts than the aluminum particles. For this reason, the ammonium nitrate 14 is contained in the hard-walled container 12 which is much larger in size (i.e., volume) than the flexible bag 16 in which the aluminum 18 is contained. Moreover, the flexible bag is sized to pass through the opening 28 of the container so that the flexible bag can be removed from the container and the aluminum transferred to the hard-walled container for mixing with the ammonium nitrate.

[0110] Turning now to the aluminum, the aluminum 18 is typically manufactured as a powder, though any particulate form of aluminum may be used. The aluminum powder comprises a combination of different particle grades, wherein "grade" refers generally to sizes of the particles, for

improving sensitivity of the aluminum to lower energy impacts. That is, smaller sized aluminum particles have a lower activation energy such that the bullet striking the desired target surface with lower energy still has sufficient energy to initiate detonation. The lower energy of the bullet may be associated with at least one of its size, typically referred to a caliber of the bullet, and its velocity which is based on both the firearm from which the bullet is fired and a distance between the shooter and the target since the bullet loses some of its velocity as it travels from the shooter to the target. Thus, the particle grades of aluminum include a fine size and a coarse size in which the coarse size is larger than the fine size of particulate aluminum. Including both the fine and coarse sizes provides desired sensitivity, since the sensitivity is primarily dependent on particle grade or size, while balancing the cost of the exploding target. The fine size comprises an average particle dimension in a first fine prescribed range between 0.5 and 15 microns, and any size within this range functions acceptably. Note that average particle dimension refers generally to an average of maximum dimensions of the respective aluminum particles measured on the respective particle in any direction as the aluminum particles may be spherical, spheroidal (i.e., nodular), or flake in shape. The coarse size comprises an average particle dimension in a first coarse prescribed range between 16 and 120 microns, and any size within this range functions acceptably. Further to the particle size, the particulate aluminum comprises a prescribed ratio between the fine and coarse sizes of the aluminum particle grades to balance the desired sensitivity and the cost of the target. The fine size aluminum powder provides stronger concussive effects at detonation in smaller amounts relative to the ammonium nitrate than the coarse size aluminum particles, which has to be provided in larger amounts to provide similar concussive effects to the smaller amounts of fine size aluminum powder; however, the fine size is more expensive than the coarse grade. Ideally, the prescribed ratio comprises the fine size in a range between 5% and 50% by weight (of the aluminum) and the coarse size in a range between 50% and 95% by weight. As compared to the ideal prescribed ratio, the fine size may also be in a slightly larger range between 2% and 55% by weight and the coarse size in a slightly smaller range between 45% and 98% and still provide approximately the same desired sensitivity at a comparable cost to the ideal prescribed ratio. Moreover, the fine size may be in a range between 7% and 35% by weight and the coarse size in a range between 65% and 93% by weight to achieve the balance of sensitivity and cost.

[0111] In use, the exploding target is sold as a package comprising the hard-walled container 12 with the oxidizer 14 contained therein. The package includes the flexible bag 16, which contains the sensitizer 18 therein, disposed in the hard-walled container. Upon opening the hard-walled container by removing the cap 30 from the container neck 26, the flexible bag is removed from within the container. The sensitizer 18 is then transferred from the flexible bag 16 into the hard-walled container 12 to form the aggregate of the oxidizing and sensitizing components. The cap 30 is then replaced on the neck 26 and the explosive mixture 32 is formed by mixing the constituent components thereof in the hard-walled container. Mixing is achieved by generally shaking the container and can also be done by inverting the container several times. The sufficing air gap 34 in the hard-walled container provides sufficient space for the

ammonium nitrate and aluminum particles to move around within the hard-walled container so that the aluminum particle can be thoroughly and properly mixed in between the ammonium nitrate crystals. Transparency of the walls, base, and neck allow the user to ascertain when the components can be considered to be thoroughly mixed. Furthermore, since the package of the illustrated embodiments includes the hard-walled container and the flexible bag as the sole containers, preparation time for forming the explosive mixture is relatively quick as only two containers need to be opened to transfer contents. Once the explosive mixture is prepared, the flexible bag may be disposed in a waste container. The explosive mixture 32 is stored in the hard-walled container 12 for detonation therein.

[0112] The hard-walled container storing the explosive mixture therein is arranged at a distance away from a location where the shooter is intended to fire the bullet at the container so as to define a target of the shooting exercise. The hard-walled container may be oriented such that the target surface 36 facing the shooter is readily distinguishable from the surroundings of the container based on the contrasting hue of the target surface. The bullet is fired at the target surface effecting detonation of the explosive mixture upon impact of the bullet. The detonation produces an audible boom, a visible fireball and smoke cloud, and a shockwave which may be felt by the shooter. Sensing the shockwave, which is the primary tactile or concussive effect of the exploding target, is important for recognizing that the target has been detonated since the audible boom is muted by hearing protection typically worn by shooters. Moreover, recognition that the target has detonated is a precautionary measure for ensuring that a live, undetonated target is not approached by the user, and successful detonation can be indicated by any one of the visual, audible, or concussive effects of the explosion or by ascertaining the location or presence of the target which is more easily identifiable with its coloured faces.

[0113] Since various modifications can be made in my invention as herein above described, and many apparently widely different embodiments of same made, it is intended that all matter contained in the accompanying specification shall be interpreted as illustrative only and not in a limiting sense.

1. An exploding target for a shooting exercise comprising:
 - a first hard-walled container defining a target of the shooting exercise, the first hard-walled container comprising:
 - a plurality of upstanding container walls defining an outer container periphery;
 - a container base at a bottom of the walls;
 - a container neck at a top of the walls delimiting a container opening; and
 - a container cap removably attached on the neck across the opening;
 - a first oxidizing component contained in the hard-walled container;
 - a second container containing a second sensitizing component therein;
 - the first oxidizing component and the second sensitizing component being combinable to form an explosive mixture storable in the hard-walled container;
 - the container walls comprising an even number of walls arranged on the container base such that the outer container periphery is defining a polygon having the

- even number of sides, each pair of the sides directly opposite one another being in parallel relation and having equal length; and
 - at least one pair of opposing container walls corresponding to at least one pair of the sides which are directly opposite one another having uniform spacing therebetween from the bottom to the top thereof.
2. The exploding target according to claim 1 wherein the sides of the polygon have uniform length and each pair of adjacent polygon sides has substantially equal interior angles formed therebetween such that each polygon side is in the opposing parallel relation to another one of the sides, and each pair of opposing container walls corresponding thereto has uniform wall spacing therebetween from the bottom to the top thereof.
 3. The exploding target according to claim 1 wherein the polygon comprises one of a rectangle and a square.
 4. An exploding target for a shooting exercise comprising:
 - a first hard-walled container defining a target of the shooting exercise, the first hard-walled container comprising:
 - a plurality of upstanding container walls defining an outer container periphery;
 - a container base at a bottom of the walls;
 - a container neck at a top of the walls delimiting a container opening; and
 - a container cap removably attached on the neck across the opening;
 - a first oxidizing component contained in the hard-walled container;
 - a second container containing a second sensitizing component therein;
 - the first oxidizing component and the second sensitizing component being combinable to form an explosive mixture storable in the hard-walled container;
 - at least two container walls respectively comprising a visually distinguishable feature distinguishing one of said at least two walls from another one of said at least two walls.
 5. The exploding target according to claim 4 wherein said at least two walls respectively having the visually distinguishable features comprises two container walls which are adjacent.
 6. The exploding target according to claim 4 wherein said at least two walls respectively having visually distinguishable features comprises all of the upstanding container walls.
 7. The exploding target according to claim 4 wherein the visually distinguishable feature of at least one of said at least two container walls comprises a vibrant colour including one of cyan, magenta, yellow, and a mixed colour integrating at least two of those colours such that the hard-walled container is distinguished from an environment external to the hard-walled container.
 8. The exploding target according claim 4 wherein the visually distinguishable feature of at least one of said at least two container walls comprises a vibrant colour having fluorescence such that the hard-walled container is distinguished from an environment external to the hard-walled container.
 9. An exploding target for a shooting exercise comprising:
 - a first hard-walled container defining a target of the shooting exercise, the first hard-walled container comprising:

a plurality of upstanding container walls defining an outer container periphery;
 a container base at a bottom of the walls;
 a container neck at a top of the walls delimiting a container opening; and
 a container cap removably attached on the neck across the opening;
 a first oxidizing component contained in the hard-walled container;
 a second container containing a second sensitizing component therein;
 the first oxidizing component and the second sensitizing component being combinable to form an explosive mixture storable in the hard-walled container;
 the first sensitizing component comprising ammonium nitrate;
 the second sensitizing component comprising aluminum particles;
 wherein the aluminum particles comprise a combination of different particle grades, the particles grades including a fine size and a coarse size in which the coarse size is larger than the fine size.

10. The exploding target according to claim **9** wherein the fine size comprises an average particle dimension between 0.5 and 15 microns.

11. The exploding target according to claim **9** wherein the fine size comprises an average particle dimension between 1 and 10 microns.

12. The exploding target according to claim **9** wherein the coarse size comprises an average particle dimension between 16 and 120 microns.

13. The exploding target according to claim **9** wherein the coarse size comprises an average particle dimension between 20 and 100 microns.

14. The exploding target according to claim **9** wherein the combination of aluminum particles comprises a prescribed ratio between the fine and coarse sizes in which the fine size is in a range between 2% and 55% by weight and the coarse size is in a range between 45% and 98% by weight.

15. The exploding target according to claim **9** wherein the combination of aluminum particles comprises a prescribed ratio between the fine and coarse sizes in which the fine size is in a range between 5% and 50% by weight and the coarse size is in a range between 50% and 95% by weight.

16. The exploding target according to claim **9** wherein the combination of aluminum particles comprises a prescribed ratio between the fine and coarse sizes in which the fine size is in a range between 7% and 35% by weight and the coarse size is in a range between 65% and 93% by weight.

17. An exploding target for a shooting exercise comprising:

a first hard-walled container defining a target of the shooting exercise, the first hard-walled container comprising:
 a plurality of upstanding container walls defining an outer container periphery;
 a container base at a bottom of the walls;
 a container neck at a top of the walls delimiting a container opening; and
 a container cap removably attached on the neck across the opening;
 a first oxidizing component contained in the hard-walled container;

a second container containing a second sensitizing component therein;
 the first oxidizing component and the second sensitizing component being combinable to form an explosive mixture storable in the hard-walled container;
 the first sensitizing component comprising ammonium nitrate;
 the second sensitizing component comprising particulate aluminum;
 wherein the explosive mixture comprises a prescribed ratio between the ammonium nitrate and the particulate aluminum in which the ammonium nitrate is in a range between 85% and 99% by weight and the particulate aluminum is in a range between 1% and 15% by weight.

18. The exploding target according to claim **17** wherein the prescribed ratio comprises an optimal ratio in which the ammonium nitrate is in an optimal range between 90% and 98% by weight and the particulate aluminum is in an optimal range between 2% and 10% by weight.

19. The exploding target according to claim **17** wherein the prescribed ratio comprises an optimal ratio in which the ammonium nitrate is in an optimal range between 91% and 96% by weight and the particulate aluminum is in an optimal range between 4% and 9% by weight.

20. A method of preparing an exploding target for a shooting exercise comprising:

providing a first hard-walled container and a second container comprising:
 the first hard-walled container defining a target of the shooting exercise and comprising:
 a plurality of upstanding container walls defining an outer container periphery;
 a container base at a bottom of the walls;
 a container neck at a top of the walls delimiting a container opening; and
 a container cap removably attached on the neck across the opening;
 a first oxidizing component contained in the hard-walled container;
 a second sensitizing component contained in the second container;
 the first oxidizing component and the second sensitizing component being combinable to form an explosive mixture storable in the hard-walled container;
 transferring the sensitizing component into the hard-walled container to form an aggregate of the oxidizing and sensitizing components;
 mixing the oxidizing and sensitizing components in the hard-walled container so as to form the explosive mixture.

21. The process according to claim **20** wherein the second container comprises a flexible bag disposed in the hard-walled container.

22. The process according to claim **20** wherein the hard-walled container is sized to provide a sufficing air gap between the aggregate of the oxidizing and sensitizing components received therein prior to mixing and the opening of the hard-walled container such that the hard-walled container is adapted for the step of mixing the oxidizing and sensitizing components directly in the container.

23. The process according to claim **22** wherein the sufficing air gap comprises a gap measured in a direction from the container base towards the opening generally between

the aggregate and one of the container base and the opening, and the gap comprises a prescribed range between 5 millimetres and 30 millimetres.

24. The process according to claim 23 wherein the prescribed range comprises an optimal range between 8 millimetres and 26 millimetres.

25. An exploding target for a shooting exercise comprising:

a first hard-walled container defining a target of the shooting exercise, the first hard-walled container comprising:

a plurality of upstanding container walls defining an outer container periphery;

a container base at a bottom of the walls;

a container neck at a top of the walls delimiting a container opening; and

a container cap removably attached on the neck across the opening;

a first oxidizing component contained in the hard-walled container;

a second container containing a second sensitizing component therein;

the first oxidizing component and the second sensitizing component being combinable to form an explosive mixture storable in the hard-walled container;

wherein the second container comprises a flexible bag disposed in the hard-walled container.

26. The exploding target according to claim 25 wherein the flexible bag is sized for passing through the opening of the hard-walled container.

* * * * *