



US 20180175623A1

(19) **United States**

(12) **Patent Application Publication**
Cheng et al.

(10) **Pub. No.: US 2018/0175623 A1**

(43) **Pub. Date: Jun. 21, 2018**

(54) **SMART AND ON/OFF-GRID POWER INVERTERS**

Publication Classification

(51) **Int. Cl.**
H02J 3/38 (2006.01)
(52) **U.S. Cl.**
CPC **H02J 3/38** (2013.01); **Y02E 10/763**
(2013.01); **H02J 3/386** (2013.01); **H02J 3/382**
(2013.01); **H02J 3/383** (2013.01); **Y02E**
10/563 (2013.01)

(71) Applicant: **CyboEnergy, Inc.**, Rancho Cordova, CA (US)
(72) Inventors: **George Shu-Xing Cheng**, Folsom, CA (US); **Steven L. Mulkey**, Cameron Park, CA (US); **Andrew J. Chow**, Sacramento, CA (US)

(57) **ABSTRACT**

A method and apparatus is disclosed that can intelligently invert DC power from single or multiple DC sources to single-phase, split-phase, or three-phase AC power, supply the AC power to the electric power grid when the grid is on, or supply AC power to electric devices or loads when the grid is down. A Smart and Grid-Flexible Power Inverter, or On/Off-Grid Power Inverter, is disclosed that can work in either the on-grid or off-grid mode, and switch back and forth between the two modes manually or automatically depending on the power grid conditions. The system provides a simple and cost-effective solution for areas where the power grid has frequent outages or long downtimes.

(21) Appl. No.: **15/898,091**

(22) Filed: **Feb. 15, 2018**

Related U.S. Application Data

(63) Continuation of application No. 14/630,502, filed on Feb. 24, 2015, now Pat. No. 9,899,841.
(60) Provisional application No. 62/087,644, filed on Dec. 4, 2014.

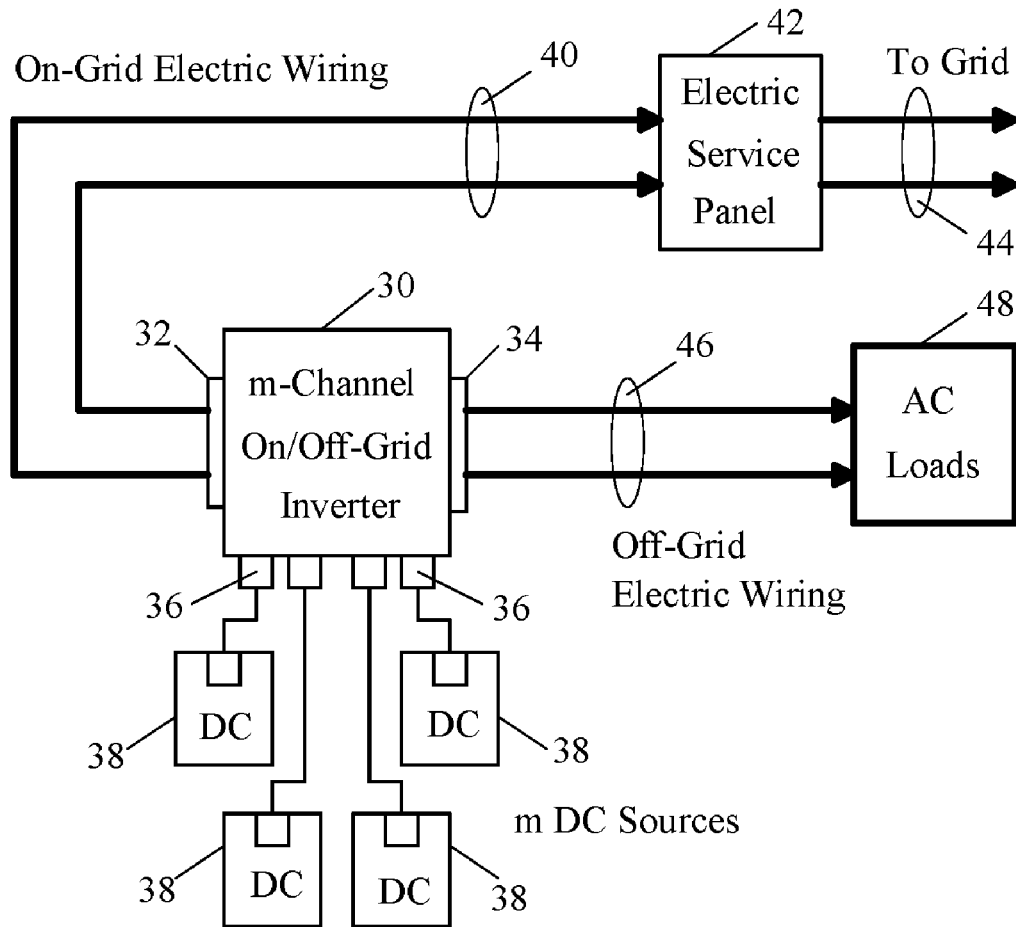

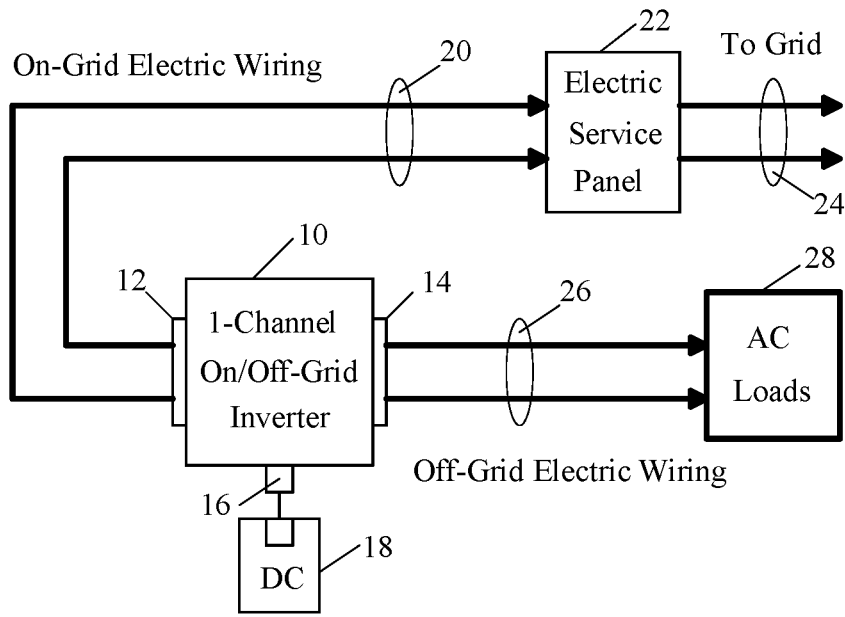

Fig. 1

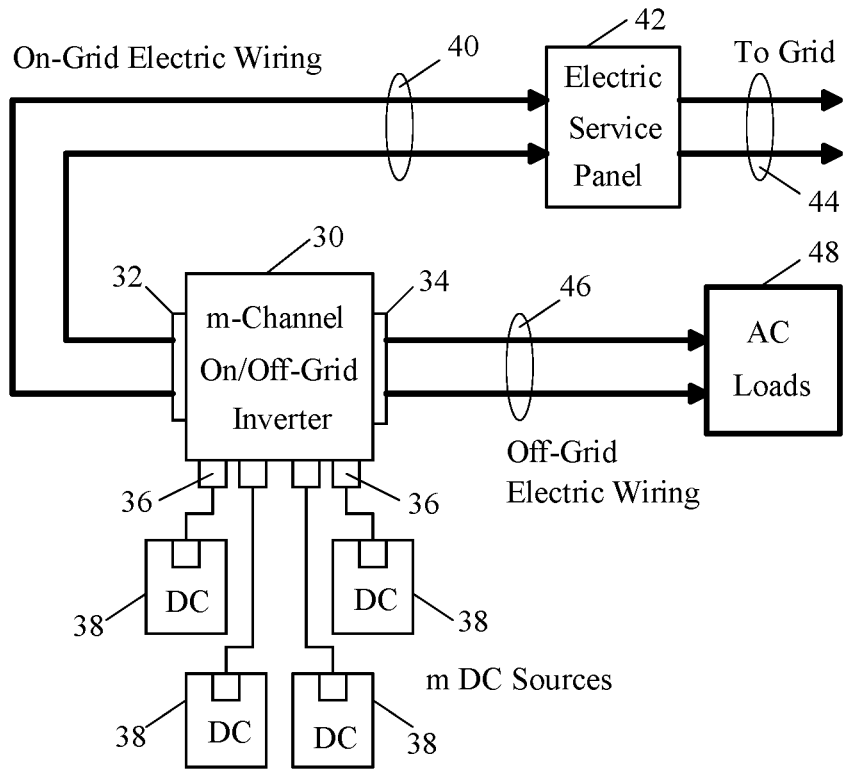

Fig. 2

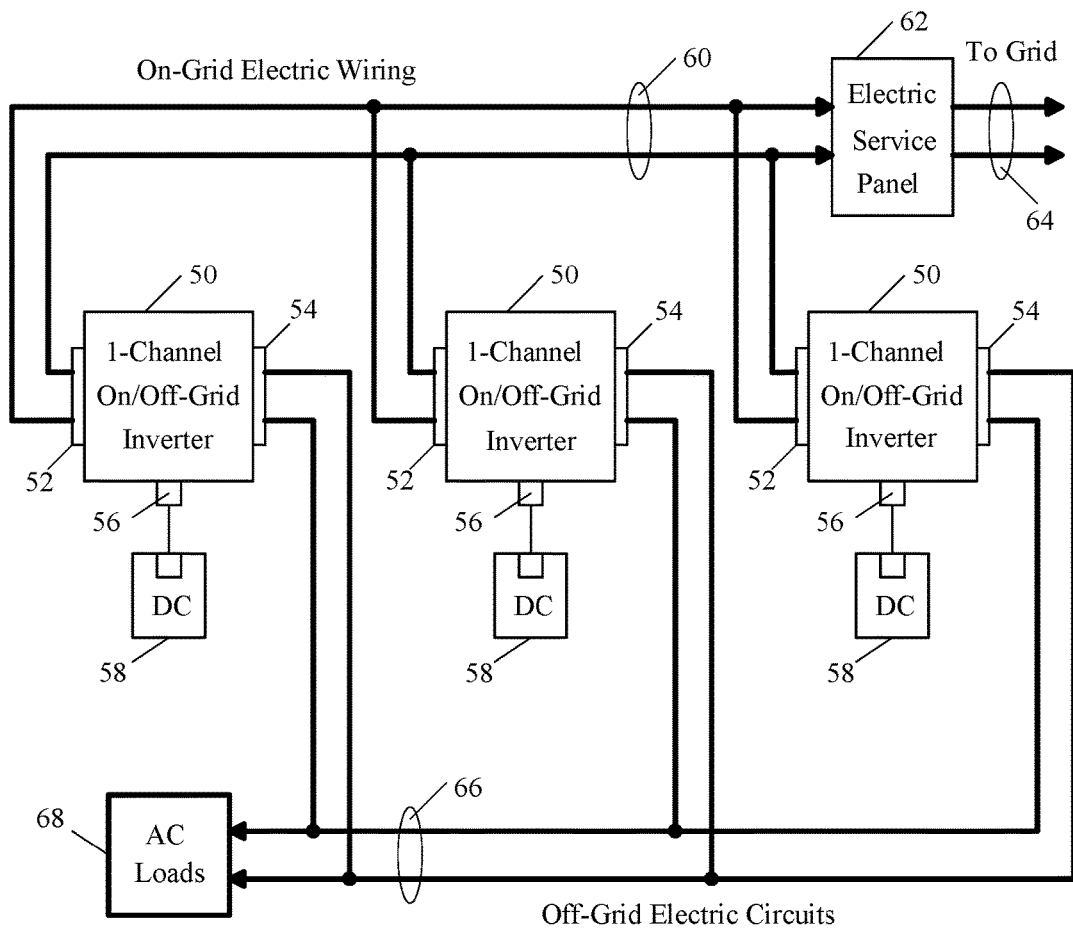

Fig. 3

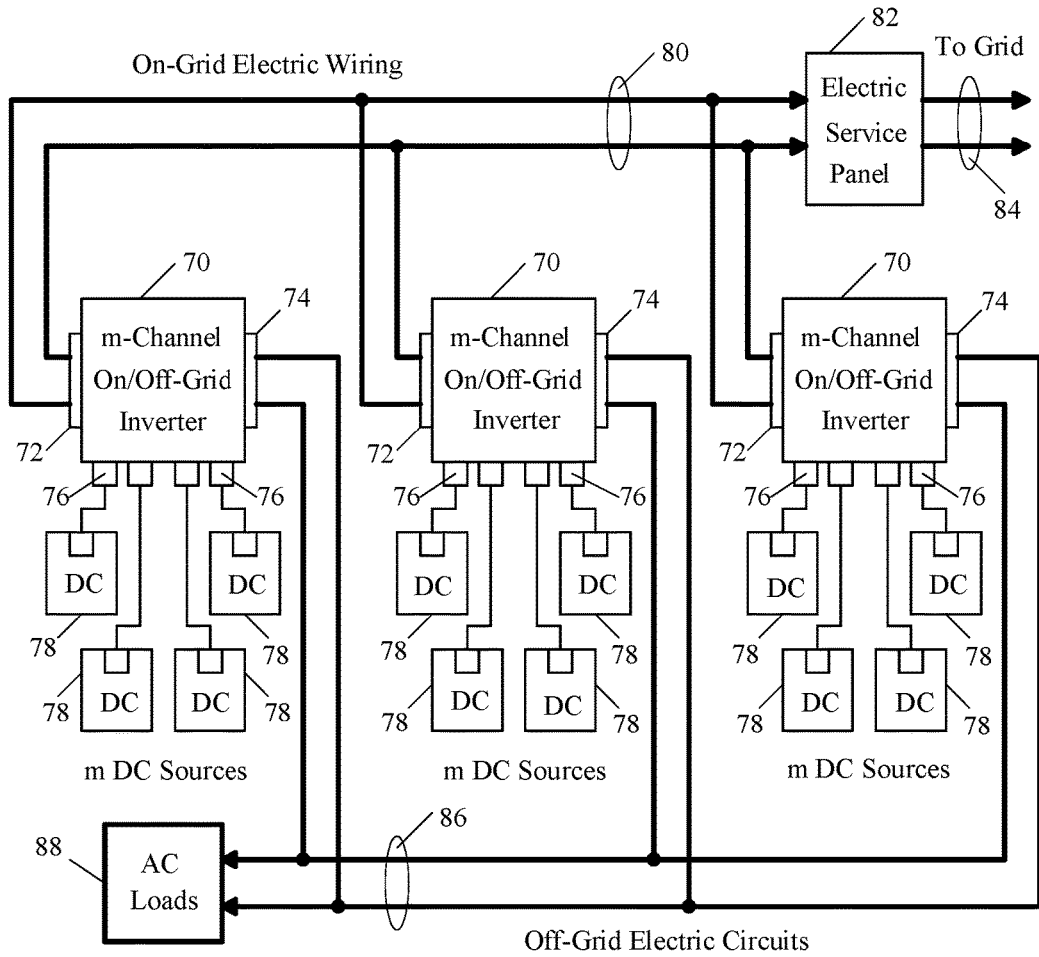

Fig. 4

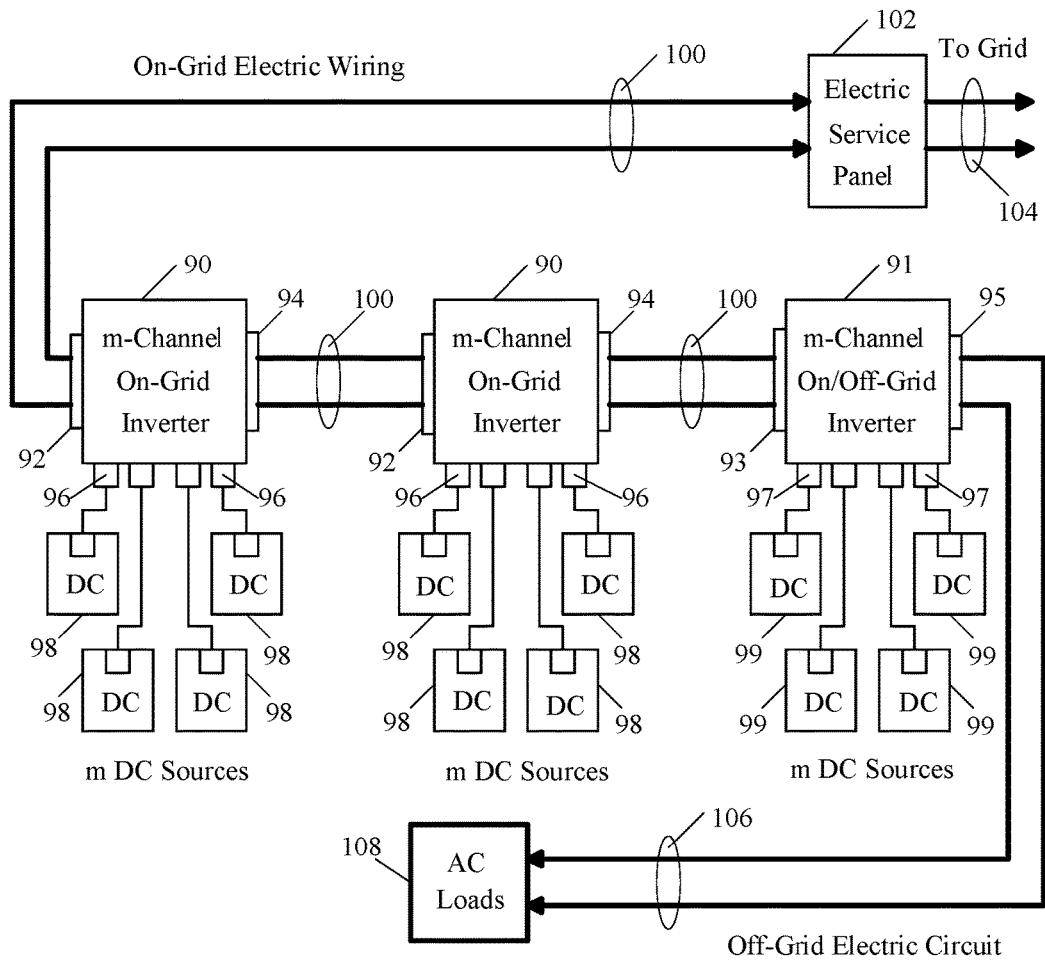

Fig. 5

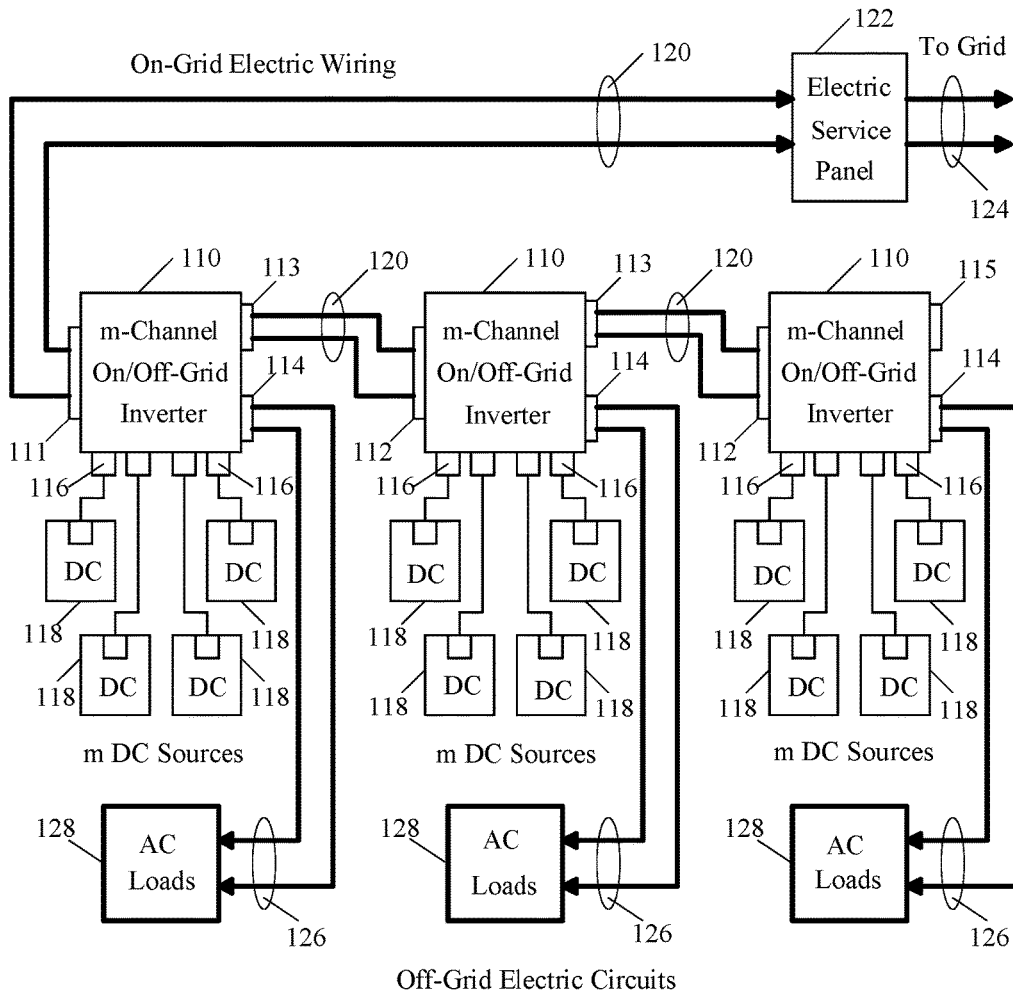

Fig. 6

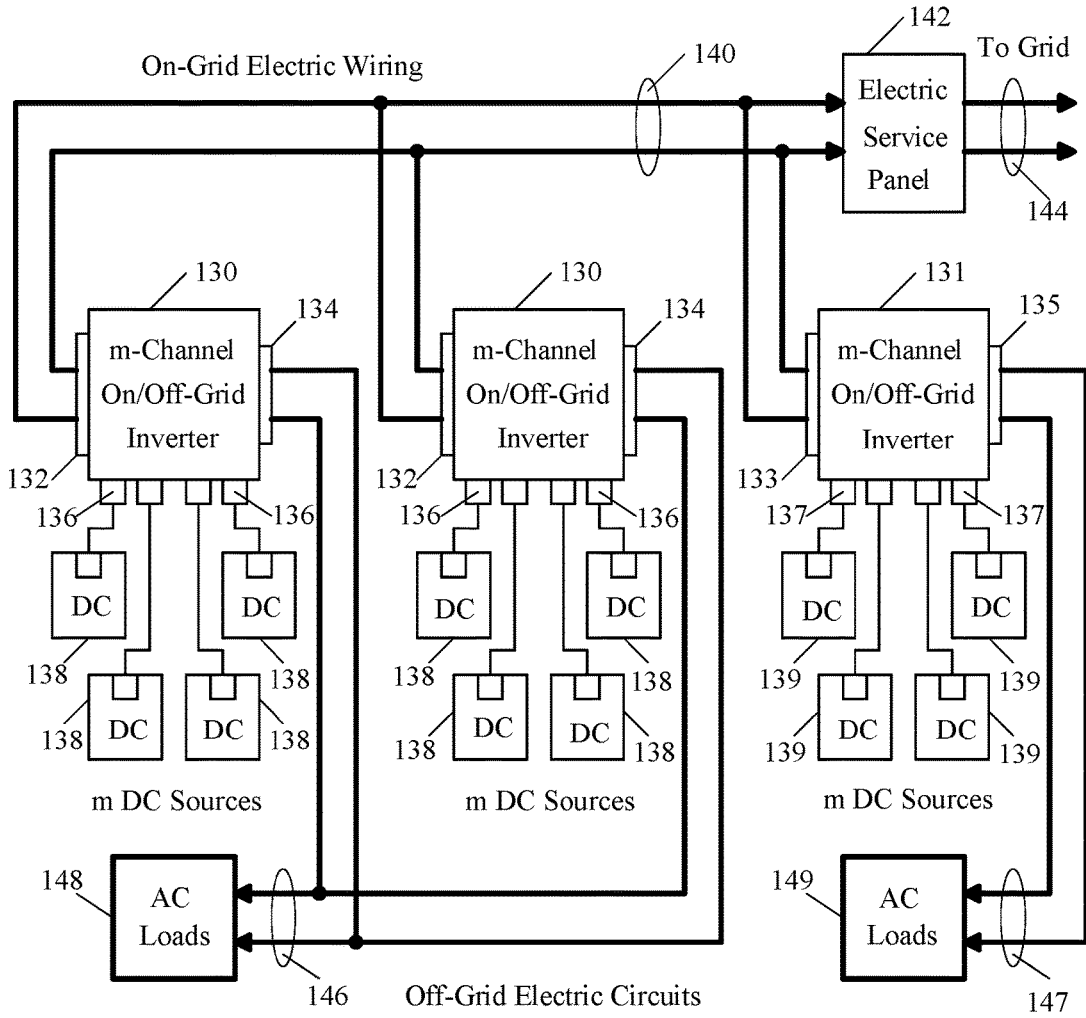

Fig. 7

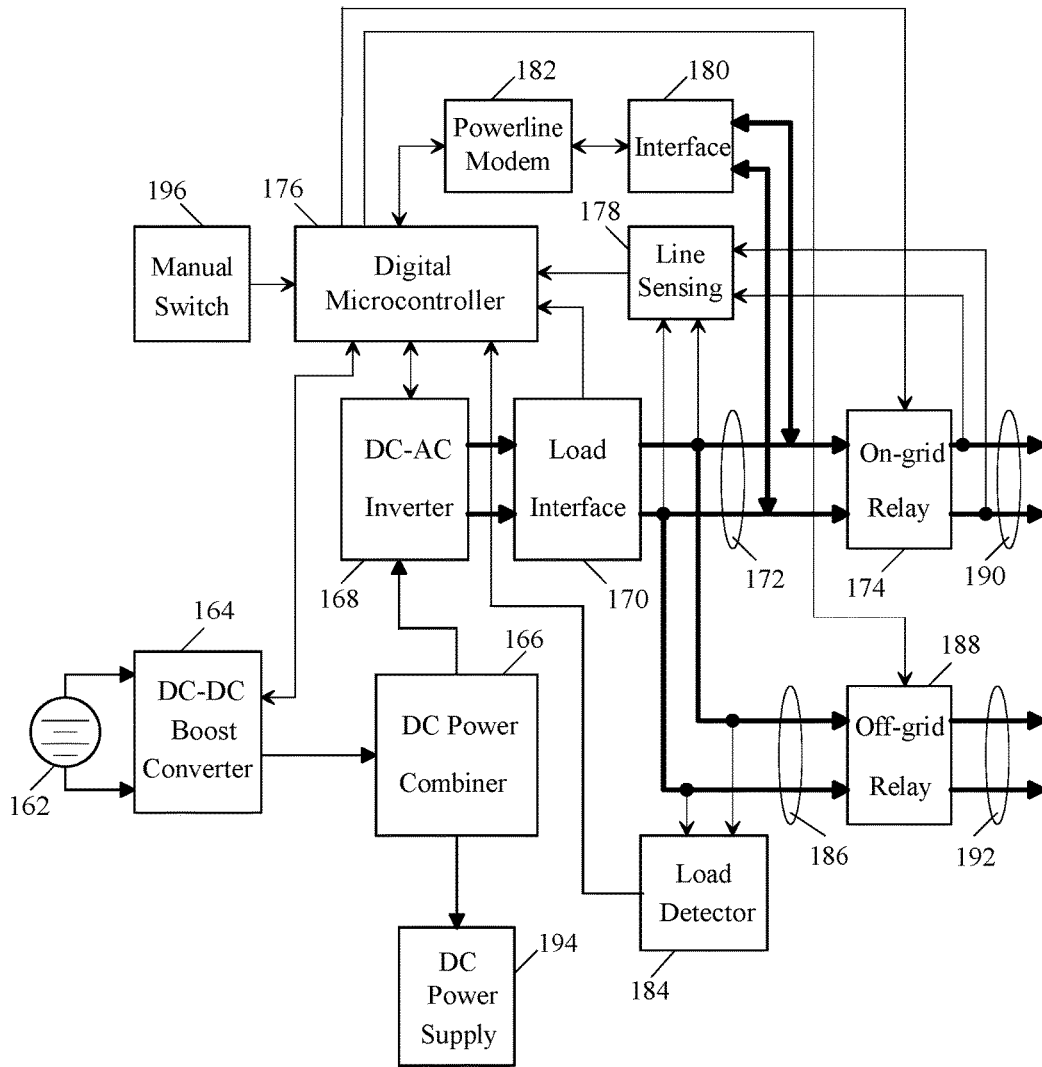

Fig. 8

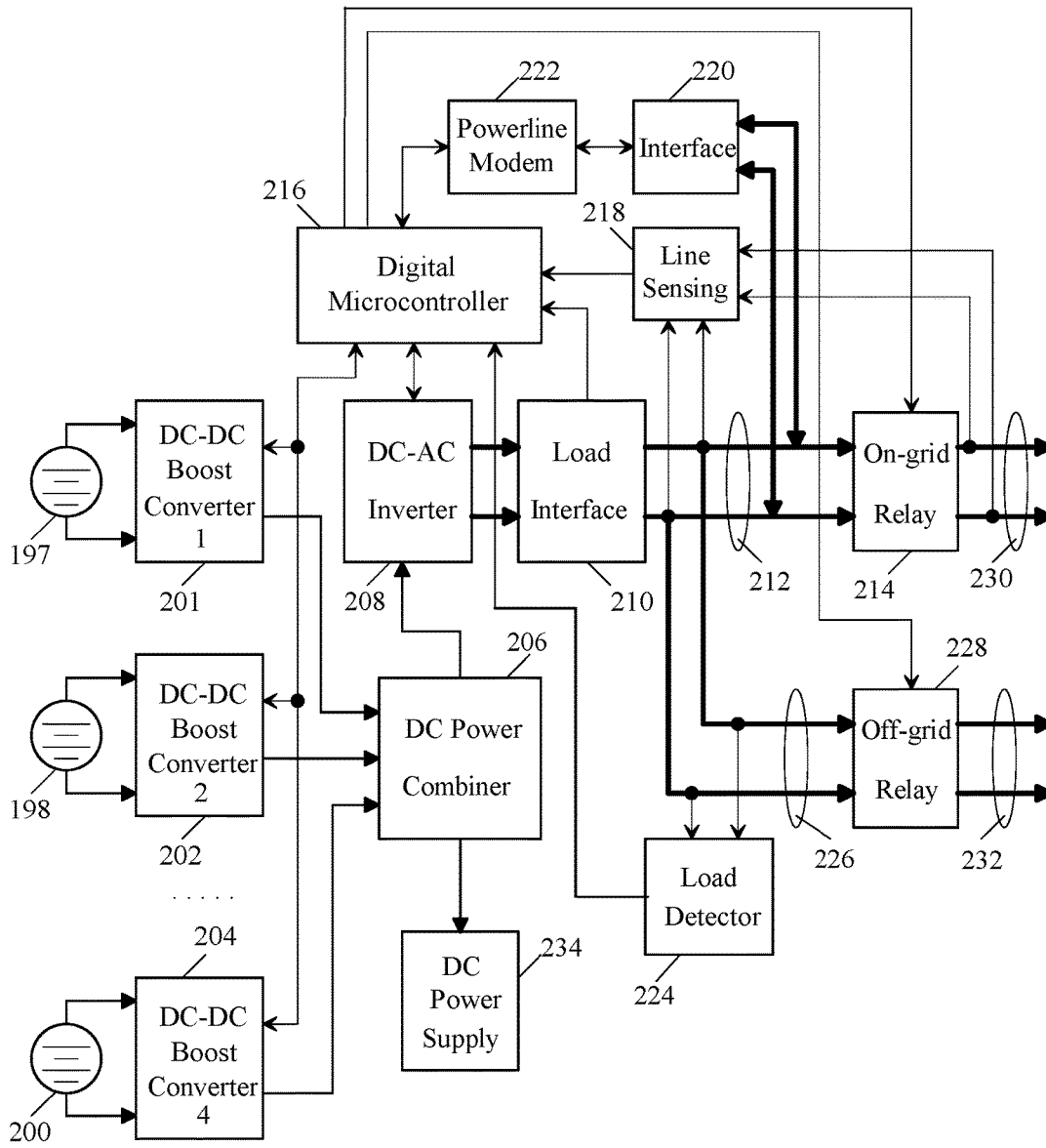

Fig. 9

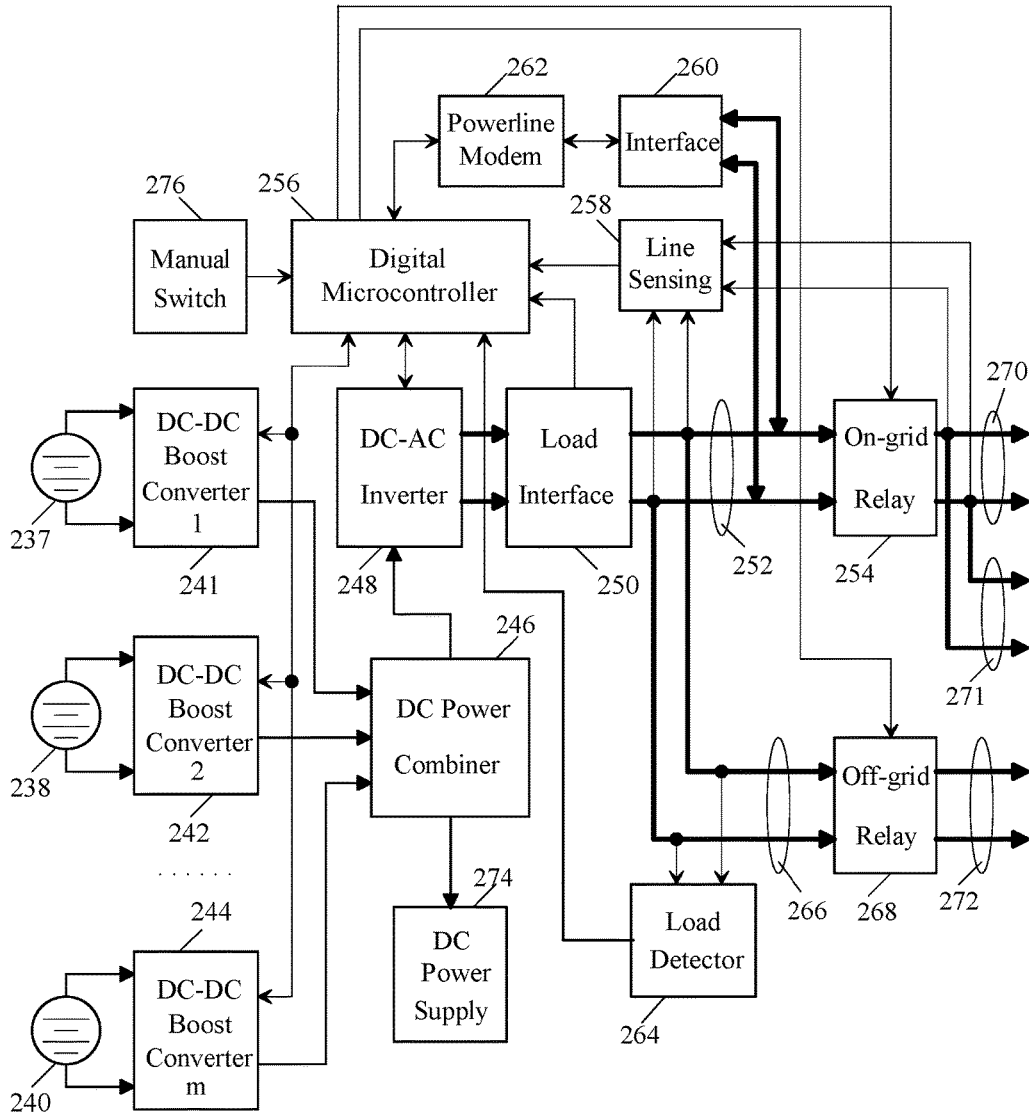

Fig. 10

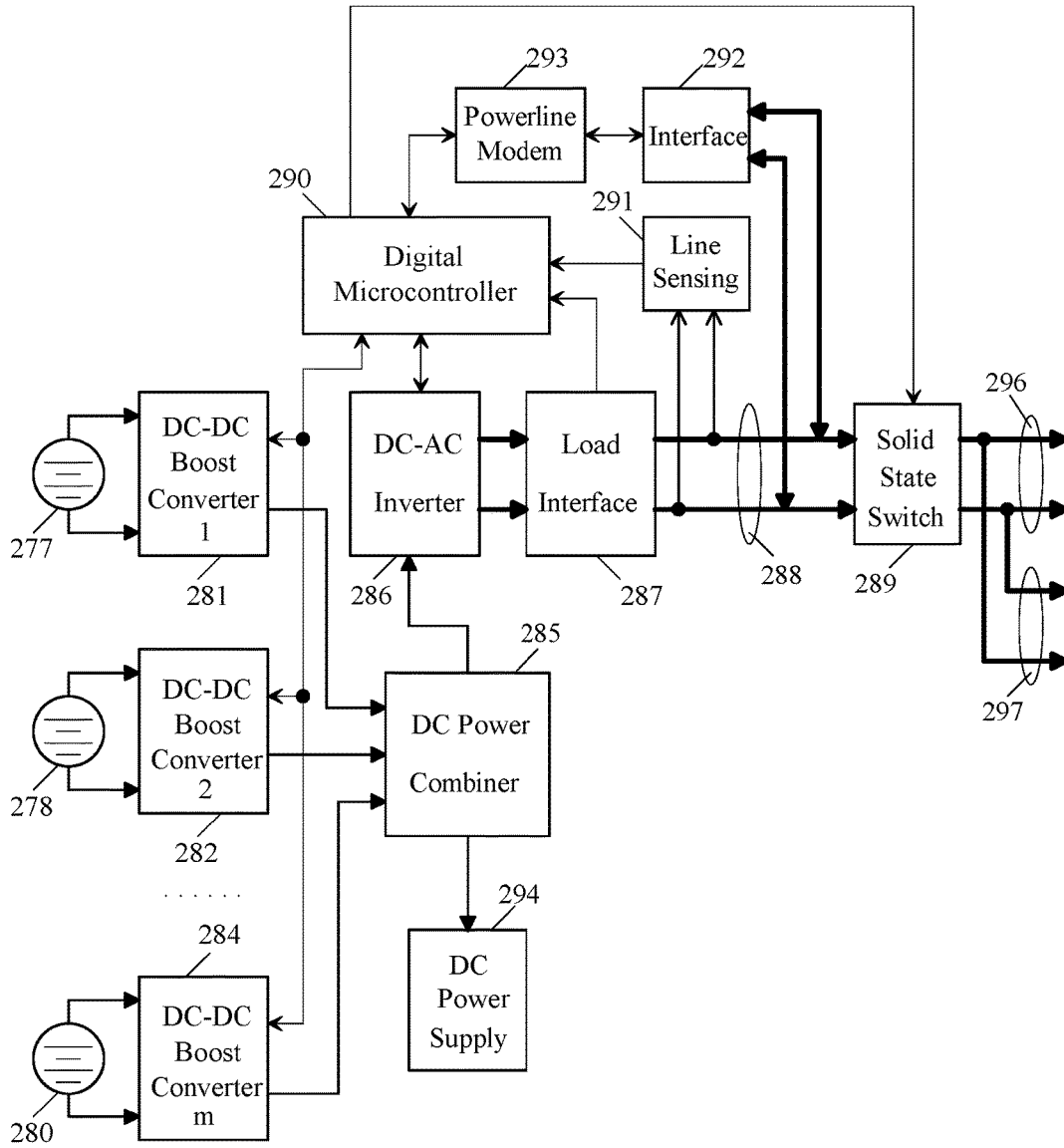

Fig. 11

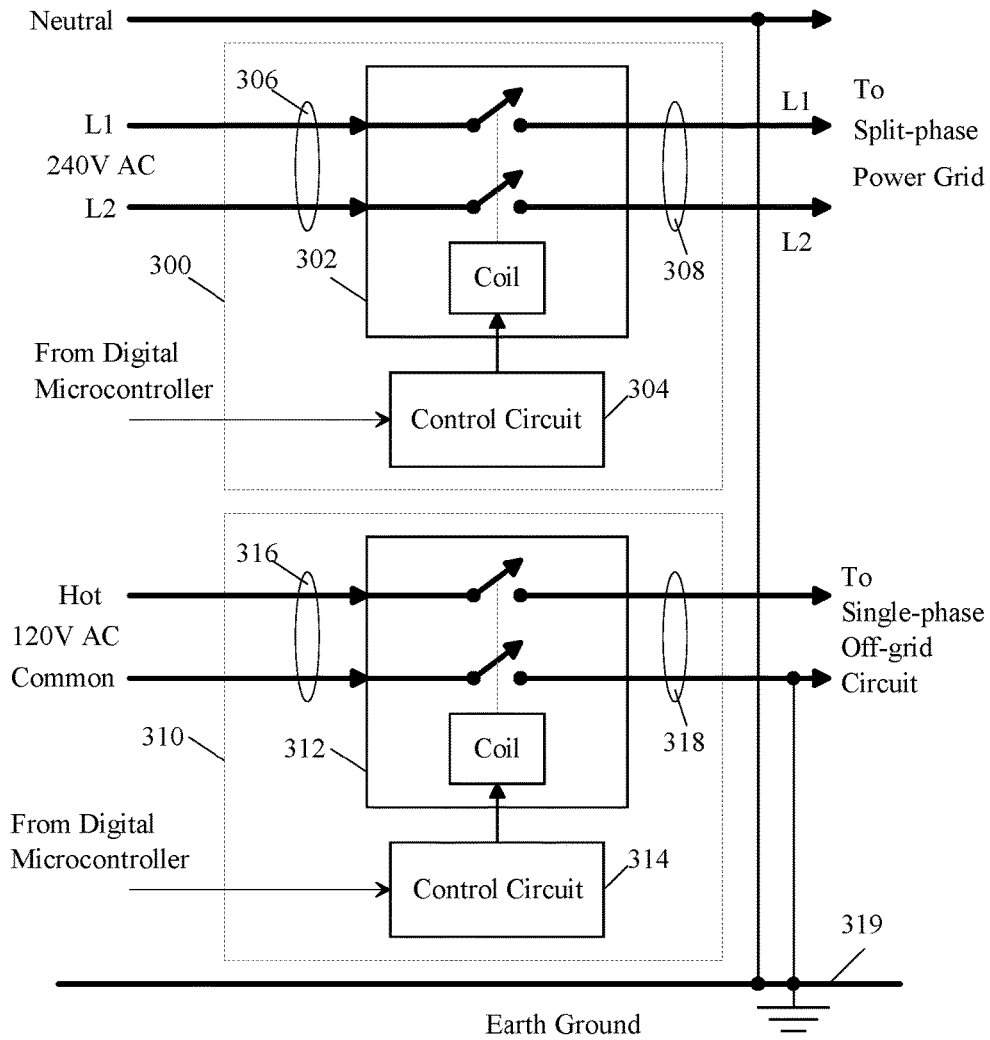

Fig. 12

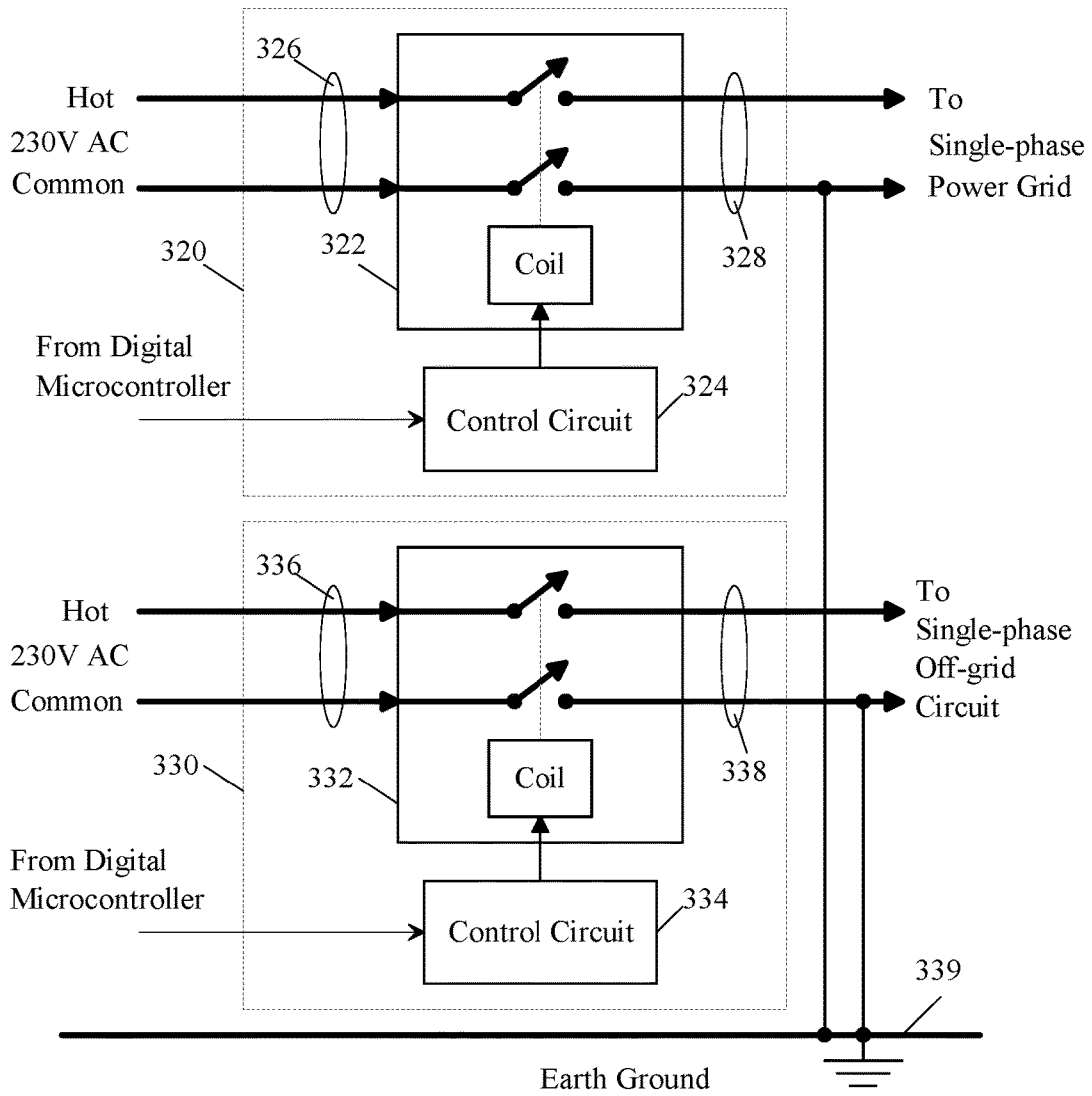

Fig. 13

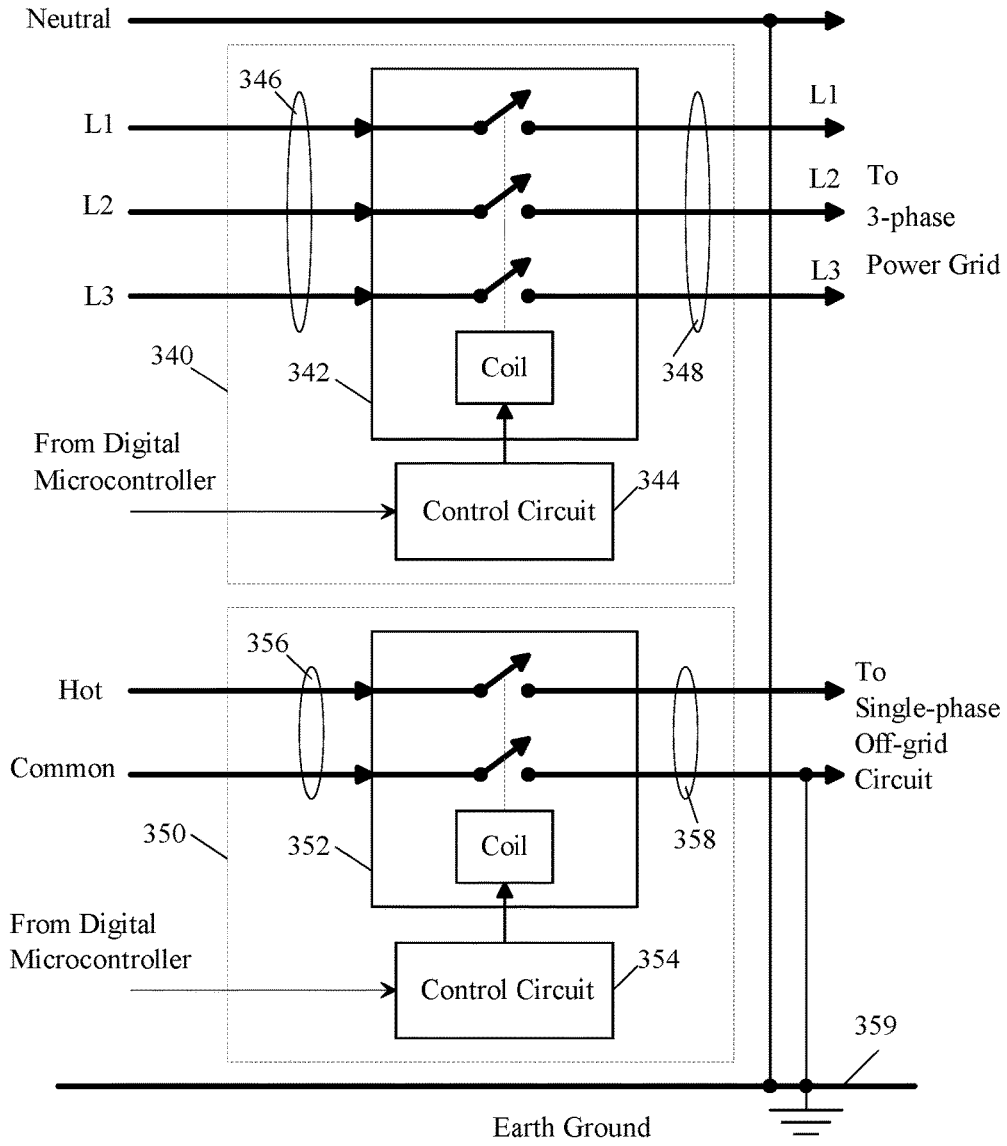

Fig. 14

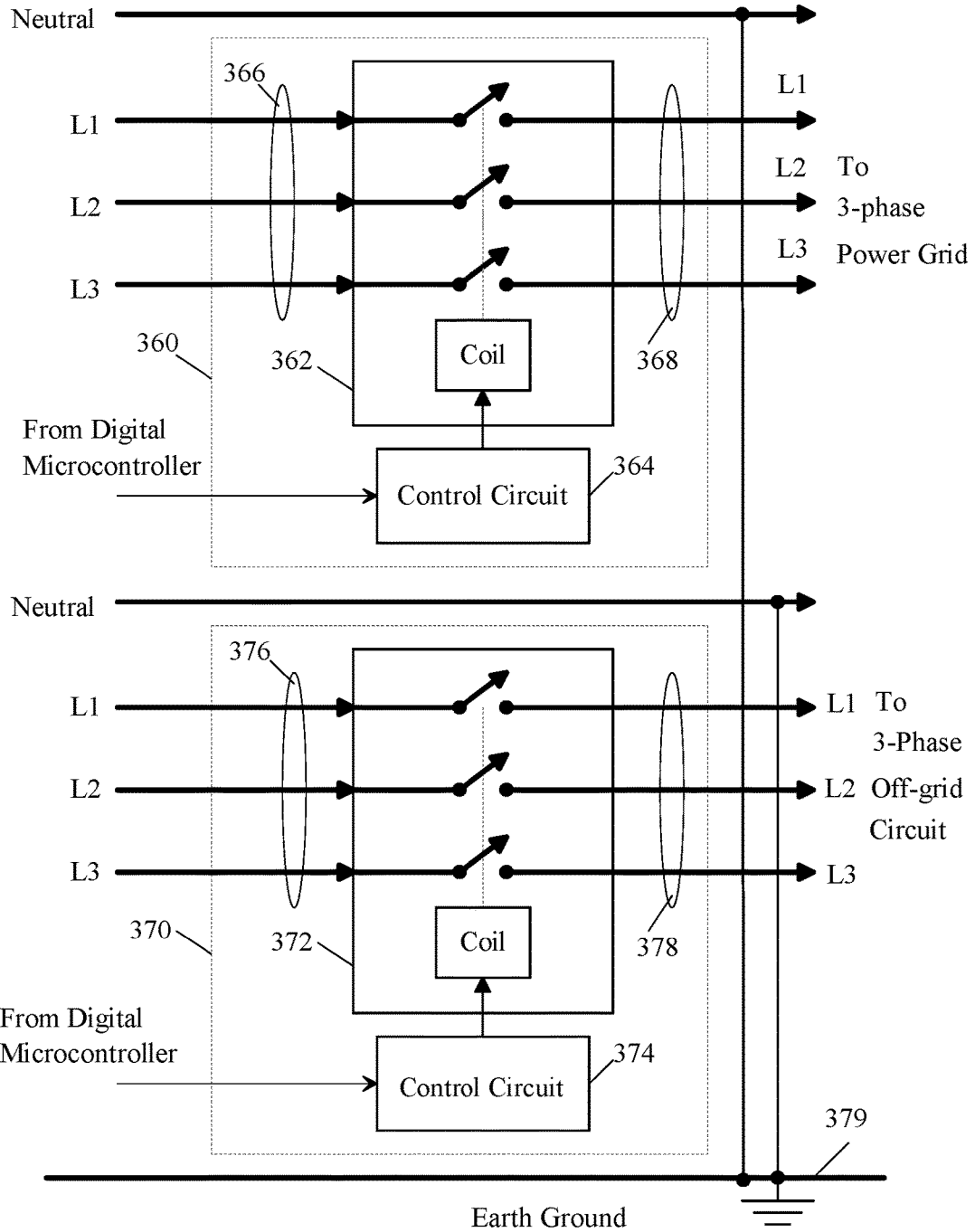

Fig. 15

SMART AND ON/OFF-GRID POWER INVERTERS

BACKGROUND OF THE INVENTION

[0001] This application is a continuation application under 35 U.S.C. 120 of commonly assigned U.S. patent application Ser. No. 14/630,502, entitled Smart and Grid-Flexible Power Inverters and filed on Feb. 24, 2015, which in turn claims the benefit under 35 U.S.C. 119 of commonly assigned U.S. Provisional Application Ser. No. 62/087,644, filed on Dec. 4, 2014. Both of these prior applications are herein expressly incorporated by reference, in their entirety.

[0002] The subject of this patent relates to direct current (DC) to alternating current (AC) power inverters that invert DC power from single or multiple DC power sources to single-phase or three-phase AC power, where the DC power sources include but are not limited to photovoltaic (PV) solar modules or panels, PV cells, PV materials, PV thin films, fuel cells, batteries, wind turbines, bio-fuel generators, and other DC power generators. More particularly, this patent relates to a method and apparatus that can intelligently invert DC power from single or multiple DC sources to AC power, supply the AC power to the electric power grid when the grid is on, or supply AC power to electrical devices or loads when the grid is down. This approach provides a simple and cost-effective solution for areas where the power grid has frequent outages or long downtimes.

[0003] In the U.S. Pat. No. 8,786,133, the entirety of which is hereby incorporated by reference, we described the novel Smart and Scalable Power Inverters and the unique scalable design so that the DC to AC power inversion system can include as few as one inverter and one DC source, up to a selected number of inverters and multiple DC sources. A number of smart single-input, dual-input, triple-input, quad-input, and multiple-input power inverters in a mixed variety can easily connect to single, dual, triple, quad, and multiple DC power sources, invert the DC power to AC power, and daisy chain together to generate a total power, which is equal to the summation of the AC power supplied by each smart and scalable power inverter.

[0004] In the U.S. patent application Ser. No. 13/397,402, the entirety of which is hereby incorporated by reference, we described the Scalable and Redundant Mini-Inverters that have double, triple, or quadruple redundant capabilities so that the Mini-Inverters can work in a harsh environment for a prolonged period of time. A number of regular, redundant, triple redundant, or quadruple redundant Mini-Inverters with one, two, three, or multiple input channels in a mixed variety can easily connect to one, two, three, or multiple DC power sources such as solar PV modules, invert the DC power to AC power, and daisy chain together to generate AC power to feed the power grid.

[0005] In the U.S. patent application Ser. No. 13/493,622, the entirety of which is hereby incorporated by reference, we described the Smart and Scalable Off-Grid Mini-Inverters having one or multiple DC input channels that can invert DC power to AC power, and supply AC power to power electrical devices including motors, pumps, fans, lights, appliances, and homes.

[0006] In the U.S. patent application Ser. No. 13/537,206, the entirety of which is hereby incorporated by reference, we described an enclosure design to accommodate and support the unique features and capabilities of the Smart and Scalable Power Mini-Inverters that have multiple input channels,

and a messaging system using LEDs (light-emitting diodes) mounted on the enclosure to indicate the system status of the Smart and Scalable Mini-Inverters.

[0007] In the U.S. patent application Ser. No. 13/789,637, the entirety of which is hereby incorporated by reference, we described a method and apparatus for maximizing power production for solar power systems when there is low sunlight during sunrise, sunset, clouding, partial shading, and other low irradiance conditions. A multiple-channel solar power Mini-Inverter can work in the low power mode when there is low sunlight, take power from one solar module to supply DC power to its internal electronic circuits, and also invert the DC power from the remaining connected solar modules to AC power feeding to the electric grid or powering AC loads.

[0008] In the U.S. patent application Ser. No. 13,844/484, the entirety of which is hereby incorporated by reference, we described a method and apparatus that can monitor the solar power inverters in real-time both day and night, and generate surveillance alarms and actions when a solar power inverter is removed or disconnected from the AC powerline for no good reason. It offers a low cost and reliable surveillance means to help guard a residential-scale, commercial-scale, or utility-scale solar power system in real-time at all times.

[0009] In the U.S. patent application Ser. No. 13/846,708, the entirety of which is hereby incorporated by reference, we described a method and apparatus for solar power generation when irradiance changes quickly or is very low due to sunrise, sunset, clouding, partial shading, warped PV surfaces, moving solar modules, and other low or varying irradiance conditions. A multi-channel solar power inverter connected to multiple solar modules can work in a "Lunar Power Mode", inverting DC power induced from the sky, street lights, or surrounding environment to AC power.

[0010] In this patent, we disclose the Smart and Grid-Flexible Power Inverters, or On/Off-Grid Power Inverters, that can work in either the on-grid or off-grid mode, and switch back and forth between the two modes automatically or manually depending on the power grid conditions. Each Smart and Grid-Flexible Power Inverter can have one or multiple DC input channels that can connect to one or multiple DC sources directly. The same inverter may be called either the smart and grid-flexible power inverter or on/off-grid power inverter.

BRIEF DESCRIPTION OF THE DRAWINGS

[0011] FIG. 1 is a block diagram illustrating a grid-flexible power inversion and optimization system where one single-channel on/off-grid power inverter inverts the DC power from one DC source to AC power, and either sends AC power to the electric grid or to an off-grid AC circuit to power AC loads, according to an embodiment of this invention.

[0012] FIG. 2 is a block diagram illustrating a grid-flexible power inversion and optimization system where one m-channel on/off-grid power inverter inverts the DC power from multiple DC sources to AC power, and either sends AC power to the electric grid or to an off-grid AC circuit to power AC loads, according to an embodiment of this invention.

[0013] FIG. 3 is a block diagram illustrating a grid-flexible power inversion and optimization system where 2 or more single-channel on/off-grid power inverters are arranged as a group, each of the inverters inverts the DC power from one

DC source to AC power, where the combined AC power from all inverters is either sent to the electric grid or to an off-grid AC circuit to power AC loads, according to an embodiment of this invention.

[0014] FIG. 4 is a block diagram illustrating a grid-flexible power inversion and optimization system where 2 or more m-channel on/off-grid power inverters are arranged as a group, each of the inverters inverts the DC power from m DC sources to AC power, where the combined AC power from all inverters is either sent to the electric grid or to an off-grid AC circuit to power AC loads, according to an embodiment of this invention.

[0015] FIG. 5 is a block diagram illustrating a combined on-grid and grid-flexible power inversion and optimization system where 2 or more m-channel on-grid power inverters and one m-channel on/off-grid power inverter daisy-chain to form a group, each of the inverters inverts the DC power from m DC sources to AC power, where the combined AC power from the on-grid outputs of all inverters is sent to the electric grid when the grid is on, and when the grid is down, AC power from the off-grid output of the on/off-grid power inverter is sent to an off-grid AC circuit to power AC loads, according to an embodiment of this invention.

[0016] FIG. 6 is a block diagram illustrating a grid-flexible power inversion and optimization system where 2 or more m-channel on/off-grid power inverters daisy-chain to form a group, each of the inverters inverts the DC power from m DC sources to AC power, where the combined AC power from the on-grid outputs of all inverters is sent to the electric grid when the grid is on, and when the grid is down, AC power from the off-grid output of each of the inverters powers its corresponding connected AC loads, according to an embodiment of this invention.

[0017] FIG. 7 is a block diagram illustrating a grid-flexible power inversion and optimization system where 2 or more m-channel on/off-grid power inverters are arranged as a group, each of the inverters inverts the DC power from m DC sources to AC power, where the combined AC power from the on-grid outputs of all inverters is sent to the electric grid when the grid is on, and when the grid is down, single or multiple off-grid outputs from their corresponding inverters are combined to form 2 or more off-grid circuits to power the connected AC loads, respectively, according to an embodiment of this invention.

[0018] FIG. 8 is a block diagram illustrating a smart single-channel on/off-grid power inverter that inverts the DC power from one DC source to AC power and supplies the AC power either through its on-grid AC output port or off-grid AC output port, according to an embodiment of this invention.

[0019] FIG. 9 is a block diagram illustrating a smart 4-channel on/off-grid power inverter that inverts the DC power from four DC sources to AC power and supplies the AC power either through its on-grid AC output port or off-grid AC output port, according to an embodiment of this invention.

[0020] FIG. 10 is a block diagram illustrating a smart m-channel on/off-grid power inverter that inverts the DC power from m DC sources to AC power and supplies the AC power either through its on-grid AC output port or off-grid AC output port, according to an embodiment of this invention.

[0021] FIG. 11 is a block diagram illustrating a smart m-channel on-grid power inverter that inverts the DC power

from m DC sources to AC power to be sent to the electric grid, where the inverter's external AC powerline shows 2 pairs of AC wires.

[0022] FIG. 12 is a block diagram illustrating an on/off-grid power inverter's on-grid AC output port to supply AC power to an electric grid with split-phase AC, and inverter's off-grid AC output port to supply AC power to single-phase AC loads, according to an embodiment of this invention.

[0023] FIG. 13 is a block diagram illustrating an on/off-grid power inverter's on-grid AC output port to supply AC power to a single-phase AC power grid, and inverter's off-grid AC output port to supply AC power to single-phase AC loads, according to an embodiment of this invention.

[0024] FIG. 14 is a block diagram illustrating an on/off-grid power inverter's on-grid AC output port to supply AC power to a three-phase AC power grid, and inverter's off-grid AC output port to supply AC power to single-phase AC loads, according to an embodiment of this invention.

[0025] FIG. 15 is a block diagram illustrating an on/off-grid power inverter's on-grid AC output port to supply AC power to a three-phase AC power grid, and inverter's off-grid AC output port to supply AC power to three-phase AC loads, according to an embodiment of this invention.

[0026] The term "mechanism" is used herein to represent hardware, software, or any combination thereof. The term "solar panel" or "solar module" refers to photovoltaic (PV) solar modules. The term "AC load" is used herein to represent one or more single-phase or three-phase electrical devices including but not limited to motors, pumps, fans, lights, appliances, and homes.

[0027] Throughout this document, $m=1, 2, 3, \dots$, as an integer, which is used to indicate the number of the DC input ports of an inverter. The term "input channel" refers to the DC input port of the inverter. Then, an m-channel inverter means that the inverter has m input channels or m DC input ports. The term "m-channel inverter" refers to an inverter that has m input channels, where $m=1, 2, 3, \dots$, as an integer.

[0028] Throughout this document, a DC source can be in any one of the following forms including a solar panel or a set of solar panels combined in series and/or parallel, a battery or a set of batteries combined in series and/or parallel, a fuel cell or a set of fuel cells combined in series and/or parallel, a wind generator, and other types of DC power generators.

[0029] Throughout this document, if a power inverter is used to generate single-phase AC, it can also be applied to three-phase AC without departing from the spirit or scope of our invention. If a solar inverter is used to generate three-phase AC, it can also be applied to single-phase AC without departing from the spirit or scope of our invention. The AC power and related electric grid and AC load can be either single-phase, split-phase, or three-phase.

[0030] Without losing generality, all numerical values given in this patent are examples. Other values can be used without departing from the spirit or scope of our invention. The description of specific embodiments herein is for demonstration purposes and in no way limits the scope of this disclosure to exclude other not specially described embodiments of this invention.

DETAILED DESCRIPTION OF THE
INVENTION

[0031] While this patent is being written, the world is experiencing climate changes that are impacting our lives. Changes in temperature, precipitation, and sea level have caused more frequent and severe hurricanes in summer and snowstorms in winter shutting down power grids for hours and even weeks. Since the infrastructure of our society is built upon electricity, losing grid power causes significant disruption and hardship to the lives to which we have become accustomed.

[0032] Power backup systems are used to power key electrical devices and appliances. Traditionally, diesel generators are used for such power backup systems. They work reasonably well but are noisy, costly to run, and cause air pollution. Solar power backup systems are getting more popular because they offer a green energy solution with no noise. However, one major shortcoming of a solar power backup system is that the solar power is wasted when the grid is on. This is because the off-grid power inverters used in backup systems are designed to power AC loads, which cannot send power to the grid. On the other hand, on-grid solar inverters are required to shutdown within a fraction of a second when the grid is down to keep the grid safe. These on-grid inverters are designed to deliver power to the grid and cannot power AC loads, and therefore cannot be used for solar power backup systems.

[0033] In this patent, smart and grid-flexible power inverters are disclosed that can work in either the on-grid or off-grid mode, and switch back and forth between the two modes automatically depending on the power grid conditions. This means that the same solar power system can generate solar power to the grid and can also be a power backup system when the grid is down. The solar power systems enabled by the smart and grid-flexible power inverters can be a useful and cost-effective solution for areas where frequent power outages and long downtimes are common.

[0034] FIG. 1 is a block diagram illustrating a grid-flexible power inversion and optimization system where one single-channel on/off-grid power inverter inverts the DC power from one DC source to AC power, and either sends AC power to the electric grid or to an off-grid AC circuit to power AC loads, according to an embodiment of this invention.

[0035] The system comprises a single-channel on/off-grid power inverter 10, a DC power source such as a solar panel 18, an inverter's on-grid AC power output port 12, an inverter's off-grid AC power output port 14, an inverter's DC input channel 16, an on-grid AC powerline 20, a power service panel 22, a power grid 24, an off-grid AC powerline 26, and AC loads 28. The power inverter 10 connects to the DC power source 18 through its DC input channel 16. This is a simple case of a grid-flexible DC to AC power inversion and optimization system, where the on/off-grid power inverter takes DC power from the DC power source, inverts the DC power to AC power, outputs the AC power to the power grid 24 via the AC powerline 20 and the power service panel 22 while the grid is on, or outputs the AC power to power the AC loads 28 via the AC powerline 26 while the grid is down.

[0036] The DC source for the power inverter can be in any one of the following forms including a solar panel or a set of solar panels combined in series and/or parallel, a battery

or a set of batteries combined in series and/or parallel, a fuel cell or a set of fuel cells combined in series and/or parallel, and a wind generator. The AC power and related electric grid and AC load in this embodiment and in the embodiments to be described in FIGS. 2 to 7 can be single-phase, split-phase, or 3-phase. The 2 AC wires in the drawing are there to show the concept and method.

[0037] FIG. 2 is a block diagram illustrating a grid-flexible power inversion and optimization system where one m-channel on/off-grid power inverter inverts the DC power from multiple DC sources to AC power, and either sends AC power to the electric grid or to an off-grid AC circuit to power AC loads, according to an embodiment of this invention.

[0038] The system comprises a m-channel on/off-grid power inverter 30, m DC power sources such as solar panels 38, an inverter's on-grid AC power output port 32, an inverter's off-grid AC power output port 34, inverter's multiple DC input channels 36, an on-grid AC powerline 40, a power service panel 42, a power grid 44, an off-grid AC powerline 46, and AC loads 48. The power inverter 30 connects to the DC power sources 38 through its DC input channels 36, respectively. In this grid-flexible DC to AC power inversion and optimization system, the on/off-grid power inverter takes DC power from multiple DC power sources, inverts the DC power to AC power, outputs the AC power to the power grid 44 via the AC powerline 40 and the power service panel 42 while the grid is on, or outputs the AC power to power the AC loads 48 via the AC powerline 46 while the grid is down.

[0039] FIG. 3 is a block diagram illustrating a grid-flexible power inversion and optimization system where 2 or more single-channel on/off-grid power inverters are arranged as a group, each of the inverters inverts the DC power from one DC source to AC power, where the combined AC power from all inverters is either sent to the electric grid or to an off-grid AC circuit to power AC loads, according to an embodiment of this invention.

[0040] The system comprises 2 or more single-channel on/off-grid power inverters 50, each of which has one DC power input channel 56 that is connected to a corresponding DC power source 58, respectively. Each power inverter 50 comprises an on-grid AC power output port 52 and an off-grid AC power output port 54. The on-grid AC outputs from all power inverters are combined in parallel with an on-grid AC powerline 60, and the off-grid AC outputs from all power inverters are combined in parallel with an off-grid AC powerline 66. The system also comprises a power service panel 62, a power grid 64, and AC loads 68.

[0041] In this system, each on/off-grid power inverter takes DC power from its corresponding DC power source, inverts the DC power to AC power, and outputs the AC power through either the on-grid AC output port or off-grid AC output port depending on the grid condition. When the grid is on, the combined AC power from all inverters is sent to the power grid 64 via the AC powerline 60 and the power service panel 62. When the grid is down, the combined AC power from all inverters powers the AC loads 68 via the AC powerline 66.

[0042] FIG. 4 is a block diagram illustrating a grid-flexible power inversion and optimization system where 2 or more m-channel on/off-grid power inverters are arranged as a group, each of the inverters inverts the DC power from m DC sources to AC power, where the combined AC power

from all inverters is either sent to the electric grid or to an off-grid AC circuit to power AC loads, according to an embodiment of this invention.

[0043] Without losing generality, the system comprises 2 or more m-channel on/off-grid power inverters **70**, each of which has m DC power input channels **76** that are connected to m corresponding DC power sources **78**, respectively. Each power inverter **70** comprises an on-grid AC power output port **72** and an off-grid AC power output port **74**. The on-grid AC outputs from all power inverters are combined in parallel with an on-grid AC powerline **80**, and the off-grid AC outputs from all power inverters are combined in parallel with an off-grid AC powerline **86**. The system also comprises a power service panel **82**, a power grid **84**, and AC loads **88**.

[0044] In this system, each on/off-grid power inverter takes DC power from its corresponding DC power sources, inverts the DC power to AC power, and outputs the AC power through either the on-grid AC output port or off-grid AC output port depending on the grid condition. When the grid is on, the combined AC power from all inverters is sent to the power grid **84** via the AC powerline **80** and the power service panel **82**. When the grid is down, the combined AC power from all inverters powers the AC loads **88** via the AC powerline **86**.

[0045] In this design, $m=1, 2, 3, \dots$, as an integer, which is used to indicate the number of DC sources and the DC input channels of the inverter. The DC source for each input channel can be in any one of the following forms including a solar panel or a set of solar panels combined in series and/or parallel, a battery or a set of batteries combined in series and/or parallel, a fuel cell or a set of fuel cells combined in series and/or parallel, and a wind generator.

[0046] FIG. 5 is a block diagram illustrating a combined on-grid and grid-flexible power inversion and optimization system where 2 or more m-channel on-grid power inverters and one m-channel on/off-grid power inverter daisy-chain to form a group, each of the inverters inverts the DC power from m DC sources to AC power, where the combined AC power from the on-grid outputs of all inverters is sent to the electric grid when the grid is on, and when the grid is down, AC power from the off-grid output of the on/off-grid power inverter is sent to an off-grid AC circuit to power AC loads, according to an embodiment of this invention.

[0047] Without losing generality, the system comprises 2 or more m-channel on-grid power inverters **90** and one on/off-grid power inverter **91**, each of which has m DC power input channels **96** or **97** that are connected to m corresponding DC power sources **98** or **99**, respectively.

[0048] The m-channel on-grid power inverters are disclosed in U.S. Pat. No. 8,786,133 and subsequent patent applications. Each on-grid power inverter **90** comprises an on-grid AC power output port **92** and an on-grid AC power input port **94**. The on-grid power inverters can daisy chain, where the AC output port of an inverter connects to the AC input port of the next inverter, and so on. The first power inverter's AC input port is left open, and the last power inverter's AC output port is connected to an AC power service panel so that the generated AC power can be sent to the power grid. This method greatly simplifies the wiring job when installing a PV solar power system.

[0049] Although we say the power inverters daisy chain, where the AC output port of each power inverter is connected to the AC input port of the next power inverter, the

actual connection of the inverters is pass-through. That means, the generated AC power from each power inverter is added in parallel onto the AC powerline.

[0050] The on/off-grid power inverter **91** comprises an on-grid AC power output port **93** and an off-grid AC power output port **95**. Its on-grid AC output port **93** can be daisy-chained with the AC input port **94** of the first on-grid power inverter **90**. This way, all the inverters are daisy-chained through the on-grid AC powerline **100**. The off-grid AC output port **95** of the on/off-grid power inverter **91** is connected to an off-grid AC powerline **106** to form an off-grid AC circuit.

[0051] In this combined on-grid and grid-flexible DC to AC power inversion and optimization system, each power inverter takes DC power from its corresponding DC power sources, inverts the DC power to AC power. When the grid is on, the combined AC power from all inverters **90** and **91** is sent to the power grid **104** via the AC powerline **100** and the power service panel **102**. When the grid is down, the AC power from the off-grid AC output port of the on/off-grid power inverter **91** powers the AC loads **108** via the AC powerline **106**.

[0052] FIG. 6 is a block diagram illustrating a grid-flexible power inversion and optimization system where 2 or more m-channel on/off-grid power inverters daisy-chain to form a group, each of the inverters inverts the DC power from m DC sources to AC power, where the combined AC power from the on-grid outputs of all inverters is sent to the electric grid when the grid is on, and when the grid is down, AC power from the off-grid output of each of the inverters powers its corresponding connected AC loads, according to an embodiment of this invention.

[0053] Without losing generality, the system comprises 2 or more m-channel on/off-grid power inverters **110**, each of which has m DC power input channels **116** that are connected to m corresponding DC power sources **118**, respectively. Each power inverter **110** comprises an on-grid AC power input port **113** or **115**, an on-grid AC power output port **111** or **112**, and an off-grid AC power output port **114**. The on/off-grid power inverters can daisy chain, where an inverter's on-grid AC output port **112** connects to the next inverter's on-grid AC input port **113**, and so on. The first inverter's on-grid AC input port **115** is left open, and the last inverter's on-grid AC output port **111** is connected to an AC power service panel **122** so that the generated AC power can be sent to the power grid **124**. Although we say the on/off-grid power inverters daisy chain, where the on-grid AC output port of each inverter is connected to the on-grid AC input port of the next inverter, the actual AC connection of inverters is in parallel or pass-through. That means, all on-grid AC outputs are combined in parallel with an on-grid AC powerline **120** that is connected to the grid **124** through the electric service panel **122**.

[0054] The off-grid AC output port **114** of each power inverter is connected to an off-grid AC powerline **126** individually to form multiple off-grid AC circuits. The system also comprises a power service panel **122**, a power grid **124**, and multiple AC loads **128**.

[0055] In this system, each on/off-grid power inverter takes DC power from its corresponding DC power sources, inverts the DC power to AC power, and outputs the AC power through either the on-grid AC output or off-grid AC output depending on the grid condition. When the grid is on, the combined AC power from all inverters is sent to the

power grid **124** via the AC powerline **120** and the power service panel **122**. When the grid is down, the AC power from the off-grid AC output of each inverter powers its corresponding AC loads **128** via the AC powerline **126**, respectively.

[0056] This design shows that the on-grid AC outputs of all on/off-grid power inverters can be combined in parallel with a daisy-chain design using appropriate AC wires and connectors to make the installation more user-friendly. On the other hand, each on/off-grid power inverter can form and support its own off-grid AC circuit to power AC loads separately. Having multiple individually supported off-grid circuits can be useful in real applications.

[0057] FIG. 7 is a block diagram illustrating a grid-flexible power inversion and optimization system where 2 or more m-channel on/off-grid power inverters are arranged as a group, each of the inverters inverts the DC power from m DC sources to AC power, where the combined AC power from the on-grid outputs of all inverters is sent to the electric grid when the grid is on, and when the grid is down, single or multiple off-grid outputs from their corresponding inverters are combined to form 2 or more off-grid circuits to power the connected AC loads, respectively, according to an embodiment of this invention.

[0058] Without losing generality, the system comprises 2 or more m-channel power inverters **130** and **131**, each of which has m DC power input channels **136** or **137** that are connected to m corresponding DC power sources **138** or **139**, respectively. Each power inverter **130** comprises an on-grid AC power output port **132** and an off-grid AC power output port **134**. Each power inverter **131** comprises an on-grid AC power output port **133** and an off-grid AC power output port **135**. The on-grid AC outputs from all power inverters **130** and **131** are combined in parallel with an on-grid AC powerline **140**. The off-grid AC outputs from all power inverters **130** are combined in parallel with an off-grid AC powerline **146**. The off-grid AC outputs from all power inverters **131** are combined in parallel with an off-grid AC powerline **147**. To simplify the drawing, FIG. 7 shows only one power inverter **131**, although there can be multiple power inverters **131**. The system also comprises a power service panel **142**, a power grid **144**, AC loads **148** and **149**.

[0059] In this system, each on/off-grid power inverter takes DC power from its corresponding DC power sources, inverts the DC power to AC power, and outputs the AC power through either the on-grid AC output or off-grid AC output depending on the grid condition. When the grid is on, the combined AC power from all inverters **130** and **131** is sent to the power grid **144** via the AC powerline **140** and the power service panel **142**. When the grid is down, the combined AC power from all inverters **130** powers the AC loads **148** via the AC powerline **146**, and the combined AC power from all inverters **131** powers the AC loads **149** via the AC powerline **147**.

[0060] This design shows that the on-grid outputs of all inverters can be combined in parallel to send the combined total AC power to the grid. On the other hand, two or more off-grid AC power circuits can be formed by combining the off-grid AC outputs from one or multiple on/off-grid power inverters separately. Having multiple off-grid circuits with different power levels can be useful in real applications in order to deal with AC loads that have different power levels and requirements.

[0061] FIG. 8 is a block diagram illustrating a smart single-channel on/off-grid power inverter that inverts the DC power from one DC source to AC power and supplies the AC power either through its on-grid AC output port or off-grid AC output port, according to an embodiment of this invention.

[0062] The smart single-channel on/off-grid power inverter comprises a DC-DC boost converter **164**, a DC power combiner **166**, a DC-AC inverter **168**, a load interface circuit **170**, an internal on-grid AC powerline **172**, an on-grid electric relay **174**, a digital microcontroller **176**, a line sensing circuit **178**, an interface circuit for powerline communications **180**, a powerline communications Modem **182**, a load detector **184**, an internal off-grid AC powerline **186**, an off-grid electric relay **188**, an external on-grid AC powerline **190**, an external off-grid AC powerline **192**, a DC power supply **194**, and a 3-position manual switch **196**. The external on-grid AC powerline **190** is connected to an electric grid, and the external off-grid AC powerline **192** is connected to an off-grid AC circuit.

[0063] The on-grid electric relay **174** controlled by the microcontroller **176** is used to isolate the internal on-grid AC powerline **172** from the external on-grid AC powerline **190**. The off-grid electric relay **188** controlled by the microcontroller **176** is used to isolate the internal off-grid AC powerline **186** from the external off-grid AC powerline **192**. The internal on-grid AC powerline **172** and internal off-grid AC powerline **186** are connected. However, the AC voltage on the internal powerline **172** and **186** is dependent on whether the inverter is running in the on-grid or off-grid mode. For instance, in the on-grid mode, the internal powerline **172** is 240V, which matches the grid voltage in the U.S. In the off-grid mode, the internal powerline **186** is 120V which is the rated off-grid AC output voltage for the inverter to power 120V AC loads.

[0064] During normal operating conditions, the power from DC source **162** is delivered to the DC-DC boost converter **164** and goes through a DC power combiner **166**. Then, the DC power is inverted by the DC-AC inverter **168** to AC power. In the on-grid mode, the inverted AC voltage is higher than the incoming AC voltage from the electric grid. The generated AC power goes through the load interface circuit **170** to be combined with the AC power in the internal AC powerline **172**. A line sensing circuit **178** connected to the internal AC powerline **172** is used to detect the phase and zero-crossing point of the incoming AC power from the power grid. The phase and zero-crossing point signals are sent to the microcontroller **176** for AC power synchronization to assure that the power inverter provides high quality synchronized power to the grid. The line sensing circuit **178** is also connected to the external AC powerline **190** to detect the power grid status. This signal is useful when the on-grid electric relay **174** is open and the grid status cannot be detected from the internal AC powerline **172**. In the off-grid mode, the inverted AC voltage is regulated based on the rated off-grid output voltage of the power inverter. A smart and scalable off-grid power inverter is disclosed in the U.S. patent application Ser. No. 13/493,622, to power electrical devices including lights, fans, TVs, computers, battery chargers, refrigerators, motors, pumps, and home appliances.

[0065] The 3-position manual switch **196** and the one to be described in FIG. 10 are used to select the power inverter to work in the following positions: (1) auto position, (2)

on-grid position, and (3) off-grid position. In the auto position, the microcontroller can switch between the on-grid and off-grid mode based on the grid condition. In the on-grid position, the power inverter will work as an on-grid inverter. When the grid is down, it will not switch to the off-grid mode. It must be switched to the off-grid mode manually in order for the inverter to generate power to the AC load. In the off-grid position, the inverter will work like an off-grid inverter regardless of the power grid condition. It must be switched to the on-grid mode manually in order for the inverter to generate power to the grid.

[0066] The 3-position manual switch **196** is connected to the microcontroller **176** through signal lines to inform the microcontroller of the selected position. For example, the system can be designed to use 0V, 2.5V, and 3.3V DC signals to switch among the (1) auto position, (2) on-grid position, and (3) off-grid position, respectively.

[0067] As a case example in the following, we assume the inverter is selected in the auto position. During the start-up period, the inverter is not generating power, and both electric relays **174** and **188** are open. The microcontroller **176** first detects if there is grid power from the line sensing circuit **178** connected to the external on-grid AC powerline **190**. If there is grid power, the microcontroller **176** will switch the inverter to the on-grid mode. It will then start the inverter's startup sequence, wait for the 5-minute mandatory waiting period, and then generate AC power to be sent to the grid.

[0068] During the on-grid mode, the on-grid electric relay **174** is closed and off-grid electric relay **188** is open. The microcontroller **176** keeps detecting if there is grid power from the line sensing circuit **178** connected to the internal on-grid AC powerline **172**. If there is grid power, it will continue to send power to the grid. As soon as it detects the grid is down, it will stop generating power within a fraction of a second based on the UL1741 requirement. Then, the microcontroller sends a signal to disconnect the on-grid electric relay **174**. After waiting for a few seconds, the microcontroller sends a signal to connect the off-grid electric relay **188**. The inverter then starts to send a test signal through the internal off-grid powerline **186** and external off-grid powerline **192** to a connected off-grid AC circuit to check: (1) if there is AC present in the off-grid circuit, and (2) if there is an AC load in the off-grid circuit. If there is no AC present and an AC load is detected, it will start to generate AC power to power the load. Now, the inverter is working in the off-grid mode.

[0069] The load detector **184** as well as the ones to be described in FIGS. **9** and **10** are electronic circuits that can detect the impedance of the connected AC load. If no AC power is detected on the off-grid AC powerline, the load detector checks the impedance of the off-grid AC powerline to determine if the connected AC load is within certain specifications. The load detector in the embodiments herein can be designed using standard LRC meter impedance measurement circuits and mechanism such as those described in the book, "The measurement of Lumped Parameter Impedance: A Metrology Guide" published by University of Michigan Library in January 1974.

[0070] During the off-grid mode, the on-grid electric relay **174** is open and off-grid electric relay **188** is closed. The microcontroller **176** is constantly detecting if there is grid power from the line sensing circuit **178** connected to the external on-grid AC powerline **190**. After grid power is detected, the inverter will wait for a few minutes to assure

the grid is stable. When the manual switch **196** is set in the auto position, the inverter is designed to go back to the on-grid mode automatically; it will first stop generating power to the off-grid circuit. After the microcontroller assures that power generation is halted, it will send a signal to disconnect the off-grid electric relay **188**. Then, the microcontroller sends a signal to connect the on-grid electric relay **174**. After a 5-minute mandatory waiting period, the inverter starts to generate AC power to be sent to the power grid. Now, the inverter is working in the on-grid mode.

[0071] The on-grid electric relays and off-grid electric relays to be described in FIGS. **9** and **10** work the same way as described here.

[0072] A powerline communications Modem **182**, which is isolated by an interface circuit **180**, is used to establish a 2-way digital signal communication between the microcontroller **176** and the outside world through the AC powerline. The internal DC power supply **194** takes DC power from the DC power combiner **166** to supply DC power to the internal electronics.

[0073] The digital microcontroller **176** is used to perform a number of tasks including (i) monitoring the DC boost voltage from the DC-DC boost converter, (ii) controlling the DC-DC boost converter, (iii) measuring input voltage and current, and calculating DC input power for the input channel, (iv) performing maximum power point tracking (MPPT) for each solar panel, if the connected DC source is a solar panel, (v) performing DC-AC inversion, AC power synchronization, and AC output current control, (vi) monitoring AC current and voltage for generated power amount and status, (vii) performing powerline communications, (viii) performing logic controls such as AC powerline switching and isolation, (ix) detecting the power grid status, (x) detecting off-grid AC circuit status, (xi) switching between on-grid and off-grid mode based on the setting of the 3-position manual switch, and (xii) regulating AC output voltage when working in the off-grid mode.

[0074] The digital microcontroller **176** as well as those to be described in FIGS. **9**, **10** and **11** are small computers on a single integrated circuit (IC) or a set of ICs that consists of a central processing unit (CPU) combined with functions and peripherals including a crystal oscillator, timers, watchdog, serial and analog I/Os, memory modules, pulse-width-modulation (PWM) generators, and user software programs. A 32-bit high-performance floating-point microcontroller is selected for this application. The digital microcontroller performs real-time control and optimization functions for the on/off-grid power inverter, in which Model-Free Adaptive (MFA) controllers are used to control the DC-DC boost converter, the inverter's on-grid AC output, and the inverter's off-grid AC output. The MFA optimizers provide maximum power point tracking (MPPT) to allow the power inverter to achieve optimal power production. The MFA control and optimization technologies have been described in U.S. Pat. Nos. 6,055,524, 6,556,980, 7,142,626, 7,152,052, 7,415,446, 8,594,813, related international patents, and other issued and pending patents.

[0075] The AC power and related electric grid and AC load in this embodiment and in the embodiments to be described in FIGS. **9**, **10**, and **11** can be single-phase, split-phase, or 3-phase. The 2 AC wires in the drawing are there to show the concept and method.

[0076] FIG. **9** is a block diagram illustrating a smart 4-channel on/off-grid power inverter that inverts the DC

power from four DC sources to AC power and supplies the AC power either through its on-grid AC output port or off-grid AC output port, according to an embodiment of this invention.

[0077] The smart 4-channel on/off-grid power inverter comprises four DC-DC boost converters **201, 202, . . . , 204**, a DC power combiner **206**, a DC-AC inverter **208**, a load interface circuit **210**, an internal on-grid AC powerline **212**, an on-grid electric relay **214**, a digital microcontroller **216**, a line sensing circuit **218**, an interface circuit for powerline communications **220**, a powerline communications Modem **222**, a load detector **224**, an internal off-grid AC powerline **226**, an off-grid electric relay **228**, an external on-grid AC powerline **230**, an external off-grid AC powerline **232**, and a DC power supply **234**. The external on-grid AC powerline **230** is connected to an electric grid, and the external off-grid AC powerline **232** is connected to an off-grid AC circuit.

[0078] The on-grid electric relay **214** controlled by the microcontroller **216** is used to isolate the internal on-grid AC powerline **212** from the external on-grid AC powerline **230**. The off-grid electric relay **228** controlled by the microcontroller **216** is used to isolate the internal off-grid AC powerline **226** from the external off-grid AC powerline **232**. The internal on-grid AC powerline **212** and internal off-grid AC powerline **226** are connected. However, the AC voltage on the internal powerline **212** and **226** is dependent on whether the inverter is running in the on-grid or off-grid mode.

[0079] During normal operating conditions, the power from DC sources **197, 198, . . . , 200** is delivered to the corresponding DC-DC boost converters **201, 202, . . . , 204** respectively. The DC power is then combined in the DC power combiner **206**. The combined DC power is then inverted by the DC-AC inverter **208** to AC power. In the on-grid mode, the inverted AC voltage is higher than the incoming AC voltage from the grid. The generated AC power goes through the load interface circuit **210** to be combined with the AC power in the internal AC powerline **212**. A line sensing circuit **218** connected to the internal AC powerline **212** is used to detect the phase and zero-crossing point of the incoming AC power from the power grid. The phase and zero-crossing point signals are sent to the microcontroller **216** for AC power synchronization to assure that the power inverter provides high quality synchronized power to the grid. The line sensing circuit **218** is also connected to the external AC powerline **230** to detect the power grid status. In the off-grid mode, the inverted AC voltage is regulated based on the rated off-grid output voltage of the power inverter.

[0080] There is no 3-position manual switch in this design to show that the power inverter can be designed to switch between the on-grid and off-grid automatically without human interaction. The operations of the on-grid electric relay **214**, off-grid electric relay **228**, their corresponding internal and external AC powerlines, and power generation sequences have been described in FIG. 8.

[0081] A powerline communications Modem **222**, which is isolated by an interface circuit **220**, is used to establish a 2-way digital signal communication between the microcontroller **216** and the outside world through the AC powerline. The internal DC power supply **234** takes DC power from the DC power combiner **206** to supply DC power to the internal electronics.

[0082] The digital microcontroller **216** and the one to be described in FIG. 10 are used to perform a number of tasks

including (i) monitoring the DC boost voltage from each DC-DC boost converter, (ii) controlling the DC-DC boost converters, (iii) measuring input voltage and current, and calculating DC input power for each input channel, (iv) performing maximum power point tracking (MPPT) for each solar panel, if the connected DC source is a solar panel, (v) performing DC-AC inversion, AC power synchronization, and AC output current control, (vi) monitoring AC current and voltage for generated power amount and status, (vii) performing powerline communications, (viii) performing logic controls such as AC powerline switching and isolation, (ix) detecting the power grid status, (x) detecting off-grid AC circuit status, (xi) switching between on-grid and off-grid mode, and (xii) regulating AC output voltage when working in the off-grid mode.

[0083] The DC-DC boost converters that can be used in the embodiments herein are any of a number of well known converters described in the "Power Electronics Handbook" edited by Muhammad H. Rashid, published by Academic Press in 2007, including Buck Converter, Boost Converter, Buck-Boost Converter, Super-Lift Luo Converter, and Cascade Boost Converter. The DC-AC inverters that can be used in the embodiments herein are any of a number of well known DC-AC inverters described in the "Power Electronics Handbook" including Half-Bridge Inverter, Full-Bridge Inverter, Bipolar PWM Inverter, Unipolar PWM Inverter, and Sinusoidal PWM Inverter. The DC combiners used in the embodiments herein can be designed with a circuit that allow the output from all DC-DC boost converters to connect in parallel so that all DC currents will be added together. The Powerline Modem that can be used in the embodiments herein can be any of a number of commercially available integrated circuits capable of providing 2-way digital communications through a powerline. Other modules discussed in the embodiments herein including load interface, solid state switch, line sensing circuit, powerline interface circuit, load detector, on-grid relay, off-grid relay, and DC power supply can be implemented using one or more known combinations of conventional electronic components such as resistors, capacitors, inductors, solid-state switches, transformers, diodes, transistors, operational amplifiers, and ceramic filters, etc.

[0084] The function of regulating AC output voltage in the off-grid mode is achieved by the digital microcontroller with its supporting circuits and software to perform the following: (i) measuring the AC output voltage in real-time; (ii) comparing it with the rated AC output voltage setpoint such as 120V; and (iii) adjusting the AC output current or output power until the output voltage is regulated around its setpoint within a specified deadband. More specifically, if the AC output voltage is higher than its setpoint, the microcontroller will reduce the output current by decreasing the duty-cycle of the pulse-width-modulation (PWM) of the DC-DC boost converter. If the AC output voltage is lower than its setpoint, it will increase the duty-cycle of PWM to increase the AC output current. If the AC output voltage is within the deadband of its setpoint such as 120V \pm 1V, the microcontroller will not make PWM duty-cycle adjustments to keep the AC output current and AC output power stable. Based on the Ohm's Law, the AC output voltage is in proportion of the AC output current so that it can be regulated accordingly.

[0085] If the power inverter is used for solar power applications, the available DC input power from each input

channel will vary due to sunlight variations. On the other hand, the total AC loads may change quickly and frequently as well. The automatic control system to regulate inverter's output voltage for the on/off-grid power inverter in the off-grid mode can be difficult to implement. The Model-Free Adaptive (MFA) controllers described in U.S. Pat. Nos. 6,055,524, 6,556,980, and subsequent patents are implemented in the digital microcontroller to achieve robust control performance for AC output voltage regulation.

[0086] FIG. 10 is a block diagram illustrating a smart m-channel on/off-grid power inverter that inverts the DC power from m DC sources to AC power and supplies the AC power either through its on-grid AC output port or off-grid AC output port, according to an embodiment of this invention.

[0087] The smart m-channel on/off-grid power inverter comprises m DC-DC boost converters **241**, **242**, . . . , **244**, a DC power combiner **246**, a DC-AC inverter **248**, a load interface circuit **250**, an internal on-grid AC powerline **252**, an on-grid electric relay **254**, a digital microcontroller **256**, a line sensing circuit **258**, an interface circuit for powerline communications **260**, a powerline communications Modem **262**, a load detector **264**, an internal off-grid AC powerline **266**, an off-grid electric relay **268**, an external on-grid AC powerline **270** and **271**, an external off-grid AC powerline **272**, a DC power supply **274**, and a 3-position manual switch **276**. The external on-grid AC powerline **270** and **271** is connected to an electric grid, and the external off-grid AC powerline **272** is connected to an off-grid AC circuit.

[0088] The on-grid electric relay **254** controlled by the microcontroller **256** is used to isolate the internal on-grid AC powerline **252** from the external on-grid AC powerline **270** and **271**. The off-grid electric relay **268** controlled by the microcontroller **256** is used to isolate the internal off-grid AC powerline **266** from the external off-grid AC powerline **272**. The internal on-grid AC powerline **252** and internal off-grid AC powerline **266** are connected. However, the AC voltage on the internal powerline **252** and **266** is dependent on whether the inverter is running in the on-grid or off-grid mode.

[0089] FIG. 10 illustrates that the same external AC powerline can have 2 connected pairs of AC wires **270** and **271** to facilitate AC input and AC output ports for daisy-chaining multiple inverters. That is, the AC output port of an inverter connects to the AC input port of the next inverter, and so on. Although we say the inverters daisy chain, the actual connection of inverter's AC powerline is in parallel or pass-through.

[0090] The on-grid relay **254**, external AC powerline **270**, and their supporting circuits can form an on-grid AC output port. The on-grid relay **254**, external AC powerline **271**, and their supporting circuits can form an on-grid AC input port. In physical design of an on/off-grid power inverter, the AC input port and AC output port can be constructed by using appropriate AC wires and connectors to make the installation more user-friendly. For instance, the AC output port can use a male-type AC connector and the AC input port can use a female-type AC connector, which make a matching pair. This way, the user can easily make the AC connections and avoid potential errors. The drawing of external AC powerline **270** and **271** in FIG. 10 shows the concept of how multiple on/off-grid power inverters can daisy-chain as illustrated in FIG. 6. The drawings in FIGS. 8 and 9 show only two wires for the external AC powerline but the same

type of AC input and output ports can be built in a similar way. The drawings in FIGS. 12 to 15 show external AC powerlines and describe on-grid AC output ports. To simplify the drawings, on-grid AC input ports are not shown, but can be implemented the same way.

[0091] During normal operating conditions, the power from DC sources **237**, **238**, . . . , **240** is delivered to the corresponding DC-DC boost converters **241**, **242**, . . . , **244** respectively. The DC power is then combined in the DC power combiner **246**. The combined DC power is then inverted by the DC-AC inverter **248** to AC power. In the on-grid mode, the inverted AC voltage is higher than the incoming AC voltage from the grid. The generated AC power goes through the load interface circuit **250** to be combined with the AC power in the internal AC powerline **252**. A line sensing circuit **258** connected to the internal AC powerline **252** is used to detect the phase and zero-crossing point of the incoming AC power from the power grid. The phase and zero-crossing point signals are sent to the microcontroller **256** for AC power synchronization to assure that the power inverter provides high quality synchronized power to the grid. The line sensing circuit **258** is also connected to the external AC powerline **270** to detect the power grid status. In the off-grid mode, the inverted AC voltage is regulated based on the rated off-grid output voltage of the power inverter.

[0092] The 3-position manual switch **276** has been described in FIG. 8. It is connected to the microcontroller **256** through signal lines to inform the microcontroller of the selected auto, on-grid, or off-grid positions. The operations of the on-grid electric relay **254**, off-grid electric relay **268**, their corresponding internal and external AC powerlines, and power generation sequences have been described in FIG. 8.

[0093] A powerline communications Modem **262**, which is isolated by an interface circuit **260**, is used to establish a 2-way digital signal communication between the microcontroller **256** and the outside world through the AC powerline. The internal DC power supply **274** takes DC power from the DC power combiner **246** to supply DC power to the internal electronics.

[0094] FIG. 11 is a block diagram illustrating a smart m-channel on-grid power inverter that inverts the DC power from m DC sources to AC power to be sent to the electric grid, where the inverter's external AC powerline shows 2 pairs of AC wires.

[0095] The smart m-channel on-grid power inverter comprises m DC-DC boost converters **281**, **282**, . . . , **284**, a DC power combiner **285**, a DC-AC inverter **286**, a load interface circuit **287**, an internal AC powerline **288**, a solid state switch **289**, a digital microcontroller **290**, a line sensing circuit **291**, an interface circuit for powerline communications **292**, a powerline communications Modem **293**, a DC power supply **294**, and an external AC powerline **296** and **297**.

[0096] The m-channel on-grid power inverters are disclosed in U.S. Pat. No. 8,786,133 and subsequent patent applications. FIG. 11 makes it more clear by showing the same external AC powerline can have 2 pairs of AC wires **296** and **297** to facilitate AC input and output ports for daisy-chaining multiple power inverters. That is, the AC output port of an inverter connects to the AC input port of the next inverter, and so on. Although we say the inverters daisy chain, the actual connection of the inverter's AC

powerline is in parallel or pass-through. FIG. 11 shows the same external AC powerline has 2 pairs of AC wires 296 and 297 connected in parallel.

[0097] In FIG. 11, the solid-state relay 289, external AC powerline 296, and their supporting circuits can form an AC output port. The solid-state relay 289, external AC powerline 297, and their supporting circuits can form an AC input port. In physical design of an on-grid power inverter, the AC input port and AC output port can be constructed by using appropriate AC wires and connectors to make the installation user-friendly. For instance, the AC output port can use a male-type AC connector and the AC input port can use a female-type AC connector, making a matching pair. This way, the user can easily make the AC connections and avoid potential errors. The drawing of the external AC powerline 296 and 297 in FIG. 11 shows the concept of how multiple power inverters can daisy-chain as illustrated in FIG. 5.

[0098] FIG. 12 is a block diagram illustrating an on/off-grid power inverter's on-grid AC output port to supply AC power to an electric grid with split-phase AC, and inverter's off-grid AC output port to supply AC power to single-phase AC loads, according to an embodiment of this invention.

[0099] In North America and some other parts of the world, split-phase AC standard is used. A split-phase system is also called single-phase three-wire system for electric power distribution. Originated from Thomas Edison's three-wire DC system, the split-phase AC system has some advantages over the single-ended single-phase AC system. For the split-phase system, as an example, the line-to-line (L1 to L2) output voltage is 240V, and the Line-to-Neutral (L1 to N, or L2 to N) is 120V. Therefore, the on/off-grid power inverters to be used in North America must support the split-phase AC for its on-grid AC output and support single-phase AC for its off-grid AC output.

[0100] In FIG. 12, the inverter's on-grid AC output port 300 comprises an on-grid electric relay 302, an on-grid control circuit 304, an internal on-grid AC powerline 306, and an external on-grid AC powerline 308. The inverter's off-grid AC output port 310 comprises an off-grid electric relay 312, an off-grid control circuit 314, an internal off-grid AC powerline 316, and an external off-grid AC powerline 318. The external on-grid AC powerline 308 is connected to the L1 and L2 lines of a split-phase power grid. The external off-grid AC powerline 318 is connected with a single-phase off-grid AC circuit. The Neutral line of the split-phase AC that is connected to the power grid and Common line of the single-phase AC of the off-grid circuit are connected to the earth ground 319. The control circuits 304 and 314 are connected to and controlled by a digital microcontroller of the power inverter described in FIGS. 8, 9, and 10.

[0101] The electric relays 302 and 312 as well as those to be described in FIGS. 13, 14, and 15 that can be used in the embodiments herein are any of a number of electric devices to connect and disconnect electric circuits including but not limited to electric relays, contacts, solid-state switches, and TRIAC (bidirectional triode thyristor or bilateral triode thyristor).

[0102] The on-grid and off-grid control circuits 304 and 314 as well as those to be described in FIGS. 13, 14, and 15 convert the digital control signals to appropriate AC or DC signals that can drive the electric relays or the other types of electric connecting and disconnecting devices such as contacts, solid-state switches, and TRIAC.

[0103] Since the described on/off-grid power inverter has on-grid and off-grid modes, switching between the 2 modes can be designed based on automatic or manual switching methods. In FIGS. 8 and 10, a 3-position manual switch is described to select the auto position, on-grid position, or off-grid position. In FIG. 9, the described on/off-grid power inverter is designed to be able to switch between the on-grid and off-grid mode automatically without human interaction.

[0104] As a case example in the following, we assume the inverter can switch between the on-grid and off-grid mode automatically depending on the grid condition. During the start-up period, the inverter is not generating power, and both electric relays 302 and 312 are open. If there is grid power, the inverter will be switched to the on-grid mode and then goes through a startup sequence before generating AC power to be sent to the grid.

[0105] During the on-grid mode, the electric relay 302 is closed and electric relay 312 is open. If there is grid power, the inverter will continue to send power to the grid. As soon as the grid is down, it will stop generating power within a fraction of a second based on the UL1741 requirement. Then, the inverter will send a control signal to disconnect the on-grid electric relay 302 through the on-grid control circuit 304. After waiting a few seconds, it will send a control signal to connect the off-grid electric relay 312 through the off-grid control circuit 314. The inverter then starts to send a test signal to check: (1) if there is AC present in the off-grid circuit, and (2) if there is an AC load in the off-grid circuit. If there is no AC present and an AC load is detected, it will start to generate power to power the load through the single-phase off-grid circuit. Now, the inverter is working in the off-grid mode.

[0106] During the off-grid mode, the electric relay 302 is open and electric relay 312 is closed. The inverter is constantly detecting if there is grid power. After grid power is detected, the inverter will wait for a few minutes to assure the grid is stable. Then, it will first stop generating power to the off-grid circuit. After the inverter assures that power generation is halted, it will send a signal to disconnect the off-grid electric relay 312 through the off-grid control circuit 314. Then, the inverter sends a signal to close the on-grid electric relay 302 through the on-grid control circuit 304. After a 5-minute mandatory waiting period, the inverter starts to generate power and supplies AC power to split-phase AC power grid. Now, the inverter is working in the on-grid mode.

[0107] The operations of the on-grid AC output port 300, the off-grid AC output port 310, and those on-grid AC output ports and off-grid AC output ports to be described in FIG. 13, 14, 15 are very similar. The differences are mainly related to the single-phase, split-phase, and three-phase AC wiring and related electrical circuits.

[0108] FIG. 13 is a block diagram illustrating an on/off-grid power inverter's on-grid AC output port to supply AC power to a single-phase AC power grid, and inverter's off-grid AC output port to supply AC power to single-phase AC loads, according to an embodiment of this invention.

[0109] In FIG. 13, the inverter's on-grid AC output port 320 comprises an on-grid electric relay 322, an on-grid control circuit 324, an internal on-grid AC powerline 326, and an external on-grid AC powerline 328. The inverter's off-grid AC output port 330 comprises an off-grid electric relay 332, an off-grid control circuit 334, an internal off-grid AC powerline 336, and an external off-grid AC powerline

338. The external on-grid AC powerline **328** is connected to a single-phase power grid. The external off-grid AC powerline **338** is connected with a single-phase off-grid AC circuit. The Common line of the single-phase AC of the power grid and Common line of the single-phase AC of the off-grid circuit are connected to the earth ground **339**. The control circuits **324** and **334** are connected to and controlled by a digital microcontroller.

[0110] Compared with the AC circuits in FIG. **12**, this is a simpler case since both on-grid and off-grid AC are single-phase. This is quite typical for the AC standards in Europe, Asia, and Africa, where single-phase 220V, 230V, 50 Hz AC is used for both on-grid and off-grid modes.

[0111] FIG. **14** is a block diagram illustrating an on/off-grid power inverter's on-grid AC output port to supply AC power to a three-phase AC power grid, and inverter's off-grid AC output port to supply AC power to single-phase AC loads, according to an embodiment of this invention.

[0112] In FIG. **14**, the inverter's on-grid AC output port **340** comprises an on-grid electric relay **342**, an on-grid control circuit **344**, an internal on-grid AC powerline **346**, and an external on-grid AC powerline **348**. The inverter's off-grid AC output port **350** comprises an off-grid electric relay **352**, an off-grid control circuit **354**, an internal off-grid AC powerline **356**, and an external off-grid AC powerline **358**. The external on-grid AC powerline **348** is connected to the L1, L2, and L3 lines of a three-phase power grid. The external off-grid AC powerline **358** is connected with a single-phase off-grid AC circuit. The Neutral line of the three-phase AC of the power grid and Common line of the single-phase AC of the off-grid circuit are connected to the earth ground **359**. The control circuits **344** and **354** are connected to and controlled by a digital microcontroller.

[0113] Compared with the AC circuits in FIGS. **12** and **13**, this is a more complex case since the grid power is three-phase AC and the off-grid electric circuit is single-phase AC.

[0114] FIG. **15** is a block diagram illustrating an on/off-grid power inverter's on-grid AC output port to supply AC power to a three-phase AC power grid, and inverter's off-grid AC output port to supply AC power to three-phase AC loads, according to an embodiment of this invention.

[0115] In FIG. **15**, the inverter's on-grid AC output port **360** comprises an on-grid electric relay **362**, an on-grid control circuit **364**, an internal on-grid AC powerline **366**, and an external on-grid AC powerline **368**. The inverter's off-grid AC output port **370** comprises an off-grid electric relay **372**, an off-grid control circuit **374**, an internal off-grid AC powerline **376**, and an external off-grid AC powerline **378**. The external on-grid AC powerline **368** is connected to the L1, L2, and L3 lines of a three-phase power grid. The external off-grid AC powerline **378** is connected the L1, L2, and L3 lines of a three-phase off-grid AC circuit. The Neutral line of the three-phase AC of the power grid and Neutral line of the three-phase AC of the off-grid circuit are connected to the earth ground **379**. The control circuits **364** and **374** are connected to and controlled by a digital microcontroller.

[0116] Compared with the AC circuits in FIG. **12**, **13**, **14**, this design has three-phase AC for both on-grid and off-grid circuits. Three-phase electric motors are a good example of three-phase AC loads that may run in either on-grid or off-grid modes.

[0117] The applying organization of this patent has built commercial multi-channel on-grid power inverters for on-

grid applications and multi-channel off-grid power inverters for off-grid applications. The described smart and grid-flexible power inverters, or on/off-grid power inverters, take the unique design and concept of multi-channel power inverters to the next level.

[0118] When the on/off-grid power inverters are used in solar power systems, the grid-flexible solar power system can generate AC power regardless of the grid condition. The system can supply generated AC power to the electric power grid when the grid is on or supply AC power to electric devices when the grid is down. The disclosed method and apparatus can significantly improve the usefulness of solar power systems and make them more competitive compared with fossil fuel and other types of renewable energy, resulting in better return-on-investment (ROI) and faster adoption of solar energy in the global market.

[0119] Climate changes in our world are becoming more catastrophic. Power grid brownouts and shutdowns become more frequent and severe, resulting in loss of production and personal hardship. With the on/off-grid power inverters and the grid-flexible solar power systems, we can be more capable of dealing with power grid instability and shutdowns to reduce the disruption to our way of life.

1. A scalable DC to AC power inversion system for providing AC power to the electric grid or to an off-grid AC circuit respectively from a plurality of individual DC power sources each having a DC output port, comprising:

- a) at least one on-grid power inverter, each having at least one DC input port, an on-grid AC input port, and an on-grid AC output port;
- b) at least one on/off-grid power inverter, each having at least one DC input port, an on-grid AC output port, and an off-grid AC output port;
- c) the on-grid AC output port of each inverter being connected in a daisy chain to the on-grid AC input port of the next inverter, except for the on-grid AC output port of the first inverter being connected to the grid;
- d) said on-grid AC output port of the first inverter being arranged to supply AC power produced by all inverters to the grid when the grid is on;
- e) the off-grid AC output port of each on/off-grid power inverter being connected to an off-grid AC circuit and arranged to supply AC power to AC loads in the off-grid circuit when grid is down; and
- f) whereby said system is incrementally scalable by adding or subtracting DC power sources and daisy-chained inverters.

2. The system of claim **1**, further comprising:

- a) a first DC power source connected to one of said DC power input ports of one of said power inverters; and
- b) a second DC power source, different in kind from said first DC power source, connected to another of said DC power input ports of said one power inverter.

3. The system of claim **1**, wherein the output of each said on-grid power inverter and the on-grid output of each said on/off-grid power inverter is single-phase AC or three-phase AC.

4. A method of making a grid-flexible power generation system incrementally scalable, comprising:

- a) connecting a DC power source to each DC input port of a plurality of on/off-grid power inverters, each of the inverters also having an on-grid AC output port and an off-grid AC output port;

- b) combining said on-grid AC output port of all said inverters together so the total produced AC power is the summation of the AC power supplied by each inverter; and
 - c) providing AC power to the electric grid through the combined on-grid AC output ports when the grid is on or providing AC power to one or multiple AC loads, individually, through said off-grid AC output port of each inverter when the grid is down.
- 5.** The method of claim **4**, further comprising:
- a) each of said inverters having an on-grid AC input port;
 - b) combining said on-grid AC output port of all inverters together by daisy-chaining the inverters, said on-grid AC output port of each inverter being connected in a daisy chain to the on-grid AC input port of the next inverter, except for the on-grid AC output port of the first inverter being connected to the electric grid, and the on-grid AC input port of the last inverter being left open; and
 - c) providing AC power to the electric grid through the on-grid AC output port of the first inverter when the grid is on.
- 6.** The method of claim **4**, further comprising:
- a) connecting a first DC power source to one of said DC power input ports of one of said power inverters; and
 - b) connecting a second DC power source, different in kind from said first DC power source, to another of said DC power input ports of said one power inverter.
- 7.** The method of claim **4**, in which the on-grid output of each said power inverter is single-phase 220V-240V 50 Hz/60 Hz AC and the off-grid output of each said power inverter is single-phase 100V-120V 50 Hz/60 Hz AC.
- 8.** The method of claim **4**, in which the on-grid output of each said power inverter is single-phase 220V-240V 50 Hz/60 Hz AC and the off-grid output of each said power inverter is single-phase 220V-240V 50 Hz/60 Hz AC.
- 9.** The method of claim **4**, in which the on-grid output of each said power inverter is three-phase AC and the off-grid output of each said power inverter is single-phase AC.
- 10.** The method of claim **4**, in which the on-grid output of each said power inverter is three-phase AC and the off-grid output of each said power inverter is three-phase AC.
- * * * * *