



US 20200315341A1

(19) **United States**

(12) **Patent Application Publication**
Brennan

(10) **Pub. No.: US 2020/0315341 A1**

(43) **Pub. Date: Oct. 8, 2020**

(54) **TABLE TOP FENCE RAIL SYSTEM**

Publication Classification

(71) Applicant: **Darren T. Brennan**, Massapequa, NY (US)

(51) **Int. Cl.**
A47B 37/04 (2006.01)
A47B 13/00 (2006.01)
E04H 17/14 (2006.01)

(72) Inventor: **Darren T. Brennan**, Massapequa, NY (US)

(52) **U.S. Cl.**
CPC *A47B 37/04* (2013.01); *E04H 2017/006* (2013.01); *E04H 17/1417* (2013.01); *A47B 13/003* (2013.01)

(21) Appl. No.: **16/909,373**

(22) Filed: **Jun. 23, 2020**

(57) **ABSTRACT**

A table top fence rail system includes a fence, a table top including a body having planar top and bottom surfaces. The body defines an opening that extends between the top and bottom planar surfaces and is dimensioned to receive the upper end portion of a respective post of the fence. A cap is supported on the upper end portion of the post and is dimensioned to retain the planar bottom surface of the body of the table top on the upper support surface of the upper horizontal rail of the fence.

Related U.S. Application Data

(62) Division of application No. 16/290,298, filed on Mar. 1, 2019, now Pat. No. 10,687,616.

(60) Provisional application No. 62/769,535, filed on Nov. 19, 2018, provisional application No. 62/726,339, filed on Sep. 3, 2018.

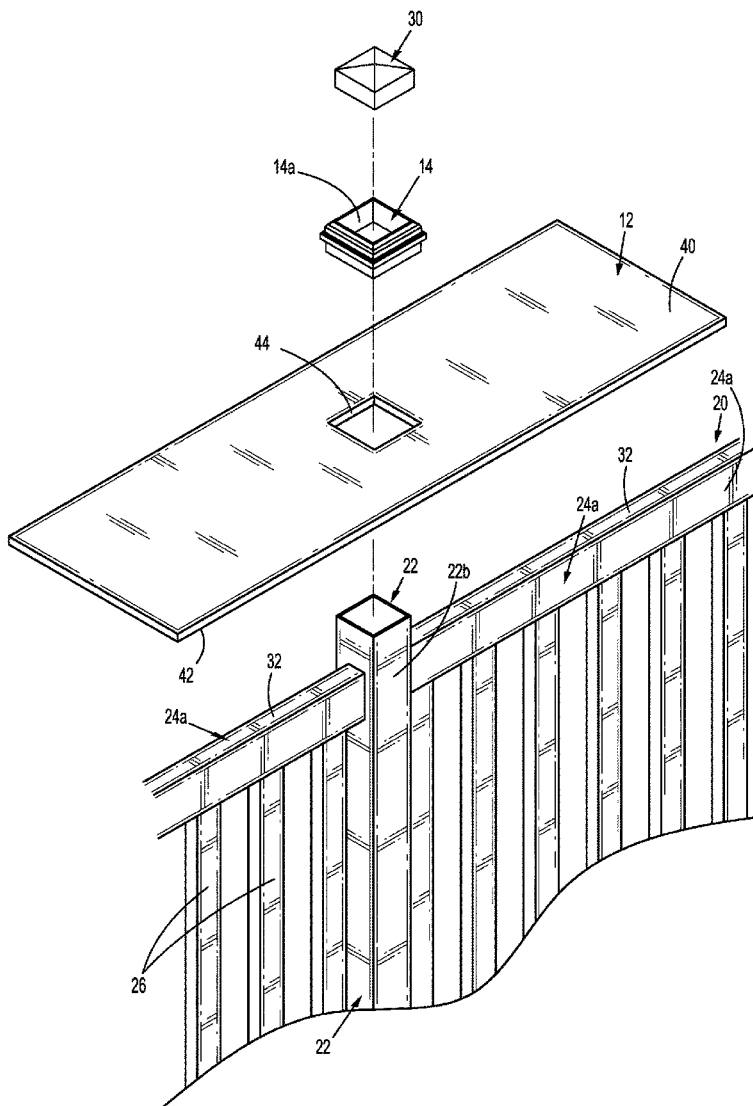

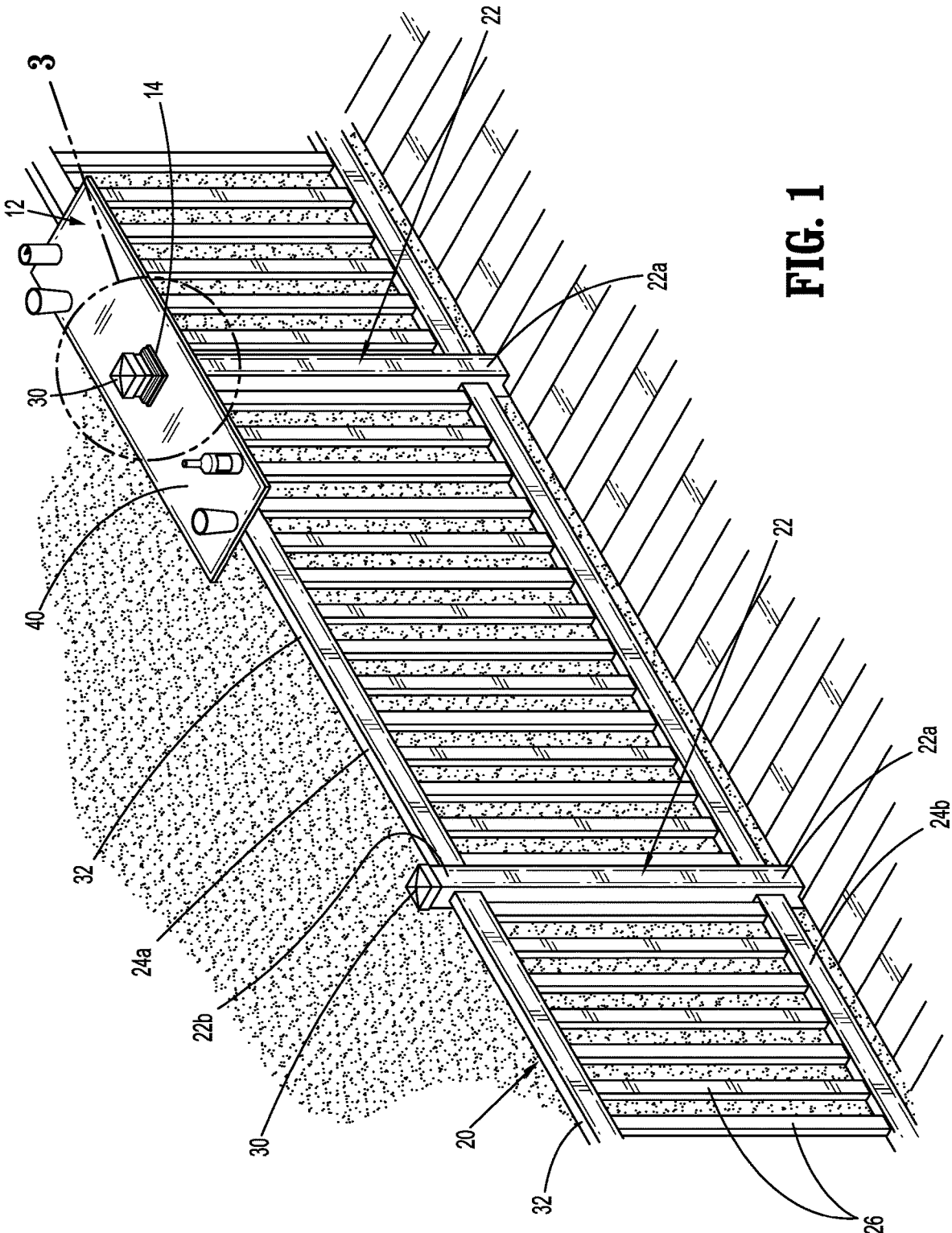

FIG. 1

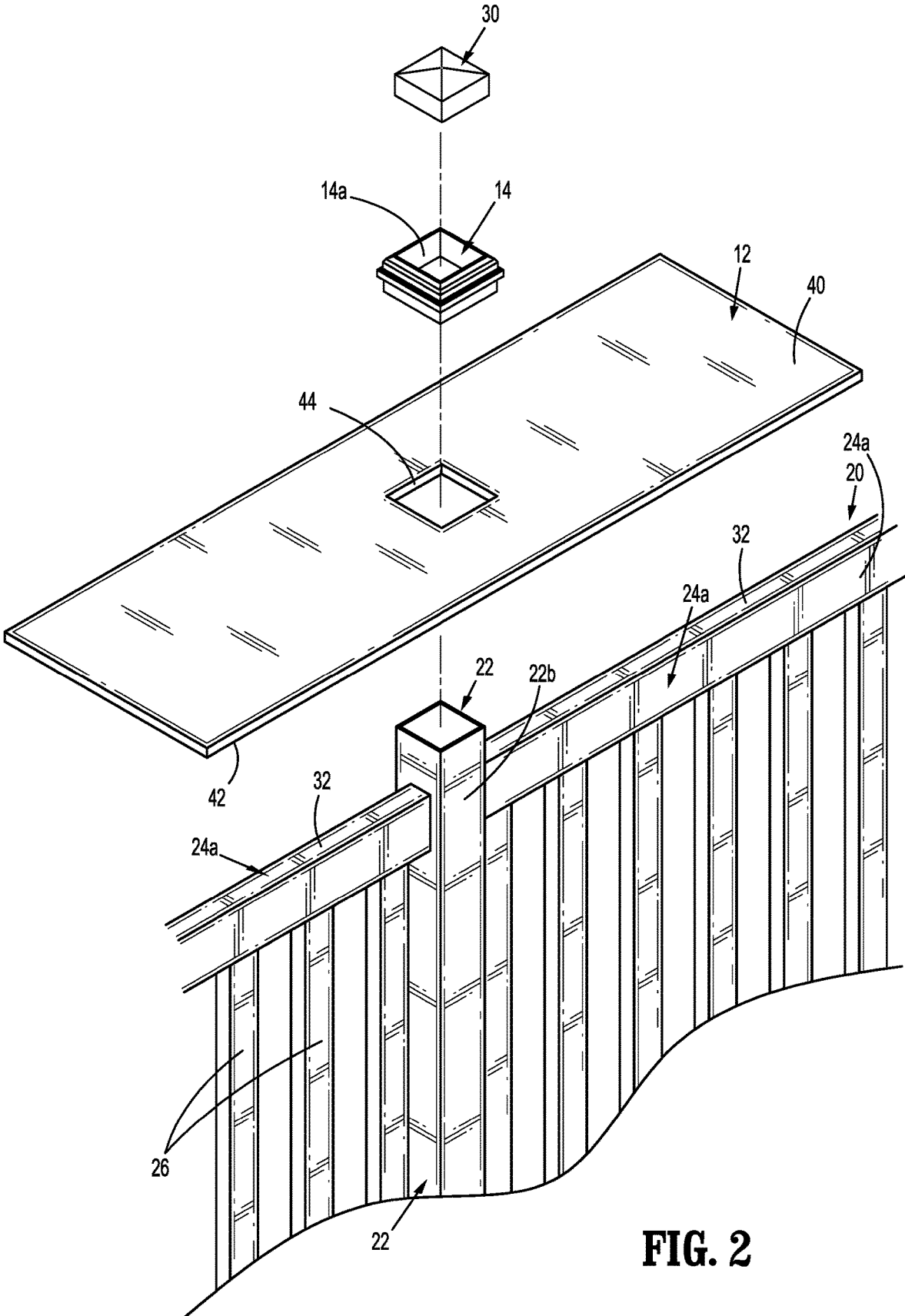
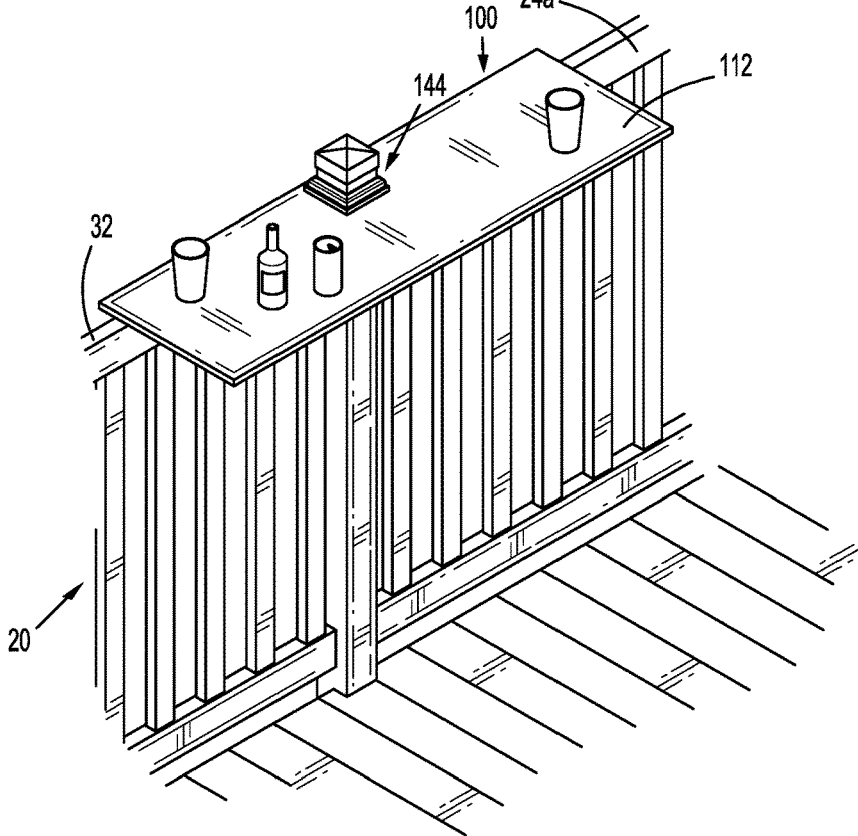
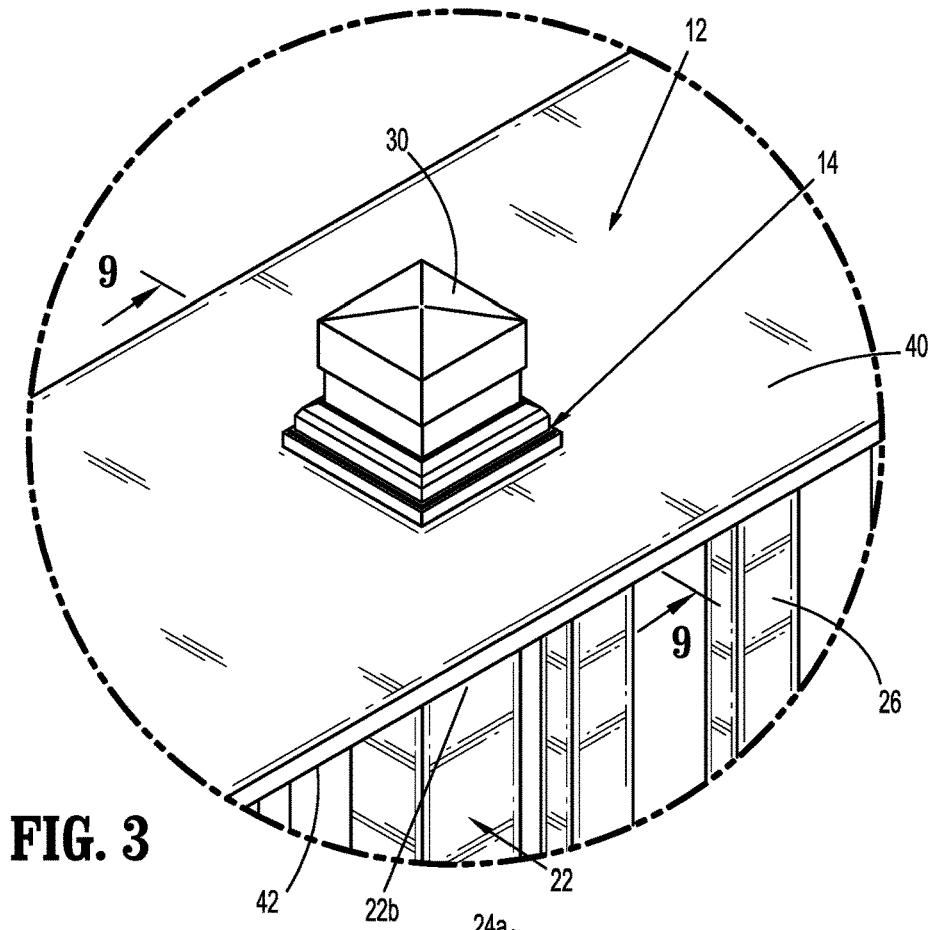

FIG. 2



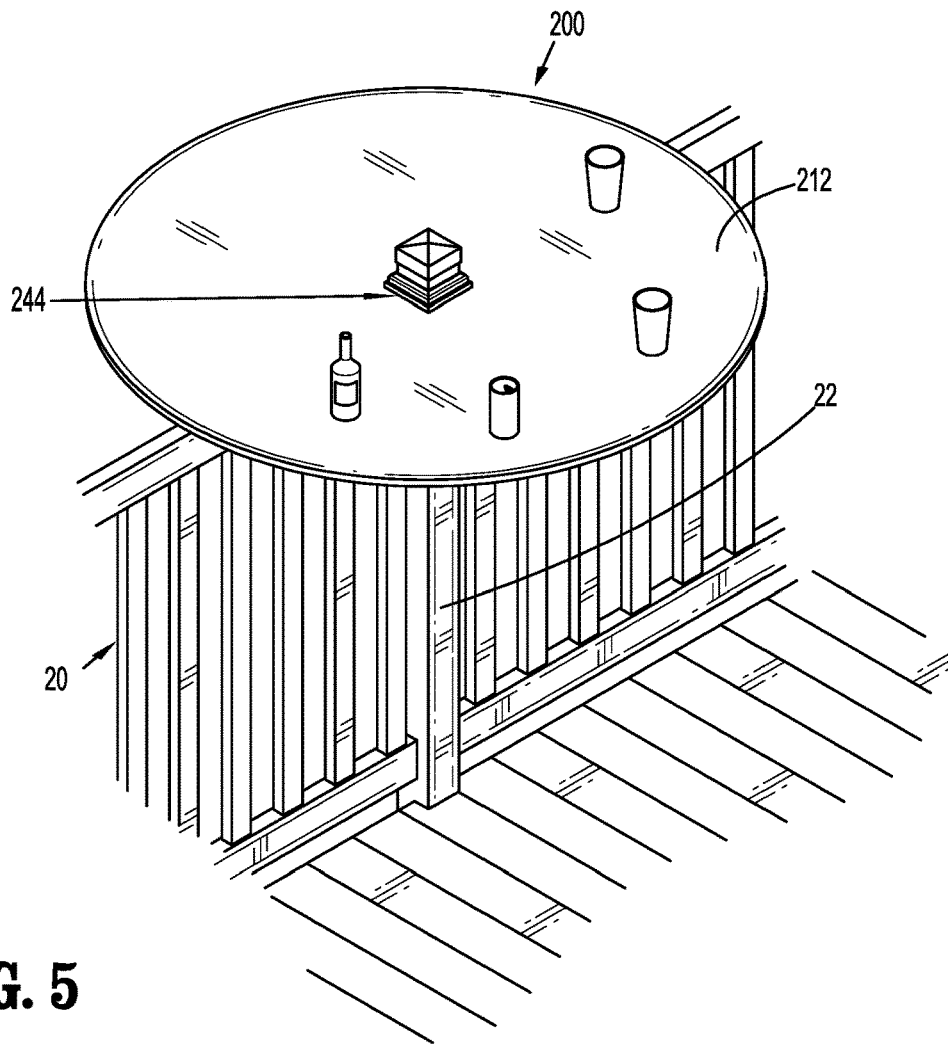

FIG. 5

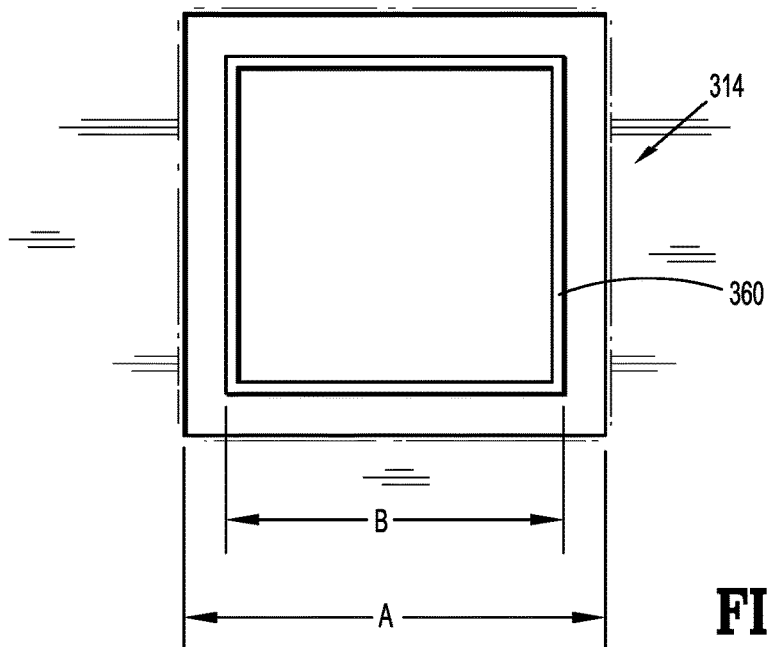

FIG. 6

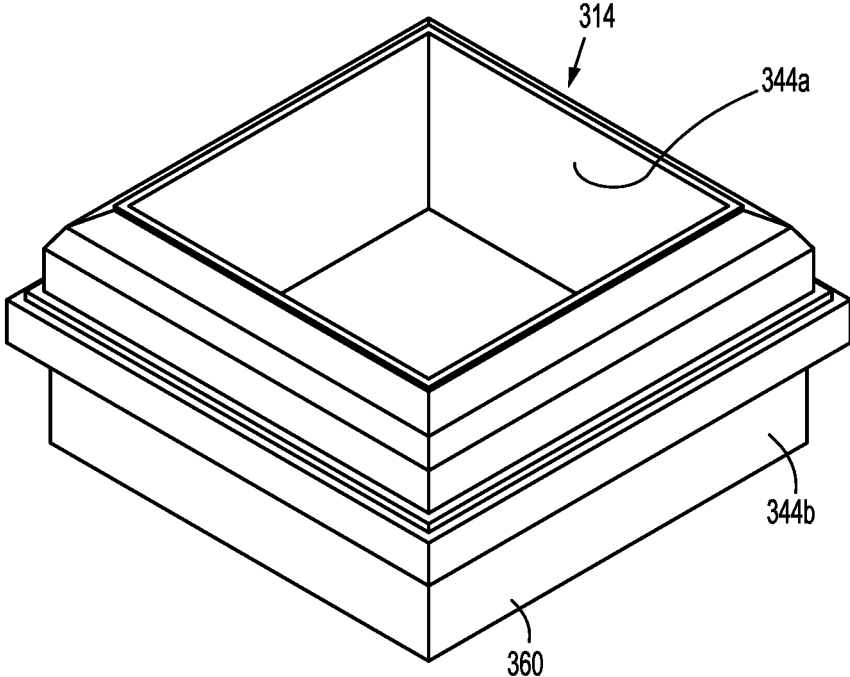

FIG. 7

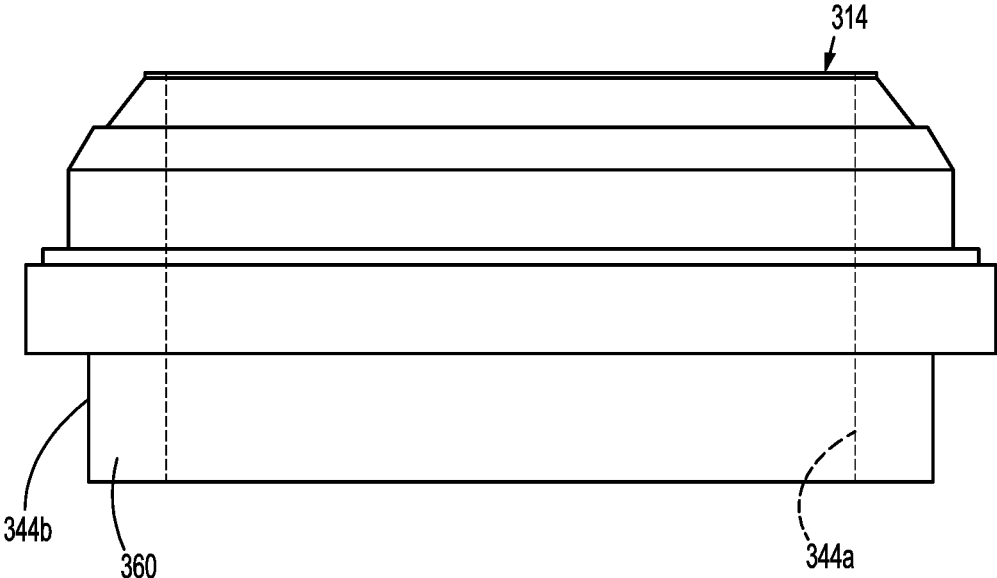

FIG. 8

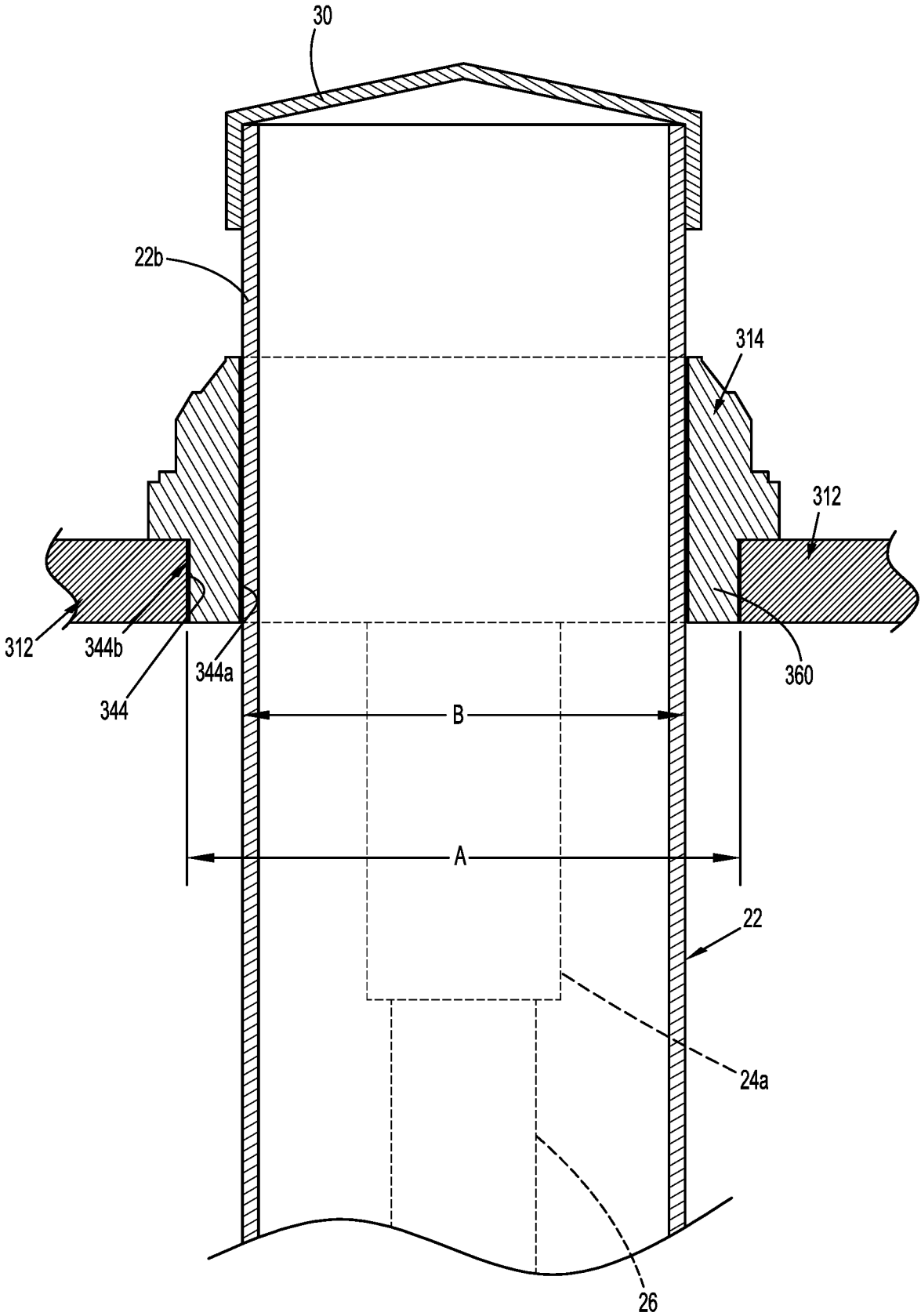

FIG. 9

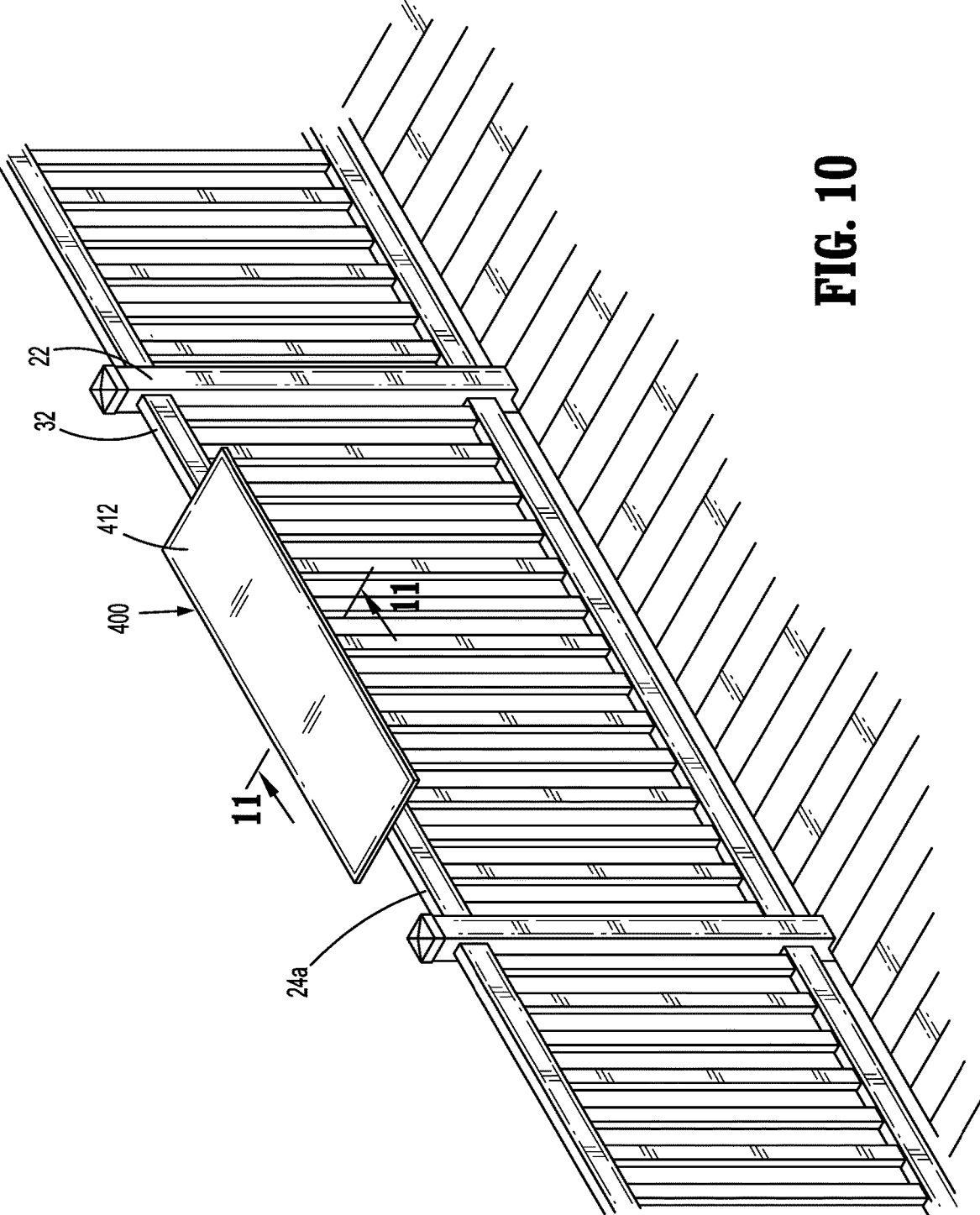

FIG. 10

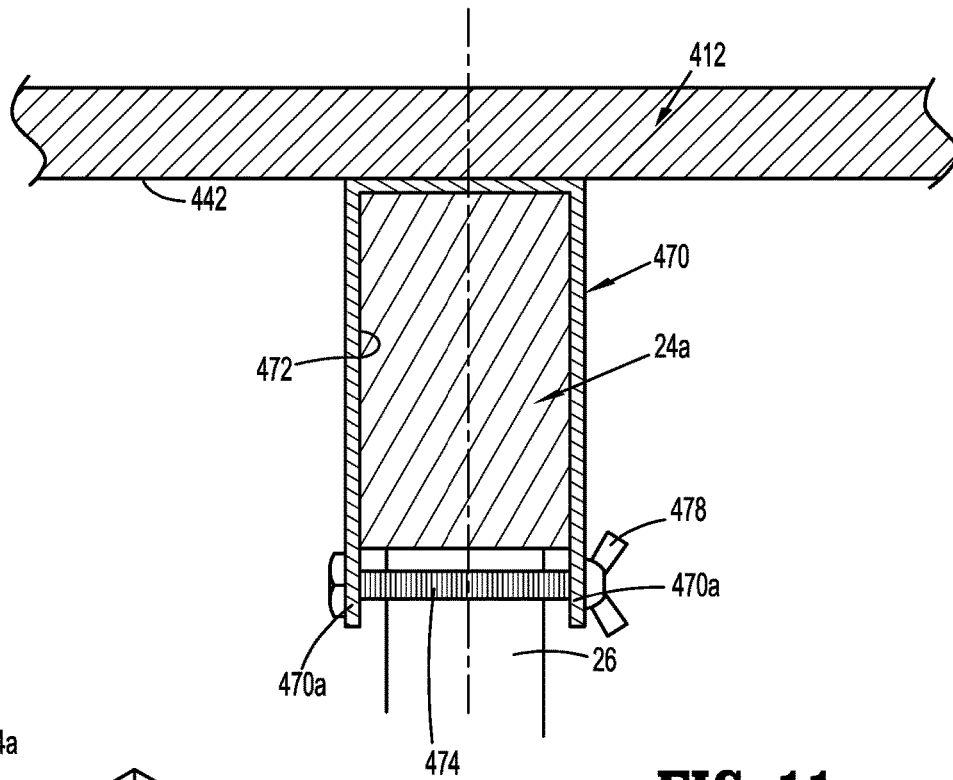

FIG. 11

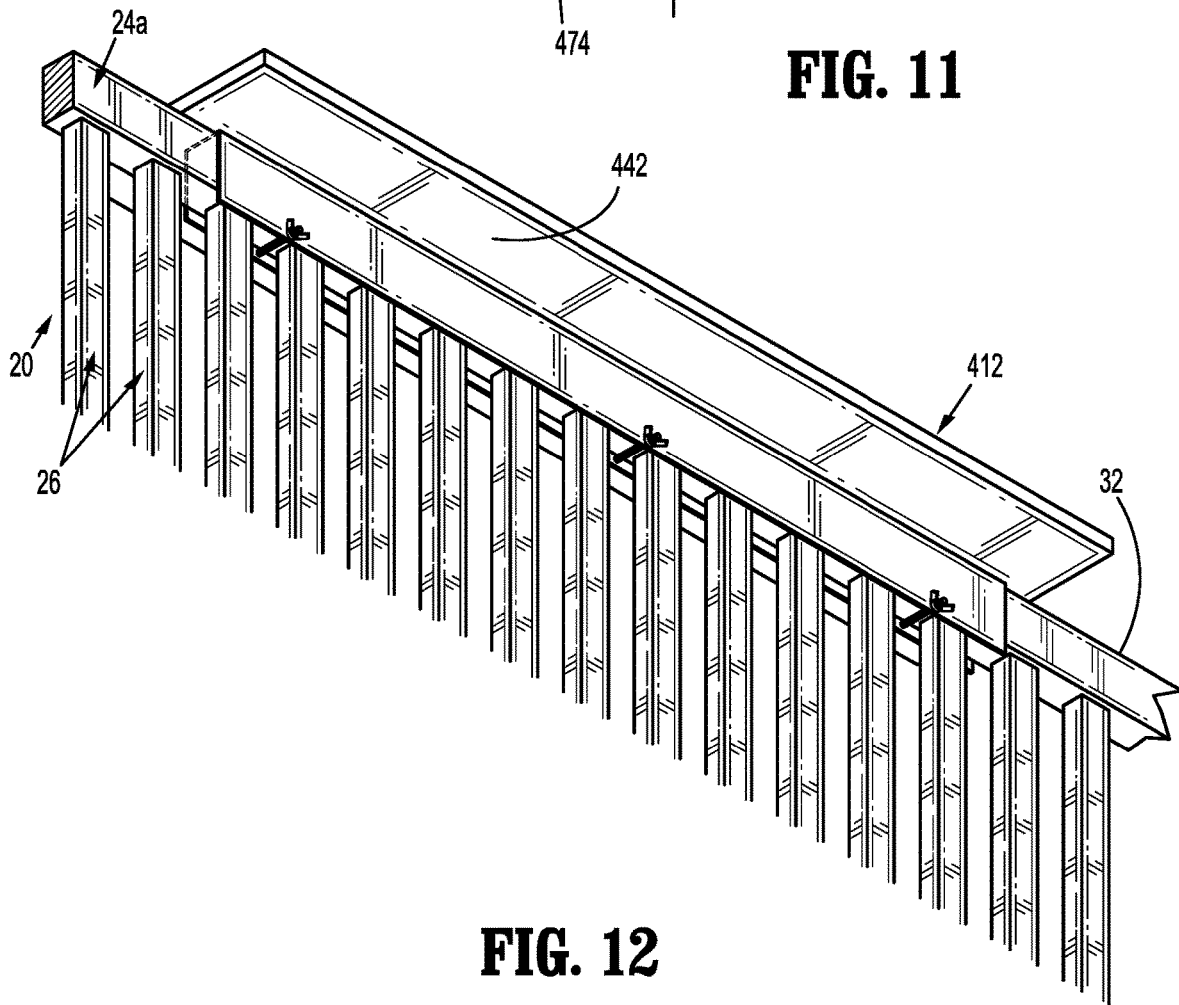

FIG. 12

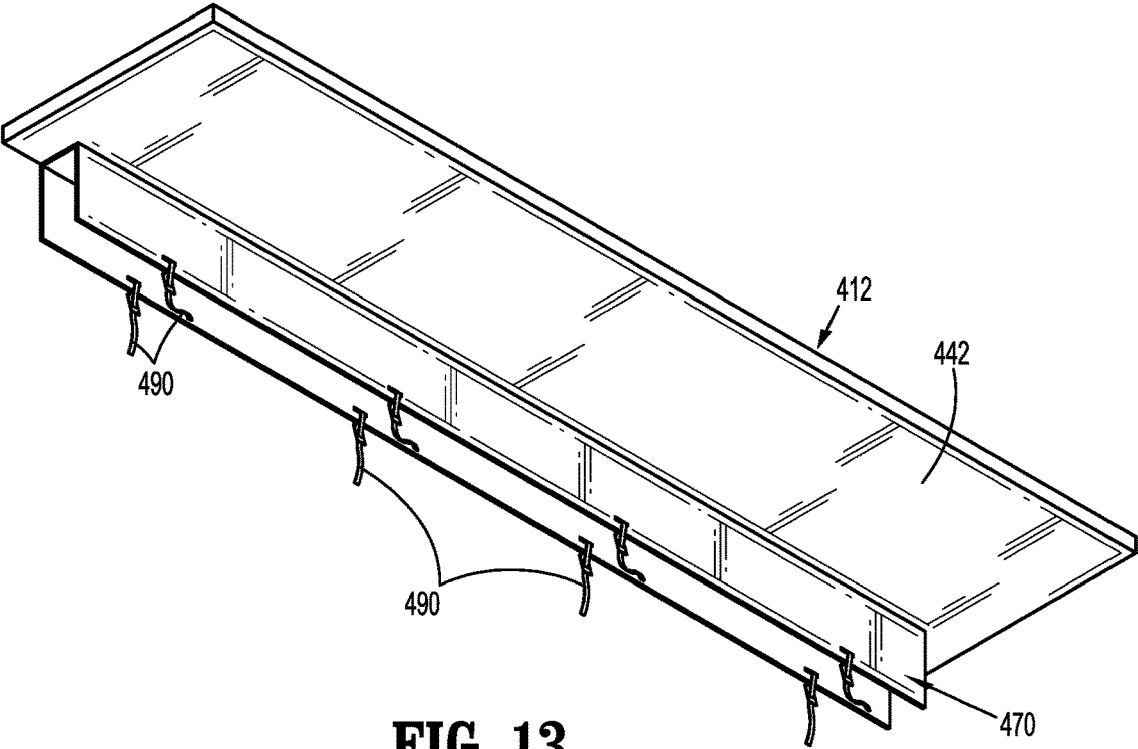

FIG. 13

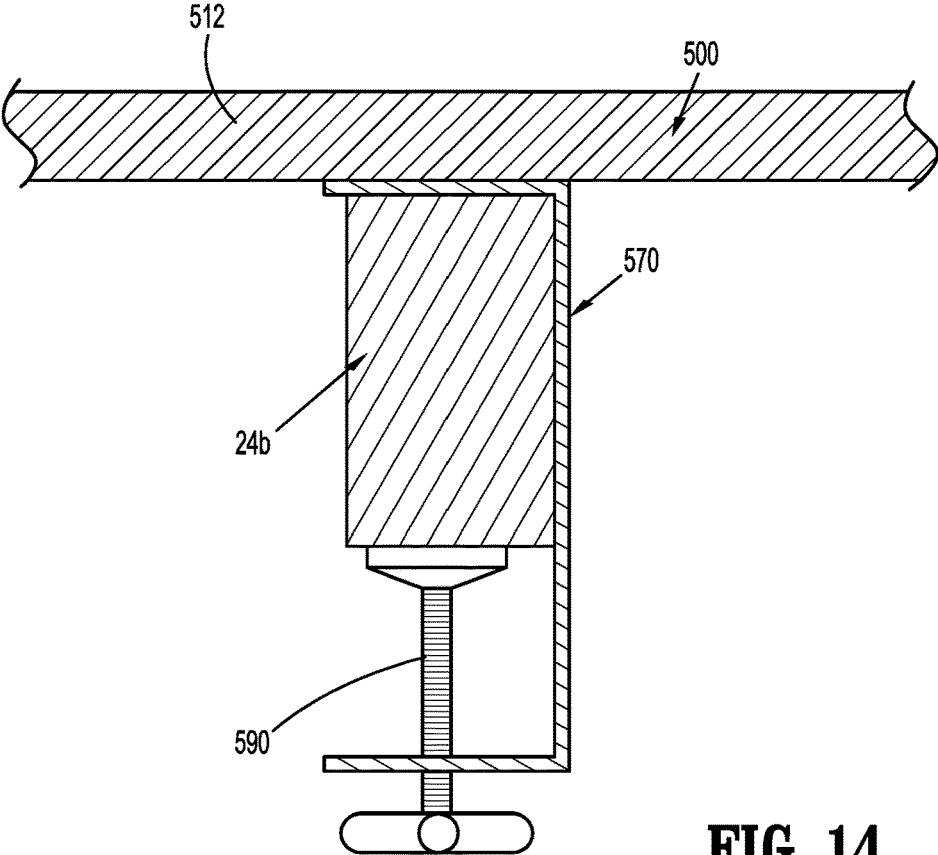

FIG. 14

TABLE TOP FENCE RAIL SYSTEM

CROSS-REFERENCE TO RELATED APPLICATIONS

[0001] This application is a divisional of U.S. patent application Ser. No. 16/290,298, filed Mar. 1, 2019, which claims the benefit of and priority to U.S. Provisional Patent Application Ser. No. 62/769,535, filed Nov. 19, 2018, and U.S. Provisional Patent Application Ser. No. 62/726,339, filed Feb. 3, 2018. The entire contents of each of the above disclosures is hereby incorporated by reference herein.

BACKGROUND

1. Technical Description

[0002] The present disclosure is directed to a system for incorporating a table top onto an existing fence and, more particularly, to a system for incorporating a table top onto an existing vinyl fence.

2. Background of Related Art

[0003] Vinyl fences for enclosing a specified area are well known. These fences are typically used to enclose yards, pools, boat docks, or the like to keep animals or children from entering or exiting the area. In such areas where socializing may be common, it is known to have tables separate from the existing fence to provide support for drinks, food, radios, or the like.

[0004] A continuing need exists in the art for an aesthetically pleasing table top that can make use of existing support structure of the fence and provide a more efficient use of existing space.

SUMMARY

[0005] One aspect of the disclosure is directed to a table top fence rail system that includes a fence, a table top, and a cap. The fence includes first and second posts, an upper horizontal rail extending between the first and second posts, a lower horizontal rail extending between the first and second posts, and a plurality of slats positioned between the posts. The upper horizontal rail defines an upper support surface, and the first and second posts have an upper end portion and a lower end portion. The table top includes a body having planar top and bottom surfaces. The body defines an opening that extends between the top and bottom planar surfaces and is dimensioned to receive the upper end portion of a respective one of the first and second posts. The cap is supported on the upper end portion of the respective one of the first and second posts and is dimensioned to retain the planar bottom surface of the body of the table top on the upper support surface of the upper horizontal rail of the fence.

[0006] In embodiments, the opening defined by the body of the table top and the respective one of the first and second posts are rectangular.

[0007] In some embodiments, the opening defined by the body of the table top is centrally positioned within the body of the table top.

[0008] In certain embodiments, the opening defined by the body of the table top is positioned along one side of the body of the table top.

[0009] In embodiments, the body of the table top has a rectangular configuration.

[0010] In some embodiments, the body of the table top has a circular configuration.

[0011] In certain embodiments, a sleeve positioned about the upper end portion of the respective one of the posts between the upper planar surface of the body of the table top and cap.

[0012] In embodiments, at least one of the sleeve and the cap is secured to the upper end portion of the respective one of the posts.

[0013] In some embodiments, the opening defined by the body of the table top is larger than the respective one of the posts, and the sleeve includes a lower extension that is received between the upper end portion of the respective one of the posts and the body of the table top to snugly position the table top on the upper end portion of the respective one of the posts.

[0014] In certain embodiments, the slats extend vertically between the upper and lower horizontal rails of the fence.

[0015] Another aspect of the disclosure is directed to a table top fence rail system that includes a fence, a table top, and a securing mechanism. The fence includes first and second posts, an upper horizontal rail extending between the first and second posts, a lower horizontal rail extending between the first and second posts, and a plurality of slats positioned between the posts. The upper horizontal rail defines an upper support surface, and the first and second posts have an upper end portion and a lower end portion. The table top includes a body having planar top and bottom surfaces and a bracket supported on the planar bottom surface of the body of the table top. The bracket has a U-shaped body that defines a U-shaped channel that is dimensioned to receive the upper horizontal rail of the fence. The securing mechanism is positioned beneath the upper horizontal rail to secure the table top to the upper horizontal rail.

[0016] In embodiments, the U-shaped body of the bracket includes first and second ends that extend beneath the upper horizontal rail when the table top is positioned on the upper support surface of the upper horizontal rail of the fence.

[0017] In some embodiments, the securing mechanism includes a bolt and a wing nut.

[0018] In certain embodiments, the securing mechanism includes hook and loop fasteners.

[0019] In embodiments, the securing mechanism includes a C-shaped body and the securing mechanism includes a threaded clamp.

[0020] Other features of the disclosure will be appreciated from the following description.

BRIEF DESCRIPTION OF THE DRAWINGS

[0021] Various embodiments of the presently disclosed kit are described herein below with reference to the drawings, wherein:

[0022] FIG. 1 is a side perspective view of an existing fence with an exemplary embodiment of the disclosed fence rail system including a center mounted rectangular table top supported on the fence;

[0023] FIG. 2 is a side perspective view of the fence and fence rail system with parts separated;

[0024] FIG. 3 is an enlarged view of the indicated area of detail shown in FIG. 1;

[0025] FIG. 4 is a side perspective view of another embodiment of the disclosed fence rail system including a side mounted rectangular table top supported on a fence;

[0026] FIG. 5 is a side perspective view of another embodiment of the disclosed fence rail system with a center mounted circular table top supported on the fence;

[0027] FIG. 6 is a top view of an adapter of the fence rail system shown in FIG. 1;

[0028] FIG. 7 is a side perspective view of the adapter shown in FIG. 6;

[0029] FIG. 8 is a side view of the adapter shown in FIG. 6;

[0030] FIG. 9 is a side cross-sectional view of the adapter and table top shown in FIG. 1 supported on the fence;

[0031] FIG. 10 is a side perspective view of another exemplary embodiment of the disclosed fence rail system including a rectangular table top supported on the fence;

[0032] FIG. 11 is a cross-sectional view taken along section line 11-11 of FIG. 10;

[0033] FIG. 12 is a view from the bottom of the fence rail system shown in FIG. 10;

[0034] FIG. 13 is a bottom perspective view of another exemplary embodiment of the disclosed fence rail system including a rectangular table top supported on the fence; and

[0035] FIG. 14 FIG. 10 is a cross-sectional view of another exemplary embodiment of the disclosed fence rail system including a table top supported on the fence.

DETAILED DESCRIPTION OF EMBODIMENTS

[0036] Exemplary embodiments of the disclosed table top fence rail system will now be described in detail with reference to the drawings in which like reference numerals designate identical or corresponding elements in each of the several views. However, it is to be understood that the disclosed embodiments are merely exemplary of the disclosure and may be embodied in various forms. Well-known functions or constructions are not described in detail to avoid obscuring the present disclosure in unnecessary detail. Therefore, specific structural and functional details disclosed herein are not to be interpreted as limiting, but merely as a basis for the claims and as a representative basis for teaching one skilled in the art to variously employ the present disclosure in virtually any appropriately detailed structure. In addition, directional terms such as front, rear, upper, lower, top, bottom, distal, proximal, and similar terms are used to assist in understanding the description and are not intended to limit the present disclosure.

[0037] FIGS. 1-3 illustrate an exemplary embodiment of the disclosed fence rail system shown generally as 10. The fence rail system 10 includes a table top 12 and a sleeve 14 that are mounted onto a new or existing fence 20. The fence 20 includes spaced posts 22, upper and lower horizontal rails 24a, 24b, and a plurality of slats 26. The slats 26, although illustrated as being vertical, can be mounted in any desirable orientation. The posts 22 have a lower end 22a supported in the ground or in another support surface and an upper end 22b that supports a cap 30. The upper and lower horizontal rails 24a, 24b extend between the posts 22. In embodiments, the upper horizontal rail 24b includes a flat upper support surface 32 although other configurations are envisioned. The vertical slats 26 are supported between the upper and lower horizontal rails 24a, 24b and provide stability to the fence 20.

[0038] The table top 12 includes planar upper and lower surfaces 40, 42 respectively. The upper surface 40 of the table top 12 is configured to support objects such as plates, glasses, speakers, or the like. The lower surface 42 of the

table top 12 is configured to rest atop the flat upper support surface 32 of the upper horizontal rail 24a to stabilize the table top on the fence 20. The table top 12 defines a central opening 44 (FIG. 2) that is dimensioned to receive the upper end 22b of the post 22.

[0039] The sleeve 14 includes an inner bore 14a that is dimensioned to receive the upper end 22b of the post 22. The inner bore 14a should be dimensioned to snugly receive the upper end 22b of the post 22 so that the sleeve 14 frictionally engage the outer surface of the post 22 to a degree to be retained in a fixed vertical position on the post 22. When the sleeve 14 is pressed downwardly onto the post 22 into engagement with the planar upper surface 40 of the table top 12, the sleeve 12 will provide a force on the upper planar surface 40 of the table top 12 to hold the table top 12 against the flat upper surface 32 of the upper horizontal rail 24a and provide stability to the table top 12.

[0040] In use of the fence rail system 10, the cap 30 is removed from the upper end 22b of the post 22 and the table top 12 is placed on the flat upper surface 32 of the upper horizontal rail 24a such that the upper end 22b of the post 22 is received through the opening 44 in the table top 12. Although only a single opening 44 is shown in the table top 12 in FIG. 2, it is envisioned that a table top 12 that has a length greater than the distance between two adjacent posts 22 may include two openings 44 to receive the two adjacent posts 22.

[0041] After the table top 12 is supported on the flat upper surface 32 of the upper rail 24a, the sleeve 14 can be positioned on the upper end 22b of the post 22 to press the table top 12 against the upper rail 24a. This will provide stability to the table top 12 on the flat surface 32 of the upper rail 24a. In embodiments, the sleeve 14 may have a decorative configuration to make the table top fence rail system 10 more aesthetically pleasing. The cap 30 can be replaced on the upper end 22b of the post 22 to secure the sleeve 14 on the post 22 against the upper planar surface 40 of the table top 12. In embodiments, the sleeve 14 and/or the cap 30 can be fixedly secured to the upper end 22b of the post 22 to provide more stability to the table top 12. For example, the sleeve 14 and/or the cap 30 may be glued or bolted to the upper end 22b of the post 22.

[0042] FIG. 4 illustrates another exemplary embodiment of the disclosed fence rail system shown generally as fence rail system 100. The fence rail system 100 is substantially identical to the fence rail system 10 except that the opening 144 formed in the table top 112 is positioned on one side of the table top 112 rather than at a central location within the table top 112. In this system, one side of the table top 12 is supported on the flat upper surface 32 of the upper rail 24a of the fence 20. This provides for a table top 112 that extends to one side of the fence 20 rather than to both sides of the fence 20.

[0043] FIG. 5 illustrates another exemplary embodiment of the disclosed fence rail system shown generally as fence rail system 200. The fence rail system 200 is substantially identical to the fence rail system 10 shown in FIG. 1 except that the table top 212 is circular rather than rectangular. In this embodiment, the table top 212 defines an opening 244 in a central portion of the table top 212 that is dimensioned to receive the post 22 of the fence 20. Although only rectangular and circular table tops 12, 112, and 212 are

illustrated in this application, it is envisioned that the table top may assume any desired configuration in accordance with this disclosure.

[0044] FIGS. 6-9 illustrate an alternative embodiment of the sleeve 314 of the fence rail system which functions as an adapter. In some embodiments, the hole 344 (FIG. 9) in the table top 312 may be sized to receive a post 22 of a fence 20 that has a first width "A" (FIG. 6), e.g., a 5 inch width, but the post 22 may have a second smaller width "B" (FIG. 6), e.g., a 4 inch width. It is noted that standard size posts in vinyl fencing have 4 and 5 inch widths. Where the width of the hole 344 (FIG. 9) in the table top 312 is larger than the width of the post 22, the sleeve 314 may include a lower extension 360 that has an opening 344a that is dimensioned to receive the smaller post 22 and an outer surface 344b that is dimensioned to be snugly received within the opening 344 of the table top 312 in a friction fit manner. When the sleeve 314 is positioned about the upper end 22b of the post 22, the lower extension 360 is positioned between the post 22 and the table top 312 such that the table top 312 is stabilized on the post 22. This allows table tops 312 to be used with fence posts 22 of different sizes.

[0045] FIGS. 10 and 11 illustrate an alternate embodiment of the disclosed fence rail system shown generally as 400. The fence rail system 400 differs from the fence rail systems disclosed above in that the table top 412 does not have an opening to receive a fence post 22. In contrast, the fence rail system 400 includes a lower bracket 470 that defines a U-shaped channel 472 and extends downwardly from a bottom surface 442 of the table top 412. The channel 472 has a depth to receive the upper rail 24a of the fence 20 such that ends 470a of the lower bracket 470 extend below the upper rail 24a. The bracket 470 supports a securing mechanism such as bolts 474 that extend between the ends of the bracket 470 at a location beneath the upper rail 24a of the fence 20. When the table top 412 is positioned on the flat upper surface 32 of the upper rail 24a, the bolts 474 extend below the upper rail 24a to secure the table top 412 to the upper rail 24a of the fence 20.

[0046] In embodiments, the bracket 470 can be secured to the bottom surface of the table top 412 using any known fastening technique including screws, bolts, welding or the like. The bolts 474 can be secured between opposite sides of the lower bracket 470 using threaded wing nuts 478 (FIG. 11). Alternately other securement mechanisms or techniques can be used to secure the bracket 470 to the upper rail 24b of the fence 20. For example, as shown in FIG. 13, straps 490 having hooked and loop fasteners can be used to secure the bracket 470 to the upper rail 24a of the fence 20.

[0047] FIG. 14 illustrates another exemplary embodiment of the disclosed fence rail system shown generally as fence rail system 500. The fence rail system 500 is substantially identical to the fence rail system 400 except that the bracket 570 is C-shaped and includes a threaded clamp 590 to secure the bracket 570 to the upper rail 24b of the fence 20. It is envisioned that the brackets 470 and 570 may be used with the table tops including a central opening that receives a post 22 of the fence 20 to provide greater stability to the table tops after the table tops are secured to the fence 20.

[0048] It is envisioned that the table tops, sleeves, and/or brackets can be provided as part of a kit to facilitate attachment of a table top to an existing fence such as a vinyl fence. However, it is envisioned that the present system can be used with a variety of fence types. The presently dis-

closed kit would include at least one table top 12, 112, 212, 312, 412 and/or 512, one or more sleeves 14, 314, and additional caps 30. During installation of the table tops 12, 112, 212 onto an existing or new fence 20, the cap 30 can be removed from the upper end portion 22b of a post 22 fence 20 and one of the table tops can be positioned about the upper end of the post 22b and secured in place as described above. The table tops 412 and 512 can also be secured to a fence 20 in the manner described above.

[0049] Persons skilled in the art will understand that the devices and methods specifically described herein and illustrated in the accompanying drawings are non-limiting exemplary embodiments. For example, although the slats are shown to run vertically between the upper and lower rails, it is envisioned that the slats may run horizontally between the posts. It is also envisioned that the horizontal slats may be similar in configuration to the upper and lower rails. It is envisioned that the elements and features illustrated or described in connection with one exemplary embodiment may be combined with the elements and features of another without departing from the scope of the present disclosure. As well, one skilled in the art will appreciate further features and advantages of the disclosure based on the above-described embodiments. Accordingly, the disclosure is not to be limited by what has been particularly shown and described, except as indicated by the appended claims.

What is claimed is:

1. A table top fence rail system comprising:
 - a fence including first and second posts, an upper horizontal rail extending between the first and second posts, a lower horizontal rail extending between the first and second posts, and a plurality of slats positioned between the posts, the upper horizontal rail defining an upper support surface, and the first and second posts having an upper end portion and a lower end portion;
 - a table top including a body having planar top and bottom surfaces, the body defining an opening that extends between the top and bottom planar surfaces of the body of the table top, the opening being dimensioned to receive the upper end portion of a respective one of the first and second posts; and
 - a cap supported on the upper end portion of the respective one of the first and second posts, the cap being dimensioned to retain the planar bottom surface of the body of the table top on the upper support surface of the upper horizontal rail of the fence.
2. The table top fence rail system of claim 1, wherein the opening defined by the body of the table top and the respective one of the first and second posts are rectangular.
3. The table top fence rail system of claim 1, wherein the opening defined by the body of the table top is centrally positioned within the body of the table top.
4. The table top fence rail system of claim 1, wherein the opening defined by the body of the table top is positioned along one side of the body of the table top.
5. The table top fence rail system of claim 1, wherein the body of the table top has a rectangular configuration
6. The table top fence rail system of claim 1, wherein the body of the table top has a circular configuration.
7. The table top fence rail system of claim 1, further including a sleeve positioned about the upper end portion of the respective one of the posts between the upper planar surface of the body of the table top and cap.

8. The table top fence rail system of claim 1, wherein at least one of the sleeve and the cap are secured to the upper end portion of the respective one of the posts.

9. The table top fence rail system of claim 7, wherein the opening defined by the body of the table top is larger than the respective one of the posts, and the sleeve includes a lower extension that is received between the upper end portion of the respective one of the posts and the body of the table top to snugly position the table top on the upper end portion of the respective one of the posts.

10. The table top fence rail system of claim 1, wherein the slats extend vertically between the upper and lower horizontal rails of the fence.

11. A table top fence rail system comprising:

a fence including first and second posts, an upper horizontal rail extending between the first and second posts, a lower horizontal rail extending between the first and second posts, and a plurality of slats positioned between the posts, the upper horizontal rail defining an upper support surface, and the first and second posts having an upper end portion and a lower end portion;

a table top including a body having planar top and bottom surfaces, the table top having a bracket supported on the planar bottom surface of the table top, the bracket having a U-shaped body, the U-shaped body defining a U-shaped channel that is dimensioned to receive the upper horizontal rail; and

a securing mechanism positioned beneath the upper horizontal rail to secure the table top to the upper horizontal rail.

12. The table top fence rail system of claim 11, wherein the U-shaped body of the bracket includes first and second ends that extend beneath the upper horizontal rail when the table top is secured to the fence.

13. The table top fence rail system of claim 12, wherein the securing mechanism includes a bolt and a wing nut.

14. The table top fence rail system of claim 12, wherein the securing mechanism includes hook and loop fasteners.

15. The table top fence rail system of claim 11, wherein the securing mechanism includes a C-shaped body and the securing mechanism includes a threaded clamp.

* * * * *