



US 20220063740A1

(19) **United States**

(12) **Patent Application Publication**

Boily et al.

(10) **Pub. No.: US 2022/0063740 A1**

(43) **Pub. Date: Mar. 3, 2022**

(54) **TRACK SYSTEM FOR TRACTION OF A VEHICLE**

B60K 28/10 (2006.01)

B60K 35/00 (2006.01)

G07C 5/08 (2006.01)

(71) Applicant: **CAMSO INC.**, Magog (CA)

(52) **U.S. Cl.**

(72) Inventors: **Patrice Boily**, Ste-Catherine-de-Hatley (CA); **Matthieu Bergeron**, Sherbrooke (CA); **Simon Richard**, Sherbrooke (CA); **Ghislain Laperle**, Sherbrooke (CA)

CPC *B62D 55/244* (2013.01); *B29D 29/00* (2013.01); *B60K 28/10* (2013.01); *B29L 2029/00* (2013.01); *G07C 5/0808* (2013.01); *G07C 5/0825* (2013.01); *B29K 2995/0087* (2013.01); *B60K 35/00* (2013.01)

(21) Appl. No.: **17/521,799**

(57) **ABSTRACT**

(22) Filed: **Nov. 8, 2021**

A track for traction of a vehicle, such as an agricultural vehicle, an industrial vehicle (e.g., a construction vehicle), a military vehicle, or another off-road vehicle, is provided. The track comprises a ground-engaging outer surface for engaging the ground and a plurality of traction projections projecting from the ground-engaging outer surface and distributed in a longitudinal direction of the track. The traction projections may be designed to enhance their resistance to deterioration during use. For example, a blowout resistance of each traction projection may be enhanced to prevent or at least reduce a potential for blowout of the traction projection under repeated loads which may induce heat buildup within it. Also, a wear resistance of the traction projection may be enhanced such that the traction projection wears less rapidly. A system for protecting a track against potential occurrence of blowout is also provided.

Related U.S. Application Data

(63) Continuation of application No. 15/555,148, filed on Sep. 1, 2017, now Pat. No. 11,167,810, filed as application No. PCT/CA2016/050234 on Mar. 4, 2016.

(60) Provisional application No. 62/128,183, filed on Mar. 4, 2015.

Publication Classification

(51) **Int. Cl.**

B62D 55/24 (2006.01)

B29D 29/00 (2006.01)

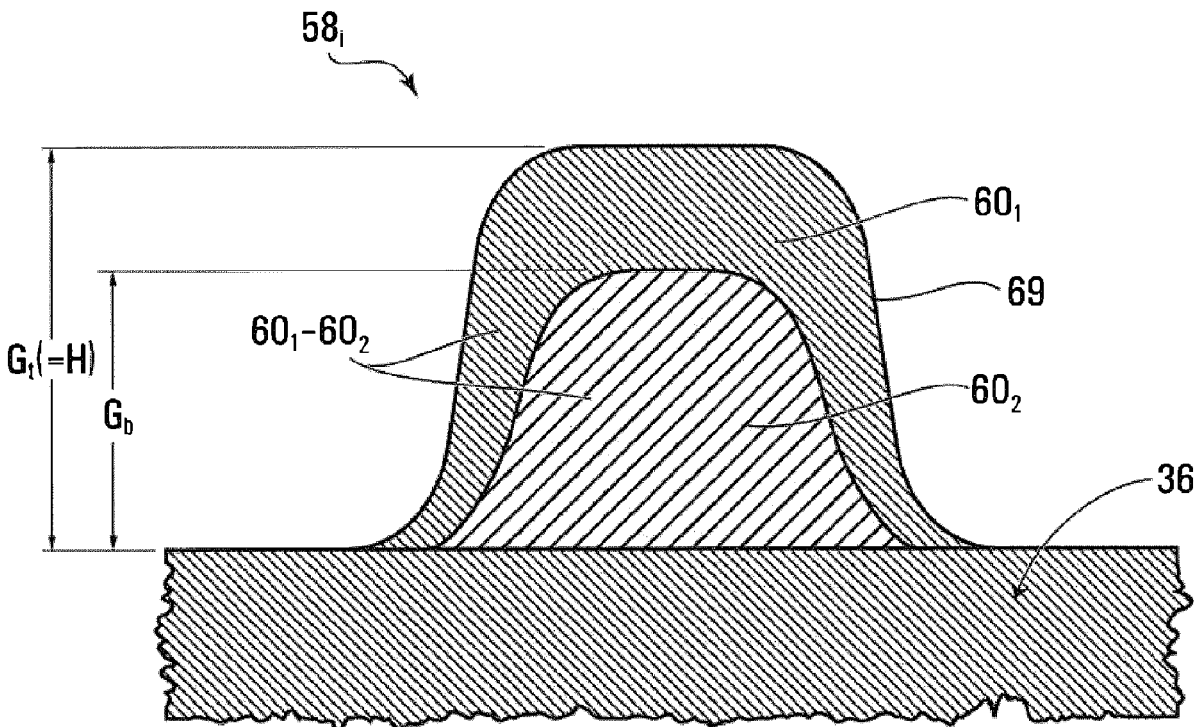

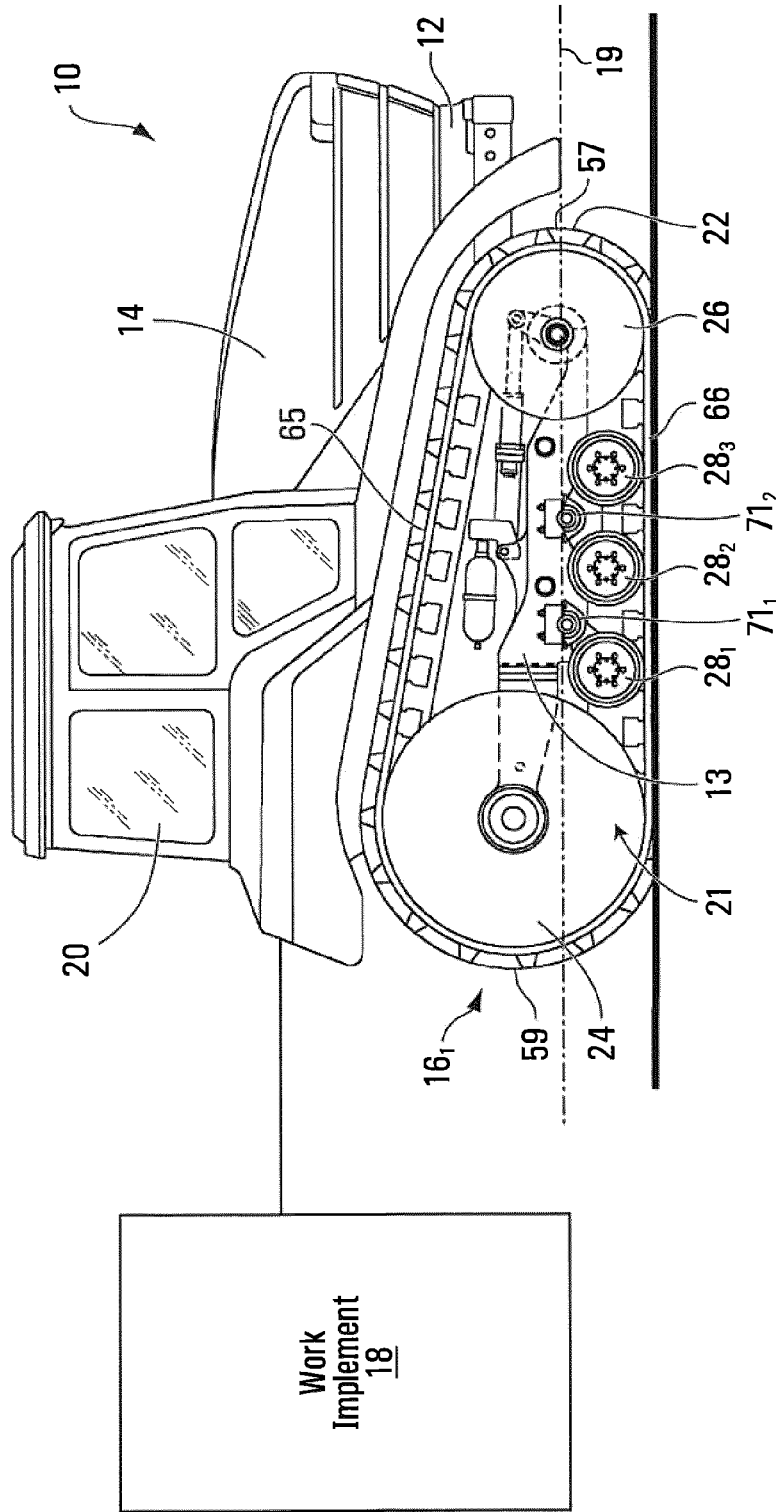

FIG. 1

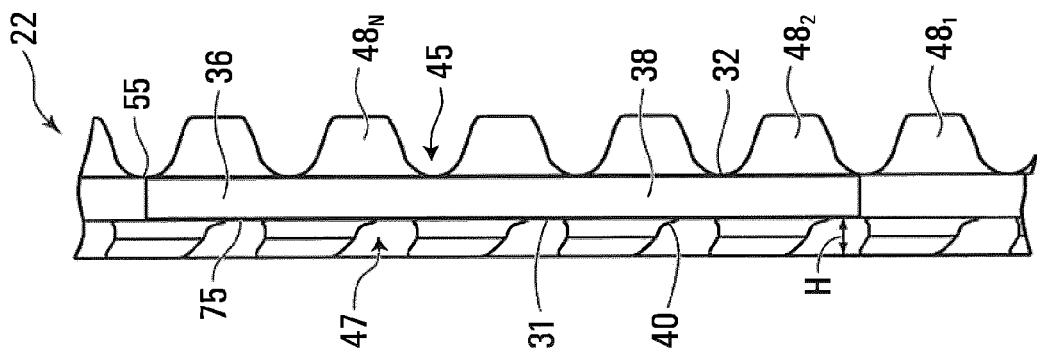

FIG. 3

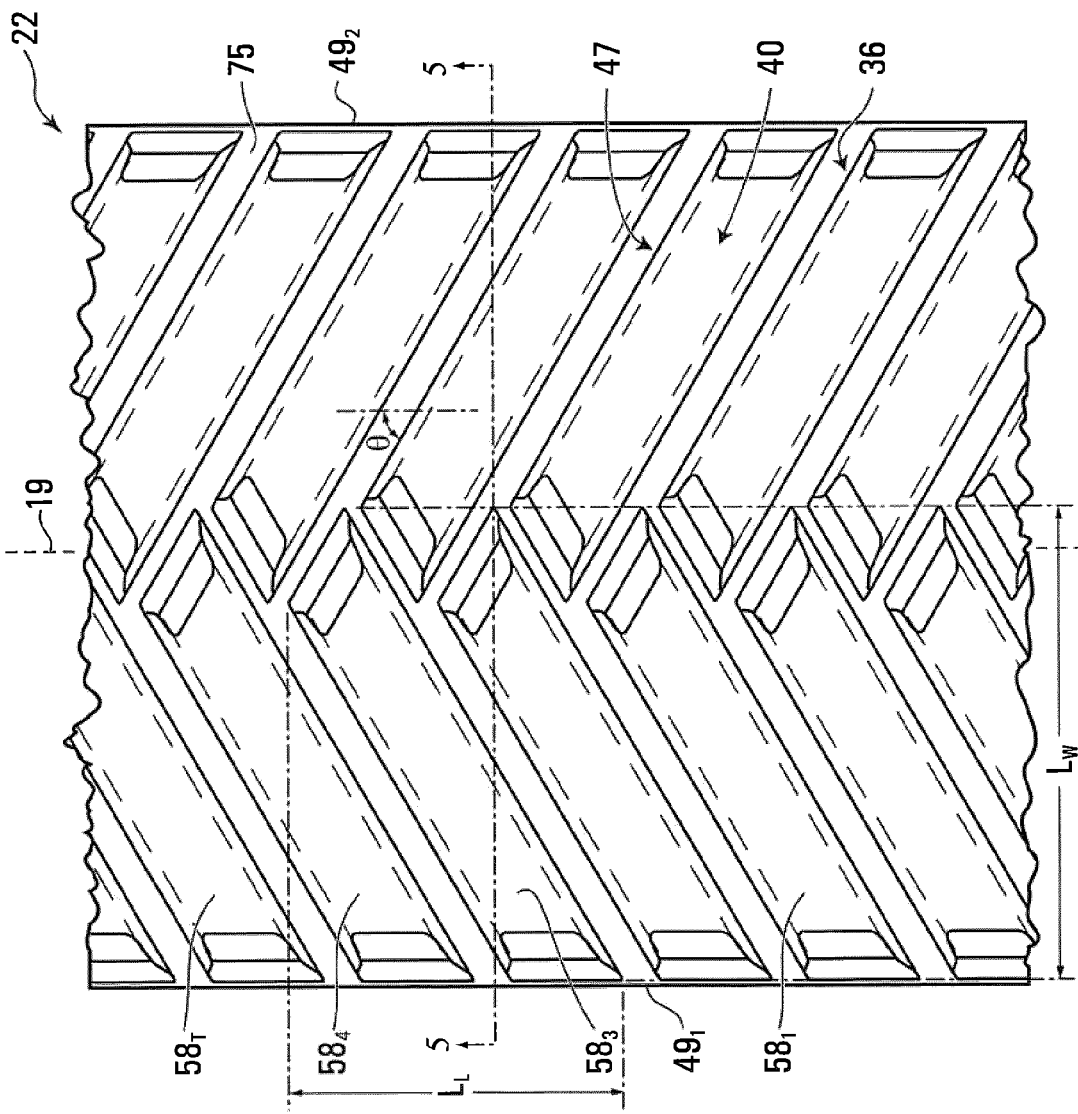

FIG. 2

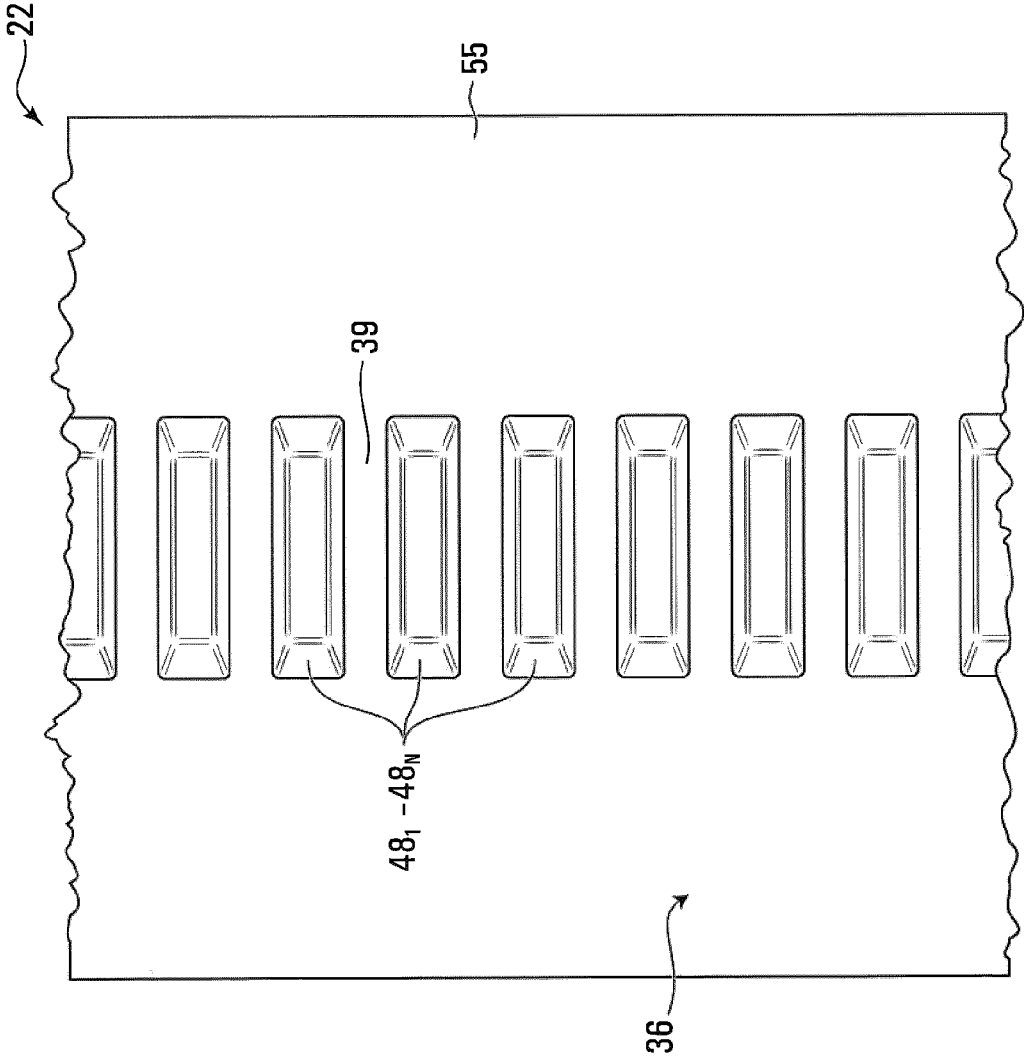

FIG. 4

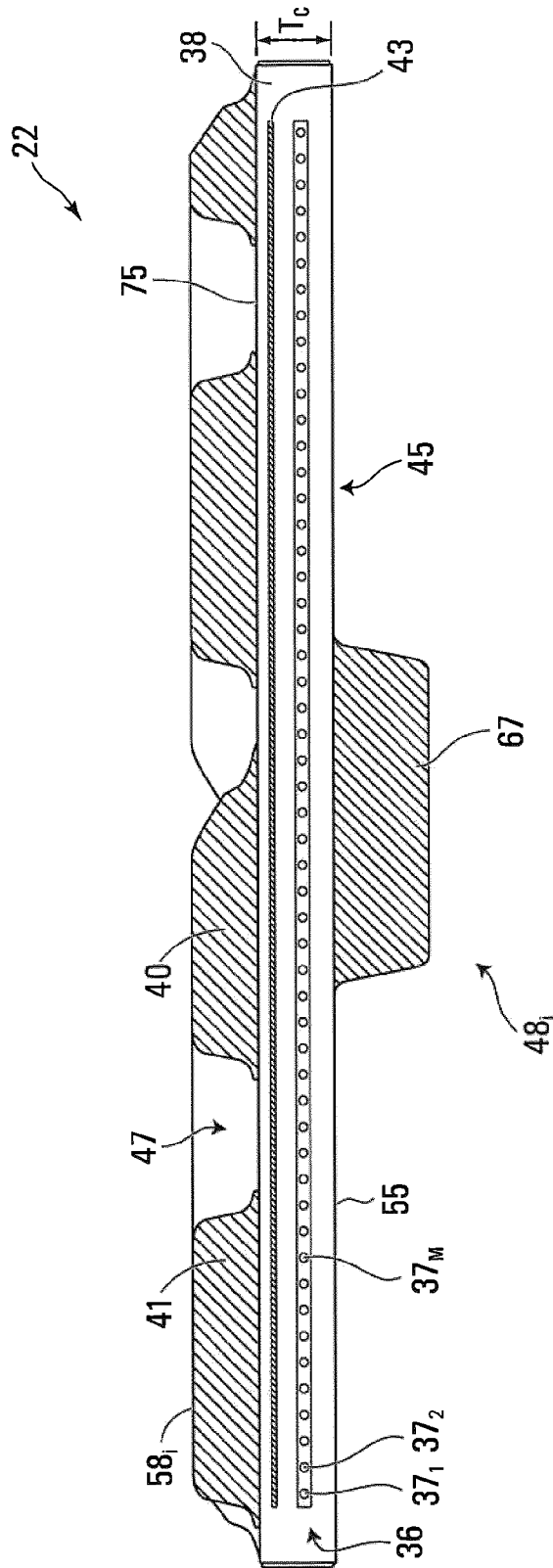

FIG. 5

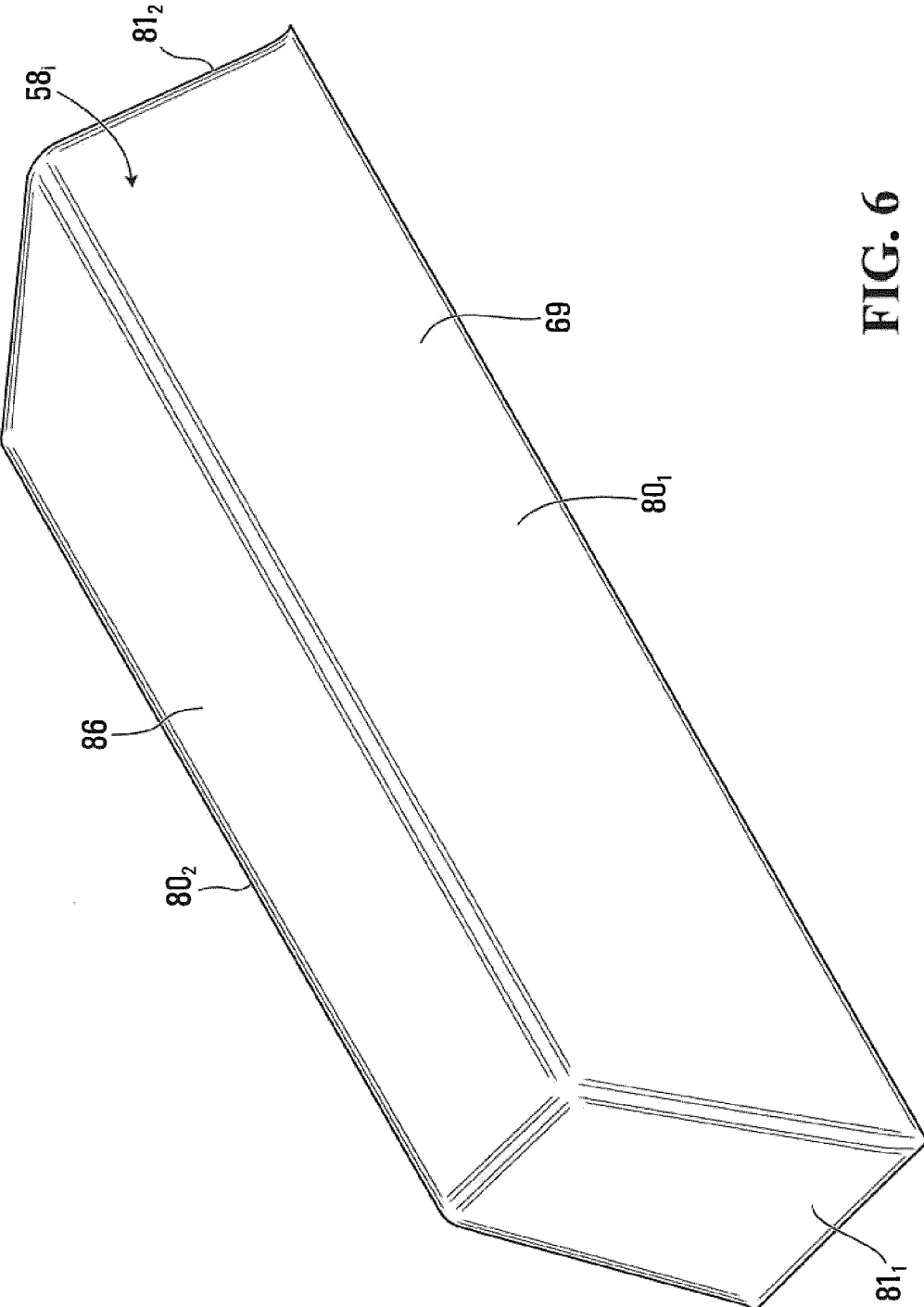

FIG. 6

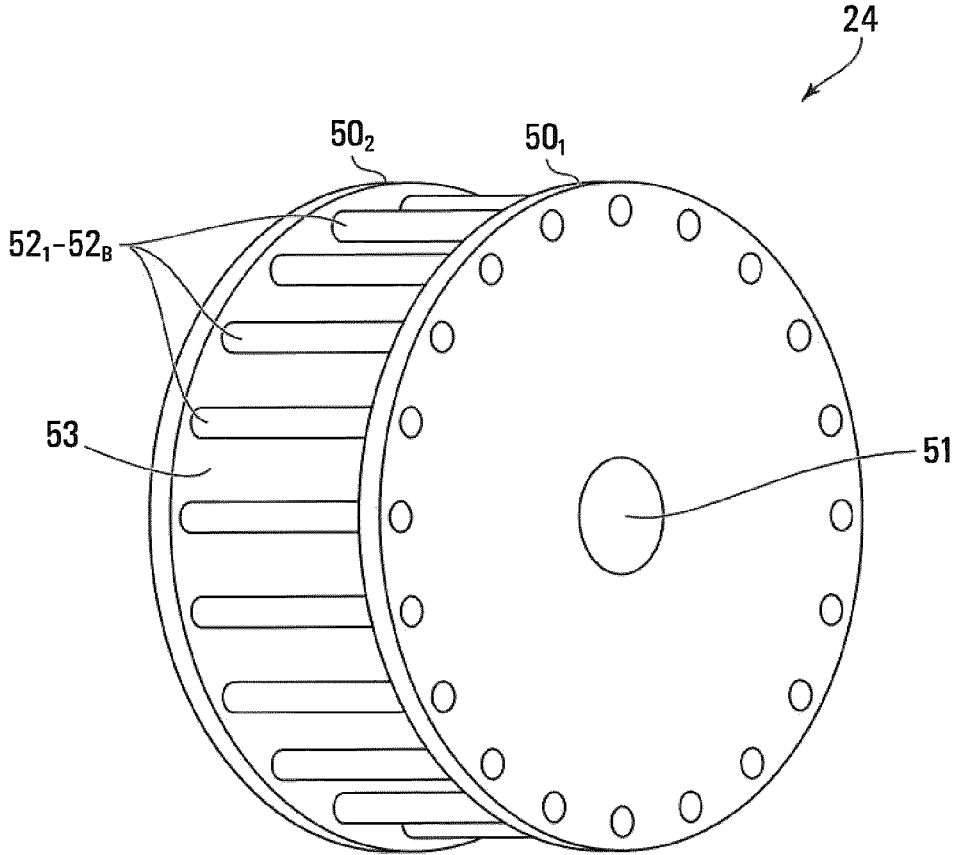

FIG. 7

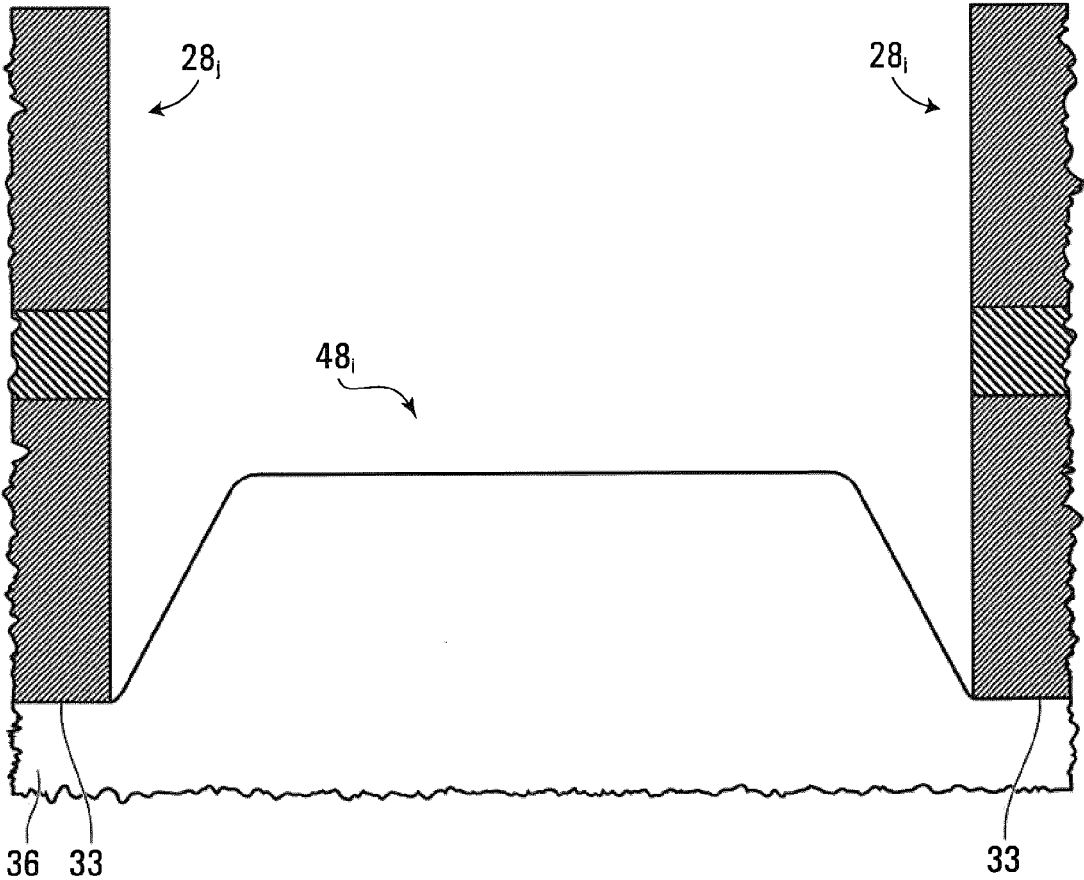

FIG. 8

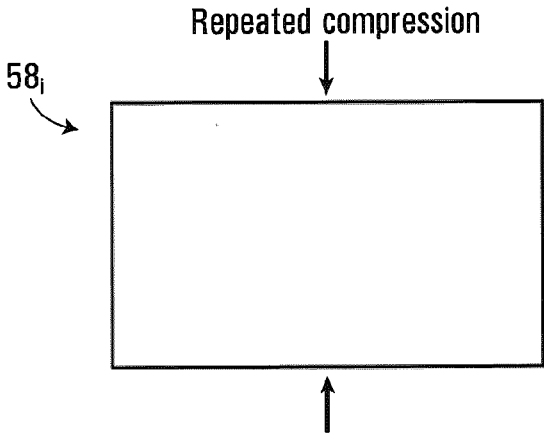

FIG. 9

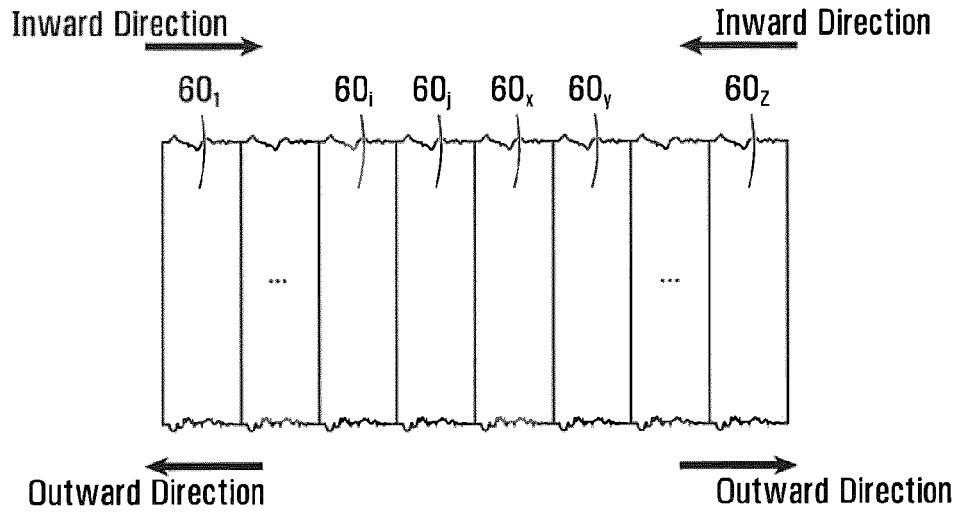

FIG. 10

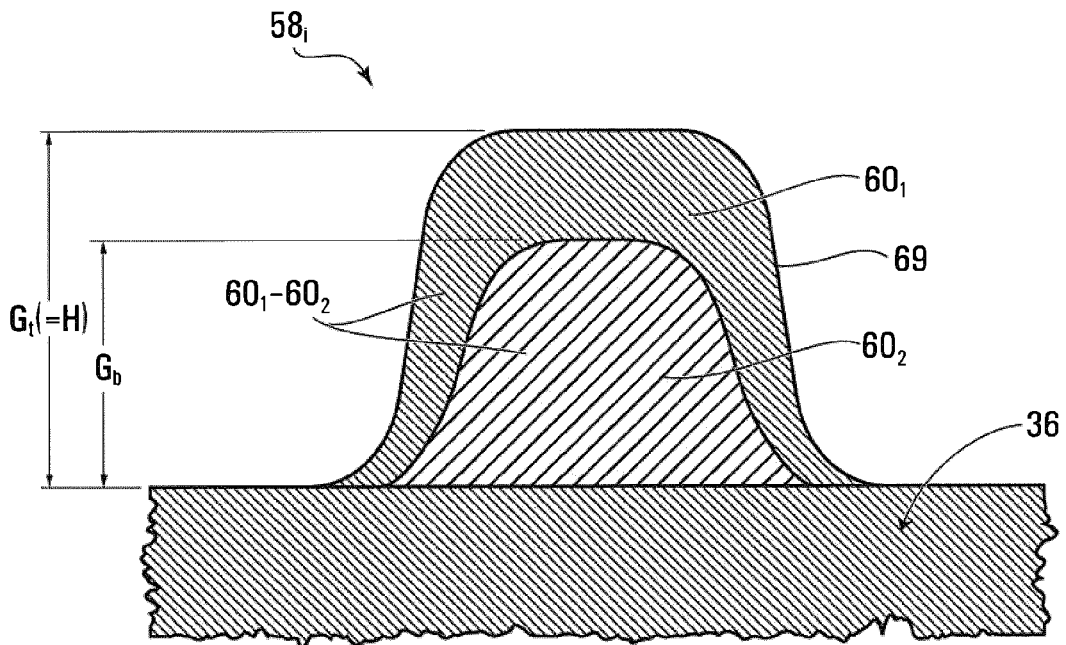

FIG. 11

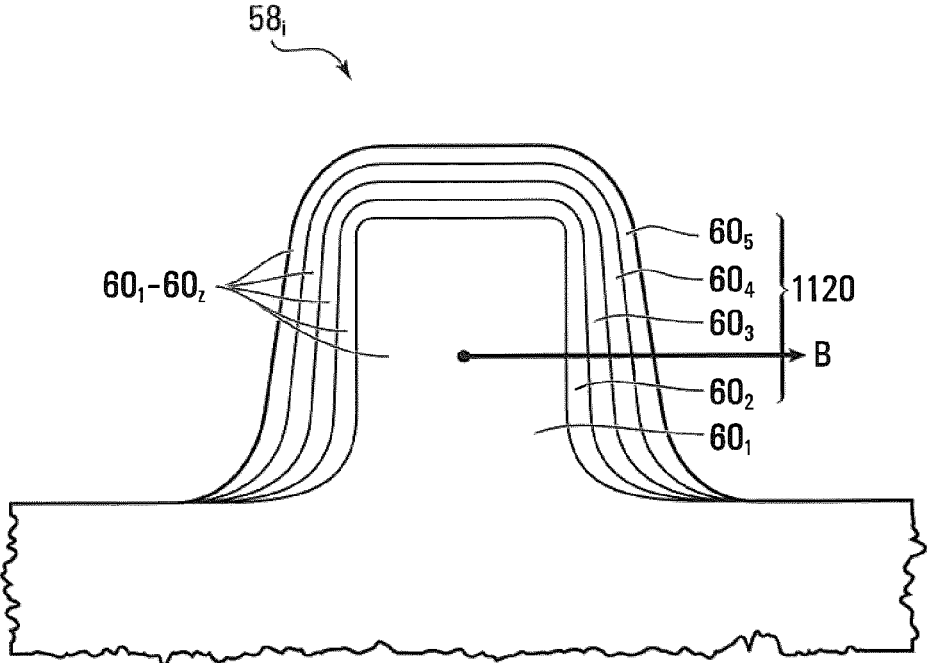

FIG. 12

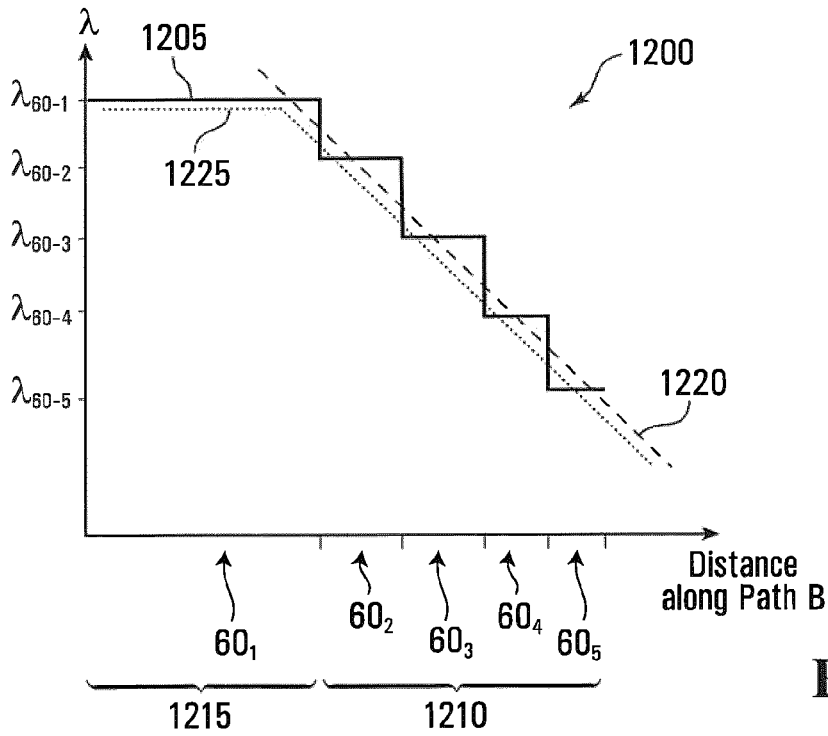

FIG. 13A

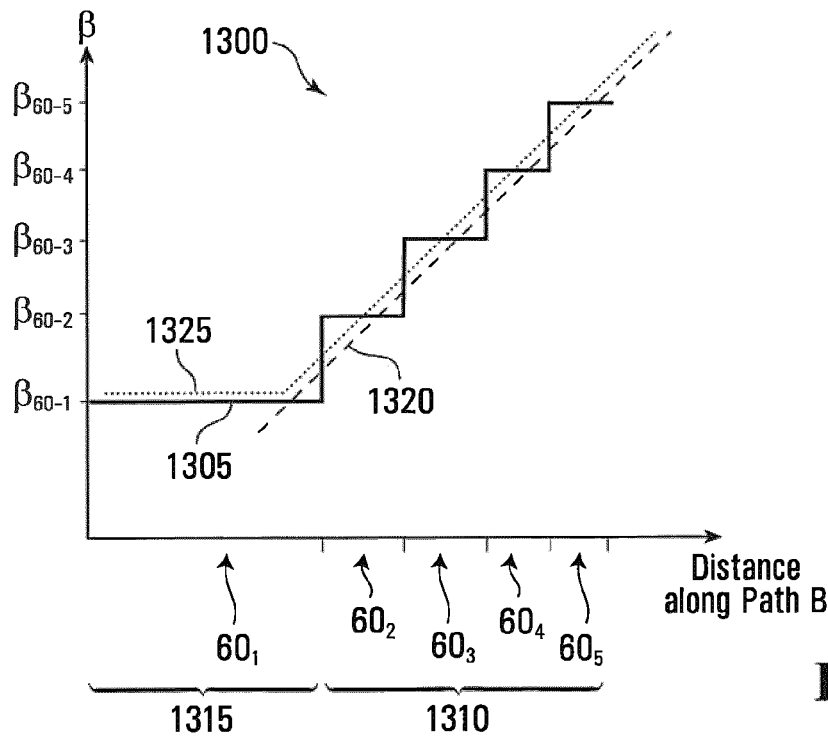

FIG. 13B

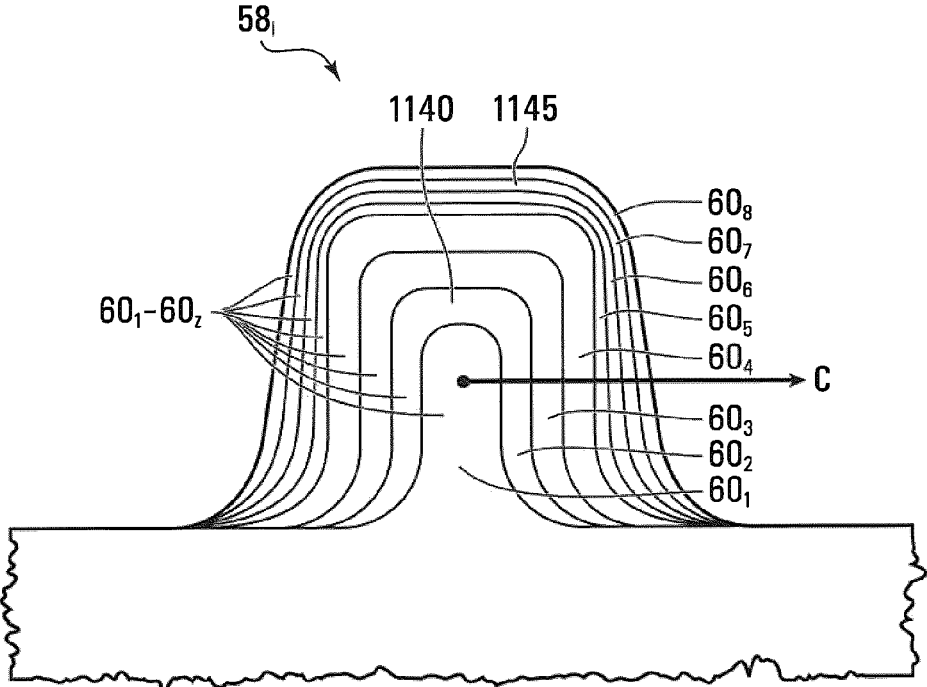

FIG. 14

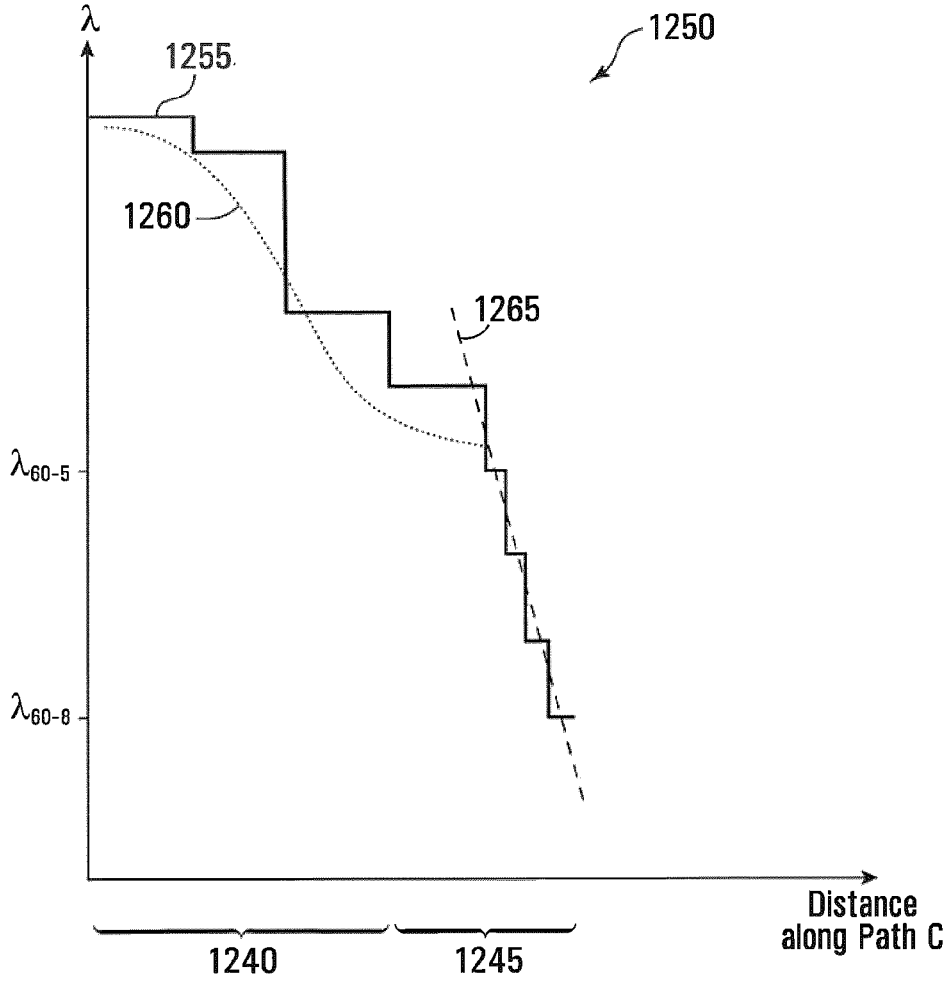

FIG. 15A

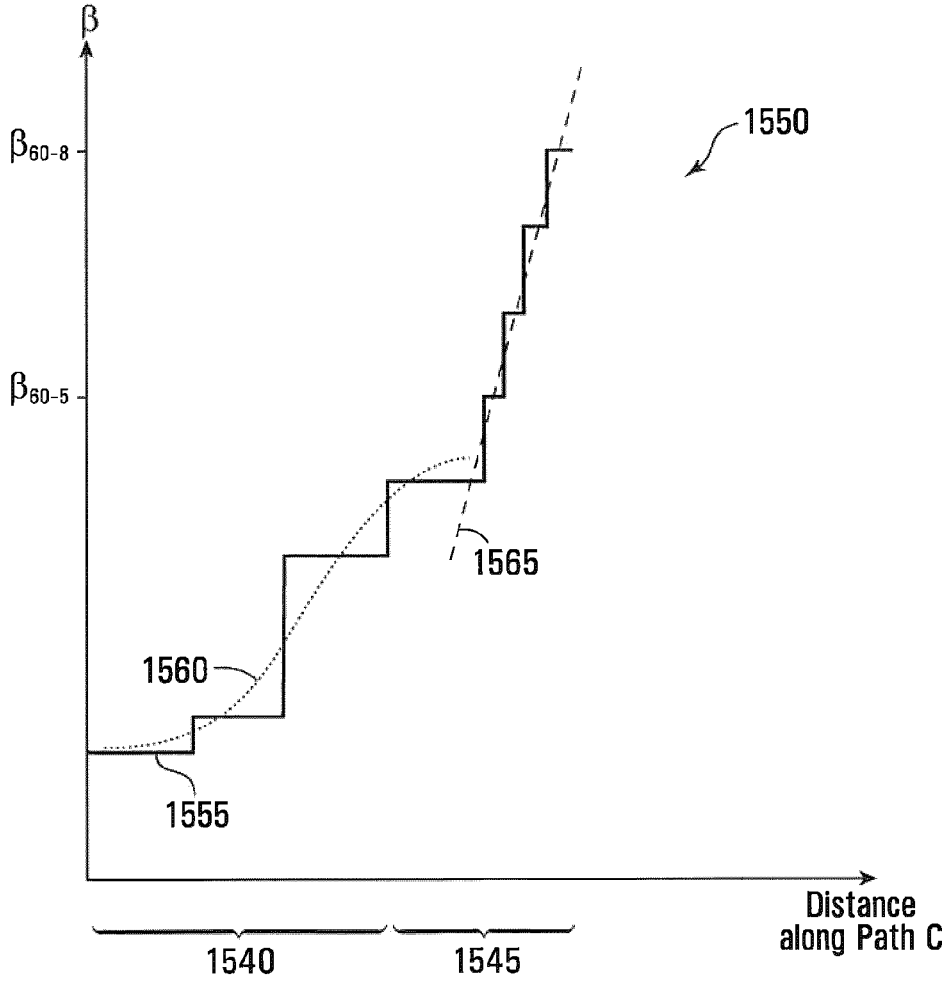

FIG. 15B

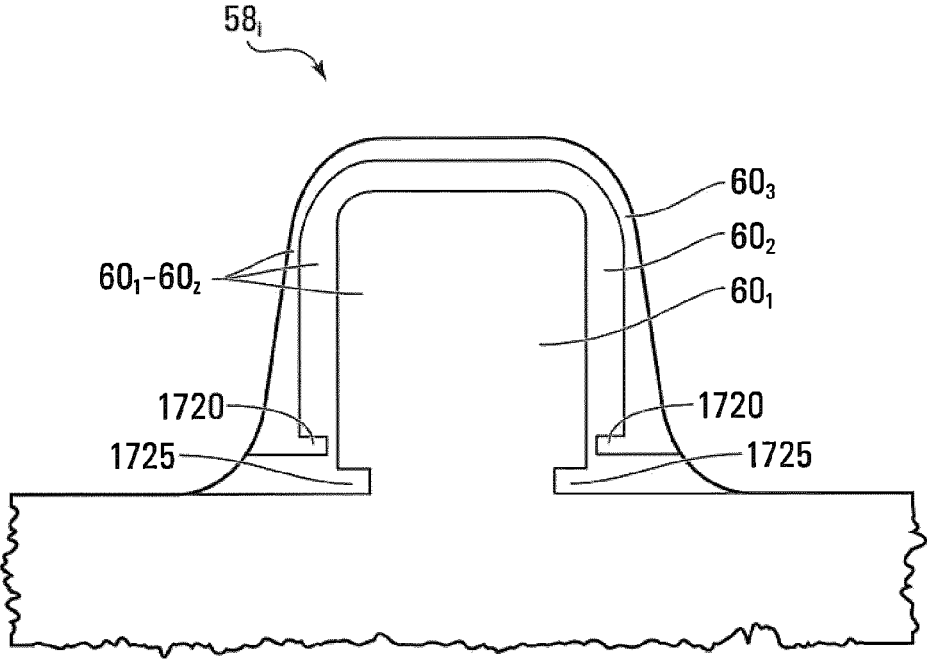

FIG. 16

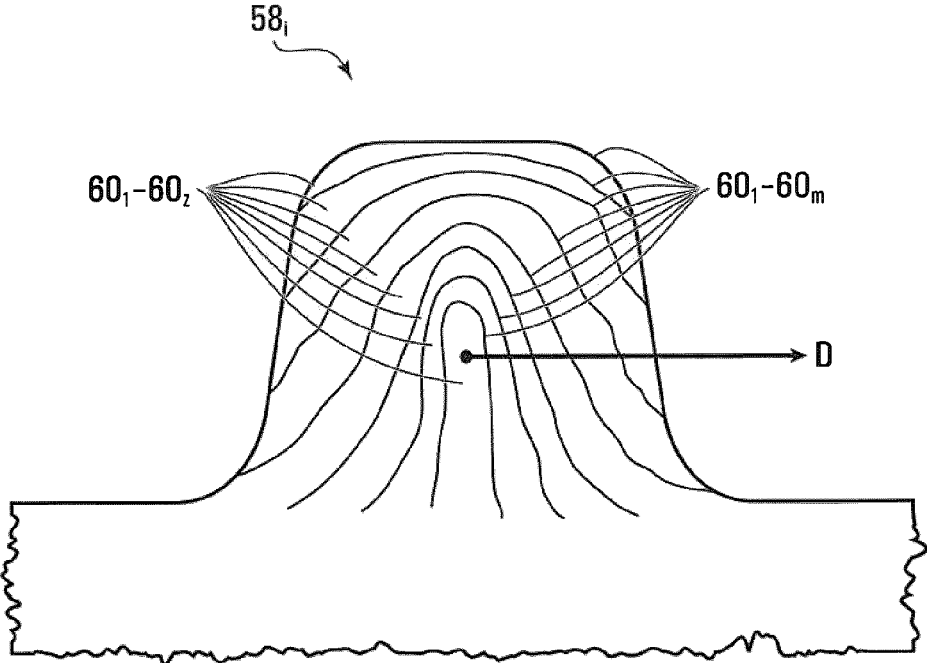

FIG. 17

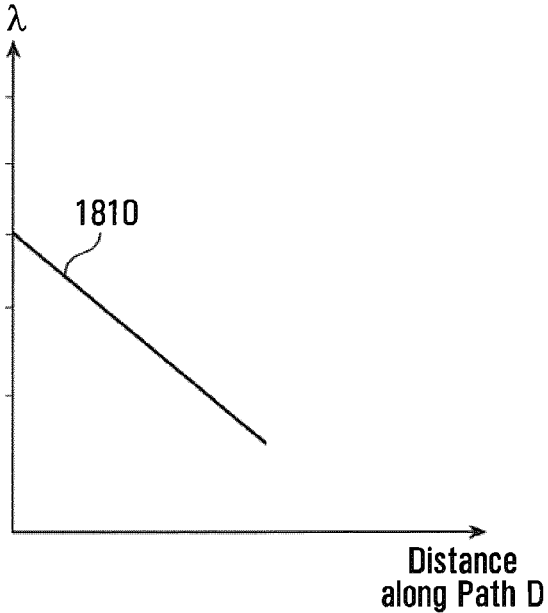

FIG. 18A

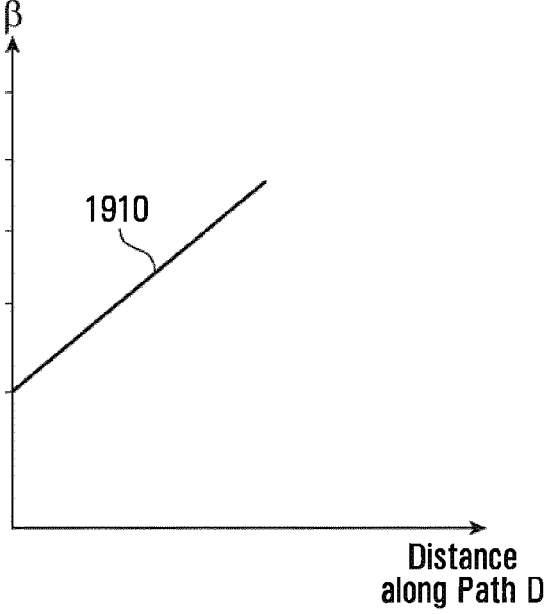

FIG. 18B

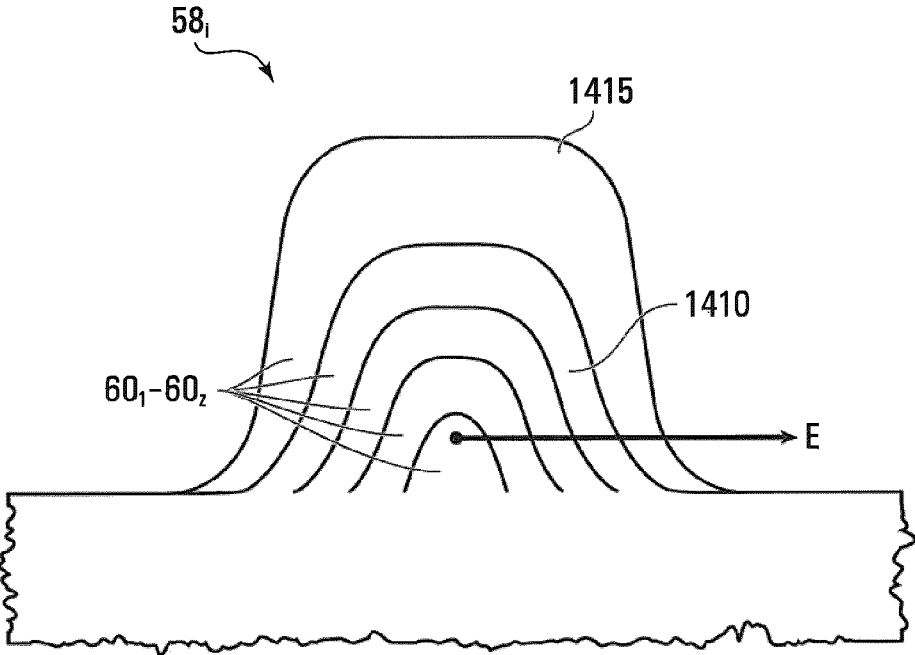

FIG. 19

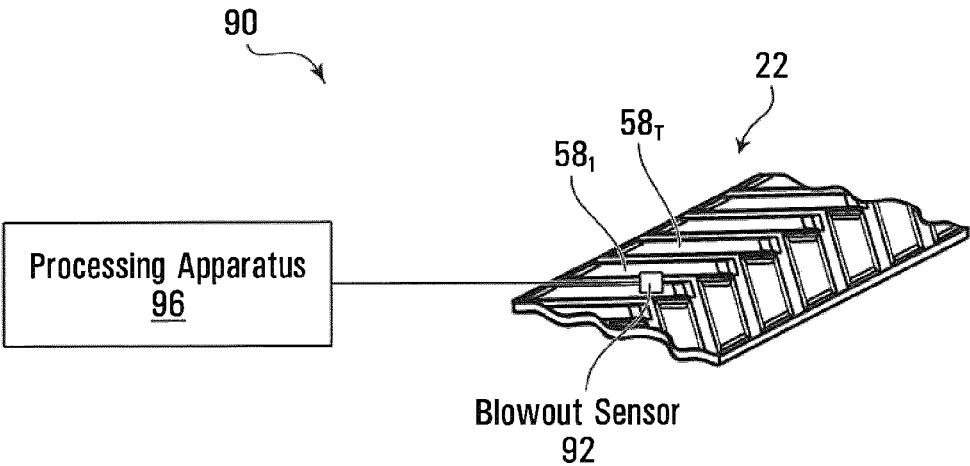

FIG. 20

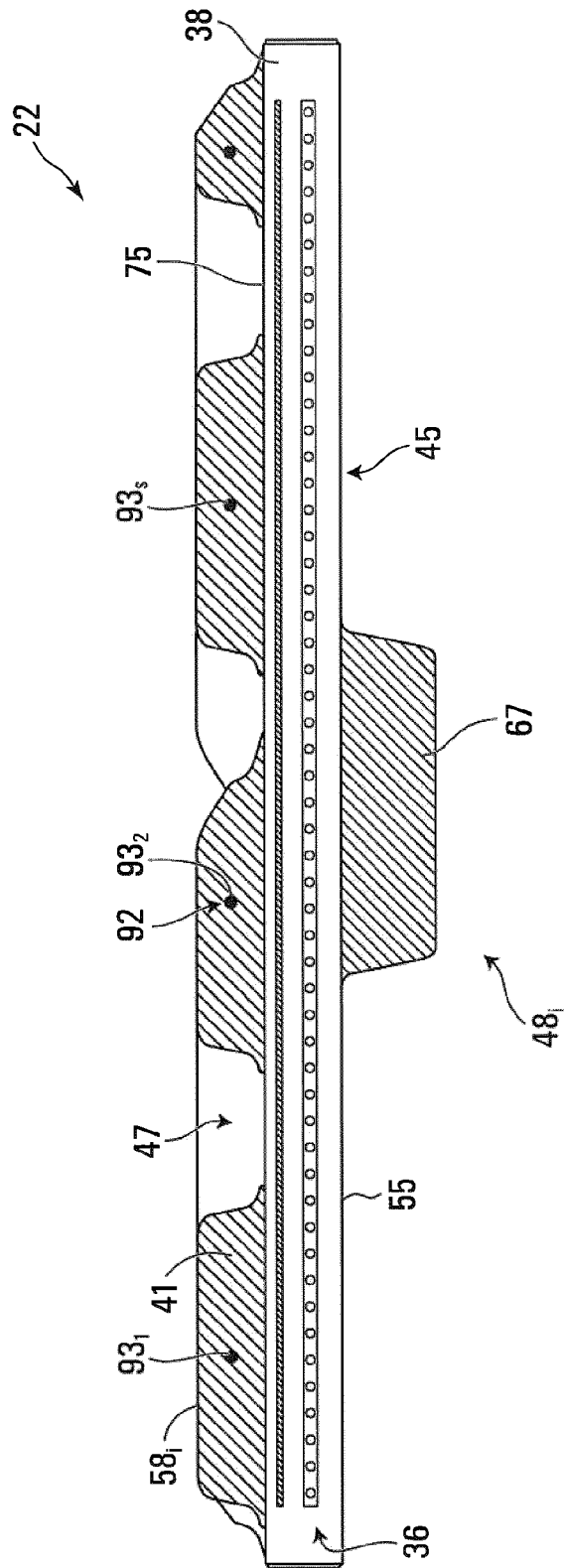

FIG. 21

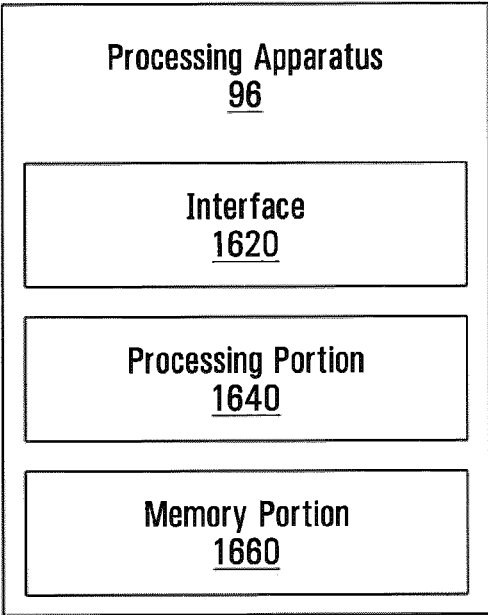

FIG. 22

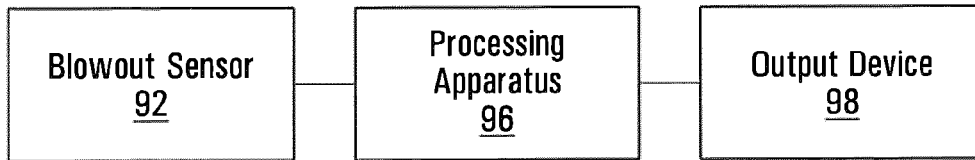

FIG. 23

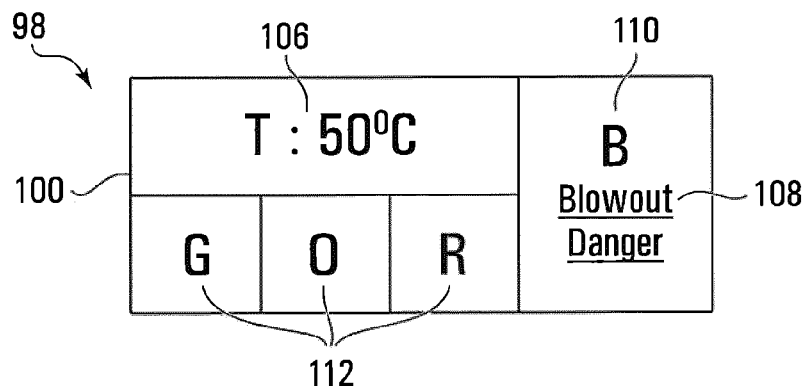

FIG. 24

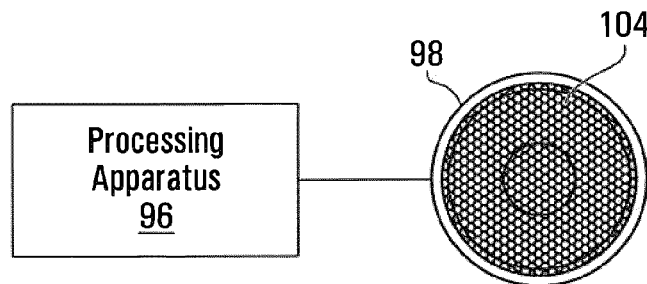

FIG. 25

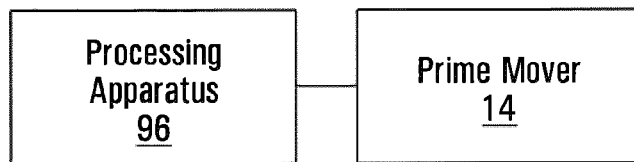

FIG. 26

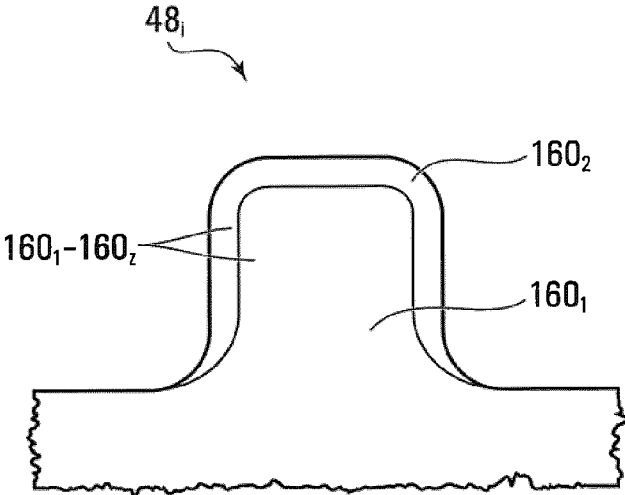

FIG. 27

TRACK SYSTEM FOR TRACTION OF A VEHICLE

CROSS-REFERENCE TO RELATED APPLICATION

[0001] This application claims priority from U.S. Patent Application 62/128,183 filed on Mar. 4, 2015 and hereby incorporated by reference herein.

FIELD OF THE INVENTION

[0002] The invention relates to track systems for traction of off-road vehicles such as, for example, agricultural vehicles, industrial vehicles, and military vehicles.

BACKGROUND

[0003] Certain off-road vehicles, such as agricultural vehicles (e.g., harvesters, combines, tractors, etc.), industrial vehicles such as construction vehicles (e.g., loaders, bulldozers, excavators, etc.) and forestry vehicles (e.g., feller-bunchers, tree chippers, knuckleboom loaders, etc.), and military vehicles (e.g., combat engineering vehicles (CEVs), etc.) to name a few, may be equipped with elastomeric tracks which enhance their traction and floatation on soft, slippery and/or irregular grounds (e.g., soil, mud, sand, ice, snow, etc.) on which they operate.

[0004] An elastomeric track comprises a ground-engaging outer side including a plurality of traction projections, sometimes referred to as “traction lugs”, “tread bars” or “tread blocks”, which are distributed in its longitudinal direction to enhance traction on the ground. Deterioration of the traction projections during use may sometimes become significant enough to force replacement of the track even though the track’s carcass is still in acceptable condition. For example, the traction projections may sometimes “blowout”, i.e., explode, under repeated loads as heat buildup within them increases their internal temperature such that part of their internal elastomeric material decomposes and generates a volatile product which increases internal pressure until they burst. As another example, the traction projections may wear rapidly in some cases (e.g., due to abrasive or harsh ground conditions). Such deterioration of the traction projections may become more prominent, particularly where there is more roading of the track on hard road surfaces (e.g., in an agricultural vehicle travelling on paved roads between fields or other agricultural sites).

[0005] This type of track also comprises an inner side which may include a plurality of drive/guide projections, commonly referred to as “drive/guide lugs”, which are spaced apart along its longitudinal direction and used for driving and/or guiding the track around wheels of a vehicle to which the track provides traction. Wear or other deterioration of the drive/guide lugs (e.g., as they come into contact with one or more of the wheels) often also reduces the track’s useful life.

[0006] For these and other reasons, there is a need to improve elastomeric tracks for traction of vehicles and components of such tracks.

SUMMARY OF THE INVENTION

[0007] According to an aspect of the invention, there is provided a track for traction of a vehicle. The track is mountable around a plurality of wheels that comprises a drive wheel for driving the track. The track is elastomeric to

flex around the wheels. The track comprises: an inner surface for facing the wheels; a ground-engaging outer surface for engaging the ground; and a plurality of traction projections projecting from the ground-engaging outer surface and distributed in a longitudinal direction of the track. Each traction projection of the plurality of traction projections comprises a first material and a second material disposed inwardly of the first material. A blowout resistance of the second material is greater than a blowout resistance of the first material.

[0008] According to another aspect of the invention, there is provided a track for traction of a vehicle. The track is mountable around a plurality of wheels that comprises a drive wheel for driving the track. The track is elastomeric to flex around the wheels. The track comprises: an inner surface for facing the wheels; a ground-engaging outer surface for engaging the ground; and a plurality of traction projections projecting from the ground-engaging outer surface and distributed in a longitudinal direction of the track. Each traction projection of the plurality of traction projections has a blowout time of at least 15 minutes under ASTM D-623 (method A) conditions.

[0009] According to another aspect of the invention, there is provided a method of making a track for traction of a vehicle. The track is mountable around a plurality of wheels that comprises a drive wheel for driving the track. The track is elastomeric to flex around the wheels. The method comprises forming a body of the track. The body comprises an inner surface for facing the wheels and a ground-engaging outer surface for engaging the ground. The method comprises forming a plurality of traction projections projecting from the ground-engaging outer surface and distributed in a longitudinal direction of the track. Each traction projection of the plurality of traction projections comprises a first material and a second material disposed inwardly of the first material. A blowout resistance of the second material is greater than a blowout resistance of the first material.

[0010] According to another aspect of the invention, there is provided a method of making a track for traction of a vehicle. The track is mountable around a plurality of wheels that comprises a drive wheel for driving the track. The track is elastomeric to flex around the wheels. The method comprises forming a body of the track. The body comprises an inner surface for facing the wheels and a ground-engaging outer surface for engaging the ground. The method comprises forming a plurality of traction projections projecting from the ground-engaging outer surface and distributed in a longitudinal direction of the track. Each traction projection of the plurality of traction projections has a blowout time of at least 15 minutes under ASTM D-623 (Method A) conditions.

[0011] According to another aspect of the invention, there is provided a system for protecting a track providing traction to a vehicle. The track is mounted around a plurality of wheels that comprises a drive wheel for driving the track. The track is elastomeric to flex around the wheels. The track comprises: an inner surface for facing the wheels; a ground-engaging outer surface for engaging the ground; and a plurality of traction projections projecting from the ground-engaging outer surface and distributed in a longitudinal direction of the track. The system comprises: a sensor for monitoring the track; and a processing apparatus connected

to the sensor and configured to issue a signal regarding a potential occurrence of blowout of at least one of the traction projections.

[0012] These and other aspects of the invention will now become apparent to those of ordinary skill in the art upon review of the following description of embodiments of the invention in conjunction with the accompanying drawings.

BRIEF DESCRIPTION OF THE DRAWINGS

[0013] A detailed description of embodiments of the invention is provided below, by way of example only, with reference to the accompanying drawings, in which:

[0014] FIG. 1 shows an example of a tracked vehicle comprising a track system in accordance with an embodiment of the invention;

[0015] FIGS. 2 and 3 show a plan view and a side view of a track of the track system;

[0016] FIG. 4 shows an inside view of the track;

[0017] FIG. 5 shows a cross-sectional view of the track;

[0018] FIG. 6 shows a perspective view of traction projection of the track;

[0019] FIG. 7 shows a drive wheel of a track-engaging assembly of the track system;

[0020] FIG. 8 shows a drive/guide projection of the track;

[0021] FIG. 9 shows an example of a test to measure a blowout resistance of a traction projection of the track;

[0022] FIG. 10 shows zones of different materials of a traction projection of the track;

[0023] FIG. 11 shows an example of an embodiment of a traction projection of the track that comprises two zones of different materials varying in blowout resistance and wear resistance;

[0024] FIG. 12 shows another example of an embodiment of a traction projection of the track that comprises multiple layered zones of different materials varying in blowout resistance and wear resistance;

[0025] FIG. 13A shows a graph representing a variation in blowout resistance in relation to a distance within the traction projection of FIG. 12;

[0026] FIG. 13B shows a graph representing a variation in wear resistance in relation to a distance within the traction projection of FIG. 12;

[0027] FIG. 14 shows another example of an embodiment of a traction projection of the track that comprises zones of different materials with different thicknesses;

[0028] FIG. 15A shows a graph representing a variation in blowout resistance along the traction projection of FIG. 14;

[0029] FIG. 15B shows a graph representing a variation in wear resistance across the traction projection of FIG. 14;

[0030] FIG. 16 shows another example of an embodiment of a traction projection of the track that comprises zones of different materials that are mechanically interlocked;

[0031] FIG. 17 shows another example of an embodiment of a traction projection of the track that comprises zones of different materials that vary in blowout resistance and wear resistance;

[0032] FIG. 18A shows a graph representing a variation in blowout resistance along the traction projection of FIG. 17;

[0033] FIG. 18B shows a graph representing a variation in wear resistance along the traction projection of FIG. 17;

[0034] FIG. 19 shows another example of an embodiment of a traction projection of the track that comprises zones of different materials that vary in blowout resistance and wear resistance;

[0035] FIG. 20 shows an example of an embodiment of a blowout protection system of the tracked vehicle, comprising a processing apparatus and a blowout sensor;

[0036] FIG. 21 shows an example of an embodiment in which the blowout sensor is incorporated in the track;

[0037] FIG. 22 shows an example of an embodiment of the processing apparatus;

[0038] FIG. 23 shows an example of implementation in which the processing apparatus interacts with an output device;

[0039] FIG. 24 shows an example of an embodiment in which the output device comprises a display;

[0040] FIG. 25 shows an example of an embodiment in which the output device comprises a speaker;

[0041] FIG. 26 shows a connection between the processing apparatus and a prime mover of the tracked vehicle; and

[0042] FIG. 27 shows an example of a drive/guide projection of the track that comprises zones of different materials varying in blowout resistance and wear resistance, in accordance with another embodiment of the invention.

[0043] It is to be expressly understood that the description and drawings are only for the purpose of illustrating certain embodiments of the invention and are an aid for understanding. They are not intended to be a definition of the limits of the invention.

DETAILED DESCRIPTION OF EMBODIMENTS

[0044] FIG. 1 shows an example of an off-road tracked vehicle 10 in accordance with an embodiment of the invention. In this embodiment, the vehicle 10 is a heavy-duty work vehicle for performing agricultural work, construction or other industrial work, or military work. More particularly, in this embodiment, the vehicle 10 is an agricultural vehicle for performing agricultural work. Specifically, in this example, the agricultural vehicle 10 is a tractor. In other examples, the agricultural vehicle 10 may be a combine harvester, another type of harvester, or any other type of agricultural vehicle.

[0045] The agricultural vehicle 10 comprises a frame 12 supporting a prime mover 14, a pair of track systems 16₁, 16₂ (which can be referred to as “undercarriages”), and an operator cabin 20, which enable an operator to move the agricultural vehicle 10 on the ground to perform agricultural work possibly using a work implement 18.

[0046] The prime mover 14 provides motive power to move the agricultural vehicle 10. For example, the prime mover 14 may comprise an internal combustion engine and/or one or more other types of motors (e.g., electric motors, etc.) for generating motive power to move the agricultural vehicle 10. The prime mover 14 is in a driving relationship with each of the track systems 16₁, 16₂. That is, power derived from the prime mover 14 is transmitted to the track systems 16₁, 16₂ via a powertrain of the agricultural vehicle 10.

[0047] The work implement 18 is used to perform agricultural work. For example, in some embodiments, the work implement 18 may be a combine head, a cutter, a scraper, a tiller, or any other type of agricultural work implement.

[0048] The operator cabin 20 is where the operator sits and controls the agricultural vehicle 10. More particularly, the operator cabin 20 comprises a user interface including a set of controls that allow the operator to steer the agricultural vehicle 10 on the ground and operate the work implement 18.

[0049] The track systems 16_1 , 16_2 engage the ground to propel the agricultural vehicle 10. Each track system 16_i comprises a track-engaging assembly 21 and a track 22 disposed around the track-engaging assembly 21. In this embodiment, the track-engaging assembly 21 comprises a plurality of wheels which, in this example, includes a drive wheel 24 and a plurality of idler wheels that includes a front idler wheel 26 and a plurality of roller wheels 28_1 - 28_6 . The track system 16_i also comprises a frame 13 which supports various components of the track system 16_i , including the roller wheels 28_1 - 28_6 . The track system 16_i has a longitudinal direction and a first longitudinal end 57 and a second longitudinal end 59 that define a length of the track system 16_i . The track system 16_i has a widthwise direction and a width that is defined by a width of the track 22. The track system 16_i also has a height direction that is normal to its longitudinal direction and its widthwise direction.

[0050] The track 22 engages the ground to provide traction to the agricultural vehicle 10. In this embodiment, certain parts of the track 22 are designed to enhance their resistance to deterioration during use, including their resistance to blowout, as further discussed later.

[0051] A length of the track 22 allows the track 22 to be mounted around the track-engaging assembly 21. In view of its closed configuration without ends that allows it to be disposed and moved around the track-engaging assembly 21, the track 22 can be referred to as an “endless” track. With additional reference to FIGS. 2 to 5, the track 22 comprises an inner side 45, a ground-engaging outer side 47, and lateral edges 49_1 , 49_2 . The inner side 45 faces the wheels 24, 26, 28_1 - 28_6 , while the ground-engaging outer side 47 engages the ground. A top run 65 of the track 22 extends between the longitudinal ends 57, 59 of the track system 16, and over the wheels 24, 26, 28_1 - 28_6 , while a bottom run 66 of the track 22 extends between the longitudinal ends 57, 59 of the track system 16, and under the wheels 24, 26, 28_1 - 28_6 . The track 22 has a longitudinal axis 19 which defines a longitudinal direction of the track 22 (i.e., a direction generally parallel to its longitudinal axis) and transversal directions of the track 22 (i.e., directions transverse to its longitudinal axis), including a widthwise direction of the track 22 (i.e., a lateral direction generally perpendicular to its longitudinal axis). The track 22 has a thickness direction normal to its longitudinal and widthwise directions.

[0052] The track 22 is elastomeric, i.e., comprises elastomeric material, to be flexible around the track-engaging assembly 21. The elastomeric material of the track 22 can include any polymeric material with suitable elasticity. In this embodiment, the elastomeric material of the track 22 includes rubber. Various rubber compounds may be used and, in some cases, different rubber compounds may be present in different areas of the track 22. In other embodiments, the elastomeric material of the track 22 may include another elastomer in addition to or instead of rubber (e.g., polyurethane elastomer).

[0053] More particularly, the track 22 comprises an endless body 36 underlying its inner side 45 and ground-engaging outer side 47. In view of its underlying nature, the body 36 will be referred to as a “carcass”. The carcass 36 is elastomeric in that it comprises elastomeric material 38 which allows the carcass 36 to elastically change in shape and thus the track 22 to flex as it is in motion around the

track-engaging assembly 21. The carcass 36 comprises an inner surface 32 and a ground-engaging outer surface 31 that are opposite one another.

[0054] In this embodiment, the carcass 36 comprises a plurality of reinforcements embedded in its elastomeric material 38. These reinforcements can take on various forms.

[0055] For example, in this embodiment, the carcass 36 comprises a layer of reinforcing cables 37_1 - 37_M that are adjacent to one another and extend generally in the longitudinal direction of the track 22 to enhance strength in tension of the track 22 along its longitudinal direction. In this case, each of the reinforcing cables 37_1 - 37_M is a cord including a plurality of strands (e.g., textile fibers or metallic wires). In other cases, each of the reinforcing cables 37_1 - 37_M may be another type of cable and may be made of any material suitably flexible along the cable’s longitudinal axis (e.g., fibers or wires of metal, plastic or composite material).

[0056] As another example, in this embodiment, the carcass 36 comprises a layer of reinforcing fabric 43. The reinforcing fabric 43 comprises thin pliable material made usually by weaving, felting, knitting, interlacing, or otherwise crossing natural or synthetic elongated fabric elements, such as fibers, filaments, strands and/or others, such that some elongated fabric elements extend transversally to the longitudinal direction of the track 22 to have a reinforcing effect in a transversal direction of the track 22. For instance, the reinforcing fabric 43 may comprise a ply of reinforcing woven fibers (e.g., nylon fibers or other synthetic fibers).

[0057] The carcass 36 has a thickness T_c , measured from its inner surface 32 to its ground-engaging outer surface 31, which is relatively large in this embodiment. For example, in some embodiments, the thickness T_c of the carcass 36 may be at least 20 mm, in some cases at least 25 mm, in some cases at least 30 mm, in some cases at least 35 mm, and in some cases even more (e.g., 40 mm or more). The thickness T_c of the carcass 36 may have any other suitable value in other embodiments.

[0058] The carcass 36 may be molded into shape in a molding process during which the rubber 38 is cured. For example, in this embodiment, a mold may be used to consolidate layers of rubber providing the rubber 38 of the carcass 36, the reinforcing cables 37_1 - 37_M and the layer of reinforcing fabric 43.

[0059] In this embodiment, the endless track 22 is a one-piece “jointless” track such that the carcass 36 is a one-piece jointless carcass. In other embodiments, the endless track 22 may be a “jointed” track (i.e., having at least one joint connecting adjacent parts of the track 22) such that the carcass 36 is a jointed carcass (i.e., which has adjacent parts connected by the at least one joint). For example, in some embodiments, the track 22 may comprise a plurality of track sections interconnected to one another at a plurality of joints, in which case each of these track sections includes a respective part of the carcass 36. In other embodiments, the endless track 22 may be a one-piece track that can be closed like a belt with connectors at both of its longitudinal ends to form a joint.

[0060] The inner side 45 of the endless track 22 comprises an inner surface 55 of the carcass 36 and a plurality of inner wheel-contacting projections 48_1 - 48_N that project from the inner surface 55 and are positioned to contact at least some of the wheels 24, 26, 28_1 - 28_6 to do at least one of driving (i.e., imparting motion to) the track 22 and guiding the track

22. The wheel-contacting projections 48_1-48_N can be referred to as “wheel-contacting lugs”. Furthermore, since each of them is used to do at least one of driving the track 22 and guiding the track 22, the wheel-contacting lugs 48_1-48_N can be referred to as “drive/guide projections” or “drive/guide lugs”. In some examples of implementation, a drive/guide lug 48_i may interact with the drive wheel 24 to drive the track 22, in which case the drive/guide lug 48_i is a drive lug. In other examples of implementation, a drive/guide lug 48_i may interact with the idler wheel 26 and/or the roller wheels 28_1-28_6 to guide the track 22 to maintain proper track alignment and prevent de-tracking without being used to drive the track 22, in which case the drive/guide lug 48_i is a guide lug. In yet other examples of implementation, a drive/guide lug 48_i may both (i) interact with the drive wheel 24 to drive the track and (ii) interact with the idler wheel 26 and/or the roller wheels 28_1-28_6 to guide the track 22 to maintain proper track alignment and prevent de-tracking, in which case the drive/guide lug 48_i is both a drive lug and a guide lug.

[0061] In this embodiment, the drive/guide lugs 48_1-48_N interact with the drive wheel 24 in order to cause the track 22 to be driven, and also interact with the idler wheel 26 and the roller wheels 28_1-28_6 in order to guide the track 22 as it is driven by the drive wheel 24 to maintain proper track alignment and prevent de-tracking. The drive/guide lugs 48_1-48_N are thus used to both drive the track 22 and guide the track 22 in this embodiment.

[0062] In this example of implementation, the drive/guide lugs 48_1-48_N are arranged in a single row disposed longitudinally along the inner side 45 of the track 22. The drive/guide lugs 48_1-48_N may be arranged in other manners in other examples of implementation (e.g., in a plurality of rows that are spaced apart along the widthwise direction of the track 22).

[0063] In this embodiment, each drive/guide lug 48_i is an elastomeric drive/guide lug in that it comprises elastomeric material 67. The elastomeric material 67 can be any polymeric material with suitable elasticity. More particularly, in this embodiment, the elastomeric material 67 includes rubber. Various rubber compounds may be used and, in some cases, different rubber compounds may be present in different areas of the drive/guide lug 48_i . In other embodiments, the elastomeric material 67 may include another elastomer in addition to or instead of rubber (e.g., polyurethane elastomer). The drive/guide lugs 48_1-48_N may be provided on the inner side 45 in various ways. For example, in this embodiment, the drive/guide lugs 48_1-48_N are provided on the inner side 45 by being molded with the carcass 36.

[0064] The ground-engaging outer side 47 comprises a ground-engaging outer surface 75 of the carcass 36 and a tread pattern 40 to enhance traction on the ground.

[0065] The tread pattern 40 comprises a plurality of traction projections 58_1-58_T projecting from the ground-engaging outer surface 75, spaced apart in the longitudinal direction of the endless track 22 and engaging the ground to enhance traction. The traction projections 58_1-58_T may be referred to as “tread projections” or “traction lugs”.

[0066] The traction lugs 58_1-58_T may have any suitable shape. In this embodiment, each of the traction lugs 58_1-58_T has an elongated shape and is angled, i.e., defines an oblique angle θ (i.e., an angle that is not a right angle or a multiple of a right angle), relative to the longitudinal direction of the track 22. The traction lugs 58_1-58_T may have various other

shapes in other examples (e.g., curved shapes, shapes with straight parts and curved parts, etc.).

[0067] As shown in FIG. 6, each traction lug 58_i has a periphery 69 which includes a front surface 80_1 , a rear surface 80_2 , two side surfaces 81_1 , 81_2 , and a top surface 86. The front surface 80_1 and the rear surface 80_2 are opposed to one another in the longitudinal direction of the track 22. The two side faces 81_1 , 81_2 are opposed to one another in the widthwise direction of the track 22. In this embodiment, the front surface 80_1 , the rear surface 80_2 , and the side surfaces 81_1 , 81_2 are substantially straight. The periphery 69 of the traction lug 58_i may have any other shape in other embodiments (e.g., the front surface 80_1 , the rear surface 80_2 , and/or the side surfaces 81_1 , 81_2 may be curved). The traction lug 58_i has a front-to-rear dimension L_L in the longitudinal direction of the track 22, a side-to-side dimension L_W in the widthwise direction of the track 22, and a height H in the thickness direction of the track 22.

[0068] In this embodiment, each traction lug 58_i is an elastomeric traction lug in that it comprises elastomeric material 41. The elastomeric material 41 can be any polymeric material with suitable elasticity. More particularly, in this embodiment, the elastomeric material 41 includes rubber. Various rubber compounds may be used and, in some cases, different rubber compounds may be present in different areas of the traction lug 58_i . In other embodiments, the elastomeric material 41 may include another elastomer in addition to or instead of rubber (e.g., polyurethane elastomer). The traction lugs 58_1-58_T may be provided on the ground-engaging outer side 27 in various ways. For example, in this embodiment, the traction lugs 58_1-58_T are provided on the ground-engaging outer side 27 by being molded with the carcass 36.

[0069] The track 22 may be constructed in various other manners in other embodiments. For example, in some embodiments, the track 22 may have recesses or holes that interact with the drive wheel 24 in order to cause the track 22 to be driven (e.g., in which case the drive/guide lugs 48_1-48_N may be used only to guide the track 22 without being used to drive the track 22, i.e., they may be “guide lugs” only), and/or the ground-engaging outer side 47 of the track 22 may comprise various patterns of traction lugs.

[0070] The drive wheel 24 is rotatable by power derived from the prime mover 14 to drive the track 22. That is, power generated by the prime mover 14 and delivered over the powertrain of the agricultural vehicle 10 can rotate a driven axle, which causes rotation of the drive wheel 24, which in turn imparts motion to the track 22.

[0071] With additional reference to FIG. 7, in this embodiment, the drive wheel 24 comprises a drive sprocket comprising a plurality of drive members 52_1-52_B spaced apart along a circular path to engage the drive/guide lugs 48_1-48_N of the track 22 in order to drive the track 22. The drive wheel 24 and the track 22 thus implement a “positive drive” system. More particularly, in this embodiment, the drive wheel 24 comprises two side discs 50_1 , 50_2 which are co-centric and turn about a common axle 51 and between which the drive members 52_1-52_B extend near respective peripheries of the side discs 50_1 , 50_2 . In this example, the drive members 52_1-52_B are thus drive bars that extend between the side discs 50_1 , 50_2 . The drive wheel 24 and the track 22 have respective dimensions allowing interlocking of the drive bars 52_1-52_B of the drive wheel 24 and the drive/guide lugs 48_1-48_N of the track 22. Adjacent ones of

the drive bars 52₁-52_B define an interior space 53 between them to receive one of the drive/guide lugs 48₁-48_N. Adjacent ones of the drive/guide lugs 48₁-48_N define an inter-lug space 39 between them to receive one of the drive bars 52₁-52_B. The drive/guide lugs 48₁-48_N and the drive bars 52₁-52_B have a regular spacing that allows interlocking of the drive/guide lugs 48₁-48_N and the drive bars 52₁-52_B over a certain length of the drive wheel's circumference.

[0072] The drive wheel 24 may be configured in various other ways in other embodiments. For example, in other embodiments, the drive wheel 24 may not have any side discs such as the side discs 50₁, 50₂. As another example, in other embodiments, instead of being drive bars, the drive members 52₁-52_B may be drive teeth that are distributed circumferentially along the drive wheel 24 or any other type of drive members. As another example, in embodiments where the track 22 comprises recesses or holes, the drive wheel 24 may have teeth that enter these recesses or holes in order to drive the track 22. As yet another example, in some embodiments, the drive wheel 24 may frictionally engage the inner side 45 of the track 22 in order to frictionally drive the track 22 (i.e., the drive wheel 24 and the track 22 may implement a "friction drive" system).

[0073] The front idler wheel 26 and the roller wheels 28₁-28₆ are not driven by power supplied by the prime mover 14, but are rather used to do at least one of supporting part of the weight of the agricultural vehicle 10 on the ground via the track 22, guiding the track 22 as it is driven by the drive wheel 24, and tensioning the track 22. More particularly, in this embodiment, the front idler wheel 26 is a leading idler wheel which maintains the track 22 in tension and helps to support part of the weight of the agricultural vehicle 10 on the ground via the track 22. As shown in FIG. 8, the roller wheels 28₁-28₆ roll on a rolling path 33 of the inner side 45 of the track 22 along the bottom run 66 of the track 22 to apply the bottom run 66 on the ground. In this case, as they are located between frontmost and rearmost ones of the wheels of the track system 16_r, the roller wheels 28₁-28₆ can be referred to as "mid-rollers".

[0074] The traction lugs 58₁-58_T can be designed to enhance their resistance to deterioration during use. Notably, in this embodiment, a blowout resistance of each traction lug 58_i can be enhanced to prevent or at least reduce a potential for blowout of the traction lug 58_i under repeated loads which may induce heat buildup within it. Also, a wear resistance of the traction lug 58_i may be enhanced such that the traction lug 58_i wears less rapidly. This enhanced resistance to deterioration of the traction lugs 58₁-58_T may be particularly useful in situations where the track 22 experiences significant roading on hard road surfaces, such as, for example, when the agricultural vehicle 10 travels on paved roads between fields or other agricultural sites.

[0075] More particularly, in this embodiment, the blowout resistance of a traction lug 58_i is greater than a threshold.

[0076] A test may be performed to measure the blowout resistance of the traction lug 58_i. For example, with additional reference to FIG. 9, a sample of the traction lug 58_i of specified dimensions can be repeatedly compressed at a specified frequency by applying a load causing a specified deformation (e.g., compression) and measuring one or more parameters indicative of the blowout resistance of the traction lug 58_i.

[0077] For instance, in some embodiments, the test may be a standard test. In some cases, the blowout resistance of the

traction lug 58_i may be measured under ASTM D-623 (Method A) conditions (e.g., sample dimensions, load, frequency and deformation specified by ASTM D-623).

[0078] For example, according to ASTM D-623 (Method A), a sample of the traction lug 58_i of specified dimensions (i.e., a diameter of 17.8+/-0.1 mm and a height of 25+/-0.15 mm) can be taken from the traction lug 58_i, subjected to a specified preload (i.e., 110 lbs), conditioned at a specified temperature (i.e., 100° C.) for a specified period of time (i.e., 25 minutes), and repeatedly compressed by causing a specified deformation (e.g., compression) (i.e., 0.250 inches in amplitude) at a specified frequency (i.e., 30 Hz) in order to measure one or more parameters indicative of the blowout resistance of the traction lug 58_i. This may be performed using a Goodrich flexometer.

[0079] Various parameters may be measured during the test to assess the blowout resistance of the traction lug 58_i. For example:

[0080] a) A blowout time B at which blowout of the sample of the traction lug 58_i occurs. The blowout time B can be measured by repeatedly loading the sample of the traction lug 58_i until blowout (i.e., it explodes) and noting a period of time (e.g., in minutes) to reach that blowout point or as otherwise specified by the test if standard. For example, in some embodiments, the blowout time B at which blowout of the sample of the traction lug 58_i occurs may be at least 15 minutes, in some cases at least 20 minutes, in some cases at least 25 minutes, in some cases at least 30 minutes, in some cases at least 40 minutes, in some cases at least 50 minutes, and in some cases even more (e.g., at least 60, 80 or 100 minutes); and/or

[0081] b) A blowout temperature T_b of the sample of the traction lug 58_i at which blowout of the sample of the traction lug 58_i occurs. The blowout temperature T_b can be measured by repeatedly loading the sample of the traction lug 58_i until blowout (i.e., it explodes) and measuring that temperature at a hottest point of the sample of the traction lug 58_i (e.g., using a temperature probe) or as otherwise specified by the test if standard. For example, in some embodiments, the blowout temperature T_b of the sample of the traction lug 58_i at which blowout of the sample of the traction lug 58_i occurs may be at least 180° C., in some cases at least 190° C., in some cases at least 200° C., in some cases at least 210° C., and in some cases even more (e.g., at least 220° C.).

[0082] The blowout time B of the sample of the traction lug 58_i and/or the blowout temperature T_b of the sample of the traction lug 58_i may have any other suitable value in other examples of implementation.

[0083] Also, in this embodiment, the wear resistance of a traction lug 58_i is greater than a threshold. For example, in some embodiments, the wear resistance of the traction lug 58_i may be expressed as an abrasion resistance of the traction lug 58_i.

[0084] A test may be performed to measure the wear resistance of the traction lug 58_i. For example, in some embodiments, a sample of the traction lug 58_i of specified dimensions can be moved across a surface of an abrasive sheet mounted to a revolving drum to measure the wear of the traction lug 58_i as a volume loss in cubic millimeters or an abrasion resistance index in percent. In some cases, the test may be a standard test. For instance, in some embodiments, the wear resistance of the traction lug 58_i, expressed

as its abrasion resistance, may be measured under ASTM D-5963 conditions (e.g., sample dimensions; loading conditions; etc.).

[0085] For example, a sample of the traction lug 58_i of dimensions specified by ASTM D-5963 (i.e., a diameter of 16 ± 0.2 mm and a minimum thickness of 6 mm) can be taken from the traction lug 58_i and moved against a surface of an abrasive sheet mounted to a revolving drum as specified by ASTM D-5963 and measuring one or more parameters indicative of the abrasion resistance of the traction lug 58_i .

[0086] For instance, in some embodiments, a volume loss in cubic millimeters of the sample of the traction lug 58_i (according to abrasion loss method A) may be no more than 110 mm^3 , in some cases no more than 100 mm^3 , more than 90 mm^3 , in some cases no more than 80 mm^3 , and in some cases even less (e.g., no more than 70 mm^3 or 60 mm^3). The volumetric loss of the sample of the traction lug 58_i may have any other suitable value in other examples of implementation.

[0087] Enhancement of the resistance to deterioration of the traction lugs 58_1-58_z , including their resistance to blowout, may be achieved in various ways in various embodiments.

[0088] In this embodiment, each traction lug 58_i is characterized by a material distribution profile to enhance its resistance to deterioration, including its blowout resistance and its wear resistance. With additional reference to FIG. 10, the material distribution profile is designed such that the traction lug 58_i has a material composition defining an arrangement of zones of different materials 60_1-60_z . These different materials 60_1-60_z belong to different classes of materials (i.e., polymers, metals, ceramics and composites) and/or exhibit substantially different values of a given material property (e.g., a modulus of elasticity, tensile strength, hardness, friction coefficient, crack growth resistance, etc.). The arrangement of zones of different materials 60_1-60_z is designed into the traction lug 58_i . That is, the arrangement of zones of different materials 60_1-60_z does not occur by chance (e.g., during manufacturing or use of the traction lug 58_i), but is rather achieved by a careful material selection and distribution within the traction lug 58_i during design of the track 22.

[0089] The arrangement of zones of different materials 60_1-60_z may comprise two, three, four, five or more zones of different materials. Also, while the arrangement of zones of different materials 60_1-60_z may comprise any selection of different materials, in some embodiments, the arrangement of zones of different materials 60_1-60_z may comprise a plurality of zones of different elastomeric materials (i.e., two, three, four, five or more zones of different elastomeric materials). For example, such different elastomeric materials may include different rubbers, thermoplastic elastomers (TPE) such as polyurethane elastomers, and/or other elastomers.

[0090] The zones of different materials 60_1-60_z may be provided in any suitable way using one or more manufacturing processes, such as, for example, a molding process (e.g., an injection molding process, a compression molding process, etc.), an extrusion process (e.g., a coextrusion process), a pouring process, a gluing process, a coating process, a heat treatment, a penetrating treatment (e.g., an electromagnetic radiation treatment, etc.), and/or any other suitable manufacturing process. Examples of how the zones

of different materials 60_1-60_z may be provided in various embodiments are discussed below.

[0091] More particularly, in this embodiment, the arrangement of zones of different materials 60_1-60_z is configured such that the traction lug 58_i exhibits a desired variation in blowout resistance across the arrangement of zones of different materials 60_1-60_z . Also, in this embodiment, the arrangement of zones of different materials 60_1-60_z is configured such that the traction lug 58_i exhibits a desired variation in wear resistance across the arrangement of zones of different materials 60_1-60_z . Each of these variations is “desired” in that it is designed into the traction lug 58_i by the careful material selection and distribution within the traction lug 58_i to create the arrangement of zones of different materials 60_1-60_z during design of the track 22 such that the blowout resistance and the wear resistance vary in an intended manner. In that sense, these desired variations can also be referred to as a “selected”, “predetermined”, “intended” or “controlled” variation in blowout resistance and wear resistance.

[0092] Specifically, in this example of implementation, the blowout resistance increases inwardly, i.e., in a direction away from the periphery 69 of the traction lug 58_i towards an inside of the traction lug 58_i . Thus, in this example, the blowout resistance of an inner material 60_x of the traction lug 58_i is greater than the blowout resistance of an outer material 60_y of the traction lug 58_i . The inner material 60_x and the outer material 60_y are respectively referred to as being “inner” and “outer” in that the inner material 60_x is disposed inwardly of the outer material 60_y , i.e., the outer material 60_y is disposed between the inner material 60_x and the periphery 69 of the traction lug 58_i (e.g., and may extend to the periphery 69 of the traction lug 58_i). The outer material 60_y is thus closer to the periphery 69 of the traction lug 58_i than the inner material 60_x (e.g., and may extend to the periphery 69 of the traction lug 58_i). The blowout resistance of the inner material 60_x of the traction lug 58_i may be measured by subjecting a sample of the inner material 60_x to a test as described above and measuring one or more parameters indicative of its blowout resistance, such as the blowout temperature T_b of the sample of the inner material 60_x and/or the blowout time B of the sample of the inner material 60_x . A similar procedure may be followed for measuring the blowout resistance of the outer material 60_y of the traction lug 58_i .

[0093] Also, in this example of implementation, the wear resistance increases outwardly, i.e., in a direction towards the periphery 69 of the traction lug 58_i . More particularly, in this example, the wear resistance of the outer material 60_y of the traction lug 58_i is greater than the wear resistance of the inner material 60_x of the traction lug 58_i . The wear resistance of the outer material 60_y of the traction lug 58_i may be measured by subjecting a sample of the outer material 60_y to a test as described above and measuring one or more parameters indicative of its wear resistance, such as its abrasion resistance. A similar procedure may be followed for measuring the wear resistance of the inner material 60_x of the traction lug 58_i .

[0094] The traction lug 58_i is thus more resistant to blowout in its internal region which would be more susceptible to blowout conditions, while being more wear resistance in its external region which is exposed to wearing effects.

[0095] The variation in blowout resistance and wear resistance across the arrangement of zones of different materials

60_1 - 60_z of the traction lug 58_i may be configured in various ways. For example, in various embodiments, this may include one or more gradients of blowout resistance and wear resistance across the zones of different materials 60_1 - 60_z of the traction lug 58_i , where each gradient can be a discrete gradient or a continuous gradient.

[0096] i. Discrete Gradient

[0097] In some embodiments, the arrangement of zones of different materials 60_1 - 60_z of the traction lug 58_i may exhibit a discrete gradient of blowout resistance and a discrete gradient of wear resistance. A discrete gradient of blowout resistance or wear resistance is a discrete variation of the blowout resistance or wear resistance in a specified direction across the arrangement of zones of different materials 60_1 - 60_z of the traction lug 58_i . In such embodiments, adjacent ones of the zones of different materials 60_1 - 60_z which define the discrete gradient of blowout resistance or wear resistance are discrete zones such that the blowout resistance or the wear resistance varies in discrete steps across the traction lug 58_i . A zone is “discrete” in that its dimension along the specified direction of the discrete gradient is macroscopically measurable.

[0098] For example, FIG. 11 shows an example of an embodiment in which the blowout resistance and the wear resistance vary in discrete steps such that the zones of different materials 60_1 - 60_z have different blowout resistance and wear resistance values.

[0099] In this embodiment, the arrangement of zones of different materials 60_1 - 60_z includes an outer material 60_1 and an inner material 60_2 . The outer material 60_1 is an external material and forms the periphery 69 of the traction lug 58_i , while the inner material 60_2 is a core material forming a core of the traction lug 58_i . In this example, the inner material 60_2 has a higher blowout resistance than the outer material 60_1 . On the other hand, the outer material 60_1 has a higher wear resistance than the inner material 60_2 . Thus, the inner material 60_2 is more resistant to blowout than the outer material 60_1 , whereas the outer material 60_1 is more resistant to wear than the inner material 60_2 .

[0100] To this end, in some embodiments, the outer material 60_1 and the inner material 60_2 may be different elastomeric materials (e.g., rubbers, thermoplastic elastomers (TPE) such as polyurethane elastomers, and/or other elastomers). For instance, in some embodiments, the inner material 60_2 and the outer material 60_1 may be different types of rubber. For example, the different rubber compounds constituted by the inner material 60_2 and the outer material 60_1 may differ by having different base polymers, different concentration and/or types of carbon black, different content of dienes, and/or different content of sulfur or other vulcanizing and/or in any other suitable manner.

[0101] In other embodiments, one or both of the inner material 60_2 and the outer material 60_1 may be other types of materials, including non-elastomeric materials. For example, in some embodiments, the outer material 60_1 may be thermoplastic olefin (TPO), nylon, polytetrafluoroethylene (PTFE) or any other thermoplastic material. As another example, in some embodiments, the inner material 60_2 may comprise metal, rigid polymer (e.g., thermoplastic), ceramic or any other material with a suitable blowout resistance, i.e., a blowout resistance higher than that of the outer material 60_1 .

[0102] There may be any suitable proportions of the outer material 60_1 and the inner material 60_2 in the traction lug 58_i .

For example, in some embodiments, a ratio V_b/V_t of a volume V_b of the inner material 60_2 over a volume V_t of the traction lug 58_i may be at least 0.1, in some cases at least 0.2, in some cases at least 0.3, in some cases at least 0.4, in some cases at least 0.5, in some cases at least 0.6, and in some cases even more (e.g., at least 0.8 or 0.9). In some embodiments, a ratio G_b/G_t of a dimension G_b of the inner material 60_2 in a given direction (e.g., in the thickness direction of the track 22) over a dimension G_t of the traction lug 58_i in that given direction (e.g., the height H of the traction lug 58) may be at least 0.1, in some cases at least 0.2, in some cases at least 0.3, in some cases at least 0.4, in some cases at least 0.5, in some cases at least 0.6, and in some cases even more (e.g., at least 0.8 or 0.9).

[0103] Although a particular material distribution profile is shown in the above embodiment for illustrative purposes to show an example of the arrangement of zones of different materials 60_1 - 60_z , various other different material distribution profiles may be realized in other embodiments to create various other arrangements of zones of different materials 60_1 - 60_z by varying a number of zones, sizes, geometries and locations of zones, and/or materials of the zones.

[0104] For instance, in other embodiments, the number of zones and the geometry of the zones may be varied. For example, in some embodiments, more zones of different materials 60_1 - 60_z may be provided to achieve a more complex blowout resistance and wear resistance variation profile.

[0105] By selecting a number of zones, sizes, geometries and locations of zones, and/or materials of the zones, it is possible to regulate how the blowout resistance and the wear resistance change across the arrangement of zones of different materials 60_1 - 60_z of the traction lug 58_i . In the above embodiment, the blowout resistance and the wear resistance vary across the traction lug 58_i in a discrete step, which corresponds to a transition between the outer material 60_1 and the inner material 60_2 . There may be two (2), three (3), four (4), five (5) or more (e.g., 10 or 20) discrete steps in other embodiments. By providing a large number of zones of different materials 60_1 - 60_z having different blowout resistance and wear resistance values, it is possible to approximate a smooth variation in blowout resistance and wear resistance, the actual granularity of which will depend upon the number and size of the zones of different materials 60_1 - 60_z .

[0106] FIG. 12 shows another embodiment of a traction lug 58_i in which the blowout resistance and the wear resistance vary in discrete steps such that the zones of different materials 60_1 - 60_z have different blowout resistance and wear resistance values.

[0107] More particularly, in this embodiment, the arrangement of zones of different materials 60_1 - 60_z of the traction lug 58_i comprises a core material 60_1 and a plurality of layered materials, including a first layered material 60_2 , a second layered material 60_3 , a third layered material 60_4 and a fourth layered material 60_5 , which make up a layered area 1120 . In this example, the layered materials 60_2 - 60_5 are approximately equal in thickness. Different ones of the layered materials 60_2 - 60_5 may have different thicknesses in other examples.

[0108] FIG. 13A is a graph 1200 showing an example of how the blowout resistance 1205 of the traction lug 58_i varies as a function of distance within the traction lug 58_i in a specified direction represented by line B shown in FIG. 12.

As the distance along line B is varied, the blowout resistance of the traction lug **58_i**, takes on five (5) different values λ_{60-1} , λ_{60-2} , λ_{60-3} , λ_{60-4} and λ_{60-5} , each of which corresponds to the blowout resistance of a respective one of the zones of different materials **60₁-60₅**. As such, the function of the blowout resistance **1205** takes the form of a step function, each step corresponding to a respective one of the zones of different materials **60₁-60_z**. The layered materials **60₂-60₅** are represented in range **1210** of the graph **1200**, while range **1215** represents the core material **60₁**. In range **1210**, the blowout resistance of the traction lug **58_i**, approximates a linear function **1220**. As such, the layered area **1120** can be viewed as exhibiting an approximately linear variation in blowout resistance with an actual granularity defined by the steps in the function of the blowout resistance **1205** corresponding to the layered materials **60₂-60₅**. The overall function blowout resistance **1205** across line B in this example can thus be considered to approximate smooth line **1225**.

[0109] In this example, the values of blowout resistance λ_{60-1} , λ_{60-2} , λ_{60-3} , λ_{60-4} and λ_{60-5} vary from one material to the next by approximately the same value, giving steps of approximately equal height in the vertical direction of the graph **1200**. Similarly, the layered materials **60₂-60₅** have approximately equal thicknesses such that the steps have approximately equal width in the horizontal (distance along line B) direction of the graph **1200**. The linear function **1220** which is approximated by the function of the blowout resistance **1205** in the layered area **1120** can be varied by altering the thicknesses of the layered materials **60₂-60₅** and/or by varying the blowout resistance values λ_{60-2} , λ_{60-3} , λ_{60-4} and λ_{60-5} of the layered materials **60₂-60₅**. For example, the rate of change (slope) of the approximated linear function **1220** may be decreased by increasing the thickness or decreasing the variation in the blowout resistance in the different materials.

[0110] In a similar manner, the wear resistance of the traction lug **58_i**, varies as a function of distance within the traction lug **58_i**, in a specified direction represented by line B shown in FIG. **12**. However, the wear resistance defines an inverse relationship to the blowout resistance. That is, while the blowout resistance is highest at the core material **60₁** and lowest at the layered material **60₅**, the wear resistance is highest at the layered material **60₅** and lowest at the core material **60₁**.

[0111] FIG. **13B** is a graph **1300** showing an example of how the wear resistance **1305** of the traction lug **58_i**, varies as a function of distance within the traction lug **58_i**, in a specified direction represented by line B shown in FIG. **11**. As the distance along line B is varied, the wear resistance of the traction lug **58_i**, takes on five (5) different values β_{60-1} , β_{60-2} , β_{60-3} , β_{60-4} and β_{60-5} , each of which corresponds to the wear resistance of the material of a respective one of the materials **60₁-60₅**. As such, the function of the wear resistance **1305** takes the form of a step function, each step corresponding to a respective one of the zones of different materials **60₁-60_z**. The layered materials **60₂-60₅** are represented in range **1310** of the graph **1300**, while range **1315** represents the core material **60₁**. In range **1310**, the wear resistance of the traction lug **58_i**, approximates a linear function **1320**. As such, the layered area **1120** can be viewed as exhibiting an approximately linear variation in wear resistance with an actual granularity defined by the steps in the function of the wear resistance **1305** corresponding to

the layered materials **60₂-60₅**. The overall wear resistance **1305** function across line B in this example can thus be considered to approximate smooth line **1325**.

[0112] The manner in which approximation of a function is determined may affect the thicknesses of the zones of different materials **60₁-60_z** required to approximate the function. For example, in some embodiments, the linear function **1220** may be arrived at by taking a weighted average of the blowout resistance values λ_{60-1} , λ_{60-2} , λ_{60-3} , λ_{60-4} and λ_{60-5} of each material, wherein the thickness of each material determines the weight, and dividing the result by the average thickness of a material. This may provide the slope of the linear function **1220**. A similar procedure may be implemented to approximate the linear function **1320**. Other models may be used in other embodiments to approximate functions of variation of a material property depending on the method used.

[0113] Depending on the materials available, on the blowout resistance and wear resistance of available materials, and on the inter-compatibility of materials from which the traction lug **58_i**, may be made, it may not be practical in some embodiments to obtain equidistant blowout resistance and wear resistance values for each of the zones of different materials **60₁-60_z**. As such, in some cases, the materials used or available may not provide equal heights for each step in the function of the blowout resistance **1205** and/or the wear resistance **1305**. In such cases, the thicknesses of the zones of different materials **60₁-60_z** may be modified to adjust the weight of each material such that, on average, the linear function **1220** and the linear function **1320** are still approximated. This would have the effect of altering the horizontal length of the steps in the graphs **1200**, **1300** to compensate for inequality in the vertical height of the steps, so as to achieve an approximation of linear functions **1220**, **1320**. Alternatively, the blowout resistance and wear resistance of other materials may be adjusted, insofar as possible or practical, such as to approximate the linear functions **1220**, **1320**. This would have the effect of varying the vertical height of steps in the graphs **1200**, **1300** to compensate for another step that is too tall or too short so as to approximate the linear functions **1220**, **1320**.

[0114] In this embodiment, the arrangement of zones of different materials **60₁-60_z** has been selected based on blowout resistance and wear resistance values so as to achieve an approximation, according to a selected curve-fitting method, of the linear functions **1220**, **1320**. In other embodiments, the blowout resistance and wear resistance variation may be a nonlinear variation of a function of distance within the traction lug **58_i**. In yet other embodiments, there may be no approximation of a linear or other function. In such embodiments, the various materials for the zones of different materials **60₁-60_z** may be selected on the basis of the desired blowout resistance and wear resistance in each zone of the zones of different materials **60₁-60_z**, without regards to any linear or other function.

[0115] FIG. **14** shows another example of an embodiment of a traction lug **58_i**, in which the blowout resistance and the wear resistance vary in discrete steps such that the zones of different materials **60₁-60_z** have different blowout resistance and wear resistance values. In this embodiment, an entirety of the traction lug **58_i**, is made up of zones of different materials **60₁-60_z** that may be considered layered materials. Also, in this embodiment, the traction lug **58_i**, comprises an inner area **1140** where the layered materials form thicker

layered materials 60_1-60_4 and an outer area 1145 where the layered materials form thinner layered materials 60_5-60_8 .

[0116] FIG. 15A shows a graph 1250 showing the function of the blowout resistance 1255 of the traction lug 58_i as it varies along line C shown in FIG. 14. In this example, the blowout resistance decreases in successive ones of the materials 60_1-60_8 along the line C. Also, in this example, due to the discrete nature of the zones of different materials 60_1-60_8 , the function of the blowout resistance 1255 still features steps, however the steps are not of equal size.

[0117] A first range 1240 of the graph 1250 represents the thicker layered materials 60_1-60_4 in the inner area 1140 of the traction lug 58_i . These thicker layered materials 60_1-60_4 do not vary equally. In particular, the two first thicker layered materials $60_1, 60_2$ have a particularly high blowout resistance. Subsequent thicker layered materials $60_3, 60_4$ have approximately the same thickness as the two first thicker layered materials $60_1, 60_2$, but they have lower blowout resistance values. In the inner area 1140, the variation of blowout resistance is not equal amongst the different materials, and the function of the blowout resistance 1255 in this first range 1240 approximates a polynomial function 1260. In this case, the materials of the thicker layered materials 60_1-60_4 have been selected so as to achieve an approximation, according to a selected curve-fitting method, of the polynomial function 1260. In other cases, it may not be necessary or desired to approximate a linear, polynomial, or other function. For example, the materials of the thicker layered materials 60_1-60_4 may simply be selected on the basis of a desired blowout resistance in their respective areas.

[0118] A second range 1245 of the graph 1250 represents the thinner layered materials 60_5-60_8 . These thinner layered materials 60_5-60_8 are in the outer area 1145 of the traction lug 58_i and provide a reduced blowout resistance region. While a lower blowout resistance may be acceptable towards the exterior of the traction lug 58_i , it may be desired to avoid strong discontinuities, that is, large differences, in the blowout resistance of adjacent ones of the zones of different materials 60_1-60_8 . In particular, it may be desired to avoid having a relatively highly blowout resistant material adjacent a relatively non-blowout resistant material to avoid a stress concentration at the interface between these materials, which could lead to cracking or tearing at the interface between these materials. In this example, strong discontinuities are avoided by providing four thinner layered materials 60_5-60_8 varying in blowout resistance from a first value λ_{60-5} that is near the blowout resistance of the adjacent thicker layered material 60_4 gradually to a fourth value λ_{60-8} at the outermost thinner layered material 60_8 . The function of the blowout resistance 1255 in the second range 1245 decreases as a step function with relatively equal steps which approximate a linear function 1265. Again, the function 1255 in the second range 1245 need not have equal-sized steps and may not necessarily approximate a linear or other function.

[0119] In the above example, two areas 1140, 1145 of the traction lug 58_i correspond to two regions 1240, 1245 of the graph approximating different functions. In other examples, a single function (linear, polynomial or other) may be approximated by the entire function of the blowout resistance 1255. For example, if the thicker layered materials 60_1-60_4 have an approximately corresponding step size in the function 1255, the thinner layered materials 60_5-60_8 may

be characterized by variations in blowout resistance yielding step sizes proportional to their thinner area such that the zones of different materials 60_1-60_8 together yield a step function that approximates a straight line.

[0120] In a similar manner to that described above in regard of FIG. 15A, the wear resistance of the traction lug 58_i also varies in function of the distance within the traction lug 58_i . More specifically, a function of the wear resistance of the traction lug 58_i varies along line C shown in FIG. 14. However, contrary to the blowout resistance, in this example, the wear resistance increases in successive ones of the zones of different materials 60_1-60_8 along the line C.

[0121] FIG. 15B shows a graph 1550 showing the function of the wear resistance 1555 of the traction lug 58_i as it varies along line C shown in FIG. 14. In this example, the wear resistance increases in successive ones of the zones of different materials 60_1-60_8 along the line C. Also, in this example, due to the discrete nature of the zones of different materials 60_1-60_8 , the function of the wear resistance 1555 still features steps, however the steps are not of equal size.

[0122] A first range 1540 of the graph 1550 represents the thicker layered materials 60_1-60_4 in the inner area 1140 of the traction lug 58_i . These thicker layered materials 60_1-60_4 do not vary equally. In particular, the two first thicker layered materials 60_1 and 60_2 have a particularly low wear resistance. Subsequent thicker layered materials 60_3 and 60_4 have approximately the same thickness as the two first thicker layered materials 60_1 and 60_2 , but they have significantly higher wear resistance values. In the inner area 1140, the variation of wear resistance is not equal amongst the different zones of different materials 60_1-60_4 , and the function of the wear resistance 1555 in this first range 1540 approximates a polynomial function 1560. In this case, the materials of the thicker layered materials 60_1-60_4 have been selected so as to achieve an approximation, according to a selected curve-fitting method, of the polynomial function 1560. In other cases, it may not be necessary or desired to approximate a linear, polynomial, or other function. For example, the materials of the thicker layered materials 60_1-60_4 may simply be selected on the basis of a desired wear resistance in their respective areas.

[0123] A second range 1545 of the graph 1550 represents the thinner layered materials 60_5-60_8 . These thinner layered materials 60_5-60_8 are in the outer area 1145 of the traction lug 58_i and provide an increased wear resistance region. While a higher wear resistance may be desired towards the exterior of the traction lug 58_i , it may be desired to avoid strong discontinuities, that is, large differences, in the wear resistance of adjacent ones of the zones of different materials 60_1-60_8 . In particular, it may be desired to avoid having a relatively highly wear resistant material adjacent a relatively non-wear resistant material to avoid a stress concentration at the interface between these materials, which could lead to cracking or tearing at the interface between these materials. In this example, strong discontinuities are avoided by providing four thinner layered materials 60_5-60_8 varying in wear resistance from a first value β_{60-5} that is near the wear resistance of the adjacent thicker layered material 60_4 gradually to a fourth value β_{60-8} at the outermost thinner layered material 60_8 . The function of the wear resistance 1555 in the second range 1545 increases as a step function with relatively equal steps which approximate a linear function 1565.

Again, the function **1555** in the second range **1545** need not have equal-sized steps and may not necessarily approximate a linear or other function.

[0124] In the above examples, two areas **1140**, **1145** of the traction lug **58_i**, correspond to two regions of each of the graphs **1250**, **1550** approximating different functions. In other examples, a single function (linear, polynomial or other) may be approximated by the entire function of the blowout resistance **1255** or the wear resistance **1555**. For example, if the thicker layered materials **60₁-60₄** have an approximately corresponding step size in the function **1255**, the thinner layered materials **60₅-60₈** may be characterized by variations in blowout resistance yielding step sizes proportional to their thinner area such that the zones of different materials **60₁-60₈** together yield a step function that approximates a straight line. Likewise, if the thicker layered materials **60₁-60₄** have an approximately corresponding step size in the function **1555**, the thinner layered materials **60₅-60₈** may be characterized by variations in wear resistance yielding step sizes proportional to their thinner area such that the zones of different materials **60₁-60₈** together yield a step function that approximates a straight line.

[0125] Fewer zones of different materials **60₁-60_Z** may be provided to reduce the complexity or cost of manufacture of the traction lug **58_i**, (e.g., certain ones of the thicker or thinner layered materials may be omitted).

[0126] In some of the embodiments considered above, the zones of different materials **60₁-60_Z** are layered materials disposed on all sides of the traction lug **58₁**. In other embodiments, the layered materials may be provided only on one part of the traction lug **58_i**, such as for example only on one side thereof. Also, in other embodiments, the zones of different materials **60₁-60_Z** may take forms other than layers (e.g., blocks, bars or plates).

[0127] Individual ones of the discrete zones of different materials **60₁-60_Z** defining a discrete gradient of blowout resistance and wear resistance, such as those considered in the embodiments discussed above, may be provided in various ways.

[0128] For example, in some embodiments, individual ones of the zones of different materials **60₁-60_Z** may be separate amounts of material which are provided separated and interconnected together. This may be done in various ways using various manufacturing processes. For instance, various molding processes may be used to make the traction lug **58_i**, with its arrangement of zones of different materials **60₁-60_Z**. For example, in some embodiments, a compression molding process may be used in which different pieces of material, which are to ultimately form the zones of different materials **60₁-60_Z**, may be placed in a mold such that, after molding, they form the arrangement of zones of different materials **60₁-60_Z**. As another example, in other embodiments, an injection molding process may be used in which amounts of different materials which are to ultimately form the zones of different materials **60₁-60_Z**, may be placed in a mold such that, after molding, they form the arrangement of zones of different materials **60₁-60_Z**.

[0129] Interconnection of the zones of different materials **60₁-60_Z** of the traction lug **58_i** may be effected in various ways.

[0130] For instance, in some embodiments, adjacent ones of the zones of different materials **60₁-60_Z** may be adhesively bonded using an adhesive between them. In some cases, these zones of different materials may be created by

individually molding each of them prior to gluing them together. Alternatively, in some cases, and particularly if the materials are layered materials, the zones of different materials may be created by cutting or otherwise machining them out of a substrate prior to gluing them together. Any suitable adhesive may be used. For instance, in some cases, various commercially-available adhesives (e.g., Chemlok™ adhesives) may be used to adhesively bond adjacent different materials (e.g., rubber/metal using a Chemlok™ 253X adhesive, polyurethane/rubber using a Chemlok™ 213 adhesive, polyurethane/metal using a Chemlok™ 213 adhesive, etc.). In other cases, proprietary adhesives may be used.

[0131] In other embodiments, adjacent ones of the zones of different materials **60₁-60_Z** may be chemically bonded to one another. That is, a chemical bond may be formed between these adjacent materials during manufacturing of the traction lug **58_i**. The materials of these zones of different materials may thus be bonded to one another without any adhesive. Chemical bonding between materials implies an additional constraint to be considered when selecting the materials for the zones of different materials **60₁-60_Z** of the traction lug **58_i**, namely the intercompatibility of the materials. In particular, the materials used in adjacent zones of different materials must be capable of bonding to one another under the right conditions. The conditions must then be applied to ensure that bonding takes place. For example, in some embodiments, one type of rubber may chemically bond with another type of rubber, UHMW may chemically bond with rubber, TPO may chemically bond with rubber, etc.

[0132] There are several ways of creating the traction lug **58_i** with adjacent ones of the zones of different materials **60₁-60_Z** that are chemically bonded. For instance, in some embodiments, a mold having removable portions corresponding to the various materials may be first filled with a first material, then have one or more removable portions removed, then subsequently filled (in the resulting cavities) with a second material, and so on until every zone of the zones of different materials **60₁-60_Z** is filled. In other embodiments, a first mold can be used to form a first material **60₁** of the traction lug **58_i**, the resulting structure being removed from the mold and laced into another mold for forming a second material **60₂** of the traction lug **58_i**, and so forth for every material. In other embodiments, several different materials may be simultaneously injected into a given mold to form adjacent zones of different materials **60₁-60_Z** of the traction lug **58_i**. In yet other embodiments, pieces of different materials, which will eventually make up respective ones of the zones of different materials **60₁-60_Z** are prepared in advance, for instance by molding them or by cutting or otherwise machining them out of a substrate. The pieces are then arranged in their appropriate order and relative positions, and the overall arrangement may be consolidated, for instance by placing it in a heated mold until chemical bonding takes place. If rubber is used, different rubber pieces, such as strips for layered materials, may be vulcanized while together while arranged in their proper relative positions/order, such as to form the traction lug **58_i**, having different zones of different materials that are chemically bonded together. The pieces need not be all arranged and bonded together at once. For instance, if different temperatures are required to cause bonding between different materials, the process may first be applied to the zones of different materials having the highest bonding tempera-

ture prior and subsequently applied to the zones of different materials having lower bonding temperatures.

[0133] The above-described examples of techniques may be combined together to form certain ones of the zones of different materials 60_1 - 60_z of the traction lug 58_i using one technique and other ones of these zones of different materials 60_1 - 60_z using another technique.

[0134] Instead of, or in addition to, being adhesively or chemically bonded together, in some embodiments, adjacent ones of the zones of different materials 60_1 - 60_z of the traction lug 58_i may be mechanically interlocked. That is, a material 60_i and a material 60_j adjacent to the material 60_i may be in a mechanical interlock relationship in which they are interconnected via a given one of the material 60_i and the material 60_j extending into the other one of the material 60_i and the material 60_j . More specifically, a first one of the material 60_i and the material 60_j comprises an interlocking space into which extends an interlocking portion of a second one of the material 60_i and the material 60_j . The interlocking space may comprise one or more holes, one or more recesses, and/or one or more other hollow areas. This mechanical interlock relationship restrains movement of the material 60_i and the material 60_j relative to one another. Geometric details omitted from many of the embodiments discussed above may be included in the zones of different materials 60_1 - 60_z to implement such a mechanical interlock relationship.

[0135] For example, FIG. 16 shows an embodiment in which the arrangement of zones of different materials 60_1 - 60_z of the traction lug 58_i comprise layered materials 60_2 , 60_3 and a core material 60_1 , where each of the layered materials 60_2 , 60_3 comprises an interlocking protuberance 1720, 1725 (e.g., a ridge) that fits into a corresponding interlocking groove in an adjacent material. Various other mechanical interlocking arrangements are possible in other embodiments.

[0136] Adjacent ones of the zones of different materials 60_1 - 60_z of the traction lug 58_i may be mechanically interlocked in various ways. For example, in some cases, adjacent ones of the zones of different materials 60_1 - 60_z of the traction lug 58_i may be mechanically interlocked by separately creating the different zones of different materials (e.g. by molding separately or cutting or otherwise machining out of a substrate) and then assembling them together such as by snap-fitting them together. In some cases, an adhesive may be applied prior to snap-fitting materials together. As another example, in some cases, adjacent ones of the zones of different materials 60_1 - 60_z of the traction lug 58_i may be mechanically interlocked by being overmolded. Using mechanical interlocking, it is not necessarily required for the materials to chemically bond. As such, overmolding may take place using incompatible materials, that is, materials not susceptible to form chemical bonds together during the overmolding process, or using temperatures or orders of molding not susceptible to cause chemical bonding between the materials. In some cases, it may be desired to have both chemical bonding and mechanical interlocking for increased robustness. In such a case the manners of assembling the materials together may include the methods of forming chemical bonds described above.

[0137] While the above embodiments illustrate examples of making and interconnecting the zones of different materials 60_1 - 60_z of the traction lug 58_i to create the arrangement of zones of different materials 60_1 - 60_z and the desired

variation in blowout resistance and wear resistance, various other techniques may be used in other embodiments to provide the zones of different materials 60_1 - 60_z of the traction lug 58_i . For instance, in some embodiments, a material 60_j may be a coated material provided by painting, depositing, spattering or spraying a coating over another material 60_j . The coating may be a coating of polyurethane, acrylic, or any other suitable material, and may have a thickness of about 1 to 1.5 mil (thousandth(s) of an inch) or any other suitable value.

[0138] Also, any suitable combination of the above techniques for creating the zones of different materials 60_1 - 60_z of the traction lug 58_i may be used. For example, in some embodiments, individual materials on the interior of the traction lug 58_i may be overmolded (e.g., with chemical bonding and/or mechanical interlocking), while an outer protective layer (e.g., a skin or a cap) can be applied overtop the traction lug 58_i and held thereon by adhesive bonding or by mechanical interlocking. Alternatively, a spray-on layer may be provided instead of or additionally to, the protective layer as an outermost layer.

[0139] ii. Continuous Gradient

[0140] In some embodiments, the arrangement of zones of different materials 60_1 - 60_z of the traction lug 58_i may exhibit a continuous gradient of blowout resistance and a continuous gradient of wear resistance. A continuous gradient of blowout resistance or wear resistance is a continuous variation of the blowout resistance or wear resistance in a specified direction across the arrangement of zones of different materials 60_1 - 60_z of the traction lug 58_i . In such embodiments, adjacent ones of the zones of different materials 60_1 - 60_z which define the continuous gradient of blowout resistance or wear resistance are infinitesimal zones. A zone is "infinitesimal" in that it is sufficiently small and has a sufficiently small difference in blowout resistance or wear resistance with an adjacent zone that its dimension along the specified direction of the continuous gradient is not macroscopically measurable.

[0141] For example, FIG. 17 illustrates an example of an embodiment in which the variation of the blowout resistance and wear resistance across the arrangement of zones of different materials 60_1 - 60_z of the traction lug 58_i includes a continuous gradient of blowout resistance and a continuous gradient of wear resistance. In this embodiment, each continuous gradient extends throughout the traction lug 58_i . FIGS. 18A and 18B respectively illustrate a graph of the variation of the blowout resistance and the wear resistance as a function of distance along line D shown in FIG. 17. In this example, the spatial variation of the blowout resistance is a generally linear function 1810. Similarly, the spatial variation of the wear resistance is a generally linear function 1910. Although the linear functions 1810, 1910 are shown as perfectly straight, actual realizations of the continuous gradients of blowout resistance and wear resistance in some embodiments may not be perfect and imperfections may result in the variations not being perfectly linear.

[0142] In FIG. 17, certain materials 60_1 - 60_M of the arrangement of zones of different materials 60_1 - 60_z defining the continuous gradients of blowout resistance and wear resistance are represented. The materials 60_1 - 60_m are represented as isolines, where each isoline links points at which the value of the blowout resistance is the same and the value of the wear resistance is the same. The space between adjacent zones of different materials 60_1 , 60_1 includes other

ones of the infinitesimal zones of different materials 60_1-60_z defining the continuous gradients of blowout resistance and wear resistance.

[0143] A continuous gradient of blowout resistance and/or wear resistance may be configured in various other ways in other embodiments. For example, although in the above embodiment it is a linear function, the spatial variation of the blowout resistance defining the continuous gradient may be a more complex function (e.g., a polynomial function) in other embodiments. As another example, while in the above embodiment it extends throughout the entire traction lug 58_i , the continuous gradients of blowout resistance and/or wear resistance may only exist in a limited area of the traction lug 58_i .

[0144] Individual ones of the infinitesimal zones of different materials 60_1-60_z defining continuous gradients of blowout resistance and wear resistance, such as those considered in the embodiments discussed above, may be provided in various ways.

[0145] For example, in some embodiments, the value of the blowout resistance or the wear resistance may be related to a mixture of two or more constituents which make up material of the traction lug 58_i . For instance the relative concentration of each of the constituents may determine the blowout resistance or wear resistance of the resulting material. In such a case, any suitable fabrication method that permits gradual variation in the relative concentration of each of the constituents may be used to produce a continuous gradient of blowout resistance and/or wear resistance.

[0146] As an example, in some embodiments, a twin injection molding technique may be used whereby two ingredients are injected into a mold. The relative intensity of the two jets of ingredients may be varied as the mold fills. Alternatively, rather than to vary the intensity of jets injecting the ingredients into the mold, the two jets may be located at different locations of the mold, and the ingredients may be injected in liquefied form into the mold such that they mix between the two jets and form the traction lug 58_i , having a gradual change in relative concentration of the two ingredients varying for almost uniquely a first ingredient near a corresponding first jet location to almost uniquely a second ingredient near a corresponding second jet. As another example, in some embodiments, the traction lug 58_i may be made by taking two or more solid pieces, each made of one of two ingredients, and placing them in relative position and heating them until they melt and mix at their interface.

[0147] While the above examples describe the use of two ingredients to achieve a continuous gradient of blowout resistance and wear resistance, it should be understood that three or more ingredients may be used as well, wherein the relative concentration of the three or more ingredients determines the value of a property such as the blowout resistance or wear resistance. In some cases, not all ingredients need to be present throughout the traction lug 58_i , since one ingredient may have a concentration of 0% in some areas. As such, in a three-or-more-ingredient scheme, there may be a variation of the relative concentration of two ingredients, followed by a variation of the relative concentration of two other ingredients (including, or not, a common ingredient with the first variation). Any other schemes for combining ingredients in varying relative concentration may be used to achieve a desired variation in blowout resistance or wear resistance.

[0148] As another example, in some embodiments, two or more zones of the arrangement of zones of different materials 60_1-60_z may be formed by subjecting a common base material to a treatment causing at least two areas of the common base material to become different from one another, thus constituting two zones of different materials.

[0149] For instance, in some embodiments, a continuous gradient of blowout resistance or wear resistance may be achieved by a controlled heat treatment. For example, in some cases, an injection molding process may be used in which a rubber to make the traction lug 58_i is injected into a mold at a high temperature and, as the molding process progresses, the temperature may be reduced to cause a smooth variation in the blowout resistance or wear resistance. Other heat treatments may be used in other cases.

[0150] As another example, in some embodiments, a continuous gradient of blowout resistance or wear resistance may be achieved by providing a traction lug 58_i made of a single base material which is altered by applying a penetrating treatment such that the alteration induces a smooth change in the blowout resistance. For instance, in some cases, a material from which to make the traction lug 58_i may be radiated with a certain penetrating (e.g. UV) radiation that causes a change in the material characteristics and that diminishes in intensity with depth. In other cases, an additive or impurity may be added to a material from which to make the traction lug 58_i , from the outside in. Thus, the additive or impurity may penetrate the material to a certain depth dropping in intensity as the depth is increased. This method can be combined with another penetrating treatment, such as heat application. For example, by applying sulfur (or a peroxide, or a urethane crosslinker, or a metal oxide), or another additive to the exterior of a material from which to make the traction lug 58_i , and applying heat thereto as well, the body may be made to have different levels of vulcanization at different depths, resulting in a variation of one or more properties with depth.

[0151] While a penetrating treatment may be applied to a single material, in some cases, multiple materials may be subjected to the penetrating treatment. For example, different materials having different sensitivity to the penetrating treatment may be provided at different depths to modify the effective area over which the penetrating treatment is effective and/or to alter the effect of the penetrating treatment. Alternatively or additionally, materials having a different reaction to the penetrating treatment may be placed in different locations within the traction lug 58_i , so as to provide areas characterized by different gradients of a same or a different property.

[0152] As another example, in some embodiments, a continuous gradient of blowout resistance may be achieved by providing a large number of thin layers each of which differs from its neighbors by a small change in blowout resistance. This may result in a step function with a very fine granularity resembling a smooth function. By heating the thin layers, certain effects may take place at the layers' interfaces which may cause a smoothing of the step function. For instance, in some cases, when heated to a certain temperature (e.g., at or near a melting point of a material making up a layer), adjacent layers may intermix at their interface which may cause a smoothing of the step function of property variation, material from one layer may diffuse into that of another layer, and/or material from one layer may form cross-links with that of another layer.

[0153] iii. Discrete Gradient and Continuous Gradient

[0154] In some embodiments, the variation in blowout resistance and wear resistance defined by the arrangement of zones of different materials 60_1 - 60_z of the traction lug 58_i may include at least one discrete gradient of blowout resistance and wear resistance, and at least one continuous gradient of blowout resistance and wear resistance. Certain ones of the zones of different materials 60_1 - 60_z of the traction lug 58_i may be discrete zones that define a discrete gradient, while other ones of the zones of different materials 60_1 - 60_z may be infinitesimal zones of different materials 60_1 - 60_z that define a continuous gradient.

[0155] For instance, FIG. 19 illustrates an example of such an embodiment, where the zones of different materials 60_1 - 60_z of the traction lug 58_i define an internal area 1410 and an external area 1415. The internal area 1410 defines a continuous gradient of blowout resistance and wear resistance, wherein the blowout resistance decreases along line E and the wear resistance increases along line E.

[0156] Various other combinations of discrete gradients and continuous gradients are possible in other embodiments (e.g., an outer spray-on or sheet layer with a continuous gradient in a remainder of the traction lug 58_i).

[0157] iv. Characterization of Variation in Blowout Resistance and Wear Resistance

[0158] The variation in blowout resistance and wear resistance defined by arrangement of zones of different materials 60_1 - 60_z of a traction lug 48_i may be characterized in various ways.

[0159] For example, a ratio λ_i/λ_j of the blowout resistance λ_i of a material 60_i and the blowout resistance λ_j of another material 60_j that is less resistant to blowout than the material 60_i may take on various values. The blowout resistance of each of the materials 60_i , 60_j may be measured by subjecting a sample of that material to a test as described above and measuring one or more parameters indicative of its blowout resistance, such as its blowout time B and/or its blowout temperature T_b (e.g., under ASTM D-623 conditions). For instance, in some embodiments, a ratio B_i/B_j of the blowout time of the material 60_i over the blowout time of the material 60_j may be at least 2, in some cases at least 3, in some cases at least 4, in some cases at least 5, in some cases at least 10, in some cases at least 15, and in some cases even more (e.g., at least 20, 30 or 40). Alternatively or additionally, in some embodiments, a ratio T_{b-i}/T_{b-j} of the blowout temperature T_{b-i} of the material 60_i over the blowout temperature T_{b-j} of the material 60_j may be at least 1.1, in some cases at least 1.2, in some cases at least 1.3, in some cases at least 1.4, in some cases at least 1.5, in some cases at least 1.6, and in some cases even more (e.g., at least 2). By way of example, in the embodiment of FIG. 11, the ratio B_2/B_1 of the blowout time B_2 of the inner material 60_2 and the blowout time B_1 of the outer material 60_1 of the traction lug 48_i may be at least 2, in some cases at least 3, in some cases at least 4, in some cases at least 5, in some cases at least 10, in some cases at least 15, and in some cases even more (e.g., at least 20, 30 or 40), and/or the ratio T_{b-2}/T_{b-1} of the blowout temperature T_{b-2} of the inner material 60_2 over the blowout temperature T_{b-1} of the outer material 60_1 may be at least 1.1, in some cases at least 1.2, in some cases at least 1.3, in some cases at least 1.4, in some cases at least 1.5, in some cases at least 1.6, in some cases at least 1.7, and in some cases even more (e.g., at least 2).

[0160] As another example, a ratio A_j/A_i of the wear resistance A_j of a material 60_j and the wear resistance A_i of another material 60_i that is less resistant to wear than the material 60_j may take on various values. The wear resistance of each of the materials 60_i , 60_j may be measured by subjecting a sample of that material to a test as described above and measuring one or more parameters indicative of its wear resistance, such as its abrasion resistance (e.g., under ASTM D-5963 conditions). For instance, in some embodiments, where each of the wear resistance A_j of the material 60_j and the wear resistance A_i of the material 60_i is its abrasion resistance expressed as a volumetric loss, the ratio A_j/A_i may be no more than 0.9, in some cases no more than 0.8, in some cases no more than 0.7, in some cases no more than 0.6, in some cases no more than 0.5, and in some cases even less (e.g., no more than 0.4). By way of example, in the embodiment of FIG. 11, the ratio A_1/A_2 of the abrasion resistance A_1 of the outer material 60_1 and the abrasion resistance A_2 of the inner material 60_2 of the traction lug 48_i may be no more than 0.9, in some cases no more than 0.8, in some cases no more than 0.7, in some cases no more than 0.6, in some cases no more than 0.5, and in some cases even less (e.g., no more than 0.4).

[0161] As yet another example, in some embodiments, a size of one or more of the zones of different materials 60_1 - 60_z of the traction lug 58_i may be considered. For instance, in some cases, a first one of the zones of different materials 60_1 - 60_z that is more inward than a second one of the zones of different materials 60_1 - 60_z may be thicker than the second one of the zones of different materials 60_1 - 60_z .

[0162] For instance, an example of such an embodiment is shown in FIG. 14 where each of the inner zones 60_3 , 60_4 is thicker than the outermost zone 60_8 or the mid zone 60_5 . In some examples, an innermost one of the zones of different materials 60_1 - 60_z may be a thickest one of the zones of different materials 60_1 - 60_z .

[0163] Although in embodiments discussed above the arrangement of zones of different materials 60_1 - 60_z exhibits a variation of the blowout resistance and the wear resistance across the traction lug 58_i , in other embodiments, the arrangement of zones of different materials 60_1 - 60_z may exhibit a variation of one or more other material properties in addition to a variation of the blowout resistance and the wear resistance.

[0164] For example, in some embodiments, there may be a variation of a modulus of elasticity across the arrangement of zones of different materials 60_1 - 60_z . For instance, in some cases, the modulus of elasticity may increase inwardly. For example, in some cases, an outer material 60_y of the traction lug 58_i may have a lower modulus of elasticity (i.e., higher elasticity) than an inner material 60_x of the traction lug 58_i . Due to the low modulus of elasticity near the periphery of the traction lug 58_i , compressive forces applied on the traction lug 58_i on the ground may be absorbed by elastic deformation of the traction lug 58_i near its exterior by the higher elasticity of the material of the traction lug 58_i near its exterior. This may help to prevent or at least impede crack propagation within the traction lug 58_i . While absorption of the impact and/or compressive forces applied to the traction lug 58_i may reduce cracking potential, excessive deformation of the traction lug 58_i may cause excessive strain on the traction lug 58_i that may lead to other problems, including blowout. The higher modulus of elasticity of the material deeper within the traction lug 58_i serves to rigidify the

traction lug 58_i , and thus prevent excessive deformation thereof. This may therefore help to prevent or at least impede cracking and/or other negative effects.

[0165] As another example, in some embodiments, there may be a variation of a tensile strength across the arrangement of zones of different materials 60_1 - 60_z . For instance, in some cases, the variation of the tensile strength may include an increase of the tensile strength inwardly such that a material 60_j is more inward and has a greater tensile strength than another material 60_i . In other cases, the variation of the tensile strength may include an increase of the tensile strength outwardly such that a material 60_j is more outward and has a greater tensile strength than another material 60_i .

[0166] As another example, in some embodiments, there may be a variation of a crack propagation resistance across the arrangement of zones of different materials 60_1 - 60_z . The crack propagation resistance of a material 60_x , which can also be referred to a crack growth resistance, refers to a resistance of that material to crack propagation. For example, the crack propagation resistance of the material 60_x can be evaluated on a basis of a crack growth rate (e.g., in mm per number of cycles) measured using a suitable crack growth test (e.g., a pure-shear crack growth test) on the material 60_x , such that the crack propagation resistance is inversely related to the crack growth rate (i.e., the lower the crack growth rate, the higher the crack propagation resistance). For instance, in some cases, the variation of the crack propagation resistance may include an increase of the crack propagation resistance outwardly such that a material 60_j is more outward and has a greater crack propagation resistance (i.e., a lower crack growth rate) than another material 60_i . In other cases, the variation of the crack propagation resistance may include an increase of the crack propagation resistance inwardly such that a material 60_j is more inward and has a greater crack propagation resistance (i.e., a lower crack growth rate) than another material 60_i .

[0167] Principles discussed above in respect of the variation of blowout resistance and wear resistance may therefore also apply to a desired variation of another material property. For instance, the examples of property variation characterization discussed above in respect of the blowout resistance λ or the wear resistance A can be expressed in terms of any desired material property P .

[0168] In some embodiments, with additional reference to FIG. 20, in addition to or instead of enhancing the blowout resistance of the traction lugs 58_1 - 58_T , as described above, the agricultural vehicle 10 may comprise a blowout protection system 90 to protect the track 22 against blowout of the traction lugs 58_1 - 58_T . The blowout protection system 90 is configured to monitor the track 22 and act in respect of a potential occurrence of blowout of one or more of the traction lugs 58_1 - 58_T , such as by providing information (e.g., a warning) regarding the potential occurrence of blowout of one or more of the traction lugs 58_1 - 58_T to the operator of the vehicle 10 or another individual who may take remedial action (e.g., stop or slow down the vehicle 10) and/or by automatically altering an operational state of the vehicle 10 (e.g., a speed of the vehicle 10 such as to stop or slow down the vehicle 10), before one or more of the traction lugs 58_1 - 58_T actually blowout.

[0169] More particularly, in this embodiment, the blowout protection system 90 comprises a blowout sensor 92 for monitoring the track 22 and a processing apparatus 96

connected to the sensor 92 and configured to issue a signal regarding a potential occurrence of blowout of one or more of the traction lugs 58_1 - 58_T .

[0170] The sensor 92 is operable to sense a temperature or other physical characteristic of the track 22 that can be used to assess whether a blowout event is impending. To this end, in this embodiment, the sensor 92 is a temperature sensor to sense a temperature of the track 22. For instance, in various embodiments, the sensor 92 may include a thermistor, a thermocouple, a resistance temperature detector, or an infrared sensor. The sensor 92 may be any other suitable type of sensor in other embodiments to sense another physical characteristic of the track 22 that can be used to assess whether a blowout event is impending (e.g., a pressure sensor to sense a pressure within one or more of the traction lugs 58_1 - 58_T).

[0171] In some embodiments, the sensor 92 may be incorporated into the track 22. For example, in some embodiments, with additional reference to FIG. 21, the sensor 92 may comprise a plurality of sensing elements 93_1 - 93_S in respective ones of the traction lugs 58_1 - 58_T . As such, the temperature may be assessed at respective ones of the traction lugs 58_1 - 58_T .

[0172] In other embodiments, the sensor 92 may be external to the track 22. For instance, in some embodiments, the sensor 92 may be an infrared sensor operable to measure infrared light radiating from the track 22. In one example of implementation, the infrared sensor may be installed on the track-engaging assembly 21 such that it is able to measure the infrared light, and thus heat energy, emitted by the track 22.

[0173] The sensor 92 and the processing apparatus 96 may be connected in any suitable way. For example, in some embodiments, the sensor 92 and the processing apparatus 96 may be connected wirelessly. For instance, the sensor 92 may include a wireless transmitter that can wirelessly exchange data with a wireless receiver of the processing apparatus 96. In other embodiments, the sensor 92 and the processing apparatus 96 may be connected by a wire (e.g., the sensor 92 and the processing apparatus 96 may be separate devices connected by a cable or may be housed in a housing of a common device).

[0174] As shown in FIG. 22, the processing apparatus 96 comprises suitable hardware and/or software configured to implement functionality of the processing apparatus 96. In this embodiment, the processing apparatus 96 comprises an interface 1620, a processing portion 1640, and a memory portion 1660.

[0175] The interface 1620 comprises one or more inputs and outputs allowing the processing apparatus 96 to receive signals from and send signals to other components to which the processing apparatus 96 is connected (i.e., directly or indirectly connected).

[0176] The processing portion 1640 comprises one or more processors for performing processing operations that implement functionality of the processing apparatus 96. A processor of the processing portion 1640 may be a general-purpose processor executing program code stored in the memory portion 1660. Alternatively, a processor of the processing portion 1640 may be a specific-purpose processor comprising one or more preprogrammed hardware or firmware elements (e.g., application-specific integrated circuits (ASICs), electrically erasable programmable read-only memories (EEPROMs), etc.) or other related elements.

[0177] The memory portion 1660 comprises one or more memories for storing program code executed by the processing portion 1640 and/or data used during operation of the processing portion 1640. A memory of the memory portion 1660 may be a semiconductor medium (including, e.g., a solid-state memory), a magnetic storage medium, an optical storage medium, and/or any other suitable type of memory. A memory of the memory portion 1660 may be read-only memory (ROM) and/or random-access memory (RAM), for example.

[0178] The processing apparatus 96 may be implemented in various other ways in other embodiments.

[0179] In some embodiments, two or more elements of the processing apparatus 96 may be implemented by devices that are physically distinct from one another and may be connected to one another via a bus (e.g., one or more electrical conductors or any other suitable bus) or via a communication link which may be wired, wireless, or both. In other embodiments, two or more elements of the processing apparatus 96 may be implemented by a single device.

[0180] With additional reference to FIG. 23, a signal issued by the processing apparatus 96 may be directed to an output device 98 for outputting information regarding a potential occurrence of blowout of the traction lugs 58₁-58_T.

[0181] The output device 98 may be implemented in various ways. For example, with additional reference to FIG. 24, in some embodiments, the output device 98 may comprise a display 100 that is part of the user interface of the operator cabin 20. The information regarding a potential occurrence of blowout of the traction lugs 58₁-58_T may thus be outputted as visual information on the display 100.

[0182] In some embodiments, the display 100 may present visual information that is continually provided. For instance, the display 100 may comprise a parameter reading 106 for indicating a physical quantity related to a potential occurrence of blowout of the traction lugs 58₁-58_T. The parameter reading 106 is continually provided in that it is repeatedly updated to reflect a new parameter reading of the traction lugs 58₁-58_T. In this example, the parameter reading 106 is a temperature reading 106 which indicates an average temperature of the traction lugs 58₁-58_T. The temperature reading 106 may alternatively or additionally indicate a temperature of respective ones of the traction lugs 58₁-58_T. In other embodiments, the parameter reading 106 may be any other suitable type of parameter reading (e.g., a pressure reading).

[0183] Furthermore, in some embodiments, the display 100 may be operable to display a notification 110 to notify the operator when potential occurrence of blowout of one or more of the traction lugs 58₁-58_T is deemed to be impending. For example, the notification 110, which in FIG. 24 is illustrated as a “B”, may be displayed on the display 100 when the sensor 92 detects a temperature or other physical characteristic indicative of potential blowout of one or more of the traction lugs 58₁-58_T. In some embodiments, the display 100 may also be operable to display textual information 108 to inform the operator of any impending blowout occurrence. For example, the textual information 108 may read “blowout danger” to indicate a potential impending blowout occurrence or it may simply read “OK” to indicate that there is no potential impending blowout occurrence.

[0184] In some embodiments, the display 100 may also present graphical information 112 for notifying the operator when potential occurrence of blowout of one or more of the traction lugs 58₁-58_T is deemed to be impending. For instance, the graphical information 112 may include a color coded indicator with different colors attributed different meanings. For instance, the graphical information 112 may include a green indicator, an orange indicator and a red indicator (represented as “G”, “O” and “R” in FIG. 24) each of which is indicative of a condition of the traction lugs 58₁-58_T. In this case, the green indicator indicates that the traction lugs 58₁-58_T are in an acceptable condition, the orange indicator indicates that the traction lugs 58₁-58_T are beginning to show signs of potential blowout occurrence and the red indicator indicates that the traction lugs 58₁-58_T are in danger of blowing out. In order to assess the condition the traction lugs 58₁-58_T are in such as to be able to notify the operator of the condition via the graphical information 112, the processing apparatus 96 may implement a process which is further described below.

[0185] In other embodiments, the visual information indicating potential impending blowout of the traction lugs may simply be implemented by a light indicator on the control panel of the operator cabin 20. For example, the light indicator may turn on when it is considered that potential blowout is impending and may turn off when it is considered that there is no danger of blowout of the traction lugs 58₁-58_T.

[0186] In addition or alternatively to providing visual information, in some embodiments, the output device 98 may be operable to provide audible information to the operator of the vehicle 10. For instance, with additional reference to FIG. 25, in some embodiments, the output device 98 may comprise a speaker 104 for emitting sound indicative of the state of the traction lugs 58₁-58_T. For example, the speaker 104 may communicate through an automated voice that the traction lugs 58₁-58_T are in danger of blowing out (e.g., “caution: blowout impending”). In other cases, the speaker 104 may simply emit a distinctive noise (e.g., an alert) indicative of an impending blowout of the traction lugs 58₁-58_T.

[0187] The information regarding a potential occurrence of blowout of the traction lugs 58₁-58_T may be derived by comparing measured temperatures acquired through the sensor 92 to reference temperature data. For example, this may be the case where the information to be displayed is indicative of a condition of the traction lugs 58₁-58_T such as when displaying the graphical information 112 or issuing the visual notification 110 or the audible notification through the speaker 104. To this end, the processing apparatus 96 may have access to the reference temperature data (e.g., stored in the memory portion 1660) from which the condition of the traction lugs 58₁-58_T in respect of potential blowout occurrence may be derived. More specifically, the reference temperature data may define temperature ranges associated with a condition of the traction lugs 58₁-58_T. For example, an “acceptable condition” may be defined by a temperature range including all temperatures below an accepted temperature T_A . The accepted temperature T_A may be a temperature below which there is considered to be no danger for blowout for example. A “caution condition” may be defined by a temperature range between the accepted temperature T_A and a blowout temperature T_B . The blowout temperature T_B may be a temperature above which blowout of the traction

lugs is considered imminent. Lastly, a “danger condition” may be defined by a temperature range including all temperatures above the blowout temperature T_B . Although three possible conditions were described (e.g., accepted, caution and danger), in some cases, more or less conditions may be identified.

[0188] In some embodiments, with additional reference to FIG. 26, a signal issued by the processing apparatus 96 may be directed to a powertrain (e.g., the prime mover 14) of the vehicle 10 for altering an operational state of the vehicle 10. For example, the signal issued may be configured to control the engine or hydraulic drive system of the vehicle 10 to reduce the speed of the vehicle 10, in order to stop it and/or to slow it down. For instance, if the processing apparatus 96 establishes that the traction lugs 58₁-58_T are in the “danger condition” as defined above, the signal issued by the processing apparatus 96 may control the engine of the vehicle 10 or any other component of the powertrain to slow down the vehicle 10.

[0189] While they have been described in respect of blowout or other deterioration of the traction lugs 58₁-58_T, in some embodiments, solutions described herein in respect of the traction lugs 58₁-58_T may be similarly applied to the drive/guide lugs 48₁-48_N. For example, in some embodiments, as shown in FIG. 27, a drive/guide lug 48_i may comprise an arrangement of zones of different materials 160₁-160_Z exhibiting a desired variation in blowout resistance and wear resistance, similar to that described above in connection with the arrangement of zones of different materials 60₁-60_Z of a traction lug 58_i. Thus, in this example, the blowout resistance of an inner material 160₁ of the drive/guide lug 48_i is greater than the blowout resistance of an outer material 160₂ of the drive/guide lug 48_i, and the wear resistance of the outer material 160₂ of the drive/guide lug 48_i is greater than the wear resistance of the inner material 160₁ of the drive/guide lug 48_i.

[0190] Each track system 16_i of the agricultural vehicle 10, including its track 22, may be configured in various other ways in other embodiments.

[0191] For example, each track system 16_i may comprise different and/or additional components in other embodiments. For example, in some embodiments, the track system 16_i may comprise a front drive wheel (e.g., the idler wheel 26 may be replaced by a drive wheel) instead of or in addition to the drive wheel 24. As another example, in some embodiments, the track system 16_i may comprise more or less roller wheels such as the roller wheels 28₁-28₆. As yet another example, rather than have a generally linear configuration as in this embodiment, in other embodiments, the track system 16_i may have various other configurations (e.g., a generally triangular configuration with the axis of rotation of the drive wheel 24 located between the axes of rotations of leading and trailing idler wheels).

[0192] While in the embodiment considered above the off-road vehicle 10 is an agricultural vehicle, in other embodiments, the vehicle 10 may be an industrial vehicle such as a construction vehicle (e.g., a loader, a bulldozer, an excavator, etc.) for performing construction work or a forestry vehicle (e.g., a feller-buncher, a tree chipper, a knuckleboom loader, etc.) for performing forestry work, or a military vehicle (e.g., a combat engineering vehicle (CEV), etc.) for performing military work, or any other vehicle operable off paved roads. Although operable off paved roads, the vehicle 10 may also be operable on paved roads

in some cases. Also, while in the embodiment considered above the vehicle 10 is driven by a human operator in the vehicle 10, in other embodiments, the vehicle 10 may be an unmanned ground vehicle (e.g., a teleoperated or autonomous unmanned ground vehicle).

[0193] In some examples of implementation, any feature of any embodiment described herein may be used in combination with any feature of any other embodiment described herein.

[0194] Certain additional elements that may be needed for operation of some embodiments have not been described or illustrated as they are assumed to be within the purview of those of ordinary skill in the art. Moreover, certain embodiments may be free of, may lack and/or may function without any element that is not specifically disclosed herein.

[0195] Although various embodiments and examples have been presented, this was for the purpose of describing, but not limiting, the invention. Various modifications and enhancements will become apparent to those of ordinary skill in the art and are within the scope of the invention, which is defined by the appended claims.

1.-31. (canceled)

32. A track for traction of a vehicle, the track being mountable around a plurality of wheels that comprises a drive wheel for driving the track, the track being elastomeric to flex around the wheels, the track comprising:

an inner surface for facing the wheels;

a ground-engaging outer surface for engaging the ground; and

a plurality of traction projections projecting from the ground-engaging outer surface and distributed in a longitudinal direction of the track, each traction projection of the plurality of traction projections comprising:

an outer elastomeric material extending to a periphery of the traction projection; and

an inner elastomeric material disposed inwardly of the outer elastomeric material and more resistant to blowout than the outer elastomeric material to prevent blowout of the traction projection during use of the track.

33. The track of claim 32, wherein a blowout time of the inner elastomeric material is greater than a blowout time of the outer elastomeric material under ASTM D-623.

34. The track of claim 33, wherein a ratio of the blowout time of the inner elastomeric material over the blowout time of the outer elastomeric material is at least 2.

35. The track of claim 33, wherein a ratio of the blowout time of the inner elastomeric material over the blowout time of the outer elastomeric material is at least 5.

36. The track of claim 33, wherein a ratio of the blowout time of the inner elastomeric material over the blowout time of the outer elastomeric material is at least 10.

37. The track of claim 32, wherein the inner elastomeric material has a blowout time of at least plural minutes under ASTM D-623.

38. The track of claim 37, wherein the inner elastomeric material has a blowout time of at least fifteen minutes under ASTM D-623.

39. The track of claim 32, wherein a blowout temperature of the inner elastomeric material is greater than a blowout temperature of the outer elastomeric material under ASTM D-623.

40. The track of claim **39**, wherein a ratio of the blowout temperature of the inner elastomeric material over the blowout temperature of the outer elastomeric material is at least 1.3.

41. The track of claim **39**, wherein a ratio of the blowout temperature of the inner elastomeric material over the blowout temperature of the outer elastomeric material is at least 1.5.

42. The track of claim **32**, wherein the outer elastomeric material is more resistant to wear than the inner elastomeric material.

43. The track of claim **42**, wherein an abrasion resistance of the outer elastomeric material is greater than an abrasion resistance of the inner elastomeric material under ASTM D-5963.

44. The track of claim **43**, wherein each of the abrasion resistance of the outer elastomeric material and the abrasion resistance of the inner elastomeric material is expressed as a volumetric loss and a ratio of the abrasion resistance of the inner elastomeric material over the abrasion resistance of the outer elastomeric material is no more than 0.7.

45. The track of claim **43**, wherein each of the abrasion resistance of the outer elastomeric material and the abrasion resistance of the inner elastomeric material is expressed as a volumetric loss and a ratio of the abrasion resistance of the inner elastomeric material over the abrasion resistance of the outer elastomeric material is no more than 0.5.

46. The track of claim **32**, wherein a volumetric loss at the periphery of the traction projection under ASTM D-5963 is no more than 110 mm³.

47. The track of claim **32**, wherein a volumetric loss at the periphery of the traction projection under ASTM D-5963 is no more than 100 mm³.

48. The track of claim **32**, wherein a volumetric loss at the periphery of the traction projection under ASTM D-5963 is no more than 90 mm³.

49. The track of claim **32**, wherein a ratio of a volume of the inner elastomeric material over a volume of the traction projection is at least 0.2.

50. The track of claim **32**, wherein a ratio of a volume of the inner elastomeric material over a volume of the traction projection is at least 0.3.

51. The track of claim **32**, wherein the inner elastomeric material occupies a majority of a volume of the traction projection.

52. The track of claim **51**, wherein a ratio of a volume of the inner elastomeric material over the volume of the traction projection is at least 0.8.

53. The track of claim **32**, wherein a ratio of a dimension of the inner elastomeric material in a thicknesswise direction of the track over a dimension of the traction projection in the thicknesswise direction of the track is at least 0.2.

54. The track of claim **32**, wherein a ratio of a dimension of the inner elastomeric material in a thicknesswise direction of the track over a dimension of the traction projection in the thicknesswise direction of the track is at least 0.3.

55. The track of claim **32**, wherein a dimension of the inner elastomeric material in a thicknesswise direction of the track corresponds to a majority of a dimension of the traction projection in the thicknesswise direction of the track.

56. The track of claim **55**, wherein a ratio of a dimension of the inner elastomeric material in the thicknesswise direction of the track over a dimension of the traction projection in the thicknesswise direction of the track is at least 0.8.

57. The track of claim **32**, wherein a dimension of the inner elastomeric material in a thicknesswise direction of the track is greater than a dimension of the outer elastomeric material in the thicknesswise direction of the track.

58. The track of claim **32**, wherein the inner elastomeric material extends to the periphery of the traction projection and forms a smaller part of the periphery of the traction projection than the outer elastomeric material.

59. The track of claim **32**, wherein: the inner elastomeric material is a first inner elastomeric material; and the traction projection comprises a second inner elastomeric material disposed between and different from the outer elastomeric material and the first inner elastomeric material.

60. A track for traction of a vehicle, the track being mountable around a plurality of wheels that comprises a drive wheel for driving the track, the track being elastomeric to flex around the wheels, the track comprising:

- an inner surface for facing the wheels;
- a ground-engaging outer surface for engaging the ground;
- and

- a plurality of traction projections projecting from the ground-engaging outer surface and distributed in a longitudinal direction of the track, each traction projection of the plurality of traction projections comprising:

- an outer elastomeric material extending to a periphery of the traction projection; and

- an inner elastomeric material disposed inwardly of the outer elastomeric material and having a blowout time of at least plural minutes under ASTM D-623.

61. A track for traction of a vehicle, the track being mountable around a plurality of wheels that comprises a drive wheel for driving the track, the track being elastomeric to flex around the wheels, the track comprising:

- an inner surface for facing the wheels;
- a ground-engaging outer surface for engaging the ground;
- and

- a plurality of traction projections projecting from the ground-engaging outer surface and distributed in a longitudinal direction of the track, each traction projection of the plurality of traction projections comprising:

- an outer elastomeric material extending to a periphery of the traction projection; and

- an inner elastomeric material disposed inwardly of the outer elastomeric material and configured to generate less heat buildup than the outer elastomeric material.

* * * * *