

July 12, 1938.

E. KOLLER

2,123,786

SKI BINDING

Filed Feb. 24, 1937

2 Sheets-Sheet 1

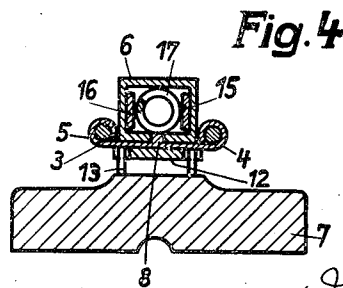
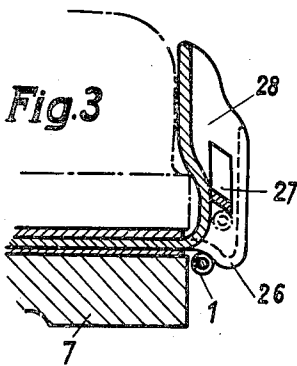
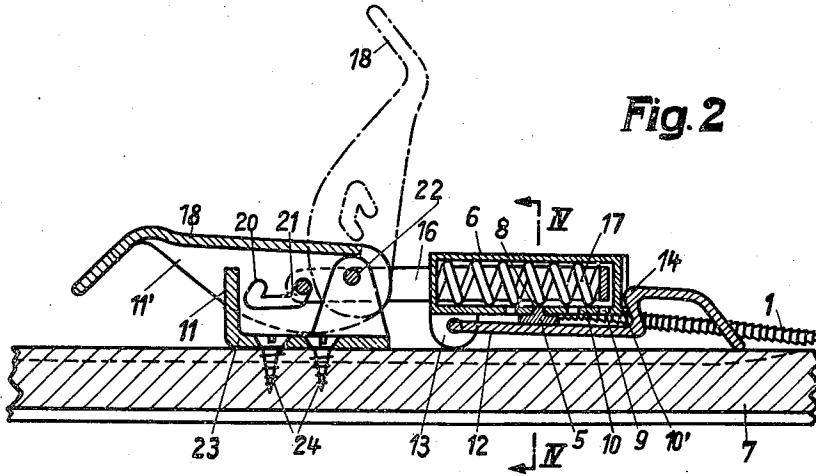
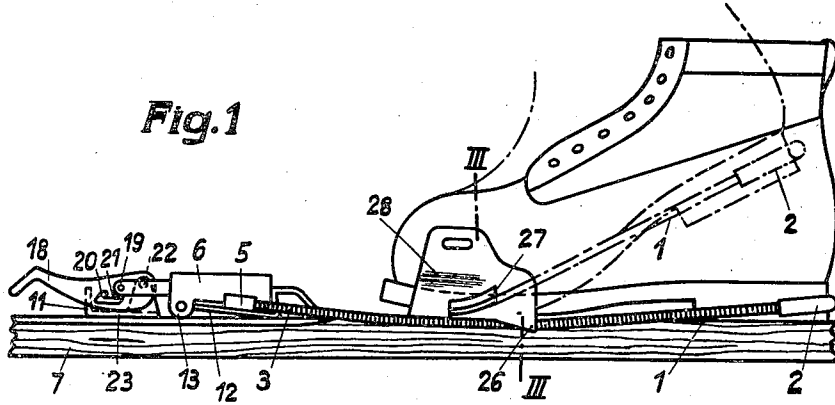

Inventor
Emil Koller
By Binger, atty.

July 12, 1938.

E. KOLLER

2,123,786

SKI BINDING

Filed Feb. 24, 1937

2 Sheets-Sheet 2

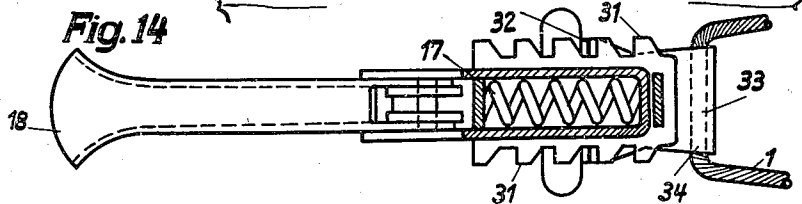
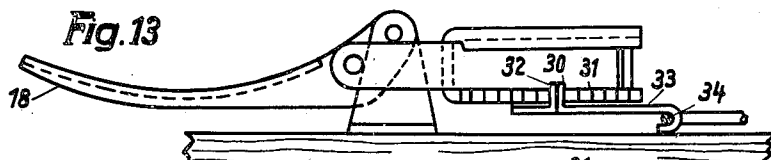
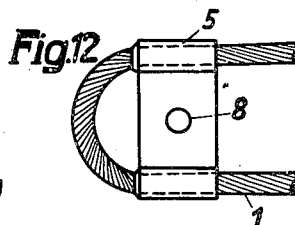
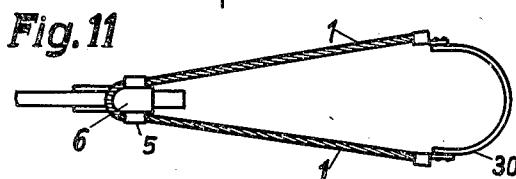
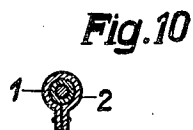
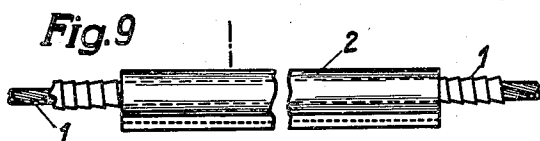
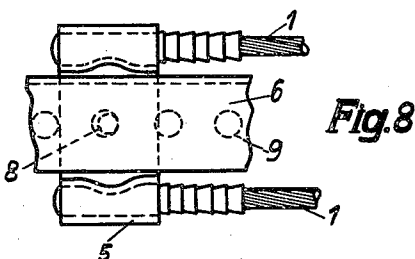
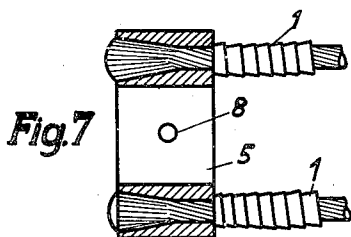
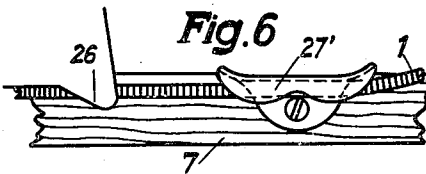
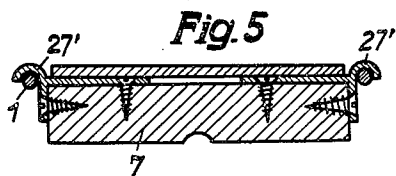

Inventor
Emil Koller
By *B. H. H. H.* atty.

UNITED STATES PATENT OFFICE

2,123,786

SKI BINDING

Emil Koller, Zurich, Switzerland

Application February 24, 1937, Serial No. 127,544
In Germany February 26, 1936

7 Claims. (Cl. 280—11.35)

The present invention relates to a binding for the front portion of a ski combined with a tensioning spring for the heel member.

Bindings are known in which the heel tensioning element, for instance, a cable, is to be set in various notches of a housing which is located in front of the lateral plates at the toes. By shifting the housing longitudinally of the ski through a tensioning member, a more or less strong tension was produced on the heel member. Bindings of this type are limited as to adjustability of the tension. This is a disadvantage, particularly with bindings of that character in which laterally at the cheeks of the ski and at the vertical plates of the toe cheeks, a plurality of supporting points for the heel tensioning element are provided. In all of these cases it is absolutely essential to render the cable loop adjustable without abandoning entirely the resilient feature. It had been attempted heretofore to accomplish this result by disposing in front of the binding a housing with notches holding this housing rigidly in place. This housing then made it possible to adjust the loop of the cable without further trouble. The resilient nature of the binding was then produced by a tensioning member of the Bildstein type positioned about the heel. These tensioning members, however, have the disadvantage that they do not force the boot in accurately axial direction into the space between the toe cheeks, and particularly at that very instant at which they release themselves upon a fall, they impart to the boot and thereby also to the foot within the boot a twisting action which might injure the foot. The general aim, therefore, always has been a resilient mounting in axial direction.

The present invention now provides for wide adjustability and for a very thorough and reliable spring support. This is accomplished, according to the present invention, by the fact that in front of the toe cheeks and upon the back of the ski, a tensioning lever is rotatably mounted. This tensioning lever is pivotally connected eccentrically with a U-shaped bail member. This bail member supports a housing which covers a spring, and the loop of the cable may be hooked into this housing in various positions.

Other objects of my invention and the invention itself will become more apparent from the following description and in which reference will be had to the accompanying drawings illustrating different embodiments of my invention.

Referring to the drawings:

Fig. 1 shows an elevational view of an embodiment of my invention, together with a boot and

a part of a ski to which the embodiment binding is illustrated as applied;

Fig. 2 is a medial sectional view of the stretching device together with fragments of the ski and of the cable;

Figs. 3 and 4 are sections taken on the lines III—III and IV—IV of Figs. 1 and 2 respectively.

Figs. 5 and 6 show additional guides for the cable in sectional view and in side elevation.

Figs. 7, 8 and 12 show the manner of securing the heel cable to a connecting piece by which it hung to the resilient stretching device.

Figs. 9 and 10 are an elevation and a section respectively of a second embodiment of the rolling body which is placed on the heel part of the cable.

Fig. 11 shows in a schematical manner another embodiment of the heel cable.

Figs. 13 and 14 show, respectively, an elevational and a plan view of a second embodiment of the stretching device.

Referring first to the embodiment of my invention illustrated in Figs. 1 to 6 inclusive, the ski binding mechanism of my invention as embodied therein, comprises a pair of oppositely formed toe irons which, at 28 are bent inwardly so as to act as sole fasteners, which prevent the boot inserted into the binding from moving upwardly. The ends 3 and 4 of the cable placed around the heel are secured to a connecting piece 5 whereas the cable is protected by a helically wound wire 1.

The manner of securing the cable to the connecting piece 5 is shown more specifically in the Figs. 7 and 8. Connecting piece 5 is provided with two holes which in their forward end are conical. The opened strands of the cable ends are soldered to piece 5 and as tests have shown this connection is extremely efficient.

A rolling body 2 is arranged on the heel part of the cable, which allows to roll the cable in a simple and convenient way on the heel of the boot provided of course that the stretching device is opened. Rolling body 2 consists preferably of rubber, or of leather as illustrated in Figs. 9 and 10. This auxiliary attachment facilitates the positioning of the cable on the heel. The rubber hose 2, for instance, can simply be rolled up on the heel, whereby a certain pre-tension of the cable is accomplished.

Connecting piece 5 is secured to the stretching device arranged in front of the toe irons by means of a pin 8 which may be placed in one of the several holes 9 of the bottom of casing 6. In order to make the fastening device

suit different sizes of boots and/or to vary the pull exerted by the cable, pin 8 must simply be placed in another of the holes 9. A bottom lever 12 hinged to casing 6 and secured in its position by an edge 14, which projects above the projecting edge 10' of the bottom of the casing 6, secures pin 8 in the hole 9 in which it has been placed. A lever 18 pivotally mounted in a support 23 is provided with several, e. g. two notches 20 and 21, into which a bolt 22 connecting the flanges 15, 16 of a U-shaped arm may be placed. The flanges 15 and 16 of this arm enter casing 6 and are adapted to press the helical spring 17 arranged in the said casing against the front wall of the latter. A pin 19 connects the ends of the straps 15 and 16, and this pin may be inserted into either one of the notches 20, 21 of the tensioning lever 18. According to the pull which is to be applied to the boot by the cable, pin 19 is placed in the suitable notch 20 or 21. The notches 20, 21 are so arranged that when the lever 18 is in its lowered position as shown in Fig. 1 they are located below the level of the pivot pin 22 of the lever 18. The tension put on the cable 1 will therefore act to lock the lever 18.

Support 23 which is secured to the ski 17 by means of wood-screws 24 is provided with a lug 11 projecting upwards and entering lever 18 which is of U-shaped cross-section (see Fig. 4). Lug 11 acts as guide for the vertical walls 11' of lever 18, keeps it in its locked position if it is sufficiently broad so as to be clamped firmly between the walls 11' and prevents grass or other obstacles from raising lever 18. To this effect the forward end of the latter is also inclined downward.

The toe irons are provided with guides for the cable and according to the modifications shown in Figs. 1 and 3, 5 and 6 at least two such guides are provided for. Guides 27 are preferably stamped out of the vertical flanges of the toe irons so that they are inclined forwardly and downwardly so as to efficiently guide the cable 1. Of course the guides 27 might also be welded to the toe irons 28. Another guide for the cable is obtained by giving the base flanges of the toe irons the shape resulting from Fig. 3. As will be seen from this figure the base flanges are provided with a projecting part 26 so that the cable can be effectively guided between projection 26 and the ski.

When going uphill with the ski the cable is placed below guide 27. This position guarantees an ideal paying out of the cable and produces no tiring strain on the foot. For downhill races it is desired to perfectly unit ski and foot. To this end the cable is laid in guide 26 as shown in Figure 3. For touring skiing and combined position might be used: the inside cable of the binding can then be put in guide 27 and the outside cable in guide 26.

As shown in the Figures 5 and 6 a still further guide 27' might be arranged behind the trailing portion of the side plates of the toe irons so as to still more increase the downward or diagonal pull on the cable and the boot. In the modification shown in the Figures 5 and 6 the guides 27' are disposed at the upper edge of the ski. The cable is then more or less on the same level as the sole plate.

Guides 27 can also be obtained by simply securing bolts to the side plates of the toe irons.

Fig. 11 shows a modification according to which a leather strap is inserted in the cable. Such a binding is especially suitable for use by

children. In such a case the ends of cable 1 are not secured to connecting piece 5 in the manner shown in Figs. 7 and 8 but now the ends of the cable are secured to the leather strap 30 whereas the part of the cable in front of connecting piece 5 is laid over the casing 6. Also in this case cable 1 is soldered to connecting piece 5, so as to prevent any mutual movement of these two parts. Such movements near connecting piece 5, where the cable is strongly bent would cause rapid wear and deterioration. Therefore, also when cable 1 is manufactured so as to form one single loop it is nevertheless soldered to connecting piece 5.

The cable might also be directly connected to the stretching lever 18 without interposing a spring between cable and lever. Besides the stretcher 18 a second stretcher of the usual type might be arranged in the heel portion of the cable. It is also possible to dispose a spring in front of the toe irons and the stretcher in the heel portion of the cable.

A last modification of the stretching device is shown in Figures 13 and 14. The only difference lies in another way of securing connecting piece to the spring casing. According to this modification cable 1 is fastened in a hook 33 which is provided with two pairs of resilient lugs 30 and 32 which can be placed in serrations 31 of the bottom of the casing 6. Hook 33 is fitted with a guide bush for the cable.

As may be seen from the drawings the protective layer of helically wound wire around the cable consists of a special wire the profile of which tapers in one direction. Thus a flexible cable is obtained.

Having thus described my invention in several embodiments, I am aware that numerous and extensive departures may be made from the embodiments herein illustrated and described but without departing from the spirit of my invention.

What I wish to claim is:—

1. In skis wherein is provided toe irons to receive a shoe and means to hold the shoe tightly to the toe irons, said means comprising a cable passed around the heel of the shoe and extended along side the shoe to a place in front of the shoe; a cross piece carried by the front extremity of the cable, a casing, means to connect said cross piece to said casing at any one of several points of connection, a U-shaped element in said casing whose arms are projected forwardly through openings in said casing, a pressure spring in the casing continuously urging said U-shaped element inwardly, and a lever device mounted on the ski and connected with said U-shaped element for placing and holding said spring, and thereby said cable, under tension.

2. In skis wherein is provided toe irons to receive a shoe and means to hold the shoe tightly to the toe irons, said means comprising a cable passed around the heel of the shoe and extended along side the shoe to a place in front of the shoe; a cross piece carried by the front extremity of the cable, a casing, means to connect said cross piece to said casing, a U-shaped element in said casing whose arms are projected forwardly through openings in said casing, a pressure spring in the casing continuously urging said U-shaped element inwardly, and a lever device mounted on the ski and connected with said U-shaped element for placing and holding said spring, and thereby said cable, under tension, said connecting means including a clamping lever

pivoted beneath and to the casing, between which lever and the casing said cross-piece is held, said cross-piece having a pin and said casing having a series of pin receiving holes into any of which said pin may be placed.

3. In a ski having a heel engaging cable, means to tension the same, said means comprising a lever fixedly located on the ski, a U-shaped member whose ends are pivoted to the lever, a body having provisions to receive the bend-end of said U-shaped member, a spring in said body continuously tending to force said bend-end inwardly, said body having a series of recesses, a hook to engage said cable and having a projection to enter any one of said recesses and thereby connect said cable and said body whereby when said lever is moved to its active position said spring will be compressed and said cable placed under tension.

4. In a ski having a heel engaging cable, means to tension the same, said means comprising a lever fixedly located on the ski, a U-shaped member whose ends are pivoted to the lever, a body having provisions to receive the bend-end of said U-shaped member, a spring in said body continuously tending to force said bend-end inwardly, said body having at each side a series of toothed notches, a plate having a hook to engage the cable and project under said body and having fingers to engage said notches.

5. In a ski having a heel engaging cable, means to tension the same, said means comprising a lever fixedly located on the ski, a U-shaped member whose ends are pivoted to the lever, a body having provisions to receive the bend-end of said U-shaped member, a spring in said body continuously tending to force said bend-end inwardly, said body having a series of recesses, a hook to engage said cable and having a projection to enter any one of said recesses and thereby connect said cable and said body whereby when said lever is moved to its active position said spring will be compressed and said cable placed

under tension, said cable having a rubber hose portion thereon about the heel portion of the cable loop.

6. In a ski having a pair of oppositely disposed toe irons and a heel engaging cable looped around the heel of a shoe and extended beneath portions of the toe irons to a place in front of the toe irons; means for placing said cable under tension, said means comprising a tension lever and a body connected with said cable, a spring in said body, a U-shaped member on which said body is slidable and which is engaged by said spring for continuously tending to move said body away from said tension lever, the ends of said U-shaped member being connected by a cross pin, said lever having a slot with recesses to receive said pin at different distances from the lever's pivot, said recesses being so located that when said lever is functioning said U-shaped member will lie below the lever's pivot.

7. In a ski having a pair of oppositely disposed toe irons and a heel engaging cable looped around the heel of a shoe and extended beneath portions of the toe irons to a place in front of the toe irons; means for placing said cable under tension, said means comprising a tension lever and a body connected with said cable, a spring in said body, a U-shaped member on which said body is slidable and which is engaged by said spring for continuously tending to move said body away from said tension lever, the ends of said U-shaped member being pivoted to said lever at a place which, when said lever is functioning, will cause said U-shaped member to lie below the lever's pivot, the connections between said body and cable including a cross-piece carried by the cable, to underlie said body, said cross piece and said body having engaging parts, and a lever carried by said body for holding said cross-piece in place, said holding lever being held in place by the tension on the body and cable and engagement of the holding lever with the body of the ski.

EMIL KOLLER.