

G. H. GARRISON.
SEMIFLEXIBLE REAR SIGHT FOR FIREARMS.
APPLICATION FILED JULY 28, 1904.

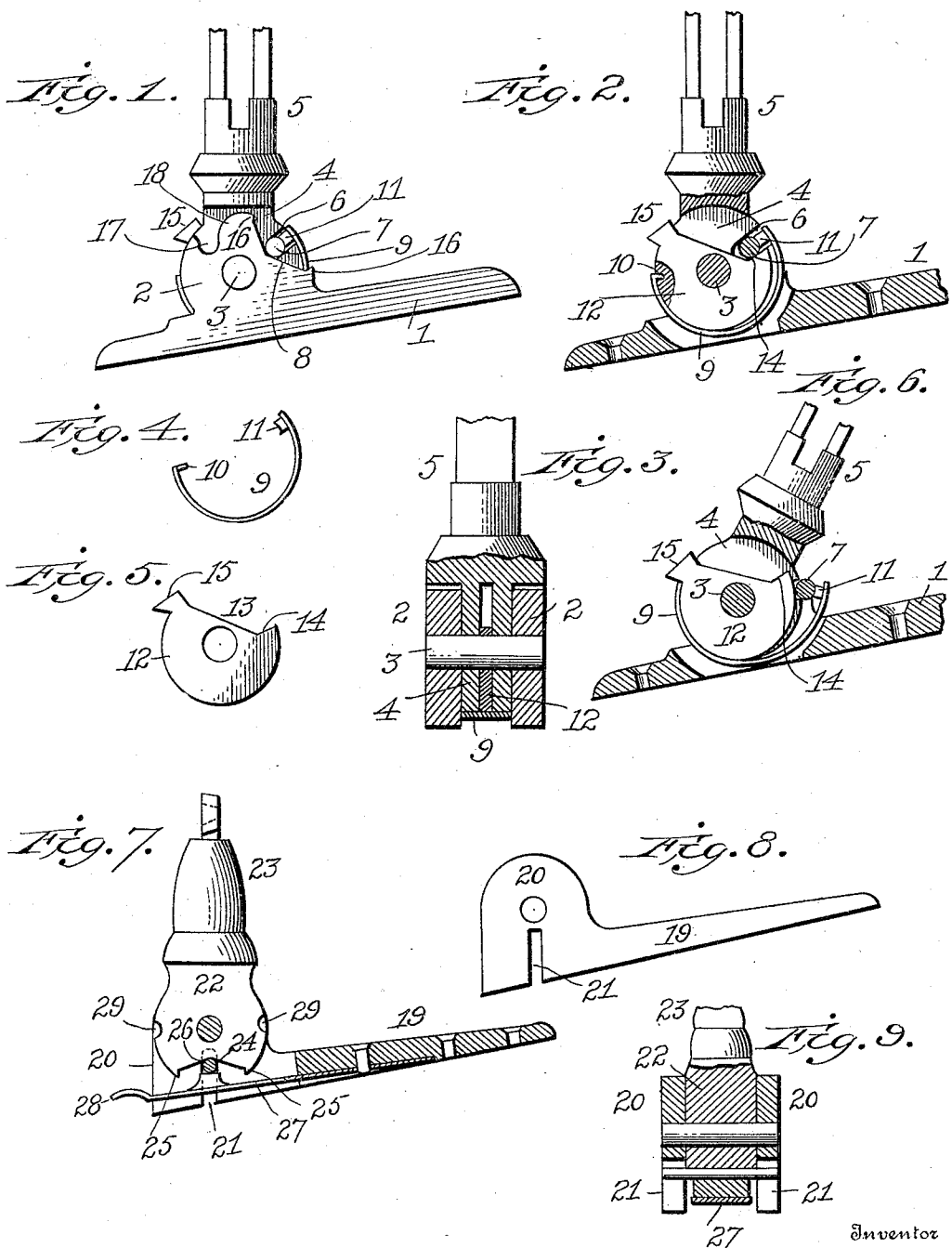

Witnesses
 Edwin L. Yewell
 John M. Tucker

Inventor
 George D. Garrison
 By
 Geo. W. Hinesey
 Attorney

UNITED STATES PATENT OFFICE.

GEORGE H. GARRISON, OF GLADSTONE, MICHIGAN.

SEMIFLEXIBLE REAR SIGHT FOR FIREARMS.

No. 804,805.

Specification of Letters Patent.

Patented Nov. 14, 1905.

Application filed July 28, 1904. Serial No. 218,536.

To all whom it may concern:

Be it known that I, GEORGE H. GARRISON, a citizen of the United States, residing at Gladstone, in the county of Delta and State of Michigan, have invented new and useful Improvements in Semiflexible Rear Sights for Firearms, of which the following is a specification.

This invention relates to rear sights for firearms; and its object is to provide a sight that has a slight degree of flexibility in a forward and backward direction, so that it will yield when struck by a bush or branch or the person of the hunter, but will at once resume its normal position when released.

To this end the invention consists in a sight having the upright hinged to the base and provided with a spring which holds it yieldingly in its upright position. Means are also provided for permitting the upright to be folded down when the sight is not needed.

In the accompanying drawings, Figure 1 is a side elevation of a portion of a rear sight embodying my improvements. Fig. 2 is a vertical section of the same. Fig. 3 is a cross-section thereof. Fig. 4 shows the spring. Fig. 5 shows the dog for holding the pin and the spring out of operative position. Fig. 6 shows the manner in which the dog effects this result. Fig. 7 is a sectional elevation of a modification. Fig. 8 shows the base-plate therefor. Fig. 9 is a cross-section thereof.

Referring first to Figs. 1 to 6, the base-plate 1 has upon it two parallel ears 2, between which is hinged on the pivot 3 the knuckle 4 of the upright 5. In one side of the knuckle is a radial notch 6, in which is a loose transverse pin 7, lying with its axis parallel with the knuckle, so as to engage with the V-shaped cam 8 in each of the ears 2. A flat spring 9 partly encircles the knuckle between the ears, one end of the spring being provided with a flange 10, which enters a suitable notch in the knuckle, while the other end of said spring has a head 11 bearing on the pin 7 and tending to hold it at the bottom of the slot 6. The knuckle is bifurcated, as shown in Fig. 3, to admit a thin circular disk or dog 12, which is pivoted on the pivot 3 and is cut away at 13, so as to avoid any interference with the movement of the pin 7 in the slot 6. At one end of the cut-away portion is a nose 14 and at

the other end a tail 15, the latter projecting beyond the periphery of the knuckle.

The operation is as follows: With the parts standing as shown in Fig. 1, the spring forces the pin to the bottom of the slot, and the pressure of the projecting ends of the pin on the inclined surfaces of the cams 8 causes the pin to ride down to the bottom of the V, and thus determine the normal position of the upright 5. Any deflection of the upright either way from this position forces the pin to ride up one of the inclines and puts the spring under tension, so that the instant the upright is released the spring will urge the pin inward and bring the upright back to its normal position. The deflection of the upright is limited by lips 16 at the ends of the inclines which stop the further movement of the pin.

In case it is desired to fold the upright down upon the base-plate out of the way the upright is deflected to the right until the pin strikes the lower lip 16, which is beyond the edge of the knuckle. In this position the pin is beyond the edge of the dog, so that the latter can be rotated by its tail to bring its nose under the pin, as shown in Fig. 6. The upright can now be turned to the left, and as the pin cannot return into the V-shaped cams it will pass outside of the upper lip 16, which is within the edge of the knuckle, and thus the upright can be folded down to a position parallel with the base-plate. Shortly after the pin has passed the upper lip 16 the tail of the dog will strike the stock of the gun, and the further movement of the upright will unlock the spring and allow it to seat the pin in the notches 17 in the ears 2. This holds the upright in its folded position, but permits it to be lifted up when desired, the pin riding up the curve 18 until it snaps over the upper lip 16 upon the upper incline of the cam.

In the modification shown in Figs. 7, 8, and 9 the base-plate 19 has two ears 20, which have radial slots 21 running up into them from below. The knuckle 22 of the upright 23 has a V-shaped cam 24 on its periphery with lips 25 at its ends. The pin 26 rides up and down in the slots 21, being urged up against the cam by a flat spring 27, secured to the base-plate and having a projecting finger-hold 28. When the upright is to be folded down out of the way, the spring is depressed by means of the finger-hold, so as to permit the lips 25 to pass

by the pin. The knuckle is preferably provided with one or more notches 29, so located that when the upright has been folded down the pin will engage therewith and hold the parts in position.

Having thus described my invention, what I claim is—

1. A rear sight for firearms, comprising a base, an upright pivoted thereto, a transverse pin parallel with the axis of the pivot, a spring urging said pin toward said pivot, and a V-shaped cam with which said pin coöperates to hold the upright yieldingly in a normal position.

2. A rear sight for firearms, comprising a base, an upright pivoted thereto, a transverse pin parallel with the axis of the pivot, a spring urging said pin toward said pivot, and a V-shaped cam with which said pin coöperates to hold the upright yieldingly in a normal position, said cam having lips at its ends to limit the play of the parts.

3. A rear sight for firearms, comprising a base, an upright pivoted thereto, a transverse pin parallel with the axis of the pivot, a spring urging said pin toward said pivot, and a V-shaped cam with which said pin coöperates to hold the upright yieldingly in a normal position, said cam having lips at its ends to limit the play of the parts, and means for withdrawing said pin beyond said lips to permit a free movement of the upright.

4. A rear sight for firearms, comprising a base-plate provided with ears having V-shaped cams, an upright having a knuckle pivoted between said ears and provided with a radial slot, a pin lying in said slot and engaging with said cams, and a spring urging said pin inwardly in said slot.

5. A rear sight for firearms, comprising a base-plate having ears provided with V-shaped cams, an upright having a knuckle pivoted between said ears and provided with a radial slot, a pin lying in said slot and engaging with

said cams, and a flat spring partly encircling said knuckle and having a head bearing on said pin.

6. A rear sight for firearms, comprising a base-plate having ears provided with V-shaped cams, an upright having a knuckle pivoted between said ears and provided with a radial slot, a pin lying in said slot and engaging with said cams, a spring urging said pin inwardly, and a dog pivoted concentric with the knuckle and adapted to pass under said pin.

7. The combination with a base-plate having ears provided with V-shaped cams having lips at their ends, of a bifurcated knuckle pivoted between said ears and having a radial slot, a pin in said slot, a spring bearing on said pin, and a dog pivoted in the fork of the knuckle and having a nose adapted to pass under said pin, and a tail projecting beyond the knuckle.

8. A rear sight for firearms, comprising a base-plate, an upright pivoted thereto and having a radial slot, a pin lying in said slot, a V-shaped cam on the base-plate with which said pin coöperates, a spring urging said pin toward said cam, and means which may be adjusted in position to hold the pin out of contact with said cam.

9. The combination with the base-plate 1 having the ears 2 provided with the V-shaped cams 8, the lips 16, the notch 17 and the curve 18, of the upright 4 having the knuckle 5 provided with the radial slot 6, the transverse pin 7, the flat spring 9 partly encircling the knuckle and bearing on the pin, and the dog 12 having the nose 14 adapted to pass under the pin and the tail 15 projecting beyond the periphery of the knuckle.

In testimony whereof I have signed my name to this specification in the presence of two subscribing witnesses.

GEORGE H. GARRISON.

Witnesses:

ELMER BEACH,
W. L. MARBLE.