

(19) World Intellectual Property Organization
International Bureau



(43) International Publication Date
1 March 2012 (01.03.2012)

(10) International Publication Number
WO 2012/027335 A1

(51) International Patent Classification:
B60C 23/10 (2006.01)

(21) International Application Number:
PCT/US2011/048760

(22) International Filing Date:
23 August 2011 (23.08.2011)

(25) Filing Language: English

(26) Publication Language: English

(30) Priority Data:
61/376,144 23 August 2010 (23.08.2010) US

(71) Applicant (for all designated States except US):
EQUALAIRE SYSTEMS, INC. [US/US]; 1414 Valero
Way, Corpus Christi, TX 78409 (US).

(72) Inventors; and
(75) Inventors/Applicants (for US only): HENNIG, Mark,
Kevin [US/US]; 13942 Cabana North, Corpus Christi,
TX 78418 (US). FOUNTAIN, Peter [US/US]; 3097 Car-
rie Lane, Leetonia, OH 44431 (US).

(74) Agents: PIZARRO, Derrick, A. et al.; Cox Smith
Matthews Incorporated, 112 E. Pecan Street, Suite 1800,
San Antonio, TX 78205 (US).

(81) Designated States (unless otherwise indicated, for every
kind of national protection available): AE, AG, AL, AM,
AO, AT, AU, AZ, BA, BB, BG, BH, BR, BW, BY, BZ,
CA, CH, CL, CN, CO, CR, CU, CZ, DE, DK, DM, DO,
DZ, EC, EE, EG, ES, FI, GB, GD, GE, GH, GM, GT,
HN, HR, HU, ID, IL, IN, IS, JP, KE, KG, KM, KN, KP,
KR, KZ, LA, LC, LK, LR, LS, LT, LU, LY, MA, MD,

[Continued on next page]

(54) Title: VALVE STEM WITH AUXILIARY PORT

(57) Abstract: A valve stem may comprise an auxiliary port. Devices such as an air pressure gauge, a tire pressure monitoring system sensor, temperature gauges and one-way valves may be mounted to the auxiliary port. A valve stem with auxiliary port may be used in an automatic tire inflation system. A sleeve may be translatably mounted to the valve stem to cover and uncover the auxiliary port.

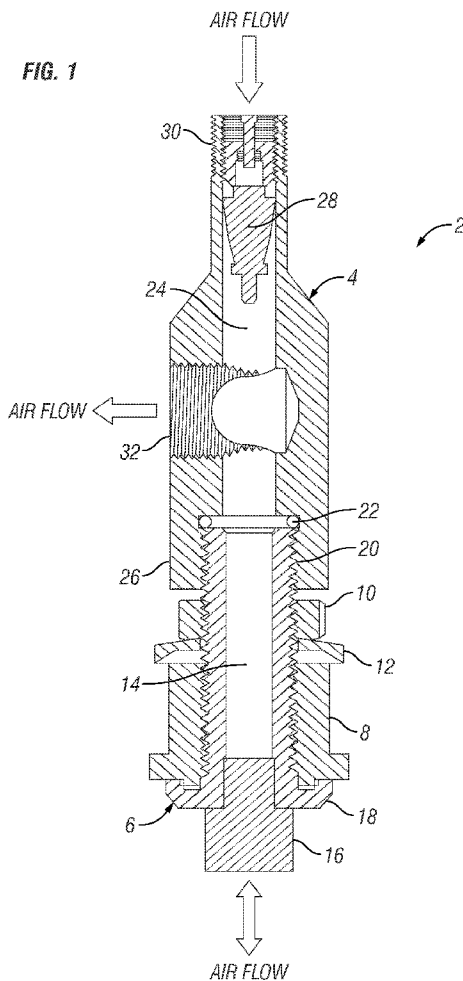

WO 2012/027335 A1



ME, MG, MK, MN, MW, MX, MY, MZ, NA, NG, NI, NO, NZ, OM, PE, PG, PH, PL, PT, QA, RO, RS, RU, SC, SD, SE, SG, SK, SL, SM, ST, SV, SY, TH, TJ, TM, TN, TR, TT, TZ, UA, UG, US, UZ, VC, VN, ZA, ZM, ZW.

LV, MC, MK, MT, NL, NO, PL, PT, RO, RS, SE, SI, SK, SM, TR), OAPI (BF, BJ, CF, CG, CI, CM, GA, GN, GQ, GW, ML, MR, NE, SN, TD, TG).

Published:

(84) Designated States (unless otherwise indicated, for every kind of regional protection available): ARIPO (BW, GH, GM, KE, LR, LS, MW, MZ, NA, SD, SL, SZ, TZ, UG, ZM, ZW), Eurasian (AM, AZ, BY, KG, KZ, MD, RU, TJ, TM), European (AL, AT, BE, BG, CH, CY, CZ, DE, DK, EE, ES, FI, FR, GB, GR, HR, HU, IE, IS, IT, LT, LU,

- with international search report (Art. 21(3))
- before the expiration of the time limit for amending the claims and to be republished in the event of receipt of amendments (Rule 48.2(h))

PCT INTERNATIONAL PATENT APPLICATION

TITLE:

VALVE STEM WITH AUXILIARY PORT

Inventors:

Mark Kevin Hennig
Citizenship: US

Peter Fountain
Citizenship: US

VALVE STEM WITH AUXILIARY PORT

CROSS-REFERENCE TO RELATED APPLICATION

[0001] This application claims priority to U.S. Provisional Patent Application 61/376,144 entitled “Valve Stem with Auxiliary Port” filed August 23, 2010, which is hereby entirely incorporated herein by reference.

FIELD

[0002] The disclosed method and apparatus generally relate to tire pressure maintenance.

BACKGROUND

[0003] Automatic tire inflation systems may rely on standard vehicle tire valve stems. Standard vehicle tire valve stems may not provide an auxiliary port for allowing an alternate path for air flow or for mounting auxiliary devices. There exists a need for a valve stem having an auxiliary port that is suitable for use with an automatic tire inflation system.

SUMMARY

[0004] A wheel end assembly comprising a hubcap mounted to a wheel rotatable on an axle, the wheel-end assembly comprising: a rotary union in or mounted to the hubcap, the rotary union in sealed fluid communication with an air pressure supply, an air hose having a first end and a second end, the first end connected to the rotary union so as to allow air to flow from the air pressure supply through the air hose, and a valve stem mounted to the wheel so as to allow inflation of a pneumatic tire, the valve stem comprising a first one-way valve and an auxiliary port, wherein the second end of the air hose is connected to the valve stem so as to allow fluid communication of pressurized air therewith. The wheel end assembly may further comprise one of an air pressure gauge, tire pressure monitoring system

sensor, temperature sensor and a second one-way valve, mounted to the auxiliary port. The second one-way valve may further comprise a pressure relief valve oriented so as to be capable of releasing air from the pneumatic tire, or oriented so as to be capable of allowing air to be added to the pneumatic tire.

[0005] An automatic tire inflation system for a pneumatic tire mounted to a wheel, the wheel having a hubcap mounted thereto, the system comprising: an air pressure supply, a rotary union in or mounted to the hubcap, the rotary union in sealed fluid communication with the air pressure supply, an air hose having a first end and a second end, the first end connected to the rotary union so as to allow air to flow from the air pressure supply through the air hose, and a valve stem mounted to the wheel so as to allow inflation of a pneumatic tire, the valve stem comprising a one-way valve and an auxiliary port, wherein the second end of the air hose is connected to the valve stem so as to allow fluid communication of pressurized air therewith.

[0006] An improved valve stem having disposed therein along its long axis a fluid channel, the improved valve stem comprising a base end configured for mounting to a wheel; a post end having a Schrader valve mounted in the fluid channel; one or more auxiliary ports disposed between the base end and the post end, the one or more auxiliary ports being in fluid communication with the fluid channel; a sleeve translatably disposed about the stem so as to allow closing and opening of the auxiliary ports; and a first seal disposed adjacent the one or more auxiliary ports for sealing engagement between the stem and sleeve.

BRIEF DESCRIPTION OF THE DRAWINGS

[0007] Fig. 1 illustrates one embodiment of a valve stem having an auxiliary port.

[0008] Fig. 2 illustrates one embodiment of a vehicle having an automatic tire inflation system.

[0009] Fig. 3 illustrates the automatic tire inflation system of Fig. 1 in more detail.

[0010] Figs. 4A and 4B illustrate another embodiment of a valve stem having an auxiliary port and a sleeve in a closed position covering the auxiliary port.

[0011] Figs. 5A and 5B illustrate the embodiment of Figs. 4A and 4B with the sleeve in an open position uncovering the auxiliary port.

DETAILED DESCRIPTION

[0012] As may be seen in the embodiment of FIG. 1, an improved tire valve stem 2 may comprise a post 4 and a base 6. The base 6 may be fitted within a seal 8 configured to allow snap-in mounting of the base 6 in a hole in a tire rim (not shown) in much the same manner as a standard tire valve stem. A nut 10 and a washer 12 may be removably mounted to the base 6, such as by threading, so as to retain the base 6 within the seal 8. The seal may be rubber, polyurethane, nylon or any suitable sealing material. In some embodiments, the base 6 may be retained within the seal by any suitable means, such as by friction fit, flanges, locking tabs, adhesives, and the like. Alternatively, the base 6 may be welded or threaded directly into a hole in a tire rim (not shown). The base 6 may include an air channel 14, located generally along the long axis of the base 6, that allows air to flow through the base 6. An air filter 16 may be mounted to a first end 18 of the base 6 to prevent contaminants from the pneumatic tire from entering the valve stem 2.

[0013] The post 4 may be removably mounted to a second end 20 of the base 6, such as by threaded attachment. Of course, the post 4 may be removably mounted to the base 6 by any suitable means, such as by friction fit, adhesives, detent pins, and the like, or be permanently mounted. In other embodiments, the post 4 and base 6 may be a unitary item of manufacture. In such embodiments, the words “post” and “base” may simply refer to portions of the item. A seal 22 may be provided to seal the connection between the post 4 and the base 6. The seal may be, for example, an o-ring, compression washer or adhesive, and may be of any suitable material, e.g., rubber, polyurethane, nylon or any suitable sealing

material. The post 4 may include an air channel 24, located generally along the long axis of the post 4, that allows air to flow through the post 4. Mounting of a first end 26 of the post 4 to the base 6 may allow air to flow between the air channel 24 of the post 4 and the air channel 14 of the base 6. A valve core 28, such as a Schrader valve, may be removably mounted, such as by threading, within a second end 30 the post 4. The valve core 28 may comprise a one-way valve that permits air to flow into the air channel 24 in one direction, but not the other. In the disclosed embodiment, the valve core may allow air to flow into the air channel 24 through the second end 30 of the post 4, but not in the other direction.

[0014] The post 4 may be provided with one or more auxiliary ports 32 that extend from the air channel 24 in a generally radial direction to the outer surface of the step portion 4. The auxiliary port 32 may allow a variety of components to be mounted to the valve stem 2. The auxiliary port 32 may be threaded, such as 1/8 NPT, to allow such components to be removably mounted. In one embodiment, a one-way pressure relief valve may be removably mounted to the auxiliary port to allow tire pressure in excess of the desired pressure to escape to the atmosphere. For example, air may be added to a cold tire so as to achieve a manufacturer-recommended tire pressure. As the tire heats up during use, the tire pressure may increase beyond a manufacturer-recommended tire pressure. Similarly, as a tire is driven from a lower elevation to a higher elevation, the tire pressure may increase. It may thus be desirable to release the excess tire pressure.

[0015] For example, an automatic pressure relief valve (not shown) may be mounted to the auxiliary port and configured to remain closed until the tire pressure exceeds approximately the manufacturer-recommended tire pressure or some other desired pressure. When the tire pressure exceeds the recommended tire pressure, the pressure relief valve may open to allow air to escape, thus lowering the tire pressure. When the tire pressure reaches approximately the recommended pressure, the pressure relief valve may close to prevent

further air loss. The pressure relief valve may thus be configured to automatically open when the tire pressure increases above a pressure threshold, and automatically close when the tire pressure drops below a pressure threshold.

[0016] In other embodiments, a tire pressure monitoring sensor and/or tire temperature monitoring sensor may be removably mounted to the auxiliary port. For example, a tire pressure and/or temperature monitoring sensor may include a SmarTire® / SmartWave® tire pressure monitoring system (TPMS) wireless tire sensor made by Bendix Commercial Vehicle Systems. An auxiliary port may provide a convenient way to mount such a sensor to the wheel without having to alter the tire rim.

[0017] In yet other embodiments, a tire valve stem having an auxiliary port may be used in connection with a tire inflation system, such as those disclosed in, for example, U.S. Patent Nos. 6,698,482, 6,105,645 or U.S. Pub. App. No. 2009/0283190. As may be seen in FIG. 2, a vehicle 100 may comprise a truck 102 and a trailer 104. The truck 102 may include one or more drive axles 106 as part of the vehicle's powertrain. The truck 102 may further include a steer axle (not shown in detail) having pivotable spindles that may provide steering capability for the vehicle 100. The trailer 104 may include one or more fixed axles (not shown). Each axle may have one or more wheels 108 mounted thereto. A pneumatic tire 110 may be mounted to each wheel 108.

[0018] The vehicle 100 may be provided with an automatic tire inflation system (such as is shown in Fig. 2) that uses pressurized air from the vehicle's air brake system or some other source of pressurized air to maintain the tires at a desired air pressure. The automatic tire inflation system may be used to control air pressure in one or more of the tires 110 mounted to the steer (not shown), drive 106 and trailer axles (not shown). The automatic tire inflation system may include one or more air hoses 112 in fluid communication with each tire 110 for communicating air from the air pressure source to and from one or more of the tires

110.

[0019] Fig. 2 illustrates in more detail multiple embodiments of an automatic tire inflation system for trailer tires. A trailer 200 may include two axles 202 and 204. Some trailers may have dual tires 206 and 208 mounted at each end of the axles, as may be seen with respect to axle 202. Other trailers may have one wide-base tire 210 mounted at each end of the axles, as may be seen with respect to axle 204. The automatic tire inflation system may generally include a pressure regulator 214 and one or more rotary air connections or rotary unions 216 and 218 mounted in or near the axle ends as described in more detail below. The pressure regulator 214 may receive pressurized air from an air pressure source 220 through a conduit 212. The air pressure source 220 may comprise, for example, a vehicle air brake system air supply, or a step-up or booster pump. The pressure regulator 214 may control or reduce the air pressure from the air pressure source 220 to an air pressure level suitable for inflating the tires 206, 208, 210, such as 110 psi. Pressurized air may flow from the pressure regulator 214 through conduit 222 to the axles 202 and 204.

[0020] The axles 202 and 204 may be wholly or partially solid or hollow, and may be configured in a variety of ways. For illustration purposes only, axles 202 and 204 are hollow. For example, in some embodiments, an axle may comprise a solid beam having a spindle attached to each end (not shown). The axle spindles may be configured to allow mounting of wheel bearings upon which a hub may be rotatably mounted (not shown). In other embodiments, an axle may comprise a hollow tube having a spindle attached to each end. The spindles may be hollow, resulting in a hollow axle that is open at each end. Alternatively, the spindles may be wholly or partially solid, resulting in a hollow axle that is closed at each end.

[0021] If the axle is open at the end, the axle may be sealed so as to allow the hollow axle to hold pressurized air and to support air conduits or rotary air connections (or

components thereof), for example, with a plug or cap disclosed in one of U.S. Patent Nos. 5,584,949, 5,769,979, 6,131,631, 6,394,556, 6,892,778, and 6,938,658. The open end may also be provided with a plug or cap that may serve more to support air conduits or rotary air connections (or components thereof) than to seal the hollow axle to hold pressurized air, such as a plug or cap disclosed in one of U.S. Patent Nos. 6,325,124 and 7,273,082.

[0022] In the embodiments of Fig. 2, axles 202 and 204 may be hollow sealed axles. In one embodiment, axle 204 may be hollow and may be sealed to serve as a conduit for pressurized air. The air conduit 222 may be sealingly connected to the axle 204 to allow pressurized air to flow from the pressure regulator 214 to the axle 204. The pressurized air may flow through the axle 204 to a rotary air connection 216 mounted in or near the spindle end as described in more detail below. An air hose 224 may be connected to the rotary air connection 216 to the valve stem (not shown) of the wheel 209 to which the tire 210 is mounted, thus allowing pressurized air to flow to and from the tire 210.

[0023] In some embodiments, the air conduit 222 may be sealingly connected to a tee 226 to allow pressurized air to flow both to axle 204 and to axle 202. An air conduit 228 may allow pressurized air to flow from the tee 226 to a conduit 230 disposed in axle 202. Axle 202 may carry an air conduit 230 to communicate pressurized air to rotary air connection 218, such as is disclosed in U.S. Patent Nos. 6,325,124 and 7,273,082. Air hoses 232 may connect the rotary air connection 218 to the valve stems 219 and 221 of the wheels 211 to which tires 206 and 208 are mounted, thus allowing pressurized air to flow to and from the tires 206 and 208. In other embodiments, if the axle 202 is solid, then a channel may be bored in axle 202 to permit positioning of all or part of conduit 230 inside the axle 202.

[0024] With reference to FIGS. 1 and 3, the base 6 of an improved valve stem 2 with auxiliary port may be mounted to each of the rims of tires 206, 208 and 210 in lieu of standard tire valve stems 219 and 221. The air hoses 232 and 224 may be connected to the

second end 30 of the improved valve stems 2, such as by threaded attachment. In operation, pressurized air from the air supply may pass through the automatic tire inflation system air lines 222, 228 and 230 to the rotary unions 216 and 218, and from the rotary unions 216 and 218 to the valve stems 2. In each valve stem 2, pressurized air may open the valve core 28, thus allowing air to pass through the valve core 28 through the air channels 24 and 14, and through the filter 16 into the tire. If excess pressure builds in the tire, air may travel back through the filter 16, back through the air channel 14 into air channel 24, and escape out through an automatic pressure relief valve (not shown) mounted in auxiliary port 32. The valve core 28 may remain closed to prevent air from flowing from the tire back into the automatic tire inflation system. In applications for which automatic pressure relief is not desirable, a manual pressure-relief valve may be mounted to the auxiliary port 32, for use in connection with an automatic tire inflation system. In such systems, if the tires are believed to be overpressurized, a driver or maintenance person may manually deflate the tires, for example, prior to starting the vehicle, to a level below the desired tire pressure. When the automatic tire inflation system starts, pressurized air will automatically bring the tires back up to the desired tire pressure.

[0025] If another type of device, such as an air pressure gauge (not shown) is mounted in auxiliary port 32, air may communicate between the tire and the device through the air channels 14 and 24, thus allowing the device to register the tire pressure or other air property, such as temperature. In further embodiments, a one-way valve, such as a Schrader valve, may be mounted to the auxiliary port to allow another point of entry for pressurized air. Such an embodiment may allow air to be added to the tire without having to remove the automatic tire inflation system air hose from the second end 30 of the post 4.

[0026] Figs. 4A and B, and 5A and B illustrate views of another embodiment of an improved valve stem 2. The post 4 may include a sleeve 40 that may be translated along the

post 4 so as to cover and uncover one or more auxiliary ports 32. The sleeve may be of any suitably rigid or semi-rigid material, such as metal, plastic, rubber or ceramic. One or more seals 42 may be disposed on the stem so as to allow sealing engagement of the post 4 and sleeve 40. For example, the seals 42 may be mounted circumferentially about the inside of the sleeve 40 in suitably-dimensioned grooves 44. Alternatively, the more seals may be mounted circumferentially about post 4 in suitably-dimensioned grooves (not shown). The seals 42 may be positioned adjacent the auxiliary ports 32, and may provide a sealing interface with the sleeve 40. The seals 42 may be o-rings, lip seals or any suitable seal, and may be of any suitable material, such as nitrile or rubber. In a first position, as shown in Fig. 4, the sleeve 40 may cover the auxiliary ports 32, and the seals 42 may provide a sealing interface with the sleeve 40 above and below the auxiliary ports 32 so as to prevent fluid flow through the auxiliary ports 32. In a second position, as shown in Fig. 5, the sleeve 40 may be disengaged from at least one of the seals 42 above or below the auxiliary ports 32 so as to allow fluid flow through the auxiliary ports 32.

[0027] The sleeve 40 may slidably translate from the first position to the second position, and from the second position to the first position. In one embodiment, the first position may be a default or “closed” position, and the sleeve may be biased toward the first position by a spring 46. A first end 48 of the spring 46 may be seated against a shoulder 50 of the post. A second end 52 of the spring 46 may be seated against a shoulder 54 provided on an inner surface of the sleeve 40. In a default or “closed” position of the sleeve 40, the spring 46 may be slightly compressed so as urge the sleeve 40 along the post 4 into that position. A lock ring 56 or nut may be provided about the post 4 to prevent the sleeve 40 from translating along the post 4 away from the spring 46. Thus, in a default or “closed” position of the sleeve 40, the spring 46 may urge the sleeve 40 against the lock ring 56.

[0028] The sleeve 40 may be manually translated along the post 4 from a “closed”

position as shown in Fig. 4 to a second or “open” position as shown in Fig. 5 so as to allow fluid communication through the auxiliary ports 32, e.g., air may travel from the air channel 24 to the atmosphere, and vice versa. Translation of the sleeve 40 from the “closed” position to the “open” position may compress the spring 46 such that when the manual force against sleeve 40 is released, the sleeve 40 will translate along the post 4 back to the “closed” position.

[0029] In some embodiments, a protective skirt or bellows 58 may extend from the sleeve 40 to the first end 26 of the post 4. The bellows 58, shown in outline form in Figs. 4 and 5, may be of a flexible material, such as rubber, cloth or silicone. The bellows 58 may be sealed to the sleeve 40 and to the first end 26 of the post 4 to prevent contamination from collecting inside the sleeve 40 and around the spring 46.

[0030] In other embodiments, the sleeve 40 may be threadably mounted to the post 4, and may rotatably translate along the post 4 along such threads (not shown). For example, instead of using a spring 46, the post 4 may be threaded and the inside of the sleeve 40 may be threaded to allow threadable mounting of the sleeve 40 to the post 4. The threads may serve as a seal in some embodiments. If the sleeve 40 is threaded to the post 4, then the sleeve 40 may be rotated about the post 4 to effect translation of the sleeve 40 along the post 4 from the “closed” position to the “open” position, and vice versa.

[0031] In yet other embodiments, the sleeve 40 may be retained in a “closed” position or “open” position by detents bumps provided on the post, or any other suitable mechanism for preventing the sleeve 40 from translating along the post 4 without application of force, such as grooves in the sleeve 40 to engage one or more of the seals 42.

[0032] When installed on a wheel in lieu of standard tire valves 219 and 221 as described above, the improved valve stem 2 of Figs. 4 and 5 may allow a user to manually deflate a tire to, for example, relieve overpressurization, without having to disconnect the air

hoses 232 and 224 of an automatic tire inflation system. Likewise, the improved valve stem 2 may be used in addition to standard valve stems, e.g., as a standalone stem mounted to a wheel, and similarly used to allow manual deflation of a tire.

[0033] One or more auxiliary ports 32 may be used in the embodiment of Figs. 4 and 5. The auxiliary ports 32 may be threaded or non-threaded, and may be sufficiently large to allow relatively rapid deflation of a tire compared to deflation using a standard valve stem. For example, the auxiliary ports 32 may be provided in a quantity and size sufficient to allow deflation of a tire by about 10 psi within about 10 seconds. In other embodiments, the auxiliary ports may be provided in a quantity and size sufficient for use in connection with the system of U.S. Prov. Pat. App. Ser. No. 61/494,327, entitled “Automatic Tire Inflation System with Manual Pressure Relief Valve,” the disclosure of which is incorporated entirely by reference.

[0034] In yet further embodiments, one or more improved valve stem having an auxiliary port may be provided in addition to a standard valve stem. Other holes may be provided in the wheel to accommodate improved valve stems on a wheel in addition to a standard valve stem.

[0035] Although the present invention and its advantages have been described in detail, it should be understood that various changes, substitutions and alterations can be made herein without departing from the invention as defined by the appended claims. Moreover, the scope of the present application is not intended to be limited to the particular embodiments of the process, machine, manufacture, composition, or matter, means, methods and steps described in the specification. As one will readily appreciate from the disclosure, processes, machines, manufacture, compositions of matter, means, methods, or steps, presently existing or later to be developed that perform substantially the same function or achieve substantially the same result as the corresponding embodiments described herein may

be utilized. Accordingly, the appended claims are intended to include within their scope such processes, machines, manufacture, compositions of matter, means, methods or steps.

CLAIMS

What is claimed is:

1. A wheel end assembly comprising a hubcap mounted to a wheel rotatable on an axle, the wheel-end assembly comprising:
 - a rotary union in or mounted to the hubcap, the rotary union in sealed fluid communication with an air pressure supply;
 - an air hose having a first end and a second end, the first end connected to the rotary union so as to allow air to flow from the air pressure supply through the air hose; and
 - a valve stem mounted to the wheel so as to allow inflation of a pneumatic tire, the valve stem comprising a first one-way valve and an auxiliary port, wherein the second end of the air hose is connected to the valve stem so as to allow fluid communication of pressurized air therewith.
2. The wheel end assembly of claim 1 further comprising one of an air pressure gauge, tire pressure monitoring system sensor, temperature sensor and a second one-way valve, mounted to the auxiliary port.
3. The wheel end assembly of claim 2, wherein the second one-way valve comprises a pressure relief valve oriented so as to be capable of releasing air from the pneumatic tire.
4. The wheel end assembly of claim 3, wherein the second one-way valve is oriented so as to be capable of allowing air to be added to the pneumatic tire.
5. An automatic tire inflation system for a pneumatic tire mounted to a wheel, the wheel having a hubcap mounted thereto, the system comprising:
 - an air pressure supply;
 - a rotary union in or mounted to the hubcap, the rotary union in sealed fluid communication with the air pressure supply;
 - an air hose having a first end and a second end, the first end

connected to the rotary union so as to allow air to flow from the air pressure supply through the air hose; and
a valve stem mounted to the wheel so as to allow inflation of a pneumatic tire, the valve stem comprising a one-way valve and an auxiliary port, wherein the second end of the air hose is connected to the valve stem so as to allow fluid communication of pressurized air therewith.

6. An improved valve stem having disposed therein along its long axis a fluid channel, the improved valve stem comprising:

a base end configured for mounting to a wheel;
a post end having a Schrader valve mounted in the fluid channel;
one or more auxiliary ports disposed between the base end and the post end, the one or more auxiliary ports being in fluid communication with the fluid channel;
a sleeve translatably disposed about the stem so as to allow closing and opening of the auxiliary ports; and
a first seal disposed adjacent the one or more auxiliary ports for sealing engagement between the stem and sleeve.

7. The improved valve stem of claim 6 further comprising:

the first seal being disposed between the one or more auxiliary ports and the post end;
a lock ring disposed between the first seal and the post end;
a second seal disposed for sealing engagement between the stem and sleeve, the second seal being disposed about the stem adjacent the one or more auxiliary ports and between the one or more auxiliary ports and the base end;
a spring slidably disposed about the stem, a first end of the spring being between the second seal and the base end, and a second end of the spring abutting the sleeve so as to urge the sleeve against the lock ring;

wherein when the sleeve is urged against the lock ring, the one or more auxiliary ports are closed and the first and second seals sealingly engage the stem and sleeve; and

wherein the sleeve may be forcibly translated against spring pressure along the stem away from the first seal so as to open the auxiliary ports and allow fluid to flow therethrough.

7. The improved valve stem of claim 7 further comprising a bellows sealed at a first end to the sleeve and at a second end to the stem between the first end of the spring and the base end.

1/5

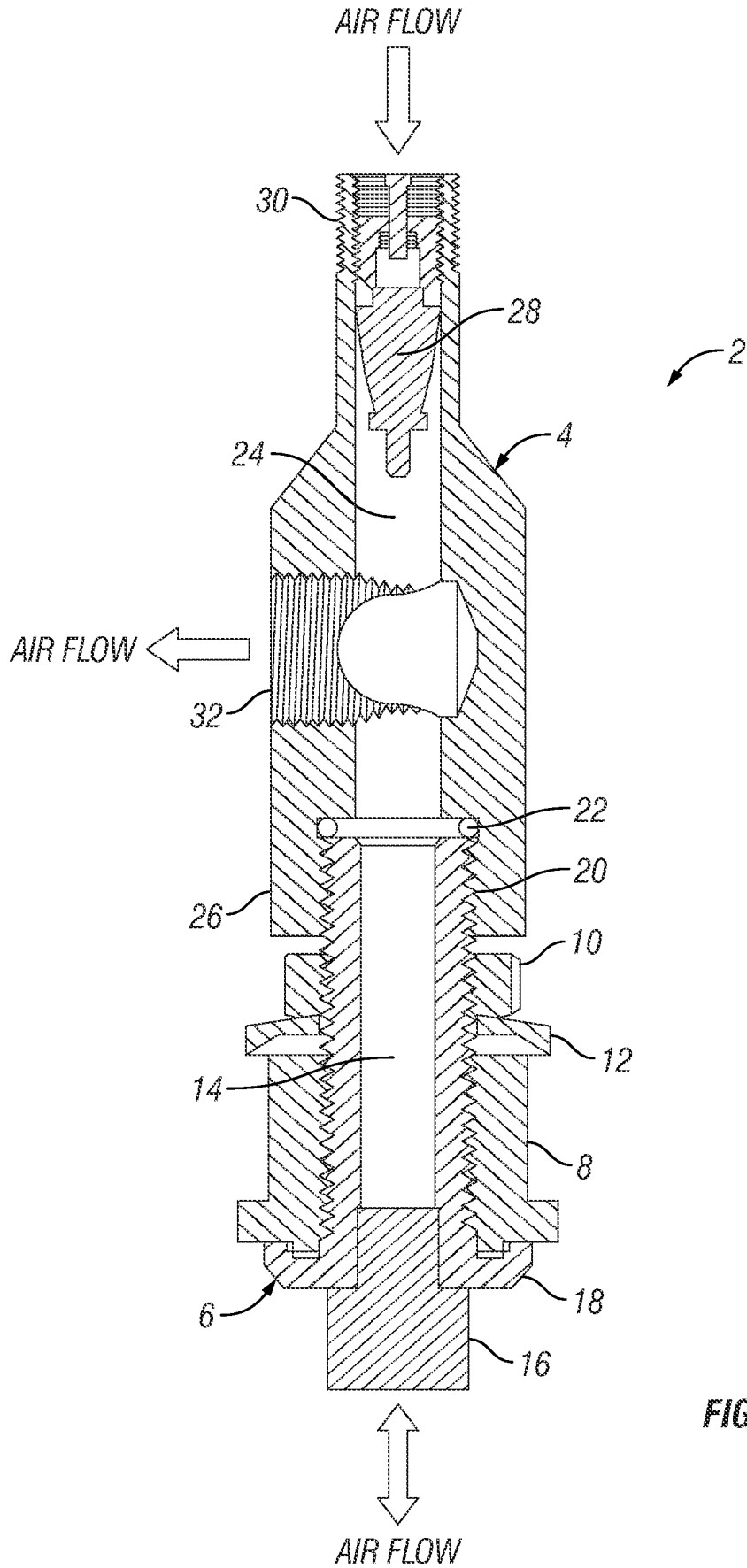

FIG. 1

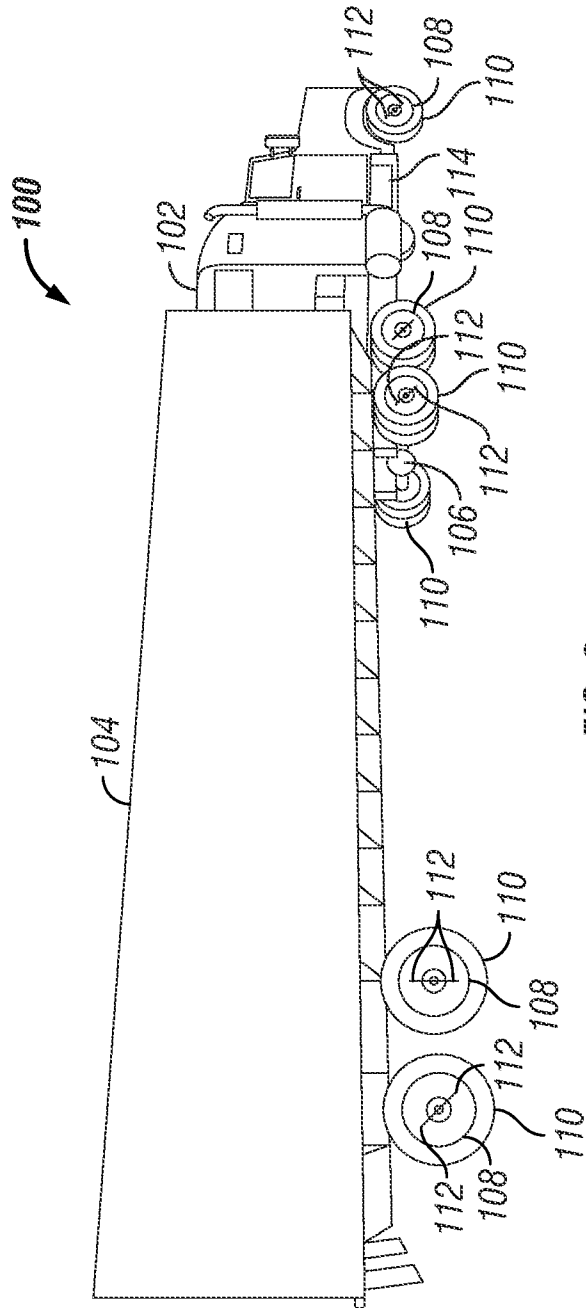

FIG. 2

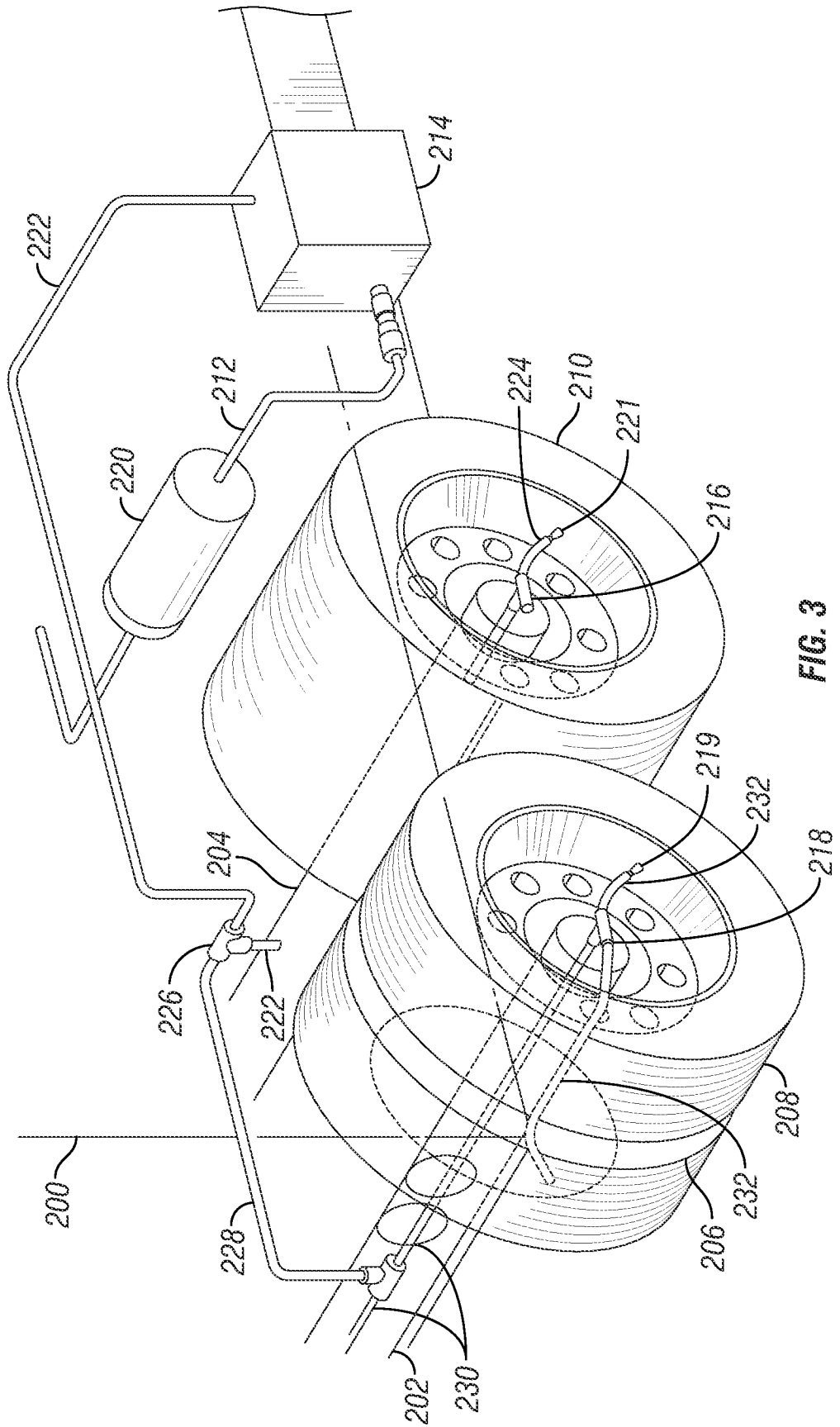

FIG. 3

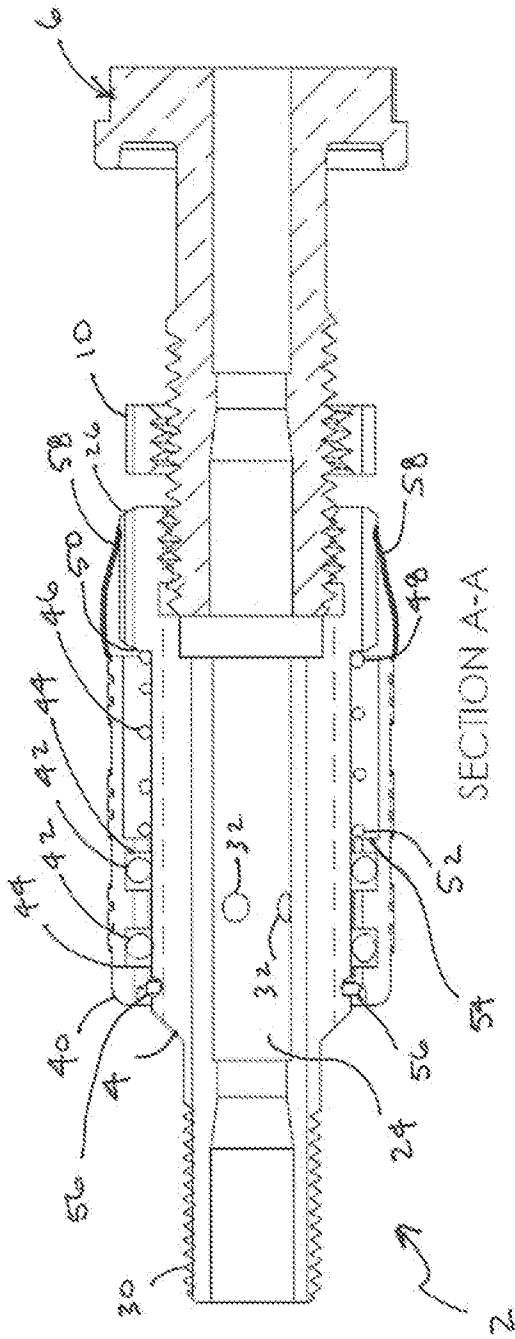

Fig. 4B

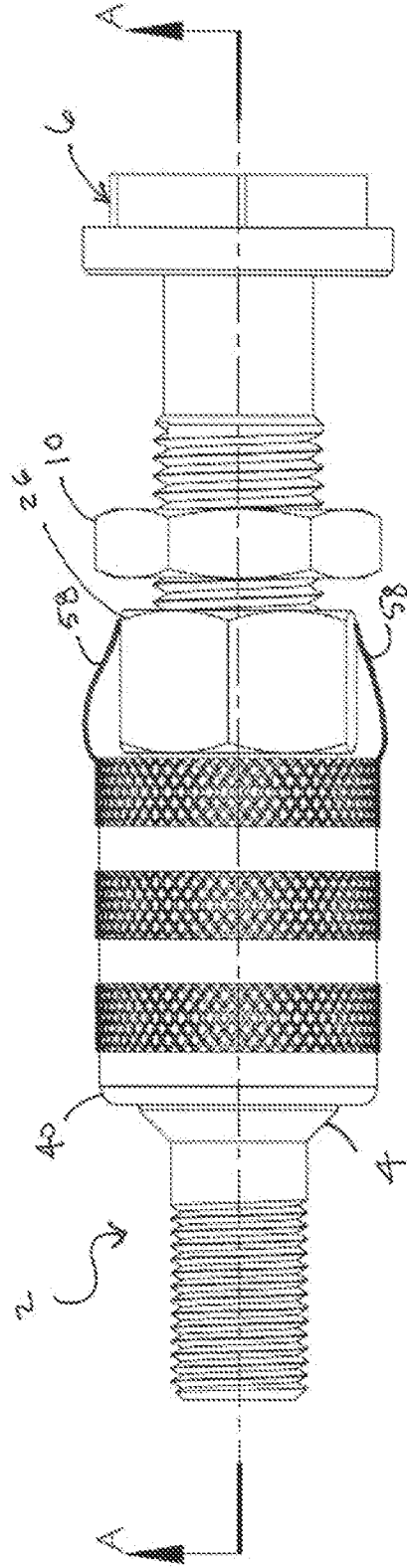

Fig. 4A

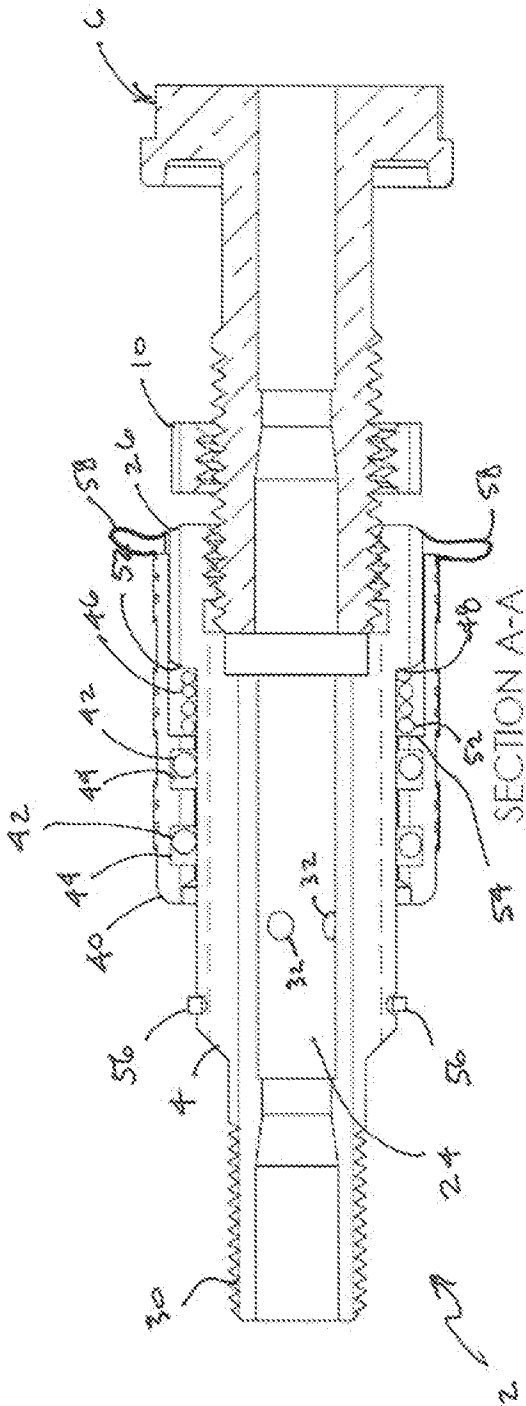

FIG. 5B

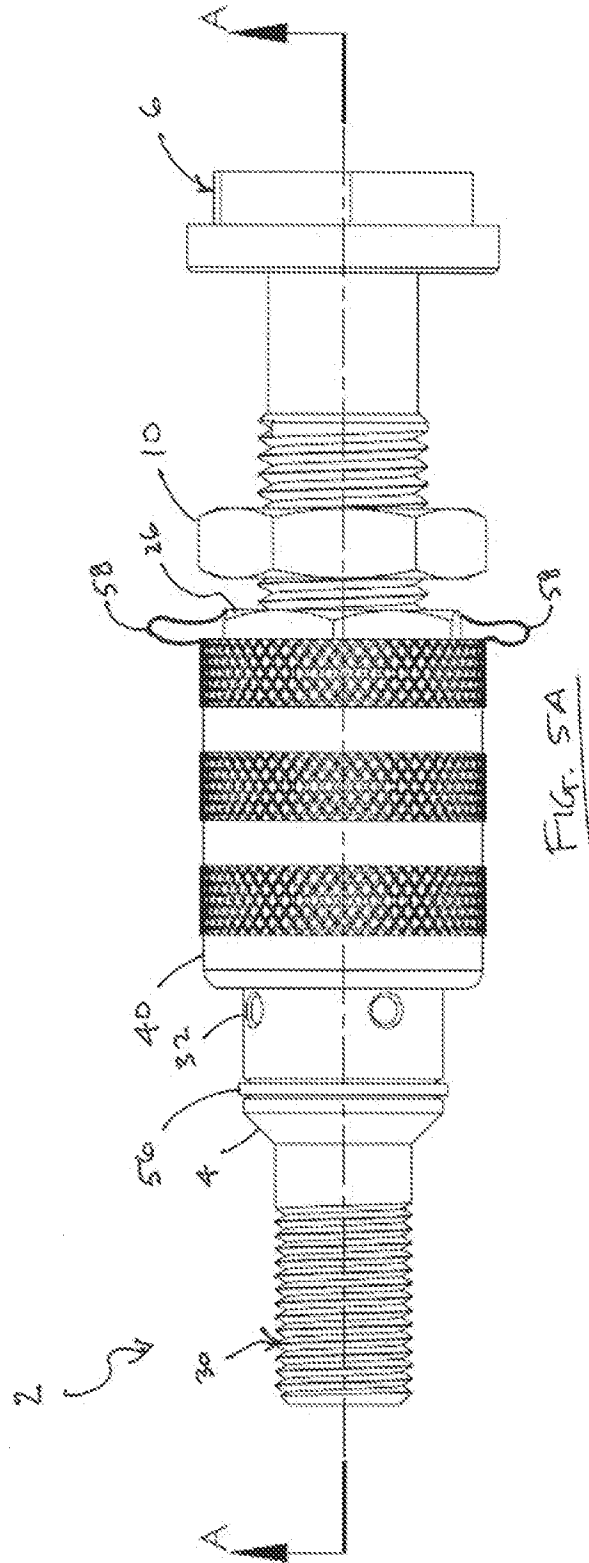

FIG. 5A

INTERNATIONAL SEARCH REPORT

International application No.

PCT/US 11/48760

A. CLASSIFICATION OF SUBJECT MATTER IPC(8) - B60C 23/10 USPC - 152/427 According to International Patent Classification (IPC) or to both national classification and IPC		
B. FIELDS SEARCHED		
Minimum documentation searched (classification system followed by classification symbols) USPC: 152/427		
Documentation searched other than minimum documentation to the extent that such documents are included in the fields searched IPC(8): B60C 29/00, 29/06 USPC: 73/146, 146.2, 146.3, 146.8; 116/34R, 34A, 34B; 301/108.1; 152/415, 418, 419, 427, 429, 430, 431----see search terms below----		
Electronic data base consulted during the international search (name of data base and, where practicable, search terms used) PUBWEST (US Pre-Grant Pub Full-Text, US Patents Full-Text, EPO Abstracts, JPO Abstracts); Google Patents (All); Google Web (All)-- -search terms: valve stem, tire, auxiliary, accessory, port valve, vent, rotary union, rotary, attachment, schrader, temperature, sleeve, spring, lock ring, bellows, check valve, adjacent, two, dual, second, multiple, on		
C. DOCUMENTS CONSIDERED TO BE RELEVANT		
Category*	Citation of document, with indication, where appropriate, of the relevant passages	Relevant to claim No.
Y	US 2008/0185086 A1 (INGRAM ET AL.) 7 August 2008 (07.08.2008) see entire document, particular Abstract; FIGS. 1 and 2; para [0030]-[0032], [0041] and [0045].	1-5
Y	US 6,167,900 B1 (LAIRD) 2 January 2001 (02.01.2001) see entire document, particular FIG. 2; col 2 ln 24-34; col 2, ln 66 to col 3, ln 11.	1-5
Y	US 5,694,969 A (DeVUYST) 9 December 1997 (09.12.1997) see entire document, particular Abstract; FIG. 1; col 3, ln 56-63.	3, 4 and 7b
Y	US 2,854,018 A (KILMARX, JR.) 30 September 1958 (30.09.1958) see entire document, particular FIG. 1; col 1, ln 48-57; col 2, ln 1 and 2; col 2, ln 3-6; col 2, ln 15-19; col 2, ln 43 to col 3, ln 22.	6, 7a, 7b
Y	US 7,404,412 B2 (MILANOVICH ET AL.) 29 July 2008 (29.07.2008) see entire document, particular col 2, ln 45-59.	6, 7a, 7b
A	US 2009/0241655 A1 (INGRAM ET AL.) 1 October 2009 (01.10.2009) see entire document.	1-6, 7a, 7b
A	US 6,772,812 B1 (HAMILTON) 10 August 2004 (10.08.2004) see entire document.	1-6, 7a, 7b
A	US 7,191,796 B1 (REHMERT, JR.) 20 March 2007 (20.03.2007) see entire document.	1-6, 7a, 7b
<input type="checkbox"/> Further documents are listed in the continuation of Box C. <input type="checkbox"/>		
* Special categories of cited documents:	"T" later document published after the international filing date or priority date and not in conflict with the application but cited to understand the principle or theory underlying the invention	
"A" document defining the general state of the art which is not considered to be of particular relevance	"X" document of particular relevance; the claimed invention cannot be considered novel or cannot be considered to involve an inventive step when the document is taken alone	
"E" earlier application or patent but published on or after the international filing date	"Y" document of particular relevance; the claimed invention cannot be considered to involve an inventive step when the document is combined with one or more other such documents, such combination being obvious to a person skilled in the art	
"L" document which may throw doubts on priority claim(s) or which is cited to establish the publication date of another citation or other special reason (as specified)	"&" document member of the same patent family	
"O" document referring to an oral disclosure, use, exhibition or other means		
"P" document published prior to the international filing date but later than the priority date claimed		
Date of the actual completion of the international search 20 January 2012 (20.01.2012)	Date of mailing of the international search report 02 FEB 2012	
Name and mailing address of the ISA/US Mail Stop PCT, Attn: ISA/US, Commissioner for Patents P.O. Box 1450, Alexandria, Virginia 22313-1450 Facsimile No. 571-273-3201	Authorized officer: Lee W. Young PCT Helpdesk: 571-272-4300 PCT OSP: 571-272-7774	