

CORRECTED VERSION

(19) World Intellectual Property Organization
International Bureau



(10) International Publication Number
WO 2016/069895 A9

(43) International Publication Date
6 May 2016 (06.05.2016)

- (51) International Patent Classification: C12M 1/12 (2006.01) C12M 3/00 (2006.01)
- (21) International Application Number: PCT/US2015/058053
- (22) International Filing Date: 29 October 2015 (29.10.2015)
- (25) Filing Language: English
- (26) Publication Language: English
- (30) Priority Data: 62/069,996 29 October 2014 (29.10.2014) US
- (71) Applicant: CORNING INCORPORATED [US/US]; 1 Riverfront Plaza, Corning, New York 14831 (US).
- (72) Inventors: MARTIN, Gregory Roger; 227 Peck Road, Acton, ME 04001 (US). TANNER, Allison Jean; 380 Greenleaf Avenue, Portsmouth, NH 03801 (US).
- (74) Agent: WILKS, Susan S; Corning Incorporated, Intellectual Property Department, SP-Ti-03, Corning, New York 14831 (US).
- (81) Designated States (unless otherwise indicated, for every kind of national protection available): AE, AG, AL, AM, AO, AT, AU, AZ, BA, BB, BG, BH, BN, BR, BW, BY, BZ, CA, CH, CL, CN, CO, CR, CU, CZ, DE, DK, DM, DO, DZ, EC, EE, EG, ES, FI, GB, GD, GE, GH, GM, GT, HN, HR, HU, ID, IL, IN, IR, IS, JP, KE, KG, KN, KP, KR, KZ, LA, LC, LK, LR, LS, LU, LY, MA, MD, ME, MG, MK, MN, MW, MX, MY, MZ, NA, NG, NI, NO, NZ, OM, PA, PE, PG, PH, PL, PT, QA, RO, RS, RU, RW, SA, SC, SD, SE, SG, SK, SL, SM, ST, SV, SY, TH, TJ, TM, TN, TR, TT, TZ, UA, UG, US, UZ, VC, VN, ZA, ZM, ZW.
- (84) Designated States (unless otherwise indicated, for every kind of regional protection available): ARIPO (BW, GH, GM, KE, LR, LS, MW, MZ, NA, RW, SD, SL, ST, SZ, TZ, UG, ZM, ZW), Eurasian (AM, AZ, BY, KG, KZ, RU, TJ, TM), European (AL, AT, BE, BG, CH, CY, CZ, DE,

[Continued on next page]

(54) Title: CELL CULTURE INSERT

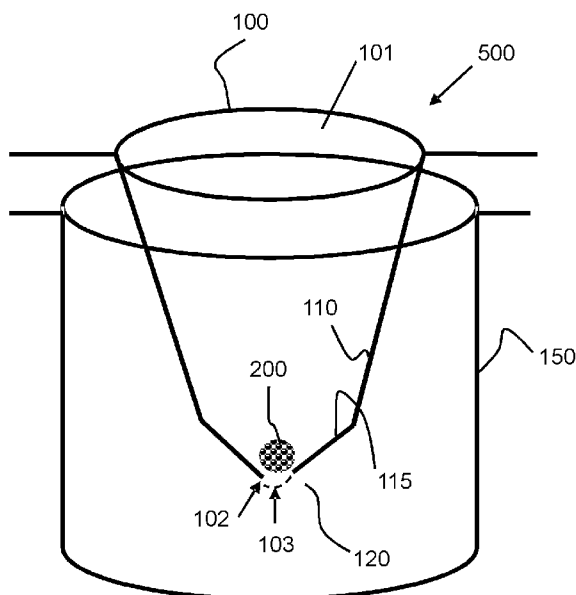

FIG. 1A

(57) Abstract: A cell culture insert for use in culturing cells to promote the formation of spheroids and methods of using these spheroid-promoting cell culture inserts. The cell culture insert includes a porous membrane and one or more sidewalls that are non-adherent to cells and cause the cells in the insert to associate with each other and form spheroids.



WO 2016/069895 A9

DK, EE, ES, FI, FR, GB, GR, HR, HU, IE, IS, IT, LT,
LU, LV, MC, MK, MT, NL, NO, PL, PT, RO, RS, SE,
SI, SK, SM, TR), OAPI (BF, BJ, CF, CG, CI, CM, GA,
GN, GQ, GW, KM, ML, MR, NE, SN, TD, TG).

(48) Date of publication of this corrected version:

20 April 2017

(15) Information about Correction:

see Notice of 20 April 2017

Published:

— *with international search report (Art. 21(3))*

CELL CULTURE INSERT

[0001] This application claims the benefit of priority under 35 U.S.C. § 119 of U.S. Provisional Application Serial No. 62/069996 filed on October 29th, 2014 the content of which is relied upon and incorporated herein by reference in its entirety.

FIELD

[0002] The present disclosure relates to apparatuses, systems and methods for culturing cells.

TECHINCAL BACKGROUND

[0003] The present disclosure relates generally to cell culture inserts for use in culturing cells to promote the formation of spheroids and methods of using these spheroid-promoting cell culture inserts. Spheroids are three-dimensional (3D) cell clusters that can provide more *in vivo*-like functions to the cells than cells cultured as monolayers in 2D cell culture systems. For certain cell types, such as hepatocytes, spheroids can attain and retain better *in vivo*-like functionality than their 2D cultured counterparts.

BRIEF SUMMARY

[0004] In accordance with various embodiments of the present disclosure, cell culture inserts for use in culturing cells to promote the formation of spheroids and methods of using these spheroid-promoting cell culture inserts are described. In some embodiments, a cell culture insert as described herein can be nested in another cell culture insert or another cell culture insert can be nested in a cell culture insert as described herein.

[0005] In various embodiments, the disclosure describes a cell culture insert having a body and a porous membrane. The body has a first open end, a second end wherein the second end defines an opening having a diametric dimension in a range from 100 μm to 1000 μm (e.g., 100, 200, 300, 400, 500, 600, 700, 800, 900, 1000 and all values and ranges therein between; e.g., 200 to 500, 200 to 700, 400 to 600, etc.), and one or more sidewalls extending from the first open end to the second end. The one or more sidewalls, or a portion thereof, are sloped (e.g., greater than 5 degrees from

perpendicular relative to first or second ends; e.g., $>10^\circ$, $>20^\circ$, $>30^\circ$, $>40^\circ$, $>50^\circ$, etc.). The sidewalls, if sloped, are preferably sloped such that the diameter at the second is less than the diameter at the first open end. A porous membrane is disposed over the opening of the second end.

[0006] In various embodiments, the disclosure describes a cell culture insert having a body and a porous membrane. The body has a first open end, a second end wherein the second end defines an opening, and one or more sidewalls extending from the first open end to the second end. The one or more sidewalls, or a portion thereof, are sloped. The porous membrane is disposed over the opening of the second end and is non-adherent to cells.

[0007] In various embodiments, the disclosure describes a permeable support device configured to be at least partially inserted into a reservoir of a cell culture device. The permeable support device comprises a first well having a tapered shape and bottom at least partially defined by a first permeable support.

[0008] In various embodiments, the disclosure described a cell culture insert. The insert includes a body having a first open end, a second end, and one or more sidewalls extending from the first open end to the second end. The second end comprises a substrate having an array of microwells defining wells with a porous membrane at the bottom, wherein at least a portion of a substrate having an array of microwells defining a well is sloped.

[0009] In various embodiments, the disclosure describes a nested permeable support device comprising a first well having a tapered shape and a bottom portion at least partially defined by a first permeable support, and a reservoir having a bottom located below the first well. In embodiments the reservoir is made from gas permeable material or has an array of microwells or both.

[0010] In various embodiments, the disclosure describes a nested permeable support device comprising a first well, a second well and a third well. The first well has a bottom, wherein at least a portion of the bottom is formed by a first porous membrane. The second well has a bottom, wherein at least a portion of the bottom is formed by a second porous membrane. A portion of either the first or the second permeable support may comprise an arcuate shape. The second well and the second permeable support are located below the first well and the first permeable support.

The third well has a non-liquid permeable, gas permeable bottom which is located below the second well and the second permeable support.

[0011] In another embodiment, the disclosure describes a nested permeable support device comprising a first well, a second well, and a third well. The first well has a substrate forming a microwell array, the bottom of which is a porous membrane. The second well has a substrate forming a microwell array, the bottom of which is a porous membrane. The third well has a substrate forming a microwell array, the bottom of which is a non-liquid permeable, gas permeable support. The second well with the microwell array substrate with the porous membrane bottom is located beneath the first well with the microwell array substrate with the first porous membrane bottom and above the third well with the microwell array substrate with the non-liquid permeable, gas permeable bottom.

[0012] Additional features and advantages of the subject matter of the present disclosure will be set forth in the detailed description which follows, and in part will be readily apparent to those skilled in the art from that description or recognized by practicing the subject matter of the present disclosure as described herein, including the detailed description which follows, the claims, as well as the appended drawings.

[0013] It is to be understood that both the foregoing general description and the following detailed description present embodiments of the subject matter of the present disclosure, and are intended to provide an overview or framework for understanding the nature and character of the subject matter of the present disclosure as it is claimed. The accompanying drawings are included to provide a further understanding of the subject matter of the present disclosure, and are incorporated into and constitute a part of this specification. The drawings illustrate various embodiments of the subject matter of the present disclosure and together with the description serve to explain the principles and operations of the subject matter of the present disclosure. Additionally, the drawings and descriptions are meant to be merely illustrative, and are not intended to limit the scope of the claims in any manner.

BRIEF DESCRIPTION OF THE FIGURES

[0014] The following detailed description of specific embodiments of the present disclosure can be best understood when read in conjunction with the following drawings, where like structure is indicated with like reference numerals and in which:

[0015] **FIGS. 1A-C** shows schematic diagrams of embodiments of cell culture inserts in which cells can be cultured to form a spheroid.

[0016] **FIG. 2A** and **2B** shows schematic diagrams of embodiments of a portion of a cell culture insert in which cells can be cultured to form a spheroid.

[0017] **FIGS. 3A-D** shows **A**, schematic diagram (side view) of embodiments of a cell culture insert in which cells can be cultured to form one or more spheroids; **B**, one embodiment of a substrate having an array of microwells at the second end of a cell culture insert; **C**, schematic diagram (top view) of the second end of a cell culture insert in which cells can be cultured to form one or more spheroids; **D**, schematic diagram (enlarged side view) of an array of microwells on a substrate with a bottom having a porous membrane forming the second end of a cell culture insert in which cells can be cultured to form one or more spheroids.

[0018] **FIGS. 4A-B** shows schematic diagrams of some embodiments of nested cell culture inserts in which cells can be cultured to form one or more spheroids.

[0019] **FIG. 5A-B** shows schematic diagrams of some embodiments of nested cell culture inserts in which cells can be cultured to form one or more spheroids on any or all of the cell culture substrates forming the well bottoms.

DETAILED DESCRIPTION

[0020] Reference will now be made in greater detail to various embodiments of the subject matter of the present disclosure, some embodiments of which are illustrated in the accompanying drawings. The same reference numerals will be used throughout the drawings to refer to the same or similar parts. However, it will be understood that the use of a number to refer to a component in a given figure is not intended to limit the component in another figure labeled with the same

number. In addition, the use of different numbers to refer to components is not intended to indicate that the different numbered components cannot be the same or similar to other numbered components.

[0021] The present disclosure describes, among other things, spheroid-promoting cell culture inserts and methods of using spheroid-promoting cell culture inserts. In some embodiments, the spheroid-promoting cell culture inserts will be contained in a cell culture apparatus. In some embodiments, the spheroid-promoting cell culture inserts can be placed in another cell culture insert or another spheroid-promoting cell culture insert. In some embodiments, the spheroid-promoting cell culture insert can contain another cell culture insert or another spheroid-promoting cell culture insert. In various embodiments, a method of using spheroid-promoting cell culture inserts includes performing an experiment to test a New Chemical Entity (NCE) or a New Biological Entity (NBE).

[0022] Cell culture devices or apparatuses that include nested permeable support devices can be adapted to have a spheroid-promoting cell culture insert. Examples of such cell culture devices or apparatuses include TRANSWELL® Permeable Supports (Corning, Inc.), and MILLICELL® Cell Culture Inserts (EMD Millipore), as well as the cell culture articles and methods described in U.S. Patent No. 8,163,537, which is incorporated herein by reference in its entirety to the extent that it does not conflict with the disclosure presented herein.

[0023] Referring now to **FIGS. 1A-C**, schematic side views of embodiments of cell culture apparatuses **500** are shown. The apparatuses **500** include spheroid-promoting cell culture inserts **100** that have one or more sidewalls **110** that are non-adherent to cells to cause the cells in the insert **100** to associate with each other and form spheroids **200**. In embodiments, the insert fits inside a reservoir or a well **150** of a multiwell cell culture plate. In some embodiments, the one or more sidewalls **110** can be coated with an ultra-low binding material to make the wall non-adherent to cells. Examples of non-adherent material include perfluorinated polymers, olefins, or like polymers or mixtures thereof. Other examples include agarose, non-ionic hydrogels such as polyacrylamides, or polyethers such as polyethyleneoxide or polyols such as polyvinylalcohol or like materials or mixtures thereof.

[0024] The one or more sidewalls **110** of the spheroid-promoting cell culture inserts **100** include a portion that is sloped **115**. In some embodiments, the one or more sidewalls can be sloped along their entire length. In other embodiments, only a portion of one or more sidewalls is sloped.

[0025] The one or more sidewalls **110** and other components of the spheroid-promoting cell culture inserts **100** can be formed of any suitable material. Preferably, materials intended to contact cells or culture media are compatible with the cells and the media. Typically, cell culture components are formed from polymeric material. Examples of suitable polymeric materials include polystyrene, polymethylmethacrylate, polyvinyl chloride, polycarbonate, polysulfone, polystyrene copolymers, fluoropolymers, polyesters, polyamides, polystyrene butadiene copolymers, fully hydrogenated styrenic polymers, polycarbonate PDMS copolymers, and polyolefins such as polyethylene, polypropylene, polymethyl pentene, polypropylene copolymers and cyclic olefin copolymers, and the like.

[0026] The spheroid-promoting cell culture insert **100** includes a body having a first open end **101** and a second end **102** wherein the end **102** defines an opening. A porous membrane **120** can cover the opening of the second end. In some embodiments, the porous membrane **120** can be adherent to cells. In other embodiments, the porous membrane **120**, or a portion thereof, can be non-adherent to cells **200**.

[0027] Referring now to **FIG. 2A** and **FIG. 2B**, the opening of the second end **102** of the body of the spheroid-promoting cell culture insert **100** can have a variety of shapes. In some embodiments, the opening forms a circle or an oval. In other embodiments, the opening defines a rectangle or other quadrilateral. In some embodiments, the opening of the second end has diametric dimension, such as a diameter, a width, a diagonal of a square or rectangle, or the like, d_1 in a range from 100 μm to 1000 μm . Specifically, the opening of the second end can have a diametric dimension d_1 of 100 μm , 150 μm , 200 μm , 250 μm , 300 μm , 350 μm , 400 μm , 450 μm , 500 μm , 550 μm , 600 μm , 650 μm , 700 μm , 750 μm , 800 μm , 850 μm , 900 μm , 950 μm , or 1000 μm , and any dimension encompassed within the range from 100 μm to 1000 μm .

[0028] The porous membrane **120** can have a variety of shapes. In some embodiments, the porous membrane **120** completely covers the opening of the second end of the body of the spheroid-promoting cell culture insert **100**. In some embodiments the porous membrane can have an arcuate

or curved shape. In some embodiments the second end of the body of the spheroid promoting cell culture insert is comprised of a microwell array with a porous membrane forming the bottom.

[0029] The porous membrane can be made of a variety of different materials including but not limited to track-etched membrane or a woven or non-woven porous material. The material of the porous membrane may be treated or coated to make it more adherent or more non-adherent to cells. Treatment may be accomplished by any number of methods known in the art which include plasma discharge, corona discharge, gas plasma discharge, ion bombardment, ionizing radiation, and high intensity UV light. Coatings can be introduced by any suitable method known in the art including printing, spraying, condensation, radiant energy, ionization techniques or dipping. The coatings may then provide either covalent or non-covalent attachment sites. Such sites can be used to attach moieties, such as cell culture components (e.g., proteins that facilitate growth or adhesion). Further, the coatings may also be used to enhance the attachment of cells (e.g., polylysine). Alternatively, cell non-adherent coatings as described above can be used to prevent or inhibit cell binding.

[0030] In embodiments, the porous membrane may be a substrate having an array of microwells.

[0031] In some embodiments, the spheroid formed by the cells **200** occludes the porous membrane **120** of the spheroid-promoting cell culture insert. (See for example, Fig. 1A). In some aspects, this occlusion prevents the passage of proteins, small molecules, and/or media from going around the spheroid.

[0032] The combination of, for example, non-adherent sidewalls, geometry, and gravity can define a confinement volume in which growth of cells cultured in the inserts is limited. In embodiments, this combination can promote the formation of spheroids by cells cultured in the inserts. The confinement volume can be defined by the portion of the one or more sidewalls proximate the second end and the width or diagonal of the second opening. In some embodiments, the portion of the one or more sidewalls proximate the second end d_2 is 500 μm , 450 μm , 400 μm , 350 μm , 300 μm , 250 μm , 200 μm , 150 μm , or 100 μm , or any length in between. In some embodiments the confinement volumes are defined by the wells of the microwell array substrate with the porous membrane that forms the bottom of the second opening. In which case, the second opening approximates the size of the first opening with the wells of the microwell array substrate comprising

the confinement volume and have a diameter of d_1 500 μm , 450 μm , 400 μm , 350 μm , 300 μm , 250 μm , 200 μm , 150 μm , or 100 μm , or any length in between.

[0033] Referring back to **FIG. 1C**, in some embodiments, the spheroid-promoting cell culture insert can further include a ledge **130** extending around the perimeter of the first open end where the ledge **130** is sized to support the spheroid-promoting cell culture insert **100** when it is positioned inside a reservoir **150**. In some embodiments, at least a portion of the reservoir **150** is gas permeable.

[0034] As shown in **FIG. 1A**, a spheroid **200** can grow in a spheroid-promoting cell culture insert **100**, a portion of which can include a porous membrane **120**. One or both of the porous membrane **120** and the lower sidewalls **110** can be non-adherent to cells. The slope of the sidewall **110** encourages the seeded cells **200** to aggregate on the porous membrane **120**. One or more of gravity, an ultra-low binding material, the sidewall geometry of the cell culture insert, and the arcuate shape of the porous membrane can facilitate the formation of a spheroid. In addition, in embodiments, the porous membrane may contain an array of microwells structured and arranged to form spheroids.

[0035] As shown in **FIG. 1B**, a spheroid can grow in a spheroid-promoting cell culture insert **100**, a portion of which is a porous membrane **120**. The porous membrane **120** and the lower sidewalls **110** can be non-adherent to cells. The slope of the sidewall **110** encourages the seeded cells to aggregate on or occlude the porous membrane **120**. One or more of gravity, an ultra-low binding material, the sidewall geometry of the cell culture insert, and the cell confinement volume around the porous membrane **120** can facilitate the formation of a spheroid. The size of the spheroid can be limited by the confinement volume. In embodiments, the second end of the insert can have a shape that provides a confinement volume that promotes spheroid formation, a spheroid confinement volume.

[0036] As shown in **FIG. 3A**, in some embodiments, a spheroid-promoting cell culture insert **105** can have a first open end **101** and a second end, **102** and one or more sidewalls **110** extending from the first open end to the second end. In some embodiments, the sidewalls are sloped. In one aspect, the second end of the spheroid-promoting cell culture insert **105** contains multiple spheroid-promoting wells **400**, where each spheroid-promoting well may have a sidewall **410**. In some embodiments, the spheroid-promoting cell culture insert **105** can have one or more sidewalls **110** that are non-adherent to cells.

[0037] In some embodiments, the substrate having an array of microwells is comprised of hexagonal close-packed well structures. An image of an embodiment of such a substrate having an array of microwells **410** is shown in **FIG. 3B**, showing the hexagonally shaped wells **400**. **FIG. 3C** is a schematic drawing showing a top-down view of an embodiment of a substrate having an array of microwells **410**. In some preferred embodiments, cells cultured within each well **400** form a single spheroid **200**.

[0038] As shown in **FIG. 3D**, in some embodiments, the wells **400** of the spheroid-promoting cell culture insert **105** have an inner surface that defines an upper aperture and a nadir, or low point or surface. At the upper aperture the wells have a diametric dimension, such as a diameter, a width, a diagonal of a square or rectangle, or the like, d_3 , in a range from 100 μm to 1000 μm . Specifically, the well can have a diametric dimension d_3 of 100 μm , 150 μm , 200 μm , 250 μm , 300 μm , 350 μm , 400 μm , 450 μm , 500 μm , 550 μm , 600 μm , 650 μm , 700 μm , 750 μm , 800 μm , 850 μm , 900 μm , 950 μm , or 1000 μm , and any dimension encompassed within the range from 100 μm to 1000 μm . In some embodiments, the depth of the wells **400** d_4 is 1000 μm , 500 μm , 450 μm , 400 μm , 350 μm , 300 μm , 250 μm , 200 μm , 150 μm , or 100 μm , or any dimension encompassed within the range from 100 μm to 1000 μm .

[0039] In some embodiments, a substrate having an array of microwells with a porous support forming the bottom of the microwells **410** covers the second end of the spheroid-promoting cell culture insert **105**. In some embodiments, at least a portion of the substrate having an array of microwells **410** is non-adherent to cells. In some embodiments, at least a portion of the substrate having an array of microwells **410** is adherent to cells. In some embodiments, a portion of the substrate having an array of microwells **410** is porous. In further embodiments, a portion of the substrate having an array of microwells **410** forming the wells **400** includes openings. In some embodiments, the substrate having an array of microwells **410** can be adhered to, affixed to, or juxtaposed with a porous membrane **420**. In one embodiment, the second end of the spheroid-promoting cell culture insert **105** is covered by a porous membrane **420**, and the porous membrane defines the substrate having an array of microwells **410**.

[0040] In some embodiments, at least a portion of the substrate having an array of microwells **410** forming the wells **400** of the spheroid-promoting cell culture insert **105** are sloped. In some

embodiments, the substrate having an array of microwells **410** forming the wells **400** can be sloped along the entire depth of the well.

[0041] A structured bottom surface as described herein can be formed in any suitable manner. For example, a substrate can be coined, injection molded or embossed to form the substrate having an array of microwells **410**. A porous material or a gas permeable material can be coined, injection molded or embossed to form a substrate having an array of microwells.

[0042] Referring now to **FIGS. 4A-B**, in some embodiments, a spheroid-promoting cell culture insert **100** can be used in a nested permeable support device **600**. In some embodiments, a spheroid-promoting cell culture insert **100** can be placed in another cell culture insert or device or another spheroid-promoting cell culture insert. In one aspect two, or three, or more spheroid-promoting cell culture inserts **100** can be nested. In another aspect, a spheroid-promoting cell culture insert **100** can be placed in another cell culture insert or can have another cell culture insert placed in it. In some embodiments, the spheroid-promoting cell culture insert can further include a ledge extending around the perimeter of the first open end where the ledge is sized to support the spheroid-promoting cell culture insert when it is positioned inside a reservoir or another cell culture insert. One having ordinary skill in the art of cell culture would recognize that any combination of spheroid-promoting cell culture inserts and other cell culture inserts could be constructed. Each cell culture insert can have a porous membrane **120** or can be gas permeable. In one embodiment, the lowest cell culture insert or reservoir is gas-permeable and the upper cell inserts have porous membranes **120**.

[0043] For example, as shown in **FIG. 4A**, a nested device can include an upper **100** and a middle **101** spheroid-promoting cell culture insert. The upper **100** and middle **101** spheroid-promoting cell culture inserts can have a porous membrane **120** at the nadir. In embodiments, the porous membrane is a substrate having an array of microwells. The nested device can further include a spheroid-promoting cell culture reservoir **102** that does not have a permeable support. In some embodiments, the spheroid-promoting cell culture reservoir **102** can be made of or include a portion of a gas-permeable material. In embodiments the gas permeable material is a substrate having an array of microwells.

[0044] As shown in the embodiment shown is **FIG. 4B**, only the middle cell culture insert **101** can be a spheroid-promoting cell culture insert, but both the uppermost cell culture insert **300** and middle spheroid-promoting cell culture insert **101** have porous membranes **120**. The lowest device can be a reservoir **151**. In one embodiment, the reservoir **151** can be gas-permeable.

[0045] As shown in **FIG. 5A**, the middle cell culture insert can be a spheroid-promoting cell culture insert **105** that contains multiple spheroid-promoting porous wells **400**. The uppermost cell culture insert **300** can have a porous membrane **120**. The spheroid-promoting cell culture insert **105** can be inserted in or nested in a reservoir **151**. In one embodiment, the reservoir **151** can be gas-permeable. Using a spheroid-promoting cell culture insert **105** that contains multiple spheroid-promoting wells **400** permits tighter nesting with flat bottomed inserts that culture 2D cell sheets (such as those depicted in **FIG. 4 A&B** and would also provide more spheroids for amplifying signal and the cell processing rate, preventing bottlenecks in a testing system. **Fig. 5B** shows an embodiment of an apparatus with first **105** and second **106** spheroid-promoting cell culture inserts having porous membrane bottoms **120** in a spheroid-promoting reservoir **151** having a non-liquid permeable, gas permeable bottom. In addition to providing greater signal amplification the more physiologic functionality of the spheroids can better approximate a replacement for animal testing. As will be understood by those of ordinary skill in the art, any combination of cell culture supports, each having porous membranes or not, having substrates having an array of microwells for spheroid promotion or not, or being gas permeable or not, are possible depending on the desired cell culture environment.

[0046] In some embodiments, the spheroid-promoting cell culture inserts can be used in a method to determine whether a compound or molecule known as a NCE has a desired biological activity. Such methods are described in, for example, U.S. Patent No. 8,163,537. These methods often entail examining the Absorption, Distribution, Metabolism, Excretion, and Toxicity (ADME-Tox) of the NCE, as well as determining the NCE's level of effectiveness for the targeted therapeutic indication including pharmacokinetic parameters. One type of assessment examines the "first pass effect." This assessment involves experimental determination of the bioavailability of the NCE following its absorption through the digestive tract and then its metabolism by the liver. Commonly, the assessment of the "first pass effect" requires two separate in vitro assays to be conducted, and the data combined, to determine the intestinal permeability and the hepatic metabolism. If desired,

additional studies may be conducted to determine target selectivity, efficacy and dosage (Lau et al., Drug Metabolism and Disposition, Vol. 32, No. 9, pp. 937-942, 2004).

[0047] A well-known method used today to examine the intestinal absorption of a NCE is known as the Caco 2 cell-based assay which is typically conducted on permeable supports such as the ones sold under the brand name of Transwell™ and manufactured by Corning Inc. (“Transwell® Permeable Supports: Including Snapwell™ and Netwell™ Inserts—Instructions for Use” Corning Inc., September 2007.) The design of the Transwell™ permeable support facilitates the development of Caco 2 cell polarization to create more in vivo-like test conditions. Researchers from the Schering-Plough Research Institute have expanded the utility of the Caco 2 cell-based assay by adding hepatocytes in the nutrient medium to a Transwell™ receiver plate which receives the Transwell™ permeable support. In this way, the researchers were able to more accurately predict the oral bioavailability of NCE’s. However, the hepatic cell viability under these conditions during a 3 hour incubation period was only 50-70%, limiting the potential of this method (Lau et al., Drug Metabolism and Disposition, Vol. 32, No. 9, pp. 937-942, 2004). Another group of researchers from the University of Tokyo co-cultured Caco-2 cells on the Transwell™ permeable support with monolayers of Hep G2 cells growing on the inner surface of the Transwell™ receiver plate. While useful for some assays, the Hep G2 cells did not maintain the functions that are representative of in vivo hepatocytes (Choi et al., Toxicology in Vitro, vol. 18, pages 393-402, 2004).

[0048] The current United States Food and Drug Administration Guidance regarding drug interaction studies like the first pass assay recommends the use of in vitro assays with fresh or cryopreserved human hepatocytes due to species specific responses. (U.S. Department of Health and Human Services et al. “Guidance for Industry: Drug Interaction Studies-Study, Design, Data Analysis, and Implications for Dosing and Labeling”, Clinical Pharmacology, September 2006.) However, it is well known that primary hepatocytes lose differentiated function rapidly in standard cell culture conditions on tissue culture treated polystyrene. The loss of normal differentiated hepatocyte function decreases the in vivo-like conditions and hence also decreases the relevance of experimental data in ADME-Tox and pharmacokinetic in vitro assays.

[0049] In some embodiments of the methods described herein, hepatocytes or Hep G2 cells used in a Caco 2 cell-based assay are cultured in a spheroid-promoting cell culture insert.

[0050] In some embodiments, the present disclosure relates to a nested permeable support device and methods for using the nested permeable support device to perform various experiments to test new therapeutic compounds, NBEs, or NCEs.

[0051] In some embodiments, the spheroid-promoting cell culture inserts can be used to assess system-like communication information. In some embodiments, the spheroid-promoting cell culture inserts can be used to create cell models that represent a series of human organs in vertical orientation.

[0052] In one aspect, the nested permeable support device is used to form a first pass assay to determine the bioavailability of a NCE or NBE following absorption from the digestive tract and metabolism by the liver.

[0053] In one embodiment, the nested permeable support device **600** can be used to perform a first pass assay to determine the bioavailability of a NCE following absorption through the digestive tract and metabolism by the liver. In another embodiment, the nested permeable support device **600** can be used to perform a first pass assay to determine the bioavailability of a NBE following absorption through the digestive tract and metabolism by the liver.

[0054] For instance, a researcher using the embodiment shown in Fig. 5A can place a media in a growing reservoir and then place the upper insert **300** in the growing reservoir. The upper insert **300** is then filled with a volume of Caco 2 cells in media. The upper insert **300** and growing reservoir are in communication until a confluent monolayer of Caco 2 cells is formed across the permeable support of the upper insert **300**. It usually takes about a month for Caco 2 cells to form across the permeable support of the upper insert **300**. The Caco 2 cells can be tested electronically to determine how tightly the Caco 2 cells adhere to one another by performing a Trans Epithelial Electrical Resistance (TEER) test, where a probe is inserted into the upper insert **300** and then the probe initiates a pulse that is detected by another probe located in the growing reservoir below the permeable support. Another test that can be performed uses a dye called Lucifer yellow, which can pass through gaps in the Caco 2 cell monolayer. The more Lucifer yellow that shows up in the growing reservoir after being introduced in the upper insert **300**, the less mature (or confluent) the monolayer of Caco 2 cells. Tests such as these can be performed to make sure the Caco 2 cell culture is functioning as expected.

[0055] In parallel, the researcher can place a media in another growing reservoir and then place the middle insert **105** in this growing reservoir. The middle insert **105** is then filled with a volume of hepatocytes in media. The middle insert **105** and reservoir are in communication until a spheroid of hepatocytes is formed across the second permeable support. Tests could also be conducted to assure that the hepatocytes are functioning appropriately. Alternatively, the upper insert **300** and middle insert **105** can be placed in a reservoir **151** to grow the Caco 2 cells and the hepatocytes.

[0056] Once the Caco 2 cells and the hepatocytes have been cultured, the upper and middle inserts **300** and **105** would be lifted out of their respective growing reservoirs. The middle insert **105** would be placed (nested) in the reservoir **151** which contains a media. Some media would then be placed above the layer of hepatocytes located within the middle insert **105**. Then, the upper insert **300** would be placed (nested) in the middle insert **105**. The NCE/NBE and media would be dispensed above the layer of Caco 2 cells located within the upper insert **300**. After a period of incubation, the upper insert **300** could be removed and the media in the middle insert **105** could be tested (i.e., LS/MS) to determine if the NCE/NBE passed through the intestinal epithelium (Caco 2 cells). If the NCE/NBE did pass through the Caco 2 cells, then the middle insert **105** could be removed and the media in the reservoir **151** could be tested (i.e., LC/MS) to check the bioavailability of the NCE and/or how the NCE/NBE is metabolized by the liver (hepatocytes) to form metabolic products. The hepatocytes could also show if the NCE/NBE is toxic at the dosage applied. If there are target cells (or molecules) on the bottom of the reservoir **151**, then these could be examined (i.e., LC/MS) to determine the drug effects either microscopically, or by using an assay that is separate from the Caco 2 cells and hepatocytes by pulling out the inserts **300** and **105**. Alternatively, the target cells (or molecules) on the bottom of the reservoir **151** could be examined using an interrogation system to assess function and viability as described, for example, in U.S. Patent No. 8,163,537. An assay such as this will enable understanding of whether 1) an NCE/NBE can pass through the intestinal epithelium; 2) whether the liver metabolizes or is damaged by an NCE/NBE; and 3) the effect on the target cells of unmodified or liver-metabolized NCE/NBE.

[0057] In another embodiment, the nested permeable support device **100** can be used to test a NCE which would not pass through the digestive tract but instead would enter the body via inhalation in which case the Caco 2 cells would be replaced with nasal mucosal cells, bronchial cells or lung

epithelial cells, etc. In practice, the researcher would typically select the actual cells used in the nested permeable support device **600**.

[0058] In some embodiments, particularly where multiple wells are provided on a second end or where nested supports are employed, multiple spheroids may be grown. In some embodiments, the spheroids are all the same. In other embodiments, two or more different types of spheroids are used (e.g., a co-culture system to, for example, simulate or reconstitute the multicellular functionality of an organ). Where cells are imaged or signal generated from the cells is detected, the response from multiple cells may simultaneously be analyzed or the results from individual cells or groups of cells pooled, as desired.

[0059] Cells cultured in three dimensions, such as spheroids, can exhibit more *in vivo* like functionality than their counterparts cultured in two dimensions as monolayers. In two dimensional cell culture systems, cells can attach to a substrate on which they are cultured. However, when cells are grown in three dimensions, such as spheroids, the cells interact with each other rather than attaching to the substrate. Cells cultured in three dimensions more closely resemble *in vivo* tissue in terms of cellular communication and the development of extracellular matrices. Spheroids thus provide a superior model for cell migration, differentiation, survival, and growth and therefore provide better systems for research, diagnostics, and drug efficacy, pharmacology, and toxicity testing.

[0060] In some embodiments, the devices are configured such that cells cultured in the devices form spheroids. For example, the wells in which cells are grown can be non-adherent to cells to cause the cells in the wells to associate with each other and form spheres. The spheroids expand to size limits imposed by the geometry of the wells. In some embodiments, the wells are coated with an ultra-low binding material to make the wells non-adherent to cells.

[0061] Examples of non-adherent material include perfluorinated polymers, olefins, or like polymers or mixtures thereof. Other examples include agarose, non-ionic hydrogels such as polyacrylamides, polyethers such as polyethylene oxide and polyols such as polyvinyl alcohol, or like materials or mixtures thereof. The combination of, for example, non-adherent wells, well geometry (e.g., size and shape), and/or gravity induce cells cultured in the wells to self-assemble into spheroids. Some spheroids maintain differentiated cell function indicative of a more *in vivo*-

like, response relative to cells grown in a monolayer. Other cells types, such as mesenchymal stromal cells, when cultured as spheroids retain their pluripotency.

[0062] In some embodiments, the systems, devices, and methods herein comprise one or more cells. In some embodiments, the cells are cryopreserved. In some embodiments, the cells are in three dimensional culture. In some such embodiments, the systems, devices, and methods comprise one or more spheroids. In some embodiments, one or more of the cells are actively dividing. In some embodiments, the systems, devices, and methods comprise culture media (e.g., comprising nutrients (e.g., proteins, peptides, amino acids), energy (e.g., carbohydrates), essential metals and minerals (e.g., calcium, magnesium, iron, phosphates, sulphates), buffering agents (e.g., phosphates, acetates), indicators for pH change (e.g., phenol red, bromo-cresol purple), selective agents (e.g., chemicals, antimicrobial agents), etc.). In some embodiments, one or more test compounds (e.g., drug) are included in the systems, devices, and methods.

[0063] A wide variety of cell types may be cultured. In some embodiments, a spheroid contains a single cell type. In some embodiments, a spheroid contains more than one cell type. In some embodiments, where more than one spheroid is grown, each spheroid is of the same type, while in other embodiments, two or more different types of spheroids are grown. Cells grown in spheroids may be natural cells or altered cells (e.g., cell comprising one or more non-natural genetic alterations). In some embodiments, the cell is a somatic cell. In some embodiments, the cell is a stem cell or progenitor cell (e.g., embryonic stem cell, induced pluripotent stem cell) in any desired state of differentiation (e.g., pluripotent, multi-potent, fate determined, immortalized, etc.). In some embodiments, the cell is a disease cell or disease model cell. For example, in some embodiments, the spheroid comprises one or more types of cancer cells or cells that can be induced into a hyper-proliferative state (e.g., transformed cells). Cells may be from or derived from any desired tissue or organ type, including but not limited to, adrenal, bladder, blood vessel, bone, bone marrow, brain, cartilage, cervical, corneal, endometrial, esophageal, gastrointestinal, immune system (e.g., T lymphocytes, B lymphocytes, leukocytes, macrophages, and dendritic cells), liver, lung, lymphatic, muscle (e.g., cardiac muscle), neural, ovarian, pancreatic (e.g., islet cells), pituitary, prostate, renal, salivary, skin, tendon, testicular, and thyroid. In some embodiments, the cells are mammalian cells (e.g., human, mice, rat, rabbit, dog, cat, cow, pig, chicken, goat, horse, etc.).

[0064] The cultured cells find use in a wide variety of research, diagnostic, drug screening and testing, therapeutic, and industrial applications.

[0065] In some embodiments, the cells are used for production of proteins or viruses. Systems, devices, and methods that culture large numbers of spheroids in parallel are particularly effective for protein production. Three-dimensional culture allows for increased cell density, and higher protein yield per square centimeter of cell growth surface area. Any desired protein or viruses for vaccine production may be grown in the cells and isolated or purified for use as desired. In some embodiments, the protein is a native protein to the cells. In some embodiments, the protein is non-native. In some embodiments, the protein is expressed recombinantly. Preferably, the protein is overexpressed using a non-native promoter. The protein may be expressed as a fusion protein. In some embodiments, a purification or detection tag is expressed as a fusion partner to a protein of interest to facilitate its purification and/or detection. In some embodiments, fusions are expressed with a cleavable linker to allow separation of the fusion partners after purification.

[0066] In some embodiments, the protein is a therapeutic protein. Such proteins include, but are not limited to, proteins and peptides that replace a protein that is deficient or abnormal (e.g., insulin), augment an existing pathway (e.g., inhibitors or agonists), provide a novel function or activity, interfere with a molecule or organism, or deliver other compounds or proteins (e.g., radionuclides, cytotoxic drugs, effector proteins, etc.). In some embodiments, the protein is an immunoglobulin such as an antibody (e.g., monoclonal antibody) of any type (e.g., humanized, bi-specific, multi-specific, etc.). Therapeutic protein categories include, but are not limited to, antibody-based drugs, Fc fusion proteins, anticoagulants, antigens, blood factor, bone morphogenetic proteins, engineered protein scaffolds, enzymes, growth factors, hormones, interferons, interleukins, and thrombolytics. Therapeutic proteins may be used to prevent or treat cancers, immune disorders, metabolic disorders, inherited genetic disorders, infections, and other diseases and conditions.

[0067] In some embodiments, the protein is a diagnostic protein. Diagnostic proteins include, but are not limited to, antibodies, affinity binding partners (e.g., receptor-binding ligands), inhibitors, antagonists, and the like. In some embodiments, the diagnostic protein is expressed with or is a detectable moiety (e.g., fluorescent moiety, luminescent moiety (e.g., luciferase), colorimetric moiety, etc.).

[0068] In some embodiments, the protein is an industrial protein. Industrial proteins include, but are not limited to, food components, industrial enzymes, agricultural proteins, analytical enzymes, etc.

[0069] In some embodiments, the cells are used drug discovery, characterization, efficacy testing, and toxicity testing. Such testing includes, but is not limited to, pharmacological effect assessment, carcinogenicity assessment, medical imaging agent characteristic assessment, half-life assessment, radiation safety assessment, genotoxicity testing, immunotoxicity testing, reproductive and developmental testing, drug interaction assessment, dose assessment, adsorption assessment, disposition assessment, metabolism assessment, elimination studies, etc. Specific cells types may be employed for specific tests (e.g., hepatocytes for liver toxicity, renal proximal tubule epithelial cells for nephrotoxicity, vascular endothelial cells for vascular toxicity, neuronal and glial cells for neurotoxicity, cardiomyocytes for cardiotoxicity, skeletal myocytes for rhabdomyolysis, etc.). Treated cells may be assessed for any number of desired parameters including, but not limited to, membrane integrity, cellular metabolite content, mitochondrial functions, lysosomal functions, apoptosis, genetic alterations, gene expression differences, and the like.

[0070] In some embodiments, the cell culture devices are a component of a larger system. In some embodiments, the system comprises a plurality (e.g., 2, 3, 4, 5, ..., 10, ..., 20, ..., 50, ..., 100, ..., 1000, etc.) of such cell culture devices. In some embodiments, the system comprises an incubator for maintaining the culture devices at optimal culture conditions (e.g., temperature, atmosphere, humidity, etc.). In some embodiments, the system comprises detectors for imaging or otherwise analyzing cells. Such detectors include, but are not limited to, fluorimeters, luminometers, cameras, microscopes, plate readers (e.g., PERKIN ELMER ENVISION plate reader; PERKIN ELMER VIEWLUX plate reader), cell analyzers (e.g., GE IN Cell Analyzer 2000 and 2200; THERMO/CELLOMICS CELLNSIGHT High Content Screening Platform), and confocal imaging systems (e.g., PERKIN ELMER OPERAPHENIX high throughput content screening system; GE INCELL 6000 Cell Imaging System). In some embodiments, the system comprises perfusion systems or other components for supplying, re-supplying, and circulating culture media or other components to cultured cells. In some embodiments, the system comprises robotic components (e.g., pipettes, arms, plate movers, etc.) for automating the handling, use, and/or analysis of culture devices.

[0071] A number of aspects of inserts, methods and assemblies have been disclosed herein. A summary of some selected aspects is presented below. In a first aspect, a cell culture insert comprises (i) a body having a first open end, a second end wherein the second end defines an opening having a diametric dimension in a range from 100 μm to 1000 μm , and one or more sidewalls extending from the first open end to the second end; wherein the one or more sidewalls are sloped; and (ii) a porous membrane disposed over the opening of the second end.

[0072] A second aspect is a cell culture insert according the first aspect wherein at least a portion of the one or more sidewalls are non-adherent to cells.

[0073] A third aspect is a cell culture insert according to aspect 1 or aspect 2, wherein at least a portion of the porous membrane is non-adherent to cells.

[0074] A fourth aspect is a cell culture insert according to any one of aspects 1 to 3, wherein at least a portion of the porous membrane is adherent to cells.

[0075] A fifth aspect is a cell culture insert according to any one of aspects 1 to 4, wherein a portion of the one or more sidewalls proximate the second end at least partially define a cell confinement volume.

[0076] A sixth aspect is a cell culture insert according to aspect 5 wherein a depth of the confinement volume is in a range from 100 μm to 1000 μm .

[0077] A seventh aspect is a cell culture insert according to any one of aspects 1 to 6, wherein the insert is configured such that cells cultured in the insert form a spheroid.

[0078] An eighth aspect is a method for culturing a spheroid comprising (i) placing cell culture insert according to aspect 7 in a reservoir, the reservoir having a bottom, wherein insert is placed in the reservoir such that the second end of body of the insert is positioned above the bottom of the insert; (ii) introducing cells into the insert; (iii) introducing a cell culture medium into the insert; and (iv) culturing the cells in the cell culture medium in the insert to form the spheroid.

[0079] A ninth aspect is a cell culture assembly, comprising (i) a reservoir defining an interior and having a bottom; and (ii) a first cell culture insert according to any one of aspects 1 to 7 configured

to be positioned in the interior of the reservoir such that the second end of the body is above the bottom of the reservoir, wherein the body of the first insert defines an interior of the first insert.

[0080] A tenth aspect is a cell culture assembly according to aspect 9, wherein the interior of the first insert, when the first insert is positioned in the interior of the reservoir, is in fluid communication with the interior of the reservoir only through the porous membrane disposed over the opening of the second end of the body of the first insert.

[0081] An eleventh aspect is a cell culture assembly according to aspect 9 or aspect 10, further comprising a second insert having a body defining an interior, the body comprising a first open end, a second end defining an opening, and one or more sidewalls extending from the first open end to the second end, wherein the second insert is configured to be positioned in the interior of the first insert such that the second end of the body of the second insert is above the second end of the body of the first insert.

[0082] A twelfth aspect is a cell culture assembly according to aspect 11, wherein the interior of the second insert, when the second insert is positioned in the interior of the first insert, is in fluid communication with the interior of the first insert only through the porous membrane disposed over the opening of the second end of the body of the second insert.

[0083] A thirteenth aspect is a method comprising (i) introducing target cells and a cell culture medium to an interior of a reservoir of a cell culture assembly according to aspect 12 such that the target cells grow on the bottom of the reservoir; (ii) positioning a first cell culture insert according to aspect 12 in the interior of the reservoir; (iii) introducing a plurality of a first type of cells and a cell culture medium into the interior of the first cell culture insert such that cells of the first type grow as a spheroid in proximity to the porous membrane of the first insert; (iv) positioning a second cell culture insert according to aspect 12 in the interior of the first insert; and (v) introducing a plurality of a second type of cells and a cell culture medium into the interior of the second cell culture insert such that the cells of the second type grow in proximity to the porous membrane of the second insert.

[0084] A fourteenth aspect is a method according to aspect 13, wherein the cells of the second type cover the porous membrane of the second insert such that compounds or metabolic derivatives

thereof that move from the interior of the second insert to the interior of the first insert pass through the cells of the second type.

[0085] A fifteenth aspect is a method according to aspect 14, wherein the cells of the first type attach to the porous membrane of the first insert such that compounds or metabolic derivatives thereof that move from the interior of the first insert to the interior of the reservoir pass through the cells of the first type.

[0086] A sixteenth aspect is a method according to aspect 15, further comprising: (i) introducing a test compound to the interior of the second insert; and (ii) identifying an effect of the test compound or a metabolic derivative thereof on the target cells.

[0087] A seventeenth aspect is a method according to any of aspects 13 to 16, wherein the cells of the first type are hepatocytes.

[0088] An eighteenth aspect is a method according to any of aspects 13 to 17, wherein the cells of the second type are Caco 2 cells.

[0089] A nineteenth aspect is a cell culture insert comprising: (i) a body having a first open end, a second end wherein the second end defines an opening, and one or more sidewalls extending from the first open end to the second end; wherein the one or more sidewalls are sloped; and (ii) a porous membrane disposed over the opening of the second end, wherein the porous membrane is non-adherent to cells.

[0090] A twentieth aspect is a permeable support device configured to be at least partially inserted into a reservoir of a cell culture device, the permeable support device comprising a first well having a tapered shape and bottom at least partially defined by a first permeable support.

[0091] A twenty-first aspect is a permeable support device of aspect 20 wherein the well is configured such that cells cultured in the well form a spheroid.

[0092] A twenty-second aspect is a permeable support device of either of aspects 20 or 21 wherein at least a portion of the first well is coated with an ultra-low binding material.

[0093] A twenty-third aspect is a permeable support device of any of aspect 20 to 22, wherein at least a portion of the permeable support is configured to attach to cells cultured in the first well.

[0094] A twenty-fourth aspect is a permeable support device of any of aspects 20 to 23 wherein at least a portion of the first well comprises an arcuate shape

[0095] A twenty-fifth aspect is a permeable support device of any of aspects 20 to 24 wherein at least a portion of the first well comprises a conical shape.

[0096] A twenty-sixth aspect is a permeable support device of any of aspects 20 to 25 wherein a portion of the well defines a confinement volume.

[0097] A twenty-seventh aspect is a permeable support device of aspect 26 wherein a diametric dimension of the confinement volume is in a range from 200 μm to 500 μm .

[0098] A twenty-eighth aspect The permeable support device of either of aspects 26 or 27 wherein the depth of the confinement volume is in a range from 100 μm to 500 μm .

[0099] A twenty-ninth aspect is a permeable support device of aspect any of aspects 20 to 28 wherein the first well is configured and sized to receive a second well having a bottom, wherein the second well is located above the first well.

[00100] A thirtieth aspect is a nested permeable support device comprising: (i) a first well having a tapered shape and a bottom portion at least partially defined by a first permeable support; and (ii) a reservoir having a bottom located below the first well.

[00101] A thirty-first aspect is a nested permeable support device of aspect 30 wherein the well is configured such that cells cultured in the well form a spheroid.

[00102] A thirty-second aspect is a nested permeable support device of either of aspects 30 or 31 wherein at least a portion of the first well is coated with an ultra-low binding material.

[00103] A thirty-third aspect is a nested permeable support device of any of aspects 29 to 32, wherein at least a portion of the permeable support is configured to attach to cells cultured in the first well.

[00104] A thirty-fourth aspect is a nested permeable support device of any of aspects 30 to 33 wherein at least a portion of the first well comprises an arcuate shape.

[00105] A thirty-fifth aspect is a nested permeable support device of any of aspects 30 to 34 wherein at least a portion of the first well comprises a conical shape.

[00106] A thirty-sixth aspect is a nested permeable support device of any of aspects 30 to 35 wherein a portion of the well defines a confinement volume.

[00107] A thirty-seventh aspect is a nested permeable support device of aspect 36 wherein a diametric dimension of the confinement volume is in a range from 100 μm to 1000 μm , e.g., 100, 150, 200, 250, 300, 350, 400, 450, 500, 550, 600, 650, 700, 750, 800, 850, 900, 950, or 1000 μm , including ranges between any of the foregoing.

[00108] A thirty eighth aspect is a nested permeable support device of either of aspects 36 or 37 wherein the depth of the confinement volume is in a range from 100 μm to 1000 μm , e.g., 100, 150, 200, 250, 300, 350, 400, 450, 500, 550, 600, 650, 700, 750, 800, 850, 900, 950, or 1000 μm , including ranges between any of the foregoing.

[00109] A thirty-ninth aspect is a nested permeable support device of any of aspects 30 to 38 further comprising a second well having a bottom at least partially defined by a second permeable support, and wherein the first well and the first permeable support are located below the second well and the second permeable support.

[00110] A fortieth aspect is a nested permeable support device of aspect 39 wherein the second well comprises a tapered shape.

[00111] A forty-first aspect is a nested permeable support device of any of aspect 30 to 40 wherein the bottom of the reservoir comprises a gas permeable material.

[00112] A forty-second aspect is a nested permeable support device comprising: (i) a first well having a bottom, wherein at least a portion of the bottom is formed by a first permeable support; (ii) a second well having a bottom, wherein the bottom of the second well comprises an arcuate shape and at least a portion of the bottom is formed by a second permeable support, and wherein the second well and the second permeable support are located below the first well and the

first permeable support; and (ii) a third well having a bottom which is located below the second well and the second permeable support.

[00113] A forty-third aspect is a nested permeable support device of aspect 42 wherein at least a portion of the second well is coated with an ultra-low binding material.

[00114] A forty-fourth aspect is a cell culture insert comprising a body having a first open end, a second end, and one or more sidewalls extending from the first open end to the second end; and wherein the second end comprises a substrate having an array of microwells defining wells, wherein at least a portion of a substrate having an array of microwells defining a well is sloped.

[00115] A forty-fifth aspect is a cell culture insert of aspect 44 wherein the sidewalls are sloped.

[00116] A forty-sixth aspect is a cell culture insert of either of aspect 44 or 45 wherein the sidewalls are non-adherent to cells.

[00117] A forty-seventh aspect is a cell culture insert of any of aspects 44 to 46 wherein at least a portion of the substrate having an array of microwells is non-adherent to cells.

[00118] A forty-eighth aspect is a cell culture insert of any of aspects 44 to 47 wherein the wells have an inner surface defining an upper aperture and wherein the wells have a diametric dimension at the upper aperture in a range from 100 μm to 1000 μm .

[00119] A forty-ninth aspect is a cell culture insert of any of aspects 44 to 48 wherein the wells have a depth in a range from 100 μm to 100 μm .

[00120] A fiftieth aspect is a cell culture insert of any of aspects 44 to 49 wherein at least a portion of the substrate having an array of microwells is non-adherent to cells.

[00121] A fifty-first aspect is a cell culture insert of any of aspects 44 to 49 wherein at least a portion of the substrate having an array of microwells is adherent to cells.

[00122] A fifty-second aspect is a cell culture insert of any of aspects 44 to 51 wherein at least a portion of the substrate having an array of microwells is porous.

[00123] A fifty-third aspect is a cell culture insert of any of aspects 44 to 52 wherein the substrate having an array of microwells comprises openings.

[00124] A fifty-fourth aspect is a cell culture insert of any of aspects 44 to 53 wherein the substrate having an array of microwells is adhered to, affixed to, or juxtaposed with a porous membrane.

[00125] A fifty-fifth aspect is a cell culture insert of any of aspects 44 to 54 wherein the second end is covered by a porous membrane.

[00126] A fifty-sixth aspect is a cell culture insert of any of aspects 44 to 55 wherein the substrate having an array of microwells comprises a sloped surface.

[00127] A fifty-seventh aspect is a cell culture insert of any of aspects 44 to 56 wherein the substrate having an array of microwells comprises an array of hexagonal structures.

[00128] A fifty-eighth aspect is a cell culture assembly, comprising: (i) a reservoir defining an interior and having a bottom; and (ii) a first cell culture insert according to any one of aspects 44-57 configured to be positioned in the interior of the reservoir such that the second end of the body is above the bottom of the reservoir, wherein the body of the first insert defines an interior of the first insert.

[00129] A fifty-ninth aspect is a cell culture assembly according to aspect 58, wherein the interior of the first insert, when the first insert is positioned in the interior of the reservoir, is in fluid communication with the interior of the reservoir only through the porous membrane disposed over the opening of the second end of the body of the first insert.

[00130] A sixtieth aspect is a cell culture assembly according to aspect 58 or aspect 59, further comprising a second insert having a body defining an interior, the body comprising a first open end, a second end defining an opening, and one or more sidewalls extending from the first open end to the second end, wherein the second insert is configured to be positioned in the interior of the first insert such that the second end of the body of the second insert above the second end of the body of the first insert.

[00131] A sixty first aspect is a cell culture assembly according to aspect 60, wherein the interior of the second insert, when the second insert is positioned in the interior of the first insert, is in fluid communication with the interior of the first insert only through the porous membrane disposed over the opening of the second end of the body of the second insert.

[00132] A sixty second aspect is a cell culture insert comprising: a body sized for insert into a reservoir of a cell culture device, said body having a first open end, a second end having a porous membrane, and one or more sidewalls extending from the first open end to the second end; wherein the one or more sidewalls are sloped; and wherein said second end has an upper surface defining a plurality of microwells sized for spheroid growth.

[00133] A sixty third aspect is the cell culture insert of aspect 62, wherein said microwells each have a diameter in a range from 100 μm to 1000 μm .

[00134] Unless otherwise expressly stated, it is in no way intended that any method set forth herein be construed as requiring that its steps be performed in a specific order. Accordingly, where a method claim does not actually recite an order to be followed by its steps or it is not otherwise specifically stated in the claims or descriptions that the steps are to be limited to a specific order, it is no way intended that any particular order be inferred. Any recited single or multiple feature or aspect in any one claim can be combined or permuted with any other recited feature or aspect in any other claim or claims.

[00135] It is also noted that recitations herein refer to a component being “configured” or “adapted to” function in a particular way. In this respect, such a component is “configured” or “adapted to” embody a particular property, or function in a particular manner, where such recitations are structural recitations as opposed to recitations of intended use. More specifically, the references herein to the manner in which a component is “configured” or “adapted to” denotes an existing physical condition of the component and, as such, is to be taken as a definite recitation of the structural characteristics of the component.

[00136] While various features, elements or steps of particular embodiments may be disclosed using the transitional phrase “comprising,” it is to be understood that alternative embodiments, including those that may be described using the transitional phrases “consisting” or “consisting essentially of,” are implied. Thus, for example, implied alternative embodiments to a

cell culture insert comprising body and a porous membrane include embodiments where a cell culture insert consists of a body and a porous membrane and embodiments where a cell culture insert consists essentially of a body and a porous membrane.

[00137] It will be apparent to those skilled in the art that various modifications and variations can be made to the present inventive technology without departing from the spirit and scope of the disclosure. Since modifications, combinations, sub-combinations and variations of the disclosed embodiments incorporating the spirit and substance of the inventive technology may occur to persons skilled in the art, the inventive technology should be construed to include everything within the scope of the appended claims and their equivalents

[00138] In the event that any inconsistency exists between the disclosure of the present application and the disclosure(s) of any document incorporated herein by reference, the disclosure of the present application shall govern. The foregoing detailed description and examples have been given for clarity of understanding only. No unnecessary limitations are to be understood therefrom. The embodiments are not limited to the exact details shown and described, for variations obvious to one skilled in the art will be included within the embodiments defined by the claims.

[00139] Unless otherwise indicated, all numbers expressing quantities of components, molecular weights, and so forth used in the specification and claims are to be understood as being modified in all instances by the term "about." Accordingly, unless otherwise indicated to the contrary, the numerical parameters set forth in the specification and claims are approximations that may vary depending upon the desired properties sought to be obtained. At the very least, and not as an attempt to limit the doctrine of equivalents to the scope of the claims, each numerical parameter should at least be construed in light of the number of reported significant digits and by applying ordinary rounding techniques.

[00140] Notwithstanding that the numerical ranges and parameters are approximations, the numerical values set forth in the specific examples are reported as precisely as possible. All numerical values, however, inherently contain a range necessarily resulting from the standard deviation found in their respective testing measurements.

[00141] Any direction referred to herein, such as "top," "bottom," "left," "right," "upper," "lower," "above," "below," and other directions and orientations are described herein for clarity in

reference to the figures and are not to be limiting of an actual device or system or use of the device or system. Many of the devices, articles or systems described herein may be used in a number of directions and orientations. Directional descriptors used herein with regard to cell culture apparatuses often refer to directions when the apparatus is oriented for purposes of culturing cells in the apparatus.

[00142] The words “preferred” and “preferably” refer to embodiments that may afford certain benefits, under certain circumstances. However, other embodiments may also be preferred, under the same or other circumstances. Furthermore, the recitation of one or more preferred embodiments does not imply that other embodiments are not useful, and is not intended to exclude other embodiments.

[00143] As used herein, “have”, “has”, “having”, “include”, “includes”, “including”, “comprise”, “comprises”, “comprising” or the like are used in their open ended inclusive sense, and generally mean “include, but not limited to”, “includes, but not limited to”, or “including, but not limited to”.

[00144] “Optional” or “optionally” means that the subsequently described event, circumstance, or component, can or cannot occur, and that the description includes instances where the event, circumstance, or component, occurs and instances where it does not.

[00145] Unless otherwise specified, “a,” “an,” “the,” and “at least one” are used interchangeably and mean one or more than one.

[00146] Also herein, the recitations of numerical ranges by endpoints include all numbers subsumed within that range (e.g., 1 to 5 includes 1, 1.5, 2, 2.75, 3, 3.80, 4, 5, etc.). Ranges can be expressed herein as from “about” one particular value, and/or to “about” another particular value. When such a range is expressed, examples include from the one particular value and/or to the other particular value. Similarly, when values are expressed as approximations, by use of the antecedent “about,” it will be understood that the particular value forms another aspect. It will be further understood that the endpoints of each of the ranges are significant both in relation to the other endpoint, and independently of the other endpoint.

[00147] For any method disclosed herein that includes discrete steps, the steps may be conducted in any feasible order. And, as appropriate, any combination of two or more steps may be conducted simultaneously.

[00148] A number of abbreviations are used herein. A listing of some of those abbreviations and their meaning are presented below:

ADME-Tox – Absorption, Distribution, Metabolism, Excretion, and Toxicity

NBE – New Biological Entity

NCE – New Chemical Entity

TEER – Trans Epithelial Electrical Resistance

[00149] All headings are for the convenience of the reader and should not be used to limit the meaning of the text that follows the heading, unless so specified.

What is claimed is:

1. A cell culture insert comprising:
a body sized for insert into a reservoir of a cell culture device, said body having a first open end, a second end defining an opening, and one or more sidewalls extending from the first open end to the second end; wherein the one or more sidewalls are sloped; and
a porous membrane disposed over the opening of the second end.
2. A cell culture insert according to claim 1, wherein said opening of said second end has a diametric dimension in a range from 100 μm to 1000 μm .
3. A cell culture insert according to claim 2, wherein said opening of said second end has a diametric dimension in a range from 200 μm to 750 μm .
4. A cell culture insert according to any one of claims 1-3 wherein the porous membrane comprises an array of microwells.
5. A cell culture insert according to claim 1 wherein at least a portion of the one or more sidewalls are non-adherent to cells.
6. A cell culture insert according to any one of claims 1 to 5, wherein at least a portion of the porous membrane is non-adherent to cells.
7. A cell culture insert according to any one of claims 1 to 6, wherein at least a portion of the porous membrane is adherent to cells.

8. A cell culture insert according to any one of claims 1 to 7, wherein a portion of the one or more sidewalls proximate the second end at least partially define a spheroid confinement volume.
9. A cell culture insert according to claim 8 wherein a depth of the confinement volume is in a range from 100 μm to 500 μm .
10. A cell culture insert according to any one of claims 1 to 9, wherein the insert is configured to promote spheroid formation of cells cultured in the insert.
11. A cell culture assembly, comprising:
a reservoir defining an interior and having a bottom; and
a first cell culture insert according to any one of claims 1 to 10 configured to be positioned in the interior of the reservoir to retain the second end of the body above the bottom of the reservoir, wherein the body of the first insert defines an interior of the first insert.
12. A cell culture assembly according to claim 11, wherein the interior of the first insert, when the first insert is positioned in the interior of the reservoir, is in fluid communication with the interior of the reservoir only through the porous membrane disposed over the opening of the second end of the body of the first insert.
13. A cell culture assembly according to claim 11 or claim 12, further comprising a second insert having a body defining an interior, the body comprising a first open end, a second end defining an opening, and one or more sidewalls extending from the first open end to the second end, wherein the second insert is configured to be positioned in the interior of the first insert to retain the second end of the body of the second insert above the second end of the body of the first insert.

14. A cell culture assembly according to claim 13, wherein the interior of the second insert, when the second insert is positioned in the interior of the first insert, is in fluid communication with the interior of the first insert only through the porous membrane disposed over the opening of the second end of the body of the second insert.

15. A method comprising:

introducing target cells and a cell culture medium to an interior of a reservoir of a cell culture assembly according to any one of claims 11-14 to grow the target cells on the bottom of the reservoir;

positioning a first cell culture insert in the interior of the reservoir;

introducing a plurality of a first type of cells and a cell culture medium into the interior of the first cell culture insert to grow the cells of the first type as a spheroid in proximity to the porous membrane of the first insert;

positioning a second cell culture insert in the interior of the first insert;

introducing a plurality of a second type of cells and a cell culture medium into the interior of the second cell culture insert to grow the cells of the second type in proximity to the porous membrane of the second insert.

16. A method according to claim 15, wherein the cells of the second type cover the porous membrane of the second insert such that compounds or metabolic derivatives thereof that move from the interior of the second insert to the interior of the first insert pass through the cells of the second type.

17. A method according to claim 15, wherein the cells of the first type attach to the porous membrane of the first insert such that compounds or metabolic derivatives thereof that move from the interior of the first insert to the interior of the reservoir pass through the cells of the first type.

18. A method according to any one of claims 15-17, further comprising:
introducing a test compound to the interior of the second insert; and
identifying an effect of the test compound or a metabolic derivative thereof on the target cells.
19. A method according to any of claims 15 to 18, wherein the cells of the first type are hepatocytes.
20. A method according to any of claims 15 to 19, wherein the cells of the second type are Caco 2 cells.
21. A cell culture insert comprising:
a body having a first open end, a second end wherein the second end defines an opening, and one or more sidewalls extending from the first open end to the second end; wherein the one or more sidewalls are sloped; and
a porous membrane disposed over the opening of the second end, wherein the porous membrane is non-adherent to cells and wherein the porous membrane comprises an array of microwells.
22. The cell culture insert of claim 21 wherein at least a portion of a microwell in the array of microwells is coated with an ultra-low binding material.
23. The cell culture insert of any of claims 21 or 22, wherein at least a portion of the permeable support is configured to attach to cells cultured in the array of microwells.
24. The cell culture insert of any of claims 21-23 wherein at least a portion of a microwell comprises an arcuate shape.

25. The cell culture insert of any of claims 21 - 24 wherein at least a portion microwell comprises an conical shape.
26. The cell culture insert of any of claims 21-25 wherein a portion of the microwell defines a confinement volume.
27. The cell culture insert of claim 26 wherein a diametric dimension of the confinement volume is in a range from 200 μm to 500 μm .
28. A cell culture insert comprising:
a body having a first open end, a second end, and one or more sidewalls extending from the first open end to the second end; and
wherein the second end comprises a substrate having an array of microwells.
29. The cell culture insert of claim 28 wherein the sidewalls are sloped.
30. The cell culture insert of either of claims 28 or 29 wherein the sidewalls are non-adherent to cells.
31. The cell culture insert of any one of claims 28-30 wherein at least a portion of the substrate having an array of microwells is non-adherent to cells.
32. The cell culture insert of any one of claims 28-31 wherein the wells have an inner surface defining an upper aperture and wherein the wells have a diametric dimension at the upper aperture in a range from 100 μm to 1000 μm .

33. The cell culture insert of any one of claims 28-32 wherein the wells have a depth in a range from 100 μm to 500 μm .
34. The cell culture insert of any one of claims 28-33 wherein at least a portion of the substrate having an array of microwells is non-adherent to cells.
35. The cell culture insert of any one claims 28-34 wherein at least a portion of the substrate having an array of microwells is adherent to cells.
36. The cell culture insert of any one of claims 28-35 wherein at least a portion of the substrate having an array of microwells is porous.
37. The cell culture insert of any one of claims 28-36 wherein the substrate having an array of microwells comprises openings.
38. The cell culture insert of any one of claims 28-37 wherein the substrate having an array of microwells is adhered to, affixed to, or juxtaposed with a porous membrane.
39. The cell culture insert of any one of claims 28-38 wherein the second end is covered by a porous membrane.
40. The cell culture insert of any one of claims 28-39 wherein the substrate having an array of microwells comprises a sloped surface.

41. The cell culture insert of any one of claims 28-40 wherein the substrate having an array of microwells comprises an array of hexagonal structures.

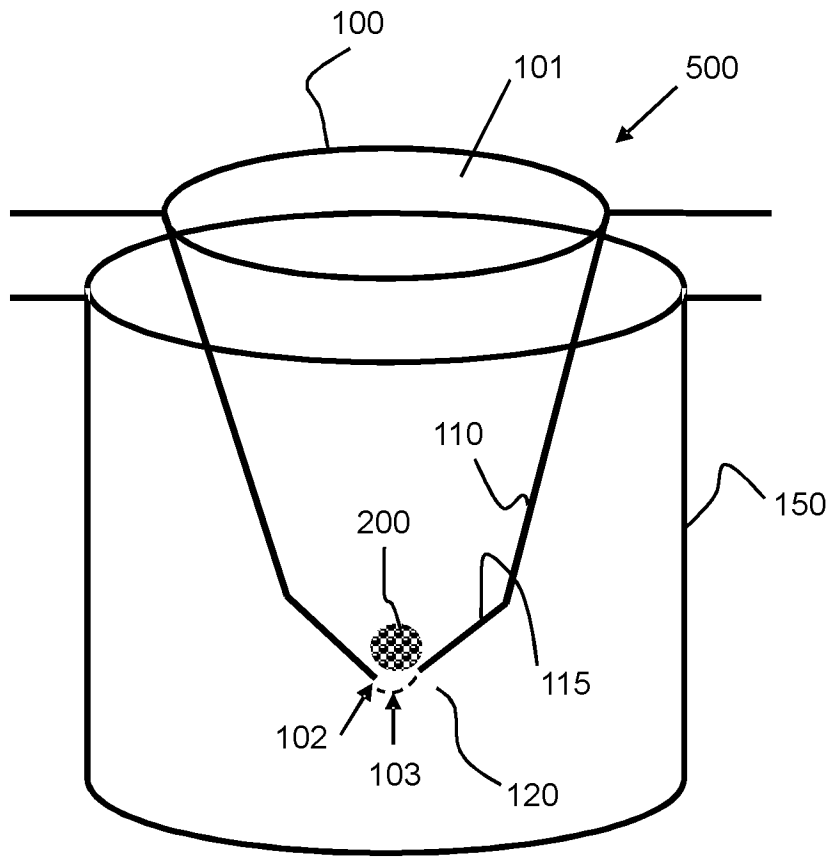

FIG. 1A

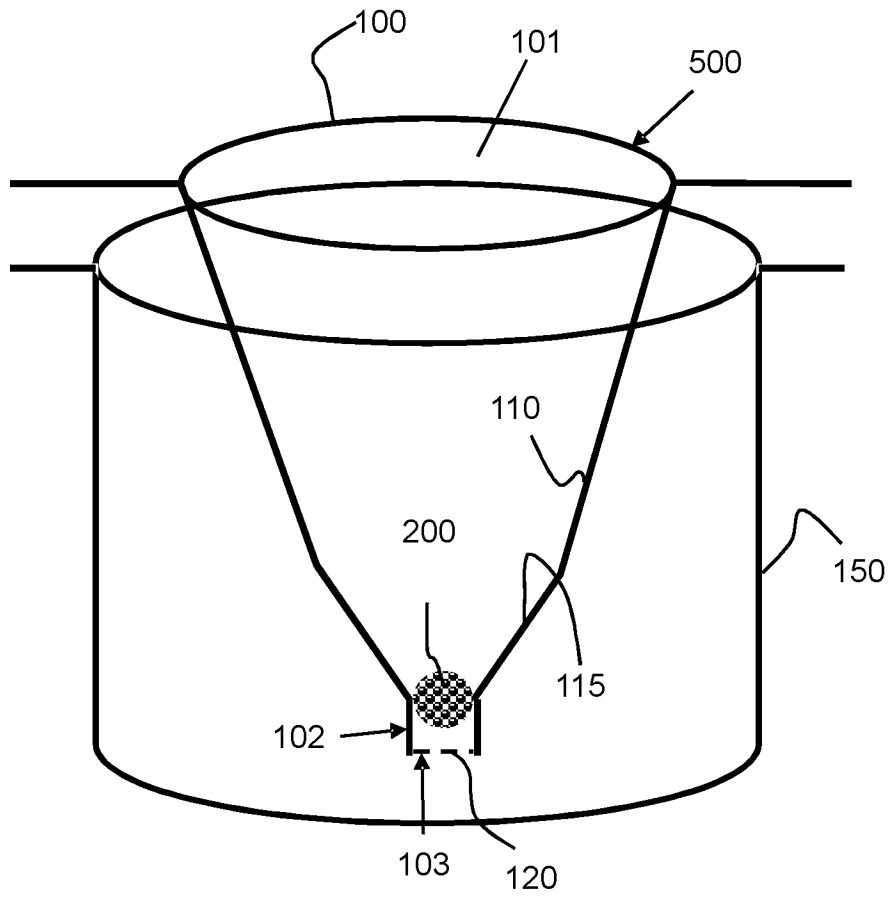

FIG. 1B

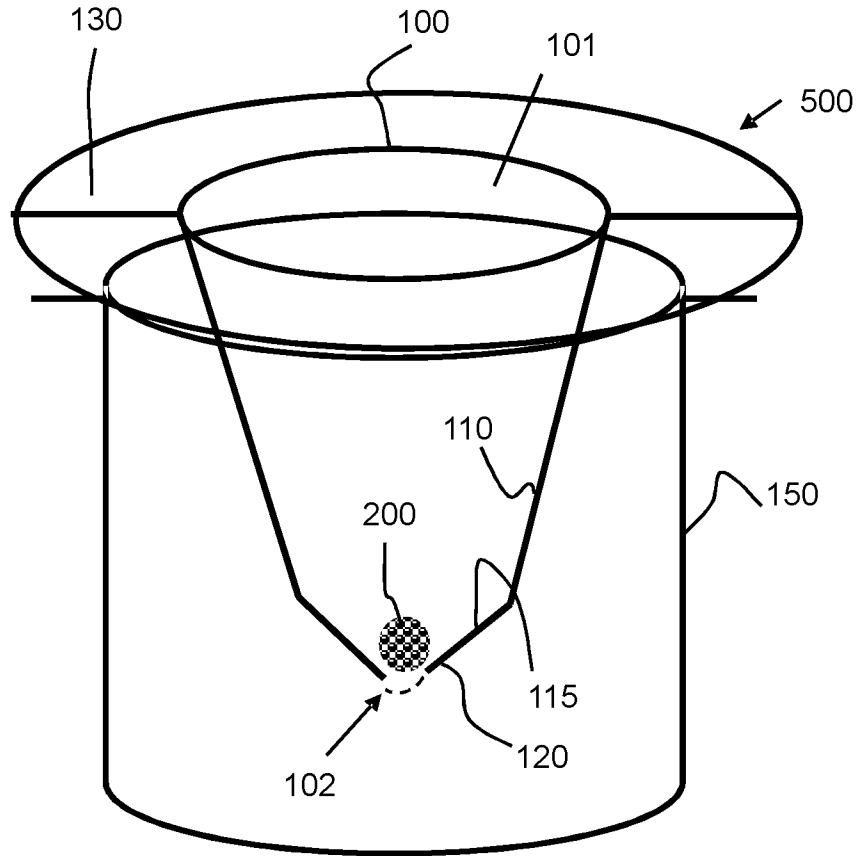

FIG. 1C

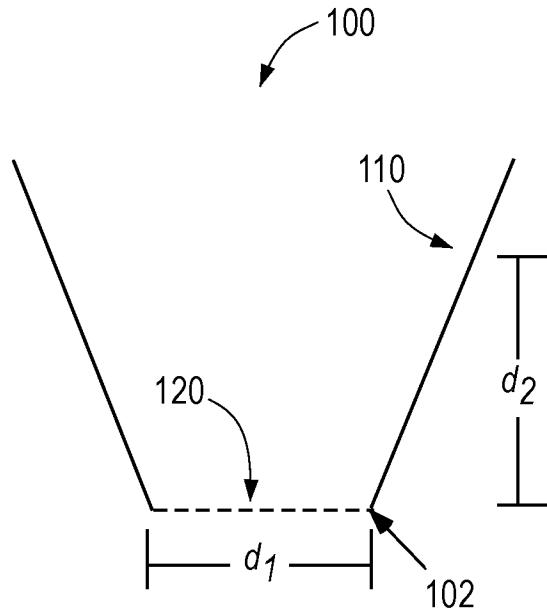

FIG. 2A

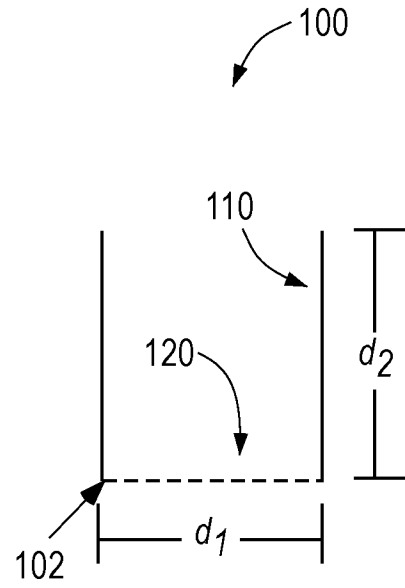

FIG. 2B

FIG. 3A

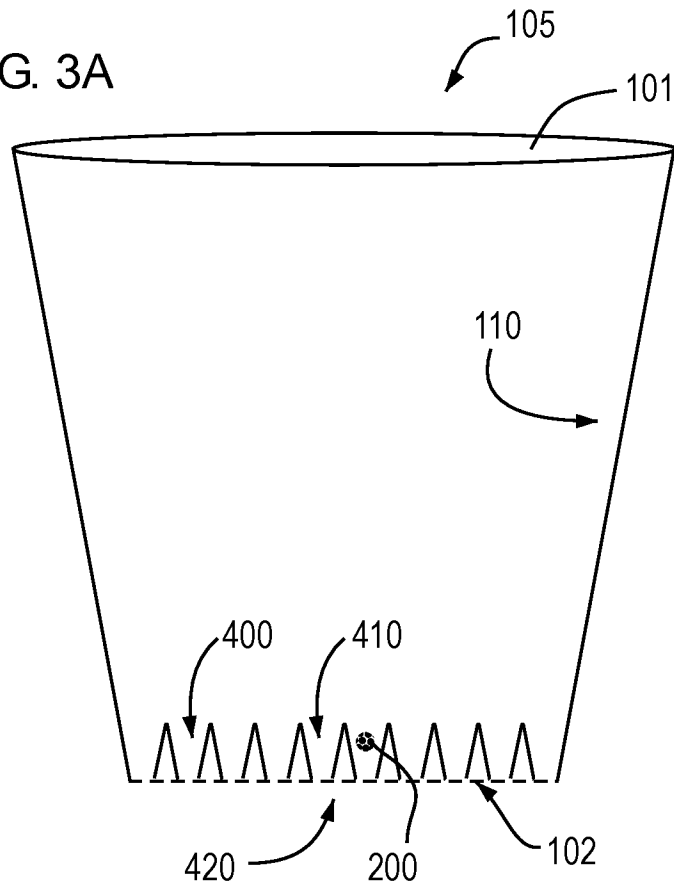

FIG. 3B

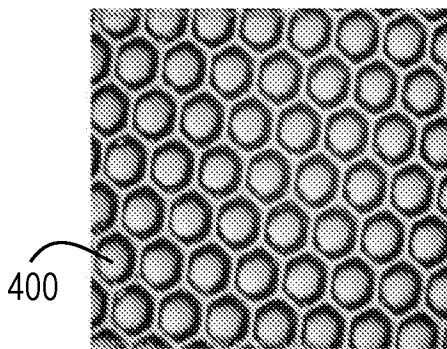

FIG. 3C

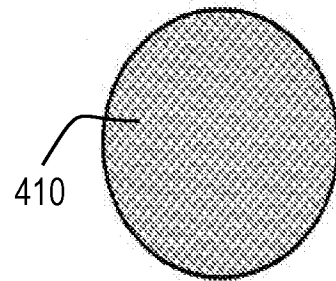
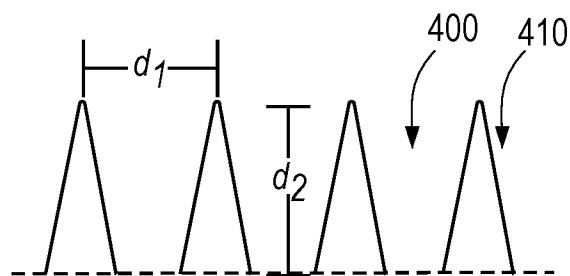

FIG. 3D



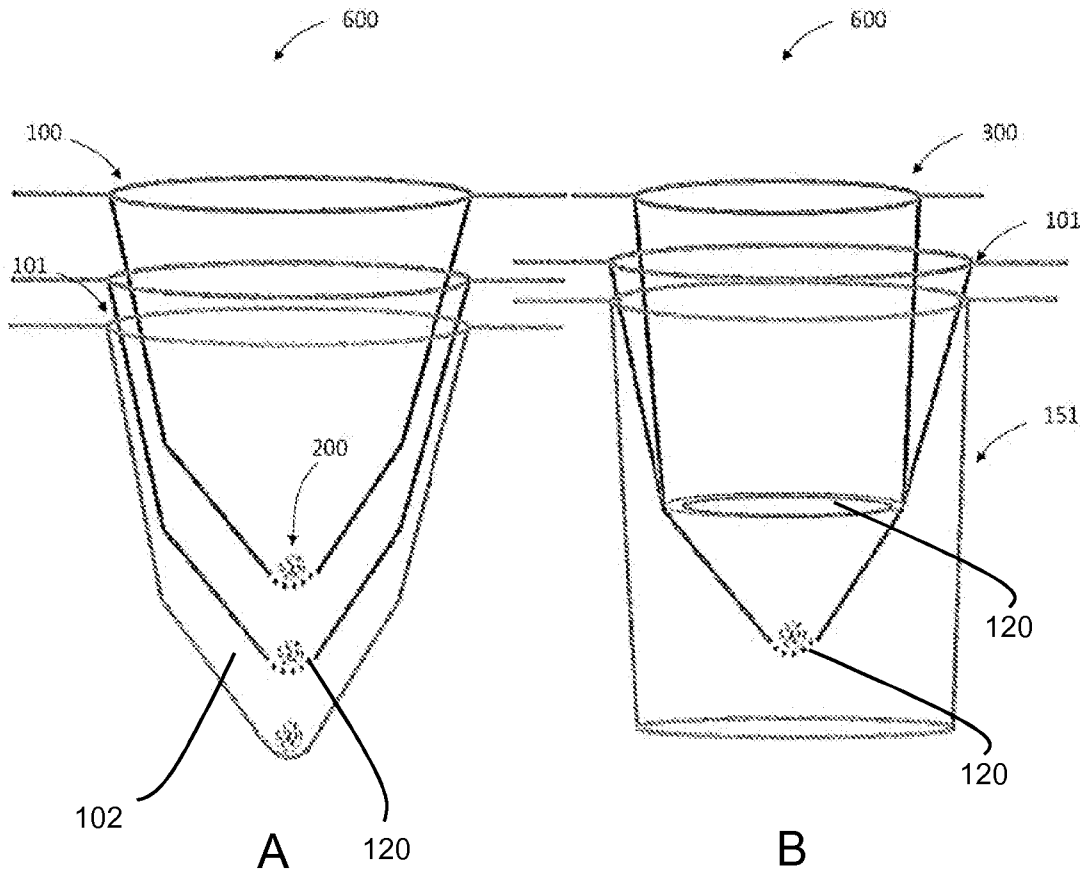

Fig. 4

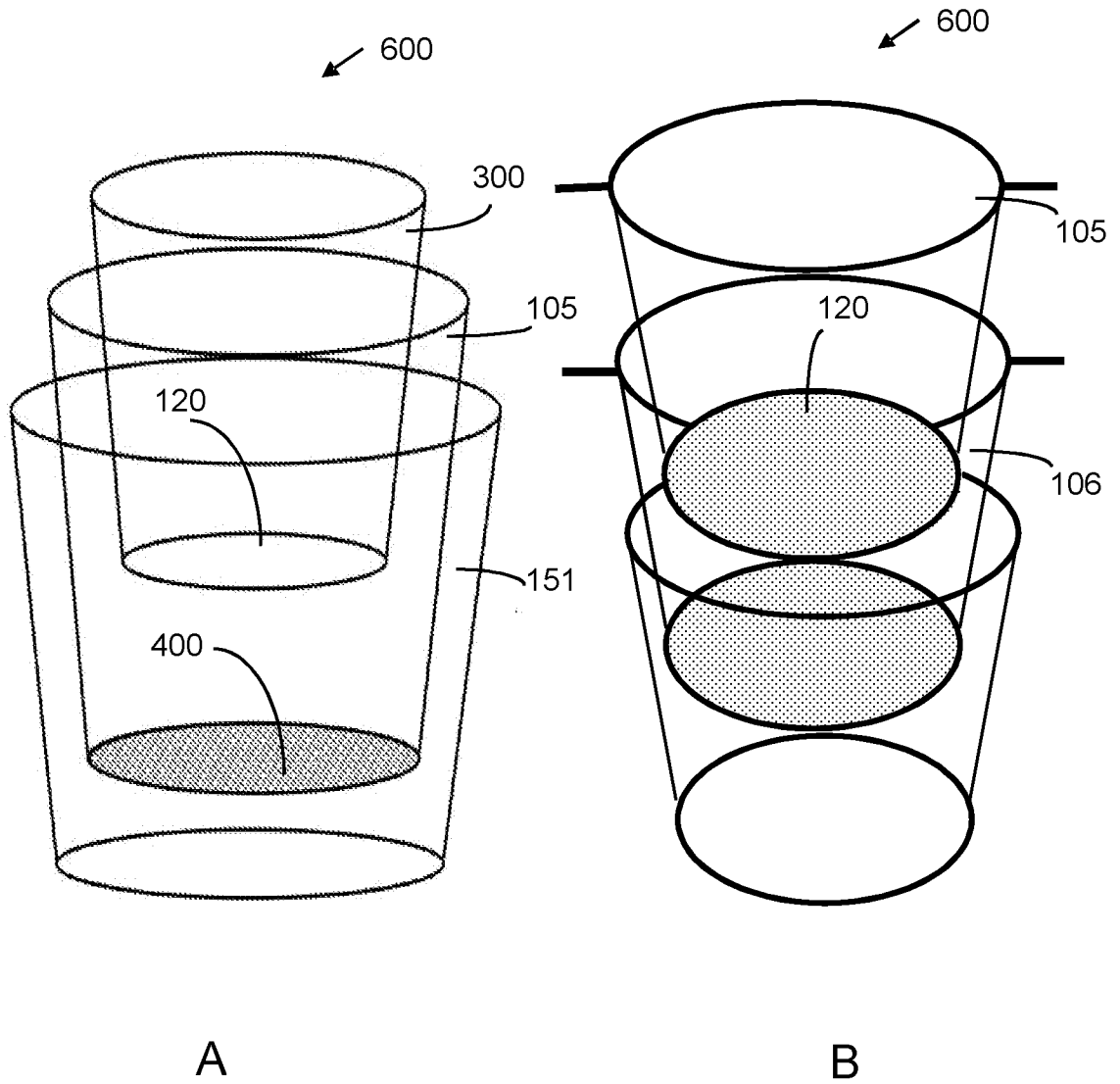

Fig. 5

INTERNATIONAL SEARCH REPORT

International application No
PCT/US2015/058053

A. CLASSIFICATION OF SUBJECT MATTER
INV. C12M1/12 C12M3/00
ADD.
According to International Patent Classification (IPC) or to both national classification and IPC

B. FIELDS SEARCHED
Minimum documentation searched (classification system followed by classification symbols)
C12M
Documentation searched other than minimum documentation to the extent that such documents are included in the fields searched

Electronic data base consulted during the international search (name of data base and, where practicable, search terms used)
EPO-Internal, WPI Data, BIOSIS

C. DOCUMENTS CONSIDERED TO BE RELEVANT		
Category*	Citation of document, with indication, where appropriate, of the relevant passages	Relevant to claim No.
X	WO 92/07063 A2 (COSTAR CORP [US]) 30 April 1992 (1992-04-30)	1,8,11, 12
Y	figures 1,2 bottom page 13 claims 1, 4	2,3,5-7, 9,10, 13-20
A	-----	4,21-41
Y	WO 2014/165273 A1 (INNOVATIVE SURFACE TECHNOLOGIES INC [US]) 9 October 2014 (2014-10-09) Top page 9 Top page 17	2,3,5-7, 9,10
Y	US 2010/190197 A1 (MARTIN GREGORY R [US] ET AL) 29 July 2010 (2010-07-29) cited in the application claim 1; figure 1 -----	13-20
	-/--	

Further documents are listed in the continuation of Box C.

See patent family annex.

* Special categories of cited documents :

<p>"A" document defining the general state of the art which is not considered to be of particular relevance</p> <p>"E" earlier application or patent but published on or after the international filing date</p> <p>"L" document which may throw doubts on priority claim(s) or which is cited to establish the publication date of another citation or other special reason (as specified)</p> <p>"O" document referring to an oral disclosure, use, exhibition or other means</p> <p>"P" document published prior to the international filing date but later than the priority date claimed</p>	<p>"T" later document published after the international filing date or priority date and not in conflict with the application but cited to understand the principle or theory underlying the invention</p> <p>"X" document of particular relevance; the claimed invention cannot be considered novel or cannot be considered to involve an inventive step when the document is taken alone</p> <p>"Y" document of particular relevance; the claimed invention cannot be considered to involve an inventive step when the document is combined with one or more other such documents, such combination being obvious to a person skilled in the art</p> <p>"&" document member of the same patent family</p>
---	---

Date of the actual completion of the international search 12 January 2016	Date of mailing of the international search report 20/01/2016
--	--

Name and mailing address of the ISA/ European Patent Office, P.B. 5818 Patentlaan 2 NL - 2280 HV Rijswijk Tel. (+31-70) 340-2040, Fax: (+31-70) 340-3016	Authorized officer Jones, Laura
--	--

INTERNATIONAL SEARCH REPORT

International application No
PCT/US2015/058053

C(Continuation). DOCUMENTS CONSIDERED TO BE RELEVANT		
Category*	Citation of document, with indication, where appropriate, of the relevant passages	Relevant to claim No.
A	US 2014/106394 A1 (KO EUN [KR] ET AL) 17 April 2014 (2014-04-17) figures 1-3 -----	1-41

INTERNATIONAL SEARCH REPORT

Information on patent family members

International application No

PCT/US2015/058053

Patent document cited in search report	Publication date	Patent family member(s)	Publication date	
WO 9207063	A2	30-04-1992	DE 69126882 D1	21-08-1997
			DE 69126882 T2	20-11-1997
			EP 0552308 A1	28-07-1993
			JP 3081241 B2	28-08-2000
			JP H06501619 A	24-02-1994
			US 5272083 A	21-12-1993
			WO 9207063 A2	30-04-1992

WO 2014165273	A1	09-10-2014	NONE	

US 2010190197	A1	29-07-2010	NONE	

US 2014106394	A1	17-04-2014	KR 20140048733 A	24-04-2014
			US 2014106394 A1	17-04-2014
