



(43) International Publication Date  
28 September 2017 (28.09.2017)

(51) International Patent Classification:

*C08K 5/00* (2006.01)      *C08K 5/3437* (2006.01)  
*C09B 5/60* (2006.01)      *C08L 77/00* (2006.01)  
*F21S 8/10* (2006.01)      *C08L 67/00* (2006.01)  
*C08K 5/08* (2006.01)

(21) International Application Number:

PCT/US2017/023141

(22) International Filing Date:

20 March 2017 (20.03.2017)

(25) Filing Language:

English

(26) Publication Language:

English

(30) Priority Data:

62/311,531      22 March 2016 (22.03.2016)      US

(71) Applicant: **E. I. DU PONT DE NEMOURS AND COMPANY** [US/US]; Chestnut Run Plaza, 974 Centre Road, P. O. Box 2915, Wilmington, Delaware 19805 (US).

(72) Inventor: **SUMI, Hiroyuki**; 5-23-10 Gion, Minami-kawachi-cho, Kawachi-gun, Tochigi-Ken, Tochigi 329-0434 (JP).

(74) Agent: **HAINES, Warren M.**; E. I. du Pont de Nemours and Company, Legal Patent Records Center, Chestnut Run Plaza 721/2340, 974 Centre Road, P.O. Box 2915 Wilmington, Delaware 19805 (US).

(81) Designated States (unless otherwise indicated, for every kind of national protection available): AE, AG, AL, AM, AO, AT, AU, AZ, BA, BB, BG, BH, BN, BR, BW, BY, BZ, CA, CH, CL, CN, CO, CR, CU, CZ, DE, DJ, DK, DM, DO, DZ, EC, EE, EG, ES, FI, GB, GD, GE, GH, GM, GT, HN, HR, HU, ID, IL, IN, IR, IS, JP, KE, KG, KH, KN, KP, KR, KW, KZ, LA, LC, LK, LR, LS, LU, LY, MA, MD, ME, MG, MK, MN, MW, MX, MY, MZ, NA, NG, NI, NO, NZ, OM, PA, PE, PG, PH, PL, PT, QA, RO, RS, RU, RW, SA, SC, SD, SE, SG, SK, SL, SM, ST, SV, SY, TH, TJ, TM, TN, TR, TT, TZ, UA, UG, US, UZ, VC, VN, ZA, ZM, ZW.

(84) Designated States (unless otherwise indicated, for every kind of regional protection available): ARIPO (BW, GH, GM, KE, LR, LS, MW, MZ, NA, RW, SD, SL, ST, SZ, TZ, UG, ZM, ZW), Eurasian (AM, AZ, BY, KG, KZ, RU, TJ, TM), European (AL, AT, BE, BG, CH, CY, CZ, DE, DK, EE, ES, FI, FR, GB, GR, HR, HU, IE, IS, IT, LT, LU, LV, MC, MK, MT, NL, NO, PL, PT, RO, RS, SE, SI, SK, SM, TR), OAPI (BF, BJ, CF, CG, CI, CM, GA, GN, GQ, GW, KM, ML, MR, NE, SN, TD, TG).

Published:

— with international search report (Art. 21(3))

(54) Title: VEHICLE HEADLIGHT ASSEMBLY

FIG. 1

100

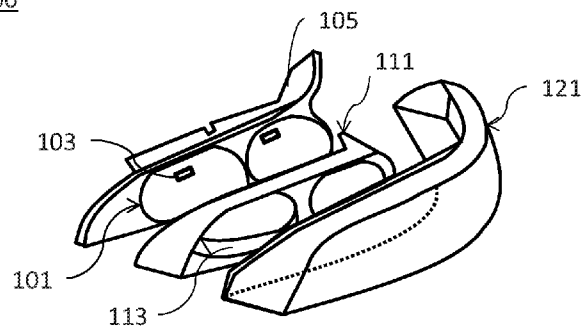

(57) Abstract: This invention relates to a vehicle headlight assembly comprising: a light source, a housing supporting the light, a bezel equipped over the front side of the housing, and a transparent cover being equipped over the front side of the bezel, wherein the bezel and optionally the housing comprises a thermoplastic resin and a colorant, wherein the colorant is selected from the group consisting of an anthraquinone dye, an amine salt thereof and a mixture thereof.



**TITLE****VEHICLE HEADLIGHT ASSEMBLY****CROSS-REFERENCE TO RELATED APPLICATION**

5           This application claims the benefit of U.S. Provisional Application No.62/311531, filed March 22, 2016. Which is incorporated by reference herein in its entirety.

**FIELD OF THE INVENTION**

10           The invention relates to a vehicle, more specifically to a vehicle headlight assembly used thereof.

**TECHNICAL BACKGROUND OF THE INVENTION**

15           A vehicle headlight assembly contains a light, a housing, a bezel and a cover. Usually a bezel is metal color to reflect light from a light source and sunlight. The other colors of vehicle headlight are required for a variety of designs.

20           US2010227183 discloses an automotive headlight extensions, bezels and reflectors that are made from a composition comprising poly(trimethylene terephthalate), trisodium phosphate, a pentaerythritol tetramontanate mold release lubricant and a carbon black. The surface of the bezel is plated with a metal coating.

**BRIEF SUMMARY OF THE INVENTION**

An objective is to provide a vehicle headlight assembly with sufficient heat resistance.

An aspect of the invention relates to A vehicle headlight assembly comprising: a light source, a housing supporting the light, a bezel equipped over the front side of the housing, and a transparent cover being equipped over the front side of the bezel, wherein the bezel and optionally the housing comprises a thermoplastic resin and a colorant, wherein the colorant is selected from the group consisting of an anthraquinone dye, an amine salt thereof and a mixture thereof.

Another aspect of the invention relates to a vehicle bezel comprising a thermoplastic resin and a colorant, wherein the colorant is selected from the group consisting of an anthraquinone dye, an amine salt thereof and a mixture thereof.

Another aspect of the invention relates to a method of manufacturing a vehicle headlight assembly comprising steps of:

preparing a thermoplastic resin composition comprising a thermoplastic resin and a colorant, wherein the colorant is selected from the group consisting of an anthraquinone dye, an amine salt thereof and a mixture thereof;

forming a bezel by injection molding the resin composition;

equipping the bezel on the front side of a housing holding a light; and

equipping a transparent cover on the front side of the bezel.

A vehicle headlight assembly with heat resistance can be provided by the present invention.

## BRIEF DESCRIPTION OF THE DRAWINGS

FIG. 1 depicts one embodiment of a vehicle headlight assembly.

## DETAILED DESCRIPTION OF THE INVENTION

5           The vehicle headlight assembly comprises a light, a housing, a bezel and a transparent cover. FIG. 1 illustrates one example of the vehicle headlight assembly 100. The housing 105 holds a light 101. The light 101 contains at least one light source 103. The bezel 111 is equipped on the front side of the housing 105. "Front side" is a side facing toward the front of the vehicle. The bezel 111 has holes 113 that the lights 101 fit in. The transparent cover 121 is  
10 equipped on the front side of the bezel 111 to cover the lights 113. The bezel 111 and optionally the housing 105 are colored in dark color in an embodiment, dark blue in another embodiment, dark green in another embodiment, dark violet in another embodiment, black in another embodiment. The bezel 111 and  
15 optionally the housing 105 are not plated with a metal in another embodiment.

The bezel 111 and optionally the housing 105 comprise a thermoplastic resin and a colorant, wherein the colorant is selected from the group consisting of an anthraquinone dye, an amine salt thereof and a mixture thereof.

The bezel 111 and optionally the housing 105 are formed by injection  
20 molding a resin composition in an embodiment. The resin composition comprises the thermoplastic resin and the colorant.

### Thermoplastic Resin

There is no restriction on the thermoplastic resin. A wide range of thermoplastic resin useful for molding is available. The black colorant is

dispersed into the thermoplastic resin to form a resin composition.

The thermoplastic resin can comprise polyamide, polyester, polyphenylene sulfide, polyacetal, polycarbonate, polysulfone, polyethylene, polyether sulfone, methacrylate, polyamide-imide, fluoroplastic and a mixture thereof in an embodiment. The thermoplastic resin can comprise polyamide, polyester and a mixture thereof in another embodiment. The thermoplastic resin can comprise polyester in another embodiment.

The polyamide resin can comprise a condensation product of dicarboxylic acids and diamines, a condensation product of aminocarboxylic acids and ring-opening polymerization products of cyclic lactams in an embodiment.

The dicarboxylic acids of polyamide can be adipic acid, azelaic acid, sebacic acid, dodecanedioic acid, isophthalic acid and terephthalic acid in an embodiment. The diamine can be tetramethylene diamine, hexamethylene diamine, octamethylene diamine, nonamethylene diamine, dodecamethylene diamine, 2-methylpentamethylene diamine, 2-methyloctamethylene diamine, trimethylhexamethylene diamine, bis(p-aminocyclohexyl)methane, m-xylene diamine and p-xylene diamine in an embodiment. The aminocarboxylic acid can be 11-aminododecanoic acid in an embodiment. The cyclic lactam can be caprolactam or lauro lactam in an embodiment.

The condensation products and ring-opening polymerization products can be aliphatic polyamide, semi-aromatic polyamide, copolymer thereof or a mixture thereof in another embodiment. The thermoplastic resin can comprise nylon 6, nylon 66, nylon 46, nylon 610, nylon 612, nylon 11, and nylon 12,

polymetaxylene adipamide (nylon MXD6), polyhexamethylene terephthalamide (nylon 6T), polyhexamethylene isophthalamide (nylon 6I) a polynonamethylene terephthalamide (nylon 9T), nylon 6/66, nylon 66/6I, nylon 6I/6T, nylon 66/6T or a mixture thereof in another embodiment.

5           The thermoplastic resin can comprise polyester in another embodiment. The polyester is condensation products of dicarboxylic acids and diols. Dicarboxylic acids of polyester can be selected from the group consisting of adipic acid, azelaic acid, sebacic acid, dodecanedioic acid, terephthalic acid, isophthalic acid, naphthalenedicarboxylic acid and diphenyl dicarboxylic acid in  
10 an embodiment. Diols can be selected from the group consisting of ethylene glycol, propylene glycol, butanediol, hexanediol, neopentyl glycol, cyclohexanediol, and bisphenol A in an embodiment.

          The polyester can be selected from the group consisting of polyethylene terephthalate (PET), polybutylene terephthalate (PBT), Polytrimethylene  
15 terephthalate (PTT), polyethylene 2,6-naphthalate (PEN), polybutylene naphthalate (PBN), polycyclohexane dimethylene terephthalate (PCT), a copolymer thereof and a mixture thereof in an embodiment. As the examples of the copolymers, some of dicarboxylic acids or some of diols can be added to the condensation products. Polyester may be copolymerized a little amount of  
20 components like trimesic acid, trimellitic acid, pyromellitic acid, glycerol, and pentaerythritol which have more than three functional groups in another embodiment.

### **Colorant**

          The colorant is selected from the group consisting of an anthraquinone

dye, an amine salt thereof and a mixture thereof. Anthraquinone is an aromatic organic compound with formula  $C_{14}H_8O_2$ . The anthraquinone dye is anthraquinone or a derivative of anthraquinone.

The anthraquinone dye absorbs the visible light region at less than 700  
5 nm and transmits the light of infra-red region at 800 to 1200 nm in an embodiment.

The anthraquinone dye can be selected from the group consisting of an anthraquinone green dye, an anthraquinone blue dye, an anthraquinone violet dye, an anthraquinone red dye, an anthraquinone orange dye, an anthraquinone  
10 yellow dye and a mixture thereof in another embodiment. The anthraquinone dye can be selected from the group consisting of an anthraquinone green dye, an anthraquinone blue dye, an anthraquinone violet dye, an anthraquinone yellow dye and a mixture thereof in another embodiment.

The anthraquinone green dye can be selected from the group consisting  
15 of C.I. Solvent Green 3, 5, 6, 7, 19, 20, 22, 23, 24, 25, 26, 28, 29 and a mixture thereof in another embodiment.

The anthraquinone blue dye can be selected from the group consisting of C.I. Solvent Blue 11, 12, 13, 14, 16, 17, 18, 19, 20, 21, 35, 36, 40, 41, 45, 58, 59, 63, 65, 68, 69, 74, 76, 78, 79, 80, 82, 83, 84, 85, 86, 87, 90, 91, 92, 93, 94,  
20 95, 96, 97, 98, 101, 102, 103, 104, 105, 106, 107, 108, 109, 110, 111, 112, 113, 114, 116, 119, 120, 121, 122, 123, 126, 128, 130, 132, 134, 136, 139, C.I. Vat Blue 4, 6, 11, 12, 13, 14 and a mixture thereof in another embodiment.

The anthraquinone violet dye can be selected from the group consisting of C.I. Solvent Violet 11, 12, 13, 14, 15, 26, 28, 30, 31, 33, 34, 36, 37, 38, 40, 41,

42 and a mixture thereof in another embodiment.

The anthraquinone red dye can be selected from the group consisting of C.I. Solvent Red 52, 57, 111, 114, 136, 137, 138, 139, 143, 144, 145, 146, 147, 148, 149, 150, 151, 152, 155, 156, 168, 169, 170, 171, 172, 177, 181, 190, 191,  
5 194, 199, 200, 201 and a mixture thereof in another embodiment.

The anthraquinone orange dye can be selected from the group consisting of C.I. Solvent Orange 35, 55, 64, 65, 66, 68, 69, 71, 77, 86, 87, 163 and a mixture thereof in another embodiment.

The anthraquinone yellow dye can be selected from the group consisting  
10 of C.I. Solvent Yellow 100, 109, 117, 125, 156, 158, 163 or C.I. Vat Yellow 1, 2, 3 and a mixture thereof in another embodiment.

The anthraquinone dye can be represented by the following formula [I], formula [II-a] or formula [II-b] in another embodiment.

Formula [I]

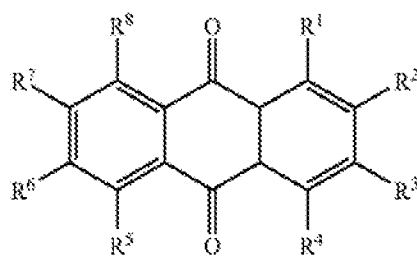

15

wherein R<sup>1</sup> to R<sup>8</sup> is independently H, OH, NH<sub>2</sub>, OCH<sub>3</sub>, CH<sub>3</sub>NH, C<sub>4</sub>H<sub>9</sub>NH, C<sub>5</sub>H<sub>11</sub>NH, Br, NOC<sub>2</sub>H<sub>4</sub>NH, methylanilino, aniline, benzoylamido, ethylanilino, cyclohexyl amido or phenyloxy.

Formula [II-a]



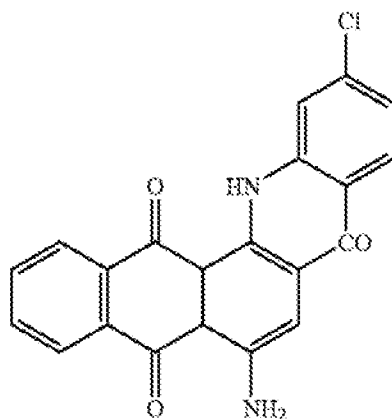

Formula [II-b]

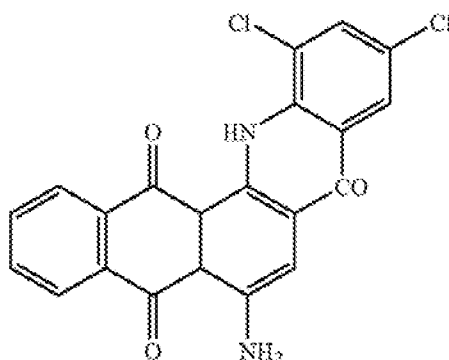

5 Examples of anthraquinone dye of formula [I] are shown below.

Table 1

$R^1, R^2, R^3, R^4, R^5, R^6, R^7, R^8$
$R^2=R^3=R^4=R^5=R^6=R^7=R^8=H, R^1=\text{methylanilino}$
$R^2=R^3=R^5=R^6=R^7=R^8=H, R^4=OH, R^1=\text{methylanilino}$
$R^2=R^3=R^5=R^6=R^7=R^8=H, R^4=NH_2, R^1=\text{anilino}$
$R^2=R^3=R^5=R^6=R^7=R^8=H, R^4=OCH_3, R^1=\text{benzoylamido}$
$R^2=R^3=R^5=R^6=R^7=R^8=H, R^1=R^4=NH_2$
$R^2=R^3=R^5=R^6=R^7=R^8=H, R^4=NH_2, R^1=\text{cyclohexyl amido}$
$R^2=R^3=R^5=R^6=R^7=R^8=H, R^4=NH_2, R^1=CH_3NH$
$R^2=R^3=R^5=R^6=R^7=R^8=H, R^1=R^4=C_4H_9NH$

An amine salt of an anthraquinone dye can also be used as a colorant.

The colorant can comprise a mixture of an anthraquinone dye and an amine salt of an anthraquinone dye in another embodiment. The colorant can comprise amine salt of an anthraquinone dye without an anthraquinone dye in another embodiment. The amine salt of an anthraquinone dye comprises

5 anthraquinone or an anthraquinone derivative and amine salt. The amine salt is a salt formed from amino compound and acid. The amine salt of an anthraquinone dye has transmittance at a wavelength of 800 nm to 1200 nm in an embodiment.

The amine salt of an anthraquinone dye can be represented by the

10 following formula [III] or formula [IV] in another embodiment.

Formula [III]

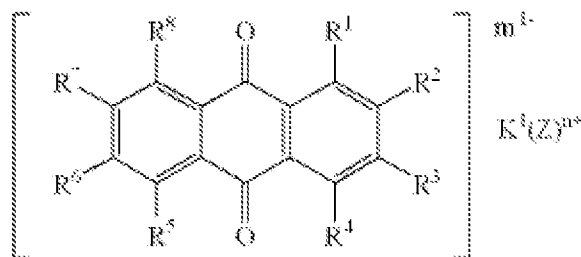

wherein R<sup>1</sup> to R<sup>8</sup>, which may be the same or different, are independently selected from the group consisting of H, alkyl, aryl, alkenyl, alkoxy, amino,

15 hydroxy, halogen atom, acyl, acyloxy, acylamide, acyl-N-alkylamide, carboxyl, alkoxy carbonyl, cyclohexylamide, sulfonyl, formula [1-a], or-Y-W, and at least

one of R<sup>1</sup> to R<sup>8</sup> is of formula [III-a]; wherein Y is S, O, or NH; wherein W is selected from unsubstituted or substituted alkyl group, alkenyl group, and

unsubstituted or substituted aryl group; wherein (Z)<sup>n+</sup> represents ammonium ion

20 or a cation derived from an organic amine compounds or a basic dye; wherein n

is 1 or 2, m is an integer from 1 to 4 and K<sub>1</sub> is the ratio of m/n; and wherein

formula [III-a] is:

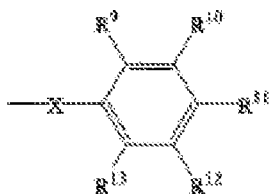

wherein X is O or NH, and R<sup>9</sup> to R<sup>13</sup>, which may be the same or different, are independently selected from the group consisting of H, alkyl, aryl, alkenyl, alkoxy, amino, N-alkylamide, N-arylamide, hydroxy, halogen atom, acyl, acyloxy, acylamide, acyl-N-alkylamide, carboxyl, alkoxy-carbonyl, or sulfonyl; wherein at least one of R<sup>1</sup> to R<sup>8</sup> and R<sup>9</sup> to R<sup>13</sup> is sulfonyl group.

Formula [IV]

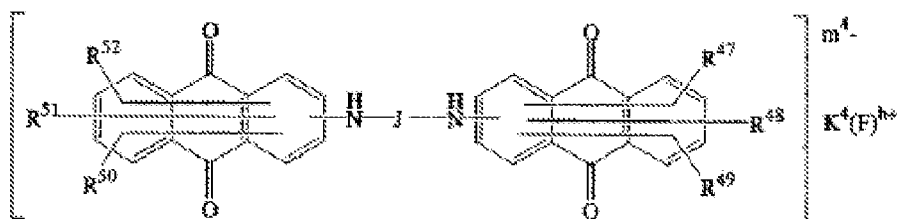

wherein R<sup>47</sup> to R<sup>52</sup>, which may be the same or different, are independently selected from the group consisting of H, alkyl, aryl, alkenyl, alkoxy, amino, N-alkylamide, N-arylamide, hydroxy, halogen atom, acyl, acyloxy, acylamide, acyl-N-alkylamide, carboxyl, alkoxy-carbonyl, or sulfonyl, and at least one of R<sup>47</sup> to R<sup>52</sup> is of sulfonyl; (F)<sup>h+</sup> represents ammonium ion or a cation derived from an organic amino compounds or a basic dye wherein h is 1 or 2, m<sup>4</sup> is an integer from 1 to 4 and K<sup>4</sup> is the ratio of m<sup>4</sup>/h; J is following formula [IV-a] or formula [IV-b].

Formula [IV-a]

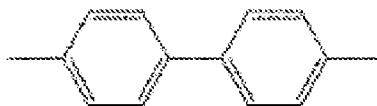

Formula [IV-b]

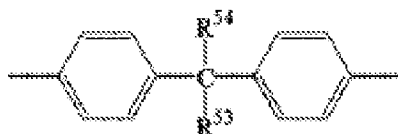

wherein  $R^{53}$  to  $R^{54}$ , which may be the same or different, are independently  
 5 selected from the group consisting of alkyl (having 1 to 8 carbon atoms) or  
 hydrogen.

Amine of the amine salt can be selected from the group consisting of  
 aliphatic amine, alicyclic amine, alkoxyalkyl amine, amine having alkanol,  
 diamine, amine of guanidine derivatives and aromatic amine in another  
 10 embodiment.

The amine salt of an anthraquinone dye, as listed in the color index, can  
 be selected from the group consisting of C.I. basic green dye, C.I. basic blue dye,  
 C.I. basic violet dye, C. I. basic red dye and a mixture thereof in another  
 embodiment.

15 C.I. basic green dye can be selected from the group consisting of C.I.  
 basic green 1, 3, 4, 6, 9, 10 and a mixture thereof in an embodiment.

C.I. basic blue dye: C.I. basic blue 1, 2, 3, 4, 5, 6, 7, 8, 9, 10, 11, 12, 13,  
 14, 15, 18, 20, 21, 22, 23, 24, 25, 26, 35, 36, 37, 45, 46, 47, 49, 50, 55, 56, 60,  
 62, 67, 75, 77, 79, 80, 81, 83, 87, 88, 89, 90, 94, 95, 96, 97 and a mixture thereof  
 20 in an embodiment.

C.I. basic violet dye: C.I. basic violet 1, 2, 3, 4, 5, 6, 7, 8, 10, 11, 12, 13,

14, 15, 16, 17, 20, 21, 23, 24, 25, 27, 40 and a mixture thereof in an embodiment.

C.I. basic red dye: C.I. basic red 1, 2, 3, 4, 5, 6, 8, 9, 10, 11, 12, 13, 15, 16, 17, 19, 20, 26, 27, 35, 36, 37, 48, 49, 52, 53, 54, 66, 68 and a mixture thereof

5 in an embodiment.

Examples of the amine salt anthraquinone dye of formula [III] are given below in Table 2.

Table 2

$R^1, R^2, R^3, R^4, R^5, R^6, R^7, R^8$	$K^1(Z)^{n+}$
$R^2=R^5=R^6=R^7=R^8=H, R^4=OH, R^1=R^3=$ Formula [III-a]: $X=NH, R^{11}=NO_2, R^9=SO_3^-, R^{10}=R^{12}=R^{13}=H$	Rosin ammonium
$R^2=R^3=R^5=R^6=R^7=R^8=H, R^4=OH, R^1=$ Formula [III-a]: $X=NH, R^{11}=CH_3, R^9=SO_3^-, R^{10}=R^{12}=R^{13}=H$	$H_3N+((CH_2)_6NH$
$R^2=R^3=R^5=R^6=R^7=R^8=H, R^1=$ Formula [III-a], $R^4=Y-W: X=NH, R^{11}=CH_3, R^9=SO_3^-, R^{10}=R^{12}=R^{13}=H, Y=NH, W=CH_3$	$C_{12}H_{25}N+H_3$
$R^2=R^3=R^5=R^6=R^7=R^8=H, R^1=R^4=$ Formula [III-a]: $X=NH, R^{11}=CH_3, R^9=SO_3H, R^{10}=R^{12}=R^{13}=H$	$(C_4H_9)_4N+$
$R^2=R^3=R^5=R^6=R^7=R^8=H, R^1=R^4=$ Formula [III-a]: $X=NH, R^9=R^{11}=R^{13}=CH_3, R^{12}=SO_3H, R^{10}=H$	$H_3N+((CH_2)_6NH_2$
$R^2=R^3=R^5=R^6=R^7=R^8=H, R^1=R^4=$ Formula [III-a]: $X=NH, R^{11}=CH_3, R^9=SO_3^-, R^{10}=R^{12}=R^{13}=H$	$(N+H_3)_2CNH$
$R^2=R^3=R^5=R^6=R^7=R^8=H, R^1=R^4=$ Formula [III-a]: $X=NH, R^{11}=C_4H_9, R^9=SO_3H, R^{10}=R^{12}=R^{13}=H$	$H_3N+(CH_2)_6NH_2$

10 Examples of the amine salt anthraquinone dye of formula [IV] are given in Table 3 below.

Table 3

J	R <sup>47</sup>	R <sup>48</sup>	R <sup>49</sup>	R <sup>50</sup>	R <sup>51</sup>	R <sup>52</sup>	K <sup>4</sup> (F) <sup>h+</sup>
Formula [IV-a]	SO <sub>3</sub> <sup>-</sup>	NH <sub>2</sub>	H	SO <sub>3</sub> <sup>-</sup>	NH <sub>2</sub>	H	2(H <sub>3</sub> N <sup>+</sup> (CH <sub>2</sub> ) <sub>6</sub> NH <sub>2</sub> )
Formula [IV-a]	SO <sub>3</sub> <sup>-</sup>	NH <sub>2</sub>	H	SO <sub>3</sub> H	NH <sub>2</sub>	H	H <sub>3</sub> N <sup>+</sup> (CH <sub>2</sub> ) <sub>6</sub> NH <sub>2</sub>
Formula [IV-a]	SO <sub>3</sub> <sup>-</sup>	OH	H	SO <sub>3</sub> H	OH	H	C <sub>12</sub> H <sub>25</sub> N <sup>+</sup> H <sub>3</sub>
Formula [IV-b], R <sup>53</sup> =R <sup>54</sup> =H	SO <sub>3</sub> <sup>-</sup>	NH <sub>2</sub>	H	NH <sub>2</sub>	Cl	H	C <sub>2</sub> H <sub>5</sub> OC <sub>3</sub> H <sub>6</sub> N <sup>+</sup> H <sub>3</sub>
Formula [IV-b], R <sup>53</sup> =R <sup>54</sup> =CH <sub>3</sub>	SO <sub>3</sub> <sup>-</sup>	NH <sub>2</sub>	H	SO <sub>3</sub> <sup>-</sup>	NH <sub>2</sub>	H	H <sub>3</sub> N <sup>+</sup> (CH <sub>2</sub> ) <sub>4</sub> N <sup>+</sup> H <sub>3</sub>
Formula [IV-b], R <sup>53</sup> =R <sup>54</sup> =CH <sub>3</sub>	SO <sub>3</sub> <sup>-</sup>	NH <sub>2</sub>	H	SO <sub>3</sub> H	NH <sub>2</sub>	H	Rosin ammonium
Formula [IV-b], R <sup>53</sup> =R <sup>54</sup> =H	SO <sub>3</sub> <sup>-</sup>	NH <sub>2</sub>	H	SO <sub>3</sub> H	NH <sub>2</sub>	H	H <sub>3</sub> N <sup>+</sup> (CH <sub>2</sub> ) <sub>6</sub> NH <sub>2</sub>
Formula [IV-b], R <sup>53</sup> =H,R <sup>54</sup> =phenyl	SO <sub>3</sub> <sup>-</sup>	OH	OCH <sub>3</sub>	SO <sub>3</sub> H	OH	OCH <sub>3</sub>	(C <sub>4</sub> H <sub>9</sub> ) <sub>4</sub> N <sup>+</sup>

The colorant can be 0.01 to 12 parts by weight in an embodiment. The colorant can be 9 parts by weight or less in another embodiment, 6 parts by weight or less in another embodiment, 4 parts by weight or less in another embodiment, 1.5 parts by weight or less in another embodiment, 1.0 parts by weight or less, 0.5 parts by weight or less in another embodiment, 0.3 parts by weight or less in another embodiment, as the thermoplastic resin is 100 parts by weight. The colorant can be 0.05 parts by weight or more in another embodiment, 0.1 parts by weight or more in another embodiment, 0.15 parts by weight or more in another embodiment as the thermoplastic resin is 100 parts by weight.

**Additional Colorant**

The bezel and optionally the housing can comprise an additional colorant in another embodiment. The additional colorant can be selected from the group consisting of a perinone dye, an azo dye and a mixture thereof in an embodiment. The additional dye can be used in addition to the anthraquinone

dye and/or the amine salt of an anthraquinone dye to adjust the color in another embodiment. The perinone dye and the azo dye could transmit the light of infra-red region at 800 to 1200 nm in an embodiment.

The perinone dye can comprise a chemical structure of formula [V] in an  
5 embodiment.

Formula [V]

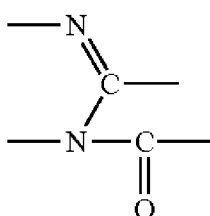

The perinone dye can be represented by formula [VI] in another  
embodiment.

10

Formula [VI]

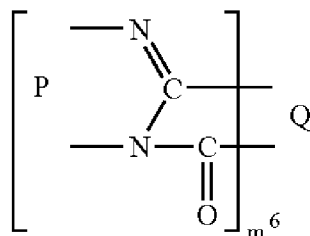

wherein P and Q, which may be the same or different, are independently  
constituent units which can be represented by the following formula [VI-a], [VI-b]  
15 or [IV-c].

Formula [VI-a]:

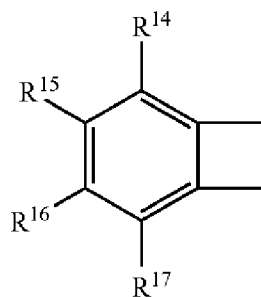

Formula [VI-b]:

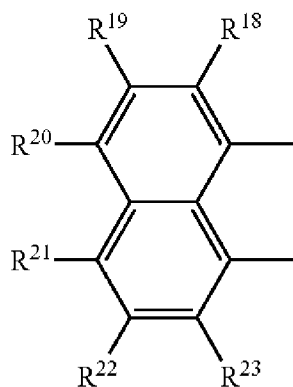

5

Formula [VI-c]:

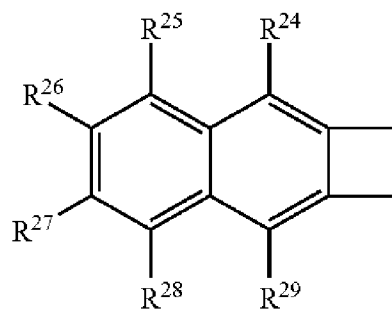

wherein R<sup>14</sup> to R<sup>29</sup>, which may be the same or different, are independently an  
 10 atom or a group selected from the group consisting of H, halogen atom such as  
 Cl, Br, alkyl group having 1 to 18 carbon atoms, alkoxy group having 1 to 18  
 carbon atoms, aralkyl group and aryl group; and m<sup>6</sup> is 1 or 2.



The perinone dye can be selected from the group consisting of C.I. Solvent Orange 60, 78, C.I. Solvent Red 135, 162, 178, 179, C.I. Violet 29, C.I. Pigment Orange 43, C.I. Pigment Red 149 and a mixture thereof in another embodiment.

5           Examples of the perinone dye of formula [VI] are illustrated in Table 4 below.

Table 4

P	Q
Formula [VI-b]: $R^{18}=R^{19}=R^{20}=R^{21}=R^{22}=R^{23}=H$	Formula [VI-a]: $R^{14}=R^{15}=R^{16}=R^{17}=H$
Formula [VI-b]: $R^{18}=R^{19}=R^{20}=R^{21}=R^{22}=R^{23}=H$	Formula [VI-a]: $R^{14}=R^{15}=R^{16}=R^{17}=Cl$
Formula [VI-b]: $R^{18}=R^{19}=R^{20}=R^{21}=R^{22}=R^{23}=H$	Formula [VI-c]: $R^{24}=R^{25}=R^{26}=R^{27}=R^{28}=R^{29}=H$
Formula [VI-a]: $R^{14}=R^{15}=R^{16}=R^{17}=H$	Formula [VI-b]: $R^{18}=R^{19}=R^{20}=R^{21}=R^{22}=R^{23}=H$
Formula [VI-b]: $R^{18}=R^{19}=R^{20}=R^{21}=R^{22}=R^{23}=H$	Formula [VI-c]: $R^{24}=R^{26}=R^{27}=R^{28}=R^{29}=H$ , $R^{25}=OC_2H_5$
Formula [VI-b]: $R^{18}=R^{19}=R^{20}=R^{21}=R^{22}=R^{23}=H$	Formula [VI-a]: $R^{14}=R^{15}=R^{17}=H$ , $R^{16}=benzoyl$
Formula [VI-b]: $R^{18}=R^{19}=R^{20}=R^{22}=R^{23}=H$ , $R^{21}=C_4H_9$	Formula [VI-a]: $R^{14}=R^{17}=H$
Formula [VI-b]: $R^{18}=R^{19}=R^{20}=R^{21}=R^{22}=R^{23}=H$	Formula [VI-c]: $R^{24}=R^{26}=R^{27}=R^{28}=R^{29}=R^{25}=phenyl$
Formula [VI-b]: $R^{18}=R^{19}=R^{20}=R^{21}=R^{22}=R^{23}=H$	Formula [VI-a]: $R^{15}=R^{16}=R^{17}=H$ , $R^{14}=Br$
Formula [VI-b]: $R^{18}=R^{19}=R^{20}=R^{21}=R^{22}=R^{23}=H$	Formula [VI-a]: $R^{15}=R^{16}=R^{17}=H$ , $R^{14}=COOH$

The azo dye comprises at least one azo group ( $-N=N-$ ). The azo dye can be selected from the group consisting of a monoazo dye, a disazo dye and a mixture thereof in another embodiment.

The azo dye can be selected from the group consisting of C.I. Solvent Yellow 1, 2, 3, 14, 18, 77, 97; C.I. Solvent Red 1, 3, 4, 18, 19, 23, 24, 33; C.I. Solvent Orange 2, 3, 7; C.I. Pigment Red 40, 49, 54; C.I. Pigment Yellow 81, 83 and a mixture thereof.

The azo dye can be represented by formula [VII].

Formula [VII]

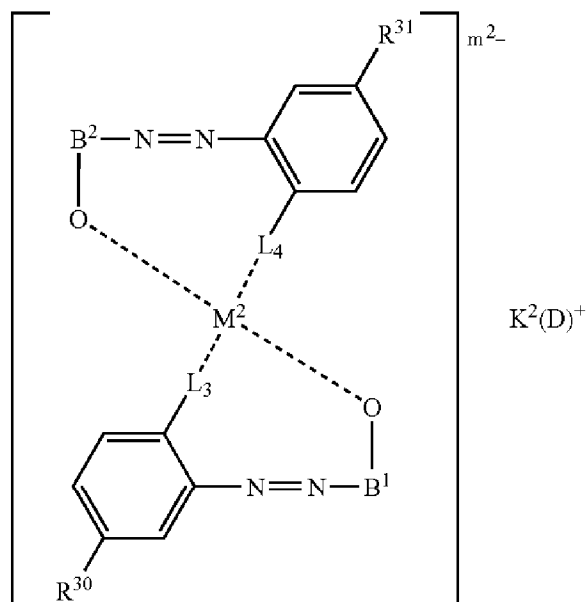

wherein  $R^{30}$  and  $R^{31}$ , which may be the same or different, are Cl,  $SO_2R^{32}$ ,  $SO_2(-R^{33})(-R^{34})$ , or H; wherein  $R^{32}$  is linear or branched C1-C4 alkyl;  $R^{33}$  and  $R^{34}$ ,  
 5 which may be the same or different, are independently hydrogen atom, linear or branched C1-C4 alkyl;  $L_3$  and  $L_4$  are independently O or COO;  $(D)^+$  is hydrogen ion, cation of alkali metals, ammonium ion, cations of organic amine including aliphatic primary, secondary and tertiary amines, quaternary ammonium ion;  $K^2$  is an integer,  $m^2$  is 0, 1 or 2;  $M^2$  is selected from metals of ionic valency from 2 to  
 10 4 (such as Zn, Sr, Cr, Al, Ti, Fe, Zr, Ni, Mn, B and Co), metal of trivalent metal such as Cu or trivalent metal such as Cr, Co, Ni, and Al;  $B^1$  and  $B^2$  are represented by formula [VII-a] or formula [VII-b].

Formula [VII-a]

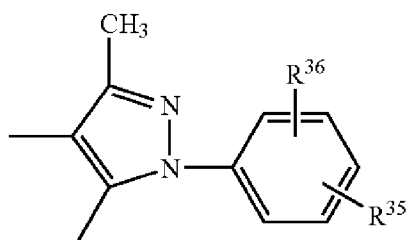

Formula [VII-b]

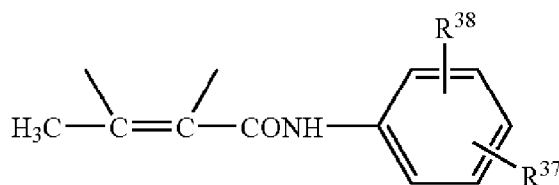

5

wherein  $R^{35}$  and  $R^{37}$ , which may be the same or different, are Cl,  $SO_2R^{32}$ ,  $SO_2(-R^{33})(-R^{34})$  or H;  $R^{33}$  and  $R^{34}$ , which may be the same or different, are independently hydrogen atom, linear or branched C1-C4 alkyl; and  $R^{36}$  and  $R^{38}$ , which may be the same or different, are independently hydrogen atom, linear or branched C1-C18 alkyl, carboxyl, hydroxyl, C1-C18 alkoxy, amino or halogen atoms.

The cations in the above-mentioned azo dye of formula [VII] are  $H^+$ ; cations of alkali metal, ammonium ion, cations of organic amine including aliphatic primary, secondary and tertiary amines, and quaternary ammonium ion.

Suitable amines for use in producing the above-mentioned monoazo complex dyes and common in dyestuffs include aliphatic amines, alicyclic amines, alkoxyalkyl amines, amines having alkanol, diamine, amines of guanidine derivatives, and aromatic amines.

Examples of the azo dye of formula [VIII] wherein  $B^1$  and  $B^2$  are of the

formula [VIII-a] are indicated as below formula [VIII-c].

Formula [VIII-c]

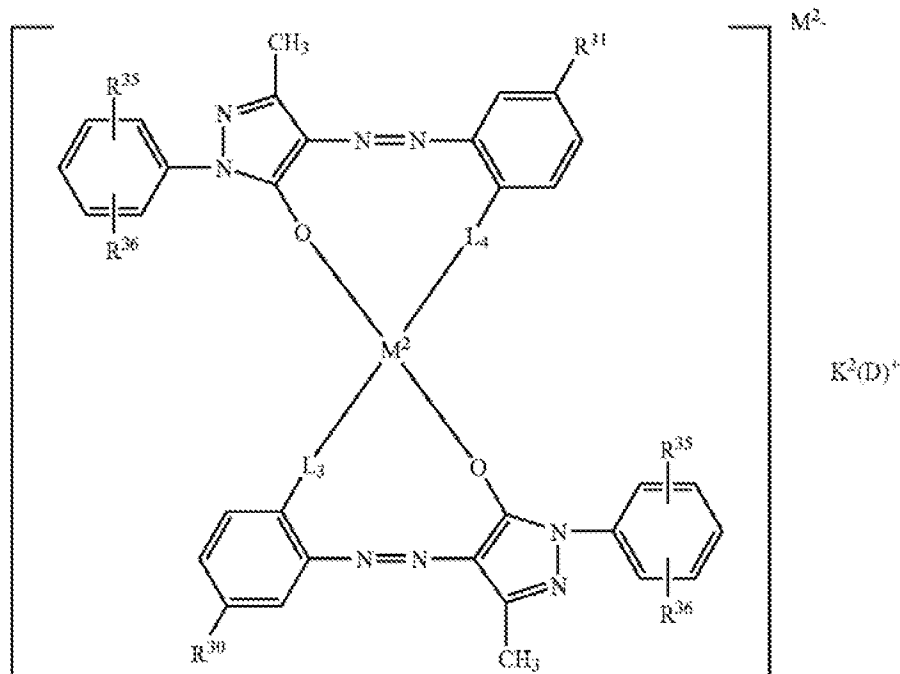

Examples of the azo dye of formula [VIII-c] are illustrated in Table 5.

5 Table 5

R <sup>30</sup>	R <sup>31</sup>	R <sup>35</sup>	R <sup>36</sup>	M <sup>2</sup>	L <sub>3</sub>	L <sub>4</sub>	m <sup>2</sup>	K <sup>2(D)</sup> <sup>+</sup>
H	H	H	H	Cr	COO	COO	1	H <sup>+</sup>
Cl	Cl	SO <sub>2</sub> NH <sub>2</sub>	H	Cr	O	O	1	H <sup>+</sup>
SO <sub>2</sub> NH <sub>2</sub>	SO <sub>2</sub> NH <sub>2</sub>	SO <sub>2</sub> NH <sub>2</sub>	H	Cr	O	O	1	H <sup>+</sup>
Cl	Cl	SO <sub>2</sub> NH <sub>2</sub>	H	Co	O	O	1	H <sup>+</sup>
SO <sub>2</sub> NH <sub>2</sub>	SO <sub>2</sub> NH <sub>2</sub>	H	H	Ni	O	O	1	H <sup>+</sup>
H	H	SO <sub>2</sub> NH <sub>2</sub>	H	Cu	COO	COO	1	H <sup>+</sup>
H	H	H	H	Cr	COO	COO	1	C <sub>4</sub> H <sub>9</sub> CH(C <sub>2</sub> H <sub>5</sub> )OC <sub>3</sub> H <sub>6</sub> N <sup>+</sup> H <sub>3</sub>
Cl	Cl	SO <sub>2</sub> NH <sub>2</sub>	H	Cu	O	O	1	C <sub>12</sub> H <sub>25</sub> N <sup>+</sup> H <sub>2</sub> (CH <sub>2</sub> CH <sub>2</sub> O) <sub>2</sub> H
Cl	Cl	SO <sub>2</sub> NH <sub>2</sub>	H	Cr	O	O	1	Na <sup>+</sup>
Cl	SO <sub>2</sub> NH <sub>2</sub>	H	Cl	Co	O	O	1	H <sup>+</sup>

The additional colorant can be 0.01 to 3 parts by weight in an embodiment. The additional colorant can be 2 parts by weight or less in

another embodiment, 1 parts by weight or less in another embodiment, 0.5 parts by weight or less in another embodiment, 0.1 parts by weight or less in another embodiment, as the thermoplastic resin is 100 parts by weight. The additional colorant can be 0.01 parts by weight or more in another embodiment, 0.02 parts by weight or more in another embodiment as the thermoplastic resin is 100 parts by weight.

There are various examples of combinations of the colorant. For instance, the colorant comprises an anthraquinone dye only in an embodiment, an anthraquinone dye and the additional dye in another embodiment, an anthraquinone blue dye, anthraquinone red dye and anthraquinone yellow dye in another embodiment, an anthraquinone violet dye and anthraquinone yellow dye in another embodiment, an anthraquinone green dye and anthraquinone red dye in another embodiment, an anthraquinone blue dye, anthraquinone red dye and anthraquinone yellow dye in another embodiment, an anthraquinone green dye, anthraquinone red dye and anthraquinone yellow dye in another embodiment, an anthraquinone blue dye, a perinone red dye and anthraquinone yellow dye in another embodiment, an anthraquinone green dye, a perinone red dye, and anthraquinone yellow dye in another embodiment, an anthraquinone green dye and an azo red dye in another embodiment.

The total amount of the colorant and the additional colorant can be 0.02 to 15 parts by weight in an embodiment. The colorant can be 11 parts by weight or less in another embodiment, 7 parts by weight or less in another embodiment, 4 parts by weight or less in another embodiment, 1.5 parts by weight or less in another embodiment, 0.5 parts by weight or less in another

embodiment as the thermoplastic resin is 100 parts by weight. The black colorant can be 0.07 parts by weight or more in another embodiment, 0.09 parts by weight or more in another embodiment, 0.1 parts by weight or more in another embodiment, 0.15 parts by weight or more in another embodiment as  
5 the thermoplastic resin is 100 parts by weight.

### **Inorganic Filler**

The bezel and optionally the housing can further comprise inorganic filler in an embodiment. The inorganic filler can improve thermal conductivity and/or strength of the molded parts. The inorganic filler can be thermal conductive  
10 filler in another embodiment. The thermal conductive filler can be selected from the group consisting of talc, kaolin, wollastonite, silica, silicon, calcium carbonate, potassium titanate, mica, magnesium oxide, calcium fluoride and a mixture thereof in another embodiment. The thermally conductive filler can be selected  
15 from the group consisting of talc, mica, kaolin and a mixture thereof in another embodiment. The bezel and optionally housing comprises no inorganic filler in another embodiment.

The inorganic filler is 1 to 80 parts by weight in an embodiment, 3 to 70 parts by weight in an embodiment, 4 to 50 parts by weight in another embodiment, 5 to 25 parts by weight in another embodiment as the  
20 thermoplastic resin is 100 parts by weight.

The inorganic filler can be a reinforcing agent in another embodiment. The reinforcing agent can be selected from the group consisting of glass fiber, carbon fiber, glass flake, glass beads and a mixture thereof in an embodiment. The reinforcing agent can be glass fiber in another embodiment.

**Additive**

One or more optional compounds selected from a wide variety of materials tailored for different applications of the resin compositions can be contained in the composition according to the present invention. Typically, 5 additive compounds can include flame retardants, impact modifiers, viscosity modifiers, heat resistance improvers, lubricants, antioxidants and UV-and other stabilizers. The compositions of the present invention may have such additive compounds in such amounts that they do not harm their characteristic properties. These and other additives are used in accordance with accepted practices as 10 understood by those having skill in the art.

**Resin Composition**

The thermoplastic resin and the colorant are mixed together to form a resin composition. The resin composition is molded into a shape of the bezel and/or the housing.

15 The thermoplastic resin can be 50 to 99.95 wt. % based on the weight of the resin composition in an embodiment. The thermoplastic resin can be 60 wt. % or more in another embodiment, 70 wt. % or more in another embodiment, 80 wt. % or more in another embodiment, 90 wt. % or more in another embodiment, 99 wt. % or more in another embodiment based on the weight of 20 the resin composition. The thermoplastic resin can be 99.9 wt. % or less in another embodiment based on the weight of the resin composition.

**EXAMPLES**

The present invention is illustrated by, but is not limited to, the following



examples.

### Example 1

The thermoplastic resin composition was prepared with the following procedure. 100 parts by weight of PBT pellets (Crastin®, E.I. DuPont de Nemours and Co.) and 0.2 parts by weight of a colorant dye were mixed in a stainless tumble mixer with stirring for one hour. The colorant dye was a mixture of an anthraquinone blue dye (C. I. Solvent blue 87), an anthraquinone yellow dye (C. I. Solvent yellow 163) and a perinone dye (C. I. Solvent red 179). The weight ratio of the colorants was blue:yellow:red=3.8:2.3:1.5. The resin composition was then injection molded to form a plate, 16 mm wide, 16 mm long and 1 mm thick, using K50-C produced by Kawaguchi Steel K.K.. The cylinder temperature was set to 250 °C. Molding temperature was 60 °C.

### Measurement

Thermal conductivity (TC): The thermal conductivity of the molding obtained above was measured by a xenon flash apparatus (LFA 447 NanoFlash®, NETZSCH company) according to ASTM E-1461. Surface temperature (ST): The plates were exposed to 1W near-infrared laser of wave length of 940 nm for 3 seconds.

### Comparative Example 1 to 5

A plate was formed in a same manner as Example 1 except for using different composition as shown in Table 1. A colorant was carbon black and additionally a thermal conductive filler (TC filler) such as talc, MgO or CaF<sub>2</sub> was added to the composition. TC and ST were measured as well as Example 1.

### Results

Thermal conductivity of the plate was higher in Comparative Example (Com. Ex.) 2 to 5 where the plate comprised the TC filler than the plate in Comparative example 1 and Example (Ex.) 1 where the composition did not contain the TC filler as shown in Table 6.

- 5 However, surface temperature (ST) was lower in Example 1 using the anthraquinone dye than the other plates in Comparative Example 1 to 5 using the carbon black and the TC filler.

Table 6 (parts by weight)

Composition	Com. Ex. 1	Com. Ex. 2	Com. Ex. 3	Com. Ex. 4	Com. Ex. 5	Ex. 1	
PBT	100	100	100	100	100	100	
Colorant	C-black	0.5	0.7	0.8	0.8	0.8	0.0
	Dye	0.0	0.0	0.0	0.0	0.0	0.2
TC filler	Talc	0.0	33.6	67.2	0.0	0.0	0.0
	MgO	0.0	0.0	0.0	67.2	0.0	0.0
	CaF <sub>2</sub>	0.0	0.0	0.0	0.0	67.2	0.0
TC (W/mK)	0.7	1.1	1.2	1.1	0.9	0.7	
ST (°C)	359	251	223	217	252	200	

10 Example 2, 3 and Comparative Example 6

The thermoplastic resin composition of Example 2 and Comparative Example 6 was prepared in the same manner of Example 1 and Comparative Example 1 respectively. In Example 3, the thermoplastic resin composition was prepared in the same manner of Example 1 except for increasing the dye amount to 0.3 parts by weight as shown in Table 7.

15 Measurement

Surface temperature (ST): The plates were exposed to 30 W light of a

xenon lamp concentrated to a circular area of 2.5 mm diameter on each plates for 3 seconds. The results are shown in Table 7 as relative values when the ST of Comparative Example 6 is 100.

Results

- 5 Surface temperature (ST) was lower in Example 2 and 3 using the anthraquinone dye than Comparative Example 6 using the carbon black.

Table 7 (parts by weight)

Composition		Com. Ex. 6	Ex. 2	Ex. 3
PBT		100	100	100
Colorant	C-black	0.5	0.0	0.0
	Dye	0.0	0.2	0.3
ST (°C)*		100	69	72

\*Relative value when the ST of Comparative Example 6 is 100.

**CLAIMS**

What is claimed is:

1. A vehicle headlight assembly comprising:
  - 5 a light source,
  - a housing supporting the light,
  - a bezel equipped over the front side of the housing, and
  - a transparent cover being equipped over the front side of the bezel,wherein the bezel and optionally the housing comprises a thermoplastic resin  
10 and a colorant, wherein the colorant is selected from the group consisting of an anthraquinone dye, an amine salt thereof and a mixture thereof.
  
2. The vehicle headlight assembly of claim 1, wherein the thermoplastic resin comprises polyamide, polyester, polyphenylene sulfide, polyacetal,  
15 polycarbonate, polysulfone, polyethylene, polyether sulfone, methacrylate, polyamide-imide, fluoroplastic and a mixture thereof
  
3. The vehicle headlight assembly of claim 1, wherein the thermoplastic resin comprises polyamide, polyester and a mixture thereof.  
20
  
4. The vehicle headlight assembly of claim 1, wherein the anthraquinone dye is represented by the following formula [I], formula [II-a] or formula [II-b].

Formula [I]

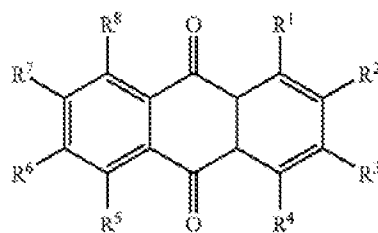

wherein R<sup>1</sup> to R<sup>8</sup> is independently H, OH, NH<sub>2</sub>, OCH<sub>3</sub>, CH<sub>3</sub>NH, C<sub>4</sub>H<sub>9</sub>NH, C<sub>5</sub>H<sub>11</sub>NH, Br, NOC<sub>2</sub>H<sub>4</sub>NH, methylanilino, aniline, benzoylamido, ethylanilino,  
 5 cyclohexyl amido or phenyloxy.

Formula [II-a]

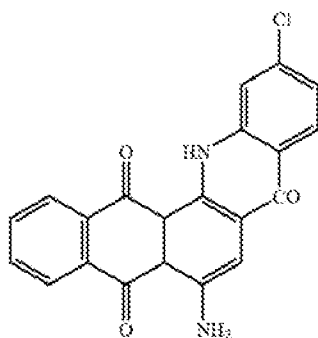

Formula [II-b]

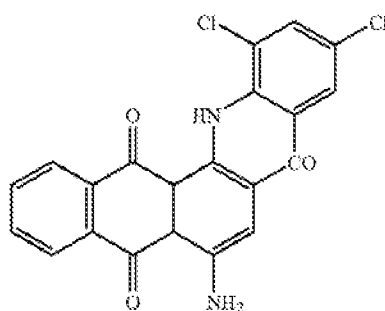

10

5. The vehicle headlight assembly of claim 1, wherein the anthraquinone dye is selected from the group consisting of an anthraquinone green dye, an anthraquinone blue dye, an anthraquinone violet dye, an anthraquinone red dye,

an anthraquinone orange dye, an anthraquinone yellow dye and a mixture thereof.

6. The vehicle headlight assembly of claim 5, wherein the anthraquinone green dye is selected from the group consisting of C.I. Solvent Green 3, 5, 6, 7, 19, 20, 22, 23, 24, 25, 26, 28, 29 and a mixture thereof.

7. The vehicle headlight assembly of claim 5, wherein the anthraquinone blue dye is selected from the group consisting of C.I. Solvent Blue 11, 12, 13, 14, 16, 17, 18, 19, 20, 21, 35, 36, 40, 41, 45, 58, 59, 63, 65, 68, 69, 74, 76, 78, 79, 80, 82, 83, 84, 85, 86, 87, 90, 91, 92, 93, 94, 95, 96, 97, 98, 101, 102, 103, 104, 105, 106, 107, 108, 109, 110, 111, 112, 113, 114, 116, 119, 120, 121, 122, 123, 126, 128, 130, 132, 134, 136, 139, C.I. Vat Blue 4, 6, 11, 12, 13, 14 and a mixture thereof.

15

8. The vehicle headlight assembly of claim 5, wherein the anthraquinone violet dye is selected from the group consisting of C.I. Solvent Violet 11, 12, 13, 14, 15, 26, 28, 30, 31, 33, 34, 36, 37, 38, 40, 41, 42 and a mixture thereof.

20 9. The vehicle headlight assembly of claim 1, wherein the thermoplastic resin is 100 parts by weight and the colorant is 0.01 to 12 parts by weight.

10. The vehicle headlight assembly of claim 1, wherein the bezel and optionally the housing further comprises an additional colorant selected from the group

consisting of perinone dye, an azo dye and a mixture thereof.

11. The vehicle headlight assembly of claim 10, wherein the additional colorant is 0.01 to 3 parts by weight.

5

12. A vehicle bezel comprising a thermoplastic resin and a colorant, wherein the colorant is selected from the group consisting of an anthraquinone dye, an amine salt thereof and a mixture thereof.

10 13. A method of manufacturing a vehicle headlight assembly comprising steps of:

preparing a thermoplastic resin composition comprising a thermoplastic resin and a colorant, wherein the colorant is selected from the group consisting of an anthraquinone dye, an amine salt thereof and a mixture thereof;

15 forming a bezel by injection molding the resin composition;  
equipping the bezel on the front side of a housing holding a light; and  
equipping a transparent cover on the front side of the bezel.

FIG. 1

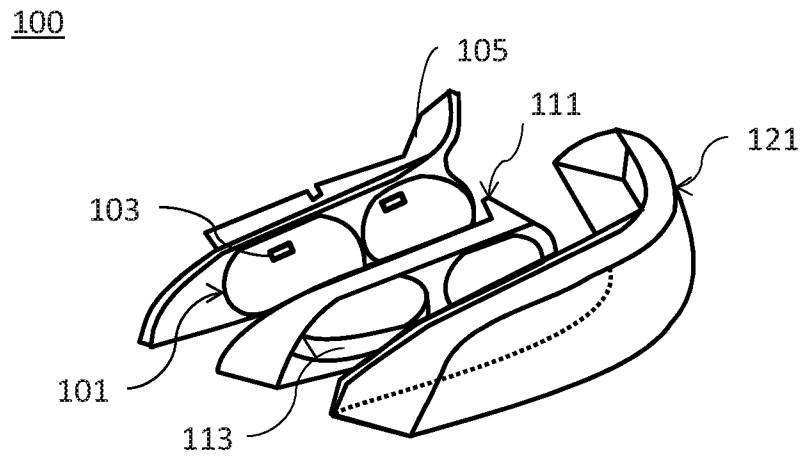



## INTERNATIONAL SEARCH REPORT

International application No.  
**PCT/US2017/023141****A. CLASSIFICATION OF SUBJECT MATTER****C08K 5/00(2006.01)i, C09B 5/60(2006.01)i, F21S 8/10(2006.01)i, C08K 5/08(2006.01)i, C08K 5/3437(2006.01)i, C08L 77/00(2006.01)i, C08L 67/00(2006.01)i**

According to International Patent Classification (IPC) or to both national classification and IPC

**B. FIELDS SEARCHED**

Minimum documentation searched (classification system followed by classification symbols)

C08K 5/00; C09B 67/22; C08L 69/00; C08L 51/04; C08L 55/02; C08L 67/00; B60Q ; F21V 15/06; C09B 5/60; F21S 8/10; C08K 5/08; C08K 5/3437; C08L 77/00

Documentation searched other than minimum documentation to the extent that such documents are included in the fields searched

Korean utility models and applications for utility models

Japanese utility models and applications for utility models

Electronic data base consulted during the international search (name of data base and, where practicable, search terms used)

eKOMPASS(KIPO internal), STN(Registry, Caplus), Google &amp; keywords: headlight, light source, housing, bezel, cover, colorant, anthraquinone, thermoplastic, injection

**C. DOCUMENTS CONSIDERED TO BE RELEVANT**

Category*	Citation of document, with indication, where appropriate, of the relevant passages	Relevant to claim No.
X	WO 03-099939 A1 (SATURNUS-AVTOOPREMA PROIZVODNJA SVETLOBNE OPREME ZA MOTORNA IN DRUGA VOZILA D.D. LJUBLJANA) 4 December 2003 See pages 2, 7, 9; and claims 1-8.	12
Y		1-11, 13
Y	WO 03-086813 A2 (GENERAL ELECTRIC COMPANY) 23 October 2003 See claim 1; page 12; and figure 2.	1-11, 13
A	WO 2013-115903 A1 (SABIC INNOVATIVE PLASTICS IP B.V.) 8 August 2013 See the whole document.	1-13
A	WO 2014-108867 A1 (SABIC INNOVATIVE PLASTICS IP B.V.) 17 July 2014 See the whole document.	1-13
A	WO 2008-008599 A2 (GENERAL ELECTRIC COMPANY) 17 January 2008 See the whole document.	1-13

 Further documents are listed in the continuation of Box C. See patent family annex.

\* Special categories of cited documents:

"A" document defining the general state of the art which is not considered to be of particular relevance

"E" earlier application or patent but published on or after the international filing date

"L" document which may throw doubts on priority claim(s) or which is cited to establish the publication date of another citation or other special reason (as specified)

"O" document referring to an oral disclosure, use, exhibition or other means

"P" document published prior to the international filing date but later than the priority date claimed

"T" later document published after the international filing date or priority date and not in conflict with the application but cited to understand the principle or theory underlying the invention

"X" document of particular relevance; the claimed invention cannot be considered novel or cannot be considered to involve an inventive step when the document is taken alone

"Y" document of particular relevance; the claimed invention cannot be considered to involve an inventive step when the document is combined with one or more other such documents, such combination being obvious to a person skilled in the art

"&amp;" document member of the same patent family

Date of the actual completion of the international search

04 July 2017 (04.07.2017)

Date of mailing of the international search report

**04 July 2017 (04.07.2017)**

Name and mailing address of the ISA/KR

International Application Division  
Korean Intellectual Property Office  
189 Cheongsa-ro, Seo-gu, Daejeon, 35208, Republic of Korea

Facsimile No. +82-42-481-8578

Authorized officer

LEE, Ki Cheul

Telephone No. +82-42-481-3353



## INTERNATIONAL SEARCH REPORT

Information on patent family members

International application No.

PCT/US2017/023141

Patent document cited in search report	Publication date	Patent family member(s)	Publication date
WO 03-099939 A1	04/12/2003	AT 412034 T	15/11/2008
		AU 2003-273175 A1	12/12/2003
		EP 1529081 A1	11/05/2005
		EP 1529081 B1	22/10/2008
		SI 1529081 T1	30/04/2009
		SI 21240 A	31/12/2003
WO 03-086813 A2	23/10/2003	AT 358799 T	15/04/2007
		AT 376647 T	15/11/2007
		AU 2003-230694 A1	27/10/2003
		AU 2003-230694 B2	14/08/2008
		AU 2004-284404 A1	06/05/2005
		CA 2540700 A1	06/05/2005
		CN 100538154 C	09/09/2009
		CN 1659406 A	24/08/2005
		CN 1659406 B	15/12/2010
		CN 1890505 A	03/01/2007
		DE 602004005730 T2	27/12/2007
		DE 60317054 T2	07/08/2008
		EP 1494891 A2	12/01/2005
		EP 1494891 A4	27/07/2005
		EP 1494891 B1	24/10/2007
		EP 1671059 A1	21/06/2006
		EP 1671059 B1	04/04/2007
		JP 2005-522831 A	28/07/2005
		JP 2007-507847 A	29/03/2007
		JP 4463821 B2	19/05/2010
		KR 10-1025419 B1	28/03/2011
		KR 10-1060420 B1	29/08/2011
		KR 10-2004-0107490 A	20/12/2004
		KR 10-2007-0030731 A1	16/03/2007
		TW 200306263 A	16/11/2003
		US 2003-0189838 A1	09/10/2003
		US 2004-0095779 A1	20/05/2004
		US 2006-0077680 A1	13/04/2006
		US 6893147 B2	17/05/2005
		US 7168833 B2	30/01/2007
US 7278762 B2	09/10/2007		
WO 03-086813 A3	24/12/2003		
WO 2005-040674 A1	06/05/2005		
WO 2013-115903 A1	08/08/2013	CN 104093782 A	08/10/2014
		CN 104093782 B	01/03/2017
		EP 2809721 A1	10/12/2014
		KR 10-2014-0127300 A	03/11/2014
		US 2013-0203909 A1	08/08/2013
US 9085687 B2	21/07/2015		
WO 2014-108867 A1	17/07/2014	CN 104918999 A	16/09/2015

**INTERNATIONAL SEARCH REPORT**

Information on patent family members

International application No.

**PCT/US2017/023141**

Patent document cited in search report	Publication date	Patent family member(s)	Publication date
		CN 104918999 B	26/04/2017
		EP 2943533 A1	18/11/2015
		KR 10-2015-0104629 A	15/09/2015
		US 2014-0200303 A1	17/07/2014
WO 2008-008599 A2	17/01/2008	AT 478119 T	15/09/2010
		CN 101501135 A	05/08/2009
		CN 101501135 B	04/07/2012
		EP 2057231 A2	13/05/2009
		EP 2057231 B1	18/08/2010
		KR 10-1458122 B1	04/11/2014
		KR 10-2009-0029298 A	20/03/2009
		KR 10-2014-0096128 A	04/08/2014
		US 2008-0011513 A1	17/01/2008
		US 7816444 B2	19/10/2010
		WO 2008-008599 A3	20/03/2008