

(19)
(12)

(KR)
(B1)

(51) 。 Int. Cl.⁷
E04G 21/14

(45)
(11)
(24)

2004 10 14
10-0452914
2004 10 05

(21) 10-2002-0044955
(22) 2002 07 30

(65)
(43)

10-2003-0019859
2003 03 07

(30) JP-P-2001-00259736 2001 08 29 (JP)

(73) 가 가 6-7

(72) 가 가 2-9-2

1 2 7 가 가 가

1 2 7 가 가 가

1 2 7 가 가 가

2 15 2 가 가

(74)

:

(54)

가 , 가 가
(22) 가 (24), (22) (24)
(11) (25) 가 (懸垂) (21) , (22) (hoisting)
accessory) (13) (24) (57) 가 (22) (端) (11)
(21) (11) (62) (21) 180° ,
(11) (62)

1 (A), (B)

1

2

3

(懸垂)

4

5 (A), (B)

6 (A), (B), (C), (D)

7 (E), (F), (G), (H)

8 (I), (J), (K), (L), (M)

9 2

10 (A), (B)

3

11

12 (A), (B)

13 (A), (B)

< >

10: , 11: , 11A: 1 , 11B: 2 , 11C: 3
 , 11D: 4 , 11E: 5 , 11F: 6 , 12: , 12A: (滑車) , 12B:
 , 12C: , 12D: , 12E: , 12D: , 12F: U , 12G: , 13:
 , 14: , 15: , 16: , 17: , 17A: , 18:
 19: , 20: , 21: , 22: , 22A: , 22B: , 22C: , 23:
 , 24: , 25: , 26: 가 (架臺), 27: 1 , 27A: , 27B: , 28:
 2 , 28A: , 28B: , 29: 3 , 29A: , 29B: , 30: 4 , 3
 0A: , 30B: , 31, 32: , 33, 34: , 35, 36: , 37: , 38, 39: , 40, 4
 1: , 42: 1 , 43: 2 , 44, 45: , 46, 47: , 48: , 49, 50:
 , 51, 52: , 53: 3 , 54: 4 , 55, 56: , 57: , 57A: , 58: , 59:
 , 60: , 61: , 62: , 65: , 66:
 , 67: , 68: , 69: 가 , 70: , 71: , 71A: , 71
 B: , 72: , 73: , 74: , 75: 1 , 75A: , 76: 2
 , 76A: , 77: 3 , 77A: , 78: 4 , 78A: , 79, 80:
 81: 1 , 82: 2 , 83, 84: , 85, 86: , 87, 88: , 89: 3 , 90: 4
 , 91, 92: , 93, 94: , 95:

, 1

6(1994)-322989

8(1996)-209940

, 1 가

6-322989

가

(端部)

가

가

8-209940

가

1

가

가

가

가

가

가

가

가

(懸垂)

(端)

180

가

6

180°

가

(折曲) 가

가

가

가

가

가

가

가

가

가

가
 , 가 , 가
 , 가 , 가 (hoisting accessory)
 , 가 , 가
 , 가
 , 180°
 가 , 가 , 가
 , 가 (3 30MHz) ()
 , 가
 , 가
 , 가
 , 1 (A), (B) 1
 , 2 , 3
 , 4
 , 5 (A), (B)
 H) , 6 (A), (B), (C), (D) , 7 (E), (F), (G), (H)
 , 8 (I), (J), (K), (L), (M)
 , 9 2
 , 10 (A), (B) 3
 , 11
 , 12 (A), (B) , 13 (A), (B)
 1 (A), (B) , 1 (10)
 (11) , 가
 (12) (12) 13 (12A)
 (12B) (12C) (12B) (12D)
 (12E) (12D) (12) U
 (12F) (12E) (12G) , U (12F) (12F)
 (12B) (12) . U (12F)
 (12E) (12G) (12)
 (13) (13) (14) 가 ,
 (15) 가 .
 2, 3, 4 (14) , 180°
 (16)가 (15)
 (17) , (17) (17A) (14)
 (17) (14) (15)가
 (16) (15) (15)가 180° ()
 가 (18)가 (15)가 (14) 180°
 (15) 4 (19) (20)가 ,
 2 (15) (19) (21) (21)
 (22A) , 2 (22A) (22B) 4

(22) , 4 (19) (23)가
 , 2 (22A) (22C)가 (22) ()
 가 (24)가 (22)
 1 [11(1, 2 (11A, 11b))] (25)
 (11) (微) 가 (22) 가 (26)가
 3, 4 (24) (22)
 1, 2 (27, 28) , 1, 2 (27, 28) 가
 3, 4 (29, 30) 2 가 1, 2 ((27A, 28A)
 27, 28) (22) (22A) , 2 (27A, 28A) , 2 (27A, 28A)
 (27B, 28B) □ 1, 2 (27, 28)
 (31, 32) [22((22A), (22C))] (33, 34)
 (35, 36) (31, 32) , 1, 2 (27, 28)가 (35, 36)
 5, 36) 가 (35, 36) (22) (27, 28)가 (35, 36)
 B) , 1, 2 (27, 28) (31, 32) (22) (22)
 , 500 900mm (27, 28) (22) [11(3, 4 (11C, 11D))] (25)
 가 (26) 1, 2 (27, 28) (37)가 (27, 28) , 1, 2 (27, 28)
 , 1, 2 (27, 28) (27, 28) (25) 3, 4 (11C, 11D)가 , 1, 2 (27, 28) 가
 2 (27, 28) (基部)가 (37) , 1, 2 (27, 28) (22) 1, 2 (27, 28)
 (27, 28) , (35, 36) 가 1, 2 (27, 28)
 (31, 32) (38, 39) , 가 (26)
 (40, 41) , 1, 2 (42, 43) (38, 39) (40, 41)
 (38, 39) , 1, 2 (42, 43) (44, 45) , (38, 39)
 (40, 41) (35, 36) 1, 2 (22)
 (27, 28) , 1, 2 (27, 28) (27, 28)가 (22)
 (3 2) , 1, 2 (27, 28)가 (22)
 3, 4 (29, 30) 1, 2 (27, 28) , 2 (29A
 , 30A) , 2 (29A, 30A) (29B, 30B) □ (27, 28)
 3, 4 (29, 30) (46, 47) , 1, 2 (27, 28)
 3, 4 (22) (33, 34) (35, 36) (46, 47)
 3, 4 (29, 30)가 (35, 36) 가 (35, 36) (22)
 1, 2 (27, 28) , 3, 4 (29, 30) (46, 47)
 (29, 30) 1, 2 (27, 28) (27B, 28B) , 3, 4 (46, 47)
 , 500 900mm (25)
 [11(5, 6 (11E, 11F))] (25)
 가 (26) 3, 4 (29, 30) (48)가 (29, 30) , 3, 4 (11E, 11F)가 , 3, 4 (29, 30) 가 , 3, 4 (29, 30) 가
 , 3, 4 (29, 30) 가 (26) (25) 5, 6 (11E, 11F)가 , 3, 4 (29, 30) 가 (27, 28) [(27B, 28B)]
 3, 4 (29, 30) (46, 47) , (35, 36) 가 (49, 50) , 가
 (26) (51, 52) , 3, 4 (53, 54) (49, 50)
 (51, 52) , 3, 4 (53, 54) (55, 56)
 , (35, 36) 3, 4 (29, 30) , 5 (A),
 (B) , 3, 4 (29, 30) (22)
 , 3, 4 (29, 30)가 (22)
 (22) 가 (26) (13), (24)
 , (57) , (57A) (13), (21)
 , (22) (22) (13) (24)
 , (58) , (58) (58) 1 4 (42, 43, 53, 54)
 (58) , (59) (59) (60)가
 (58) , (3 30MHz) ()
 가

, 1 (10)

(1) , 1, 2 (21) (12) (27, 28) (22) 3, 4 (1) (29, 30) (25) (11) 가 () [5 (A), (B)] , [11(1, 2 (11A, 1 1B))]]

(2) , 1, 2 (22) (42, 43) (44, 45) 1, 2 (27, 28)

(3) 1, 2 (27, 28) (25) [11(3, 4 (11C, 11D))] , 1, 2 (11A, 11B) (11A, 11B) 3, 4 (11C, 11D)가 (61) , 1, 2 (53, 54) (55, 56) 3, 4 (29, 30) , 1 , 2 (27, 28)

(4) 3, 4 (27, 28) (11C, 11D) (61) , (22) 3, 4 (29, 30) , 1 (A), (B) (29, 30) (25) [11(5, 6 (11E, 11F))] , 1 (A), (B)

(5) 3, 4 (29, 30) (11C, 11D) (25) (61) , (22) 3, 4 (29, 30) , 1 (A), (B)

(6) 6 (A) (62) (29) 5, 3 (11E) (29) (21) 5 (11E) (62) 5 (11E) (62) (25) 5 (11E)

(7) 6 (B) (58) , 3 (53) (55)

(8) , 3 (29) (35) (58) (13) (15) (14) (17)가 , (15)가 (14) (16) , 180° (15) (18)가 (14) (21) 180° , 4 (30) 6 (11F)가 (62) [6 (C)] . [6 (D)] .

(9) 7 (E) (58) , 4 (54) (56)

(10) 7 (F) (62) , 4 (30) (36) 2 (28) 4 (11D)

(11) 7 (G) , 2 (28) (36) (58) , 2 (43) (45)

(12) 7 (H) , 2 (28) (36) (58) , (13) (27) 3 () 15 (11C) (62) (21) 180° , 1 [8 (I)] .

(13) 8 (J) , 1 (27) (35) (58) , 1 (42) (44)

(14) 8 (K) , 1 (27) (35) (22) 1 (11A)

(15) 8 (M) [8 (L)] , (58) (13) () 15 (62) (21) 180° , (22) 2 (11B)

9 , 2 (11)가 (62) (65) (21)

1 (10) (22) (66) (10) , 1 (66) (10) (22) 4 , (67) (68) 가 가 (69) (13) (19) 가 (23)가

3 (29) 5 (11E) (62) (6 (B)) , (55) , 3 (29) (29) (11)가 , 3 (11)가 (22) 5 (11E)가 () 2 (22) (11)가 , 3 (21) (重心)

(21) 가 (22)
 (60) (23) (60) 1200mm (21) 2 3°
 (21) (23) (67) 가
 (69) (21) (d) ,
 $d = \tan 3^\circ \times 1200 = 0.0524 \times 1200 = 63$
 (67) 가 (69) 63mm (23) (67)
 7 (E) 가 가 (21) 가 (21)
 가 (69) 가 (21) 가 (21)
 7 (G), 8 (L) 가 (69) (23)
 (67) 가 (23)
 가
 10 (A), (B), 11 3
 (70) 1 (10) (22)
 가 (24) (21) (71) 가
 (72) (73) 1
 (10)
 (73) 가 (74)
 (71) 가 (71) 가 [10 (A)] 가 (74)
 가 1, 2 (75, 76) , 1, 2
 (75, 76) 3, 4
 (77, 78) 2 가 (75, 76) (72) , 1, 2 (75,
 76)가 (74) 가 1 4
 (75, 78) (75A, 76A, 77A, 78A)가 , 3, 4
 (77, 78)가 1, 2 (75, 76) (75A, 76A) 가
 (71) 4 (19) (23)가 ((71)
 71) (79, 80) , 1, 2 1, 2 (81, 82)
 2 (81, 82) 가 (85, 86) (75, 76) (83, 84) 1,
 (71A, 71B)가 , (85, 86) (83, 84)가 (71)
 , 1, 2 (75, 76) (75, 76) (71) (75, 76)
 가 (87, 88) , 3, 4 가
 (89, 90) , 3, 4 (77, 78) (91, 92) 3,
 4 (89, 90) 가 (93, 94) , 3, 4 (93, 94) 3, 4 ((75, 76)
 77, 78) 가 , 3, 4 (77, 78) 1, 2 (75, 76)
 가 (71) , 1 4 (75, 76, 77, 78) (7
 4, 75A, 76A, 78A) (11) (95)
 , 3 (70)
 (1) 12 (B) , 1, 2 (81, 82), 3, 4 (87, 88) (85,
 86, 93, 94) , (71) (93) 1, 2 (11A, 11B)
 (2) 12 (A) , 1, 2 (81, 82) (83, 84) 1, 2
 (75, 76) (71) , (95) 3, 4 (11C, 11D)
 , 1, 2 (11A, 11B) (61) , 1, 2 (11A,
 11B) 3, 4 (11C, 11D)가
 (3) 10 (B) , 3, 4 (89, 90) (93, 94) 3, 4 ((75, 76)
 77, 78) 1, 2 (75, 76) , (95) 5, 6 ((71)
 11E, 11F) , 3, 4 (11C, 11D) (61) , 3, 4
 (11C, 11D) 5, 6 (11E, 11F)가
 (4) (73) (62) , 3 (62) , 3 ((77) 5 3 (11E) ((71)
 77) 5 (11E) (62) , 3 (77) 5 3 (11E) [(71)
 (62) , (95) 5 (11E) (77) 5 3 (11E) [(71)
 6 (A)].

가 가 가

6

가

7

가

(57)

1.

가

(懸垂)

(端)
180°

2.

1

(折曲) 가

가

3.

1

가

4.

2

3

5.

가

가

(hoisting accessory)

가

가

가

가

가

가

가

가

6.

5

가

7.

5

6

가

1

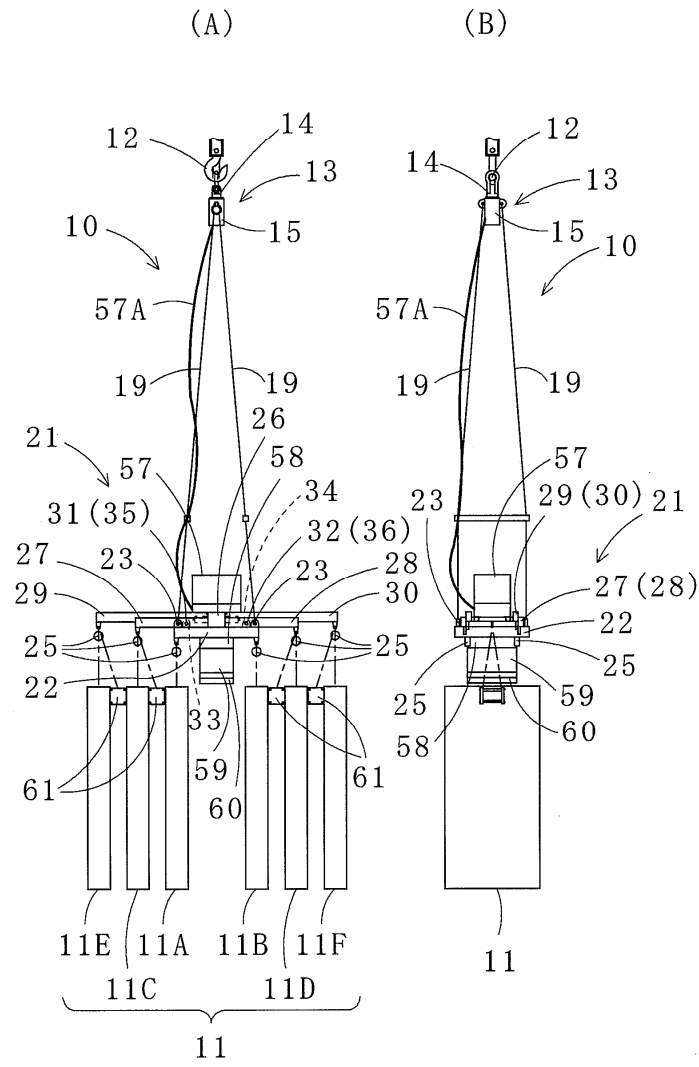

2

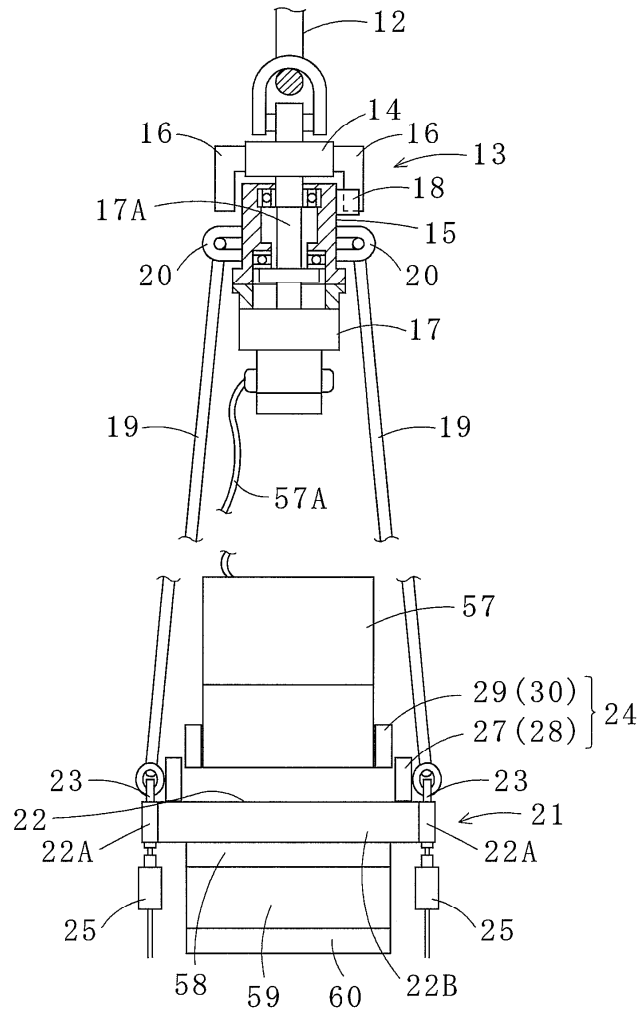

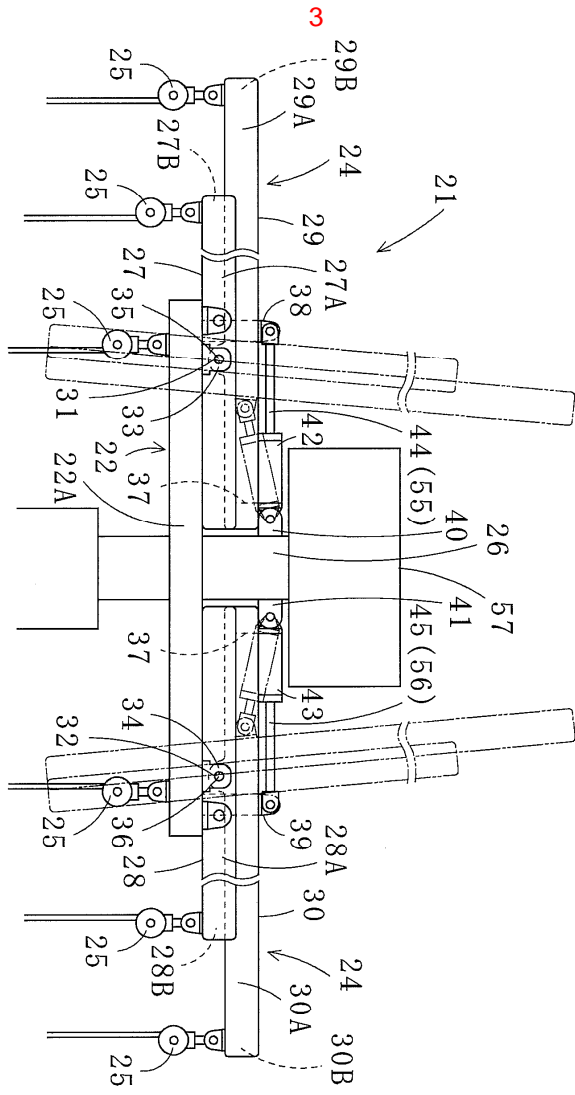

5

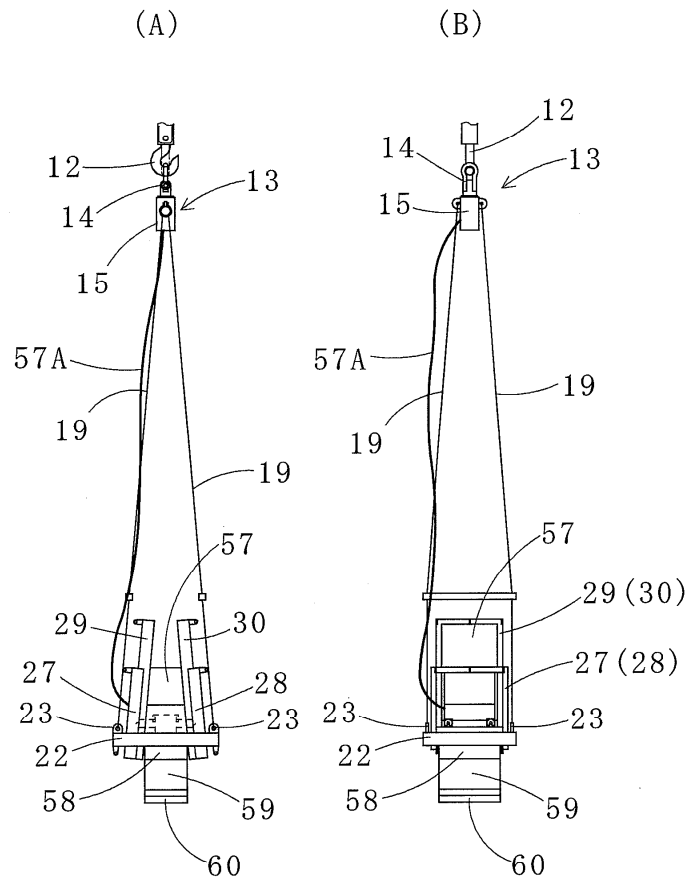

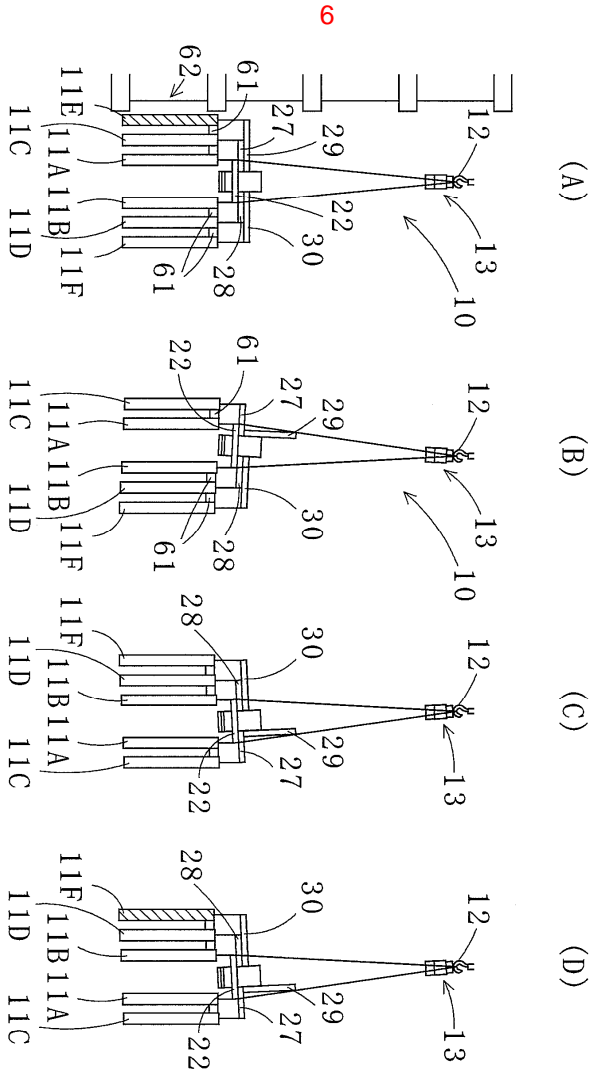

7

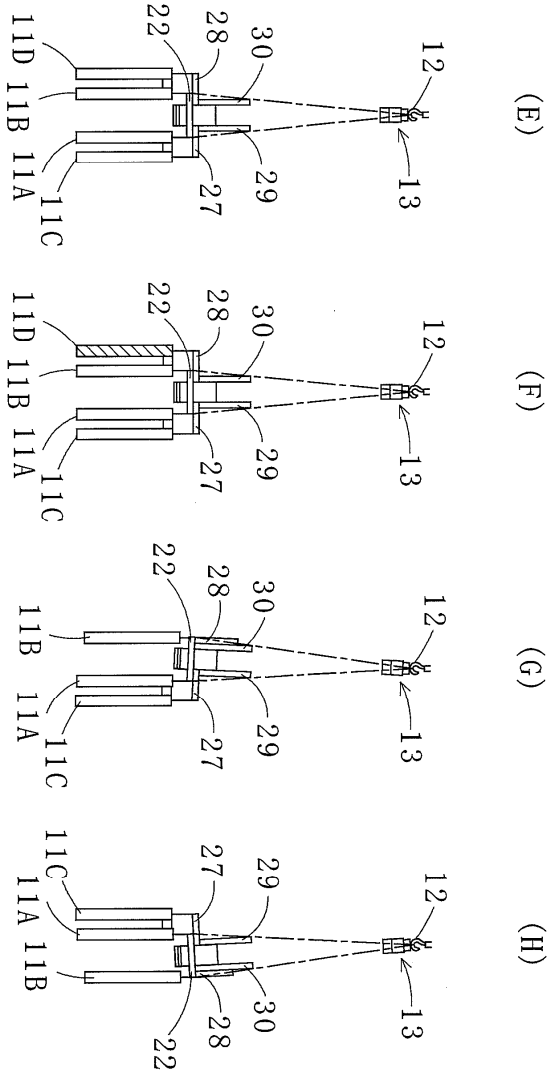

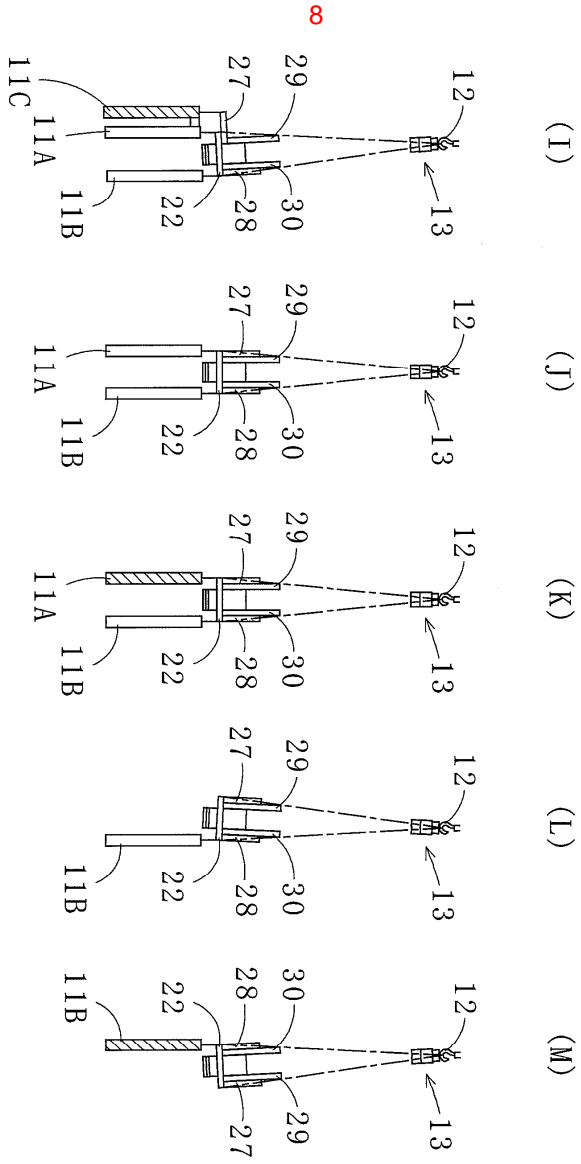

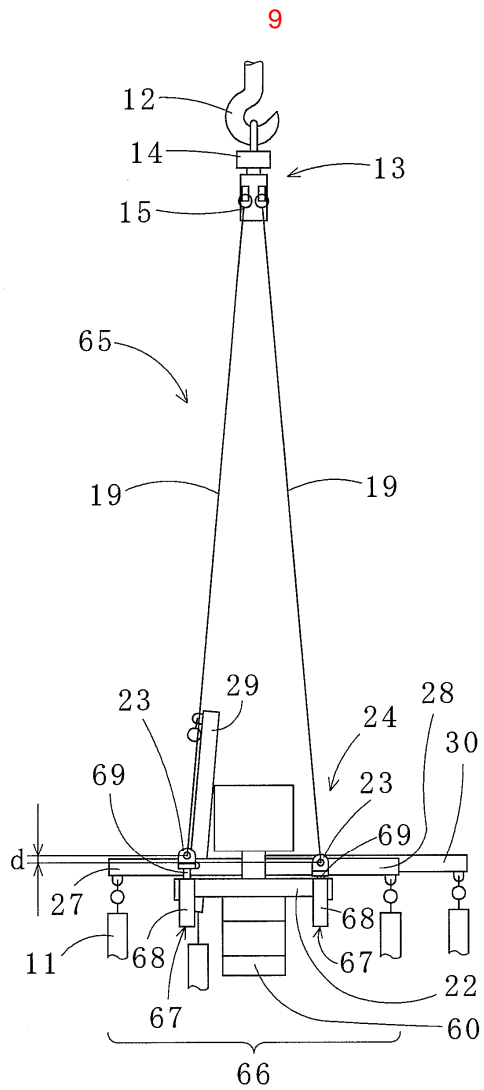

10

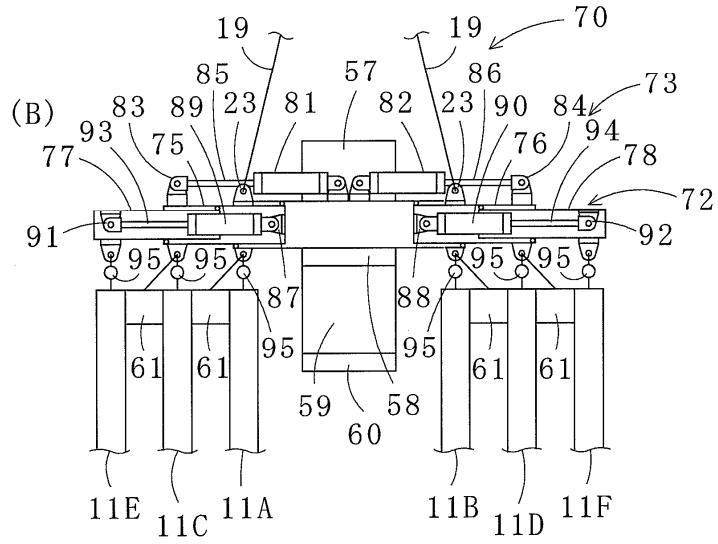
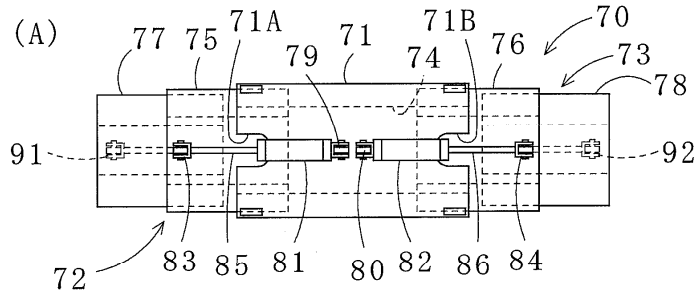

11

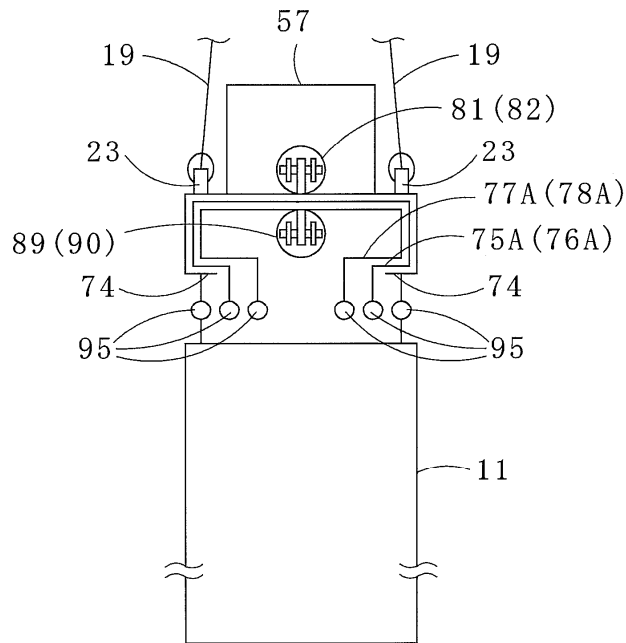

12

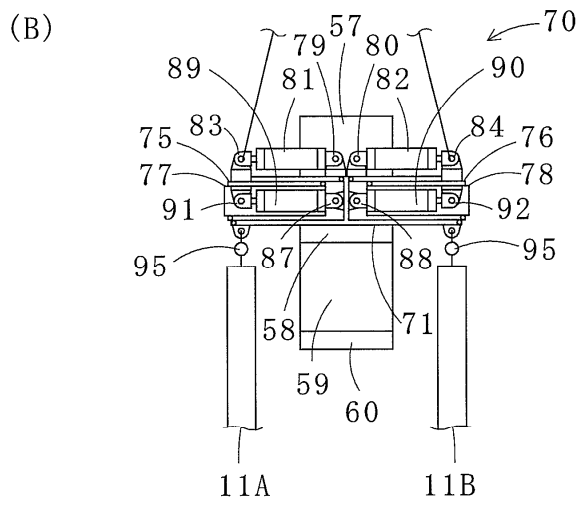
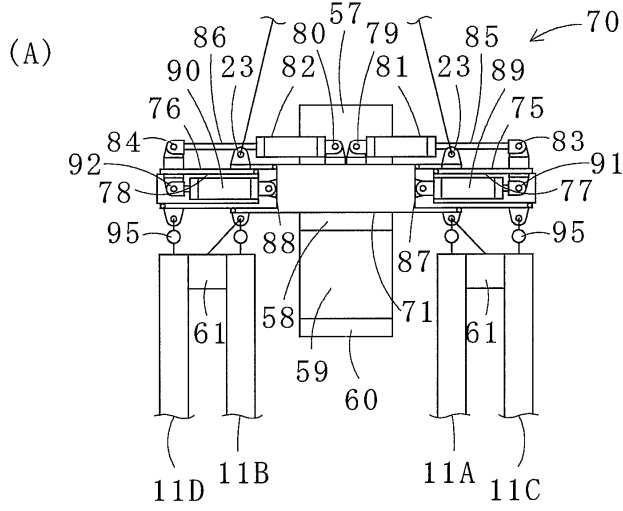

13

