



(19) **United States**

(12) **Patent Application Publication**  
Nakano et al.

(10) **Pub. No.: US 2017/0001565 A1**

(43) **Pub. Date: Jan. 5, 2017**

(54) **CAMERA APPARATUS AND IN-VEHICLE SYSTEM**

(52) **U.S. Cl.**  
CPC ..... *B60R 1/00* (2013.01); *G06K 9/00798* (2013.01); *G06K 9/00805* (2013.01); *G06K 9/00825* (2013.01); *H04N 5/2353* (2013.01); *G06K 9/00812* (2013.01); *B60R 2300/804* (2013.01); *B60R 2300/8033* (2013.01); *B60R 2300/8093* (2013.01); *B60R 2300/806* (2013.01); *B60R 2300/105* (2013.01)

(71) Applicant: **DENSO CORPORATION**, Kariya-city (JP)

(72) Inventors: **Toshihisa Nakano**, Kariya-city (JP);  
**Yasuki Furutake**, Kariya-city (JP);  
**Daisuke Takama**, Kariya-city (JP)

(21) Appl. No.: **15/198,539**

(22) Filed: **Jun. 30, 2016**

(30) **Foreign Application Priority Data**

Jun. 30, 2015 (JP) ..... 2015-131311

**Publication Classification**

(51) **Int. Cl.**  
*B60R 1/00* (2006.01)  
*H04N 5/235* (2006.01)  
*G06K 9/00* (2006.01)

(57) **ABSTRACT**

In a camera apparatus, a camera module has a predetermined field of view, and is configured to capture an image in front of the vehicle via a predetermined wiping area of the windshield of the vehicle. In the camera module, a lens unit includes a plurality of lenses. A barrel is configured to house the lens unit. An imager has an imaging surface, and is arranged with respect to the lens unit such that light passing through the plurality of lenses of the lens unit forms an image on the imaging surface. The imager includes at least part of an exposure controller that controls an exposure of the imaging surface. The imaging surface is concavely curved

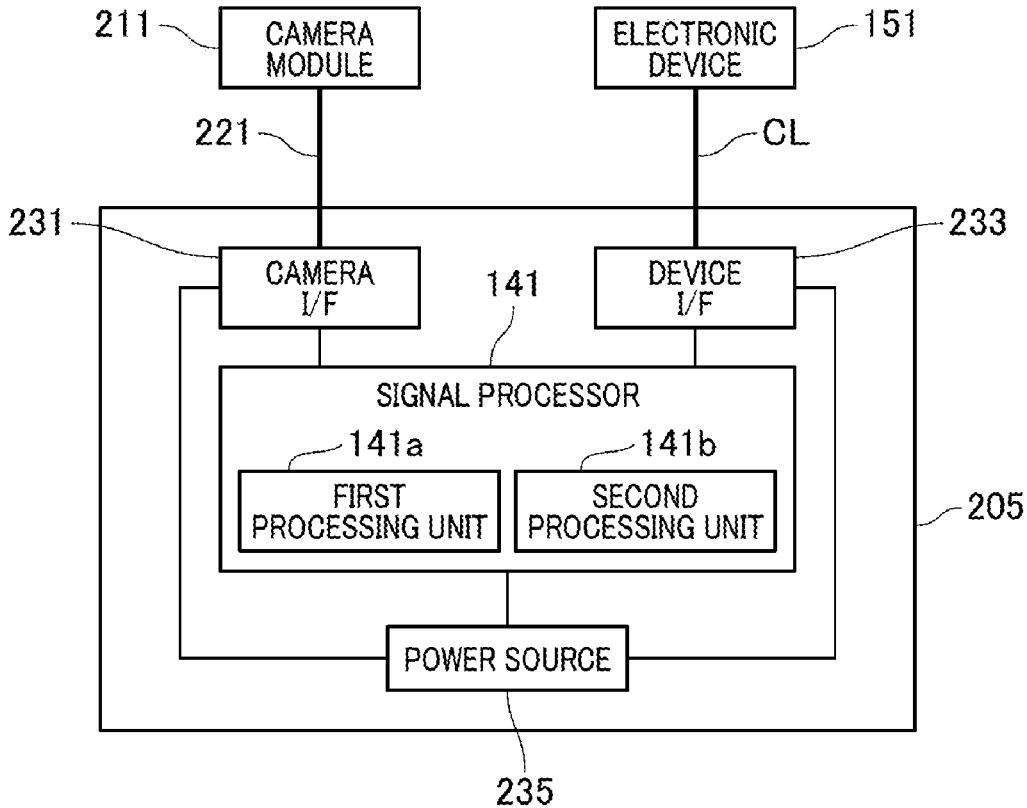

FIG. 1

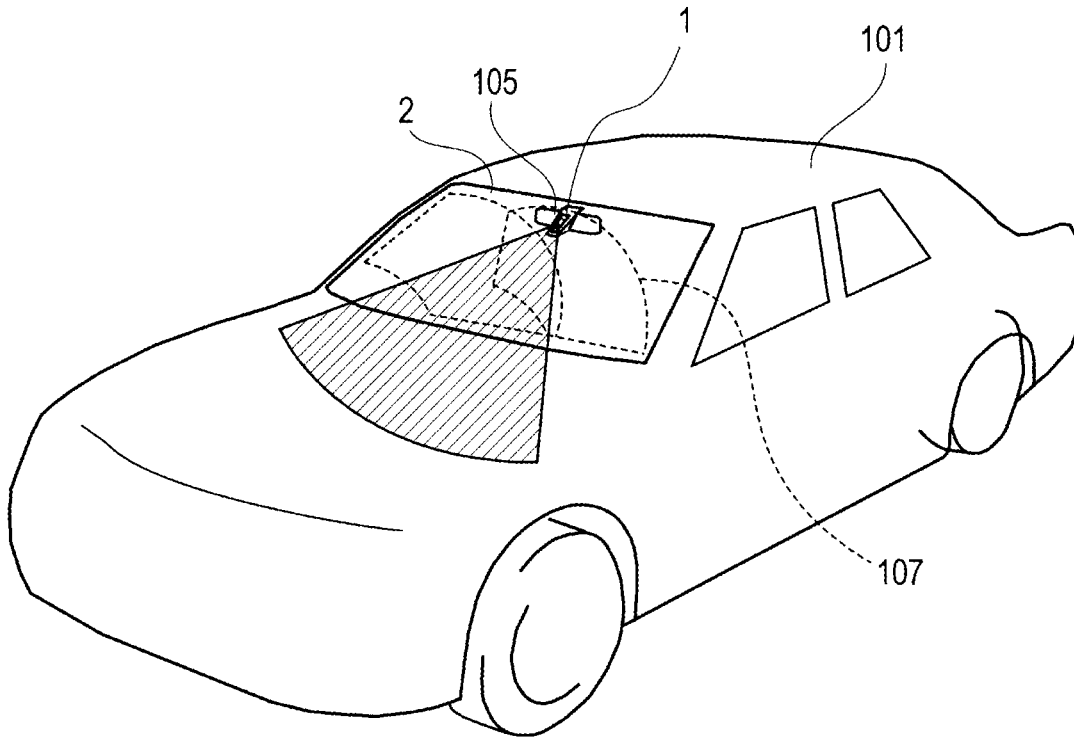

FIG. 2

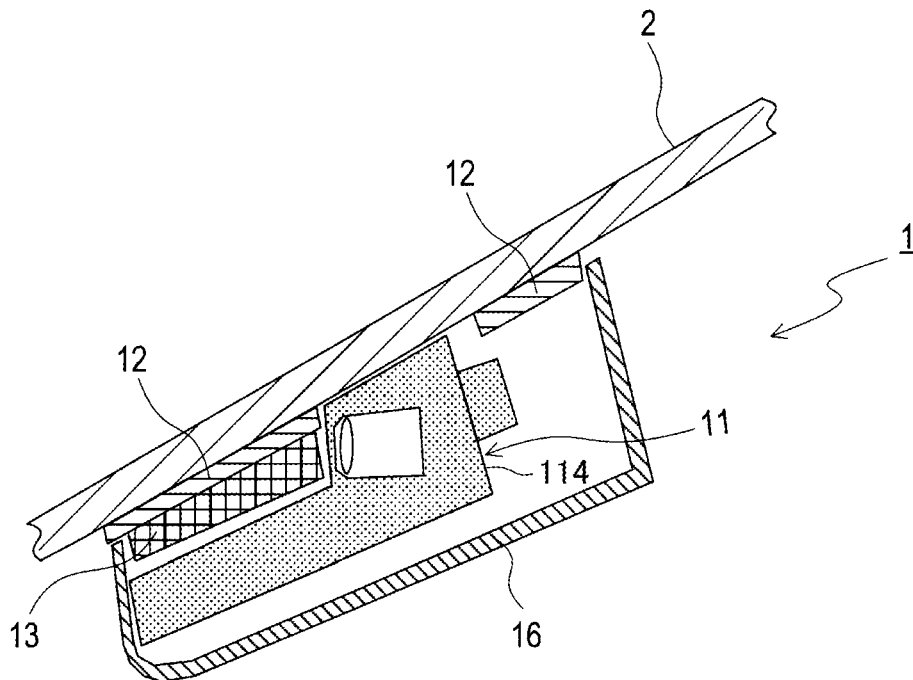

FIG. 3

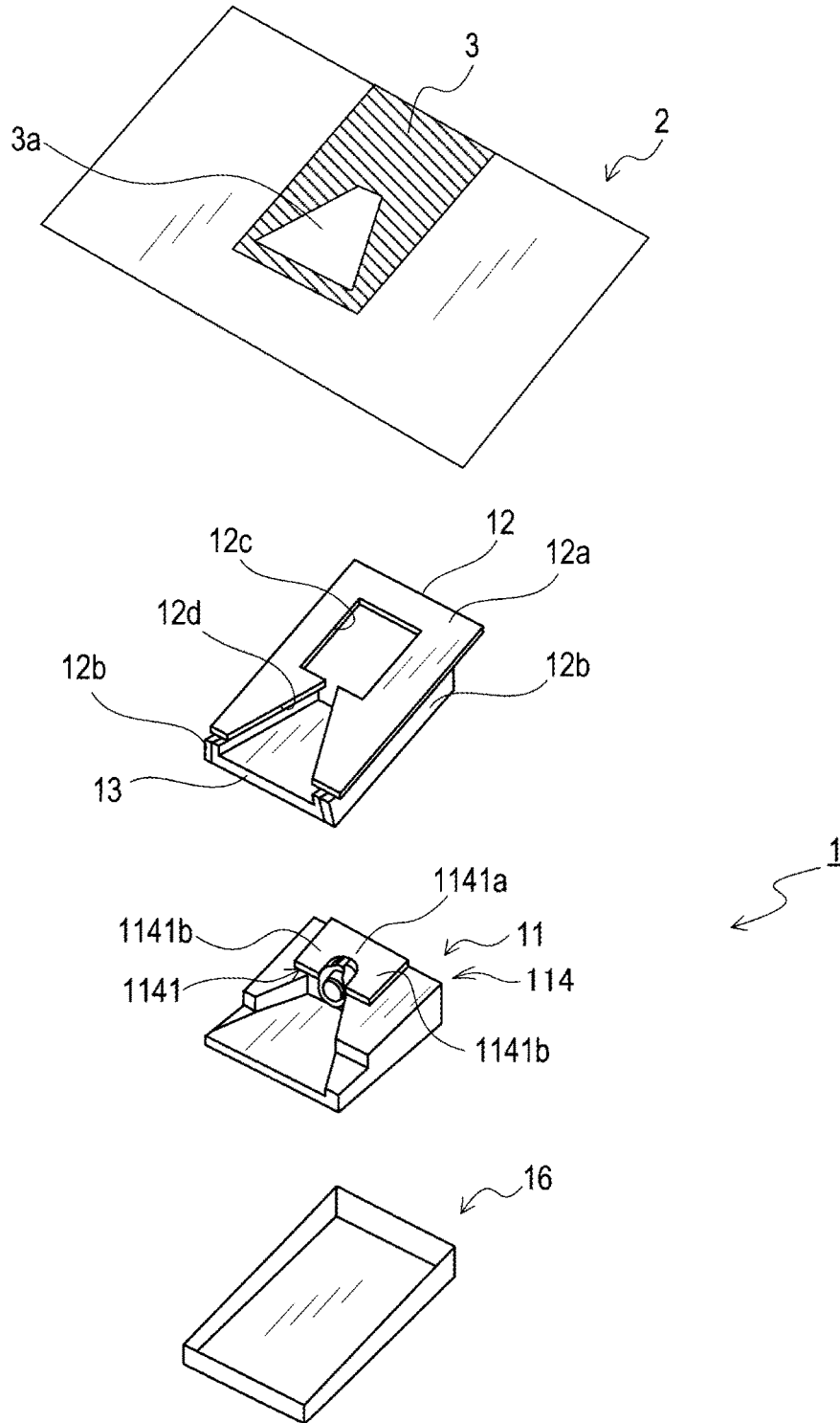

FIG. 4

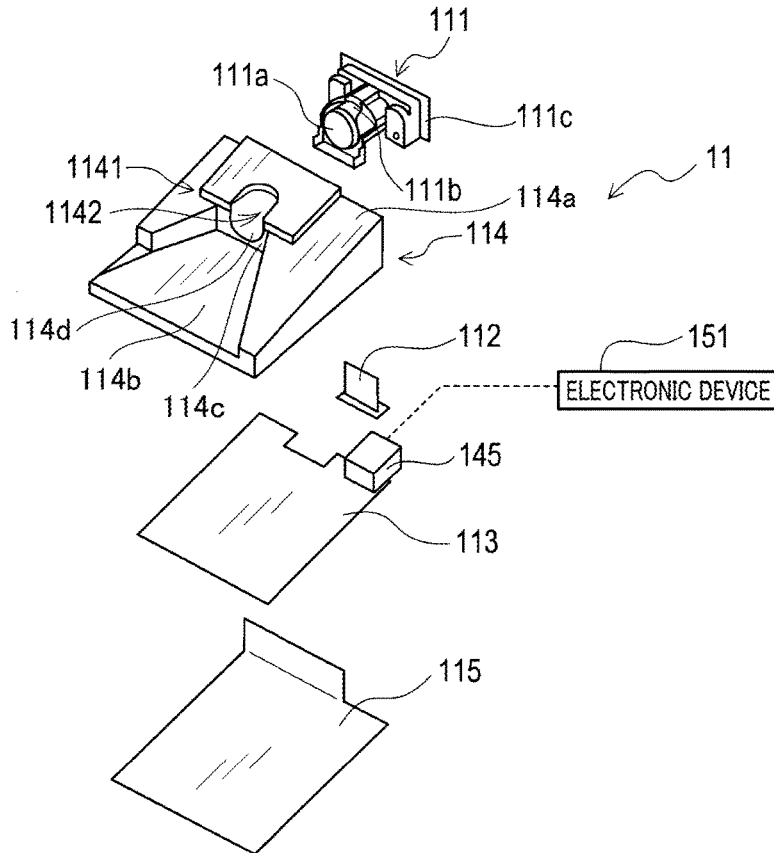

FIG. 5

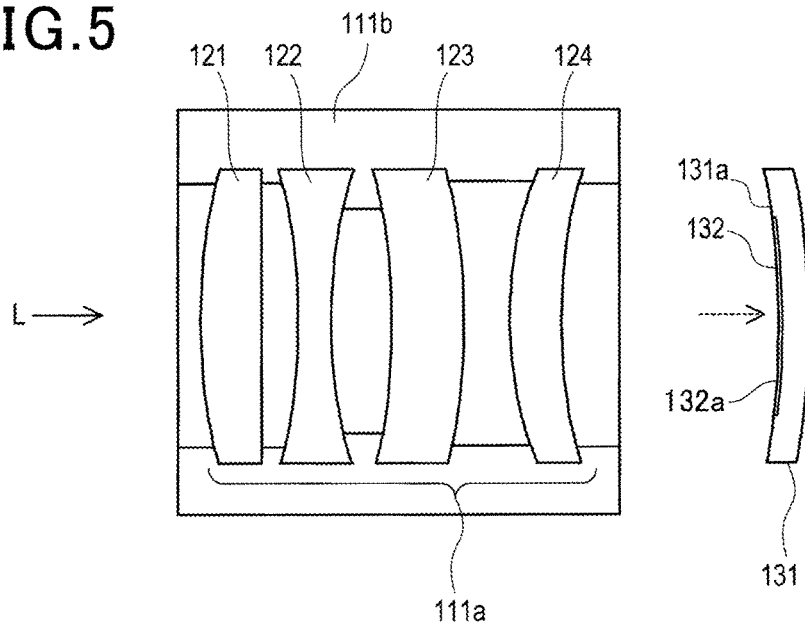

FIG. 6

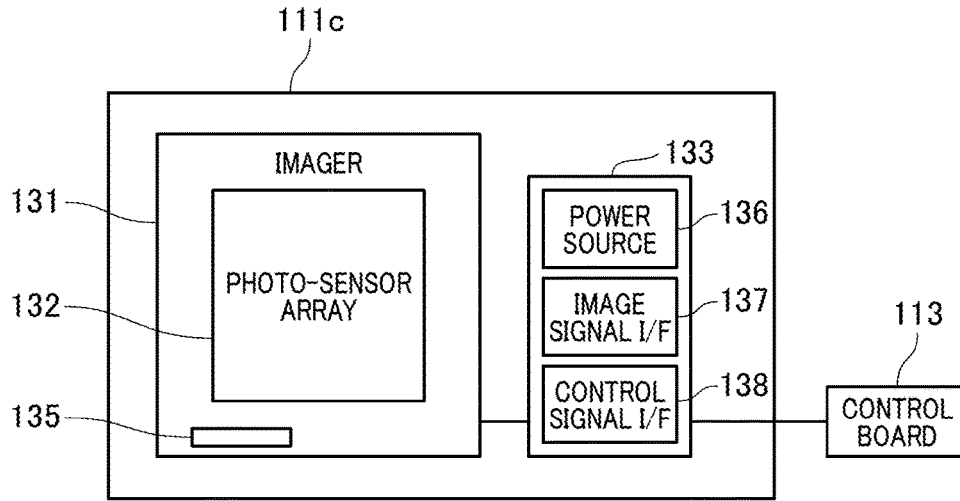

FIG. 7

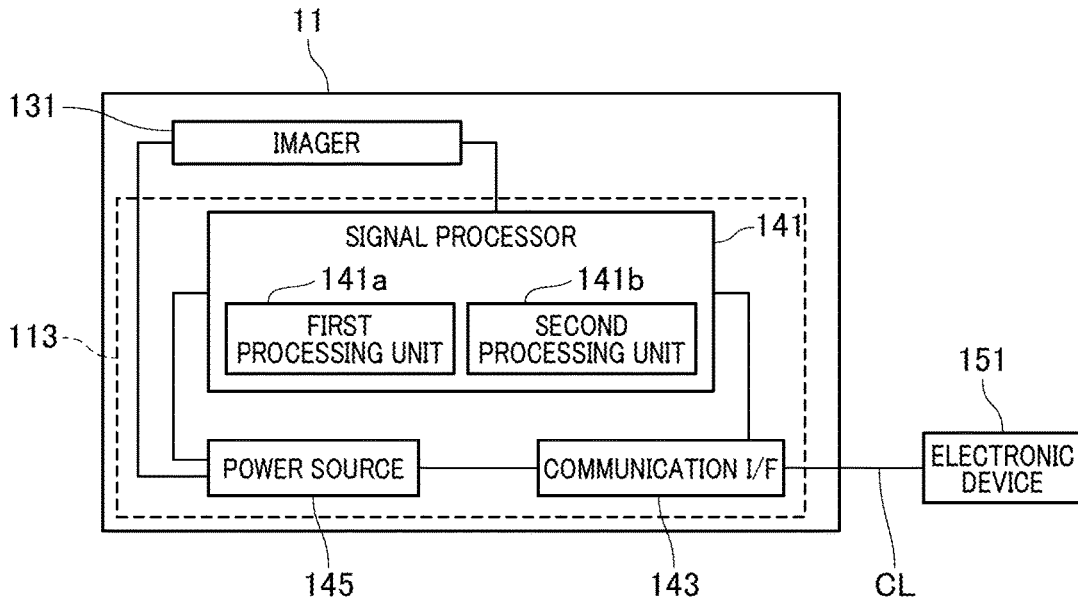

FIG. 8

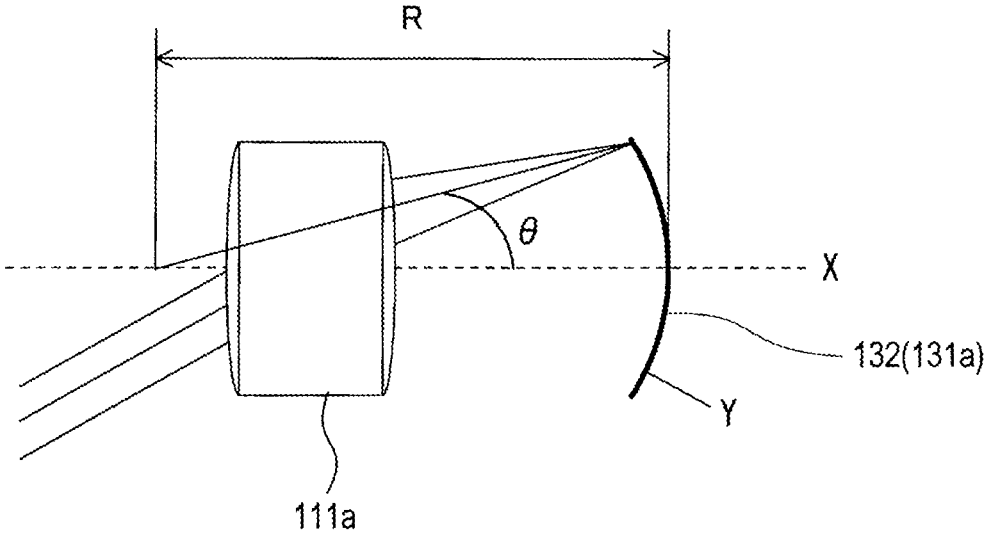

FIG. 9

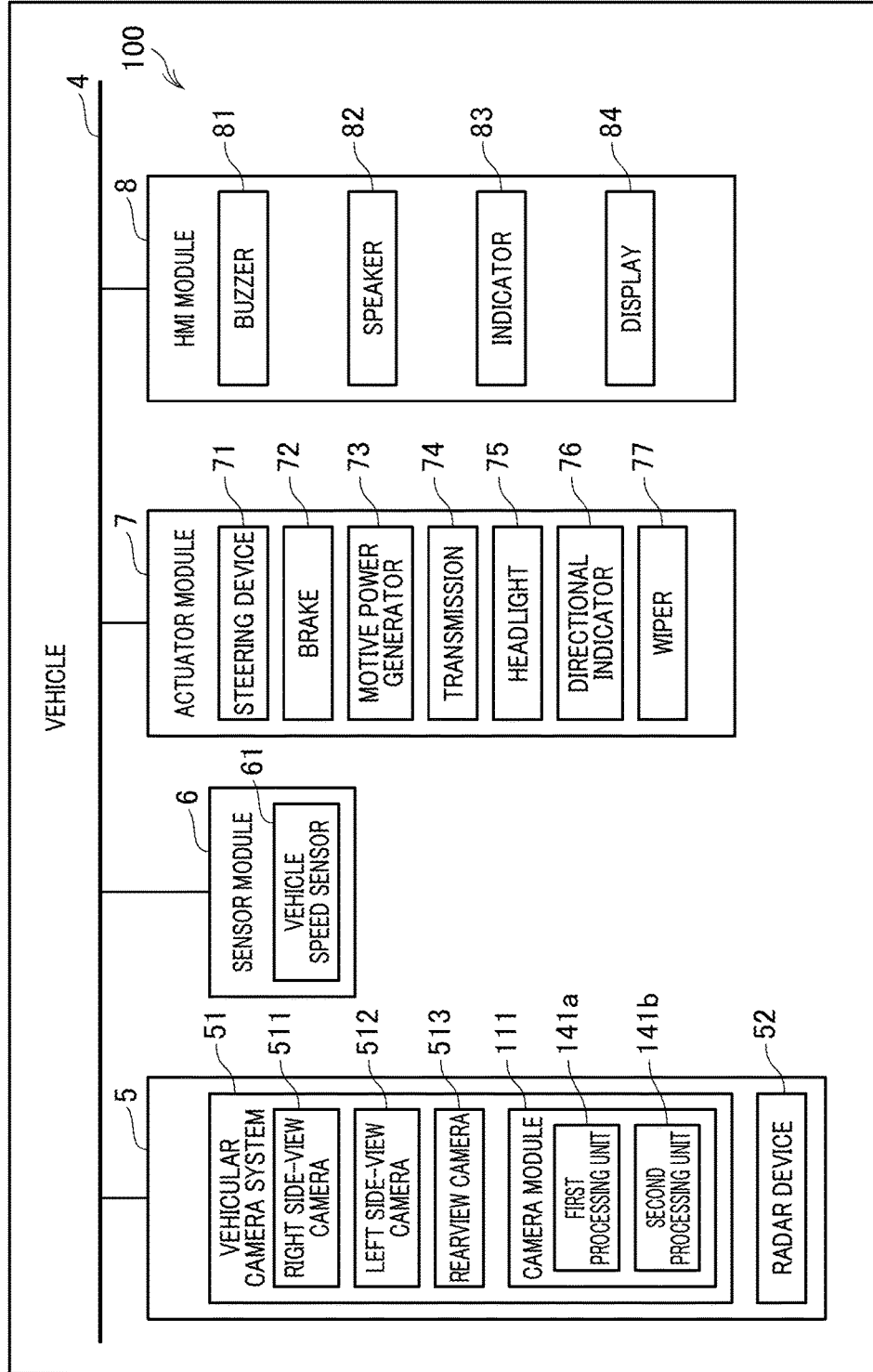

FIG. 10

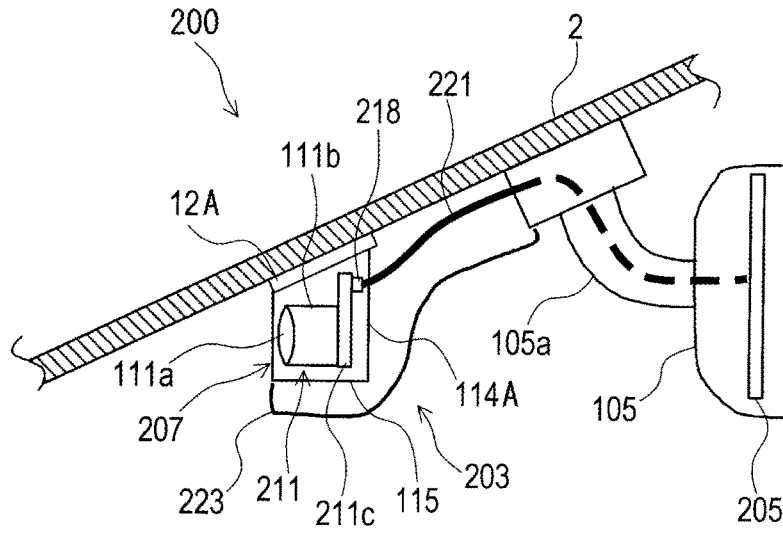

FIG. 11

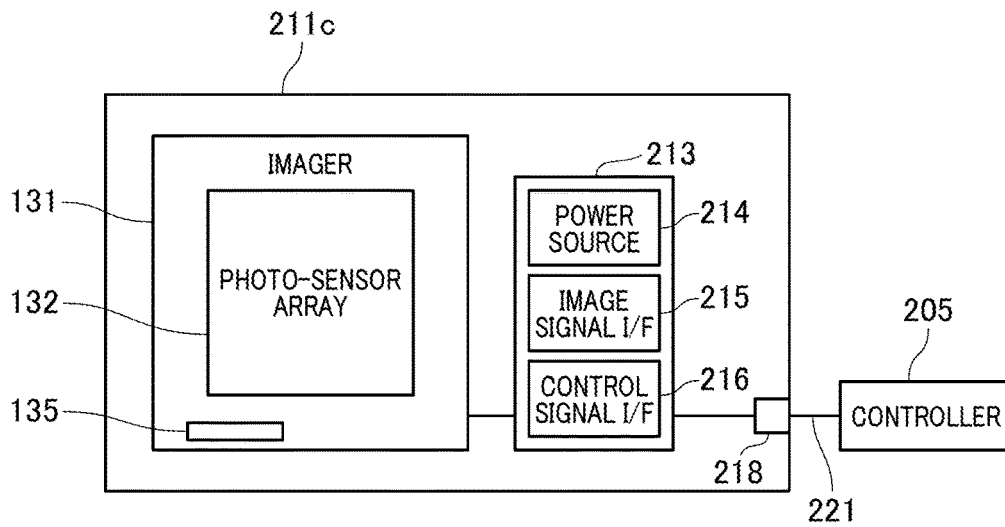
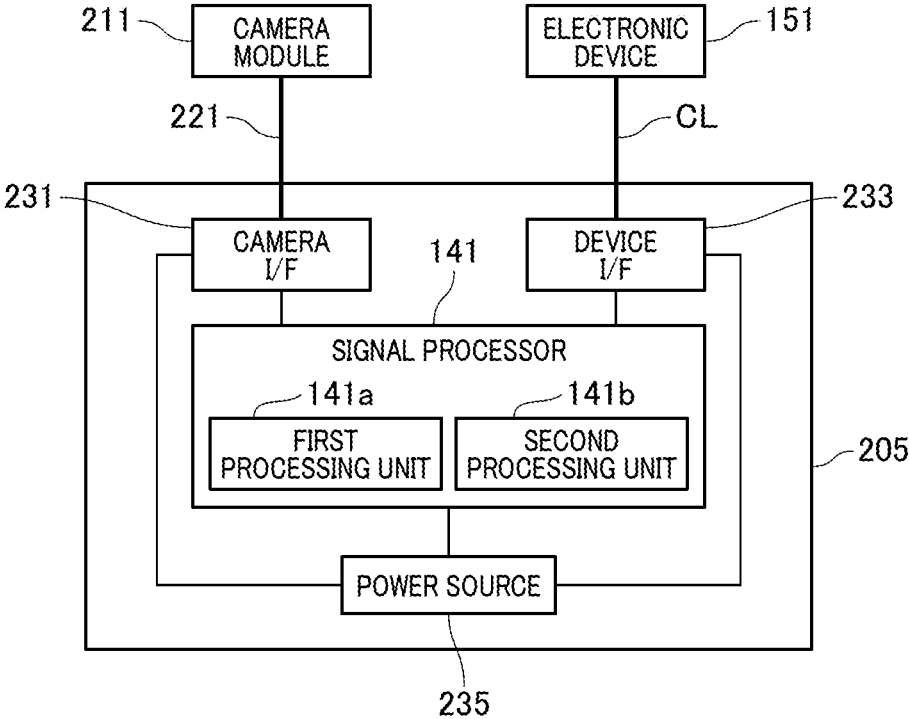



FIG. 12



## CAMERA APPARATUS AND IN-VEHICLE SYSTEM

### CROSS REFERENCE TO RELATED APPLICATION

**[0001]** This application is based on and claims the benefit of priority from Japanese Patent Applications No. 2015-131311 filed on Jun. 30, 2015, the disclosure of which is incorporated in its entirety herein by reference.

### TECHNICAL FIELD

**[0002]** The present disclosure relates to vehicular camera apparatuses either installable to or actually installed to vehicles, and to in-vehicle systems, which are installed to vehicles and each equipped with such a camera apparatus.

### BACKGROUND

**[0003]** To improve the safety of vehicles, camera apparatuses are installed to vehicles. Such a camera apparatus picks up, i.e. captures, images in front of the own vehicle. Then, a recognition apparatus installed in the own vehicle runs various application programs installed thereto using the captured images to recognize objects, such as pedestrians and other vehicles, in front of the own vehicle. Japanese Patent Application Publication No. 2014-164461 discloses methods and apparatuses for detecting pedestrians based on images acquired by such a camera apparatus.

### SUMMARY

**[0004]** Users of vehicles have requirements for camera apparatuses capable of picking up higher quality images to increase the accuracy of these application programs to a higher level.

**[0005]** In view these requirements, a first aspect of the present disclosure seeks to provide camera apparatuses installable to vehicles, which aim to address these requirements. In particular, a second aspect of the present disclosure seeks to provide such camera apparatuses installable to vehicles, each of which is capable of picking up higher-quality images. A third aspect of the present disclosure also seeks to provide in vehicle systems, each of which includes such a camera apparatus.

**[0006]** According to a first exemplary aspect of the present disclosure, there is provided a camera apparatus installable to a vehicle that includes a windshield and an electronic device installed thereto. The camera apparatus includes a camera module, a first processing unit, a second processing unit, a communication interface, a power source, a housing, a cover, and a mounting member.

**[0007]** The camera module has a predetermined field of view and configured to capture an image in front of the vehicle via a predetermined wiping area of the windshield of the vehicle. The first processing unit is configured to perform, based on the image captured by the camera module, at least part of a recognition task that recognizes situations in front of the vehicle. The second processing unit is configured to perform, based on a result of the recognition task performed by the first processing unit, at least part of a vehicle control task. The vehicle control task includes at least two of: a lane departure warning task for determining whether there is an unintentional departure of the vehicle from a lane on which the vehicle is running; a headlight

control task for controlling a headlight of the vehicle; and a task for preventing front collisions of the vehicle.

**[0008]** The communication interface enables the first and second processing units to communicate with the electronic device installed in the vehicle. The power source supplies electrical power to the camera module, the first processing unit, and the second processing unit. The housing is configured to house at least part of at least one of the camera module, the first processing unit, the second processing unit, the communication interface, and the power source. The cover is configured to cover at least part of at least one of the camera module, the first processing unit, the second processing unit, the communication interface, the power source, and the housing. The mounting member is configured to fixedly mount the camera module to the windshield of the vehicle such that the field of view of the camera module is directed in front of the vehicle

**[0009]** The camera module includes a lens unit including a plurality of lenses, and a barrel configured to house the lens unit. The camera module includes an imager having an imaging surface and arranged with respect to the lens unit such that light passing through the plurality of lenses of the lens unit forms an image on the imaging surface. The imager includes at least part of an exposure controller that controls an exposure of the imaging surface. The imaging surface is concavely curved with respect to the lens unit.

**[0010]** The above-configured camera apparatus according to the first exemplary aspect, which includes the camera module provided with the imager having the concavely curved imaging surface, enables higher-quality images in front of the vehicle to be captured. This enables the second processor of the camera apparatus to perform the vehicle control task with higher accuracy.

**[0011]** According to a second exemplary aspect of the present disclosure, there is provided an in-vehicle system including a camera apparatus installable to a vehicle, the vehicle including a windshield, a rearview mirror, and an electronic device installed thereto, and a controller installed in the rearview mirror. The camera apparatus includes a camera module, a first communication interface, a power source, a housing, a cover, and a mounting member.

**[0012]** The camera module has a predetermined field of view and configured to capture an image in front of the vehicle via a predetermined wiping area of the windshield of the vehicle. The first communication interface enables the camera module to communicate with the controller. The power source supplies electrical power to the camera module. The housing is configured to house at least part of at least one of the camera module, the first communication interface, and the power source. The cover is configured to cover at least part of at least one of the camera module, the first communication interface, the power source, and the housing. The mounting member is configured to fixedly mount the camera module to the windshield of the vehicle such that the field of view of the camera module is directed in front of the vehicle. The camera module includes a lens unit including a plurality of lenses, and a barrel configured to house the lens unit. The camera module includes an imager having an imaging surface and arranged with respect to the lens unit such that light passing through the plurality of lenses of the lens unit forms an image on the imaging surface. The imager includes at least part of an exposure

controller that controls an exposure of the imaging surface. The imaging surface is concavely curved with respect to the lens unit.

**[0013]** The controller includes a second communication interface, a first processing unit, a second processing unit, a third communication interface, and a power source. The second communication interface enables the controller to communicate with the camera module. The first processing unit is configured to perform, based on the image captured by the camera module, at least part of a recognition task that recognizes situations in front of the vehicle. The second processing unit is configured to perform, based on a result of the recognition task performed by the first processing unit, at least part of a vehicle control task. The vehicle control task includes at least two of: a lane departure warning task for determining whether there is an unintentional departure of the vehicle from a lane on which the vehicle is running, a headlight control task for controlling a headlight of the vehicle, and a task for preventing front collisions of the vehicle.

**[0014]** The third communication interface enables the first and second processing units to communicate with the electronic device installed in the vehicle. The power source supplies electrical power to the first processing unit and the second processing unit.

**[0015]** The above-configured camera apparatus according to the second exemplary aspect, which includes the camera module provided with the imager having the concavely curved imaging surface, enables higher-quality images in front of the vehicle to be captured. The above-configured camera apparatus according to the second exemplary aspect enables the camera module to be downsized, because the first and second processing units are provided in the controller installed in the rearview mirror.

**[0016]** According to a third exemplary aspect of the present disclosure, there is provided a camera apparatus installable to a vehicle that includes a windshield and an electronic device installed thereto. The camera apparatus includes a camera module, a communication interface, a power source, a housing, a cover, and a mounting member. The camera module has a predetermined field of view, and is configured to capture an image in front of the vehicle via a predetermined wiping area of the windshield of the vehicle. The communication interface enables the camera module to communicate with the electronic device installed in the vehicle. The power source supplies electrical power to the camera module. The housing is configured to house at least part of at least one of the camera module, the communication interface, and the power source. The cover is configured to cover at least part of at least one of the camera module, the communication interface, the power source, and the housing. The mounting member is configured to fixedly mount the camera module to the windshield of the vehicle such that the field of view of the camera module is directed in front of the vehicle. The camera module includes a lens unit comprising a plurality of lenses, and a barrel configured to house the lens unit. The camera module includes an imager having an imaging surface and arranged with respect to the lens unit such that light passing through the plurality of lenses of the lens unit forms an image on the imaging surface. The imager includes at least part of an exposure controller that controls an exposure of the imaging surface. The imaging surface is concavely curved with respect to the lens unit.

**[0017]** The above-configured camera apparatus according to the third exemplary aspect, which includes the camera module provided with the imager having the concavely curved imaging surface, enables higher-quality images in front of the vehicle to be captured.

**[0018]** The above and/or other features, and/or advantages of various aspects of the present disclosure will be further appreciated in view of the following description in conjunction with the accompanying drawings.

**[0019]** Various aspects of the present disclosure can include and/or exclude different features, and/or advantages where applicable. In addition, various aspects of the present disclosure can combine one or more feature of other embodiments where applicable. The descriptions of features, and/or advantages of particular embodiments should not be construed as limiting other embodiments or the claims.

#### BRIEF DESCRIPTION OF THE DRAWINGS

**[0020]** Other aspects of the present disclosure will become apparent from the following description of embodiments with reference to the accompanying drawings in which:

**[0021]** FIG. 1 is a perspective view schematically illustrating an example of the appearance of a vehicle in which a camera apparatus according to the first embodiment of the present disclosure is installed;

**[0022]** FIG. 2 is a cross sectional view schematically illustrating the camera apparatus mounted to the windshield of the vehicle;

**[0023]** FIG. 3 is an exploded perspective view schematically illustrating the camera apparatus illustrated in FIG. 2;

**[0024]** FIG. 4 is an exploded perspective view schematically illustrating an example of the structure of an image sensor of the camera apparatus illustrated in FIG. 3;

**[0025]** FIG. 5 is an enlarged view schematically illustrating a lens unit of a camera module of the image sensor illustrated in FIG. 4;

**[0026]** FIG. 6 is a block diagram schematically illustrating an example of the structure of an imaging board of the camera module illustrated in FIG. 4;

**[0027]** FIG. 7 is a block diagram schematically illustrating an example of the functional structure of the image sensor illustrated in FIG. 3;

**[0028]** FIG. 8 is an enlarged view schematically illustrating an example of the arrangement relationships between the lens unit and a photo-sensor array of the imager according to the first embodiment;

**[0029]** FIG. 9 is a block diagram schematically illustrating an example of the functional structure of an in-vehicle system according to the first embodiment;

**[0030]** FIG. 10 is a cross sectional view schematically illustrating an in-vehicle system including a camera apparatus and a controller, which are mounted to the windshield of the vehicle according to the second embodiment of the present disclosure;

**[0031]** FIG. 11 is a block diagram schematically illustrating an example of the structure of an imaging board of the camera apparatus illustrated in FIG. 10; and

**[0032]** FIG. 12 is a block diagram schematically illustrating an example of the functional structure of the controller illustrated in FIG. 10.

## DETAILED DESCRIPTION OF EMBODIMENT

[0033] The following describes the first and second embodiments of the present disclosure with reference to the accompanying drawings. The following omits or simplifies descriptions of like parts between the embodiments, to which identical or like reference characters are assigned, thus eliminating redundant descriptions. Various combinations of the embodiments can be carried out as long as there are no inconsistencies in each of the combinations. One or more components disclosed in one of the embodiments can be combined with one or more components disclosed in another one of the embodiments.

## First Embodiment

## Arrangement of Camera Apparatus

[0034] Referring to FIG. 1, a camera apparatus 1 is mounted to, for example, a windshield, i.e. a front windshield, 2 of a vehicle 101. The camera apparatus 1 constitutes an in-vehicle system, i.e. in-vehicle control system, 100 (see FIG. 9) installed in the vehicle 101 for controlling the operations of the vehicle 101.

[0035] In particular, the camera apparatus 1 is placed at the top center of the inner surface of the windshield 2 in the horizontal direction, i.e. the width direction of the vehicle 101. In other words, the camera apparatus 1 is located on the back of a predetermined wiping area 107 of the outer surface of the windshield 2 adjacent to a rearview mirror 105 of the vehicle 101. The wiping area 107 represents an area of the outer surface of the windshield 2 that a wiper (see reference numeral 77 in FIG. 9) wipes.

[0036] The camera apparatus 1 is designed as, for example, a monocular camera apparatus according to the first embodiment. The camera apparatus 1 has a predetermined field of view, i.e. a predetermined imaging area, which extends in the front direction of the vehicle 101 to have, for example, a sector shape in the vehicle width direction. FIG. 1 schematically illustrates a part of the field of view of the camera apparatus 1.

[0037] That is, the camera apparatus 1 picks up images of a region ahead of the vehicle 101 in the field of view through, for example, a part of the windshield 2; the part of the windshield 2 corresponds to the wiping area 107. The part of the windshield 2, which corresponds to the wiping area 107, will also be referred to simply as the wiping area 107 of the windshield 2. The following also describes the vehicle 101 as an own vehicle 101.

## Structure of Camera Apparatus

[0038] The following describes an example of the structure of the camera apparatus 1 with reference to FIGS. 2 to 7. Referring to FIGS. 2 and 3, the camera apparatus 1 includes, for example, an image sensor 11, a plate-like bracket 12, a hood 13, and a cover 16.

[0039] Referring to FIG. 4, the image sensor 11 includes, for example, a camera module 111, an electrical connection harness 112, a control board 113, a housing 114, and a bottom cover 115.

[0040] The camera module 111 aims to capture images in front of the own vehicle 101 through the wiping area 107 of the windshield 2. Specifically, the camera module 111 is comprised of a lens unit 111a, a lens barrel 111b, and an imaging board 111c

[0041] Referring to FIG. 5, the lens unit 111a includes four lenses 121, 122, 123, and 124 combined to each other as an example of the assembly of a plurality of lenses. The lenses 121 to 124 are coaxially aligned with given intervals therebetween in this order from the front side to the rear side of the own vehicle 101. The lens barrel 111b has a substantially tubular shape, and houses the assembly of the lenses 121 to 124. Specifically, the assembly of the lenses 121 to 124 is coaxially installed in the lens barrel 111b while the outer peripheries of the lenses 121 to 124 are supported by the lens barrel 111b. That is, an optical axis of the lens barrel 111b coincides with an optical axis of the assembly of the lenses 121 to 124.

[0042] For example, the first embodiment uses a plano-convex lens as the lens 121, a biconcave lens as the lens 122, a first meniscus lens as the lens 123, and a second meniscus lens as the lens 124. The plano-convex lens 121 has a convex surface on a first major side directed in front of the own vehicle 101, and a plane surface on a second major side opposite to the first major side. The biconcave lens 122 has a concave surface on each major side; one of the major sides of the biconcave lens 122 faces the plano-convex lens 121.

[0043] The first meniscus lens 123 has a concave surface on a first major side, and a convex surface on a second major side opposite to the first major side; the concave surface of the first meniscus lens 123 faces the other of the major sides of the biconcave lens 122.

[0044] The second meniscus lens 124 has a convex surface on a first major side, and a concave surface on a second major side opposite to the first major side; the convex surface of the second meniscus lens 124 faces the convex surface of the first meniscus lens 123, and the concave surface thereof faces the imaging board 111c.

[0045] Note that the lens unit 111a can be comprised of at least two lenses.

[0046] The electrical connection harness 112 electrically connects electrical components of the imaging board 111c described later and the control board 113.

[0047] The imaging board 111c includes an imager 131 and a control circuit 133. The imaging board 111c has one major surface, i.e. a front surface, on which the imager 131 (see FIGS. 5 and 6) is mounted. The imager 131 has an outer major surface serving as a light receiving surface 131a, and includes a photo-sensor array 132 mounted on the light receiving surface 131a. The photo-sensor array 132 is comprised of photo sensors, i.e. semiconductor photodiodes, two-dimensionally arranged in rows and columns, or one-dimensionally arranged in a row. Each of the photo sensors has a light receiving area, so that the photo-sensor array 132 has an imaging surface 132a composed of the light receiving areas of the photo sensors.

[0048] The imaging board 111c is mounted to the lens barrel 111b such that the center of the photo-sensor array 132 is disposed to be coaxial to the lenses 121 to 124. This enables light L incident to the lens unit 111a, i.e. the lens 121, to pass through the lenses 121 to 124 so as to be formed as an image onto the photo-sensor array 132, thus picking up the image.

[0049] The photo-sensor array 132 converts the picked-up image based on the incident light L into an image signal including pixels measured by the photo sensors, and outputs the image signal based on the picked-up image to the control circuit 133. Note that the assembly of the lenses 121 to 124 is operative to form an image on the photo-sensor array 132

while reducing various aberrations in the formed image. In other words, the number and configurations of lenses constituting the lens unit **111a** are determined to, for example, form an image on the photo-sensor array **132** while reducing aberrations in the formed image.

**[0050]** In particular, the imager **131** is configured such that the light receiving surface **131a** and the photo-sensor array **132** are concavely curved with respect to the lens unit **111a**. In other words, the imager **131** is configured such that the imaging surface **132a** of the photo-sensor array **132**, which is included in the light receiving surface **131a**, is concavely curved with respect to the lens unit **111a**.

**[0051]** The first embodiment describes the detailed structure of the imager **131** later.

**[0052]** Referring to FIG. 6, the imager **131** includes, in addition to the photo-sensor array **132**, an exposure controller **135** connected to the photo-sensor array **132**. The control circuit **133** includes a power source **136**, an image-signal interface, referred to an image-signal I/F, **137**, and a control-signal interface, referred to a control-signal I/F, **138**.

**[0053]** The exposure controller **135** is capable of controlling the exposure of the imaging surface **132a**, i.e. the photo-sensor array **132**. Specifically, the exposure controller **135** receives the image signal output from the imager **131**, and measures, for example, the intensities of all the pixels of the picked-up image. Then, the exposure controller **135** adjusts the exposure, i.e. the length of exposure or the exposure time, of the photo-sensor array **132** based on the measured intensities of all the pixels of the picked-up image.

**[0054]** The power source **136** supplies operating power to each of the electrical components constituting the imaging board **111c**.

**[0055]** The control circuit **133** is connected to the control board **113**. The image-signal I/F **137** receives the image signal output from the imager **131**, and outputs the image signal to the control board **113**.

**[0056]** The control-signal I/F **138** receives control signals sent from the control board **113** described hereinafter; the control signals are operative to control how the imager **131** operates. That is, the control-signal I/F **138** enables the control signals sent from the control board **113** to control the photo-sensor array **132** and the exposure controller **135** of the imager **131**.

**[0057]** The following describes electrical functions of the image sensor **11** with reference to FIG. 7. The control board **113** of the image sensor **11** includes a signal processor **141**, a communication interface, referred to as a communication I/F, **143**, and a power source **145**.

**[0058]** The signal processor **141** essentially includes, for example, a CPU, a memory, such as a ROM and/or a RAM, an I/O, and a bus connecting between the CPU, memory, and I/O. The signal processor **141** is connected to the imager **131**, the power source **145**, and the communication I/F **143**. The signal processor **141** functionally includes a first processing unit **141a** and a second processing unit **141b**. In other words, the signal processor **141** serves as both the first and second processing units **141a** and **141b**.

**[0059]** The first processing unit **141a** performs, based on one or more image captured by the camera module **111**, a recognition task that recognizes the situations around the own vehicle **101**.

**[0060]** The second processing unit **141b**, which is operatively connected to the first processing unit **141a**, performs, based on the recognized situations around the own vehicle

**101**, a vehicle control task that controls at least one of the actuators or other similar devices installed in the own vehicle **101**. The following describes some targets recognized by the recognition task later, and describes the details of the vehicle control task later.

**[0061]** The communication I/F **143** serves as an interface that enables each of the first and second processing units **141a** and **141b** to communicate with electronic devices **151** installed in the own vehicle **101**. For example, the communication I/F **143** includes connectors and an electric or electronic circuit when the image sensor **11** is connected to the electronic devices **151** via communication lines CL. The connectors are individually connected to the communication lines, and the electronic circuit establishes communications between the electronic devices **151** and each of the first and second processing units **141a** and **141b**. The following defines an interface as a module including at least one connector and an electronic circuit that can establish communications with one or more components connected to the at least one connector.

**[0062]** The power source **145** is configured to receive electrical power supplied from an accessory power source and/or a battery installed in the own vehicle **101**. Then, the power source **145** supplies electrical power to the camera module **111** including the imager **131**, and the control board **113** including the signal processor **141**.

**[0063]** Referring to FIG. 4, the housing **114** has a substantially rectangular parallelepiped shape with a top wall **114a**, an opening bottom wall, and an inner hollow container space. The housing **114** covers the assembly of the camera module **111** and the control board **113** from above to house the assembly accordingly.

**[0064]** The bottom cover **115** is disposed at a lower side of the control board **113** to close the opening bottom of the housing **114**. That is, the camera module **111**, the control board **113**, the power source **145**, and the electrical connection harness **112** are contained in the assembly of the housing **114** and the bottom cover **115**, so that the camera apparatus **1** is constructed.

**[0065]** The top wall **114a** of the housing **114** is inclined toward the front side of the own vehicle **101**. A rectangular part of a rear half portion of the top wall **114a** is protruded upward to form a protruded wall **1141**. The protruded wall **1141** serves as an attachment wall to, for example, the windshield **2** of the own vehicle **101** (see FIG. 2). Hereinafter, the protruded wall **1141** will be referred to as an attachment wall **1141**.

**[0066]** The attachment wall **1141** has a substantially U-shaped concave recess **1141a** formed in a front surface thereof to a substantially center of the attachment wall **1141b**, so that a top surface of the attachment wall **1141** has a substantially concave shape. In other words, the attachment wall **1141** is comprised of a left-hand end and a right-hand end that sandwiches the U-shaped concave recess **1141a**.

**[0067]** The housing **114** has a trapezoidal concave recess **114b** formed in the top surface **114a** downward. The trapezoidal concave recess **114b** has a vertical wall **114c** located close to the front surface of the attachment wall **1141**. The vertical wall **114c** has a top surface intersecting with the front surface of the attachment wall **1141**, so that the vertical wall **114c** and the attachment wall **1141** constitute a downward stepped portion. The vertical wall **114c** has a concave recess **114d** formed in the top surface of the vertical wall **114c** and communicating with the U-shaped concave recess

**1141a.** The U-shaped concave recess **1141a** and the concave recess **114d** constitute an opening **1142** for exposing the lens unit **111a** and the lens barrel **111b** to the front direction of the own vehicle **101** and to the windshield **2**.

**[0068]** When the housing **114** is attached to the windshield **2** with the bracket **12** in a method described later so as to be fixed to the windshield **2**, the attachment wall **1141** is located to be closer to the windshield **2** than the camera module **111** is.

**[0069]** Referring to FIGS. **2** and **3**, the bracket **12** is configured to fixedly mount the housing **114** of the image sensor **11** to the windshield **2**. The bracket **12**, which is made of, for example, resin or metal, includes a rectangular plate-like portion **12a** disposed along the windshield **2**; the plate-like portion **12a** has a first surface facing the windshield **2** and a second surface opposite to the first surface. The bracket **12** also includes a pair of sidewalls **12b** each mounted perpendicularly to a corresponding one of the longitudinal edges of the second surface of the plate-like portion.

**[0070]** The plate-like portion **12a** has a substantially rectangular opening **12c** formed therethrough. The plate-like portion **12a** has a first lateral end corresponding to the rear side of the own vehicle **101** and a second lateral end opposite to the first lateral end and corresponding to the front side of the own vehicle **101**. The plate-like portion **12a** also has a substantially trapezoidal recess, in other words, notch, **12d** extending from the second lateral end to the opening and communicating with the opening **12c**. The opening **12a** and the trapezoidal recess **12d** result in the plate-like portion **12a** having a substantially U shape.

**[0071]** The sidewalls **12b** are disposed at both sides of the opening **12c** and the trapezoidal recess **12d**. The above bracket **12** is configured such that the hood **13** is fitted in the trapezoidal recess **12d** between the sidewalls **12b**.

**[0072]** Specifically, the top surface **12a** of the bracket **12** is fixedly mounted, for example, adhered, to the inner surface of the windshield **2**. The housing **114** is mounted to the bracket **12** fixedly mounted on the inner surface of the windshield **2** such that the attachment wall **1141** of the housing **114** faces the windshield **2**.

**[0073]** While the housing **114** is mounted to the windshield **2** via the bracket **12**, the opening **12c** of the bracket **12** enables the housing **114** to face the windshield **2**. The situation where the housing **114** faces the windshield **2** means that the housing **114** fronts the windshield **2** without any intervening members therebetween.

**[0074]** While the housing **114** is mounted to the windshield **2** via the bracket **12**, the trapezoidal recess **12d** is located in front of the camera module **111**. The trapezoidal recess **12d** has a substantially trapezoidal shape so as to become broader in width toward the front side of the camera module **111**; the recess **12d** is in conformance with a horizontally sector imaging region, i.e. a horizontal view-angle region, of the lens unit **111a** of the camera module **111** extending in front of the lens unit **111a**. This enables the field of view of the lens unit **111a**, i.e. the camera module **111**, to be sufficiently ensured.

**[0075]** As described above, the bracket **12** is configured to mount the camera module **111** to the windshield **2** such that the field of view of the camera module **111** is provided in front of the own vehicle **101**. The bracket **12** serves as, for example, an example of mount members in the present disclosure.

**[0076]** The hood **13** is made of, for example, a resin, and has a substantially trapezoidal bottom surface, and a pair of opposing side surfaces perpendicular to respective oblique sides of the trapezoidal bottom surface. The hood **13** is mounted between the sidewalls **12b** of the bracket **12** with the trapezoidal bottom surface facing the recess **12d**. Specifically, when the housing **114** is attached to the bracket **12**, the hood **13** is mounted on or above the bottom surface of the trapezoidal concave recess **114b** such that the bottom surface and the opposing side surfaces of the hood **113** surround the substantially sector imaging region (horizontal view-angle region). The imaging region substantially corresponds to the field of view of the lens assembly **111a**, i.e. the camera module **111**. In particular, the hood **113** is mounted to the trapezoidal concave recess **114b** such that the bottom surface of the hood **113** is located to be lower than the lens barrel **111b** of the camera module **111**.

**[0077]** The above arrangement of the hood **113** reduces the possibility that objects located outside of the sector imaging region of the camera module **111** are captured by the camera module **111**.

**[0078]** For example, the bracket **12** according to the first embodiment is adhered to the windshield **2**. In particular, the bracket **12** is adhered to a black ceramic sheet **3**. Thereafter, the black ceramic sheet **3** is closely contacted on the inner surface of the front windshield **102**. The black ceramic sheet **3** has a transparent opening **3a** facing the trapezoidal recess **12d** of the bracket **12**. The transparent opening **3a** prevents the black ceramic sheet **3** from blocking the sector imaging region of the camera module **111**.

**[0079]** The cover **16** has a substantially rectangular parallelepiped shape with an opening top wall, a bottom wall, and an inner hollow container space. The cover **16** covers the image sensor **11**, the bracket **12**, and the hood **13** from below to reduce the possibility of the bracket **12** and hood **13** being visible from the inside of the own vehicle **101**.

#### Structure of Imager

**[0080]** The imager **131** of the imaging board **111c** has the light receiving surface **131a** that has a concavely curved shape with respect to the lens unit **111a**. In other words, the imager **131** is configured as a curved imager, i.e. a curved image sensor. The following describes the shape of the imager **131** in accordance with FIG. **8**. For example, FIG. **8** schematically illustrates the lens unit **111a** as a single biconvex lens, and schematically illustrates only the photo-sensor array **132** mounted on the light-receiving surface **131a** as the imager **131**.

**[0081]** For example, each of the light receiving surface **131a** and the photo-sensor array **132**, i.e. its imaging surface **132a**, has a radius  $R$  of curvature at any point thereon. The photo-sensor array **132** of the imager **131** is arranged with respect to the lens unit **111a** such that light passing through the lens unit **111a** forms an image on the imaging surface **132a** of the photo-sensor array **132**. More specifically, the lens unit **111a** and the photo-sensor array **132** are arranged such that, if the angle formed between a principal ray from a light source, i.e. a target object, and the optical axis  $X$  becomes zero degrees, the light collection efficiency of the photo-sensor array **132** with respect to light rays from the corresponding light source becomes the maximum efficiency. Note that a principal ray is defined as a selected ray in rays from a given point, such as a light source; the

selected ray passes through the center of a diaphragm or an aperture of the lens unit **111a** comprised of the lenses **121** to **124**.

[0082] The condition required for the edge portion of the imaging surface **132a** of the photo-sensor array **132** to have sensitivity as high as the center portion thereof is defined by the following equation (1):

$$R=Y/(2\theta) \quad (1)$$

[0083] Where R represents the radius of curvature at any point on the imaging surface **132a**, Y represents the length of an arc connecting diagonal points of one pair of the imaging surface **132a**, and  $\theta$  represents an angle in radian formed between a principal ray incident to the imaging surface **132a** and an optical axis X of the lens unit **11a**.

[0084] The camera module **111**, which is mounted to the top portion of the inner surface of the windshield **2** in the own vehicle **101**, results in an angle  $\theta$  formed between a principal ray from a light source, which is incident to the imaging surface **132a**, and the optical axis X being within the range defined by the following equation (2):

$$\pi/36 < \theta < \pi/6 \quad (2)$$

[0085] Note that the range of the angle  $\theta$  defined by the equation (2) is, for example, empirically derived from many product designs carried out by the inventors.

[0086] The equations (1) and (2) lead to the limitation that the radius R of curvature at any point on the imaging surface **132a** is preferably set within the range defined by the following equation (3) to meet the equations (1) and (2):

$$3/\pi < R/Y < 18/\pi \quad (3)$$

[0087] Determining the structure of the photo-sensor array **132** to meet the equation (3) restricts an incident angle from a light source to the imaging surface **132a** of the photo-sensor array **132** from increasing, thus reducing the level of peripheral shading of the photo-sensor array **132a**.

[0088] Note that Y represents the length of an arc along any diameter of the imaging surface **132a** if the imaging surface **132a** has a circular shape.

#### Electrical Structure of Vehicle Control System Using Camera Apparatus

[0089] The following describes an example of the electrical structure of the in-vehicle system **100** including the camera apparatus **1** with reference to FIG. 9. FIG. 9 schematically illustrates an example of the in-vehicle system **100** as a part of the total control system installed in the own vehicle **101**.

[0090] Referring to FIG. 9, the in-vehicle system **100** includes a monitor module **5**, a sensor module **6**, an actuator module **7**, a Human Machine Interface (HMI) module **8**, and a common bus **4** through which the modules **5** to **8** are communicable.

[0091] The monitor module **5** includes an in-vehicle camera system **51** and a radar device **52**, which serve as devices for monitoring the environmental situations around the own vehicle **101**.

[0092] For example, the in-vehicle camera system **51** includes, in addition to the camera module **111**, i.e. the camera apparatus **1**, a right side-view camera **511**, a left side-view camera **512**, and a rearview camera **513**. The right side-view camera **511** is for example attached to the right side-view mirror of the own vehicle **101** for picking up

images of right-hand views from the own vehicle **101**. The left side-view camera **512** is for example attached to the left side-view mirror for picking up images of left-hand views from the own vehicle **101**. The rearview camera **513** is for example attached to the rear portion, such as the rear gate, of the own vehicle **101** for picking up rear views from the own vehicle **101**.

[0093] The radar device **52** is operative to transmit probing waves, such as radar waves within a millimeter wave-band or laser waves, to a predetermined scan region, and receive echoes from at least one object based on the transmitted probing waves. Based on the received echoes, the radar device **52** is operative to generate object information including at least

[0094] (1) The distance of the at least one object relative to the own vehicle **101**

[0095] (2) The relative speed of the at least one object with respect to the own vehicle **101** if the at least one object is a moving object

[0096] (3) The lateral position of the at least one object relative to the own vehicle **101** in the lateral direction of the own vehicle **101**.

[0097] The radar device **52** is also operative to output the object information to the first processing unit **141a** of the signal processor **141**.

[0098] The radar device **52** can include a sonar for transmitting ultrasonic waves as the probing waves and for receiving echoes based on the ultrasonic waves from at least one object.

[0099] The sensor module **6** is operative to measure the operating conditions, i.e. travelling conditions, of the own vehicle **101** or devices installed in the own vehicle **101**. For example, the sensor module **6** includes a vehicle speed sensor **61** operative to measure the speed, i.e. the travelling speed, of the own vehicle **101**, and output, to the bus **4**, a sensor signal indicative of the measured speed of the own vehicle **101**. The sensor signal sent from the vehicle speed sensor **61** is output to the signal processor **141** via the bus **4**. The sensor signal can be input to ECUs installed in the own vehicle **101**, such as an engine ECU. The ECUs can be operative to execute various tasks based on the input sensor signal, and output the executed results of the various tasks to the bus **4**. At that time, the signal processor **141** can receive the executed results of the various tasks via the bus **4**.

[0100] The actuator module **7** includes actuators installed in the own vehicle **101**; the actuators are controllable by, for example, the signal processor **141**.

[0101] The actuators to be controlled by the signal processor **141** include at least three types of actuators:

[0102] The first type of actuators are used for controlling a body system of the own vehicle **101**.

[0103] The second type of actuators are used for controlling a power-train system of the own vehicle **101**.

[0104] The third type of actuators are used for controlling a chassis system of the own vehicle **101**.

[0105] For example, the actuators, in other words, the target devices, to be controlled by the signal processor **141**, include a steering device **71**, a brake **72**, a motive power generator **73**, an automatic transmission **74**, headlights **75**, directional indicators **76**, and wipers **77**.

[0106] The steering device **71** is operative to assist the driver's steering of the steering wheel of the own vehicle **101**. The brake **72** is operative to slow down the own vehicle

**101.** The motive power generator **73** is comprised of, for example, an internal combustion engine and/or a motor, and is operative to generate motive power for travelling the own vehicle **101**.

**[0107]** The automatic transmission, referred to simply as a transmission **74**, is operative to convert a rotational speed and torque as the motive power generated by the motive power generator **73** into an adjusted rotational speed and adjusted torque, and supply the adjusted rotational speed and adjusted torque to driving wheels of the own vehicle **101**.

**[0108]** The headlights **75** are operative to light up the road on which the own vehicle **101** is travelling. Each of the directional indicators **76** is operative to flash when the own vehicle **101** is about to turn in a corresponding direction, i.e. right or left, or to make a corresponding lane change. The wipers **77** are operative to clean the respective front windshield **2** and rear windshield from rain, snow, or other moisture.

**[0109]** The HMI module **8** is operative to provide interfaces between occupants in the own vehicle **101** and the in-vehicle system **100**. For example, the HMI module **8** includes a buzzer **81**, a speaker **82**, at least one indicator **83**, at least one display **84**, and actuators of the respective devices **81** to **84** installed in the own vehicle **101**.

**[0110]** The buzzer **81** is operative to output a warning sound, and the speaker **82** is operative to output audible information. The at least one indicator **83** is operative to generate a light signal, and the at least one display **84** includes a navigation display and/or a head-up display installed in a center console of the own vehicle **101**.

**[0111]** In addition, the HMI module **8** can include at least one vibration device and at least one reaction force generator (not shown). The at least one vibration device is comprised of a motor for generating vibrations of at least one of the steering wheel of the own vehicle **101** and the seats of the own vehicle **101**. The at least one reaction force generator is operative to generate reaction force to be supplied to at least one of the steering wheel of the own vehicle **101** and a brake pedal of the own vehicle **101**.

**[0112]** Specifically, the HMI module **8** is operative to activate at least one of these devices included therein to offer information to occupants of the own vehicle **101**.

**[0113]** The HMI module **8** can include an adjusting unit that allows an occupant to input a desired level of recognition for a recognition task described later and/or a timing to start a determining task described later, thus transferring information from an occupant to the own vehicle **101**.

**[0114]** The first processing unit **141a** of the signal processor **141** is operative to perform a recognition task to recognize the environmental conditions around the own vehicle **101**, in particular in front of the own vehicle **101**, based on images picked up by the in-vehicle camera system **51** and/or the object information measured by and sent from the radar device **52**.

**[0115]** The recognition task based on images captured by the camera module **111** of the in-vehicle camera system **51** except for the object information measured by the radar device **52** will be referred to as a first recognition task. The recognition task based on the object information measured by the radar device **52** will be referred to as a second recognition task.

**[0116]** The first processing unit **141a** successively, i.e. cyclically, captures images successively picked up by the

camera module **111**, and performs, based on the captured images, a recognition task to recognize at least one of

**[0117]** (1) The lanes ahead of the own vehicle **101** including a lane on which the own vehicle **101** is currently travelling, which will be referred to as lane information

**[0118]** (2) The shape of a road ahead of the travelling own vehicle **101**, which will be referred to as road shape information

**[0119]** (3) The conditions of a road surface ahead of the travelling own vehicle **101**, which will be referred to as road surface information

**[0120]** (4) One or more light sources ahead of the own vehicle **101**, which will be referred to as light source information

**[0121]** (5) One or more preceding vehicles including vehicles travelling ahead of the own vehicle **101**, which will be referred to as preceding-vehicle information

**[0122]** (6) One or more oncoming vehicles, which will be referred to as oncoming-vehicle information

**[0123]** (7) One or more stopped vehicles around the own vehicle **101**, which will be referred to as stopped-vehicle information

**[0124]** (8) One or more preceding pedestrians around the own vehicle **101**, which will be referred to as preceding-pedestrian information

**[0125]** (9) One or more oncoming pedestrians around the own vehicle **101**, which will be referred to as oncoming-pedestrian information

**[0126]** (10) One or more stopping persons around the own vehicle **101**, which will be referred to as stopped-person information

**[0127]** (11) One or more motor cycles around the own vehicle **101**, which will be referred to as motor-cycle information

**[0128]** (12) One or more bicycles around the own vehicle **101**, which will be referred to as bicycle information

**[0129]** (13) One or more obstacles around the own vehicle **101**, which will be referred to as obstacle information

**[0130]** (14) One or more roadside objects around the own vehicle **101**, which will be referred to as roadside-object information

**[0131]** (15) One or more traffic signs around the own vehicle **101**, which will be referred to as traffic-sign information

**[0132]** (16) One or more traffic signals around the own vehicle **101**, which will be referred to as traffic-signal information

**[0133]** (17) One or more traffic markings around the own vehicle **101**, which will be referred to as traffic-marking information

**[0134]** (18) One or more advertising signs around the own vehicle **101**, which will be referred to as advertising-sign information

**[0135]** (19) A tunnel through which the own vehicle **101** is going to go, which will be referred to as tunnel information

**[0136]** (20) One or more emergency parking bays, which will be referred to as emergency-bay information

**[0137]** (21) Something that blocks the view of the camera module **111**, which will be referred to as camera-view blocking information

**[0138]** (22) Meteorological environments around the own vehicle **101**, which will be referred to as meteorological-environment information



[0139] (23) Building structures around the own vehicle **101**, which will be referred to as building structure information.

[0140] For example, the first processing unit **141a** recognizes the lane markers ahead of the own vehicle **101** based on, for example, the captured images, thus recognizing the lanes ahead of the own vehicle **101** including a lane on which the own vehicle **101** is currently travelling based on the recognized lane markers.

[0141] The shape of a road represents the curvature or slope of the road, and the conditions of a road include the degree of reflection on the road surface particularly if it is raining or snowing.

[0142] The light sources include a tail lamp of a preceding vehicle and a head lamp of an oncoming vehicle, and can be recognized by the light-source recognition task **40b** set forth above.

[0143] The preceding pedestrians are pedestrians walking, ahead of the own vehicle **101**, in a direction identical to the travelling direction of the own vehicle **101**, and the oncoming pedestrians are pedestrians walking, ahead of the own vehicle **101**, in a direction opposite to the travelling direction of the own vehicle **101**. The stopping persons are persons stopping around the own vehicle **101**, and the obstacles include, for example, rocks and the like.

[0144] The roadside objects include, for example, roadside curbs, roadside guardrails, roadside poles, roadside trees, roadside fences, roadside walls, roadside buildings, roadside parked vehicles, roadside parked bicycles, roadside electric poles, and so on. An emergency parking bay is a place provided at a shoulder of a road for getting out of the flow of traffic. Something that obstructs the view of the camera module **111** includes smudges attached to a portion of the windshield **2**, which is located in front of the lens unit **111a** or to at least one of the lenses **121** to **124**. Something that obstructs the view of the camera module **111** also includes sheet members or the like adhered on a portion of the windshield **2**, which is located in front of the lens unit **111a**. The meteorological environments around the own vehicle **101** represent weather information around the own vehicle **101**, such as rain, snow, fog, the degree of backlight, and the like.

[0145] The first processing unit **141a** also performs a lane-marker recognition task for each of the captured images. For example, the first processing unit **141a** recognizes, for each of the captured images, positions of lane markers painted on the road ahead of the own vehicle **101** on which the own vehicle **101** is travelling using, for example, a binarizing process of a corresponding one of the captured images and a Hough transformation process.

[0146] The first processing unit **141a** further performs a light-source recognition task that determines whether there is at least one light source of a vehicle appearing in each of the captured images. Specifically, the first processing unit **141a** determines that there is at least one light source of a vehicle appearing in a currently captured image; the at least one light source has at least one of

[0147] (1) An average pixel value equal to or higher than a threshold pixel value

[0148] (2) A shape similar to one of previously prepared shape patterns

[0149] (3) An average color is similar to one of previously prepared color patterns.

[0150] When it is determined that there is at least one light source appearing in a currently captured image, the first processing unit **141a** identifies a position of the at least one light source on the currently captured image as coordinates on the currently captured image.

[0151] Next, the first processing unit **141a** determines whether the at least one light source is a light source, i.e. a tail lamp, of a preceding vehicle or a light source, i.e. a head lamp, of an oncoming vehicle using, for example, one of known methods. For example, the first processing unit **141a** determines that the at least one light source is a light source of an oncoming vehicle when the average color of the at least one light source is within a predetermined color range similar to white. Otherwise, the first processing unit **141a** determines that the at least one light source is a light source of a preceding vehicle when the average color of the at least one light source is within a predetermined color range similar to red. Thus, the first processing unit **141a** obtains information indicative of whether the at least one light source is a light source of a preceding vehicle or an oncoming vehicle.

[0152] The first processing unit **141a** outputs, to the second processing unit **141b**, the results of the recognition task.

[0153] The second processing unit **141b** is configured to perform, based on the results of the recognition task, at least one of vehicle control tasks including

[0154] (1) A lane departure warning task

[0155] (2) A lane keeping task

[0156] (3) A headlight control task

[0157] (4) A task for preventing broadside collisions

[0158] (5) A task for preventing collisions at intersections

[0159] (6) A task for preventing front collisions

[0160] (7) A sign displaying task

[0161] (8) A speed-limit displaying task

[0162] (9) An over-speed warning task

[0163] (10) An automatic wiper task

[0164] (11) A task for assisting lane changes

[0165] (12) A surround view displaying task

[0166] (13) An automatic parking task

[0167] (14) An adaptive cruise control task

[0168] (15) A blind-spot warning task

[0169] (16) A rear cross-traffic warning task

[0170] (17) A front cross-traffic warning task

[0171] (18) An inter-vehicle distance warning task

[0172] (19) A rear-end collision warning task

[0173] (20) An erroneous start preventing task.

[0174] The lane departure warning task is to determine whether there is an unintentional departure of the own vehicle **101** from a lane on which the own vehicle is running.

[0175] Specifically, the lane departure warning task is configured to determine, based on the lane information and the road shape information recognized by the first processing unit **141a**, whether

[0176] (1) A probability of the own vehicle **101** unintentionally leaving, i.e. departing from, the lane on which the own vehicle **101** is running is higher than a threshold probability or

[0177] (2) The own vehicle **101** has unintentionally left the lane on which the own vehicle **101** was running.

[0178] The lane departure warning task is also configured to control a corresponding actuator of at least one of the warning devices **81** to **84** to activate it when it is determined that

**[0179]** (1) The probability of the own vehicle **101** unintentionally leaving the lane on which the own vehicle **101** is running is higher than the threshold probability or

**[0180]** (2) The own vehicle **101** has unintentionally left the lane on which the own vehicle **101** was running.

**[0181]** The at least one of the warning devices **81** to **84** is activated to output warning information for the occupants of the own vehicle **101**.

**[0182]** For example, each of the buzzer **81** and the speaker **82** is activated to output warning sound for the occupants of the own vehicle **101**.

**[0183]** The lane departure warning task can be configured to send a control signal to the actuator of the steering device **71** to adjust the steering angle of the steering wheel when it is determined that

**[0184]** (1) The probability of the own vehicle **101** unintentionally leaving the lane on which the own vehicle **101** is running is higher than the threshold probability or

**[0185]** (2) The own vehicle **101** has unintentionally left the lane on which the own vehicle **101** was running.

**[0186]** The lane keeping task is configured to send, based on the lane information and the road shape information, a control signal to the actuator of the steering device **71** to adjust the steering angle of the steering, thus keeping the own vehicle **101** within the lane on which the own vehicle **101** is travelling.

**[0187]** The headlight control task, i.e. high- and low-beam switching task and swiveling task, is configured to send, based on the lane information, the road shape information, the road surface information, and the light-source information,

**[0188]** (1) Control signals to first actuators of the headlights via **75** for changing the beams of light output from the headlights **75** between high and low beams

**[0189]** (2) Control signals to second actuators of the headlights **75** for swiveling the axes of the beams of light output from the headlights **75** in the lateral direction of the own vehicle **101**.

**[0190]** The task for preventing broadside collisions is configured to

**[0191]** (1) Determine whether a probability that the own vehicle **101** will collide with at least one moving object, such as a vehicle, a motor cycle, a bicycle, or the like, which is crossing before an intersection in front of the own vehicle **101**, is higher than a predetermined threshold value

**[0192]** (2) Send a control signal to a target actuator, such as the actuator of at least one of the steering device **71** and the brake **72**, to control the target actuator when it is determined that the probability is higher than the threshold value, thus avoiding the collision.

**[0193]** The task for preventing collisions at intersections is designed to

**[0194]** (1) Determine, when the own vehicle **101** is turning at an intersection, whether a probability that the own vehicle **101** will collide with at least one object, such as a vehicle, a motor cycle, a bicycle, a pedestrian, or the like, located around the own vehicle **101**, is higher than a predetermined threshold value

**[0195]** (2) Send a control signal to a target actuator, such as the actuator of at least one of the steering device **71** and the brake **72**, to control the target actuator when it is determined that the probability is higher than the threshold value, thus avoiding the collision.

**[0196]** The task for preventing front collisions is designed to

**[0197]** (1) Determine whether a probability that the own vehicle **101** will collide with at least one object, such as a preceding vehicle, a motor cycle, a bicycle, a pedestrian, or the like, located ahead of the own vehicle **101** is higher than a predetermined threshold value

**[0198]** (2) Send a control signal to a target actuator, such as the actuator of at least one of the steering device **71** and the brake **72**, to control the target actuator when it is determined that the probability is higher than the threshold value, thus avoiding the collision.

**[0199]** Note that each of the tasks for preventing broadside collisions, the task for preventing collisions at intersections, and the task for preventing front collisions includes a task for

**[0200]** 1. Determining whether the own vehicle **101** can pass through a tunnel or below an advertising sign when the tunnel or the advertising sign is detected ahead of the own vehicle **101**

**[0201]** 2. Sending a control signal to a target actuator, such as the actuator of at least one of the buzzer **81** and the speaker **82**, to control the target actuator when it is determined that the own vehicle **101** cannot pass through the detected tunnel or below the detected advertising sign, thus avoiding a collision with the detected tunnel or the detected advertising sign.

**[0202]** Each of the task for preventing broadside collisions and the task for preventing collisions at intersections is performed based on, for example, the results of the recognition task associated with

**[0203]** 1. The road surface information

**[0204]** 2. The preceding-vehicle and oncoming-vehicle information

**[0205]** 3. The stopped-vehicle information

**[0206]** 4. The preceding-pedestrian and oncoming-pedestrian information

**[0207]** 5. The stopped-person information

**[0208]** 6. The motor-cycle and bicycle information

**[0209]** 7. The obstacle and roadside-object information

**[0210]** 8. The advertising-sign information

**[0211]** 9. The tunnel information.

**[0212]** The sign displaying task is designed to send, based on at least one of the traffic-sign information, the traffic-signal information, the traffic-marking information, and the advertising-sign information, a control signal to the actuator of the display **84**. This enables the display **84** to display at least one of the traffic-sign information, the traffic-signal information, the traffic-marking information, and the advertising-sign information.

**[0213]** The speed-limit displaying task is designed to send, based on the traffic-sign information, a control signal to the actuator of the display **84** so that the display **84** displays a speed limit if the speed limit is indicated by the traffic-sign information.

**[0214]** The overspeed warning task is designed to

**[0215]** 1. Determine whether the speed of the own vehicle **101** is exceeding the speed limit indicated by the traffic-sign information

**[0216]** 2. Send a control signal to the actuator of at least one of the buzzer **81** and the speaker **82** when it is determined that the speed of the own vehicle **101** is exceeding the speed limit indicated by the traffic-sign information.

[0217] The control signal controls the actuator of at least one of the buzzer **81** and the speaker **82**, so that at least one of the buzzer **81** and the speaker **82** audibly outputs a warning to occupants of the own vehicle **101**; the warning represents the overspeed of the own vehicle **101**.

[0218] The automatic wiper task is designed to

[0219] (1) Determine whether the driver's visibility is lower than a predetermined threshold value based on the road surface information and the meteorological-environment information

[0220] (2) Send a control signal to the actuator of at least one of the wipers **77** so that at least one of the wipers **77** is activated to clean a corresponding at least one of the front windshield **2** and rear windshield from rain, snow, or other moisture.

[0221] The task for assisting lane changes is designed to, for example, detect another vehicle travelling in a target lane adjacent to the lane on which the own vehicle **101** is travelling based on the preceding-vehicle information. Then, the task for assisting lane changes is designed to send control signals to the actuators of the respective steering device **71**, brake **72**, transmission **74**, and directional indicator **76** to control the devices **71**, **72**, **74**, and **76** for assisting the driver's operation for a lane change to the target lane according to the detected adjacent vehicle.

[0222] The surround view displaying task is designed to send, to the actuator of the display **84**, a control signal so that the display **84** displays a surround-view image covering the surroundings of the own vehicle **101**. The automatic parking task is designed to send control signals to the actuators of the respective steering device **71** and brake **72** for automatically parking the own vehicle **101** to a desired position. The adaptive cruise control task is designed to send control signals to the actuators of the respective brake **72**, motive power generator **73**, and transmission **74** for controlling the speed of the own vehicle **101** to track a target preceding vehicle.

[0223] Each of the task for assisting lane changes, surround view displaying task, automatic parking task, and adaptive cruise control task is performed based on, for example, the results of the recognition task associated with

[0224] 1. The lane and road shape information

[0225] 2. The preceding-vehicle and oncoming-vehicle information

[0226] 3. The stopped-vehicle information

[0227] 4. The preceding-pedestrian and oncoming-pedestrian information

[0228] 5. The stopped-person information

[0229] 6. The motor-cycle and bicycle information

[0230] 7. The obstacle and roadside-object information

[0231] 8. The advertising-sign and traffic-signal information

[0232] 9. The traffic-marking information.

[0233] The blind-spot warning task is designed to

[0234] (1) Determine whether another vehicle is entering a blind spot at a rear corner of the travelling own vehicle **101**

[0235] (2) Send a control signal to the actuator of at least one of the buzzer **81** and the speaker **82** when it is determined that another vehicle is entering a blind spot at a rear corner of the travelling own vehicle **101**.

[0236] The control signal controls the actuator of at least one of the buzzer **81** and the speaker **82**, so that at least one of the buzzer **81** and the speaker **82** audibly outputs a

warning to occupants of the own vehicle **101**. The warning represents the entrance of another vehicle into a blind spot around the own vehicle **101**.

[0237] The rear cross-traffic warning task is designed to  
[0238] (1) Determine whether another vehicle is entering a blind spot around the rear end of the own vehicle **101** when the own vehicle **101** is rolling backward

[0239] (2) Send a control signal to the actuator of at least one of the buzzer **81** and the speaker **82** when it is determined that another vehicle is entering the blind spot around the rear end of the own vehicle **101**.

[0240] The control signal controls the actuator of at least one of the buzzer **81** and the speaker **82**, so that at least one of the buzzer **81** and the speaker **82** audibly outputs a warning to occupants of the own vehicle **101**.

[0241] The warning represents the entrance of another vehicle into the blind spot around the rear end of the own vehicle **101**.

[0242] The front cross-traffic warning task is designed to

[0243] (1) Determine whether another vehicle exists at a blind spot around the front end of the own vehicle **101** when the own vehicle **101** is located at a blind intersection

[0244] (2) Send a control signal to the actuator of at least one of the buzzer **81** and the speaker **82** when it is determined that another vehicle exists at the blind spot around the front end of the own vehicle **101**.

[0245] The control signal controls the actuator of at least one of the buzzer **81** and the speaker **82**, so that at least one of the buzzer **81** and the speaker **82** audibly outputs a warning to occupants of the own vehicle **101**. The warning represents that another vehicle exists at the blind spot around the front end of the own vehicle **101**.

[0246] Each of the blind-spot warning task, rear cross-traffic warning task, and front cross-traffic warning task is performed based on, for example, the results of the image recognition task associated with

[0247] 1. The preceding-vehicle and oncoming-vehicle information

[0248] 2. The stopped-vehicle information

[0249] 3. The preceding-pedestrian and oncoming-pedestrian information

[0250] 4. The stopped-person information

[0251] 5. The motor-cycle and bicycle information

[0252] 6. The obstacle and roadside-object information

[0253] 7. The traffic-sign and traffic-signal information

[0254] 8. The traffic-marking information.

[0255] The inter-vehicle distance warning task is designed to

[0256] (1) Detect an inter-vehicle distance between the own vehicle **101** and a target preceding vehicle

[0257] (2) Determine whether the detected inter-vehicle distance is shorter than a predetermined threshold distance

[0258] (3) Send a control signal to the actuator of at least one of the buzzer **81** and the speaker **82** when it is determined that the detected inter-vehicle distance is shorter than the threshold distance.

[0259] The control signal controls the actuator of at least one of the buzzer **81** and the speaker **82**, so that at least one of the buzzer **81** and the speaker **82** audibly outputs a warning to occupants of the own vehicle **101**. The warning represents that the inter-vehicle distance is shorter than the threshold distance.

[0260] The rear-end collision warning task is designed to

[0261] (1) Determine whether a probability that the own vehicle 101 will collide with the rear end of a preceding vehicle is equal to or higher than a predetermined threshold value

[0262] (2) Send a control signal to the actuator of at least one of the buzzer 81 and the speaker 82 when it is determined that the probability that the own vehicle 101 will collide with the rear end of a preceding vehicle is equal to or higher than the threshold value.

[0263] The control signal controls the actuator of at least one of the buzzer 81 and the speaker 82, so that at least one of the buzzer 81 and the speaker 82 audibly outputs a warning to occupants of the own vehicle 101. The warning represents the danger of collision of the own vehicle 101 with the rear end of a preceding vehicle. Note that the inter-vehicle distance warning task and rear-end collision warning task are performed based on, for example, the results of the image recognition task associated with the preceding-vehicle information.

[0264] The erroneous start preventing task is designed to determine whether an accelerator pedal of the own vehicle 101 is operated by a driver of the own vehicle 101 being parked although there is a building or structure in front of the own vehicle 101. Note that whether the accelerator pedal of the own vehicle 101 is operated by the driver of the own vehicle 101 can be measured by an accelerator sensor included in the sensor module 6. The erroneous start preventing task is also designed to send a control signal to the actuator of the brake 72 when it is determined that the accelerator pedal of the own vehicle 101 is operated by the driver of the own vehicle 101 being parked although there is a building or structure in front of the own vehicle 101. The control signal controls the actuator of the brake 72 to prevent start of the own vehicle 101 due to such a driver's erroneous operation of the accelerator pedal. The erroneous start preventing task is performed based on, for example, the results of the image recognition task associated with the building structure information.

[0265] Note that the second processing unit 141b can be configured to stop one or more of the above vehicle control tasks based on the actuators of target devices associated with motion of the own vehicle 101, such as the steering device 71 and the brake 72, when it is determined that something blocks the view of the camera module 111 based on the camera-view blocking information. The second processing unit 141b can be configured to stop one or more vehicle control tasks when it is determined, based on the meteorological-environment information, that it is difficult to perform the image recognition task according to images picked up by the camera module 111 due to adverse weather conditions including, for example, torrential downpours.

[0266] Note that the camera module 111 includes a temperature sensor for measuring the temperature in the camera module 111. The temperature sensor is configured to send, to the first processing unit 141a, a temperature signal indicative of the measured temperature in the camera module 111.

[0267] The first processing unit 141a receives the temperature signal sent from the temperature sensor, and determines whether the temperature in the camera module 111 based on the received temperature signal is equal to or higher than a predetermined threshold temperature. Addi-

tionally, the first processing unit 141a determines whether there is something that blocks the view of the camera module 111.

[0268] When it is determined that the temperature in the camera module 111 based on the received temperature signal is equal to or higher than the threshold temperature, the first processing unit 141a performs, as the recognition task, the second recognition task based on the object information measured by the radar device 52 in priority to the first recognition task. Similarly, when it is determined that there is something that blocks the view of the camera module 111, the first processing unit 141a performs, as the recognition task, the second recognition task based on the object information measured by the radar device 52 in priority to the first recognition task.

[0269] Otherwise, when it is determined neither that the temperature in the camera module 111 based on the received temperature signal is equal to or higher than the threshold temperature nor that there is something that blocks the view of the camera module 111, the first processing unit 141a performs, as the recognition task, the first recognition task based on images captured by the camera module 111.

[0270] The first processing unit 141a can be configured to perform at least one of the first recognition task and the second recognition task as the above recognition task. For example, the first processing unit 141a can perform only the first recognition task as the above recognition task without performing the second recognition task. The first processing unit 141a can also be configured to perform, as the above recognition task, a fusion recognition task based on combination of images captured by the camera module 111 and the object information measured by the radar device 52.

#### Advantageous Effects

[0271] The camera apparatus 1 according to the first embodiment is configured to recognize, based on images captured by the camera module 111, the situations around the own vehicle 101, and performs, based on the results of the recognition, the various vehicle control tasks set forth above. The above configured camera module 111 of the camera apparatus 1 enables higher-quality images in front of the own vehicle 101 to be captured. This enables the camera apparatus 1 to perform the various vehicle control tasks each with higher accuracy.

[0272] The main reason why the camera module 111 captures higher-quality images than a conventional camera module is that the imager 131 of the camera module 111 is designed as a curved imager such that the photo-sensor array 132 of the imager 131 is concavely curved with respect to the lens unit 111a.

[0273] The curved imager 131 has higher sensitivity at the peripheral portion of the imaging surface 132a, i.e. the photo-sensor array 132 as compared with a flat imager whose imaging surface is flat. This enables the curved imager 131 to capture higher-quality images as compared with the flat imager. Additionally, the curved imager 131 captures images each having lower aberrations at the peripheral portion thereof as compared with a flat imager. The curved imager 131 also has lower dark current as compared with such a flat imager, because the curved semiconductor photodiodes reduce dark current to be lower than the dark current of such a flat imager. This reduces the level of noise obtained in the curved imager 131 to be lower than the level

of noise obtained in such a flat imager, resulting in the curved imager **131** having a wider dynamic range than such a flat imager has.

[0274] Higher-accuracy vehicle control requires image sensors each having a wider effective field of view, in other words, requires image sensors each having higher sensitivity at the peripheral portion of the imaging surface of the corresponding image sensor. For example, recognizing, with higher accuracy, the situations of the intersection in front of a running vehicle or detecting whether a pedestrian is leaping out to the road in front of a running vehicle requires images captured by camera apparatuses; each of the images has a resolution at its peripheral portion as high as a resolution at its center portion. This is because the captured images, each of which has a resolution at its peripheral portion as high as a resolution at its center portion, enable vehicles or pedestrians located at the peripheral portion of each captured image to be accurately recognized.

[0275] The camera apparatus **1** according to the first embodiment, which includes the camera module **111** configured above, achieves captured images each having higher quality. This results in the camera apparatus **1** improving the object-recognition performance at the peripheral portion of each captured image and the object-recognition performance of each image captured during night-time.

[0276] The camera apparatus **1** according to the first embodiment, which includes the camera module **111** configured above, achieves captured images each having lower aberrations at the peripheral portion thereof. This results in reduction of the number of lenses in the lens unit **111a**, which is required to capture higher-quality images, as compared with a case where the camera module **111** uses a flat imager.

[0277] The reduction in the number of lenses in the lens unit **111a** reduces flare and ghost images in each of images captured by the image sensor **11**, resulting in the camera apparatus **1** having an improved target recognition performance. The reduction in the number of lenses in the lens unit **111a** downsizes the lens unit **111a**, resulting in the camera apparatus **1** having a smaller size. The reduction in size of the camera apparatus **1** results in an improvement of the driver's viewability in front of the own vehicle **101**, an improvement of the appearance in the occupant compartment of the own vehicle **101**, and a reduction of the manufacturing and transporting cost of the camera apparatus **1**.

[0278] The camera apparatus **1** according to the first embodiment, which includes the camera module **111** configured above, achieves a wider high-temperature operating range as compared with such a flat imager, because the curved semiconductor photodiodes of the camera module **111** increase the high-temperature operating range thereof to be higher than the high-temperature operating range of such a flat imager. This reduces the adverse effects due to heat generated by the camera apparatus **1**, thus improving the operational stability of the camera apparatus **1**; the amount of heat depends on the temperature environments around the own vehicle **101** and/or on the higher functionality of the camera module **111**, such as higher resolution and higher frame rate thereof.

#### Second Embodiment

[0279] The following describes an in-vehicle system **200**, which includes a camera apparatus **203**, according to the second embodiment.

[0280] The structure and functions of the in-vehicle system **200** according to the second embodiment are mainly different from those of the in-vehicle system **100** according to the first embodiment by the following point.

#### Structure of in-Vehicle System

[0281] Referring to FIG. **10**, the in-vehicle system **200** includes the camera apparatus **203** and a controller **205** installed in the rearview mirror **105** of the own vehicle **101**.

#### Structure of Camera Apparatus

[0282] Referring to FIG. **10**, the camera apparatus **203**, which is designed as, for example, a monocular camera apparatus, includes, for example, an image sensor **207**, a plate-like bracket **12A**, and a cover **223**. Reference numeral **105a** represents a support member mounted on the inner surface of the windshield **2** and configured to support the rearview mirror **105**.

[0283] The image sensor **207** according to the second embodiment is substantially identical in structure to the image sensor **11** according to the first embodiment except that the imager **131** includes no control board **113**. Specifically, the image sensor **207** includes, for example, a camera module **211**, a housing **114A**, and a bottom cover **115**. The camera module **211** includes, for example, an imaging board **211c** (see FIG. **11**) in place of the imaging board **111c** according to the first embodiment. The camera module **211** is contained in the assembly of the housing **114A** and the bottom cover **115** like the first embodiment.

[0284] The imaging board **211c** includes the imager **131**, a control circuit **203**, and a connector **218**.

[0285] The control circuit **213** includes a power source **214**, an image-signal I/F **215**, and a control-signal I/F **216**. The control circuit **213** is connected to the controller **205** via the connector **218** and a communication line **221**.

[0286] The power source **214** supplies operating power to each of the electrical components constituting the imaging board **211c**. The image-signal I/F **215** receives the image signal output from the imager **131**, and outputs the image signal to the controller **205** via the connector **218** and the communication line **221**. The control-signal I/F **216** receives control signals sent from the controller **205** via the connector **218** and the communication line **221**; the control signals are operative to control how the imager **131** operates. That is, the control-signal I/F **216** enables the control signals sent from the controller **205** to control the photo-sensor array **132** and the exposure controller **135** of the imager **131**.

[0287] Like the first embodiment, the housing **114A** is configured such that the lens unit **111a** and the lens barrel **111b** are exposed to the front direction of the own vehicle **101**. Like the first embodiment, the housing **114a** of the image sensor **207** is mounted on the inner surface of the windshield **2** with the bracket **12A**.

[0288] Referring to FIG. **10**, the communication line **221** is disposed in the support member **105a** and the rearview mirror **105** so as to be connected to the controller **205** installed in the rearview mirror **105**. This enables the communication line **221** to be securely connected between the connector **218** and the controller **205** installed in the rearview mirror **105**.

[0289] The cover **223** is mounted to the bottom cover **115** and to the support member **105a** to cover the image sensor **207** and the communication line **221**. That is, the cover **223**

extends from the bottom cover **115** to the support member **105a**. This enables the communication line **221** to not be exposed to the inside of the occupant compartment of the own vehicle **101**.

#### Structure of Control Apparatus

[0290] Referring to FIG. **12**, the controller **205** includes the signal processor **141**, a camera interface (I/F) **231**, a device interface **233**, and a power source **235**.

[0291] The camera I/F **231** is connected to the signal processor **141** and to one end of the communication line **221**, the other end of which is connected to the camera module **211** via the connector **218**. The camera I/F **231** serves as an interface that enables each of the first and second processing units **141a** and **141b** to communicate with the camera module **211** via the communication line **221**.

[0292] The device I/F **233** serves as an interface that enables each of the first and second processing units **141a** and **141b** to communicate with the electronic devices **151** installed in the own vehicle **101**. For example, the device I/F **233** includes connectors and an electric or electronic circuit when the image sensor **207** is connected to the electronic devices **151** via communication lines CL. The connectors are connected to the respective communication lines CL, and the electronic circuit establishes communications between the electronic devices **151** and each of the first and second processing units **141a** and **141b**.

[0293] The power source **235** is configured to receive electrical power supplied from an accessory power source and/or a battery installed in the own vehicle **101**. Then, the power source **235** supplies electrical power to the individual components of the controller **205**.

[0294] As described above, the camera apparatus **203** according to the second embodiment is configured such that a part of the camera apparatus **203**, i.e. the controller **205**, is mounted to the rearview mirror **105** to be separated from the image sensor **207**. This enables the image sensor **207** of the camera apparatus **203** to be downsized. This downsizing of the image sensor **207** results in an improvement of the driver's viewability in front of the own vehicle **101**, an improvement of the appearance in the occupant compartment of the own vehicle **101**, and a reduction of the manufacturing and transporting cost of the camera apparatus **203**.

[0295] The present disclosure is not limited to the aforementioned embodiments. Elements of each of the camera apparatuses **1** and **203** are not essential to camera apparatuses within the scope of the present disclosure except where the elements are clearly described as essential elements or the elements are obviously to be essential. Even if the number of elements, the values of elements, the amounts of elements, and the ranges of elements are disclosed in the specification, the present disclosure is not limited thereto except where they are clearly described as essential or they are principally estimated to be essential. Even if the shapes, locations, and positional relationships of elements are disclosed in the specification, the present disclosure is not limited thereto except if they are clearly described as essential or they are principally estimated to be essential.

[0296] Specifically, the following modifications can be included within the scope of the present disclosure, and the modifications can be selectively applied to the first and second embodiments in combination or alone. That is, at least some of the modifications can be freely applied to the first and second embodiments.

[0297] The features disclosed in the first and second embodiments can be freely combined with one another within the scope of the present disclosure.

[0298] The controller **205** according to the second embodiment can be disposed to another place in the own vehicle **105**, which differs from the rearview mirror **105**. The image-signal I/F **215** and control-signal I/F **216** according to this modification can be configured as communication modules that wirelessly communicate with the controller **205**.

[0299] The first processing unit **141a** according to the first and second embodiments is configured to perform the recognition task that recognizes the situations around the own vehicle **101**, but can be configured to perform a part of the recognition task. For example, the first processing unit **141a** and at least one of the electronic devices **151** installed in the own vehicle **101** can be configured to cooperatively perform the recognition task that recognizes the situations around the own vehicle **101**.

[0300] The second processing unit **141b** according to the first and second embodiments is configured to perform, based on the recognized situations around the own vehicle **101**, the vehicle control task that controls at least one of the actuators or other similar devices installed in the own vehicle **101**. For example, the second processing unit **141b** and at least one of the electronic devices **151** installed in the own vehicle **101** can be configured to cooperatively perform the vehicle control task that controls at least one of the actuators or other similar devices installed in the own vehicle **101**.

[0301] The first processing unit **141a** and the second processing unit **141b** according to the first embodiment or second embodiment constitute functional modules of the signal processor **141** installed in the control board **113** (first embodiment) or the controller **205** (second embodiment). In other words, the first processing unit **141a** and the second processing unit **141b** according to each of the first and second embodiments are constructed of the same electronic components of the signal processor **141**. The first processing unit **141a** and the second processing unit **141b** however can be constructed of different electronic components, such as integrated circuits, chipsets, microcomputers, and circuit boards.

[0302] Specifically, the common chipset or microcomputer can construct both the first processing unit **141a** and the second processing unit **141b**, or different chipsets or microcomputers can construct the respective first and second processing units **141a** and **141b**. Similarly, the common control board can construct both the first processing unit **141a** and the second processing unit **141b**, or different control boards can construct the respective first and second processing units **141a** and **141b**.

[0303] The assembly of the housing **114** and the bottom cover **115** according to the first embodiment is configured to house the camera module **111**, the control board **113**, the power source **145**, and the electrical connection harness **112**. The assembly of the housing **114** and the bottom cover **115** can be configured to house at least one of the camera module **111**, the control board **113**, the power source **145**, and the electrical connection harness **112**.

[0304] The assembly of the housing **114** and the bottom cover **115** can house at least one of the different electronic components if the different electronic components construct the respective first processor **114a** and the second processor **114b**.

[0305] The cover 16 covers the image sensor 11, the bracket 12, and the hood 13 from below, but can be configured to cover at least a part of the camera module 111, the signal processor 141, the communication I/F 143, the power source 145, the housing 114, and the bottom cover 115. The cover 16 can cover at least one of the different electronic components if the different electronic components construct the respective first processor 114a and the second processor 114b.

[0306] The assembly of the housing 114A and the bottom cover 115 according to the second embodiment is configured to house the camera module 211. The assembly of the housing 114A and the bottom cover 115 can be configured to house at least one of the camera module 211, the image-signal I/F 215, the control-signal I/F 216, and the power source 214.

[0307] The cover 223 covers the image sensor 207 and the communication line 221, but can be configured to cover at least a part of the camera module 211, the image-signal I/F 215, the control-signal I/F 216, the power source 214, the housing 114A, and the bottom cover 115.

[0308] Each of the camera apparatuses 1 and 203 according to the first and second embodiment is designed as a monocular camera apparatus, but can be designed as a stereo camera apparatus.

[0309] Each of the brackets 12 and 12A according to the first and second embodiment can have one of various structures and shapes as long as the corresponding bracket is configured to fixedly mount a corresponding one of the camera modules 111 and 211 to the windshield 2 via a corresponding one of the housings 114 and 114A. That is, one or more elements can be interposed between each of the camera modules 111 and 211 and a corresponding one of the brackets 114 and 114A as long as the corresponding camera module is fixedly mounted to the windshield 2 with the corresponding bracket. Similarly, one or more elements can be interposed between each of the camera modules 111 and 114A and the windshield 2 as long as the corresponding camera module is fixedly mounted to the windshield 2 with the corresponding bracket.

[0310] The first processing unit 141a according to the first and second embodiments can be configured to perform the recognition task to recognize a selected one of

- [0311] (1) The lane information
- [0312] (2) The road shape information
- [0313] (3) The road surface information
- [0314] (4) The light source information
- [0315] (5) The preceding-vehicle information
- [0316] (6) The oncoming-vehicle information
- [0317] (7) The stopped-vehicle information
- [0318] (8) The preceding-pedestrian information
- [0319] (9) The oncoming-pedestrian information
- [0320] (10) The stopped-person information
- [0321] (11) The motor-cycle information
- [0322] (12) The bicycle information
- [0323] (13) The obstacle information
- [0324] (14) The roadside-object information
- [0325] (15) The traffic-sign information
- [0326] (16) The traffic-signal information
- [0327] (17) The traffic-marking information
- [0328] (18) The advertising-sign information
- [0329] (19) The tunnel information
- [0330] (20) The emergency-bay information
- [0331] (21) The camera-view blocking information

[0332] (22) The meteorological-environment information

[0333] (23) The building structure information.

[0334] The second processing unit 141b according to the first and second embodiments can be configured to select at least two of the lane departure warning task, headlight control task, and the task for preventing front collisions, and perform the selected at least two tasks. The second processing unit 141b according to the first and second embodiments can also be configured to perform, in addition to the selected at least two tasks, at least one of the following tasks

- [0335] 1. The lane keeping task
- [0336] 2. The task for preventing broadside collisions
- [0337] 3. The task for preventing collisions at intersections
- [0338] 4. The sign displaying task
- [0339] 5. The speed-limit displaying task
- [0340] 6. The over-speed warning task
- [0341] 7. The automatic wiper task
- [0342] 8. The task for assisting lane changes
- [0343] 9. The surround view displaying task
- [0344] 10. The automatic parking task
- [0345] 11. The adaptive cruise control task
- [0346] 12. The blind-spot warning task
- [0347] 13. The rear cross-traffic warning task
- [0348] 14. The front cross-traffic warning task
- [0349] 15. The inter-vehicle distance warning task
- [0350] 16. The rear-end collision warning task
- [0351] 17. The erroneous start preventing task.

[0352] While the illustrative embodiments and their modifications of the present disclosure have been described herein, the present disclosure is not limited to the embodiments and their modifications described herein. Specifically, the present disclosure includes any and all embodiments having modifications, omissions, combinations (e.g., of aspects across various embodiments), adaptations and/or alternations as would be appreciated by those in the art based on the present disclosure. The limitations in the claims are to be interpreted broadly based on the language employed in the claims and not limited to examples described in the present specification or during the prosecution of the application, which examples are to be construed as non-exclusive.

What is claimed is:

1. A camera apparatus installable to a vehicle that includes a windshield and an electronic device installed thereto, the camera apparatus comprising:

a camera module having a predetermined field of view and configured to capture an image in front of the vehicle via a predetermined wiping area of the windshield of the vehicle;

a first processing unit configured to perform, based on the image captured by the camera module, at least part of a recognition task that recognizes situations in front of the vehicle;

a second processing unit configured to perform, based on a result of the recognition task performed by the first processing unit, at least part of a vehicle control task, the vehicle control task including at least two of:

a lane departure warning task for determining whether there is an unintentional departure of the vehicle from a lane on which the vehicle is running;

a headlight control task for controlling a headlight of the vehicle; and

a task for preventing front collisions of the vehicle;

- a communication interface that enables the first and second processing units to communicate with the electronic device installed in the vehicle;
  - a power source that supplies electrical power to the camera module, the first processing unit, and the second processing unit;
  - a housing configured to house at least part of at least one of the camera module, the first processing unit, the second processing unit, the communication interface, and the power source;
  - a cover configured to cover at least part of at least one of the camera module, the first processing unit, the second processing unit, the communication interface, the power source, and the housing; and
  - a mounting member configured to fixedly mount the camera module to the windshield of the vehicle such that the field of view of the camera module is directed in front of the vehicle,
- the camera module comprising:
- a lens unit comprising a plurality of lenses;
  - a barrel configured to house the lens unit; and
  - an imager having an imaging surface and arranged with respect to the lens unit such that light passing through the plurality of lenses of the lens unit forms an image on the imaging surface, the imager comprising at least part of an exposure controller that controls an exposure of the imaging surface, the imaging surface being concavely curved with respect to the lens unit.
2. The camera apparatus according to claim 1, wherein the recognition task includes at least one of:
- (i) lanes ahead of the vehicle;
  - (ii) a shape of a road ahead of the vehicle;
  - (iii) a condition of a road surface ahead of the vehicle;
  - (iv) at least one light source ahead of the vehicle;
  - (v) at least one preceding vehicle ahead of the vehicle;
  - (vi) at least one oncoming vehicle;
  - (vii) at least one stopped vehicle around the vehicle;
  - (viii) at least one preceding pedestrian around the vehicle;
  - (ix) at least one oncoming pedestrian ahead of the vehicle;
  - (x) at least one stopping person around the vehicle;
  - (xi) at least one motor cycle around the vehicle;
  - (xii) at least one bicycle around the vehicle;
  - (xiii) at least one obstacle around the vehicle;
  - (xiv) at least one roadside object around the vehicle;
  - (xv) at least one traffic sign around the vehicle;
  - (xvi) at least one traffic signal around the vehicle;
  - (xvii) at least one traffic marking around the vehicle;
  - (xviii) at least one advertising sign around the vehicle;
  - (xix) a tunnel through which the vehicle is going to go;
  - (xx) at least one emergency parking bay;
  - (xxi) something that blocks the view of the camera module;
  - (xxii) a meteorological environment around the vehicle; and
  - (xxiii) at least one building structure around the vehicle.
3. The camera apparatus according to claim 1, wherein the second processing unit is configured to perform, in addition to the at least two of the lane departure warning task, the headlight control task, and the task for preventing front collisions of the vehicle, at least one of:
- (a) a lane keeping task;
  - (b) a task for preventing broadside collisions;
  - (c) a task for preventing collisions at intersections;
  - (d) a sign displaying task;
  - (e) a speed-limit displaying task;
  - (f) an over-speed warning task;
  - (g) an automatic wiper task;
  - (h) a task for assisting lane changes;
  - (i) a surround view displaying task;
  - (j) an automatic parking task;
  - (k) an adaptive cruise control task;
  - (l) a blind-spot warning task;
  - (m) a rear cross-traffic warning task;
  - (n) a front cross-traffic warning task;
  - (o) an inter-vehicle distance warning task;
  - (p) a rear-end collision warning task; and
  - (q) an erroneous start preventing task.
4. The camera apparatus according to claim 2, wherein the second processing unit is configured to perform, in addition to the at least two of the lane departure warning task, the headlight control task, and the task for preventing front collisions of the vehicle, at least one of:
- (a) a lane keeping task;
  - (b) a task for preventing broadside collisions;
  - (c) a task for preventing collisions at intersections;
  - (d) a sign displaying task;
  - (e) a speed-limit displaying task;
  - (f) an over-speed warning task;
  - (g) an automatic wiper task;
  - (h) a task for assisting lane changes;
  - (i) a surround view displaying task;
  - (j) an automatic parking task;
  - (k) an adaptive cruise control task;
  - (l) a blind-spot warning task;
  - (m) a rear cross-traffic warning task;
  - (n) a front cross-traffic warning task;
  - (o) an inter-vehicle distance warning task;
  - (p) a rear-end collision warning task; and
  - (q) an erroneous start preventing task.
5. The camera apparatus according to claim 1, wherein the first processing unit and the second processing unit are functional components constructed by a common electronic component.
6. An in-vehicle system comprising:
- a camera apparatus installed in a vehicle, the vehicle including a windshield, a rearview mirror, and an electronic device installed thereto; and
  - a controller installed in the rearview mirror, the camera apparatus comprising:
    - a camera module having a predetermined field of view and configured to capture an image in front of the vehicle via a predetermined wiping area of the windshield of the vehicle;
    - a first communication interface that enables the camera module to communicate with the controller;
    - a power source that supplies electrical power to the camera module;
    - a housing configured to house at least part of at least one of the camera module, the first communication interface, and the power source;
    - a cover configured to cover at least part of at least one of the camera module, the first communication interface, the power source, and the housing; and
    - a mounting member configured to fixedly mount the camera module to the windshield of the vehicle such that the field of view of the camera module is directed in front of the vehicle,



the camera module comprising:

- a lens unit comprising a plurality of lenses;
- a barrel configured to house the lens unit; and
- an imager having an imaging surface and arranged with respect to the lens unit such that light passing through the plurality of lenses of the lens unit forms an image on the imaging surface, the imager comprising at least part of an exposure controller that controls an exposure of the imaging surface, the imaging surface being concavely curved with respect to the lens unit,

the controller comprising:

- a second communication interface that enables the controller to communicate with the camera module;
- a first processing unit configured to perform, based on the image captured by the camera module, at least part of a recognition task that recognizes situations in front of the vehicle;
- a second processing unit configured to perform, based on a result of the recognition task performed by the first processing unit, at least part of a vehicle control task,

the vehicle control task including at least two of: a lane departure warning task for determining whether there is an unintentional departure of the vehicle from a lane on which the vehicle is running, a headlight control task for controlling a headlight of the vehicle, and a task for preventing front collisions of the vehicle;

- a third communication interface that enables the first and second processing units to communicate with the electronic device installed in the vehicle; and
- a power source that supplies electrical power to the first processing unit and the second processing unit.

7. The in-vehicle system according to claim 6, wherein the recognition task includes at least one of:

- (i) lanes ahead of the vehicle;
- (ii) a shape of a road ahead of the vehicle;
- (iii) a condition of a road surface ahead of the vehicle;
- (iv) at least one light source ahead of the vehicle;
- (v) at least one preceding vehicle ahead of the vehicle;
- (vi) at least one oncoming vehicle;
- (vii) at least one stopped vehicle around the vehicle;
- (viii) at least one preceding pedestrian around the vehicle;
- (ix) at least one oncoming pedestrian ahead of the vehicle;
- (x) at least one stopping person around the vehicle;
- (xi) at least one motor cycle around the vehicle;
- (xii) at least one bicycle around the vehicle;
- (xiii) at least one obstacle around the vehicle;
- (xiv) at least one roadside object around the vehicle;
- (xv) at least one traffic sign around the vehicle;
- (xvi) at least one traffic signal around the vehicle;
- (xvii) at least one traffic marking around the vehicle;
- (xviii) at least one advertising sign around the vehicle;
- (xix) a tunnel through which the vehicle is going to go;
- (xx) at least one emergency parking bay;
- (xxi) something that blocks the view of the camera module;
- (xxii) a meteorological environment around the vehicle; and
- (xxiii) at least one building structure around the vehicle.

8. The camera apparatus according to claim 6, wherein the second processing unit is configured to perform, in addition to the at least two of the lane departure warning task, the

headlight control task, and the task for preventing front collisions of the vehicle, at least one of:

- (a) a lane keeping task;
- (b) a task for preventing broadside collisions;
- (c) a task for preventing collisions at intersections;
- (d) a sign displaying task;
- (e) a speed-limit displaying task;
- (f) an over-speed warning task;
- (g) an automatic wiper task;
- (h) a task for assisting lane changes;
- (i) a surround view displaying task;
- (j) an automatic parking task;
- (k) an adaptive cruise control task;
- (l) a blind-spot warning task;
- (m) a rear cross-traffic warning task;
- (n) a front cross-traffic warning task;
- (o) an inter-vehicle distance warning task;
- (p) a rear-end collision warning task; and
- (q) an erroneous start preventing task.

9. The camera apparatus according to claim 7, wherein the second processing unit is configured to perform, in addition to the at least two of the lane departure warning task, the headlight control task, and the task for preventing front collisions of the vehicle, at least one of:

- (a) a lane keeping task;
- (b) a task for preventing broadside collisions;
- (c) a task for preventing collisions at intersections;
- (d) a sign displaying task;
- (e) a speed-limit displaying task;
- (f) an over-speed warning task;
- (g) an automatic wiper task;
- (h) a task for assisting lane changes;
- (i) a surround view displaying task;
- (j) an automatic parking task;
- (k) an adaptive cruise control task;
- (l) a blind-spot warning task;
- (m) a rear cross-traffic warning task;
- (n) a front cross-traffic warning task;
- (o) an inter-vehicle distance warning task;
- (p) a rear-end collision warning task; and
- (q) an erroneous start preventing task.

10. The camera apparatus according to claim 6, wherein the first processing unit and the second processing unit are functional components constructed by a common electronic component.

11. A camera apparatus installable to a vehicle that includes a windshield and an electronic device installed thereto, the camera apparatus comprising:

- a camera module having a predetermined field of view and configured to capture an image in front of the vehicle via a predetermined wiping area of the windshield of the vehicle;
- a communication interface that enables the camera module to communicate with the electronic device installed in the vehicle;
- a power source that supplies electrical power to the camera module;
- a housing configured to house at least part of at least one of the camera module, the communication interface, and the power source;
- a cover configured to cover at least part of at least one of the camera module, the communication interface, the power source, and the housing; and

a mounting member configured to fixedly mount the camera module to the windshield of the vehicle such that the field of view of the camera module is directed in front of the vehicle,

the camera module comprising:

a lens unit comprising a plurality of lenses;

a barrel configured to house the lens unit; and

an imager having an imaging surface and arranged with respect to the lens unit such that light passing through the plurality of lenses of the lens unit forms an image on the imaging surface, the imager comprising at least part of an exposure controller that controls an exposure of the imaging surface, the imaging surface being concavely curved with respect to the lens unit.

\* \* \* \* \*