



US011312561B2

(12) **United States Patent**
Murray

(10) **Patent No.:** **US 11,312,561 B2**
(45) **Date of Patent:** **Apr. 26, 2022**

(54) **FLEXIBLE POUCH FOR TWO-COMPONENT PRODUCTS**

USPC 206/219, 220; 383/38, 40
See application file for complete search history.

(71) Applicant: **Pouch Pac Innovations, LLC**,
Sarasota, FL (US)

(56) **References Cited**

(72) Inventor: **R. Charles Murray**, Sarasota, FL (US)

U.S. PATENT DOCUMENTS

(73) Assignee: **Pouch Pac Innovations, LLC**,
Sarasota, FL (US)

3,670,927	A *	6/1972	Hubbard	B65D 25/56
					222/107
4,396,383	A *	8/1983	Hart	A61J 1/2093
					604/404
4,465,488	A *	8/1984	Richmond	A61J 1/2093
					604/414
4,952,068	A *	8/1990	Flint	B01F 5/0602
					206/219
5,431,496	A *	7/1995	Balteau	A61M 1/1668
					383/38
5,928,213	A *	7/1999	Barney	A61J 1/2093
					604/410
6,039,720	A *	3/2000	Wieslander	A61J 1/2093
					206/219
6,186,998	B1 *	2/2001	Inuzuka	B29C 66/4312
					206/219

(*) Notice: Subject to any disclaimer, the term of this patent is extended or adjusted under 35 U.S.C. 154(b) by 0 days.

(21) Appl. No.: **15/360,446**

(22) Filed: **Nov. 23, 2016**

(65) **Prior Publication Data**

US 2017/0144822 A1 May 25, 2017

Related U.S. Application Data

(60) Provisional application No. 62/259,690, filed on Nov. 25, 2015.

(51) **Int. Cl.**

B65D 81/32 (2006.01)
B65D 30/22 (2006.01)
B65D 75/58 (2006.01)
B65D 75/00 (2006.01)

(52) **U.S. Cl.**

CPC **B65D 81/3266** (2013.01); **B65D 31/12** (2013.01); **B65D 75/008** (2013.01); **B65D 75/5805** (2013.01); **B65D 75/5866** (2013.01); **B65D 75/5883** (2013.01)

(58) **Field of Classification Search**

CPC B65D 81/32; B65D 31/12; B65D 75/008; B65D 75/5805; B65D 75/5883; B65D 81/3266; B65D 75/5866

(Continued)

Primary Examiner — J. Gregory Pickett

Assistant Examiner — Jenine Pagan

(74) *Attorney, Agent, or Firm* — Dinsmore & Shohl LLP

(57) **ABSTRACT**

A flexible pouch for two-component products includes a front panel, a back panel and a pair of side seals. An upper compartment is formed between the front panel, the back panel, one of the pair of side seals, an intermediate side seal and a bottom frangible seal. A lower compartment is formed beneath the upper compartment between the front panel and the back panel. A vertical passage extends between the intermediate side seal and another of the pair of side seals from the lower compartment to an opening. Rupture of the bottom frangible seal provides a fluid passageway from the upper compartment to the lower compartment.

17 Claims, 8 Drawing Sheets

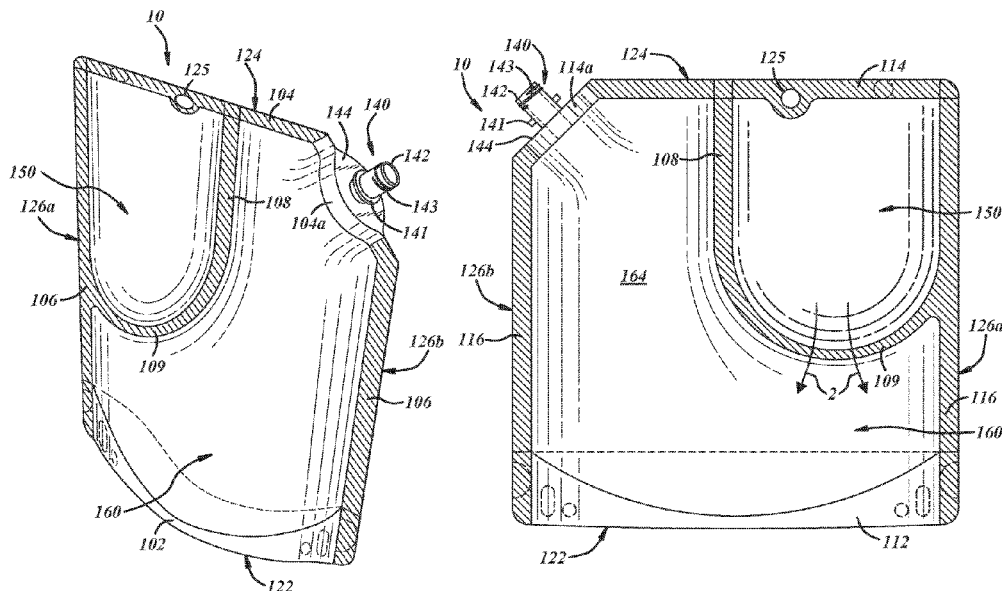

(56)

References Cited

U.S. PATENT DOCUMENTS

6,645,191	B1 *	11/2003	Knerr	A61J 1/2093 604/410	2006/0196784	A1	9/2006	Murray	
7,055,683	B2 *	6/2006	Bourque	B29C 65/76 206/219	2007/0278114	A1 *	12/2007	Kane	B65D 75/5883 206/219
7,306,095	B1 *	12/2007	Bourque	B29C 65/76 206/219	2008/0002918	A1 *	1/2008	Steele	B31B 37/00 383/38
8,118,158	B2 *	2/2012	Igota	A61J 1/2093 206/219	2011/0293202	A1 *	12/2011	Takeda	B65D 33/1691 383/6
8,915,359	B2 *	12/2014	DiLiberto	B65D 81/3272 206/222	2013/0126370	A1 *	5/2013	DiLiberto	B65D 81/3272 206/219
8,960,438	B2	2/2015	Murray		2013/0283736	A1 *	10/2013	VanLoocke	B65B 29/10 53/455
9,320,680	B2 *	4/2016	Schroder	A61J 1/2093	2013/0304016	A1 *	11/2013	Kouno	A61J 1/1475 604/410
9,334,098	B1 *	5/2016	Hughes	B65D 81/3266	2014/0212075	A1 *	7/2014	Cross	B65D 75/5883 383/64
2002/0166779	A1 *	11/2002	Etesse	B65D 75/008 206/219	2014/0319150	A1 *	10/2014	Flank	A61J 1/10 220/529
2003/0049354	A1	3/2003	Murray		2016/0052705	A1	2/2016	Murray	
2006/0127549	A1	6/2006	Murray						

* cited by examiner

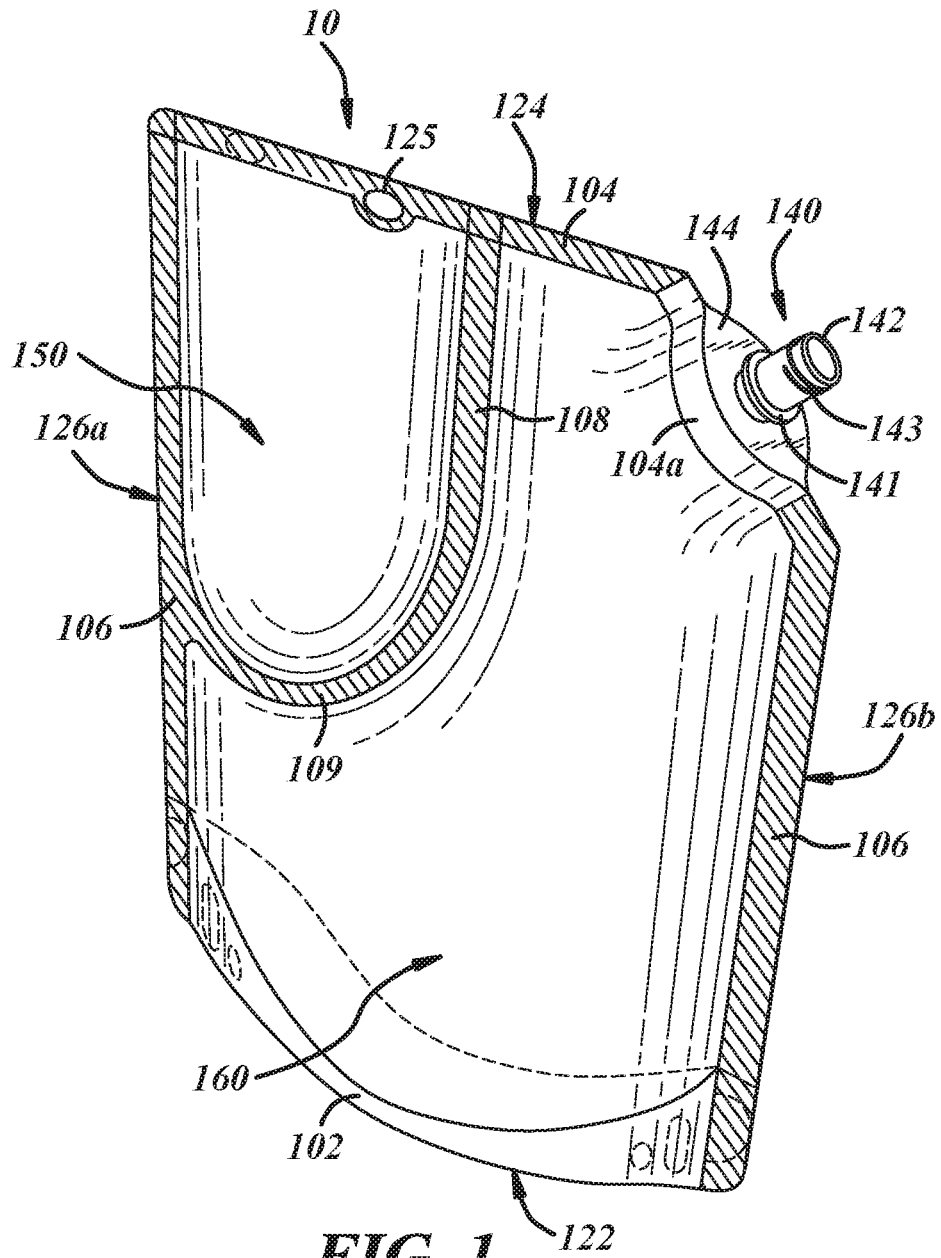

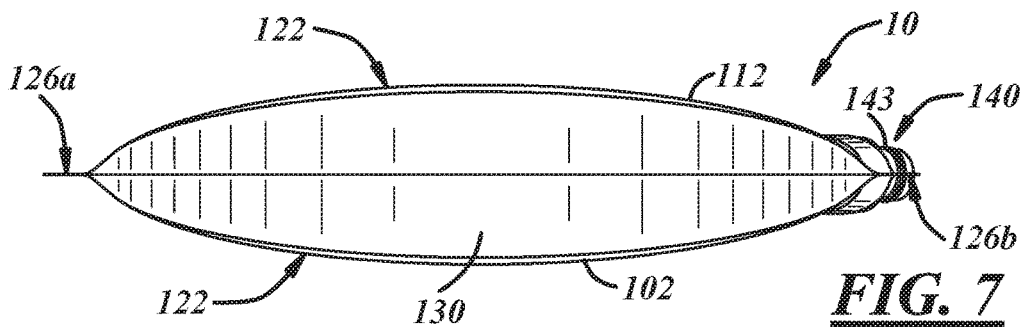
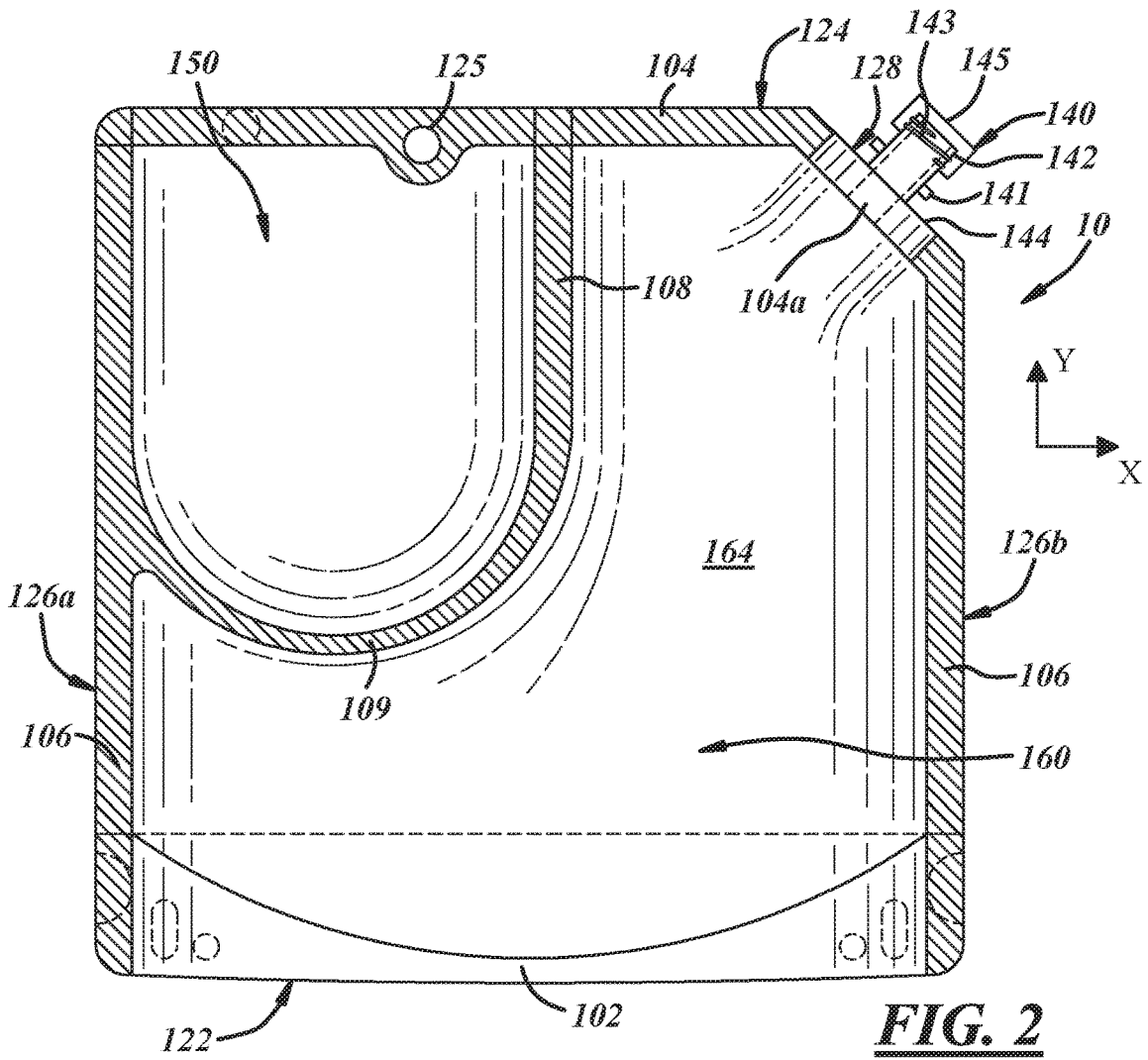
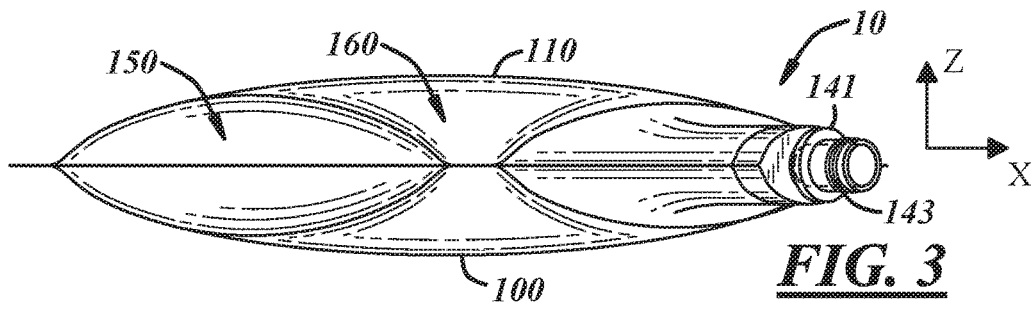

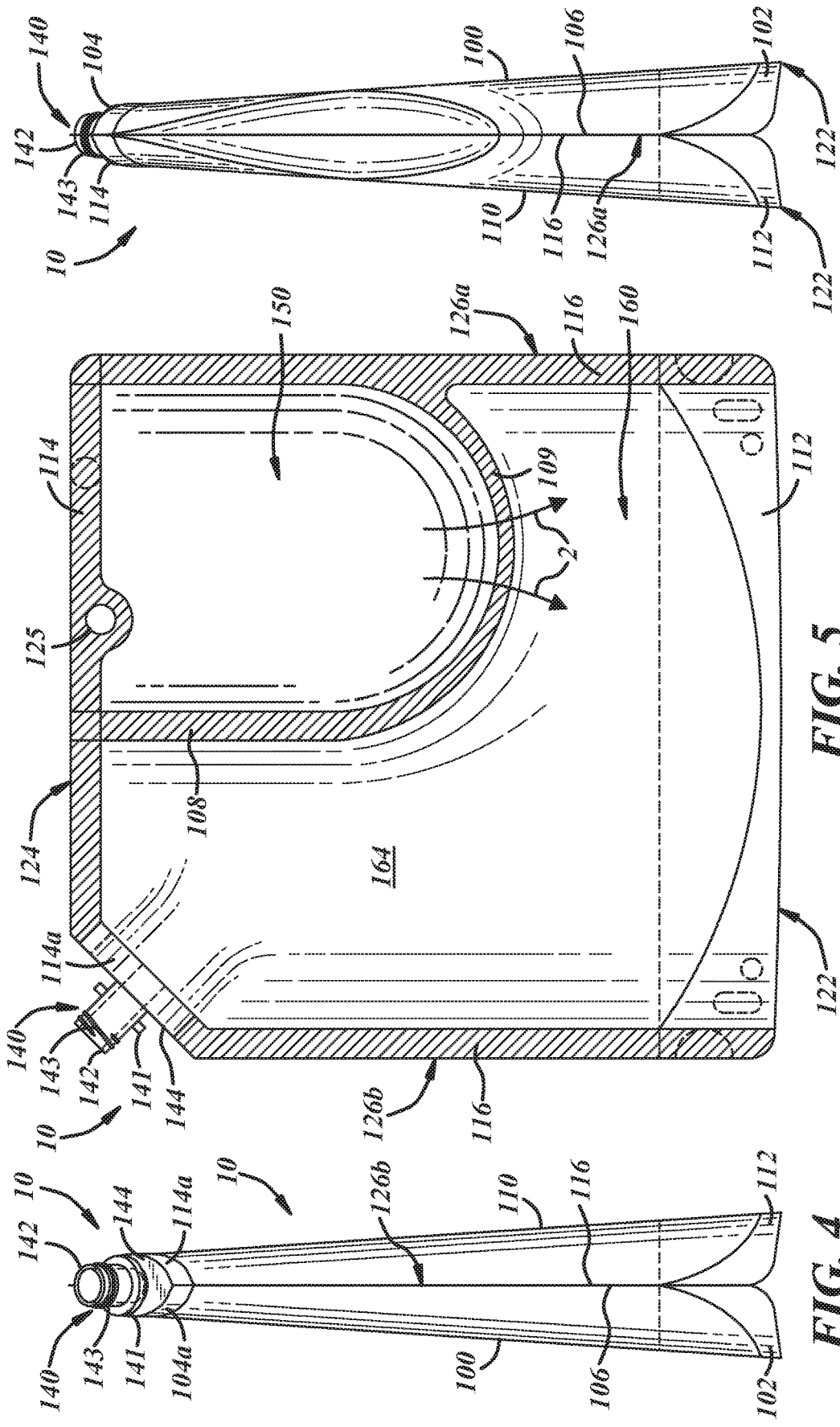

FIG. 4

FIG. 5

FIG. 6

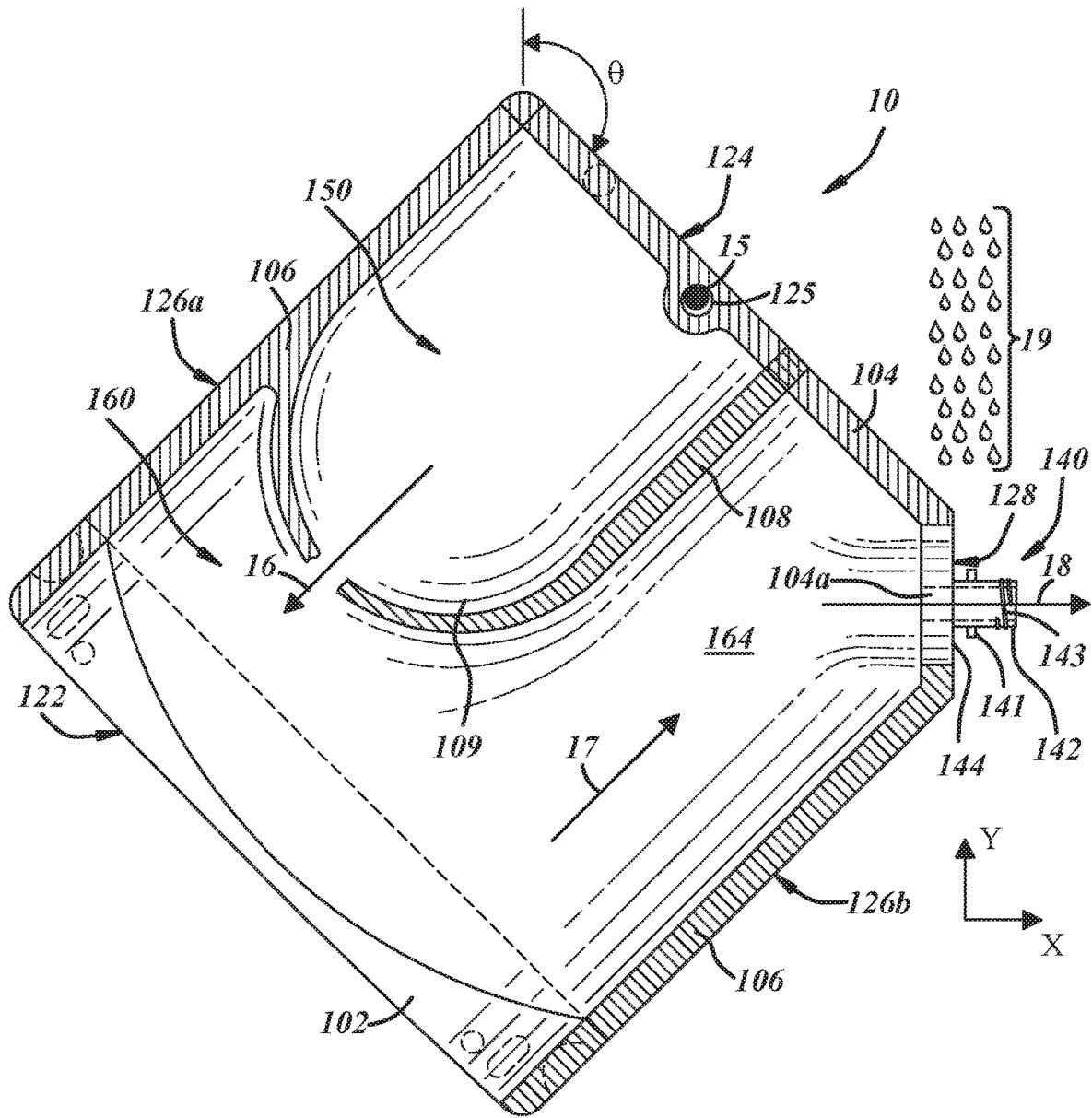

FIG. 8

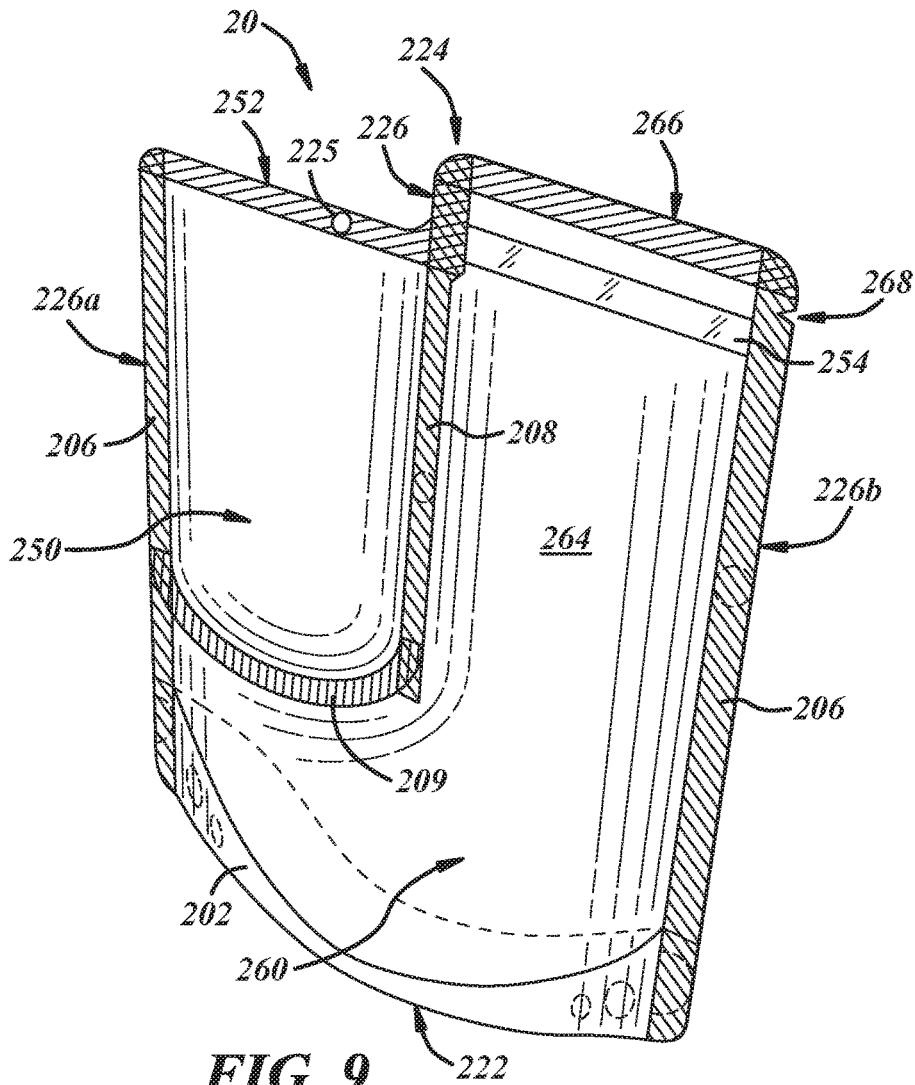

FIG. 9

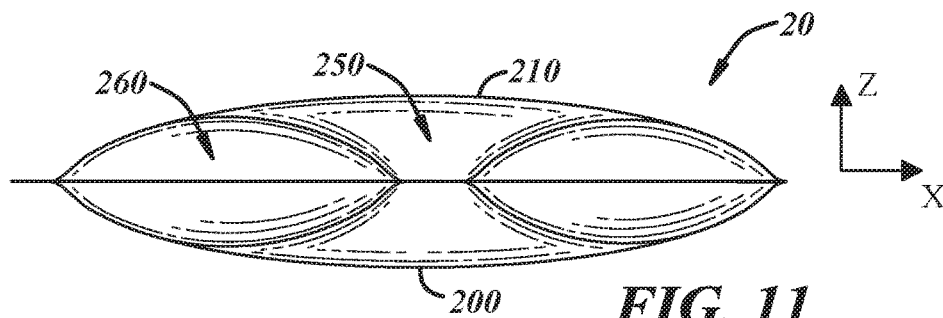
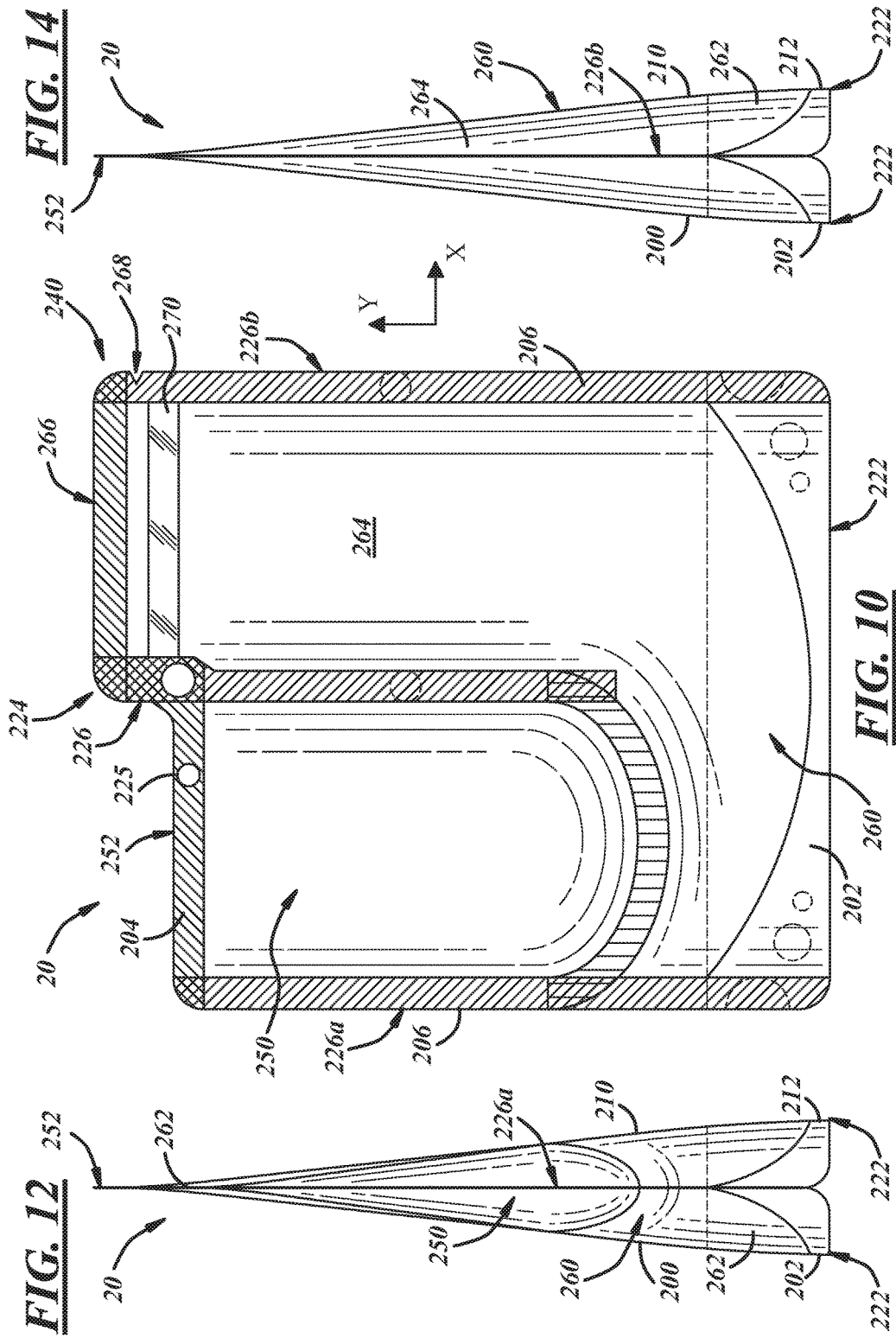

FIG. 11



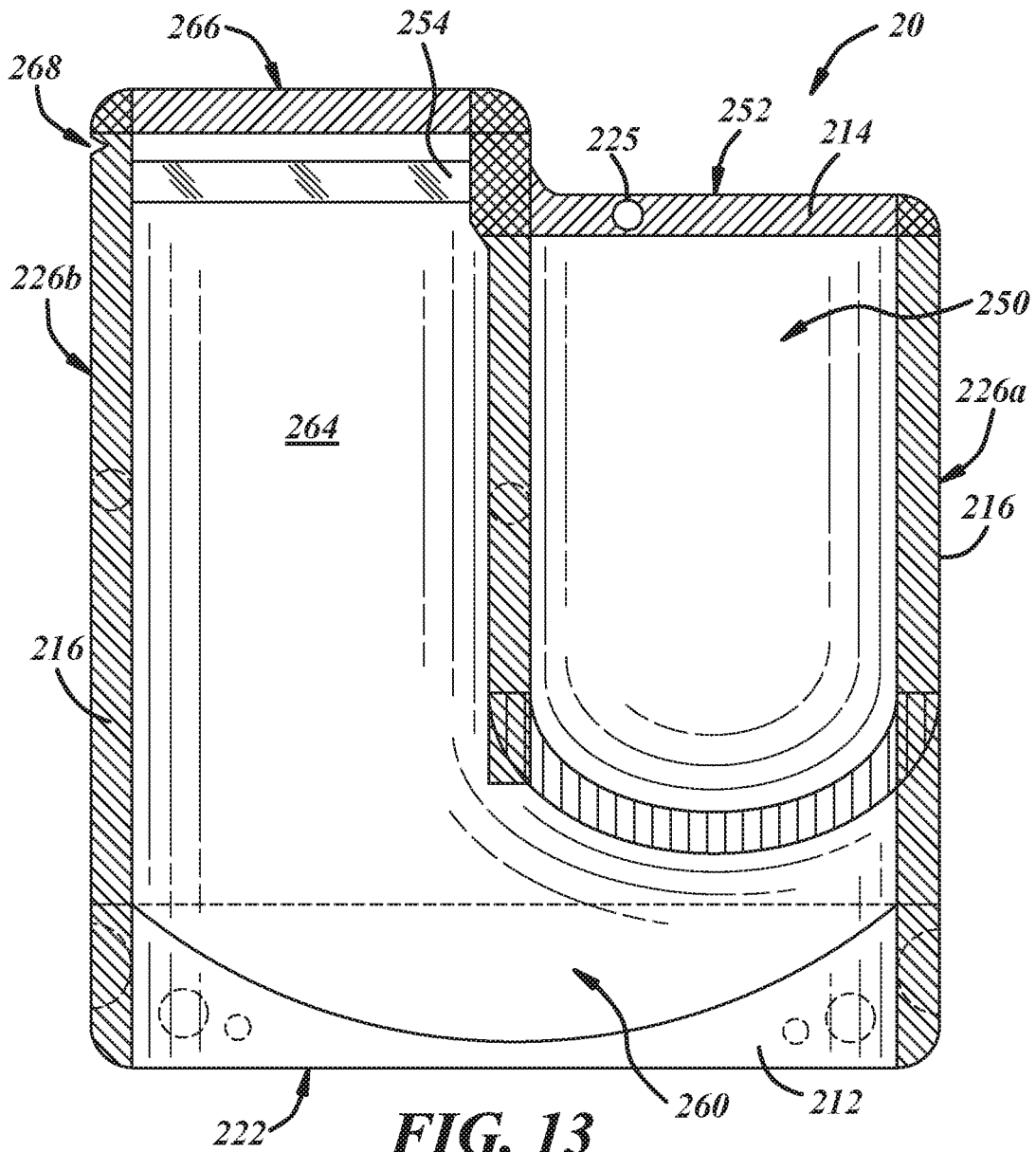

FIG. 13

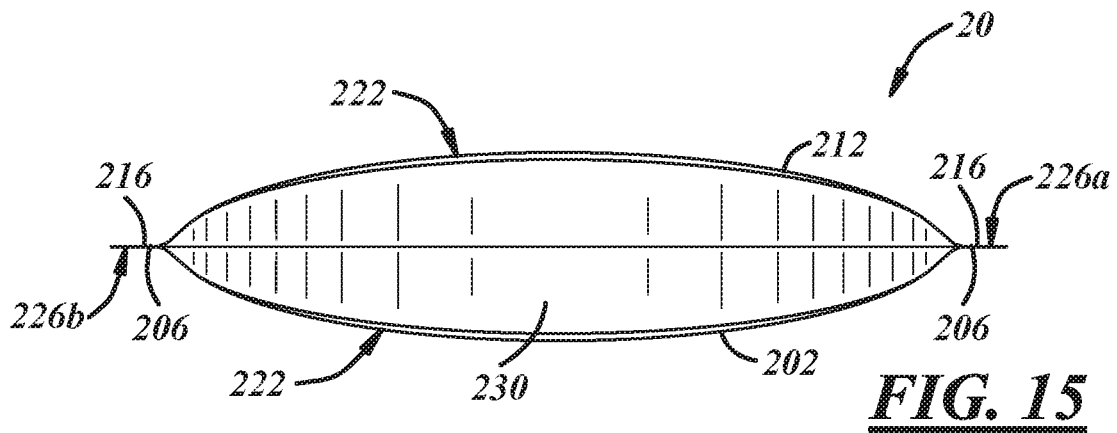

FIG. 15

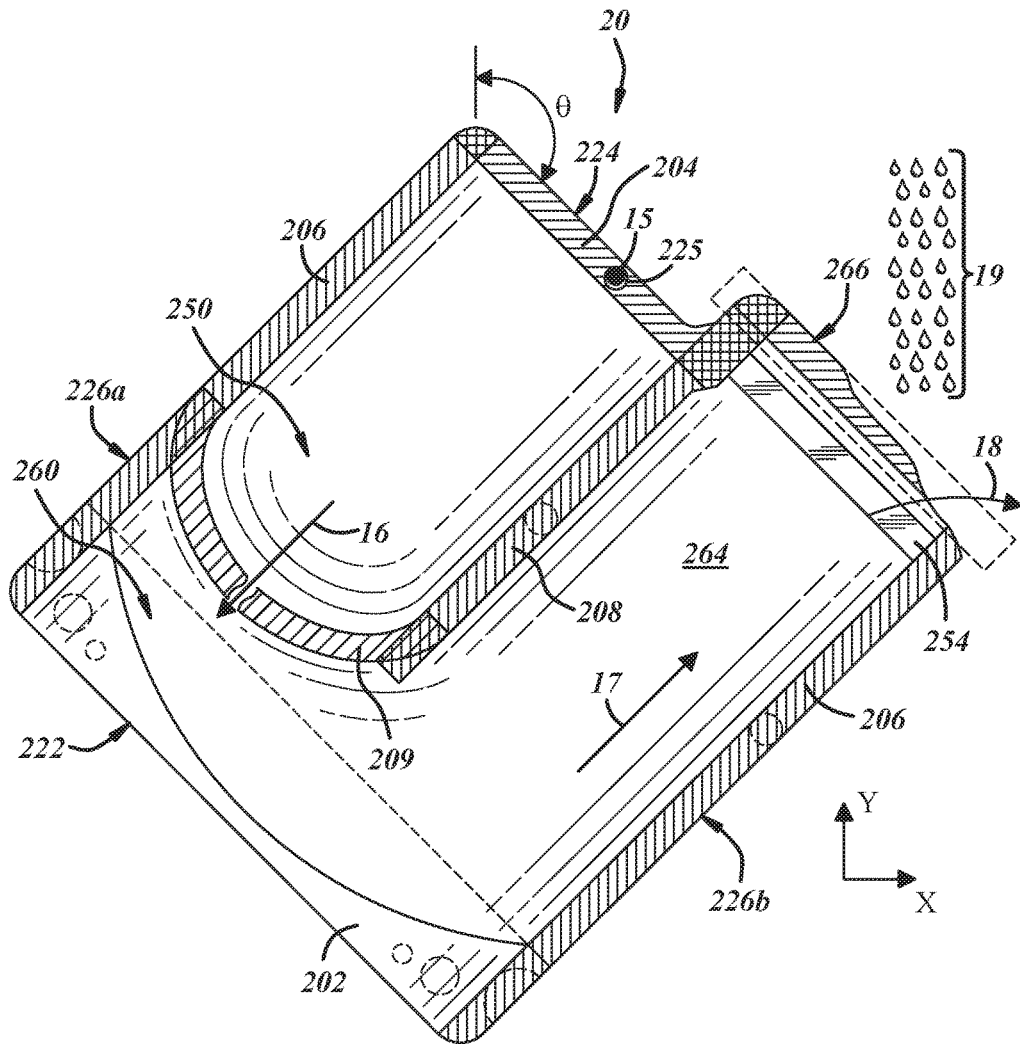

FIG. 16

1

FLEXIBLE POUCH FOR TWO-COMPONENT PRODUCTS**CROSS-REFERENCE TO RELATED APPLICATIONS**

The instant application claims priority to U.S. Provisional Application Ser. No. 62/259,690 filed Nov. 25, 2015, the entire contents of which are incorporated herein by reference.

FIELD OF THE INVENTION

The instant application is directed to a flexible pouch and particularly to a flexible pouch for containing two-component products.

BACKGROUND OF THE INVENTION

Many products have dry components which must be mixed with a liquid to be activated. The dry components may be packaged in a plastic or flexible pouch, e.g., a stand up flexible pouch. Mosquito control products may have dry components including yeast which can be activated upon adding water. The water reacts with the yeast to produce carbon dioxide which can draw mosquitoes to the carbon dioxide fumes and other chemicals used to control the insects. The water must be supplied from an external source measured and poured into the pouch. Such a two or more step procedure may be inconvenient. Accordingly, an improved flexible pouch for two-component products would be desirable.

SUMMARY OF THE INVENTION

A flexible pouch for two-component products includes a front panel, a back panel and a pair of side seals. An upper compartment is formed between the front panel, the back panel, one of the pair of side seals, an intermediate side seal and a bottom frangible seal. A lower compartment is formed beneath the upper compartment between the front panel and the back panel. A vertical passage extends between the intermediate side seal and another of the pair of side seals from the lower compartment to an opening. Rupture of the bottom frangible seal provides a fluid passageway from the upper compartment to the lower compartment.

In embodiments, the intermediate side seal is a permanent seal and the bottom frangible seal extends from the intermediate side seal to the one of the pair of side seals. The bottom frangible seal may provide a funnel shape from the upper compartment to the lower compartment and may be spaced apart from a bottom seal of the lower compartment. An aperture may extend through a top edge portion of the front panel and the back panel. The aperture may be positioned off-center along the top edge portions of the front and back panels such that the flexible pouch rotates to a tilted position when the flexible pouch is hanging from an object extending through the aperture.

In embodiments, a spout fitment is positioned in the opening and sealed between the front panel and the back panel. In other embodiments, a tear-off portion is positioned in the opening and may be used to open the flexible pouch. A strip of reflective tape may be attached to an inner surface of the vertical passage proximate to the opening.

A first product may be present in the upper compartment and a second product present in the lower compartment. Rupture of the bottom frangible seal releases the first

2

product from the upper compartment to come into contact with the second product in the lower compartment such that a third product, e.g., a gas, is formed and flows through the vertical passage and out of the opening.

Additional features and advantages of flexible pouches described herein will be set forth in the detailed description which follows, and in part will be readily apparent to those skilled in the art from that description or recognized by practicing the embodiments described herein, including the detailed description which follows, the claims, as well as the appended drawings.

It is to be understood that both the foregoing general description and the following detailed description describe various embodiments and are intended to provide an overview or framework for understanding the nature and character of the claimed subject matter. The accompanying drawings are included to provide a further understanding of the various embodiments, and are incorporated into and constitute a part of this specification. The drawings illustrate the various embodiments described herein and together with the description serve to explain the principles and operations of the claimed subject matter.

BRIEF DESCRIPTION OF THE DRAWINGS

FIG. 1 is a perspective view of a two-component flexible pouch according to one or more embodiments disclosed and described herein;

FIG. 2 is a side view of the flexible pouch depicted in FIG. 1;

FIG. 3 is a top view of the flexible pouch depicted in FIG. 1;

FIG. 4 is a front view of the flexible pouch depicted in FIG. 1;

FIG. 5 is another side view of the flexible pouch depicted in FIG. 1;

FIG. 6 is a rear view of the flexible pouch depicted in FIG. 1;

FIG. 7 is a bottom view of the flexible pouch depicted in FIG. 1;

FIG. 8 is a side view of the flexible pouch depicted in FIG. 2 hanging in a tilt position according to one or more embodiments disclosed and described herein;

FIG. 9 is a perspective view of a two-compartment flexible pouch according to one or more embodiments disclosed and described herein;

FIG. 10 is a side view of the flexible pouch depicted in FIG. 9;

FIG. 11 is a top view of the flexible pouch depicted in FIG. 9;

FIG. 12 is a rear view of the flexible pouch depicted in FIG. 9;

FIG. 13 is another side view of the flexible pouch depicted in FIG. 9;

FIG. 14 is a front view of the flexible pouch depicted in FIG. 9;

FIG. 15 is a bottom view of the flexible pouch depicted in FIG. 9; and

FIG. 16 is a side view of the flexible pouch depicted in FIG. 9 hanging in a tilt position according to one or more embodiments disclosed and described herein.

DETAILED DESCRIPTION OF THE PREFERRED EMBODIMENTS

Referring to FIGS. 1-7, a flexible pouch for containing two separate products that may be brought into contact with

each other upon rupture of an internal frangible seal is provided. The flexible pouch includes a front panel, a back panel and a pair of side seals. An upper compartment is formed between the front panel, the back panel, one of the pair of side seals and an intermediate side seal positioned between the pair of side seals. A bottom frangible seal may separate the upper compartment from a lower compartment that is formed beneath the upper compartment between the front panel and the back panel. A vertical passage extends between the intermediate side seal and another of the pair of side seals from the lower compartment to an opening. Breaking through or rupturing of the bottom frangible seal provides a fluid passageway from the upper compartment to the lower compartment. A first product contained within the upper compartment may flow into the lower compartment containing a second product when the frangible seal is ruptured. Contact of the first product with the second product may generate or result in the creation of a desired third product. For example and without limitation, the first product may be a liquid, solid or gas, the second product may be a liquid, solid, or gas, and the third product may be a solid, liquid or gas that is formed when the first product comes into contact with the second product. The third product, e.g., a gas, can flow through the vertical passage and out of the opening in order to be released from or exit the flexible pouch.

Still referring to FIGS. 1-7, a two-compartment flexible pouch 10 includes a front panel 100 and a back panel 110. The front panel 100 may have a bottom edge portion 102, a top edge portion 104 and a pair of side edge portions 106 (FIG. 2). The back panel 110 may have a bottom edge portion 112, a top edge portion 114 and a pair of side edge portions 116 (FIG. 5). The front panel 100 may be attached to the back panel 110 with a bottom seal 122, a top seal 124 and a pair of side seals 126a, 126b. In embodiments, a gusset 130 (FIG. 7) can be positioned between the bottom edge portion 102 of the front panel 100 and the bottom edge portion 112 of the back panel 110 such that a stable base for the flexible pouch 10 is provided. That is, the gusset 130 may be attached to the bottom edge portions 102, 112 with the bottom seal 122 such that the flexible pouch 10 can stand or remain upright as depicted in FIGS. 1, 4, and 6.

In embodiments, the bottom seal 122, top seal 124 and pair of side seals 126a, 126b may be formed from a seal, e.g., a heat seal, that joins the bottom edge portions 102, 112 together, the top edge portions 104, 114 together and the side edge portions 106, 116 together. In other embodiments, one or more of the bottom seal 122, top seal 124 and pair of side seals 126a, 126b may be formed from a fold line created by folding a single panel to form the front panel 100 and back panel 110. Accordingly, the term "seal" as used herein refers to a boundary of an interior of the flexible pouch and may be formed by joining a portion of a front panel to a portion of a back panel, e.g., via a heat seal, or in the alternative, may be formed by folding a single panel to form a front panel and a back panel with a fold line there between.

The flexible pouch 10 may include an upper compartment 150 formed between the front panel 100, the back panel 110, one of the pair of side seals 126a, an intermediate side seal 108, and a bottom frangible seal 109. The bottom frangible seal 109 may extend from and between the intermediate side seal 108 to the side seal 126a. The flexible pouch 10 also includes a lower compartment 160 formed beneath the upper compartment 150 between the front panel 100 and the back panel 110. The flexible pouch 10 may also include a vertical passage 164 extending between the intermediate side seal 108 and another of the pair of side seals 126b from the lower

compartment 160 to an opening 140. Rupture of the bottom frangible seal 109 provides a fluid passageway between the upper compartment 150 and the lower compartment 160. The bottom frangible seal 109 is designed and configured to rupture when a predetermined amount of force is applied thereto as described in greater detail below. The intermediate side seal 108 may be a permanent seal designed and configured not to rupture when force applied to the flexible pouch 10 ruptures the bottom frangible seal 109. The bottom frangible seal 109 may have an arcuate shape and provide a funnel shape from the upper compartment 150 to the lower compartment 160. In this manner, a product contained within the upper compartment 150 may fully drain or flow from the upper compartment 150 into the lower compartment 160. Also, the bottom frangible seal may be spaced apart from the bottom seal 122 of the flexible pouch 10 such that sufficient space or volume is provided for a product contained within the upper compartment 150 to flow into the lower compartment 160. For example, and without limitation, the bottom frangible seal 109 may be spaced apart from the bottom seal 122 between about 25% to about 50% of the overall height (Y direction) of the flexible pouch 10.

In embodiments, an aperture 125 extends through the top seal 124. The position of the aperture 125 along the top seal 124 is off-center along the width (X direction) of the flexible pouch 10. The off-center position of the aperture 125 along the width (X direction) of the top seal 124 is configured for the flexible pouch 10 to rotate from a stand-up position as depicted in FIG. 2 to a tilt position as depicted in FIG. 8 when the flexible pouch 10 is hung from an object 15 such as a rod, pin, nail, etc., extending through the aperture 125. That is, hanging the flexible pouch 10 with the object 15 extending through the aperture 125 results in the flexible pouch 10 rotating in a tilt position such that the opening 140 rotates in a downwardly direction (-Y direction). In embodiments, the opening 140 rotates in a downwardly direction between about 15 degrees to about 75 degrees. In other embodiments, the opening 140 rotates in a downwardly direction between about 30 degrees to about 60 degrees. Rotation of the flexible pouch 10 in a downwardly direction may prevent objects 19 from falling within the opening 140 as described in greater detail below.

In embodiments, a spout fitment 142 is positioned within the opening 140. The spout fitment 142 may have a flange 141, threads 143 and a base portion 144 that is sealed to an opening edge 104a of the front panel 100 and an opening edge 114a of the back panel 110 with a seal 128. A cap 145 can be attached to the spout fitment 142 and removed once the bottom frangible seal 109 has been ruptured and the first product has come into contact with the second product. In embodiments the cap 145 has threads (not shown) that engage the threads 143 of the spout fitment 142 for securement of the cap 145 to the spout fitment 142. The spout fitment 142 with the cap 145 allows for storage of the flexible pouch 10 and any products that may be contained within the upper compartment 150 and the lower compartment 160.

The flexible pouch 10 may be formed and filled by attaching the front panel 100 to the back panel 110 with the bottom seal 122 and side seals 126a, 126b using a flexible pouch manufacturing machine (not shown). The intermediate side seal 108 and bottom frangible seal 109 may be formed such that the upper compartment 150, lower compartment 160 and vertical passage 164 are provided. The upper compartment 150 may be filled with a desired quantity of a first product, for example and without limitation a liquid or a solid, at a first filling station on the flexible pouch

manufacturing machine. The top seal **124** may be formed across an upper portion of the flexible pouch **10** such that the first product is sealed within the upper compartment **150**. The flexible pouch may be moved to a second filling station where a diving tube (not shown) is inserted into the vertical passage **164** and/or lower compartment **160** through the spout fitment **142**. The lower compartment **160** may be filled with a desired amount of a second product, for example and without limitation a liquid or a solid, through the diving tube and the cap **145** may be attached to the spout fitment **142** to seal the second product within the lower compartment **160**.

Referring now to FIG. **8**, in use the flexible pouch **10** may include a first product contained within the upper compartment **150** and a second product contained in the lower compartment **160**. The first product may be a solid such as, without limitation, yeast, and the second product may be a liquid such as, without limitation, water. The bottom frangible seal **109** is ruptured by applying a compressive force on the upper compartment **150**. For example and without limitation, grasping and rolling the upper compartment **150** from the top seal **124** towards the bottom frangible seal **109** may create an internal pressure within the upper compartment **150** that exerts a force on the bottom frangible seal **109**. Upon reaching a predefined force that is greater than a sealing force provided by the bottom frangible seal **109**, the bottom frangible seal **109** ruptures which forms a fluid passageway from the upper compartment **150** to the lower compartment **160**. Once the fluid passageway from the upper compartment **150** to the lower compartment **160** is created, the first product contained within the upper compartment **150** flows from the upper compartment **150** into the lower compartment **160** as depicted by arrow **16** and comes into contact and/or mixes with the second product and a third product is produced. The third product, e.g., a gas such as and without limitation carbon dioxide, exits the flexible pouch **10** by flowing up through the vertical passage **164** as depicted by arrow **17** and out through the opening **140** as depicted by arrow **18**. The third product may attract insects such as, and without limitation, mosquitoes to the flexible pouch **10**. The flexible pouch **10** can be hung (suspended) with the object **15** extending through the aperture **125** and the opening **140** rotates downwardly as described above. Upon rotating to a downward position, objects such rain, leaves, etc. are prevented from falling within the opening **140**, thereby protecting the contents within the flexible pouch **10**.

Referring now to FIGS. **9-15**, another embodiment of a two-compartment flexible pouch is shown generally at reference numeral **20**. The flexible pouch **20** includes a front panel **200** and a back panel **210**. The front panel **200** may have a bottom edge portion **202**, a top edge portion **204** and a pair of side edge portions **206** (FIG. **10**). The back panel **210** may have a bottom edge portion **212**, a top edge portion **214** and a pair of side edge portions **216** (FIG. **13**). The front panel **200** may be attached to the back panel **210** with a bottom seal **222**, a top seal **224** and a pair of side seals **226a**, **226b**. In embodiments, a gusset **230** (FIG. **15**) can be positioned between the bottom edge portion **202** of the front panel **200** and the bottom edge portion **212** of the back panel **210** such that a stable base for the flexible pouch **20** is provided. That is, the gusset **230** may be attached to the bottom edge portions **202**, **212** with the bottom seal **222** such that the flexible pouch **20** can stand or remain upright as depicted in FIGS. **9**, **12**, and **14**.

In embodiments, the bottom seal **222**, top seal **224** and pair of side seals **226a**, **226b** may be formed from a seal, e.g., a heat seal, that joins the bottom edge portions **202**, **212**

together, the top edge portions **204**, **214** together and the side edge portions **206**, **216** together. In other embodiments, one or more of the bottom seal **222**, top seal **224** and pair of side seals **226a**, **226b** may be formed from a fold line created by folding a single panel to form the front panel **200** and the back panel **210**.

The flexible pouch **20** may include an upper compartment **250** formed between the front panel **200**, the back panel **210**, one of the pair of side seals **226a**, an intermediate side seal **208**, and a bottom frangible seal **209**. The bottom frangible seal **209** may extend from and between the intermediate side seal **208** to the side seal **226a**. An upper compartment top seal **252** may extend across an upper portion of the upper compartment **250**. The flexible pouch **20** also includes a lower compartment **260** formed beneath (-Y direction) the upper compartment **250** between the front panel **200** and the back panel **210**. The flexible pouch **20** may also include a vertical passage **264** extending between the intermediate side seal **108** and another of the pair of side seals **226b** from the lower compartment **260** to an opening **240**. A vertical passage top seal **266** may extend across an upper portion of the vertical passage **264**. The vertical passage top seal **266** may be positioned above (+Y direction) the upper compartment top seal **252** as depicted in FIGS. **9**, **10**, and **13**. A vertical seal **226** may extend from the upper compartment top seal **252** to the vertical passage top seal **266**. Rupture of the bottom frangible seal **209** provides a fluid passageway between the upper compartment **250** and the lower compartment **260**. The bottom frangible seal **209** is designed and configured to rupture when a predetermined amount of force is applied thereto as described in greater detail below. The intermediate side seal **208** may be a permanent seal designed and configured not to rupture when force applied to the flexible pouch **20** ruptures the bottom frangible seal **209**. The bottom frangible seal **209** may have an arcuate shape and provide a funnel shape from the upper compartment **250** to the lower compartment **260**. In this manner, a product contained within the upper compartment **250** may fully drain or flow from the upper compartment **250** into the lower compartment **260**. Also, the bottom frangible seal **209** may be spaced apart from the bottom seal **222** of the flexible pouch **20** such that sufficient space or volume is provided for a product contained within the upper compartment **250** to flow into the lower compartment **260**. For example, and without limitation, the bottom frangible seal **209** may be spaced apart from the bottom seal **222** between about 25% to about 50% of the overall height (Y direction) of the flexible pouch **20**.

In embodiments, an aperture **225** extends through the top seal **224**. The position of the aperture **225** along the top seal **224** is off-center along the width (X direction) of the flexible pouch **20**. The off-center position of the aperture **225** along the width of the top seal **224** is configured for the flexible pouch **20** to rotate from a stand-up position as depicted in FIG. **10** to a tilt position as depicted in FIG. **16** when the flexible pouch **20** is hung from an object **25** such as a rod, pin, nail, etc., extending through the aperture **225**. That is, hanging the flexible pouch **20** with the object **25** extending through the aperture **225** results in the flexible pouch **20** rotating in a tilt position such that the opening **240** rotates in a downwardly direction (-Y direction). In embodiments, the opening **240** rotates in a downwardly direction between about 15 degrees to about 75 degrees. In other embodiments, the opening **240** rotates in a downwardly direction between about 30 degrees to about 60 degrees. Rotation of the

flexible pouch **20** in a downwardly direction may prevent objects **19** from falling within the opening **240** as described in greater detail below.

In embodiments, the opening **240** includes the vertical passage top seal **266** and a tear-away notch **268** within the side seal **226b**. The tear-away notch **268** affords for the vertical passage top seal **266** to be at least partially removed from the flexible pouch **20** such that a fluid passageway from the vertical passage **264** to an exterior of the flexible pouch **20** is provided. A reflective tape **270** may be attached to an inner surface of the vertical passage **264**. In embodiments, the reflective tape **270** may attract insects to the opening **240**. The vertical passage top seal **266** may be removed once the bottom frangible seal **209** has been ruptured and the first product has come into contact with the second product. The vertical passage top seal **266** allows for storage of the flexible pouch **20** and any products that may be contained within the upper compartment **250** and the lower compartment **260**.

Referring now to FIG. **16**, in use the flexible pouch **20** may include a first product contained within the upper compartment **250** and a second product contained in the lower compartment **260**. The first product may include a solid such as, without limitation, yeast, and the second product may include a liquid such as, without limitation, water. The bottom frangible seal **209** is ruptured by applying a compressive force on the upper compartment **150**. For example and without limitation, grasping and rolling the upper compartment **250** from the top seal **224** towards the bottom frangible seal **209** may create an internal pressure within the upper compartment **250** that exerts a force on the bottom frangible seal **209**. Upon reaching a predefined force that is greater than a sealing force provided by the bottom frangible seal **209**, the bottom frangible seal **209** ruptures a fluid passageway from the upper compartment **250** to the lower compartment **260** is created. Once the fluid passageway from the upper compartment **250** to the lower compartment **260** is created, the first product contained within the upper compartment **250** flows from the upper compartment **250** into the lower compartment **260** as depicted by arrow **16** and comes into contact and/or mixes with the second product and a third product is produced. A user may grasp the side seal **226b** proximate the tear-away notch **268**, grasp the upper seal proximate the tear-away notch **268** and upon pulling on the vertical passage top seal **266** in a direction away from the side seal **226b** (-X direction) remove at least a portion of the vertical passage top seal **266** as depicted in FIG. **16**. The third product, e.g., a gas such as without limitation carbon dioxide, exits the flexible pouch **20** by flowing up through the vertical passage **264** and out through the opening **240** after the vertical passage top seal **266** has been at least partially removed from the flexible pouch **20**. The third product may attract insects such as, and without limitation, mosquitoes to the flexible pouch **20**. The flexible pouch **20** can be hung (suspended) with the object **15** extending through the aperture **225** and the opening **240** rotates downwardly as described above. The reflective tape **270** may be visible from outside the flexible pouch **20** and may assist in attracting insects such as, and without limitation, mosquitoes to the flexible pouch **20**. Upon rotating to a downward position, the opening **240** is at least partially protected from objects such as rain, leaves, etc. falling and entering the opening **240**, thereby protecting the contents within the flexible pouch **20**.

Based on the foregoing, it should now be understood that the flexible pouches and methods described herein can be used to for two-component products that may be brought

into contact with each other to produce a third product. The use of the flexible pouches provides an upper compartment for containing a first product and a lower compartment for containing a second product. A frangible seal is positioned between the upper compartment and the lower compartment and when the frangible seal is broken, e.g., ruptured, a fluid passage way is formed between the upper compartment and the lower compartment. The fluid passageway allows the first product to flow from the upper compartment to the lower compartment and come into contact with the second product. Contact of the first product with the second product may generate or result in the creation of a desired third product. The third product may be allowed to escape of exit the flexible pouch through an opening by flowing from the lower compartment through a vertical passage extending from the lower compartment to the opening.

It will be apparent to those skilled in the art that various modifications and variations can be made to the embodiments described herein without departing from the spirit and scope of the claimed subject matter. Thus it is intended that the specification cover the modifications and variations of the various embodiments described herein provided such modification and variations come within the scope of the appended claims and their equivalents.

The invention claimed is:

1. A flexible pouch comprising:

a front panel and a back panel;

a pair of side seals;

a permanent intermediate side seal and an arcuate bottom frangible seal defining an upper compartment formed between the front panel, the back panel, and one of the pair of side seals, the permanent intermediate side seal disposed between the pair of side seals, the bottom frangible seal extending between the permanent intermediate side seal and the one of the pair of side seals, the bottom frangible seal is continuously arcuate and is curved downwardly extending from the permanent intermediate side seal and the one of the pair of side seals;

a lower compartment formed beneath the upper compartment between the front panel and the back panel; and a vertical passage extending between the permanent intermediate side seal and another of the pair of side seals from the lower compartment to an opening,

wherein rupture of the bottom frangible seal defines a funnel that provides a fluid passageway from the upper compartment to the lower compartment; and

wherein a portion of the arcuate bottom frangible seal ruptures to define the funnel by applying a compressive force on the upper compartment and the permanent intermediate side seal does not rupture when the compressive force is applied on the upper compartment.

2. The flexible pouch of claim 1, wherein the bottom frangible seal extends from the permanent intermediate side seal.

3. The flexible pouch of claim 1, wherein the bottom frangible seal provides a funnel shape from the upper compartment to the lower compartment.

4. The flexible pouch of claim 1, wherein the bottom frangible seal is spaced apart from the bottom seal.

5. The flexible pouch of claim 1, further comprising an aperture extending through a top edge portion of the front panel and the back panel, wherein the aperture is positioned off-center along the top edge portion such that the flexible pouch rotates to a tilted position when the flexible pouch is hanging from an object extending through the aperture.

9

6. The flexible pouch of claim 1, further comprising a spout fitment positioned in the opening and attached between the front panel and the back panel.

7. The flexible pouch of claim 1, further comprising a tear-off portion positioned in the opening.

8. The flexible pouch of claim 7, further comprising a strip of reflective tape proximate the tear-off portion on an interior surface of at least one of the front panel and the back panel.

9. The flexible pouch of claim 1, wherein the one of the pair of side seals is a permanent seal.

10. A flexible pouch comprising:

a front panel, a back panel, and two compartments for containing two products between a pair of side seals, the front panel and the back panel, the two compartments comprising:

an upper compartment formed between the front panel, the back panel, one of the pair of side seals, a permanent intermediate side seal positioned between the pair of side seals and an arcuate bottom frangible seal, the arcuate bottom frangible seal is continuously arcuate and is curved downwardly extending from the permanent intermediate side seal and one of the pair of side seals;

a lower compartment formed beneath the upper compartment between the front panel, the back panel, the bottom frangible seal and a bottom seal; and

a vertical passage formed between the front panel, the back panel and another of the pair of side seals, the vertical passage extending between the permanent intermediate side seal and the another of the pair of side seals from the lower compartment to an opening;

10

wherein a portion of the arcuate bottom frangible seal ruptures to define a funnel that provides a fluid passageway from the upper compartment to the lower compartment by applying a compressive force on the upper compartment and the permanent intermediate side seal does not rupture when the compressive force is applied on the upper compartment.

11. The flexible pouch of claim 10, wherein the bottom frangible seal is spaced apart from the bottom seal.

12. The flexible pouch of claim 10, wherein the bottom frangible seal provides a funnel shape from the upper compartment to the lower compartment.

13. The flexible pouch of claim 10, further comprising a spout fitment positioned in the opening and attached between the front panel and the back panel.

14. The flexible pouch of claim 10, further comprising a tear-off portion positioned in the opening.

15. The flexible pouch of claim 14, further comprising a strip of reflective tape attached to an interior surface of the vertical passage proximate the opening.

16. The flexible pouch of claim 10, wherein the one of the pair of side seals is a permanent seal.

17. The flexible pouch of claim 10, further comprising an aperture extending through a top seal, wherein the aperture is positioned off-center along the top seal such that the flexible pouch rotates to a tilted position when the flexible pouch is hanging from an object extending through the aperture.

* * * * *