

(12) INTERNATIONAL APPLICATION PUBLISHED UNDER THE PATENT COOPERATION TREATY (PCT)

(19) World Intellectual Property
Organization

International Bureau

(43) International Publication Date
06 December 2018 (06.12.2018)



(10) International Publication Number
WO 2018/220639 A1

(51) International Patent Classification:
F16D 65/38 (2006.01) F16D 65/60 (2006.01)

(21) International Application Number:
PCT/IN2018/050232

(22) International Filing Date:
18 April 2018 (18.04.2018)

(25) Filing Language: English

(26) Publication Language: English

(30) Priority Data:
201741019126 31 May 2017 (31.05.2017) IN

(61) Related by addition to earlier application or grant:
IN 201741019126 (POA)
Filed on 31 May 2017 (31.05.2017)

(71) Applicant: MADRAS ENGINEERING INDUSTRIES
PRIVATE LIMITED [IN/IN]; C-6, Industrial Estate, Am-
battur, Chennai 600018 (IN).

(72) Inventors: GUNASEKARAN, Vivekanandan; 5&6 Sid-
co Industrial Estate, Maraimalai Nagar, Chengalpattu
Taluk, Kancheepuram District, Chengalpattu 603209 (IN).
SIVARAM, Sriram; Madras Engineering Industries Pvt.
Ltd, C-6, Industrial Estate, Ambattur, Chennai 600058 (IN).

(81) Designated States (unless otherwise indicated, for every
kind of national protection available): AE, AG, AL, AM,
AO, AT, AU, AZ, BA, BB, BG, BH, BN, BR, BW, BY, BZ,
CA, CH, CL, CN, CO, CR, CU, CZ, DE, DJ, DK, DM, DO,
DZ, EC, EE, EG, ES, FI, GB, GD, GE, GH, GM, GT, HN,
HR, HU, ID, IL, IN, IR, IS, JO, JP, KE, KG, KH, KN, KP,
KR, KW, KZ, LA, LC, LK, LR, LS, LU, LY, MA, MD, ME,
MG, MK, MN, MW, MX, MY, MZ, NA, NG, NI, NO, NZ,
OM, PA, PE, PG, PH, PL, PT, QA, RO, RS, RU, RW, SA,
SC, SD, SE, SG, SK, SL, SM, ST, SV, SY, TH, TJ, TM, TN,
TR, TT, TZ, UA, UG, US, UZ, VC, VN, ZA, ZM, ZW.

(84) Designated States (unless otherwise indicated, for every
kind of regional protection available): ARIPO (BW, GH,

GM, KE, LR, LS, MW, MZ, NA, RW, SD, SL, ST, SZ, TZ,
UG, ZM, ZW), Eurasian (AM, AZ, BY, KG, KZ, RU, TJ,
TM), European (AL, AT, BE, BG, CH, CY, CZ, DE, DK,
EE, ES, FI, FR, GB, GR, HR, HU, IE, IS, IT, LT, LU, LV,
MC, MK, MT, NL, NO, PL, PT, RO, RS, SE, SI, SK, SM,
TR), OAPI (BF, BJ, CF, CG, CI, CM, GA, GN, GQ, GW,
KM, ML, MR, NE, SN, TD, TG).

Declarations under Rule 4.17:

- as to applicant's entitlement to apply for and be granted a patent (Rule 4.17(ii))
- as to the applicant's entitlement to claim the priority of the earlier application (Rule 4.17(iii))
- of inventorship (Rule 4.17(iv))

Published:

- with international search report (Art. 21(3))

(54) Title: AN AUTOMATIC SLACK ADJUSTER

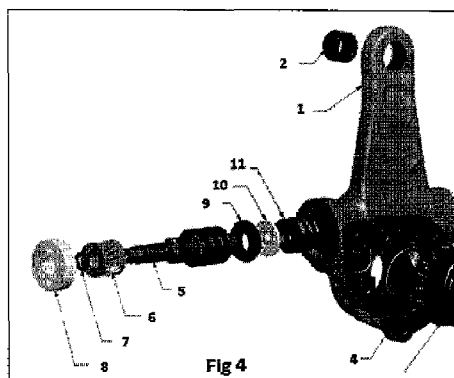

(57) Abstract: The invention is for automatic slack adjuster for an automobile with a housing having an aperture for receiving a brake cam shaft comprising of a worm gear coaxially mounted within the said housing aperture and configured to coaxially engage the brake cam shaft, such that the said worm gear and said cam shaft rotating together about a first axis. The arrangement has a bore with a single open end for receiving a worm clutch shaft. The said worm clutch shaft is mounted in the said housing to rotate about a second axis, which is perpendicular to first axis. The invention has only one side opening. The thrust load from the worm shaft is transferred through the thrust bush through the main housing of the assembly.

WO 2018/220639 A1

TITLE: AN AUTOMATIC SLACK ADJUSTER**FIELD OF INVENTION:**

This invention relates to an automatic slack adjuster and an improved automatic slack adjuster

PRIOR ART:S-ASA Function - General:

Self-setting Automatic Slack Adjuster (S-ASA) design works on 'clearance sensing' principle. Meaning, as the brake lining wears out due to application of brake, S-ASA adjusts the clearance between the brake lining & the drum and maintains it to the pre-determined value. This automatic adjustment helps to maintain the brake effective all the time.(Refer Fig.1)

Conventionally, the Automatic slack adjuster design and construction remains same for Light duty vehicle (Typically 9 Ton GVW) to Medium (Typically 16 Ton GVW), Heavy duty vehicle (Typically 25 Ton and above). Only the spline (indicated in Fig 2) size of the worm wheel is changed to suit the mating cam shaft. For Light duty vehicle, the conventional existing Auto slack adjuster is 'over designed' and bulky.

OBJECT OF THE INVENTION:

1. The object of the invention is a design which is compact and tailor-made to meet the brake cam shaft torque requirement of the Light duty vehicles.
2. A design which is improved for better endurance life – the sealing requirements were reduced in this design (eliminated one side port opening in the housing).
3. An Assembly process which is simpler. All components are assembled in only two axial directions whereas in conventional design, it happens in three directions.

4. A Lighter means compared to the existing ones in use. That means each brake or wheel end is made lighter by at least 1 kg which is a significant improvement for power-weight ratio.

DESCRIPTION OF THE INVENTION:

Construction of the slack adjuster as per the invention is illustrated in Fig 2

Order of Assembly of the components is disclosed in Fig 2B

FRONT side

- Tail Bush is assembled.
- Worm Gear, along with 2 Sealing Rings on either side, is placed.

LEFT side

- Heavy coil spring placed in position. Then spring seat and then Thrust bush.
- Worm Shaft along with Clutch Worm Gear and Sealing Ring are assembled together on one side of the body. Finally Bearing Retainer is assembled. Kindly note, the bearing retainer threads are coated with 'locking compound' and hence no need for Rivet locking.

Again from FRONT side

- Now again on front side of the body, Pinion & Ratchet Assembly is placed. Then Gasket along with Cover Plate Assembly is mounted to head portion of the body using 6 Counter Sunk Screws.

Fig 3 illustrates that one side remain closed (no component assembly)

No components assembly from Right side in this LT S-ASA and hence we avoid one side opening and potential leak path. In normal existing S-ASA, there is an opening on Right side and components are assembled from that end also.

Though one side opening in the housing is eliminated, still the functional requirement has been met in the LT S-ASA by addition of a component called 'Thrust Bush' as shown in the below image. (Fig 4)

The thrust load from the worm shaft (5) is transferred through the 'Thrust Bush (9)' to the main housing (1).

WORKING PRINCIPLE OF THE INVENTION:

WORKING PRINCIPLE OF SASA (LT)

Fig 5 is Illustration of foundation on brake and showing the movement of slack adjuster during braking with excess clearance B

Description with respect to Fig 5:

- A.** The normal preset running clearance **A** for which no adjustment should be made;
- B.** The excess clearance **B**, when lining and drum wear and for which adjustment should be made
- C.** The elasticity of the breaking system **C** which is caused by variable brake load, rum expansion and component flexibility, for which no adjustment should be made

Fig 6 is illustration of starting position of SASA

Description with respect to Fig 6 and Fig 7:

The control arm (20) of the S-ASA is fixed to the anchor bracket in a position where suitable location is available on the vehicle for fastening the control arm fixing position (20'). During the initial brake setting, the control worm screw (13.5) is getting positioned with a gap between pawl housing (13.2) and control worm screw (13.5) by the torsion spring (13.9) load. This is to determine the pre-set clearance that will be maintained between brake lining and the brake drum.

Fig 8 is the illustration of rotation through clearance zone A

Fig 9 is the illustration of Brakes application –thro' clearance zone

Description of Fig 8 and Fig 9

During the initial brake application, the pinion & ratchet (13.1) is rotated by the control arm assembly (17,19-22), due to the movement of the S-ASA body and the pawl housing (13.2) is also rotated along with pinion & ratchet (13.1) up to the preset gap between the stepped faces of control worm screw (13.5) and pawl housing (13.2) to ensure predetermined clearance stroke. Simultaneously the worm wheel (14) is rotated in the counter clockwise direction along with Automatic Slack Adjuster body (1); in turn the S camshaft engaged with the worm wheel spline (14') is rotated to lift the brake lining towards the brake drum.

Fig 10 and 11 is the illustration of rotation through the excess clearance zone B

Description of Fig 10 and Fig 11

When there is excess clearance due to wear in drum and lining, the lining does not touch the brake drum. During the further rotation (after passing through clearance stroke cycle) of the ratchet mechanism in the pinion & ratchet (13.1), overrides against pawl spring (13.4) load and gets a new engagement with the pawl (13.3) fixed to the pawl housing (13.2).

This is because control worm screw (13.5) is prevented from rotation by clutch worm gear (5) due to excess friction on the clutch worm gear (5) with its serration (5') fully engaged on the worm shaft serration (6").

Fig 12 and 13 is the illustration of rotation into the elasticity angle C

Description of Fig 12 and Fig 13

Once the brake lining engages the brake drum, the counter force increases and worm shaft (6) moves axially compressing the heavy compression spring (10). Clutch is disengaged as the serrated portion of worm shaft (6") is moved away from the clutch worm wheel serration (5').

Fig 14 and 15 is the illustration of rotation through elasticity zone – C

Description of Fig 14 and Fig 15

As the clutch is now disengaged, the resistance on the clutch worm wheel (5) is greatly reduced and permits the control worm screw (13.5) to rotate with the pinion & ratchet (13.1) as a whole unit retaining the relative positions. Thereby the lever movement during this period (expansion / deflection zone) is ignored. During this operation if there is any partial engagement between the pawl and ratchet, the Pawl Housing (13.2) will slightly slip back with the control worm screw (13.5) due to Pawl spring (13.4) load to engage in the previous ratchet.

Fig 16 and 17 is the illustration of rotation back through elasticity zone C

Description of Fig 16 and Fig 17

When the brake is released, the pinion & ratchet (13.1) is rotated in clockwise direction by the control gear wheel (19), opposite to the direction of brake application and the control worm screw (13.5) follows the rotation of pinion & ratchet (13.1) as a whole unit along with clutch worm wheel (5) covering the deflection stroke of the Automatic Slack Adjuster. However the worm shaft (6) remains static as the clutch is disengaged between serrations (6") and (5').

Fig 18 and 19 is the illustration of rotation back into the clearance zone A

Description of Fig 18 and Fig 19

Once the brake lining moves away from the brake drum, the force is reduced and the load of the heavy compression spring (10) moves the worm shaft (6) to engage the clutch preventing the free rotation of clutch worm wheel (5).

Fig 20 and 21 is the illustration of rotation back through the clear zone A

Description of Fig 20 and Fig 21

During the further release movement of brake actuator, the body (8) keeps rotating in clock-wise direction, the control gear wheel (19) continues to rotate the pinion & ratchet (13.1), but due to the friction on the clutch worm wheel (5) which is in clutch

engaged condition, the control worm screw (13.5) is retained in same position and pawl housing (13.2) alone is rotated with the pinion & ratchet (13.1) until the closed gap between control worm screw (13.5) and pawl housing (13.2) is restored against the torsion spring (13.9). This movement covers the clearance stroke of the Automatic Slack Adjuster, which was achieved during the initial period of brake application.

Fig 22 and 23 is the illustration of eliminating the slack with rotation back through the excess clearance zone A

Description of Fig 22 and Fig 23

During the final releasing rotation of Automatic Slack Adjuster, the pinion & ratchet (13.1) rotated by the control gear wheel (19) in turn rotates the control worm screw (13.5) [by the one-way lock mechanism between ratchet (13.1') and pawl pin (13.3)] and the clutch worm wheel (5). The worm shaft (6) that is now engaged with clutch worm wheel (5) is rotated and in turn rotates the worm wheel (14) and 'S' camshaft to effect the adjustment of lining clearance. This is in proportion to the new engagement taken place during the brake application stroke explained earlier.

In one aspect the invention discloses an automatic slack adjuster for an automobile with a housing having an aperture for receiving a brake cam shaft comprising of a worm gear coaxially mounted within the said housing aperture and configured to coaxially engage the brake cam shaft, such that the said worm gear and said cam shaft rotating together about a first axis. The arrangement has a bore with a single open end for receiving a worm clutch shaft. The said worm clutch shaft is mounted in the said housing to rotate about a second axis, which is perpendicular to the first axis. The said worm shaft has a first and second sides terminating at first and second ends, and defining a clutch worm gear intermediate wheel engaged with said worm gear. The first end is remote from the housing terminating with a bearing retainer and the first side having a worm shaft ring sandwiched between the clutch worm gear and the bearing retainer. The second end is terminating with a spring and the second side having a spring seat for the said spring and a thrust bush sandwiched between the spring and the worm clutch shaft.

In another aspect the invention discloses a method of assembling an automatic slack adjuster having a housing, the said housing having an aperture for receiving a cam shaft comprising providing a worm gear coaxially mounted within the aperture and configured to coaxially engage the brake cam shaft, such that the worm gear and said cam shaft rotate together about a first axis. The above slack adjuster as described is unknown in prior art. The method also includes providing a bore in the housing with a single open end. The method involves mounting a worm clutch shaft in the said housing and adapting it to rotate about a second axis, which is perpendicular to the first axis. The method involves defining a clutch worm gear intermediate wheel on the worm clutch shaft and arranging a bearing retainer on a first end of the clutch shaft sandwiching a worm shaft ring between the said clutch worm gear and the bearing retainer, arranging a spring with a seat on the second end of the worm clutch shaft, and sandwiching a thrust bush between the said clutch worm gear and the spring. The method of arranging as disclosed above is novel and unknown in prior art.

As described above and with reference to the annexed figures the invention discloses in one aspect an automatic slack adjuster for an automobile. This slack adjuster has a housing with a single aperture for receiving a brake cam shaft. The arrangement includes a worm gear (3) coaxially mounted within the said housing aperture and configured to coaxially engage the brake cam shaft, such that the said worm gear (3) and said cam shaft rotating together about a first axis. The bore has a single open end for receiving a worm shaft (5). The said worm shaft (5) is mounted in the said housing so as to rotate about a second axis, which second axis shall be perpendicular to the first axis. The said worm shaft (5) shall have a first and a second sides terminating at first and second ends. It defines a clutch worm gear intermediate wheel (6) engaged with said worm gear (3). The first end remote from the housing, terminates with a bearing retainer (8). The first side has a worm shaft ring (7) sandwiched between the clutch worm gear (3) and the bearing retainer (8). The second end terminating with a spring (11). The second side having a spring seat (10) for the said spring. A thrust bush (9) is sandwiched between the spring (11) and the worm shaft (5).

In another aspect the invention discloses a method of arranging the components and assembling an automatic slack adjuster. Which automatic slack adjuster having a housing with the said housing having an aperture for receiving a cam shaft. This method involves providing a worm gear (3) coaxially mounted within the aperture and configured to coaxially engage the brake cam shaft, such that the worm gear (3) and said cam shaft rotate together about a first axis. It also comprises of providing a bore in the housing with a single open end, which is the most distinctive arrangement unknown in the prior art. The method comprises of mounting a worm shaft (5) in the said housing and adapting it to rotate about a second axis, which is perpendicular to the first axis. The arrangement also includes defining a clutch worm gear intermediate wheel (6) on the worm shaft (5) and arranging a bearing retainer (8) on a first end of the worm shaft (5). It also includes placing a sealing ring on the groove of the worm shaft (5) and providing sealing between worm shaft (5) and the bearing retainer (8). It further includes arranging a spring (11) with a seat (10) on the second end of the worm clutch shaft (5). The method involves further sandwiching a thrust bush (9) between the said worm shaft (5) and the spring (11).

The description embodiments and illustration are given and used only for easy understanding. All variations and modifications as obvious and known to skilled persons are well within the scope of the invention

CLAIMS:

1. An automatic slack adjuster for an automobile with a housing having an aperture for receiving a brake cam shaft comprising :-
 - a. a worm gear (3) coaxially mounted within the said housing aperture and configured to coaxially engage the brake cam shaft, such that the said worm gear (3) and said cam shaft rotating together about a first axis,
 - b. a bore with a single open end for receiving a worm shaft (5), and
 - c. the said worm shaft (5) mounted in the said housing to rotate about a second axis, which is perpendicular to the first axis, the said worm shaft (5) having a first and second sides terminating at first and second ends, and defining a clutch worm gear intermediate wheel (6) engaged with said worm gear (3), the first end remote from the housing, terminating with a bearing retainer (8), the first side having a worm shaft ring (7) sandwiched between the clutch worm gear (3) and the bearing retainer (8), the second end terminating with a spring (11), the second side having a spring seat (10) for the said spring and a thrust bush (9) sandwiched between the spring (11) and the worm shaft (5).

2. A method of assembling an automatic slack adjuster having a housing, the said housing having an aperture for receiving a cam shaft comprising :-
 - a. providing a worm gear (3) coaxially mounted within the aperture and configured to coaxially engage the brake cam shaft, such that the worm gear (3) and said cam shaft rotate together about a first axis,
 - b. providing a bore in the housing with a single open end,
 - c. mounting a worm shaft (5) in the said housing and adapting it to rotate about a second axis, which is perpendicular to the first axis,
 - d. defining a clutch worm gear intermediate wheel (6) on the worm shaft (5),
 - e. arranging a bearing retainer (8) on a first end of the worm shaft (5),
 - f. placing a sealing ring on the groove of the worm shaft (5) and providing sealing between worm shaft (5) and the bearing retainer (8),
 - g. arranging a spring (11) with a seat (10) on the second end of the worm clutch shaft (5), and
 - h. sandwiching a thrust bush (9) between the said worm shaft (5) and the spring (11).

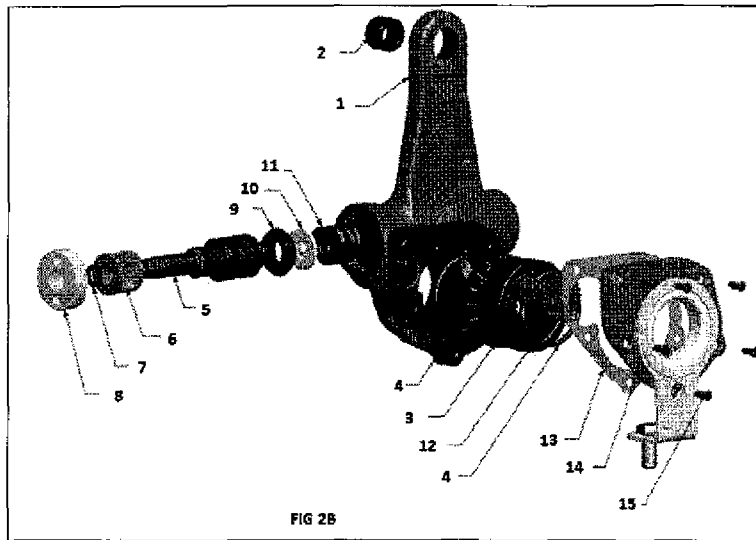
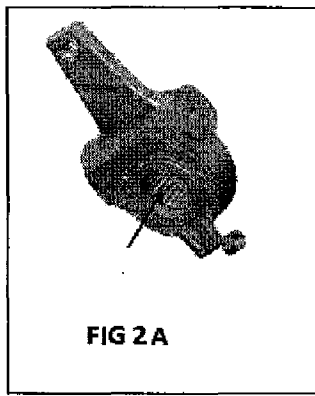
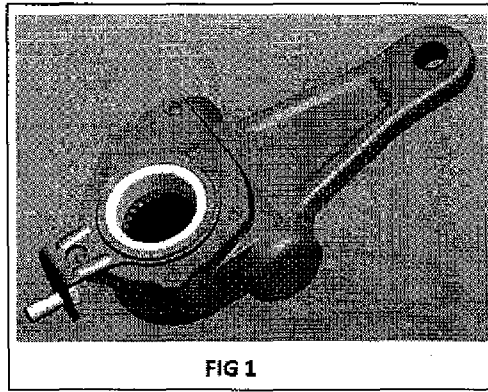

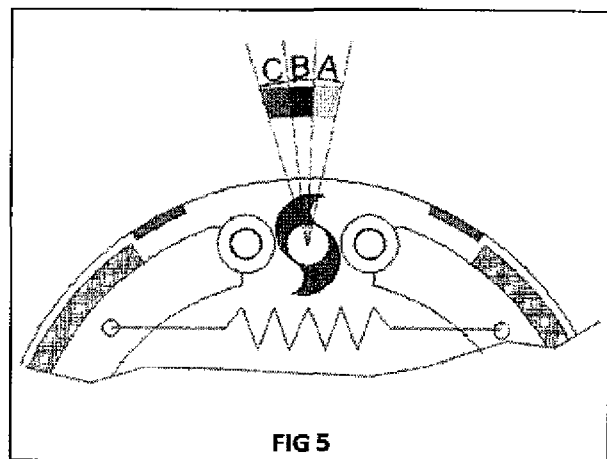
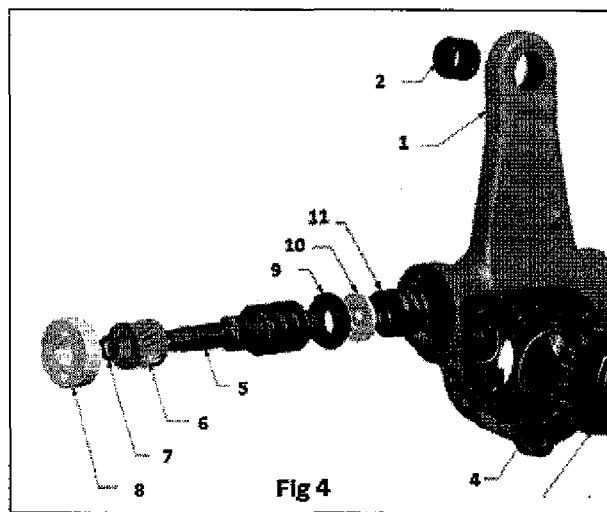
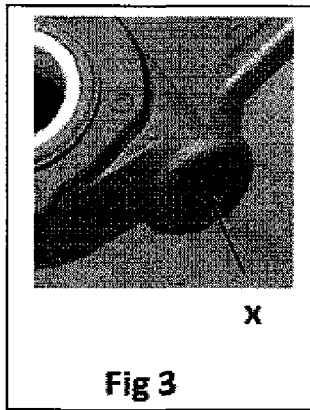

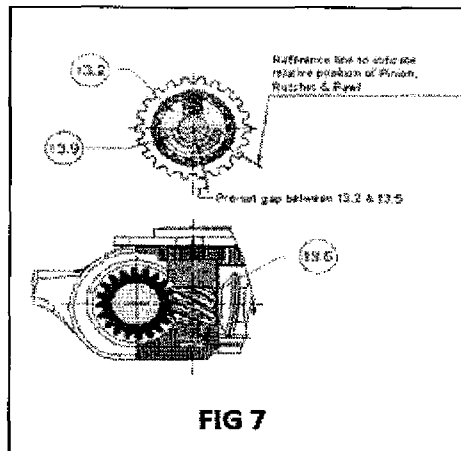
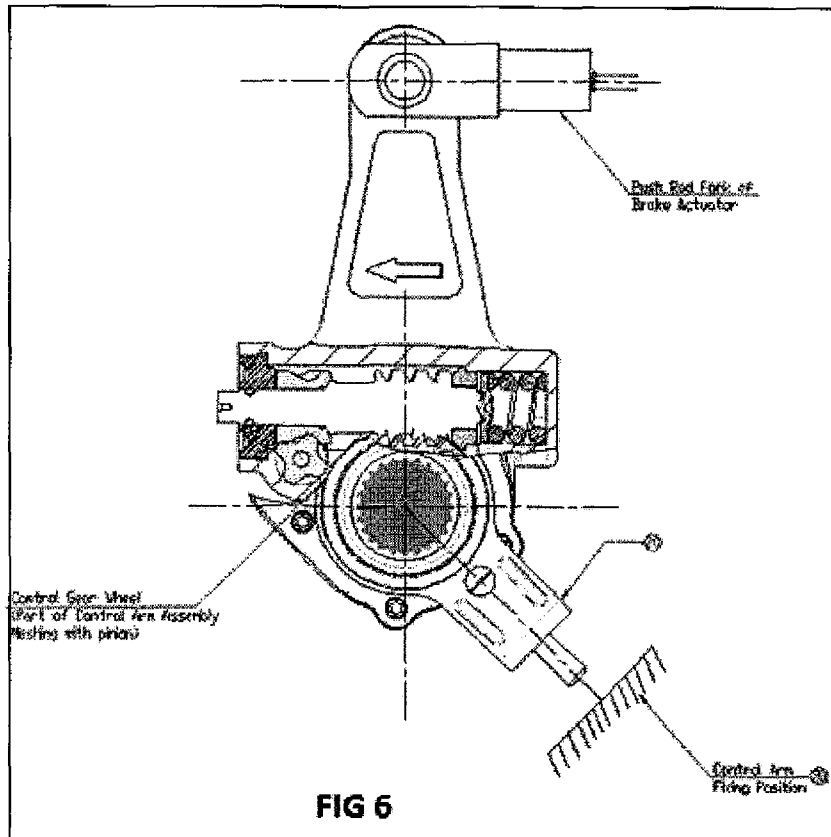

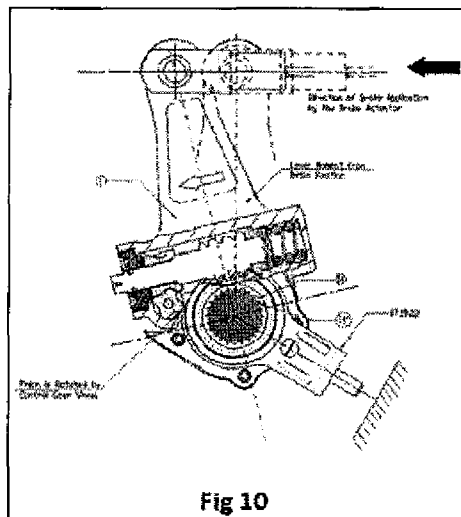
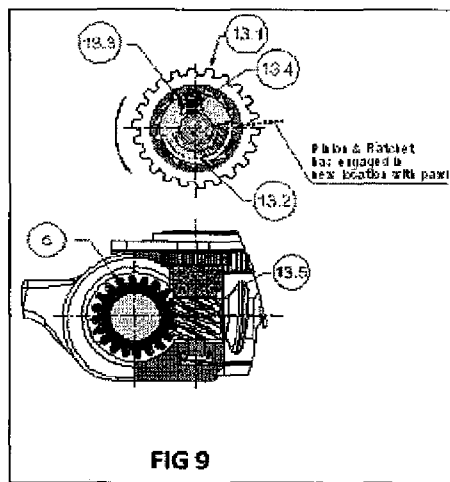
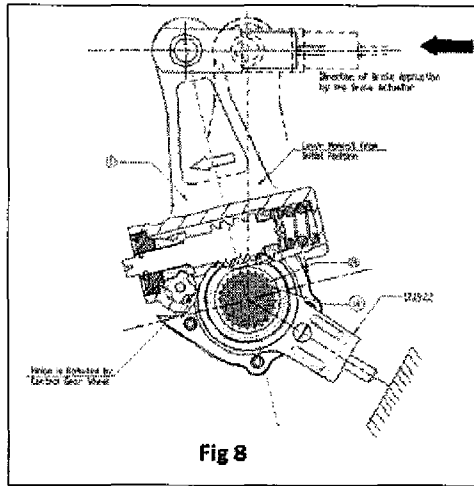

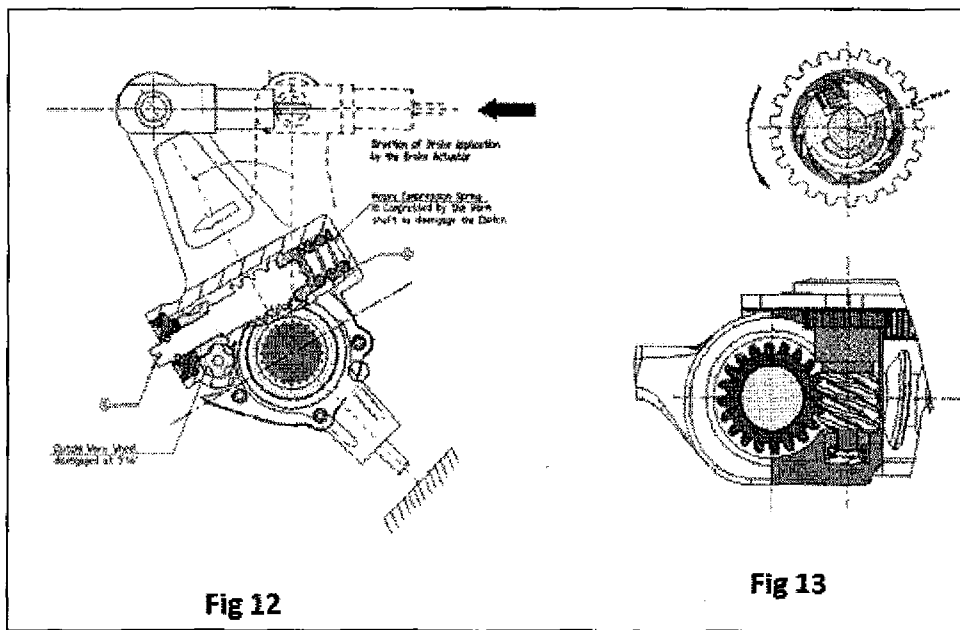
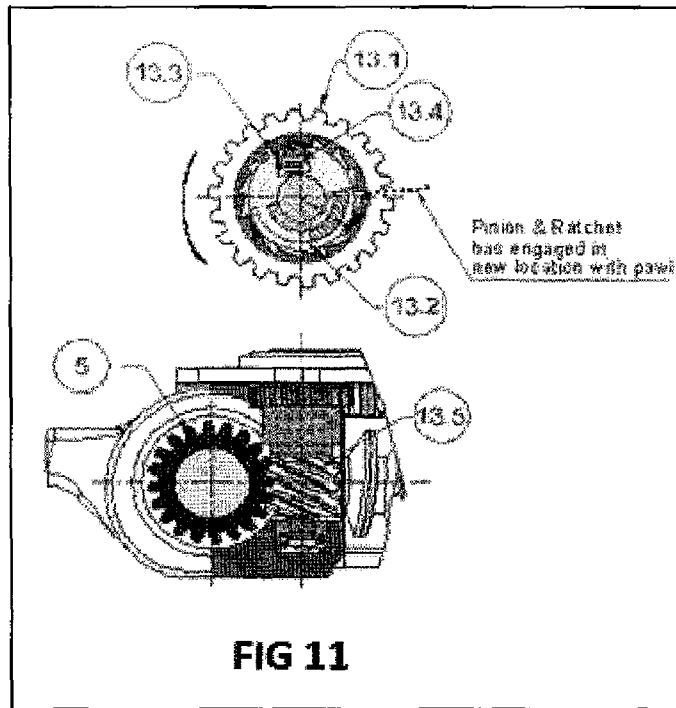

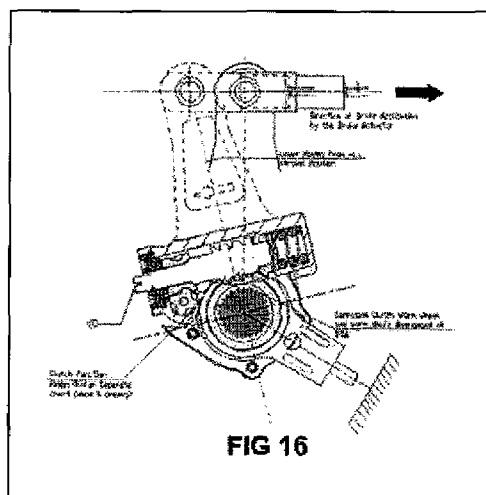
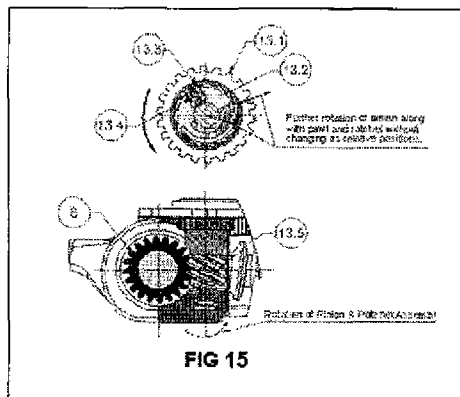
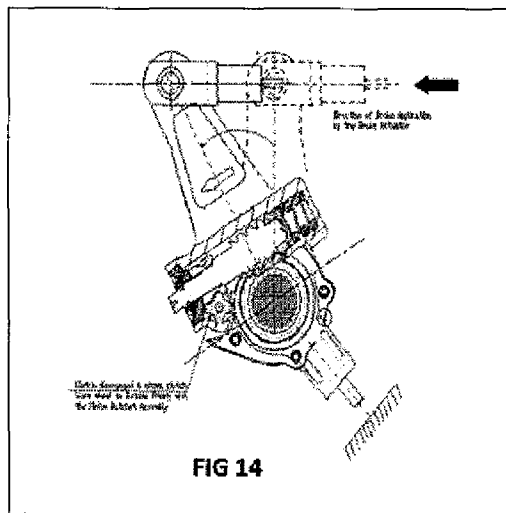

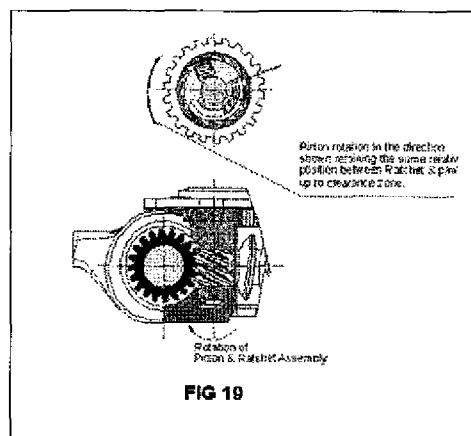
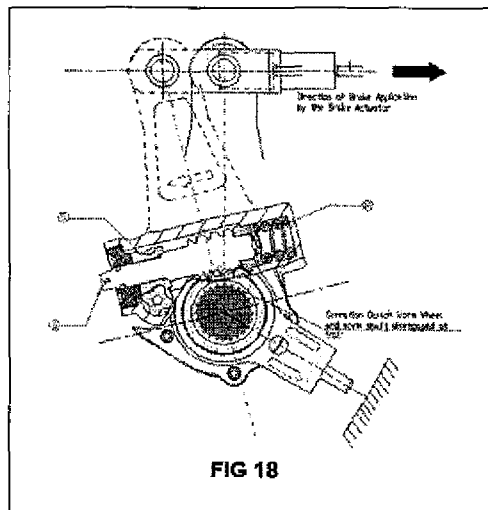
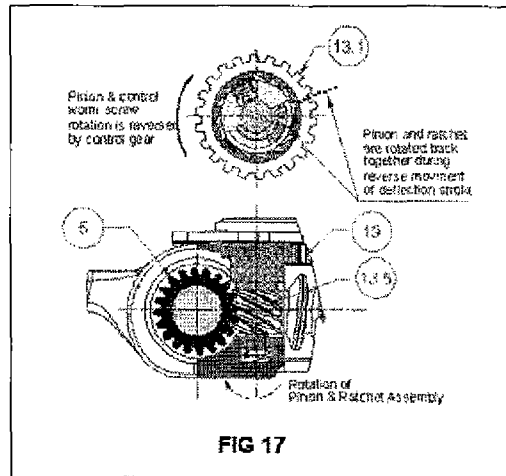

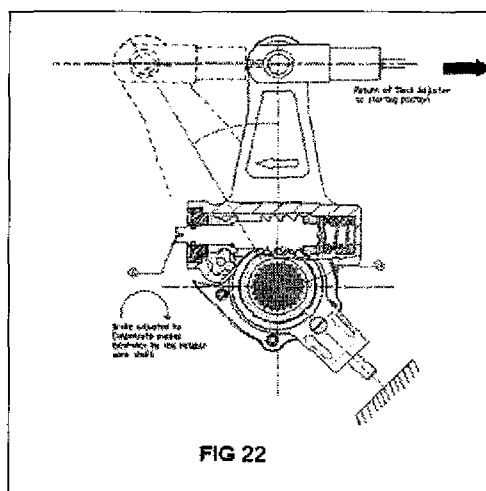
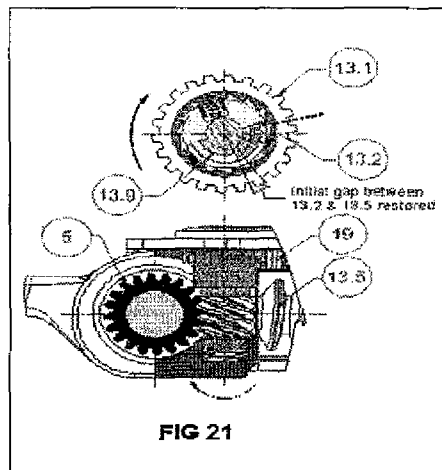
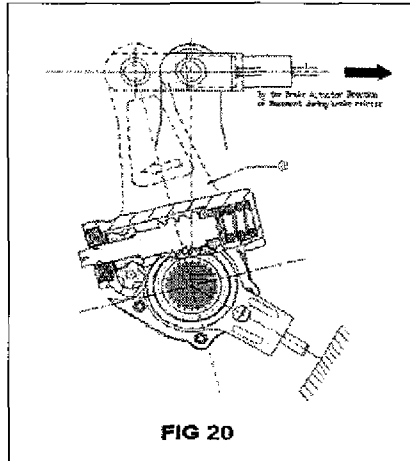

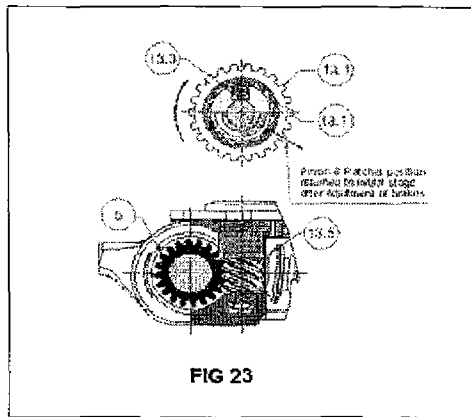

INTERNATIONAL SEARCH REPORT

International application No.
PCT/IN2018/050232

A. CLASSIFICATION OF SUBJECT MATTER
F16D65/38, F16D65/60 Version=2018.01

According to International Patent Classification (IPC) or to both national classification and IPC

B. FIELDS SEARCHED

Minimum documentation searched (classification system followed by classification symbols)

F16D

Documentation searched other than minimum documentation to the extent that such documents are included in the fields searched

Electronic data base consulted during the international search (name of data base and, where practicable, search terms used)

Google Patents

C. DOCUMENTS CONSIDERED TO BE RELEVANT

Category*	Citation of document, with indication, where appropriate, of the relevant passages	Relevant to claim No.
Y	US2013/0240308 A1 (JOSEPH A. KAY et al.; 19 Sep 2013) Abstract; Para. [0004], [0007], [0026]-[0028], [0031], [0033]; Claim 11-16; Fig. 4.	1-2
Y	US 2011/0073422 A1 (HOU QING LI; 31 Mar 2011) Para. [0025], [0028]; Fig. 1.	1-2

Further documents are listed in the continuation of Box C. See patent family annex.

* Special categories of cited documents:	"I" later document published after the international filing date or priority date and not in conflict with the application but cited to understand the principle or theory underlying the invention
"A" document defining the general state of the art which is not considered to be of particular relevance	"X" document of particular relevance; the claimed invention cannot be considered novel or cannot be considered to involve an inventive step when the document is taken alone
"E" earlier application or patent but published on or after the international filing date	"Y" document of particular relevance; the claimed invention cannot be considered to involve an inventive step when the document is combined with one or more other such documents, such combination being obvious to a person skilled in the art
"L" document which may throw doubts on priority claim(s) or which is cited to establish the publication date of another citation or other special reason (as specified)	"&" document member of the same patent family
"O" document referring to an oral disclosure, use, exhibition or other means	
"P" document published prior to the international filing date but later than the priority date claimed	

Date of the actual completion of the international search 02-07-2018	Date of mailing of the international search report 02-07-2018
---	--

Name and mailing address of the ISA/ Indian Patent Office Plot No.32, Sector 14, Dwarka, New Delhi-110075 Facsimile No.	Authorized officer Divyanshu Mishra Telephone No. +91-1125300200
--	--

INTERNATIONAL SEARCH REPORT
Information on patent family members

International application No.
PCT/IN2018/050232

Citation	Pub.Date	Family	Pub.Date
US 2013/0240308 A1	19-09-2013	BR 102013006409 A2	09-06-2015
		CN 103307153 A	18-09-2013
		EP 2639474 A2	18-09-2013
US 2011073422 A1	31-03-2011	CN 101526116 A	09-09-2009
		KR 20100124249 A	26-11-2010
		WO 2010108302 A1	30-09-2010