

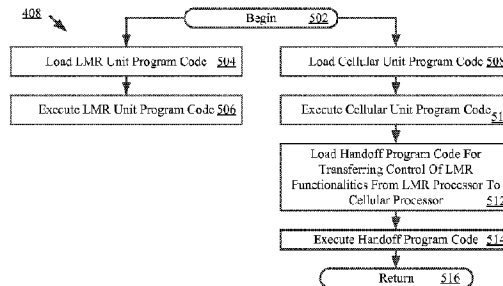

(86) Date de dépôt PCT/PCT Filing Date: 2014/07/01  
 (87) Date publication PCT/PCT Publication Date: 2015/01/15  
 (45) Date de délivrance/Issue Date: 2020/06/30  
 (85) Entrée phase nationale/National Entry: 2016/01/05  
 (86) N° demande PCT/PCT Application No.: US 2014/045044  
 (87) N° publication PCT/PCT Publication No.: 2015/006098  
 (30) Priorité/Priority: 2013/07/10 (US13/938,605)

(51) Cl.Int./Int.Cl. *H04W 88/06* (2009.01),  
*G06F 9/4401* (2018.01), *H04W 4/90* (2018.01)  
 (72) Inventeurs/Inventors:  
WARSAW, THOMAS, US;  
TENNANT, BRYCE, US  
 (73) Propriétaire/Owner:  
HARRIS CORPORATION, US  
 (74) Agent: LAVERY, DE BILLY, LLP

(54) Titre : SYSTEMES ET PROCEDES POUR UNE DISPONIBILITE RAPIDE DE FONCTIONNALITES ESSENTIELLES SUR DES DISPOSITIFS AU MOYEN DE SYSTEMES D'EXPLOITATION CELLULAIRES  
 (54) Title: SYSTEMS AND METHODS FOR RAPID AVAILABILITY OF CRITICAL FUNCTIONALITIES ON DEVICES USING CELLULAR OPERATING SYSTEMS

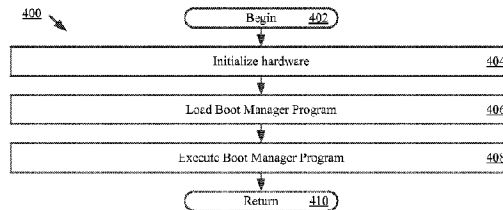

(57) **Abrégé/Abstract:**

Systems (100) and methods (400) for operating a hybrid communication device (106). The methods involve executing at least one boot program. Responsive to the boot program, a first and second code are concurrently executed. The first code is operative for booting at least a real-time operating system on which a radio processor of the hybrid communication device is built. The second code is operative for booting at least a mobile operating system on which a cellular processor of the hybrid communication device is built. The radio processor provides support for wireless radio communication while the mobile operating system is booting.

(12) INTERNATIONAL APPLICATION PUBLISHED UNDER THE PATENT COOPERATION TREATY (PCT)

(19) World Intellectual Property Organization  
International Bureau



(10) International Publication Number  
**WO 2015/006098 A1**

(43) International Publication Date  
15 January 2015 (15.01.2015)

- (51) International Patent Classification:  
H04W 88/06 (2009.01) G06F 9/44 (2006.01)  
H04W 4/22 (2009.01) H04W 76/00 (2009.01)
- (21) International Application Number: PCT/US2014/045044
- (22) International Filing Date: 1 July 2014 (01.07.2014)
- (25) Filing Language: English
- (26) Publication Language: English
- (30) Priority Data: 13/938,605 10 July 2013 (10.07.2013) US
- (71) Applicant: HARRIS CORPORATION [US/US]; 1025 W. Nasa Blvd., M/S A-11I, Melbourne, Florida 32901 (US).
- (72) Inventors: WARSAW, Thomas; 40 Alverstone Way, West Henrietta, New York 14586-9676 (US). TENNANT, Bryce; 144 Collingsworth Drive, Rochester, New York 14625 (US).
- (74) Agents: BLUM, Ronald, S., III et al.; Harris Corporation, 1025 W. Nasa Blvd., M/S A-11I, Melbourne, Florida 32919 (US).
- (81) Designated States (unless otherwise indicated, for every kind of national protection available): AE, AG, AL, AM, AO, AT, AU, AZ, BA, BB, BG, BH, BN, BR, BW, BY, BZ, CA, CH, CL, CN, CO, CR, CU, CZ, DE, DK, DM, DO, DZ, EC, EE, EG, ES, FI, GB, GD, GE, GH, GM, GT, HN, HR, HU, ID, IL, IN, IR, IS, JP, KE, KG, KN, KP, KR, KZ, LA, LC, LK, LR, LS, LT, LU, LY, MA, MD, ME, MG, MK, MN, MW, MX, MY, MZ, NA, NG, NI, NO, NZ, OM, PA, PE, PG, PH, PL, PT, QA, RO, RS, RU, RW, SA, SC, SD, SE, SG, SK, SL, SM, ST, SV, SY, TH, TJ, TM, TN, TR, TT, TZ, UA, UG, US, UZ, VC, VN, ZA, ZM, ZW.

[Continued on next page]

(54) Title: SYSTEMS AND METHODS FOR RAPID AVAILABILITY OF CRITICAL FUNCTIONALITIES ON DEVICES USING CELLULAR OPERATING SYSTEMS

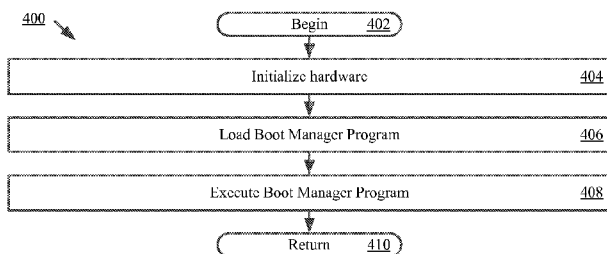

FIG. 4

(57) Abstract: Systems (100) and methods (400) for operating a hybrid communication device (106). The methods involve executing at least one boot program. Responsive to the boot program, a first and second code are concurrently executed. The first code is operative for booting at least a real-time operating system on which a radio processor of the hybrid communication device is built. The second code is operative for booting at least a mobile operating system on which a cellular processor of the hybrid communication device is built. The radio processor provides support for wireless radio communication while the mobile operating system is booting.

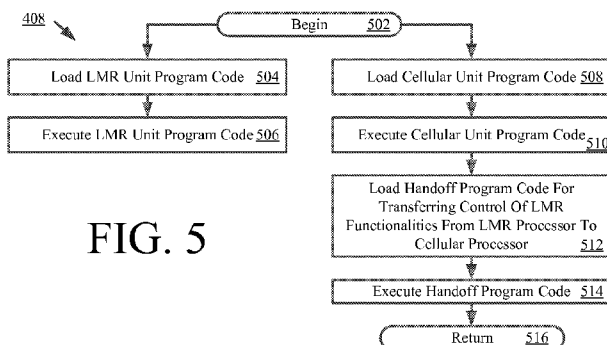

FIG. 5

WO 2015/006098 A1

**WO 2015/006098 A1** 

- (84) Designated States** (*unless otherwise indicated, for every kind of regional protection available*): ARIPO (BW, GH, GM, KE, LR, LS, MW, MZ, NA, RW, SD, SL, SZ, TZ, UG, ZM, ZW), Eurasian (AM, AZ, BY, KG, KZ, RU, TJ, TM), European (AL, AT, BE, BG, CH, CY, CZ, DE, DK, EE, ES, FI, FR, GB, GR, HR, HU, IE, IS, IT, LT, LU, LV, MC, MK, MT, NL, NO, PL, PT, RO, RS, SE, SI, SK, SM, TR), OAPI (BF, BJ, CF, CG, CI, CM, GA, GN, GQ, GW, KM, ML, MR, NE, SN, TD, TG).
- Published:**
- *with international search report (Art. 21(3))*
  - *before the expiration of the time limit for amending the claims and to be republished in the event of receipt of amendments (Rule 48.2(h))*

## SYSTEMS AND METHODS FOR RAPID AVAILABILITY OF CRITICAL FUNCTIONALITIES ON DEVICES USING CELLULAR OPERATING SYSTEMS

### Statement of the Technical Field

The inventive arrangements relate to systems and methods for rapid availability of  
5 certain functionalities on devices using cellular operating systems. More particularly, the  
inventive arrangements concern hybrid communications equipment in which certain  
functionalities (e.g., Land Mobile Radio (“LMR”) functionalities) are made available while a  
mobile operating system boots, and in which a subsequent hand over of control of these  
functionalities is made to the mobile operating system.

### 10 Description of the Related Art

LMR devices may be used to provide communication between different mobile units.  
LMR communication, for example, public safety radio communication (e.g., police, fire  
department, etc.) is generally available within the VHF, UHF, 700 MHz and 800 MHz frequency  
bands. Part of each of these frequency bands is allocated by the Federal Communications  
15 Commission (“FCC”) for public safety communication services and are also referred to as Public  
Safety Frequency Bands (“PSFBs”). These communications also may be provided using private  
LMR Services (“PLMRS”).

When LMRs are used, for example, to provide emergency communications,  
interoperability between different systems (e.g., a fire department LMR system and a police  
20 department LMR system, or different fire department LMR systems) is important. However,  
each of the different systems may have different communication requirements based on, for  
example, the manufacturer of the LMR or LMR system and/or the air interface protocol  
implemented on the system (e.g., trunked or conventional, M/A-COM or Motorola, P25,  
Enhanced Digital Access Communications System (“EDACS”), OPENSKY.RTM. or Terrestrial  
25 Trunked Mobile Radio (“TETRA”)). Each of these different systems typically include a specific  
voice encoder (“vocoder”) and have different encryption schemes. For example, a P25 system  
typically uses an Improved Multi-Band Excitation (“IMBE”) vocoder with Data Encryption  
Standard (“DES”) or Advanced Encryption Standard (“AES”) encryption while an

OPENSKY.RTM. system typically uses an Advanced Multi-Band Excitation (“AMBE.RTM.”) vocoder with AES encryption. Various techniques have been implemented for allowing these different systems to inter-operate.

5 Public safety customers expect LMR devices to have a high availability, which they equate with: providing full on-air radio functionality within three seconds of booting or re-booting; and providing reliable operations (i.e., never experiencing a system crash). However, LMR devices do not provide the same functionalities as that of a Smartphone.

10 A Smartphone typically employs a mobile operating system, such as Google’s Android. The mobile operating system provides rich functionalities that are desirable in a broadband device. For example, the mobile operating system provides a map functionality, a calendar functionality, an electronic mail functionality, and a web browser functionality. But, the mobile operating system lacks some characteristics needed to match the high availability performance existing in LMR devices. This drawback of mobile operating system results from: the relatively long time required to boot (e.g., greater than or equal to 15 seconds); and the  
15 relatively high risk of a system crash.

Notably, there is no push-to-talk device using a cell phone operating system that is currently being sold as a mission critical solution for public safety users. Therefore, there is a need for such a communication device. This communication device should have the high availability performance of existing LMR devices and the rich functionalities of existing cellular  
20 devices.

### **SUMMARY OF THE INVENTION**

The present invention concerns systems and methods for operating a hybrid communication device. The methods involve executing at least one boot program. In response to the boot program, a first code and a second code are concurrently executed. The first code is  
25 configured for booting at least a real-time operating system on which a radio processor of the hybrid communication device is built. The second code is configured for booting at least a mobile operating system on which a cellular processor of the hybrid communication device is built. The radio processor provides support for wireless radio communication functionalities

while the mobile operating system is booting. In this regard, the radio processor controls a first portion of a plurality of input and output devices of the hybrid communication device that are necessary for providing the wireless radio communication functionalities, while the mobile operating system is booting.

5           The methods also involve executing a third code after the mobile operating system has fully booted. The third code is configured for: (a) transferring control of the first portion of the input and output devices from the radio processor to the cellular processor; and/or (b) transferring control of the wireless radio communication functionalities from the radio processor to the cellular processor. In some scenarios, the process for transferring such control involves:  
10 performing operations by the cellular processor to notify the radio processor that it is ready to accept control of the wireless radio communication functionalities; and performing operations by the radio processor to determine when to transfer control of the wireless radio communication functionalities to the cellular processor based on a pre-defined criteria. The pre-defined criteria can include, but is not limited to, an operating state of the radio processor and a current activity  
15 of the radio processor.

After such control has been transferred, the cellular processor acts as a master processor, while the radio processor acts as a slave processor. As the slave processor, the radio processor monitors activities of the cellular processor to detect a system crash. If a system crash is detected, then the radio processor performs operations to: (a) re-take control of the wireless  
20 radio communication functionalities; and/or re-set the cellular processor so as to bring it to an initial state.

### **BRIEF DESCRIPTION OF THE DRAWINGS**

Embodiments will be described with reference to the following drawing figures, in which like numerals represent like items throughout the figures, and in which:

25           FIG. 1 is a schematic illustration of an exemplary communication system that is useful for understanding the present invention.

FIG. 2 is a schematic illustration of an exemplary architecture for a hybrid unit shown in FIG. 1.

FIG. 3 is a schematic illustration of an exemplary software architecture for a communication device that is useful for understanding the present invention.

FIG. 4 is a flowchart of a software routine for booting the hybrid unit showing FIGS. 1-2.

5 FIG. 5 is a flowchart of a software routine for the execute boot manager program step of FIG. 4.

FIG. 6 is a flowchart of a software routine for the execute LMR unit program code step of FIG. 5.

10 FIG. 7 is a schematic illustration showing the hardware that is available after the software routine of FIG. 6 has been performed.

FIG. 8 is a flowchart of a software routine for the execute cellular unit program code step of FIG. 5.

FIG. 9 is a schematic illustration showing the additional hardware that is available after the software routine of FIG. 8 has been performed.

15 FIG. 10 is a flowchart of a software routine for the execute handoff program code step of FIG. 5.

### **DETAILED DESCRIPTION**

It will be readily understood that the components of the embodiments as generally described herein and illustrated in the appended figures could be arranged and designed in a wide  
20 variety of different configurations. Thus, the following more detailed description of various embodiments, as represented in the figures, is not intended to limit the scope of the present disclosure, but is merely representative of various embodiments. While the various aspects of the embodiments are presented in drawings, the drawings are not necessarily drawn to scale unless specifically indicated.

The present invention may be embodied in other specific forms without departing from its spirit or essential characteristics. The described embodiments are to be considered in all respects as illustrative. The scope of the invention is, therefore, indicated by the appended claims. All changes which come within the meaning and range of equivalency of the claims are to be embraced within their scope.

Reference throughout this specification to features, advantages, or similar language does not imply that all of the features and advantages that may be realized with the present invention should be or are in any single embodiment of the invention. Rather, language referring to the features and advantages is understood to mean that a specific feature, advantage, or characteristic described in connection with an embodiment is included in at least one embodiment of the present invention. Thus, discussions of the features and advantages, and similar language, throughout the specification may, but do not necessarily, refer to the same embodiment.

Furthermore, the described features, advantages and characteristics of the invention may be combined in any suitable manner in one or more embodiments. One skilled in the relevant art will recognize, in light of the description herein, that the invention can be practiced without one or more of the specific features or advantages of a particular embodiment. In other instances, additional features and advantages may be recognized in certain embodiments that may not be present in all embodiments of the invention.

Reference throughout this specification to “one embodiment”, “an embodiment”, or similar language means that a particular feature, structure, or characteristic described in connection with the indicated embodiment is included in at least one embodiment of the present invention. Thus, the phrases “in one embodiment”, “in an embodiment”, and similar language throughout this specification may, but do not necessarily, all refer to the same embodiment.

As used in this document, the singular form “a”, “an”, and “the” include plural references unless the context clearly dictates otherwise. Unless defined otherwise, all technical and scientific terms used herein have the same meanings as commonly understood by one of ordinary skill in the art. As used in this document, the term “comprising” means “including, but not limited to”.



Embodiments will now be described with respect to FIGS. 1-13C. Embodiments generally relate to communication devices employing real-time operating systems and cellular operating systems. A person can appreciate the need in a public safety and/or military context of being able to use a communication device almost instantaneously in emergency situations. For example, in a time-critical situation, such as when a group of public safety personnel (e.g., police officers) and/or armed forces comes under attack, the need to be able to relay information between other members of the public safety personnel and/or armed forces as quickly as possible is absolutely necessary. Accordingly, the systems of the present invention implement a boot process which takes a relatively short amount of time to power up at least a portion thereof where it is able to perform critical or emergency communications. The systems also implement a software routine which ensures that critical or emergency communications can be performed even when the communication device experiences a system crash.

Referring now to FIG. 1, there is provided a schematic illustration of an exemplary communication system **100** that is useful for understanding the present invention. The system **100** comprises a plurality of LMR units **102**, **104**, hybrid units **106**, **108**, and cellular units **110**, **112**. LMR units and cellular units are well known in the art, and therefore will not be described herein. Still, it should be understood that communications between the LMR units **102**, **104** are provided via an LMR network **114**. The LMR network **114** can include, but is not limited to, a P25 network, a TETRA network, an OPENSky network, an EDACS network, and a Long Term Evolution (“LTE”) network. Communications between the cellular units **110**, **112** are via a cellular network **116**.

The hybrid units **106**, **108** are generally configured to communicate with LMR units via the LMR network **114** and cellular units **110**, **112** via the cellular network **116**. The hybrid units **106**, **108** can also communicate with each other via the LMR network **114** and/or the cellular network **116**. In this regard, the hybrid units **106**, **108** have functionalities supported by a real-time operating system and a mobile operating system, as will be described in more detail below. The mobile operating system can include, but is not limited to, Google’s Android, Apple’s iOS, Nokia’s Symbian, RIM’s BlackBerry OS, Samsung’s Bada, Microsoft’s Windows Phone, Hewlett-Packard’s webOS, and embedded Linux distributions such as Maemo and MeeGo. A more detailed schematic illustration of a hybrid unit is provided in FIG. 2.

Referring now to FIG. 2, a schematic illustration of an exemplary architecture for the hybrid unit **106** of FIG. 1 is provided. Hybrid unit **108** of FIG. 1 is the same as or similar to hybrid unit **106**. As such, the following discussion of hybrid unit **106** is sufficient for understanding hybrid unit **108** of FIG. 1. Hybrid unit **106** may include more or less components than those shown in FIG. 2. However, the components shown are sufficient to disclose an illustrative embodiment implementing the present invention. In this regard, hybrid unit **106** implements methods for providing the high availability performance of existing LMR devices and the rich functionalities of existing cellular devices. Exemplary embodiments of such methods will be described below in relation to FIGS. 4-10. Some or all of the components of the hybrid unit **106** can be implemented in hardware, software and/or a combination of hardware and software. The hardware includes, but is not limited to, one or more electronic circuits.

As shown in FIG. 2, hybrid unit **106** comprises an LMR processor **250** and a cellular processor **252**. Embodiments of the present invention are not limited in this regard. For example, hybrid unit **106** can alternatively include a single processor with multiple cores running two different operating systems, such as a real-time operating system and a cellular operating system side by side.

The LMR processor **250** is built on a real-time operating system, and is generally configured to provide LMR communication functionalities. The LMR communication functionalities can include, but are not limited to, a Push-To-Talk (“PTT”) functionality, a radio communication functionality, a radio channel control functionality, a waveform control functionality, a volume control functionality, a top display control functionality, an auditory output functionality, a visual output functionality, a talkgroup selection functionality, a destination device selection functionality, location tracking and reporting functionalities, and map or navigation functionalities. The listed LMR processor functionalities are well known in the art, and therefore will not be described in detail herein.

The cellular processor **252** is built on a mobile operating system. The mobile operating system includes, but is not limited to, Google’s Android, Apple’s iOS, Nokia’s Symbian, RIM’s BlackBerry OS, Samsung’s Bada, Microsoft’s Windows Phone, Hewlett-Packard’s webOS, and embedded Linux distributions such as Maemo and MeeGo. The cellular processor **252** is also generally configured to provide cellular communication functionalities,

personal digital assistant functionalities, portable media player functionalities, digital camera functionalities, video camera functionalities, location tracking functionalities, web browser functionalities, and touch screen functionalities. The cellular communication functionalities include, but are not limited to, a signal transmit/receive functionality, a volume control  
5 functionality, a front display control functionality, a button control functionality, and a speaker/microphone control functionality. The personal digital assistant functionalities include, but are not limited to, a map functionality, a calendar functionality, and an electronic mail functionality. The listed cellular processor functionalities are well known in the art, and therefore will not be described in detail herein.

10 Accordingly, each processor **250, 252** includes hardware and/or software components for facilitating the LMR or cellular communications. As shown in FIG. 2, this hardware includes an antenna **202, 204**, a transceiver **206, 208**, a controller **210, 212**, and memory **214, 216**. The antenna **202, 204** is provided for receiving and transmitting signals communicated via a  
15 respective one of an LMR network (e.g., LMR network **114** of FIG. 1) and a cellular network (e.g., cellular network **116** of FIG. 1). The transceiver **206, 208** may include a receive/transmit (“Rx/Tx”) switch (not shown). In such scenarios, the Rx/Tx switch selectively couples the respective antenna **202, 204** to transmitter circuitry (not shown) and receiver circuitry (not shown) of the transceiver **206, 208** in a manner familiar to those skilled in the art.

20 During operation, the receiver circuitry (not shown) demodulates and decodes the signals received from a network (e.g., the network **114** or **116** of FIG. 1) to derive information therefrom. The receiver circuitry (not shown) is coupled to a controller **210, 212** via an electrical connection **280**. The receiver circuitry (not shown) provides the decoded signal information to the controller **210, 212**. The controller **210, 212** uses the decoded signal information in  
25 accordance with the function(s) of the hybrid unit **106**. For example, if the signals include identifier information and/or location information for other communication devices (e.g., devices **102, 104, 108, 110, 112** of FIG. 1), then the identifier and/or location information can be used by the controller **210, 212** to identify other devices that are pre-defined distances from or within  
range of the hybrid unit **106**. The controller **210, 212** also provides information to the transmitter circuitry (not shown) of the transceiver **206, 208** for encoding and modulating information into  
30 transmit signals. Accordingly, the controller **210, 212** is coupled to the respective transmitter

circuitry (not shown) via electrical connection **282, 284**. The transmitter circuitry (not shown) communicates the transmit signals to the antenna **202, 204** for transmission to an external device (e.g., network equipment of network **114, 116** of FIG. 1).

An antenna **218** is coupled to GPS receiver circuitry **220** for receiving GPS signals.

5 The GPS receiver circuitry **220** demodulates and decodes the GPS signals to extract GPS location information therefrom. The GPS location information indicates the location of the hybrid unit **106**. The GPS receiver circuitry **220** provides the decoded GPS location information to one or both controllers **210, 212**. As such, the GPS receiver circuitry **220** is coupled to the controller **210** via electrical connection **286** and controller **212** via electrical connection **288**.  
10 Notably, the present invention is not limited to GPS based methods for determining a location of hybrid unit **106**. Other methods for determining a location of a communication device can be used with the present invention without limitation.

The controllers **210, 212** use the decoded GPS location information in accordance with the function(s) of the hybrid unit **106**. For example, the GPS location information and/or  
15 other location information can be used to generate a geographic map showing the location of the hybrid unit **106**. The GPS location information and/or other location information can also be used to determine the actual or approximate distance between the hybrid unit **106** and other communication devices (e.g., devices **102, 104, 108, 110, 112** of FIG. 1).

The controllers **210, 212** store the decoded receive signal information and the  
20 decoded GPS location information in a respective memory **214, 216**. Accordingly, the memory **214, 216** is connected to and accessible by the respective controller **210, 212** through an electrical connection **290, 292**. The memory **214, 216** can be a volatile memory and/or a non-volatile memory. For example, the memory **214, 216** can include, but is not limited to, a  
25 Random Access Memory (“RAM”), a Dynamic Random Access Memory (“DRAM”), a Static Random Access Memory (“SRAM”), a Read-Only Memory (“ROM”), and a flash memory. The memory **214, 216** can also have stored therein software applications **278, 277**.

The software applications **278** include, but are not limited to, applications operative to provide LMR communication services, PTT services, emergency communication services, GPS based services, map or navigation services, location tracking services, position reporting

services, and cryptographic services. The software applications **277** include, but are not limited to, applications operative to provide telephone services, network communication services, GPS based services, map or navigation services, location tracking services, position reporting services, commerce services, email services, web based services, and/or electronic calendar services. The software applications **277**, **278** are also operative to determine the positions of other devices and/or determine the location of the hybrid unit **106** relative to the other devices and/or landmarks (e.g., an intersection or a site of historical significance).

As shown in FIG. 2, one or more sets of instructions **275** are stored in the memory **214** of the LMR processor **250**. Similarly, one or more sets of instructions **276** are stored in the memory **216** of the cellular processor **252**. The instructions **275**, **276** can also reside, completely or at least partially, within the respective controller **210**, **212** during execution thereof by the hybrid unit **106**. In this regard, the memories **214**, **216** and the controllers **210**, **212** can collectively or respectively constitute machine-readable media. The term "machine-readable media", as used here, refers to a single medium or multiple media that store the one or more sets of instructions **275**, **276**. The term "machine-readable media", as used here, also refers to any medium that is capable of storing, encoding or carrying the set of instructions **275**, **276** for execution by the hybrid unit **106** and that cause the hybrid unit **106** to perform one or more of the methodologies of the present disclosure.

Each of the controllers **210**, **212** is also connected to a user interface **222**. The user interface **222** is comprised of input devices **224**, output devices **226**, and software routines (not shown in FIG. 2) configured to allow a user to interact with and control software applications **277**, **278** installed on the hybrid unit **106**. The input devices **224** include first stage input devices **262** and second stage input devices **260**. The first stage input devices include those input devices which are necessary to provide critical or emergency communications as quickly as possible after power up of the hybrid unit **106** or a re-boot of the cellular processor **252** thereof. Such input devices include, but are not limited to, a PTT button **230**, LMR control knobs **232**, an LMR microphone **234**, and a wired microphone accessory **240**. The second stage input devices **260** include, but are not limited to, cellular unit buttons **226**, a cellular unit key pad **227**, and a microphone assembly **228**. The microphone assembly **228** can include, but is not limited to, a Near Field Communication ("NFC") microphone assembly and/or a Bluetooth microphone

assembly. Each of the listed input devices is well known in the art, and therefore will not be described herein. Notably, in some scenarios, the microphone assembly **228** (e.g., the Bluetooth microphone assembly) is a first stage input device **262**, rather than a second stage input device **260**.

5                   Similarly, the output devices **226** include first stage output devices **272** and second stage output devices **270**. The first stage output devices **272** include those output devices which are necessary to provide critical or emergency communications as quickly as possible after power up of the hybrid unit **106** or a re-boot of the cellular processor **252** thereof. Such output devices include, but are not limited to, Light Emitting Diodes (“LEDs”) **236**, a top display **248**, a  
10 hands free loud speaker **251**, and a wired speaker **253**. The second stage output devices **270** include, but are not limited to, a front display **242**, a speaker assembly **244**, and a cellular unit receiver speaker **246**. The speaker assembly **244** can include, but is not limited to, a Near Field Communication (“NFC”) speaker assembly and/or a Bluetooth speaker assembly. Each of the listed output devices is well known in the art, and therefore will not be described herein.  
15 Notably, in some scenarios, the speaker assembly **244** (e.g., the Bluetooth speaker assembly) is a first stage output device **272**, rather than a second stage output device **270**.

Referring now to FIG. 3, there is provided a schematic illustration of an exemplary software architecture **300** employed by the LMR processor **250** and the cellular processor **252** of FIG. 2. The software architecture **300** can include levels of software programs. As shown in  
20 FIG. 3, the software architecture **300** includes device driver software programs **312-1**, **312-2**, . . . , **312-N**, an operating system **310**, platform devices and services software programs **308**, and software applications **302**, **304**, **306**. The software programs of the architecture **300** are well known to persons skilled in the art. Thus, the software programs will only be briefly described herein.

25                   A device driver program **312-1**, **312-2**, . . . , **312-N** is software the hybrid unit **106** uses to facilitate communications between hardware components. A device driver program **312-1**, **312-2**, . . . , **312-N** can include code for managing access to hardware components, taking hardware components in and out of services (i.e., allocation or de-allocate), setting hardware component parameters, and transmitting data between hardware components. For example, a

device driver program **312-1, 312-2, . . . , 312-N** can allocate or de-allocate a transmit device and/or a receive device.

The operating system **310** includes a mobile operating system or a real-time operating system. As noted above, the LMR processor **250** of FIG. 2 is built on a real-time operating system. In contrast, the cellular processor **252** of FIG. 2 is built on the mobile operating system. The operating system **310** is generally configured for the direct control and management of the hybrid unit **106** hardware of FIG. 2. Typically, the operating system **310** manages basic processing operations, such as loading and running software applications. The operating system may also be responsible for: transforming data structures to network defined structures, such as byte sequences, for transmission over a network; enabling system switching between software programs and tracing the location of software programs; and enabling a user to control hardware coupled to the hybrid unit **106**. The operating system can also include instructions to install, launch, and manage applications. The operating system is typically stored in memory **214** and/or **216** of FIG. 2, which may be a ROM, hard drive or other storage device.

The platform devices and services **308** enable software components written in multiple computer languages to work together. The platform devices and services **308** can include a display configuration provider (not shown), a communications provider (not shown), and other providers/services known in the art. The display configuration provider (not shown) is software responsible for the direct control and management of display configurations. Display configurations are well known to those having ordinary skill in the art, and therefore will not be described herein.

The software applications **302, 304, 306** include programs designed for end users, such as communication programs (“waveforms”) and database programs. For example, in the LMR processor scenario, the software application **302** is a radio channel control program, a waveform control program, and/or a communications application. The radio channel control program can include instructions for selecting a radio channel and configuring radio devices for enabling a user to listen to radio broadcasts. The waveform control program can include instructions for enabling a signal transmission by defining a frequency bandwidth, modulation, encryption, and/or decryption. The communication application includes instructions for frequency selection, modulation and/or demodulation. The communication application can be

hardware entity independent. For example, the communication application can include instructions for communicating with a number of hardware entities for performing frequency selection, modulation, and/or demodulation. The software applications **302**, **304**, **306** are installed on the hybrid unit **106**.

5           A person skilled in the art will appreciate that the software architecture **300** illustrates an embodiment of a software architecture in which the methods described below can be implemented. The invention is not limited in this regard and any other software architecture specified by a radio or cellular communication architecture may be used without limitation.

10           FIG. 4 is a flowchart of a boot software routine **400** for a hybrid unit (e.g., hybrid unit **106** or **108** of FIG. 1). Boot software contains a defined routine for getting the hybrid unit fully operational (i.e., up and running). The boot software routine **400** provides certain functionalities (e.g., critical LMR communication capabilities) to a user almost instantaneously by simultaneously booting LMR software programs and cellular software programs. The LMR software programs boot in a relatively small amount of time (e.g., 3 seconds) as compared to the  
15           cellular software programs which boot in a relatively large amount of time (e.g.,  $\geq 15$  seconds).

          As shown in FIG. 4, the boot software routine **400** begins at **402** and continues with **404**. In step **404**, the hybrid unit's hardware (e.g., the hardware of FIG. 2) is initialized in a conventional manner. This step can involve loading a boot infrastructure into a memory (e.g., memory **214** and/or **216** of FIG. 2) and subsequently executing the boot infrastructure. A boot  
20           infrastructure is well known to persons skilled in the art. Thus, a boot infrastructure will not be described in detail herein. Still, it should be understood that a boot infrastructure includes code to apply power to hardware and to configure hardware needed to load and execute a boot program. Once the hardware is initialized, a boot manager program is loaded into memory as shown by step **406**. After loading the boot manager program into memory, the boot software  
25           routine **400** continues with step **408**. In step **408**, the boot manager program is executed. Next, step **410** is performed where the boot software routine **400** returns to step **402**.

          Boot manager programs are well known to persons skilled in the art. Thus, boot manager programs will not be described in detail herein. The boot manager program coordinates the boot process such that software programs can be loaded in a given order. A person skilled in  
30           the art will appreciate that a boot manager is one embodiment of a program for enabling a boot



of a hybrid unit. The invention is not limited in this regard, and any other boot program (e.g., a dual boot utility program) can be used without limitation.

FIG. 5 is a flowchart of a software routine for the execute boot manager program step 408 of FIG. 4. The software routine begins at 502 and continues with steps 504-506 and steps 508-516. Steps 504-506 are performed to provides critical LMR communication capabilities to a user almost instantaneously upon power up or a re-boot of a hybrid unit (e.g., hybrid unit 106 or 108 of FIG. 1). The critical LMR communication capabilities include, but are not limited to, radio communications with individual remote radios or a group of remote radios associated with members of a talkgroup. The critical LMR communication capabilities will become more evident as the discussion progresses. Accordingly, step 504 involves loading an LMR unit program code into memory (e.g., memory 214 of FIG. 2). Step 506 involves executing the LMR unit program code. As a consequence of executing the LMR unit program code a real-time operating system is loaded and executed by an LMR processor (e.g., LMR processor 250 of FIG. 2).

In contrast, steps 508-516 are performed to get the hybrid unit fully operational. As such, step 508 involves loading a cellular unit program code into memory (e.g., memory 216 of FIG. 2). Step 510 involves executing the cellular unit program code. As a result of executing the cellular unit program code, a mobile operating system is loaded into memory and executed by a cellular processor (e.g., cellular processor 252 of FIG. 2). Thereafter, handoff program code is loaded into memory (e.g., memory 214 and/or 216 of FIG. 2). The handoff program code is generally operative to transfer control of the critical LMR functionalities from an LMR processor (e.g., LMR processor 250 of FIG. 2) to a cellular processor (e.g., cellular processor 252 of FIG. 2). The handoff program code is then executed in step 514. Upon completing step 514, the software routine returns to step 502.

FIG. 6 is a flowchart of a software routine for the execute LMR unit program code 506 of FIG. 5. The software routine begins at step 602 and continues with steps 604. Step 604 involves loading device driver software programs (e.g., device driver software programs 312-1, 312-2, . . . , 312-N of FIG. 3) into a memory (e.g., memory 214 of FIG. 2) of an LMR processor (e.g., LMR processor 250 of FIG. 2). The device driver software programs can include control

code for a pre-defined transceiver (e.g., transceiver **206** of FIG. 2), a pre-defined antenna (e.g., antenna **202** of FIG. 2), and a pre-defined frequency synthesizer (not shown).

In a next step **606**, a real-time operating system is loaded into the memory of the LMR processor. Notably, the real-time operating system is a separate operating system than that loaded in step **510** of FIG. 5. Once the real-time operating system is loaded into memory, LMR software programs and LMR service software programs (e.g., platform devices and services **308** of FIG. 3) are loaded into the memory, as shown by step **608**. The LMR software programs can include instructions for controlling hardware of an LMR processor (e.g., LMR processor **250** of FIG. 2), first stage input devices (e.g., first stage input devices **262** of FIG. 2), and/or first stage output devices (e.g., first stage output devices **272** of FIG. 2). FIG. 7 provides a schematic illustration that visually highlights, via relatively thick black lines, which hardware of a hybrid unit is controlled by such LMR software programs. The LMR services software programs can include instructions for providing services such as encryption, decryption, and fault management. After the LMR device/service software programs are loaded into memory, at least one installed application is launched in step **610** which facilitates the provisions of critical LMR functionalities. In this regard, the installed application can include a software program for channel control and waveform configuration. In step **612**, the software routine **506** returns to step **602**.

FIG. 8 is a flowchart of a software routine for the execute cellular unit program code step **510** of FIG. 5. The software routine begins at step **802** and continues with steps **804**. Step **804** involves loading device driver software programs (e.g., device driver software programs **312-1, 312-2, . . . , 312-N** of FIG. 3) into a memory (e.g., memory **216** of FIG. 2) of a cellular processor (e.g., LMR processor **252** of FIG. 2). The device driver software programs can include control code for a pre-defined transceiver (e.g., transceiver **208** of FIG. 2) and a pre-defined antenna (e.g., antenna **204** of FIG. 2).

In a next step **606**, a mobile operating system is loaded into the memory of the cellular processor. Notably, the mobile operating system is a separate operating system than that loaded in step **606** of FIG. 6. Once the mobile operating system is loaded into memory, cellular software programs and cellular service software programs (e.g., platform devices and services **308** of FIG. 3) are loaded into the memory, as shown by step **808**. The cellular software

programs can include instructions for controlling hardware of a cellular processor (e.g., cellular processor **252** of FIG. 2), second stage input devices (e.g., second stage input devices **260** of FIG. 2), second stage output devices (e.g., first stage output devices **270** of FIG. 2) and/or GPS equipment (e.g., GPS components **218, 220** of FIG. 2). FIG. 9 provides a schematic illustration that visually highlights, via relatively thick black lines, which hardware of a hybrid unit is controlled by such cellular software programs. The cellular services software programs can include instructions for providing services such as encryption, decryption, and fault management. After the cellular device/service software programs are loaded into memory, at least one installed application is launched in step **810** which facilitates the provisions of cellular communication functionalities, personal digital assistant functionalities, portable media player functionalities, digital camera functionalities, video camera functionalities, location tracking functionalities, web browser functionalities, and touch screen functionalities. In step **812**, the software routine **510** returns to step **802**.

Notably, the software routine of FIG. 8 can include more or less steps than that shown. For example, in some scenarios, the software routine of FIG. 8 can include a step in which a boot status is displayed on a front display (e.g., front display **242** of FIG. 2) through out at least a portion of the time it takes to get at least the cellular processor (e.g., cellular processor **252**) fully operational. The software routine of FIG. 8 can also include a step in which a PTT service loads and an LMR radio status is displayed on the front display. These additional steps can be performed prior to any handoff operations (e.g., steps **512-514** of FIG. 5).

FIG. 10 is a flowchart of a software routine for the execute handoff program code step **514** of FIG. 5. The software routine begins at step **1002** and continues with steps **1004**. Step **1004** involves performing operations by a cellular processor (e.g., cellular processor **252** of FIG. 2) to notify an LMR processor (e.g., LMR processor **250** of FIG. 2) that it is ready to accept control of critical LMR functionalities. In response to such a notification, the LMR processor performs operations in step **1006** to determine when it is an appropriate time to hand over control of the LMR functionalities to the cellular processor. The criteria on which this determination is made can be pre-defined or customized by a user of the hybrid unit. In some scenarios, this determination is based on the operating state of the LMR processor and the activity of the LMR processor. For example, if the LMR processor is currently handing a talkgroup call, then it may decide that now is not an appropriate time to hand over control of the LMR functionalities. If a

determination is made that it is not an appropriate time to hand over control of the LMR functionalities [1008:NO], then the software routine returns to step 1006. In contrast, a determination can be made that now is an appropriate time to hand over control of the LMR functionalities when the LMR processor is not performing any LMR communication operations.

5 If such a determination is made that it is an appropriate time to hand over control of the LMR functionalities [1008:YES], then the software routine continues with step 1010 where control of the LMR functionalities are handed over to the cellular processor. As a consequence of this hand over, the cellular processor acts as a master processor and the LMR processor acts as a slave processor, as shown by step 1012.

10 As a slave processor, the LMR processor monitors activities of the cellular processor for purposes of detecting a system crash, as shown by step 1014. If a system crash has not been detected [1016:NO], then the software routine returns to step 1014. If a system crash has been detected [1016:YES], then the LMR processor re-takes control in step 1018 over the LMR functionalities and hardware peripherals. The LMR processor also re-sets or re-boots the cellular  
15 processor so as to bring it to an initial state, as shown by step 1020. Upon completing step 1020, step 1022 is performed where the software routine returns to step 1004.

In view of the forgoing, the present invention provides a hybrid unit in which a seamless merging of critical hardware availability occurs with a full featured mobile operating system. Also, the hybrid unit is able to rapidly and automatically recover from any system crash.

20 As such, the hybrid unit overcome various drawbacks of conventional LMR radios and conventional cellular phones (e.g., Smartphones).

All of the apparatus, methods and algorithms disclosed and claimed herein can be made and executed without undue experimentation in light of the present disclosure. While the invention has been described in terms of preferred embodiments, it will be apparent to those of  
25 skill in the art that variations may be applied to the apparatus, methods and sequence of steps of the method without departing from the concept, spirit and scope of the invention. More specifically, it will be apparent that certain components may be added to, combined with, or substituted for the components described herein while the same or similar results would be achieved. All such similar substitutes and modifications apparent to those skilled in the art are  
30 deemed to be within the spirit, scope and concept of the invention as defined.

## CLAIMS

1. A method for operating a hybrid communication device, comprising:
  - a) executing at least one boot program;
  - b) responsive to the boot program, concurrently executing a first code for booting at least a real-time operating system on which a radio processor of the hybrid communication device is built and a second code for booting at least a mobile operating system on which a cellular processor of the hybrid communication device is built;
  - c) providing with the radio processor support for wireless radio communication functionalities while the mobile operating system is booting; and
  - d) executing a third code for transferring control of the wireless radio communication functionalities and a first portion of the input and output devices from the radio processor to the cellular processor, after the mobile operating system has fully booted.
2. The method according to claim 1, further comprising controlling by the radio processor only a first portion of a plurality of input and output devices of the hybrid communication device that are necessary for providing the wireless radio communication functionalities, while the mobile operating system is booting.
3. The method according to claim 1, further comprising performing operations by the cellular processor to notify the radio processor that it is ready to accept control of the wireless radio communication functionalities.
4. The method according to claim 3, further comprising performing operations by the radio processor to determine when to transfer control of the wireless radio communication functionalities to the cellular processor based on a pre-defined criteria.
5. The method according to claim 4, wherein the pre-defined criteria comprises an operating state of the radio processor and a current activity of the radio processor.
6. The method according to claim 1, further comprising monitoring, by the radio processor, activities of the cellular processor to detect a system crash.
7. The method according to claim 6, further comprising performing operations by the radio processor to re-take control of the wireless radio communication functionalities when a system crash is detected.

8. The method according to claim 6, further comprising performing operations by the radio processor to re-set the cellular processor so as to bring it to an initial state, when a system crash is detected.

9. A hybrid communication device, comprising:

a radio processor configured to provide wireless radio communication functionalities;

a cellular processor configured to provide support for cellular communication functionalities; and

at least one electronic circuit configured to concurrently execute a first code for booting at least a real-time operating system on which the radio processor is built and a second code for booting at least a mobile operating system on which the cellular processor is built;

wherein the radio processor is configured to provide support for the wireless radio communication functionalities while the mobile operating system is booting;

wherein said at least one electronic circuit is configured to execute a third code for transferring control of the wireless radio communication functionalities and a first portion of the input and output devices from the radio processor to the cellular processor, after the mobile operating system has fully booted.

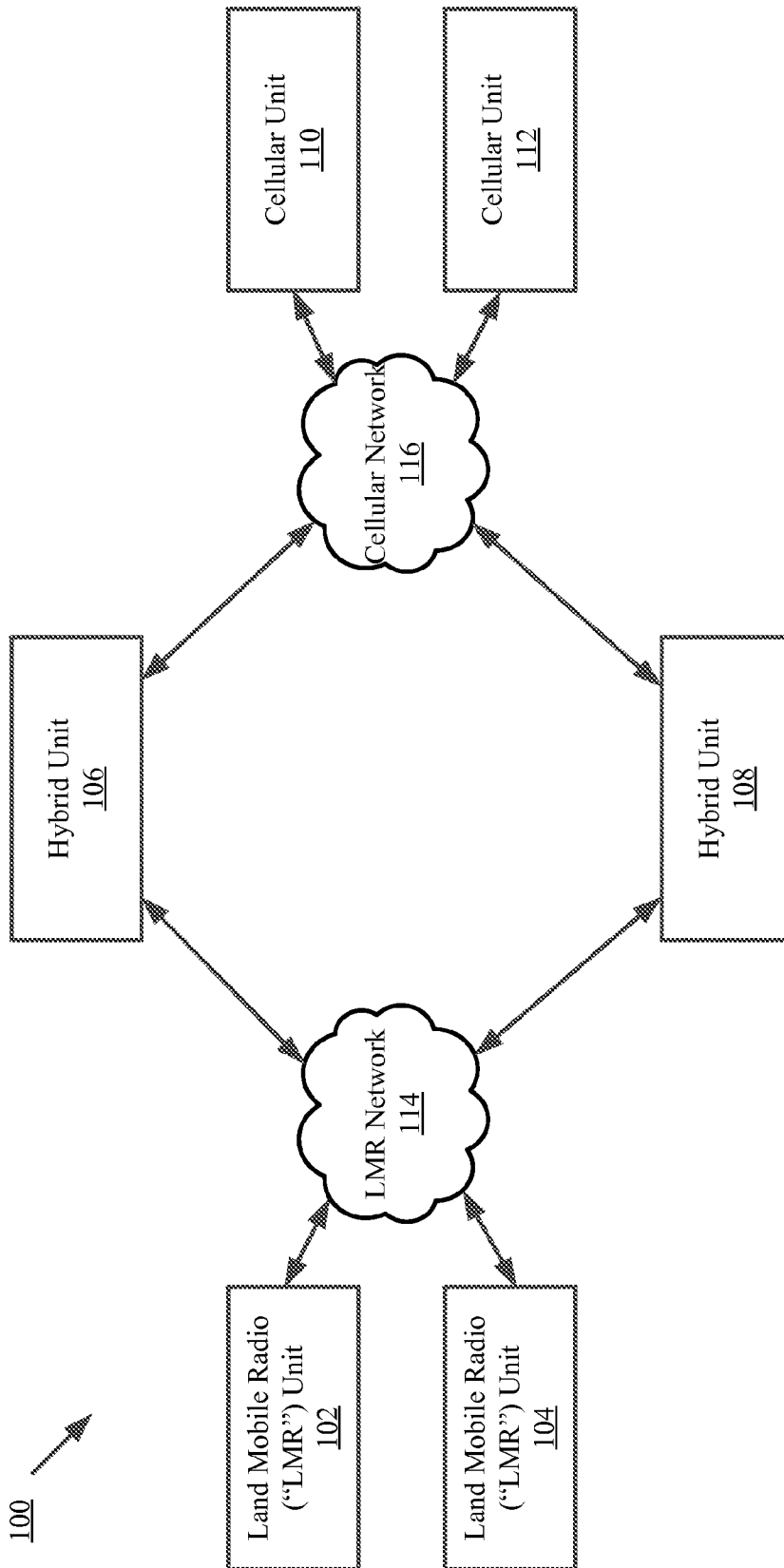

FIG. 1

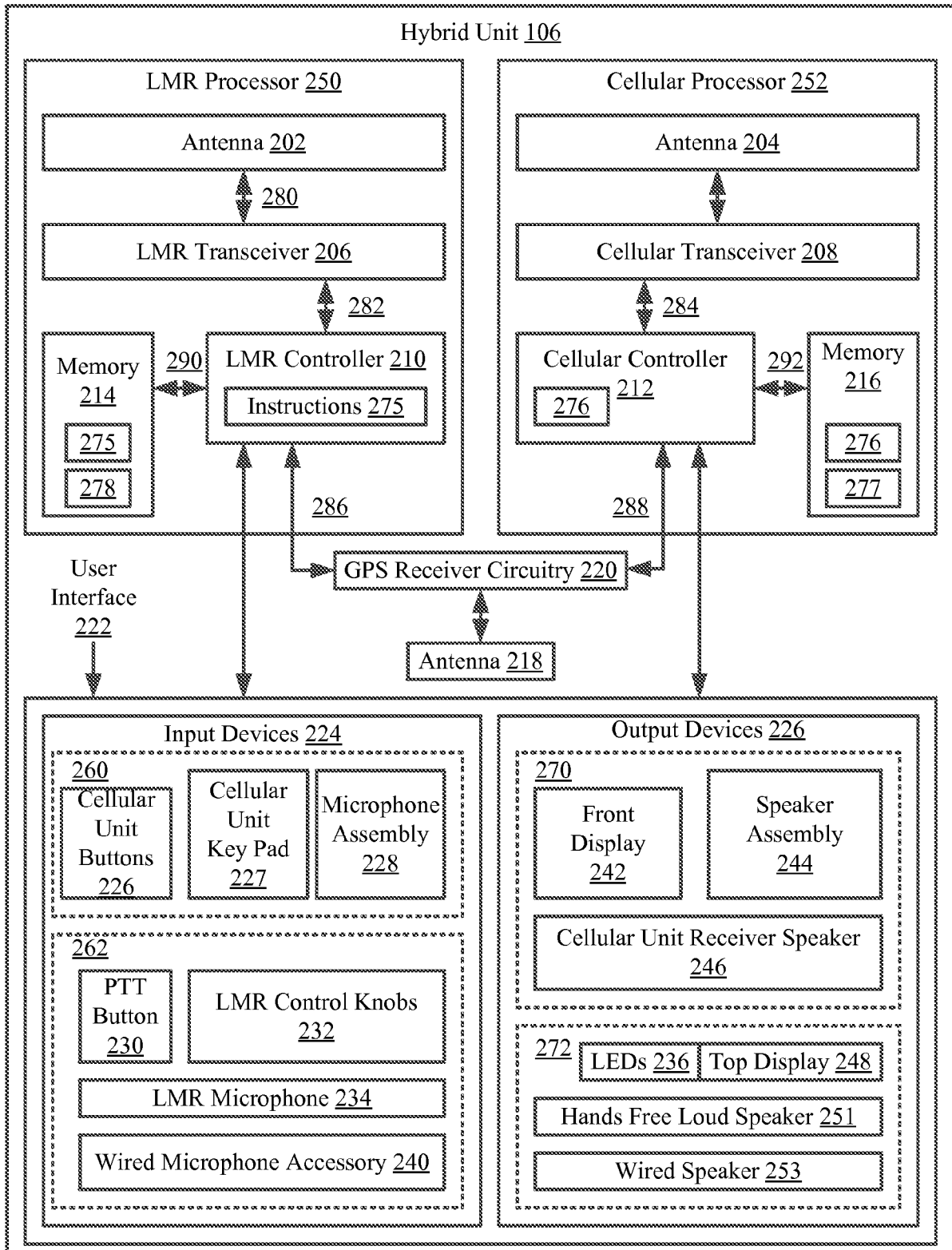

FIG. 2



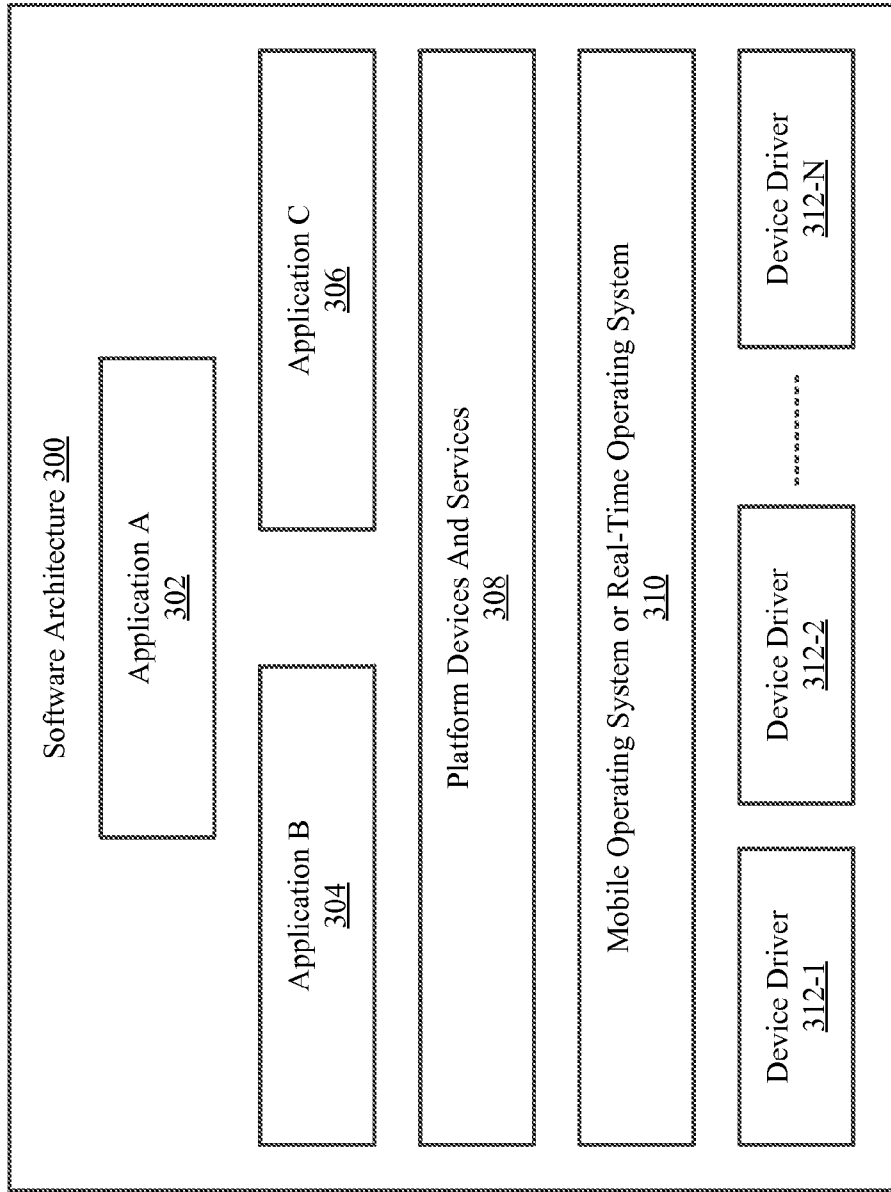

FIG. 3

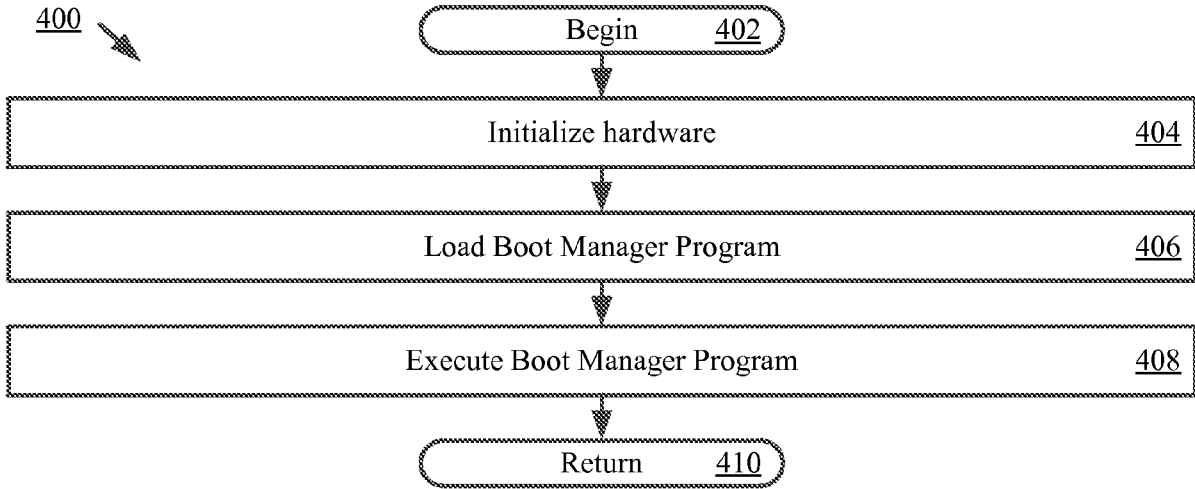

FIG. 4

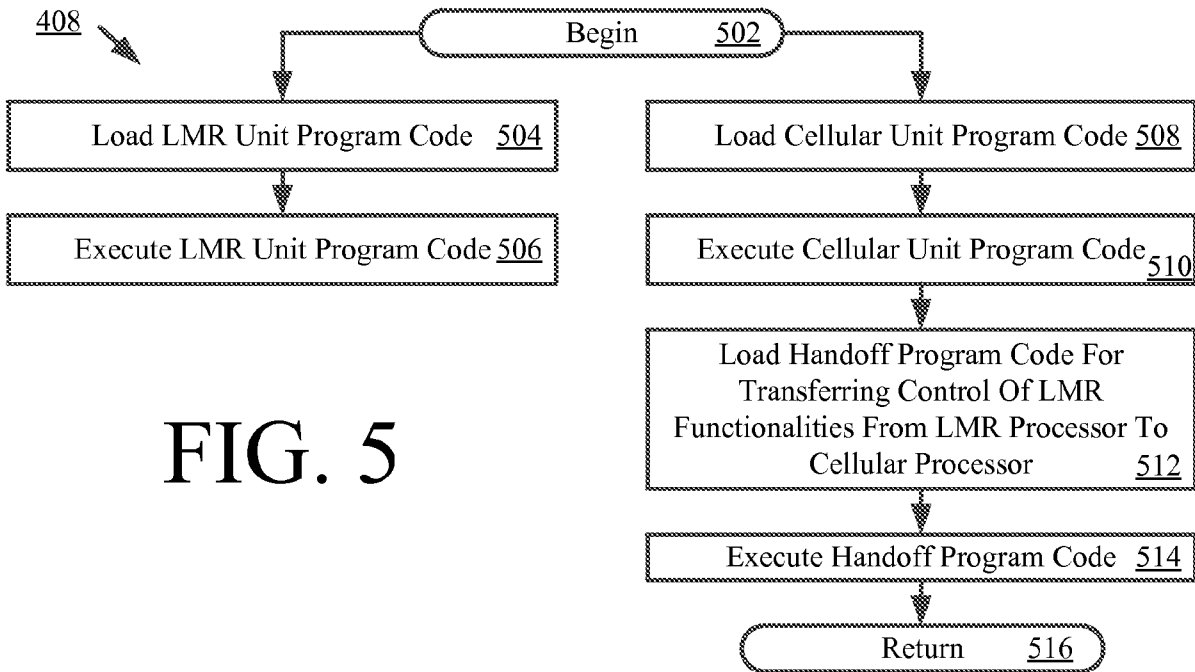

FIG. 5

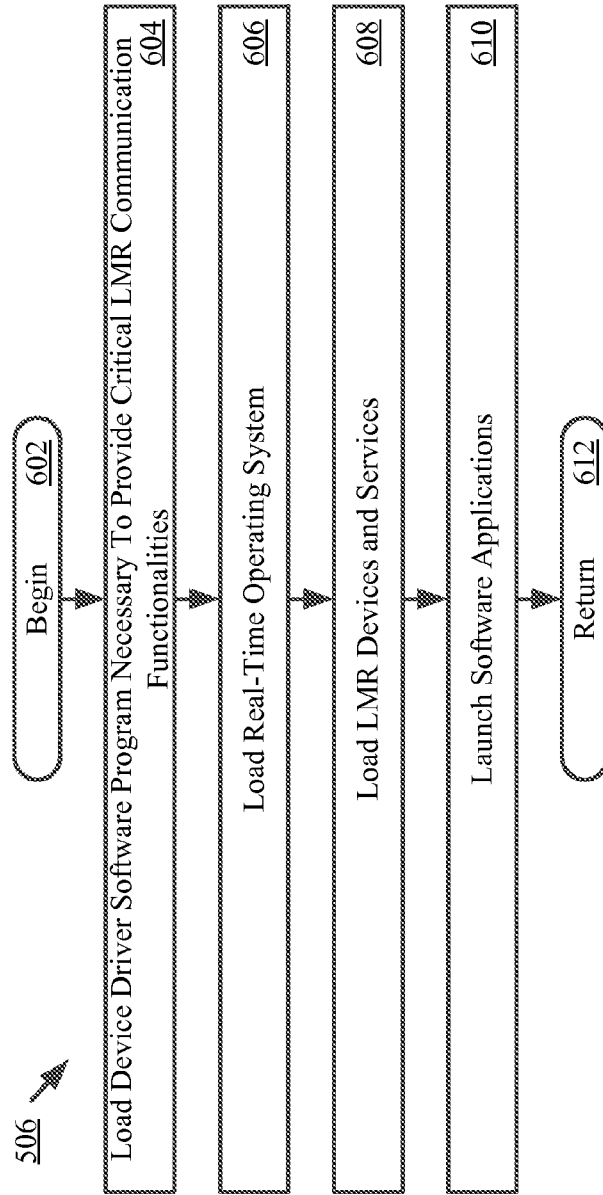

FIG. 6

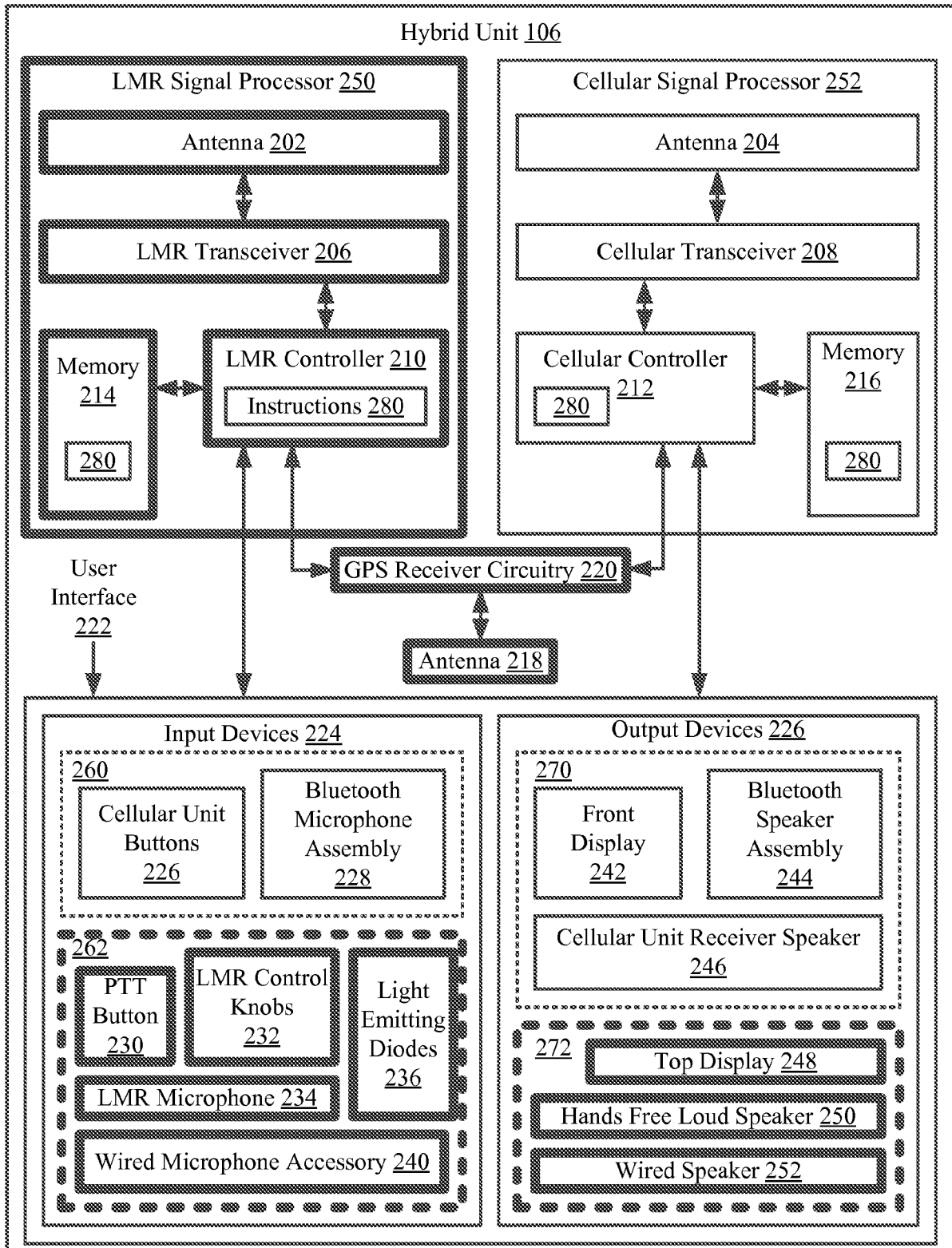

FIG. 7

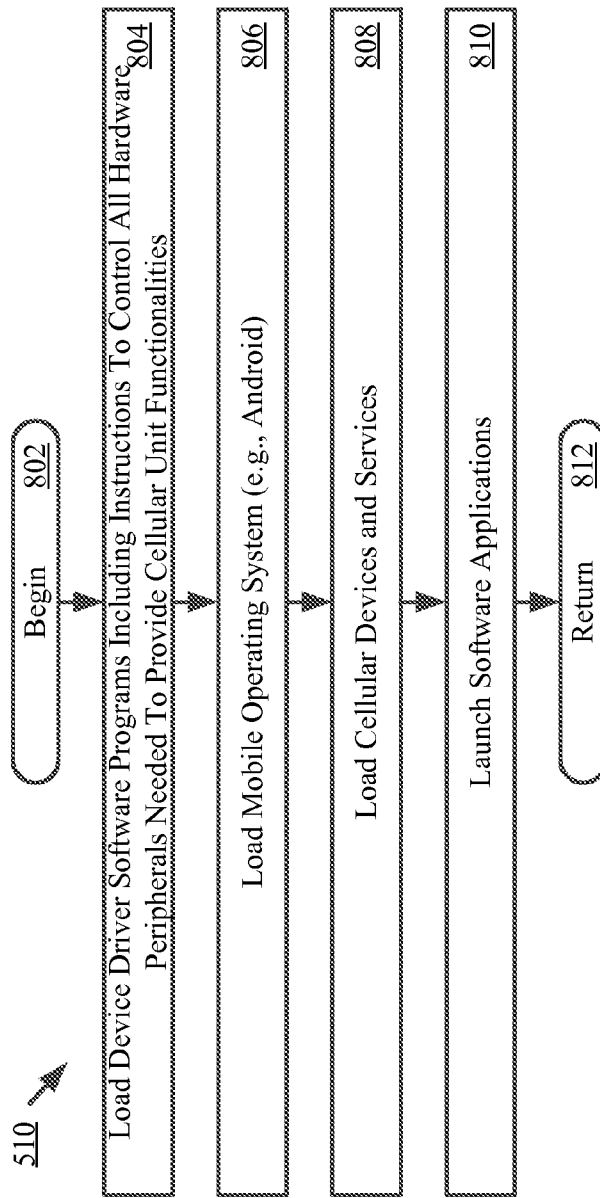

FIG. 8

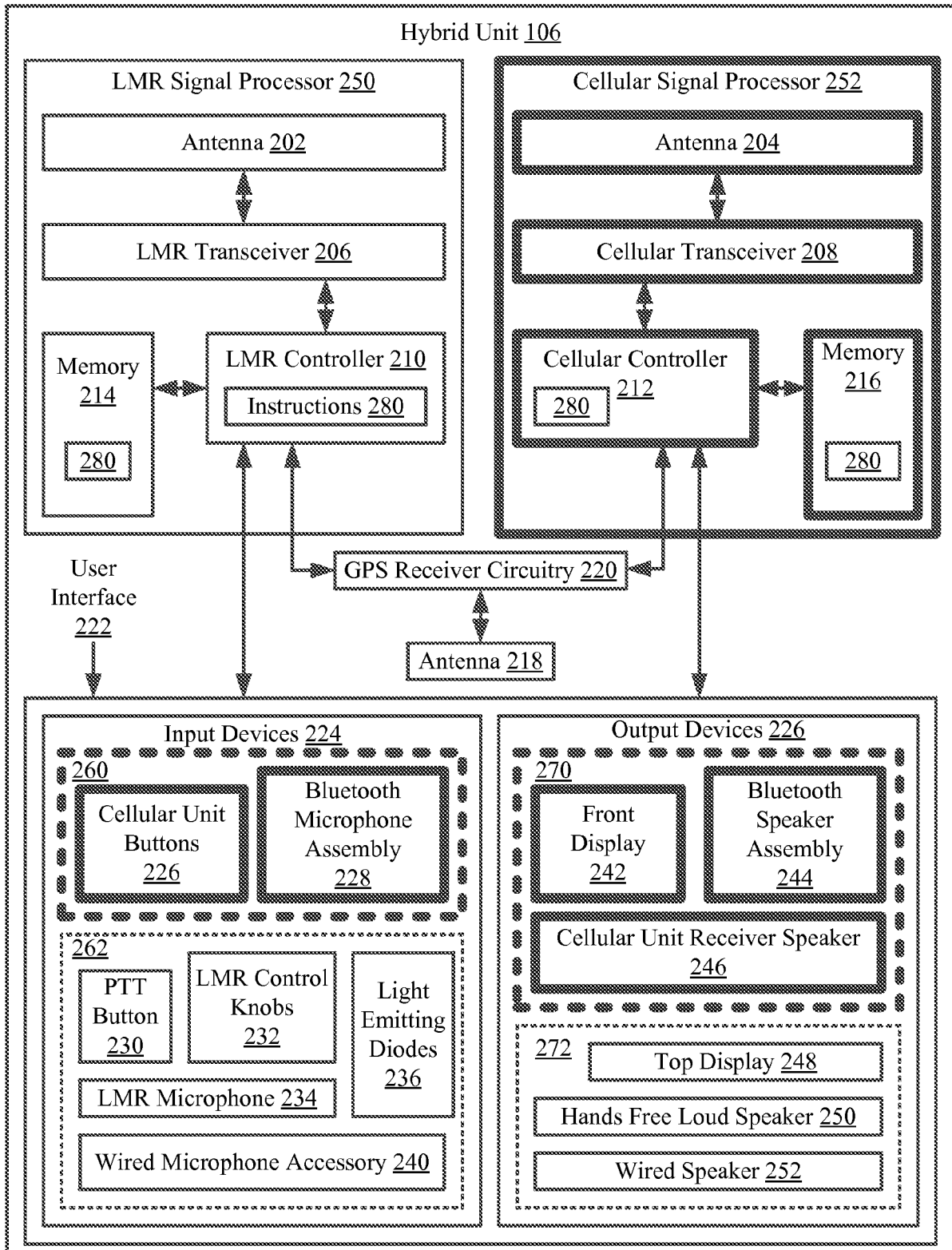

FIG. 9

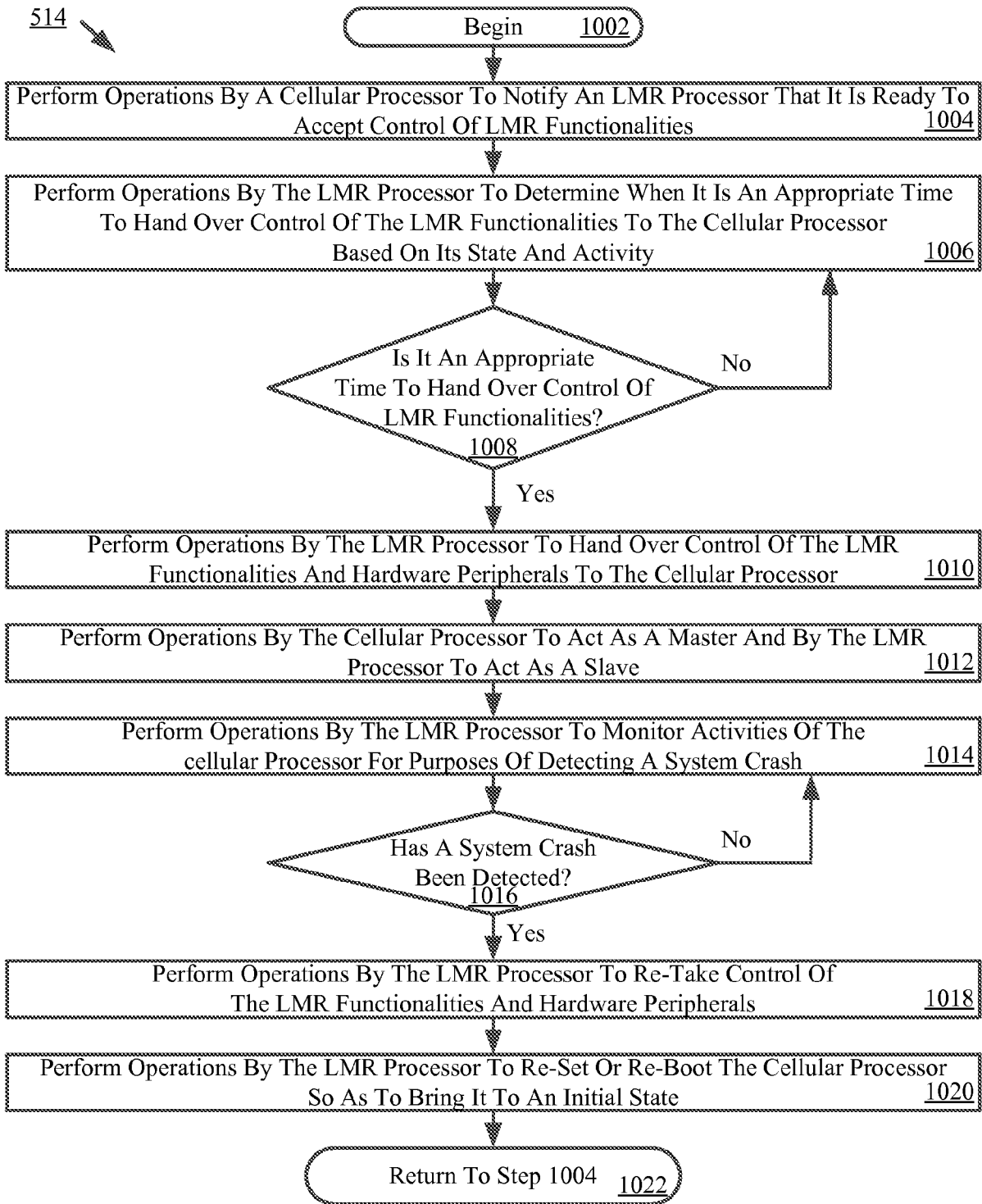
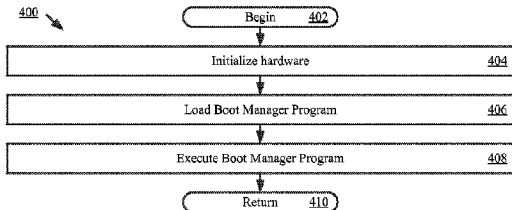

FIG. 10

400



408

