

[72] Inventors **Anthony R. Mennuto**
769 Pascack Road, Paramus, N.J. 07652;
Nicholas Popovich, Teaneck, N.J.
 [21] Appl. No. **807,859**
 [22] Filed **Mar. 17, 1969**
 [45] Patented **Aug. 17, 1971**
 [73] Assignee **said Anthony R. Mennuto, by said Nicholas Popovich**

3,321,885	5/1967	Pratt.....	160/381 X
916,128	3/1909	Ellis.....	52/619
1,601,519	9/1926	Young.....	52/619 X
2,511,108	6/1950	Hansen.....	160/90
2,702,595	2/1955	Rumbaugh et al.....	160/90
2,736,401	2/1956	Milone.....	160/90 X
2,796,959	6/1957	Toney.....	52/619
2,948,366	8/1960	Kelly et al.....	49/501
3,177,924	4/1965	McPhail.....	160/91
3,254,465	6/1966	Brengman et al.....	52/455
3,389,505	6/1968	Zitomer.....	52/455 X
3,403,953	10/1968	Clark.....	49/501 X

[54] **INSULATED STORM DOOR ASSEMBLY**
 3 Claims, 11 Drawing Figs.

[52] U.S. Cl. **160/90,**
 49/501, 52/456, 52/623

[51] Int. Cl. **E06b 3/32**

[50] Field of Search 160/90, 91,
 92, 381; 49/501, 503; 52/619, 620, 621, 623, 615,
 455, 456

[56] **References Cited**
UNITED STATES PATENTS

2,628,678 2/1953 Webster 160/90

Primary Examiner—David J. Williamowsky
Assistant Examiner—Philip C. Kannan
Attorney—Anthony F. Cuoco

ABSTRACT: A storm door assembly mounted to an installation structure and including an insulating core sandwiched between a pair of one-piece panels. An opening in the upper portion of the door assembly accepts a frame. The frame is adapted for receiving screen and glass inserts, and which inserts are adapted for retaining a decorative grill.

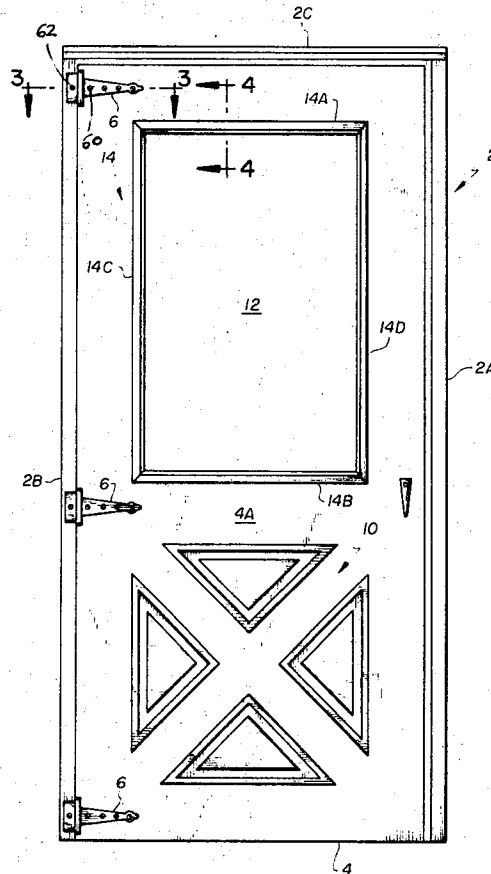

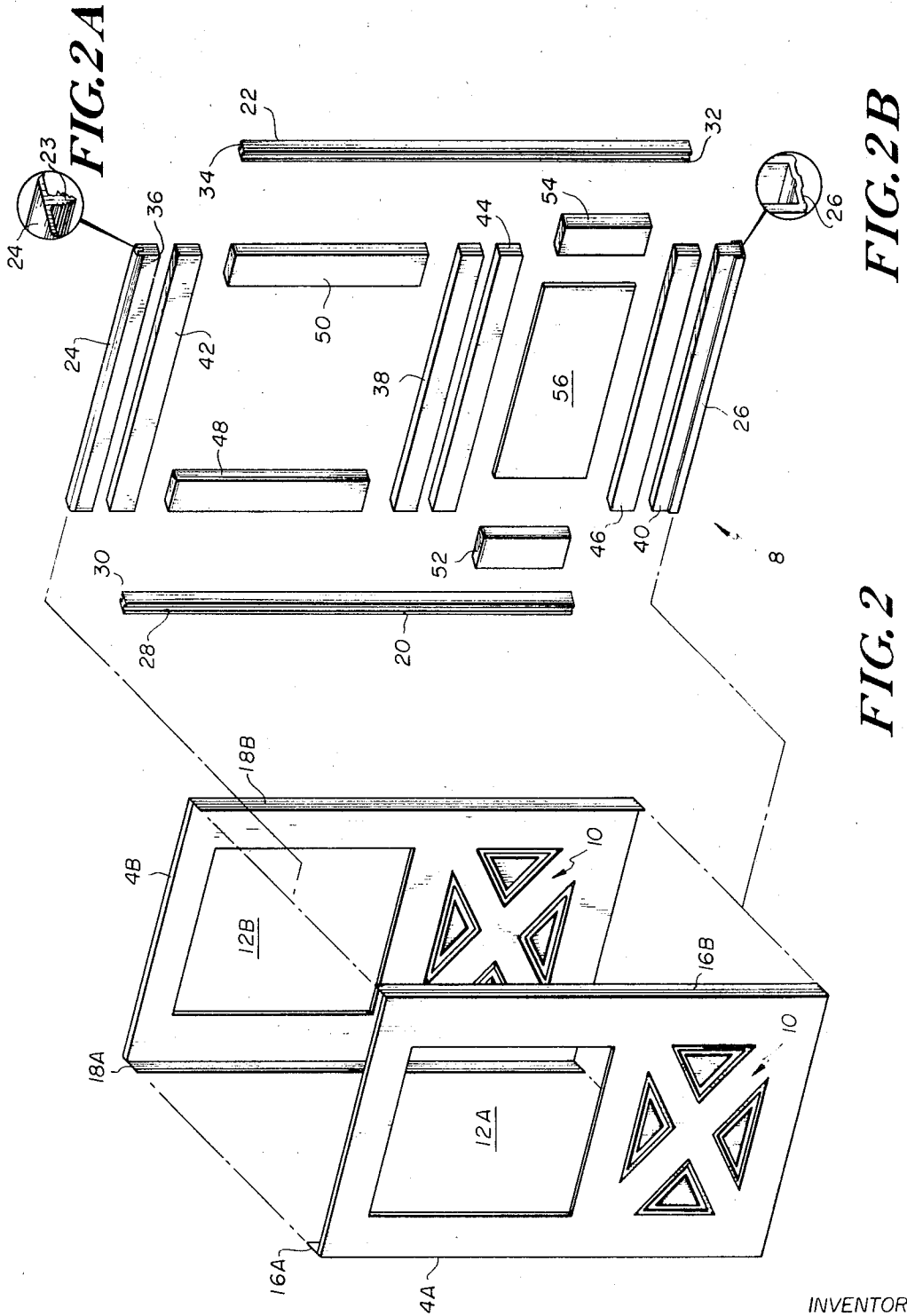

FIG. 2B

FIG. 2

INVENTORS
ANTHONY R. MENNUTO
NICHOLAS POPOVICH

BY

ATTORNEY

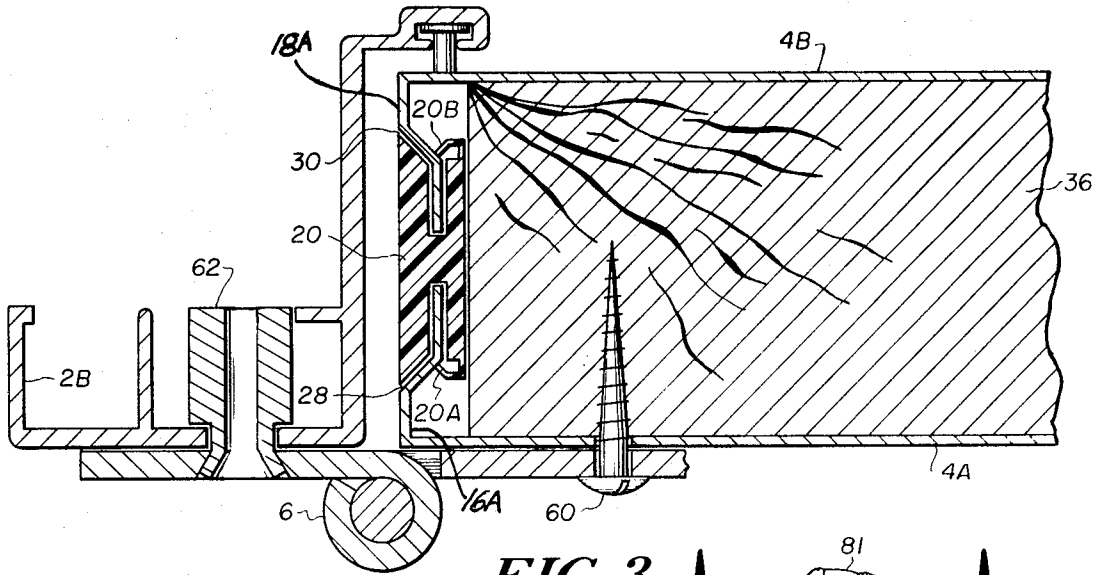

FIG. 3

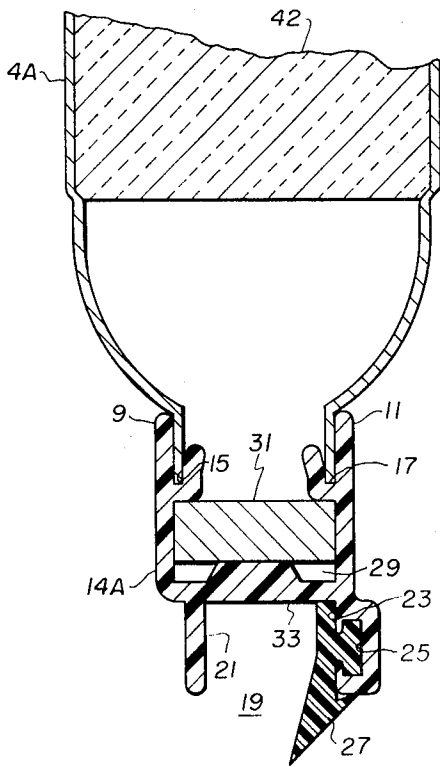

FIG. 4

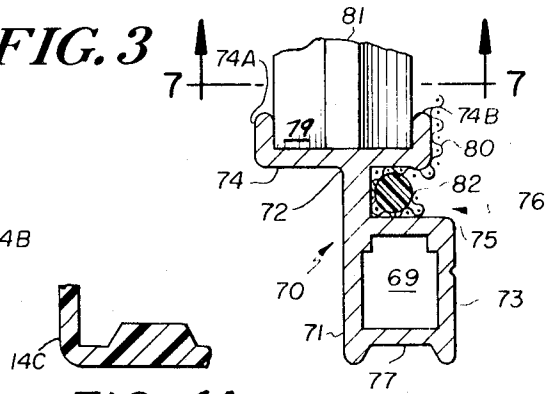

FIG. 4A

FIG. 5

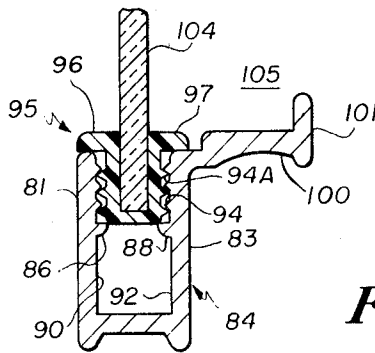

FIG. 6

INVENTORS
ANTHONY R. MENNUTO
NICHOLAS POPOVICH

BY

Anthony J. Lucas

ATTORNEY

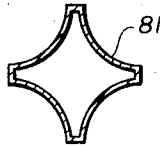

FIG. 7

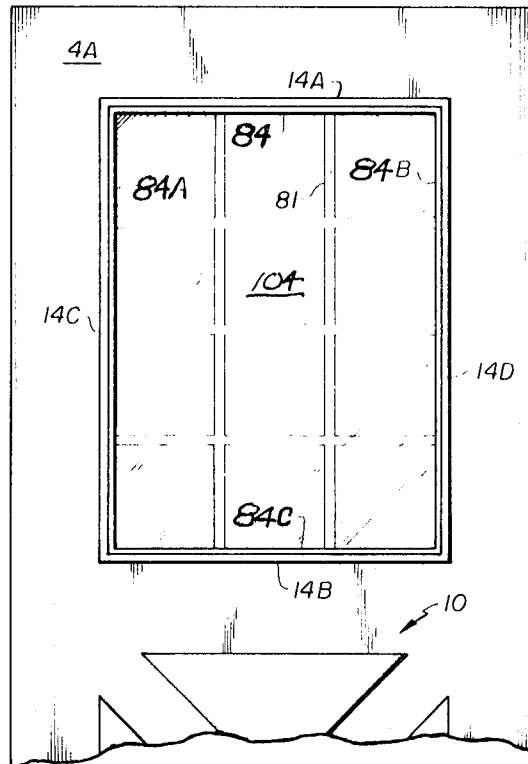

FIG. 8

INVENTORS
ANTHONY R. MENNUTO
NICHOLAS POPOVICH

BY

Anthony R. Mennuto

ATTORNEY

INSULATED STORM DOOR ASSEMBLY

BACKGROUND OF THE INVENTION

1. Field of the Invention

This invention relates to storm doors having screen and glass inserts and, more particularly, to storm doors of the type described having an insulating core for improved thermal and sound insulating characteristics.

2. Description of the Prior Art

Heretofore, storm doors of the type described have included metallic panels having extrusions for receiving screen and glass inserts and a separate kick plate secured to the lower portion of the door. The inserts have been known to rattle and the kick plate frequently becomes loose. All of this tends toward untimely degradation of the utility and appearance of the door. Moreover, the thermal insulating and sound insulating characteristics of these doors are less than desirable.

SUMMARY OF THE INVENTION

This invention contemplates a storm door hinged to an installation structure and including a core sandwiched between a pair of one-piece panels. The core includes top and bottom members and a pair of side members for supporting the panels. The top, bottom and side members surround a plurality of insulating members and a plurality of discretely disposed structural members for supporting the hinges. The upper portion of the panel and core sandwich has an opening which accepts a frame, and which frame has top, bottom and side members of a selected shape for securely retaining screen and glass inserts. The inserts, in turn, are adapted for retaining a decorative grill.

The main object of this invention is to provide a novel storm door including a thermal and sound insulating core sandwiched between a pair of one-piece panels.

Another object of this invention is to provide novel means for supporting the panels.

Another object of this invention is to provide novel means for hinging the door to the installation structure.

Another object of this invention is to provide a novel frame for retaining the core and panels to define an opening in the upper portion thereof, and for retaining screen and glass inserts in the opening.

Another object of this invention is to securely retain the inserts to eliminate rattling thereof.

Another object of this invention is to provide the inserts for retaining a decorative grill.

These and other objects and features of the invention are pointed out in the following description in terms of the embodiments thereof which are shown in the accompanying drawings. It is to be understood, however, that the drawings are for the purpose of illustration only and are not a definition of the limits of the invention, reference being had to the appended claims for this purpose.

DESCRIPTION OF THE DRAWINGS

In the drawings, wherein corresponding numerals indicate corresponding parts:

FIG. 1 is a pictorial representation showing a storm door and installation frame according to the invention.

FIG. 2 is an isometric assembly view showing the panels and core members according to the invention.

FIG. 2A is an enlarged isometric end view showing a top cap core member according to the invention.

FIG. 2B is an enlarged isometric end view showing a bottom expander core member according to the invention.

FIG. 3 is a sectional view of the storm door of FIG. 1 showing in substantial detail the novel hinging means and panel supporting means of the invention.

FIG. 4 is a partial sectional view of the storm door of FIG. 1 showing a section of the upper member of the frame for retaining the panels and core to define an opening in the upper portion thereof, and

FIG. 4A is a sectional view of the side member of the frame for retaining the interchangeable screen and glass inserts.

FIG. 5 is a sectional view of the screen insert of the invention and the decorative grill retained therein.

FIG. 6 is a sectional view of the glass insert of the invention.

FIG. 7 is a sectional view of the decorative grill shown in FIG. 5.

FIG. 8 is a pictorial representation of the decorative grill, glass insert and frame of the invention.

DESCRIPTION OF THE INVENTION

FIG. 1 shows an installation structure 2 having a pair of side members 2A and 2B commonly known in the art and hereinafter referred to as Z-bars. Structure 2 has an upper member or raincap 2C extending across the top of and suitably secured to Z-bars 2A and 2B.

The door assembly 4 is hinged by hinges 6 to one of the Z-bars such as the Z-bar 2B. Door assembly 4 includes a one-piece panel 4A shown in FIGS. 1 and 2, and a one-piece panel 4B and a core 8 shown in FIG. 2. The lower portions of panels 4A and 4B include embossed designs such as the crossbucks 10, and which lower portions otherwise serve as kick plates. The upper portions of the panels include rectangular openings 12A and 12B which cooperate upon assembly to form opening 12 shown in FIG. 1. Opening 12 receives a rectangular frame 14 having upper and lower members 14A and 14B and side members 14C and 14D, and which members 14A, 14B, 14C and 14D may be keyed or otherwise suitably fastened together to form a rigid rectangular frame for surrounding opening 12 and for accepting rectangular screen and glass inserts as will hereinafter be described.

With reference to FIG. 2, panel 14A has a pair of elongated rearwardly extending side members 16A and 16B and panel 4B has a similar pair of elongated rearwardly extending side members 18A and 18B. Panels 4A and 4B are supported at members 16A and 16B and members 18A and 18B, respectively, in a manner as will hereinafter be shown with reference to FIG. 3.

It is to be noted that panels 4A and 4B are one-piece stampings of aluminum or some other such similar metal, with the method for providing one-piece stampings of this size and shape being outside the scope of this invention. It will suffice to say for purposes of describing the invention that there is thus provided a unitary type panel which eliminates the disadvantages of multimembered door panels now known in the art, to wit: loosening of kick plates, loosening and breaking of molding, sagging, splitting, racking, etc.

Core 8 shown in FIG. 2 includes a pair of side caps 20 and 22, a top cap 24 and a bottom expander 26. The top and side caps and bottom expander may be, by way of example but not by way of limitation, of a rigid vinyl or other similar material having suitable insulating properties. Side caps 20 and 22 correspond in length to panels 4A and 4B and have slots 28 and 30 and slots 32 and 34, respectively. Slots 28 and 30 extend the length of side cap 20 on the front and rear surfaces thereof, respectively, and slots 32 and 34 extend the length of side cap 22 on the front and rear surfaces thereof, respectively. Side members 16A and 16B of panel 4A are engaged in slots 28 and 32 and side members 18A and 18B of panel 4B are engaged in slots 30 and 34 so that the panels are supported by side caps 20 and 22 as will be further explained.

Side caps 20 and 22, top cap 24 and bottom expander 26 surround separators 36, 38 and 40, and insulating members 42, 44, 46, 48, 50, 52, 54, and 56 of core 8.

Separators 36, 38 and 40 may be, by way of example but not by way of limitation, of a commercially available high density pressed wood composition and are discretely positioned along the length of core 8 so that hinges 6 may be fastened thereto for mounting door 4 to installation structure 2.

Insulating members 42, 44, 46, 48, 50, 52, 54 and 56 may be, by way of example but not by way of limitation, of a commercially available foam plastic insulating composition and are positioned to cooperate with the separators, side and top

caps and bottom expander to form core 8. As will be seen by referring to FIG. 2, core 8 is sandwiched between panels 4A and 4B with insulating members 42, 48 and 50 and separator 38 defining an opening corresponding to openings 12A and 12B in panels 4A and 4B, respectively. It will now be evident to those skilled in the art that the size, shape and number of separators and insulating members shown and described herein are for illustration purposes only and variations thereof to accommodate particular applications are within the spirit and scope of the invention.

It is to be noted that insulating member 56 corresponds in size substantially to that of crossbucks 10. In order to accommodate the crossbuck embossing on the rear faces of panels 4A and 4B, i.e. the faces adjacent core 8, insulating member 56 should be of a suitably resilient material to deform when in contact with the embossing or, alternatively, may be of a reduced thickness as shown in FIG. 2 so as to provide adequate clearance for said embossing.

As shown in FIG. 2A, top cap 24 is channel shaped for receiving separator 36 and has a fish hook type member 23 for securing the cap to the separator, and bottom expander 26 is channel shaped for receiving separator 40 as shown in FIG. 2B. The channels of top cap 24 and bottom expander 26 are wide enough to receive not only separators 36 and 40, respectively, but also to receive and rigidly retain the top and bottom edges of panels 4A and 4B therein. Separators 36, 38 and 40 and insulating members 42, 44, 46, 48, 50, 52, 54 and 56 may be cemented or otherwise secured to the rear surfaces of panels 4A and 4B, with side members 18A and 18B of panel 4B engaged in slots 30 and 34, respectively, of side caps 20 and 22, the top and bottom edges of the panels engaged in the channels of top cap 24 and bottom expander 26 as heretofore noted, and side members 16A and 16B of panel 4A engaged in slots 28 and 32, respectively, of side caps 20 and 22 to provide the sandwiched panel and core door assembly. It will be seen that with a door assembly of the type described there is no metal to metal contact and thus the thermal, as well as sound insulating, features of the door are superior to storm doors now known in the art.

In the sectional view of FIG. 3 the panel supporting feature of side caps 20 and 22 is illustrated, and wherein side member 16A of panel 4A and side member 18A of panel 4B are engaged in slots 28 and 30 of side cap 20. Thus, slots 28 and 30 are seen to oppose each other and to extend toward the center of side cap 20, first angularly and then generally parallel to the lateral edges thereof. Side members 16A and 18A of panels 4A and 4B are formed to generally follow the shape of the slots so as to be retained therein upon engagement of the side members in the slots. Additionally, side cap 20 has elongated tabs 20A and 20B extending angularly to the threshold of slots 28 and 30, respectively, and substantially normal to side members 16A and 18A to provide a captivating action upon said engagement, and thereby more positively retaining the side members in the slots. It will now be understood that side members 16B and 18B of panels 4A and 4B are likewise engaged and captivated in slots 32 and 34 of side cap 22.

FIG. 3 shows one of the hinges 6 fastened by a screw 60 extending through panel 4B to separator 36. Hinges 6 are secured to Z-bar 2B through a hollow rivet 62. Thus, hinges 6 may be prelocated and preassembled to the installation frame to prevent loss or mutilation of the hinges 6 during shipping, as well as to promote faster and more accurate installation. These features have wide appeal to the home repair and improvement markets and to a significant extent enhance the utility of the invention.

As heretofore noted with reference to FIG. 1, opening 12 of door 4 receives frame 14, and which frame 14 has upper and lower members 14A and 14B and a pair of side members 14C and 14D. The frame members may be, by way of example but not by way of limitation, of a rigid vinyl material, and FIG. 4 shows for illustration purposes a section of upper member 14A.

Thus, upper member 14A has a generally H-shaped section with the upper legs 9 and 11 thereof having laterally extending parallel grooves 15 and 17, and a lower leg 23 having a laterally extending channel 25 which receives weatherstripping 27 of flexible vinyl or other suitable material. The other lower leg 21 of the H-shaped section cooperates with weatherstripping 27 for providing a track 19 for retaining screen and glass inserts as will hereinafter be shown. Panels 4A and 4B are retained in grooves 15 and 17, with insulator 42 shown sandwiched between the panels as are the other insulators and separators of core 8.

Upper legs 9 and 11 of the H-shaped section shoulder transversally toward the center of the section to form with a cross-member 33 thereof a channel 29. Channel 29 accepts a key 31 having a pair of mutually perpendicular legs and four of which such keys are provided for securing the upper, lower and side members each to the other to provide a rigid frame 14 as now will be evident.

It is to be noted that in order to enable assembly of appropriate screen and glass inserts in the frame as will be next described, leg 21 of upper member 14A must be of a predetermined length, the corresponding leg of lower member 14B must be substantially shorter and side members 14C and 14D must have no such legs at all as seen in FIG. 4A which shows, by way of example, a section of side member 14C. The members 14A, 14B, 14C and 14D are similar in all other respects.

The screen and glass inserts each include upper, lower and side members, with each such member of the screen insert having a similar section and each such member of the glass insert having a similar section. The screen and glass insert members may be, by way of example, but not by way of limitation, of extruded aluminum or other such similar and suitable material.

FIG. 5 shows a typical section of a screen insert member 70. The section has a generally O-shaped portion 69 having substantially parallel sides 71 and 73, and a substantially parallel top and bottom 75 and 77, with side 71 being elongated for forming a base member of a generally T-shaped portion 72. T-shaped portion 72 has a crossmember 74, one arm of which extends substantially parallel to the top 75 of O-shaped portion 69 for forming therewith a generally C-shaped channel 76. The end of a screen 80 is inserted in channel 76 and held firmly therein by a relatively close fitting rod shaped spline 82 of vinyl or other such suitable material. The upper, lower and side members of the screen insert are secured each to the other by keys (not shown) such as the key 31 in FIG. 4, and which keys are inserted in the center part of O-shaped portion 69 surrounded by sides 71 and 73, top 75 and bottom 77 for forming a rigid rectangular screen insert. The screen insert is assembled in frame 14 by engaging the outside faces of sides 71 and 73 of O-shaped portion 69 in the frame member track 19 formed by side 21 and weatherstripping 27 as shown in FIG. 4, and which assembly is an effective seal against dirt, dust, insects, etc.

Crossmember 74 of T-shaped portion 72 has longitudinally extending ends 74A and 74B which cooperate to form a channel 79. Channel 79 accepts and retains a decorative grill 81. A section of grill 81 is shown in FIG. 7.

FIG. 6 shows a typical section of a glass insert member 84. The section is generally U-shaped having substantially parallel sides 90 and 92. Sides 90 and 92 have ledges 86 and 88, respectively, halfway up the sides and on the inside faces thereof so as to divide the inside of the U-shaped section into upper and lower portions, with the upper inside portions of sides 90 and 92 having saw teeth 94 as shown in the figure.

A generally U-shaped vinyl track 95 having corresponding saw teeth 94A on the outer surfaces thereof is inserted in the upper portion of the U-shaped section so as to rest on ledges 86 and 88, with the saw teeth of the track and section being engaged for rendering the track substantially immobile. Track 95 has shoulders 96 and 97 which rest on the upper ends of sides 90 and 92. The end of a glass pane 104 is inserted in track 95, and which track snugly hugs the glass pane. The

upper, lower and side members of the glass insert are secured each to the other by keys (not shown) such as the key 31 in FIG. 4, and which keys are inserted in the lower portion of the U-shaped section, for forming a rigid glass insert. The glass insert is assembled in frame 14 by engaging outer faces 81 and 83 of sides 90 and 92 thereof in the frame member track 19 formed by side 21 and weatherstripping 27 to provide a seal as heretofore referred to.

Side 92 has at its upper end thereof a member 100 extending transversely and substantially normal thereto. The end of member 100 has a lip 101 extending upward and substantially parallel to side 92 and glass pane 104 so as to form with pane 104 a channel 105. Channel 105 receives and retains grill 81 as described with reference to FIG. 5. It is to be noted that the arrangement is such that grill 81 is assembled so as to be on the outside of screen 80 and on the inside of glass 104 so as to provide the intended decorative feature as shown in FIG. 8.

In summation, the novel features of the storm door assembly of the present invention include the one-piece panels 4A and 4B and the core 8 sandwiched therebetween and supporting the panels without metal contact for improving the thermal and sound insulating characteristics of the door.

Hinges 6 are preassembled to structure 2 through rivets 62. In this manner hinges 6 are prelocated on structure 2 to facilitate installation, and loss and mutilation of the hinges is prevented.

Frame 14 is designed to rigidly retain panels 4A and 4B and core 8 sandwiched therebetween for forming opening 14 and for retaining the screen and glass inserts to prevent rattling and looseness. The inserts which feature spline 82 and channel 95 for retaining screen 82 and glass 104, respectively, additionally retain grill 81 to enhance the decorative features of the door.

Although several embodiments of the invention have been illustrated and described in detail, it is to be expressly understood that the invention is not limited thereto. Various changes may also be made in the design and arrangement of the parts without departing from the scope and spirit of the invention as the same will now be understood by those skilled in the art.

What we claim is:

1. A door assembly, comprising:

- a pair of panels;
- a core sandwiched between and supporting the panels, said panels and core having portions which cooperate to define a rectangular opening in the door;
- a frame in the opening having upper, lower and side members, said upper and lower members having a generally H-shaped section with a pair of upper legs, a pair of lower legs and a crossbar, and said side members having a section with a pair of upper legs, a lower leg and a crossbar;
- the upper legs of the H and side member sections shouldering toward the center of said sections and providing shoulders having laterally extending channels which retain the portions of the panels defining the opening;
- the shoulders of the upper legs and the crossbars of the H and side member sections cooperating to provide a channel which retains a key, said key securing a frame member to an adjacent frame member;
- a rectangular insert;
- one of said lower legs of the H-section and the lower leg of the side member section having a laterally extending channel retaining a weather sealing strip, said strip and the other lower leg of the H-section cooperating to provide a track which retains the insert;
- the insert including upper, lower and side members, each of which has a generally U-shaped section with substantially parallel sides, and each of which sides has a ledge on the inner face thereof dividing the U-section into upper and lower portions;
- the inner faces of the sides having a plurality of saw teeth on the upper portion thereof;

a generally U-shaped channel with substantially parallel sides is positioned in the upper portion of the U-section, the bottom of said channel resting on the ledges and the outer faces of said channel having a corresponding plurality of saw teeth engaging the saw teeth in the U-shaped section and securing the channel therein, said channel having outwardly extending lips on the ends of both sides thereof which rest on the ends of the sides of the U-shaped section;

a glass pane having upper, lower and side edges, said edges positioned in the U-shaped channel of the corresponding insert member retaining the glass pane therein;

the lower portion of the U-section providing a channel which retains a key, said key securing an insert member to an adjacent insert member; and

the sides of the U-shaped section being positioned in the track for retaining the insert in the frame.

2. A door as described by claim 1, including:

- a decorative grill;
- one of the sides of the U-section having an arm extending normal thereto; and
- said arm having a longitudinally extending end for providing with the glass pane a channel which retains the grill.

3. A door assembly, comprising:

- a pair of panels;
- a core sandwiched between and supporting the panels, said panels and core having portions which cooperate to define a rectangular opening in the door;
- a frame in the opening having upper, lower and side members, said upper and lower members having a generally H-shaped section with a pair of upper legs, a pair of lower legs and a crossbar, and said side members having a section with a pair of upper legs, a lower leg and a crossbar;
- the upper legs of the H and side member sections shouldering toward the center of said sections and providing shoulders having laterally extending channels which retain the portions of the panels defining the opening;
- the shoulders of the upper legs and the crossbars of the H and side member sections cooperating to provide a channel which retains a key, said key securing a frame member to an adjacent frame member;
- a rectangular insert;
- one of said lower legs of the H-section and the lower leg of the side member section having a laterally extending channel retaining a weather sealing strip, said strip and the other lower leg of the H-section cooperating to provide a track which retains the insert;
- the insert including upper, lower and side members each of which has a section including a generally O-shaped portion with substantially parallel sides and a substantially parallel top and bottom;
- one of said sides being elongated to provide a base for a generally T-shaped portion having a crossbar extending substantially parallel to the top of the O-shaped portion, and one side of said crossbar cooperating with said top to form a laterally extending generally C-shaped channel;
- a screen sheet having upper, lower and side edges, said edges positioned in the C-shaped channel of the corresponding insert member;
- rod shaped splines positioned over the screen edges and retaining the edges the edges in the channels;
- the center part of the O-shaped portion providing a channel which retains a key, said key securing an insert member to an adjacent insert member;
- the sides of the O-shaped portions of the members being positioned in the track for retaining the insert in the frame;
- a decorative grill; and
- the crossbar of the T-shaped portion having longitudinally extending ends providing a channel which retains the grill.