

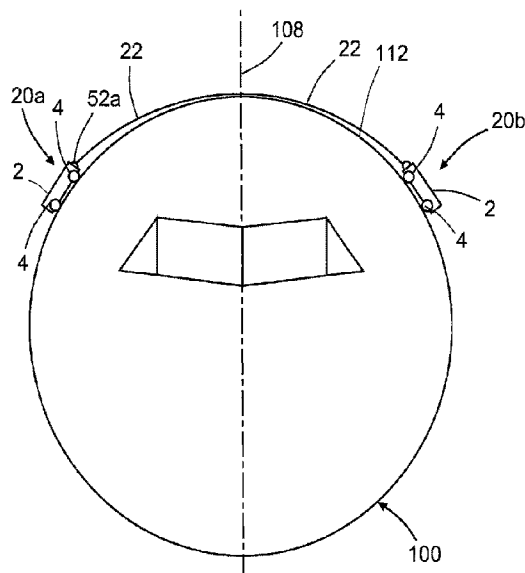

(22) Date de dépôt/Filing Date: 2019/05/02
(41) Mise à la disp. pub./Open to Public Insp.: 2020/01/25
(45) Date de délivrance/Issue Date: 2023/03/21
(30) Priorité/Priority: 2018/07/25 (US16/044651)

(51) Cl.Int./Int.Cl. *B25J 5/00* (2006.01),
B60D 99/00 (2009.01)
(72) Inventeurs/Inventors:
GEORGESON, GARY E., US;
TROY, JAMES J., US;
LEA, SCOTT W., US
(73) Propriétaire/Owner:
THE BOEING COMPANY, US
(74) Agent: SMART & BIGGAR LP

(54) Titre : COMPENSATION GRAVITATIONNELLE POUR VEHICULES ROBOTIQUES AUTOMOTEURS RAMPANT SUR DES SURFACES INEGALES
(54) Title: GRAVITY COMPENSATION FOR SELF-PROPELLED ROBOTIC VEHICLES CRAWLING ON NON-LEVEL SURFACES



(57) **Abrégé/Abstract:**

Apparatus and methods for providing gravity compensation to a cable-suspended, vacuum-adhered, tool-equipped crawler vehicle traveling along and following the contour of a non-level surface during the execution of an automated maintenance operation. One technical feature shared by multiple embodiments of the gravity-compensating systems is that a cable spool is operated to wind a portion of the cable from which the vacuum-adhered crawler vehicle is suspended to generate a tensile force that counteracts a gravitational force being exerted on the crawler vehicle during movement. Rotation of the cable spool may be driven by a motor or by a tensioning spring.

ABSTRACT

Apparatus and methods for providing gravity compensation to a cable-suspended, vacuum-adhered, tool-equipped crawler vehicle traveling along and following the contour of a non-level surface during the execution of an automated maintenance operation. One technical feature shared by multiple
5 embodiments of the gravity-compensating systems is that a cable spool is operated to wind a portion of the cable from which the vacuum-adhered crawler vehicle is suspended to generate a tensile force that counteracts a gravitational force being exerted on the crawler vehicle during movement. Rotation of the cable spool may be driven by a motor or by a tensioning spring.

GRAVITY COMPENSATION FOR SELF-PROPELLED ROBOTIC VEHICLES CRAWLING ON NON-LEVEL SURFACES

BACKGROUND

This disclosure generally relates to automated systems for carrying maintenance tools across surfaces, such maintenance tools including (but not limited to) sensors used in non-destructive inspection (NDI). In particular, this disclosure relates to self-propelled surface-crawling robotic vehicles (hereinafter “crawler vehicles”) that are capable of moving on inclined or vertical surfaces (hereinafter “non-level surfaces”) of large structures such as aircraft fuselages, storage tanks and wind turbine blades.

It is known to manually inspect and clean large structures such as aircraft fuselages, storage tanks and wind turbine blades by hoisting a person to a position adjacent to the structure. However, manual inspection and cleaning can be time-consuming and difficult operations. To mitigate the drawbacks of manual inspection and cleaning, various solutions involving automated apparatus (e.g., crawler vehicles) configured to travel along non-level surfaces of a large structure have been proposed. For example, solutions have been proposed in which a tool-equipped crawling vehicle is attached to the end of a tether cable while the crawler vehicle is in contact with and “adhered” to a non-level surface by suction or vacuum forces. The vacuum adherence functionality is provided by one or more vacuum adherence devices that enable the crawler vehicle to adhere to but still translate and/or rotate over the non-level surface.

In applications where crawler vehicles need to operate on non-level surfaces, such as moving around the circumference of an airplane fuselage, the magnitude of the vacuum adherence forces needed to sustain the desired position and navigate may be difficult to attain. And even in those cases where sufficient vacuum adherence force is available, the locomotion power required for moving the crawler vehicle in vertical or nearly vertical directions can be undesirably high.

Increasing the adherence force or locomotion power adds complexity and cost to these robotic systems, and can limit their cost-effective use cases.

5 The existing solutions of higher suction flow (vacuum adherence) or higher-energy electrostatics (attraction) require increased complexity and system costs, as well as performance risks, including surface damage due to high adherence loads. Current solutions do not address the slippage problem associated with dirt, grease, water, or other debris on the surface of the structure on which the robot is crawling. Current tethers can keep crawler vehicles from falling to the ground, but do not help maintain vacuum adherence or electrostatic attraction to the surface in the face of gravity. Current solutions do not help crawler vehicles to maintain movement along a horizontal line without slippage in the direction of gravity. They also do not enable ascending vertical motion without higher adherence or power requirements.

10

SUMMARY

15 The subject matter disclosed in some detail below is directed to apparatus and methods for providing gravity compensation to a cable-suspended, vacuum-adhered, tool-equipped crawler vehicle traveling along and following the contour of a non-level surface during the execution of an automated maintenance operation (e.g., non-destructive inspection or other maintenance operation). One technical feature shared by multiple embodiments of the gravity-compensating systems disclosed herein is that a cable spool (not onboard the tool-equipped crawler vehicle) is rotated to wind a portion of the cable from which the vacuum-adhered crawler vehicle is suspended to generate a tensile force that counteracts a gravitational force being exerted on the crawler vehicle during movement. Rotation of the cable spool may be driven by a motor or by a tensioning spring.

20

25

Several embodiments are disclosed in some detail below, which embodiments include configurations of components that vary in dependence on the

geometry of the structure undergoing maintenance. For examples, an aircraft fuselage may have sections with cylindrical external surfaces and storage tanks may have a spherical external surface, a cylindrical side external surface with a dome-shaped top external surface, or a cylindrical side external surface with a flat top external surface.

5
10
15
The vacuum adherence functionality referred to above is provided by one or more vacuum adherence devices that enable each crawler vehicle to adhere to but still translate and/or rotate over the surface to which the crawler vehicle is adhered. Each vacuum adherence device is designed to “float” when the vacuum adherence device is partially evacuated. As used herein, “float” means that the suction components are compliant (spring loaded) with low-friction pads that slide across the surface. The system is rotationally compliant as well as compliant along the Z-axis. The resulting total suction force is strong enough to adhere the crawler vehicle to the structure, but not so strong as to inhibit lateral displacement or rotation. Thus, the term “adherence” as used herein means a floating adherence that allows the crawler vehicles to move over a surface. In contrast, the term “attachment” as used herein includes non-floating adherence (a.k.a. adhesion) and does not include floating adherence.

20
Although various embodiments of apparatus and methods for providing gravity compensation for cable-suspended, vacuum-adhered, tool-equipped crawler vehicles on non-level surfaces are described in some detail later herein, one or more of those embodiments may be characterized by one or more of the following aspects.

25
One aspect of the subject matter disclosed in detail below is a method for compensating for gravity during movement of a crawler vehicle on a surface of a body (e.g., an aircraft fuselage or a storage tank). The method comprises: (a) attaching one end of a first cable to a first crawler vehicle; (b) attaching another end of the first cable to a first spool of a second crawler vehicle;

(c) placing the first crawler vehicle at a first position in contact with a first surface area on the surface of the body, wherein the first surface area is non-level; (d) placing the second crawler vehicle at a second position in contact with a second surface area on the surface of the body; (e) adhering the first crawler vehicle to the surface of the body using suction; (f) while the first crawler vehicle is adhered to the surface, moving the first crawler vehicle along a first path that extends from the first position to a third position in contact with a third surface area on the surface of the body; (g) tensioning the first cable to exert a tensile force on the first crawler vehicle having a vector component in opposition to a force of gravity tending to urge the first crawler vehicle to a lower elevation during step (f); and (h) operating a maintenance tool of the first crawler vehicle to perform a maintenance operation on the surface at a point along the first path, wherein step (g) comprises winding a portion of the first cable on the first spool.

In accordance with one embodiment of the method described in the immediately preceding paragraph, the method further comprises attaching the second crawler vehicle to the surface at the second position by producing an attachment force having a magnitude sufficient to prevent detachment of the second crawler vehicle even when supporting an entire weight of the first crawler vehicle. The attachment force may be produced, for examples, by one of the following forces: suction, electrostatic adhesion or magnetic attraction.

In accordance with another embodiment, the method further comprises: moving the second crawler vehicle along a second path while the first crawler vehicle is moving along the first path; and operating a maintenance tool of the second crawler vehicle to perform a maintenance operation on the surface at a point along the second path.

In accordance with a further embodiment, the method further comprises: (i) attaching one end of a second cable to a third crawler vehicle; (j) attaching another end of the second cable to a second spool of the second crawler

vehicle; (k) placing the third crawler vehicle at a fourth position in contact with a fourth surface area on the surface of the body, wherein the fourth surface area is non-level; (l) adhering the third crawler vehicle to the surface of the body using suction; (m) while the third crawler vehicle is adhered to the surface, moving the
5 third crawler vehicle along a second path that extends from the fourth position to a fifth position in contact with a fifth surface area on the surface of the body; and (n) tensioning the second cable to exert a tensile force on the third crawler vehicle having a vector component in opposition to a force of gravity tending to urge the third crawler vehicle to a lower elevation during step (m).

10 In accordance with yet another embodiment, the method further comprises: attaching one end of a second cable to a second spool of a ground vehicle; attaching another end of the second cable to the second crawler vehicle; and placing the ground vehicle in contact with the ground on the other side of the vertical mid-plane, wherein step (g) comprises winding a portion of the second
15 cable on the second spool.

Another aspect of the subject matter disclosed in detail below is a method for performing a maintenance operation on a body having a top surface and a non-level side surface that extends downward to elevations lower than a lowest elevation of the top surface. The method comprises: (a) attaching one end
20 of a cable to a crawler vehicle that is carrying a maintenance tool; (b) attaching another end of the cable to a spool of an anchor device; (c) placing the anchor device in contact with the top surface of the body; (d) attaching the anchor device to the top surface with an attachment force having a magnitude sufficient to prevent detachment of the anchor device by producing an attachment force having
25 a magnitude sufficient to prevent detachment of the crawler vehicle even when supporting an entire weight of the crawler vehicle; (e) placing the crawler vehicle in contact with the non-level side surface of the body; (f) adhering the crawler vehicle to the non-level side surface using suction; (g) moving the crawler vehicle along a path while the crawler vehicle is adhered to the non-level side surface; (h)

tensioning the cable to exert a tensile force on the crawler vehicle having a vector component in opposition to a force of gravity tending to urge the crawler vehicle to a lower elevation during step (g); and (i) operating the maintenance tool to perform a maintenance operation on the non-level side surface at a point along the path.

5 In accordance with some embodiments of a method for performing a maintenance operation on a body having a top surface with a circular outer periphery, the method described in the immediately preceding paragraph further comprises: rotatably coupling a spool to a distal end of a rotatable arm; placing a proximal end of the rotatable arm on the top surface of the body so that a center of rotation of the rotatable arm is aligned with a center of the circular outer periphery; and rotating the rotatable arm, wherein the rotatable arm has a length that enables a portion of the spool to extend beyond the circular outer periphery of the top surface during rotation of the rotatable arm about the center of rotation.

15 A further aspect of the subject matter disclosed in detail below is an apparatus comprising a first and second crawler vehicles and a cable having one end connected to the first crawler vehicle and another end connected to the second crawler vehicle, wherein: each of the first and second crawler vehicles comprises: a frame; at least one vacuum adherence device attached to or integrated with the frame; a set of wheels rotatably coupled to the frame; a drive motor operatively coupled to drive rotation of at least one of the wheels; and a computer system configured to control operation of the drive motor, the first crawler vehicle further comprises a maintenance tool configured for performing a maintenance operation; and the second crawler vehicle further comprises a cable spool to which the other end of the cable is attached and a spool motor.

25 Yet another aspect of the subject matter disclosed in detail below is an apparatus comprising an anchor device, a crawler vehicle and a cable having one end connected to the anchor device and another end connected to the crawler vehicle, wherein the anchor device comprises: an anchor base; at least one

attachment device coupled to the anchor base for attaching the anchor device to a surface; a cable spool to which the one end of the cable is attached; a spool motor operatively coupled to drive rotation of the cable spool; and a first computer system configured to control operation of the spool motor, and wherein the crawler vehicle comprises: a frame; at least one vacuum adherence device attached to or integrated with the frame; a set of wheels rotatably coupled to the frame; a drive motor operatively coupled to drive rotation of at least one wheel of the set of wheels; a maintenance tool coupled to the frame and configured for performing a maintenance operation; and a second computer system configured to control operation of the drive motor and the maintenance tool.

In accordance with some embodiments of the apparatus described in the immediately preceding paragraph, the apparatus further comprises: a turret which is rotatably coupled to the anchor base; and an arm having a proximal end connected to or integrally formed with the turret and a distal end to which the cable spool is rotatably coupled.

Other aspects of an apparatus and methods for providing gravity compensation for cable-suspended, vacuum-adhered, tool-equipped crawler vehicles moving on non-level surfaces are disclosed below.

BRIEF DESCRIPTION OF THE DRAWINGS

The features, functions and advantages discussed in the preceding section may be achieved independently in various embodiments or may be combined in yet other embodiments. Various embodiments will be hereinafter described with reference to drawings for the purpose of illustrating the above-
5 described and other aspects. None of the diagrams briefly described in this section are drawn to scale.

FIGS. 1A and 1B are diagrams representing front end views of an aircraft fuselage at two different instants in time during an automated maintenance procedure performed using a gravity-compensating system that includes a pair of
10 cable-suspended, vacuum-adhered crawler vehicles in accordance with a first embodiment. The length of paid-out cable shown in FIG. 1B is greater than the length of paid-out cable shown in FIG. 1A.

FIGS. 2A and 2B are diagrams representing views of respective storage tanks undergoing automated maintenance using a pair of cable-
15 suspended, vacuum-adhered crawler vehicles.

FIG. 3A is a diagram representing a top view of a cable-suspended, vacuum-adhered, tool-equipped crawler vehicle in accordance with one embodiment.

FIGS. 3B and 3C are side and end views respectively of the cable-
20 suspended, vacuum-adhered, tool-equipped crawler vehicle depicted in FIG. 3A.

FIG. 4 is a diagram representing a top view of a cable-suspended, vacuum-adhered, spool-equipped crawler vehicle in accordance with one embodiment.

FIG. 5 is a diagram representing a three-dimensional view of parts of a
25 holonomic-motion crawler vehicle having two suction zones in accordance with one

embodiment. The electrical connections for supplying signals for controlling operation of the depicted components and other components are not shown.

FIG. 6 is a diagram showing a bottom view of a Mecanum-wheeled crawler vehicle having dual suction zones.

5 FIG. 7A is a diagram representing a view of a holonomic-motion crawler vehicle that has front and back sets of four vacuum adherence devices in accordance with one embodiment.

FIG. 7B is a diagram representing a bottom view of the holonomic-motion crawler vehicle depicted in FIG. 7A,

10 FIG. 8A is a diagram representing a cross-sectional view of a vacuum adherence device in accordance with one implementation.

FIG. 8B is a diagram representing a cross-sectional view of the vacuum adherence device depicted in FIG. 8A adhered to a non-planar blade surface. The air gap between the vacuum adherence device and the non-planar surface has been exaggerated for the purpose of illustration.

15 FIGS. 9 and 10 are diagrams representing front views of portions of a crawler vehicle that has left and right vacuum adherence devices and further showing the forces exerted by a horizontal surface (see FIG. 9) and an inclined surface (see FIG. 10) on the Mecanum wheels of the crawler vehicle when the Mecanum wheels 4a and 4c on one side are at one elevation and the Mecanum wheels 4b and 4d on the other side are at another elevation.

20 FIG. 11A is a diagram representing a top view of a Mecanum-wheeled frame of a crawler vehicle having a fixed NDI scan head attached to one end thereof.

FIG. 11B is a diagram representing a top view of a Mecanum-wheeled frame of a crawler vehicle having a reciprocating NDI scan head mounted to one end thereof.

5 FIGS. 12A-12D are diagrams representing top views of a holonomic-motion crawler vehicle in accordance with an alternative embodiment which has a passive connection that pivots about the center of the vertical axis of the vehicle, with an arm that is shaped to allow the cable force to project through the center of mass of the vehicle (but not interfere with the crawler or the sensor payload).

10 FIG. 13 is a diagram representing a side view of a pair of holonomic-motion crawler vehicles having a passive connection of the type depicted in FIGS. 12A-12D.

FIG. 14A is a block diagram identifying some components of a holonomic-motion crawler vehicle having both a cable spool and a carriage for a maintenance tool in accordance with another embodiment.

15 FIG. 14B is a block diagram identifying some components of a gravity-compensating system in which two cable-connected crawler vehicles vacuum adhered to a body (e.g., an aircraft fuselage) communicate wirelessly with a ground-based control computer.

20 FIG. 15 is a diagram representing a front end view of an aircraft fuselage at an instant in time during an automated maintenance procedure performed using a gravity-compensating system that includes a first vacuum-adhered crawler vehicle suspended by a primary umbilical cable from a boom and second and third vacuum-adhered, tool-equipped crawler vehicles connected to the first vacuum-adhered crawler vehicle by respective secondary cables in
25 accordance with a second embodiment.

FIG. 16 is a diagram representing a front end view of an aircraft fuselage at an instant in time during an automated maintenance procedure performed using a gravity-compensating system that includes a cart equipped with a wireless communication system and a pair of vacuum-adhered, tool-equipped crawler vehicles connected to the cart by respective cables in accordance with a third embodiment.

FIG. 17 is a block diagram identifying some components of a system for performing an ultrasonic inspection on a surface of a body in accordance with one proposed computer architecture.

FIG. 18A is a block diagram identifying some components of a gravity-compensating system that includes a cart having a spring-driven cable spool that generates a tensile force to counteract a gravitational force being exerted on a moving cable-suspended crawler vehicle.

FIG. 18B is a block diagram identifying some components of a gravity-compensating system that includes a cart having a motor-driven cable spool that generates a tensile force to counteract a gravitational force being exerted on a moving cable-suspended crawler vehicle.

FIGS. 19A and 19B are diagrams representing front end views of an aircraft fuselage at two different instants in time during an automated maintenance procedure performed using a gravity-compensating system that includes an anchor device and a cable-suspended, vacuum-adhered, tool-equipped crawler vehicle in accordance with a fourth embodiment. The length of paid-out cable shown in FIG. 19B is greater than the length of paid-out cable shown in FIG. 19A.

FIGS. 20A and 20B are diagrams representing front end views of an aircraft fuselage at two different instants in time during an automated maintenance procedure performed using a gravity-compensating system that includes a vacuum-adhered, tool-equipped crawler vehicle connected via a cable to a surface-

attached crawler vehicle in accordance with a fifth embodiment. The length of paid-out cable shown in FIG. 20B is greater than the length of paid-out cable shown in FIG. 20A.

5 FIG. 21 is a diagram representing a front end view of an aircraft fuselage at an instant in time during an automated maintenance procedure performed using a gravity-compensating system that includes a spool-equipped ground vehicle, a vacuum-adhered spool-equipped crawler vehicle and a vacuum-adhered tool-equipped crawler vehicle connected by cables in accordance with a sixth embodiment.

10 FIG. 22 is a diagram representing a front end view of an aircraft fuselage at an instant in time during an automated maintenance procedure performed using a gravity-compensating system that includes a spool-equipped ground vehicle and a tool-equipped crawler vehicle connected to the ground vehicle by a cable, and a cable-lifting crawler vehicle that supports an intermediate
15 section of the cable in accordance with a seventh embodiment.

FIG. 23 is a diagram representing a view of a storage tank at an instant in time during an automated maintenance procedure performed using a gravity-compensating system that includes a spool-equipped lifting carriage that rides on a circular track placed on a top surface of the storage tank and a cable-suspended tool-equipped crawler vehicle vacuum adhered to a side surface of the
20 storage tank in accordance with an eighth embodiment.

FIG. 24 is a diagram representing a view of a storage tank at an instant in time during an automated maintenance procedure performed using a gravity-compensating system that includes a spool-equipped crawler vehicle disposed on a top surface of the storage tank and a cable-suspended tool-equipped crawler vehicle vacuum adhered to a side surface of the storage tank in
25 accordance with a ninth embodiment.

FIG. 25 is a diagram representing a view of a storage tank at an instant in time during an automated maintenance procedure performed using a gravity-compensating system that includes a passive turret-mounted spool-equipped arm rotatably coupled to a top surface of the storage tank and a cable-suspended tool-equipped crawler vehicle vacuum adhered to a side surface of the storage tank in accordance with a tenth embodiment.

FIG. 26 is a diagram representing a view of a storage tank at an instant in time during an automated maintenance procedure performed using a gravity-compensating system that includes a motor-driven turret-mounted spool-equipped arm rotatably coupled to a top surface of the storage tank and a cable-suspended tool-equipped crawler vehicle vacuum adhered to a side surface of the storage tank in accordance with an eleventh embodiment.

FIG. 27 is a block diagram identifying some of the components of the gravity-compensating system depicted in FIG. 26.

Reference will hereinafter be made to the drawings in which similar elements in different drawings bear the same reference numerals.

DETAILED DESCRIPTION

The improvements disclosed herein may be incorporated in or utilized with an automated apparatus for performing maintenance functions on large structures such as aircraft fuselages and storage tanks. As used herein, the term "maintenance" includes, but is not limited to, operations such as non-destructive inspection, drilling, scarfing, grinding (e.g., to remove bonded or bolted components), fastening, applique application, ply mapping, cleaning, marking and painting.

For the purpose of illustration, apparatus and methods for performing automated maintenance operations on an aircraft fuselage or on a storage tank will now be described in detail. However, not all features of an actual implementation are described in this specification. A person skilled in the art will appreciate that in the development of any such embodiment, numerous implementation-specific decisions must be made to achieve the developer's specific goals, such as compliance with system-related and business-related constraints, which will vary from one implementation to another. Moreover, it will be appreciated that such a development effort might be complex and time-consuming, but would nevertheless be a routine undertaking for those of ordinary skill in the art having the benefit of this disclosure.

A maintenance tool is a device that performs a maintenance operation, such as non-destructive inspection or cleaning of an external surface of a body at multiple positions along a scan path. In accordance with some embodiments disclosed hereinafter, the automated apparatus comprises one or more maintenance tool-equipped crawler vehicles suspended from cables. In the case where the maintenance operation is non-destructive inspection, a cable-suspended crawler vehicle may scan an area on a surface of a body. The cable length may be adjusted to change the elevation of the crawler vehicle to ensure full coverage of the surface during scanning.

In accordance with some embodiments, the crawler vehicles are configured to be capable of holonomic motion. A holonomic-motion system is one that is not subject to motion constraints. As used in this disclosure, a vehicle is considered to be holonomic if the controllable degrees of freedom are equal to the total degrees of freedom. This type of vehicle can translate in any direction while simultaneously rotating. This is different than most types of ground vehicles, such as car-like vehicles, tracked vehicles, or wheeled differential-steer (skid-steer) vehicles, which cannot translate in any direction while rotating at the same time.

The maintenance tool of the crawler vehicle may be selected from a group of interchangeable maintenance tools, including NDI sensors of different types (e.g., an ultrasonic transducer array, an infrared thermography unit, a video camera, an optical three-dimensional coordinate measuring machine or a laser line scanner), a cleaning unit, and so forth. In accordance with one proposed implementation, the automated apparatus comprises a pair of crawler vehicles each capable of supporting any one of a plurality of maintenance tools for performing a set of maintenance functions on an aircraft fuselage or a storage tank. As a whole, the automated apparatus disclosed herein reduces maintenance time, labor hours and human errors and increases safety.

When performing automated maintenance operations on structures or bodies that have large surface areas (such as an aircraft fuselage or a storage tank), it is common practice to use a tool-equipped crawler vehicle that is vacuum adhered and then moved relative to the surface being maintained. In cases wherein the maintenance operation involves covering an entire surface (e.g., when scanning a surface during a non-destructive inspection), the maintenance tool may, for example, scan adjacent vertical or horizontal strip-shaped zones in successive passes. In applications where tool-equipped crawler vehicles need to operate on steep or vertical surfaces, such as moving around the circumference of an airplane fuselage, the attachment forces needed to sustain the desired position and navigate on the surface can be very high. And even in those cases where sufficient attraction force is available, the locomotion power required for moving the crawler vehicle in vertical or nearly vertical directions can be very high.

To address these issues, this disclosure proposes in some situations (like the fuselage example) to have two or more crawler vehicles tethered (by means of a cable) together to assist each other during scanning operations by providing lift assistance forces with a significant vertical component to counteract gravity. In one example, the crawler vehicles may be located on and vacuum adhered to opposite sides of a target object and equipped with means for providing

balanced forces to each crawler vehicle for the purpose of lift assistance as well as to keep each other from falling should one crawler vehicle lose surface adhesion.

In accordance with one embodiment, two crawler vehicles are disposed on opposite sides of an aircraft fuselage and connected by a tether cable. One of the crawler vehicles is equipped with a winch while the other crawler vehicle is equipped with a tool (e.g., an NDI sensor unit) for performing a maintenance operation. During the maintenance operation, the cable-suspended crawler vehicles are subject to gravitational forces that tend to urge the crawler vehicles to lower elevations. The length and tension of the tether cable is managed by the winch which includes a cable spool that is rotated to produce tension in the cable. The tension in the cable in turn exerts a tensile force on the tool-equipped crawler vehicle, which tensile force has a vector component in opposition to the force of gravity that is tending to urge the tool-equipped crawler vehicle to a lower elevation.

In addition to aircraft fuselages, large and small holding tanks, oil and gas tanks, large pipelines, and other large structures could be maintained (e.g., inspected) using active anti-gravity tethering of two or more crawling vehicles.

FIGS. 1A and 1B are diagrams representing front end views of an aircraft fuselage **100** at two different instants in time during an automated maintenance procedure performed using a gravity-compensating system in accordance with a first embodiment that includes a pair of cable-suspended, vacuum-adhered crawler vehicles **20a** and **20b**. Each of the crawler vehicles **20a** and **20b** include a frame **2** and four wheels **4** rotatably coupled to the frame **2**. Although not shown in FIGS. 1A and 1B, the crawler vehicle **20b** carries a maintenance tool. Optionally, the crawler vehicle **20a**, which includes a cable spool **52a**, may also carry a maintenance tool. Each of the crawler vehicles **20a** and **20b** includes a multiplicity of motors, a multiplicity of motor controllers and may include a computer (not shown in FIGS. 1A and 1B) configured to enable the crawler

vehicle to move autonomously over the external surface **112** of the aircraft fuselage **100** during a maintenance operation. However, as seen in FIGS. **1A** and **1B**, the crawler vehicles **20a** and **20b** are tethered to each other by means of a cable **22**. (Note that in FIGS. **1A** and **1B** and some other figures, cable **22** is drawn in an arc shape even though it is sometimes separated from the surface, instead of a straight line tangent to the surface; this was done to make the cable **22** easier to see in the figures and simpler to draw.) One end of the cable **22** is attached to the cable spool **52a** of the crawler vehicle **20a** while the other end of the cable **22** is attached to the frame **2** (e.g., by means of a hook) of the crawler vehicle **20b**. Thus at any given moment in time, the ability of one crawler vehicle to move in a cable tensioning direction aligned with the cable **22** at the point of cable attachment is constrained. When the cable **22** is taut, movement of the crawler vehicle **20b** in a cable tensioning direction is enabled by pay-out of an additional length of cable **22** by the cable spool **52a** of the crawler vehicle **20a** or by simultaneous movement of the connected vehicle.

FIG. **1A** depicts the aircraft fuselage **100** at a first instant in time when the crawler vehicles **20a** and **20b** are symmetrically disposed on opposite sides of a vertical plane of symmetry **108** (indicated by a dashed line in FIG. **1A**) at a first elevation. In this situation, the length of paid-out cable shown in FIG. **1A** is equal to a first length. While at the first elevation on opposite sides of a symmetrical aircraft fuselage **100**, the wheels **4** of the crawler vehicles **20a** and **20b** will be in contact with respective non-level surface areas having angles of inclination which are equal in magnitude but opposite in sign (or if the surface areas are convex curved, the lines connecting the endpoints of respective arc-shaped profiles will have angles of inclination which are equal in magnitude but opposite in sign). In the symmetrical state depicted in FIG. **1A**, the gravitational forces respectively exerted on the crawler vehicles **20a** and **20b** (assuming equal masses) will be equal and balanced.

During a maintenance operation (e.g., during non-destructive inspection), the crawler vehicles **20a** and **20b** may be moved concurrently in opposite directions in a vertical plane perpendicular to the vertical plane of symmetry **108** (and perpendicular to a longitudinal axis of the aircraft fuselage **100**) to change their elevation. For example, FIG. **1B** depicts the aircraft fuselage **100** at a second instant in time (subsequent to the first instant in time) when the crawler vehicles **20a** and **20b** are symmetrically disposed on opposite sides of the vertical plane of symmetry **108** at a second elevation which is lower than the first elevation. To position the crawler vehicles **20a** and **20b** at these positions, an additional length of cable **22** is paid out from the cable spool **52a**, which allows the circumferential distance separating the crawler vehicles **20a** and **20b** to increase as seen in FIG. **1B**. In other words, the length of paid-out cable **22** shown in FIG. **1B** is greater than the length of paid-out cable shown in FIG. **1A**.

In either of the situations depicted in FIG. **1A** and **1B**, the crawler vehicles **20a** and **20b** may be concurrently moved horizontally along the external surface **112** during a scanning operation. For example, if crawler vehicle **20b** were carrying an ultrasonic transducer array, then a stripe-shaped area of the external surface **112** may be ultrasonically inspected along a first scan path having a scan path length, which first scan path is generally horizontal.

For example, in a case where the crawler vehicle **20b** is vacuum adhered to an inclined surface without connection to a cable **22** and is capable of holonomic motion, the amount of suction being produced must be adjusted to produce wheel frictional forces sufficient to counteract the gravitational force component parallel to the inclined surface. The greater the magnitude of the suction forces generated, the greater the amount of electric power consumed. In addition, the fan motors producing the suction forces must be designed to produce higher fan speeds, thereby increasing the cost and weight of the crawler vehicle.

This disclosure proposes to reduce the amount of electrical power consumed and the cost and weight of the crawler vehicle by providing gravity-compensating means in the form of a cable **22**. As will be explained in more detail below, the presence of a cable-provided tensile force on the crawler vehicle allows the suction forces to be reduced, thereby enabling the design of a crawler vehicle that is lighter in weight, lower in cost and uses less electrical power to maintain a true horizontal scan path.

Still referring to FIGS. **1A** and **1B**, the assistant tensile force applied by the cable **22** is generated by producing a torque on the cable spool **52a** to which the cable **22** is connected. The crawler vehicle **20a** on which the cable spool **52a** is mounted may be operated to move concurrently along a second scan path that mirrors the first scan path of the crawler vehicle **20b**. As the crawler vehicles **20a** and **20b** move horizontally in tandem, the cable spool **52a** on the crawler vehicle **20a** may be torqued to change the tension in cable **22**, thereby adjusting the tensile force being exerted on the crawler vehicle **20b** to counteract the gravitational force being exerted during scanning.

In an alternative scanning scenario, the crawler vehicle **20b** may be designed for vertical scanning an aircraft fuselage **100**. For example, as the crawler vehicle **20b** moves upward from the lower elevation depicted in FIG. **1B** to the higher elevation depicted in FIG. **1A**, an ultrasonic transducer array mounted to the crawler vehicle **20b** may be activated to acquire ultrasonic inspection data from a vertical stripe-shaped surface area on the external surface **112** of the aircraft fuselage **100**. During this vertical scan, the wheel frictional forces needed to overcome the force of gravity may be reduced by tensioning the cable **22** as previously described to provide gravity-compensating assistance.

In accordance with a further alternative embodiment, the spool-equipped crawler vehicle **20a** may also be equipped with a maintenance tool. In this case maintenance operations may be performed concurrently on both sides of

the aircraft fuselage **100**. During horizontal motion in tandem, the length of the cable **22** may be constant (to the extent that the external surface being scanned is circular cylindrical) while the tension in the cable **22** is adjusted to provide anti-gravity assistance to both crawler vehicles. During upward vertical motion in tandem, the length of the cable **22** decreases as the crawler vehicles **20a** and **20b** move upward and the tension in the cable **22** may be repeatedly adjusted to provide anti-gravity assistance as both crawler vehicles **20a** and **20b** are lifted.

The concept of scanning an external surface of a large body using a pair of tethered crawler vehicles is not limited in its application to aircraft fuselages. FIG. **2A** is a diagram representing a view of a spherical storage tank **102** undergoing automated maintenance using a pair of vacuum-adhered crawler vehicles **20a** and **20b** (equipped respectively with a cable spool **52** and a maintenance tool as previously described with reference to FIGS. **1A** and **1B**) connected to opposite ends of a cable **22**. The crawler vehicles **20a** and **20b** are vacuum adhered to the spherical surface **113** at opposed positions lying in a hypothetical vertical plane that bisects the sphere. A pivoting guide **15** includes a base attached to the crown of the spherical storage tank **102** and a turret that rotates relative to the attached base. The base of the pivoting guide **15** may be attached to the top of the sphere by suction, magnetic attraction or electroadhesion, for example. The turret has a linear groove or channel in which an intermediate portion of the cable **22** is placed. As the crawler vehicles **20a** and **20b** move in tandem around the spherical storage tank **102** at the same elevation and in the same direction, the turret of the pivot guide **15** rotates about an axis of rotation. At the same time, the groove or channel in which the cable **22** is seated constrain the cable **22** so that the cable **22** always passes over the highest point on the sphere and does not slide off, thereby enabling the crawler vehicles **20a** and **20b** to maintain opposed positions at any elevation as the crawler vehicles **20a** and **20b** travel circumferentially around the spherical surface **113**. The pivoting guide

15 could be dropped off and picked up by one of the crawler vehicles or it could be placed by some other means (such as a crane).

FIG. **2B** is a diagram representing a view of a storage tank **104** of different geometry undergoing automated maintenance using a pair of vacuum-adhered crawler vehicles **20a** and **20b** (equipped respectively with a cable spool **52** and a maintenance tool as previously described with reference to FIGS. **1A** and **1B**) connected to opposite ends of a cable **22**. In this case, the storage tank **104** has a vertical side surface **114** and a convex curved top surface **116**. As previously described with reference to FIG. **2A**, a pivoting guide (not shown in FIG. **2B**) may be attached to the highest point of the convex curved top surface **116** to prevent the cable **22** from sliding off during a maintenance procedure. FIG. **2B** depicts a scenario in which the crawler vehicles **20a** and **20b** are vacuum adhered to the vertical side surface **114** at the same elevation but in diametrically opposed positions. In this situation, crawler vehicle **20a** may perform a maintenance operation on the vertical side surface **114** of the storage tank **104**. Optionally, the tethered and vacuum-adhered crawler vehicles **20a** and **20b** depicted in FIG. **2B** may be used to perform a maintenance operation on the convex curved top surface **116** of the storage tank **104**. During such maintenance operations, the system may be operated to generate a tension in the cable **22** that exerts a gravity-compensating tensile force on the crawler vehicle **20b** as previously described with reference to FIGS. **1A** and **1B**.

FIG. **3A** is a diagram representing a top view of a cable-suspended crawler vehicle **20b** having a turret-mounted cable hook **3** in accordance with one embodiment. FIGS. **3B** and **3C** are side and end views respectively of the cable-suspended crawler vehicle **20b** depicted in FIG. **3A**. The crawler vehicle **20b** depicted in FIGS. **3A** and **3C** is suspended from a cable **22**. Preferably the shaft of the cable hook **3** is attached to the frame **2** at a point which is vertically aligned with a center-of-mass of the crawler vehicle **20b**. The crawler vehicle **20b** has four wheels **4** with respective axes of rotation that lie in a plane. This plane will be

referred to herein as the “crawler vehicle plane”. The crawler vehicle **20b** depicted in FIGS. **3A-3C** includes a maintenance tool **28** that is translatable along an axis that may be perpendicular to the crawler vehicle plane. This capability enables the maintenance tool **28** to be lifted over obstacles in the path of the crawler vehicle **20b**. In accordance with one embodiment, the means for translating the maintenance tool **28** normal to the confronting external surface of the structure undergoing maintenance may take the form of a motorized linear slide **31**. In the alternative, there are many different types of actuators that may be used with a linear motion bearing. For example, the maintenance tool **28** may be affixed to a carriage that is driven to slide by a linear actuator (e.g., a motorized lead screw, a motorized rack-and-pinion arrangement, a hydraulic actuator or a pneumatic actuator). In response to detection of an obstacle in the path of the crawler vehicle **20b**, a controller (not shown in FIGS. **3A-3C**) onboard or off-board the crawler vehicle **20b** activates the linear actuator to cause the maintenance tool **28** to translate to a retracted position whereat contact with the obstacle may be avoided.

As best seen in FIG. **3A**, the end of the cable **22** has a loop by means of which the crawler vehicle **20b** may be hooked onto the end of the cable **22**. The cable hook **3** is fixedly coupled to a turret **46** which is rotatable on a turret base **47** to facilitate alignment of the crawler vehicle **20b** with a surface. The turret base **47** is fixedly coupled to the frame **2**. In the proposed implementation depicted in FIGS. **3A-3C**, the turret base **47** is attached to one side of the frame **2** and the turret **46** is rotatable about an axis of rotation which is parallel to the axes of rotation of the wheels **4**. In an alternative proposed implementation (as depicted in FIGS. **1A** and **1B**), the cable **22** may be attached to one end of the frame **2**. More specifically, the turret base **47** depicted in FIG. **3A** may instead be attached to one end of the frame **2**, in which case the turret **46** is rotatable about an axis of rotation which is perpendicular to the axes of rotation of the wheels **4**.

FIG. **4** is a diagram representing a top view of a cable-suspended, vacuum-adhered, spool-equipped crawler vehicle **20a** in accordance with one

embodiment. The crawler vehicle **20a** has four wheels **4** with respective axes of rotation that lie in a plane. This plane will be referred to herein as the “crawler vehicle plane”. The crawler vehicle **20a** depicted in FIG. **4** includes a maintenance tool **28** that may be lifted in the manner previously described with reference to the crawler vehicle **20b** depicted in FIGS. **3A-3C**.

The crawler vehicle **20a** further includes a cable spool **52** which is rotatably coupled to a spool support **68**. The spool support **68** has an opening at the top where the cable **22** passes through a cable holder **56** that is inserted in the opening. During uptake or pay-out (i.e., winding or unwinding) of the cable **22**, the cable spool **52** is driven to rotate by a spool motor **54** that is mounted to the spool support **68**. The axis of rotation of the cable spool **52** is collinear with a spool axle (not shown in FIG. **4**, but see spool axle **50** in FIG. **14A**) of the cable spool **52**.

The spool support **68** in turn is fixedly coupled to a turret **46** which is rotatable on a turret base **47** to facilitate alignment of a crawler vehicle **20** with a surface. The turret base **47** is fixedly coupled to the frame **2**. The turret **46** is rotatable about an axis of rotation which is perpendicular to the spool axle **50** of the cable spool **52** and parallel to the crawler vehicle plane. Thus the spool support **68** is rotatable about an axis of rotation of the turret **46**.

Each of the crawler vehicles **20a** and **20b** further includes a multiplicity of motors (not shown in FIGS. **3A-3C** and **4**, but see FIG. **14A**) that receive electrical power via power/signal cords (not shown in FIGS. **1A** and **1B**) that extend from a ground-based control station to the crawler vehicles **20a** and **20b**. The power/signal cords also provide control signals from a controller (e.g., a computer system) at a ground-based control station which controls the operation of the motors on the crawler vehicles **20a** and **20b**. In cases where the maintenance tool **28** on crawler vehicle **20b** (and optionally on crawler vehicle **20a**) is an NDI sensor unit, the power/signal cord also provides a pathway for sending NDI sensor data acquired by the NDI sensor unit to ground-based controller.

In accordance with further alternative embodiments, the crawler vehicles **20a** and **20b** may communicate wirelessly with a ground-based control station while receiving electrical power from batteries mounted on the crawler vehicles **20a** and **20b**. This would avoid the use of a multiplicity of power/signal cords running from the crawler vehicles **20a** and **20b** to the ground-based control station. The wireless communications would include: (a) the sending of control signals from a transceiver at the ground-based control station to transceivers on the crawler vehicles **20a** and **20b**, which control signals are then forwarded to the motor controllers onboard crawler vehicles **20a** and **20b** for controlling movements of the crawler vehicles **20a** and **20b**; and (b) the sending of data acquired by the NDI sensor units onboard one or both crawler vehicles **20a** and **20b** from the transceivers onboard the crawler vehicles **20a** and **20b** to the transceiver at the ground-based control station.

Various embodiments of a crawler vehicle capable of traveling on level and non-level (e.g., inclined or vertical) surfaces will now be disclosed. In accordance with some embodiments of the system proposed herein, holonomic-motion crawler vehicles are employed. Various embodiments of a crawler vehicle capable of moving holonomically on level and non-level surfaces will be disclosed for the purpose of illustration. While some disclosed embodiments carry a non-destructive inspection sensor for inspecting the surface on which the crawler vehicle travels, the holonomic-motion crawler vehicles disclosed herein can alternatively carry other types of tools, such as tools needed in maintenance or painting operations.

FIG. **5** shows parts of a holonomic-motion crawler vehicle **20** having four Mecanum wheels and two suction zones in accordance with one embodiment. The electrical connections for supplying signals for controlling operation of the depicted components are not shown. This holonomic-motion platform comprises a frame **2** with four Mecanum wheels **4** (two type "A" and two type "B") mounted to the frame by means of respective wheel axles **6**, and further comprises four

independently controlled drive motors **8** (one per wheel). Each drive motor **8** controls the rotation of a respective wheel **4**.

A Mecanum-wheeled vehicle is a holonomic system, meaning that it can move in any direction while simultaneously rotating. This is possible because of the shape of the wheels. The standard configuration for a Mecanum-wheeled vehicle has four Mecanum wheels (two type "A" and two type "B"). The Mecanum wheels are arranged with the "A" pair on one diagonal and the "B" pair on the other, with each having its axle perpendicular to a line running through the center of the vehicle. The axes of the rollers on the type "A" Mecanum wheels are at right angles to the axes of the rollers on the type "B" Mecanum wheels. However, the platform may have any multiple of four Mecanum wheel, e.g., **4**, **8**, **12**, etc.

The holonomic-motion crawler vehicle **20** shown in FIG. **5** utilizes four Mecanum wheels **4a-4d**. Each Mecanum wheel **4a-4d** has a multiplicity of tapered rollers **16** rotatably mounted to its circumference, each tapered roller **16** being freely rotatable about its axis. These tapered rollers **16** have an axis of rotation which lies at a **45°** angle with respect to the plane of the wheel. Type "A" Mecanum wheels have left-handed rollers, while Type "B" Mecanum wheels have right-handed rollers. The holonomic-motion crawler vehicle **20** can be made to move in any direction and turn by varying the speed and direction of rotation of each Mecanum wheel **4a-4d**. For example, rotating all four wheels **4a-4d** in the same direction at the same rate causes forward or backward movement; rotating the wheels on one side at the same rate but in the opposite direction of the rotation by the wheels on the other side causes the vehicle to rotate; and rotating the Type "A" wheels at the same rate but in the opposite direction of the rotation of the Type "B" wheels causes sideways movement.

The embodiment depicted in FIG. **5** also has two suction devices arranged side by side in the middle of the frame **2**, midway between the front and rear wheels. In this particular embodiment, the suction devices are respective

electric ducted fans **10a** and **10b** which are mounted in a respective opening (not shown in FIG. **5**) formed in the frame **2**. As indicated in FIG. **14A**, each electric ducted fan **10a** and **10b** includes a fan **11** which is rotatable about an axis, a duct **9** surrounding the fan **11**, and an electric fan motor **13** which drives the fan **11** to rotate in a direction such that air is propelled from underneath the frame **2** up through the fan duct **9**, thereby creating suction in the respective suction zones **12a** and **12b** (visible in FIG. **6**).

FIG. **6** shows a bottom view of a Mecanum-wheeled crawler vehicle **20** having dual suction zones **12a** and **12b** separated by a middle skirt **14a** which bisects the bottom surface of the frame **2** along a longitudinal axis. As best seen in FIG. **6**, the two suction zones **12a** and **12b** are bounded on opposing sides by longitudinal low-surface-friction flexible skirts **14b** and **14c** which are attached to the frame **2**, the middle skirt **14a** forming a common boundary wall separating the two suction zones **12a** and **12b**. The skirts **14a-14c** may extend downward so that their bottom edges contact the surface on which the vehicle is moving.

In this particular construction, the area of the bottom surface between skirts **14a** and **14b** comprises a flat central surface **36a** having an opening of one electric ducted fan **10**. This flat central surface **36a** is flanked by forward and rearward convex surfaces **38a** and **40a**. Similarly, the area of the bottom surface between skirts **14a** and **14c** comprises a flat central surface **36b** having an opening of one electric ducted fan **10**. This flat central surface **36b** is flanked by forward and rearward convex surfaces **38b** and **40b**. Each of the convex surfaces **38a**, **38b**, **40a** and **40b** may be an aerodynamically streamlined surface which forms a respective throat with opposing portions of the surface on which the vehicle is moving. Thus, the contoured bottom surface of the frame **2**, the skirts **14a-14c** and the inclined surface **111** on which the crawler vehicle **20** is moving define respective channels that allow sufficient air to be sucked up through the corresponding electric ducted fan **10a** or **10b** to generate a desired suction force. The portion of each channel between the lowest points of the convex surfaces **38a**, **38b**, **40a** and **40b** forms respective

suction zones **12a** and **12b**. In the particular embodiment depicted in FIG. **6**, the suction zones **12a** and **12b** are separated by the middle skirt **14a** and are in fluid communication with the respective openings in which the electric ducted fans **10a** and **10b** are installed. These openings may be substantially conical along a lowermost portion thereof to facilitate the flow of air out the suction zone.

It should be appreciated that the under-body surface shape seen in FIG. **6** is an exemplary implementation. The under-body surface may have many different shapes conducive to the flow of air from the front and rear of the crawler vehicle **20** through the space underneath the crawler vehicle **20** and then up through the ducts **9** of the electric ducted fans **10a** and **10b**.

Although not shown in FIG. **5**, the holonomic-motion crawler vehicle **20** can be tethered to a support system by a cable which supplies electrical power to the drive motors **8** and electric ducted fans **10a** and **10b** on the vehicle. The cable also provides control signals to an onboard computer **44** (see FIG. **14A**) which controls the operation of the drive motors **8** and electric ducted fans **10**. The onboard computer **44** communicates with respective motor controllers **85** which control the operation of the drive motors **8** and electric ducted fans **10**. In accordance with one embodiment, the drive motors **8** are stepper motors. For example, each motor controller **85** may include an indexer (e.g., a microprocessor) configured to generate step pulses and direction signal for a driver which is also part of the motor controller. The driver converts the indexed command signals into the power necessary to energize the motor windings. A stepper motor is an electromagnetic device that converts digital pulses into mechanical shaft rotation. The onboard computer **44** may further include a computer or processor for commanding and orchestrating the motor controllers. The holonomic-motion crawler vehicle **20** may further include a converter box (not shown) mounted to the frame **2**. The converter box converts USB signals from the onboard computer **44** into pulse-width-modulated (PWM) signals for controlling the fan motors **13** (see FIG. **14A**).

In accordance with an alternative embodiment, the crawler vehicle **20** could be battery-powered, instead of receiving electrical power via a power/signal cord. Also the motor controllers (not shown in FIG. **5**, but see motor controllers **85** in FIG. **14A**) could be under the control of an onboard computer (not shown in FIG. **5**, but see onboard computer **44** in FIG. **14A**) rather than a ground-based computer. Alternatively, the motors onboard the crawler vehicle **20** can be controlled via a wireless connection to an off-board controller.

The frame **2** of the crawler vehicle **20** requires some amount of compliance to keep all of the wheels **4** in contact with a surface without slipping. If only three of the four wheels **4** are in contact with the surface and can generate traction, the crawler vehicle **20** will not respond properly to motion inputs. One way to address the wheel contact issue is to build a frame with low torsional stiffness. Another way is to provide suspension for one or more of the wheels.

For a Mecanum-wheeled vehicle to function properly on an inclined or vertical surface, there are additional issues that need to be addressed, specifically, in order to generate the proper vehicle motion, the forces on the wheels need to be sufficient to generate the required traction. If one or more of the wheels begin to slip or stall, the required forces at that corner of the vehicle will not be produced, resulting in an undesired overall vehicle motion.

To ensure sufficient traction, the crawler vehicle **20** may be provided with multiple suction or vacuum creation devices (e.g., electric ducted fans **10a** and **10b**) attached to respective openings in the frame **2** to create respective suction zones **12a** and **12b** that can be controlled independently. These independently controlled suction zones **12a** and **12b** allow the system to control the amount of normal force exerted on the wheels **4a-4d** by the contacting surface, which in turn determines the amount of frictional force being exerted in opposition to the weight of the crawler vehicle **20**.

As depicted in FIG. 6, the underside of the frame 2 is shaped to provide two suction zones 12a and 12b. Also the frame 2 has low-surface-friction skirts 14a-14c that conform to non-flat surfaces. The electric ducted fans 10a and 10b are installed in respective openings in the frame 2 and are in fluid communication with respective suction zones 12a and 12b defined by the frame bottom surface and the skirts 14a-14c. When the electric ducted fans 10a and 10b are turned on, each electric ducted fan propels air upward, thereby sucking air from the shaped suction zones 12a and 12b respectively. The electric ducted fans 10a and 10b can be independently controlled to apply different suction forces to the confronting surface underneath the respective suction zones 12a and 12b.

FIG. 7A is a diagram representing a view of a holonomic-motion crawler vehicle 20g that uses vacuum adhesion technology and holonomic wheels to adhere and be mobile on non-magnetic surfaces. Crawler vehicle 20g may be equipped with a maintenance tool 28 (such an NDI sensor unit) mounted to a gimbal 33 having two rotational degrees of freedom. The crawler vehicle 20g adheres to non-magnetic surfaces through a dual vacuum assist system along with eight vacuum adherence devices that each form a vacuum seal. These vacuum adherence devices are dragged along the surface when the crawler vehicle 20g is in motion. This adhesion mechanism has no issue navigating or adhering to flat surfaces and can maintain attachment to the surface at all angles.

FIG. 7A shows a holonomic motion crawler vehicle 20g that has four Mecanum wheels 4a-4d (only wheels 4b and 4d are visible in FIG. 7A), four omnidirectional wheels (hereinafter "omni wheels"; only omni wheel 45a is visible in FIG. 7A), two suction zones under the vehicle (not shown), and respective sets of three LED lights 136a-136c on each side (only one set is visible in FIG. 7A). In accordance with the embodiment depicted in FIG. 7A, the LED lights 136a-136c are arranged in an asymmetric pattern on the cover of the crawler vehicle. Each LED light has a generally hemispherical bulb that projects above the cover 138 of the crawler vehicle 20g.

FIG. 7B is a diagram representing a bottom view of the holonomic-motion crawler vehicle depicted in FIG. 7A. The holonomic-motion crawler vehicle **20g** has a multiplicity of vacuum adherence devices **150**. For example, the multiplicity of vacuum adherence devices **150** may include a first set **151a** of four vacuum adherence devices **150** arranged in a first row and a second set **151b** of four vacuum adherence devices **150** arranged in a second row which is parallel to the first row. Other configurations for placement of the vacuum adherence devices **150** are possible. The vacuum adherence devices **150** are configured to provide enhanced adherence of the crawler vehicle **20g** to the convex curved contours of an external surface **111**.

A location tracking system can be provided which is capable of measuring the location of crawler vehicle **20g** in absolute coordinates following the completion of a motion that was tracked incrementally, e.g., using rotation encoders **48** (see FIG. 14A) operatively coupled to a set of four omni wheels **45a-45d**. One example of an incremental motion measurement system is a dead-reckoning odometry-based system. Any dead-reckoning solution will have measurement inaccuracies due to small errors that build up over time. These can be caused by systematic errors in the device or disruptions caused by unexpected changes in the environment.

This device depicted in FIG. 7B has a four-omni wheel, perpendicular, double-differential configuration. Respective rotation encoders **48** measure rotation of the omni wheels **45a-45d**. As the omni wheels **45a-45d** roll on a surface, the rotation encoders **48** send encoder pulses representing respective encoder counts to an operations control center via a power/signal cable (not shown in FIGS. 7A and 7B) after each incremental rotation of each omni wheel. Each rotation encoder **48** will output an encoder count proportional to the angle of rotation of a respective omni wheel. These encoder pulses will be received by a computer system (see, e.g., onboard computer **44** depicted in FIG. 14A) that computes the X and Y coordinates of the device.

The control system stops the device when the counts of encoder pulses indicate that the device has arrived at the desired location. The current location of the stopped device can then be checked to determine to what extent it may deviate from the desired location. In accordance with the teachings herein, corrections can be made to the relative motion measurements by acquiring accurate, absolute measurements at lower update rates. This absolute measurement process (performed while the target object is stopped) can be integrated into a relative motion measurement system running at higher update rates, which acquires relative motion measurements while the target object is moving. In accordance with one embodiment disclosed hereinafter, a lower-update-rate local positioning system-based process provides corrections to a higher-update-rate odometry system.

A process for absolute measurement of the position of the crawler vehicle **20g** is implemented by acquiring an image with the LED lights **136a-136c** off and then turning the lights on and acquiring another image (or *vice versa*). Two variations of the process have been developed: one in which all the lights are turned on at the same time, and another in which the lights are turned on in a specific sequence. The first way is slightly faster. It employs a light pattern on the surface of the target object that is asymmetric. The second method is more robust in differentiating between the lights and does not require the light pattern to be asymmetric. The absolute measurement system (not shown in the drawings) includes a laser range meter mounted to a pan-tilt unit that produces position and orientation data at finite time intervals.

FIG. **8A** is a diagram showing a cross-sectional view of a vacuum adherence device **150** in accordance with one implementation. This vacuum adherence device **150** comprises a circular cylindrical sleeve housing **152** and a sleeve **154** having a circular cylindrical portion which is axially slidable along a center axis **166** inside the sleeve housing **152**. The sleeve **154** further comprises bearing portion **156** having an outer spherical bearing surface having a center point located along the center axis **166**. The bearing portion **156** may be integrally

formed with the aforementioned circular cylindrical portion of sleeve **154**. The vacuum adherence device **150** further comprises a pivotable seal assembly **158** comprising a socket ring **160** that holds a seal **162**. The socket ring **160** also has an inner spherical bearing surface which is concentric with and pivotably coupled to the outer spherical bearing surface of bearing portion **156** of sleeve **154**. The pivot point of the socket ring **160** is collocated with the center point of the outer spherical bearing surface of bearing portion **156** of sleeve **154**.

The pivotable seal assembly **158** is configured to rotate relative to the sleeve **154** about the pivot point to at least partially conform to a shape of a confronting surface. The vacuum adherence device **150** can adhere to such a confronting surface when air is drawn into a channel **164** formed in part by the channel of sleeve housing **152**, in part by the channel of sleeve **154**, and in part by the opening in the seal **162**. The pivotable seal assembly **158** is configured to rotate relative to the sleeve **154** independently of translational movement of the sleeve **154** in a direction parallel to the center axis **166** within the sleeve housing **152**. The amount of rotation of pivotable seal assembly **158** may be limited by the size and/or shape of the outer spherical bearing surface of the bearing portion **156** of sleeve **154**.

Although not shown in FIG. **8A**, the vacuum adherence device **150** preferably comprises a spring arranged to urge the sleeve **154** to extend out of the sleeve housing **152** by downward (as seen in the view of FIG. **8A**) sliding along the center axis **166**. This sliding movement may be restricted to within a selected range of movement. However, sleeve **154** may “float” freely relative to sleeve housing **152** within this selected range of movement. This restriction of the translational motion of sleeve **154** can be implemented by providing a slot **168** in the wall of the circular cylindrical portion of sleeve **154** and by providing a pin **170** which extends radially inward from the wall of sleeve housing **152** and into the slot **168**. The pin **170** may also be used to hold sleeve **154** inside sleeve housing **152**.

The length of slot **168** restricts the sliding movement of sleeve **154** relative to sleeve housing **152**.

5 The channel **164** is in fluid communication with a control valve (not shown in FIG. **8A**), which control valve is in turn in flow communication with a vacuum pump (also not shown in FIG. **8A**). The vacuum pump, control valve, channel **164**, and connecting conduits form a vacuum system which is configured to draw air into the channel **164** such that a vacuum adherence is formed between the pivotable seal assembly **158** and a confronting surface. The vacuum adherence is the result of a vacuum pressure generated inside the channel **164**. When the flow of air is reversed, air provided by the pump flows through any gap between the seal **162** and the confronting external surface **111**. The height of the gap may vary along the periphery of the seal **162**. This gap height depends on the shape of the confronting surface and the degree of rotation of the seal **162** to conform to that shape. The seal **162** may be formed of any one of a number of different materials. 10 For example, seal **162** may comprise silicone rubber or other elastomeric material, a viscoelastomeric material, or some other suitable flexible material. 15

FIG. **8B** shows a cross-sectional view of the vacuum adherence device **150** depicted in FIG. **8A** adhered to a convex curved external surface **111**. The air gap between the vacuum adherence device **150** and the external surface **111** has been exaggerated for the purpose of illustration. The air gap may function as an air bearing that holds the pivotable seal assembly **158** close to the external surface **111**, while reducing static friction to within selected tolerances. In other words, the air gap allows pivotable seal assembly **158** to “float” above the external surface **111** while maintaining vacuum adherence between pivotable seal assembly **158** and external surface **111**. Further, the air gap allows pivotable seal assembly **158** to be moved over the external surface **111** with a reduced amount of static friction and without causing undesired effects to the surface. 20 25

In one embodiment, the seal **162** may be corrugated in such a way as to allow small channels for airflow between the seal **162** and the external surface **111**. In some instances, these corrugated channels have been shown to promote vacuum on surfaces of uneven profile or varying surface roughness. In accordance with this embodiment, the corrugations may comprise a low-friction material that further induces sliding such that base motion will be enabled, yet airflow is ensured by the corrugated channels.

The ability to control the respective suction forces produced allows the load on the wheels **4a-4d** in the direction perpendicular to the surface normal to be controlled, which in turn provides the ability to increase the lateral force on the wheels **4a-4d** through the equation $F = \mu N$, where F is the lateral force due to friction, μ is the coefficient of friction, and N is the normal force.

FIG. **9** is a diagram showing the forces exerted by a horizontal surface on the Mecanum wheels **4a-4d** of the crawler vehicle **20** depicted in FIGS **5** and **6**. (The principles depicted in FIGS. **9** and **10** are equally applicable to the crawler vehicle **20g** depicted in FIGS. **7A** and **7B**.) When the suction forces generated by the respective electric ducted fans **10a** and **10b** are equal, the normal forces on the Mecanum wheels **4a-4d** on the left- and right-hand sides of the vehicle are equal, i.e., $N_1 = N_2$.

FIG. **10** is a diagram showing the forces exerted by an inclined surface **111** on wheels **4a** and **4c** (wheel **4c** is directly behind wheel **4a** and not visible in FIG. **10**) and on wheels **4b** and **4d**. The speed of the electric ducted fans **10a** and **10b** can be controlled to produce different suction forces on opposite sides of the crawler vehicle. When the suction force generated by the electric ducted fan **10** disposed at a relatively higher elevation is greater by a certain amount than the suction force generated by the electric ducted fan **10** disposed at a relatively lower elevation, the frictional and normal forces exerted by the inclined surface **111** on the upper pair of wheels **4a** and on the lower pair of wheels **4b** can be equalized, i.e.,

$F_1' = F_2'$ and $N_1' = N_2'$. Thus the suction in the upper zone can be increased relative to that of the lower zone, resulting in an increase in the normal load on the two upper Mecanum wheels **4a** and **4c**. The respective electric ducted fans **10a** and **10b** are controlled as a function of the angle of inclination of the inclined surface **111** on which the vehicle is situated. The balance between the zones **12** can be controlled by using a sensor (not shown), such as an electronic inclinometer sensor, installed on the frame **2** to measure the relative angle between the frame **2** and the gravity vector mg (where m is the mass of the crawler vehicle **20**). The electronic inclinometer sensor returns angle of inclination data to the controller, which uses the data for controlling the electric ducted fans **10**. Thus slippage of the crawler vehicle will not occur so long as the total gravity-compensating force $F_1' + F_2'$ is greater than or equal to the lateral component (parallel to the inclined surface **111**) of the gravitational force vector mg , where m is the total mass of the crawler vehicle **20** and the length of cable (not shown in FIG. **10**) between the crawler vehicle **20** and the cable spool **52**, and g is acceleration due to gravity.

Although not shown in FIG. **10**, the frame **2** of the crawler vehicle **20** may be fastened or hooked onto one end of a cable **22**, as depicted in FIGS. **3A-3C**. The arrow labeled F_{cable} seen in FIG. **10** represents an additional gravity-compensating tensile force being exerted by a cable from which the crawler vehicle **20** is suspended. Thus slippage of the crawler vehicle will not occur so long as the total compensation force $F_1' + F_2' + F_{\text{cable}}$ is greater than or equal to the lateral component of the gravitational force vector mg . Due to the force F_{cable} applied by the cable, the magnitudes of the lateral frictional forces F_1' on the two upper Mecanum wheels **4a** and **4c** and F_2' on the two lower Mecanum wheels **4b** and **4d** may be reduced, which in turn reduces the magnitudes of the suction forces needed to prevent downward slippage of the crawler vehicle **20**. Because smaller forces may be employed, the maximum power and the accompanying mass of the fan motors **13** may be reduced, thereby reducing the mass and cost of each crawler vehicle. Also,

if the crawler vehicle **20** is battery-powered, the anti-gravity assistance provided by a tensioned cable attached to the frame **2** reduces the rate at which electric power is consumed, which in turn extends the operating time until the battery should be recharged.

5 With a holonomic-motion system that can move on level, inclined and vertical surfaces, general-purpose motion control is enabled for inspection and other types of applications. For the types of inspection applications envisioned, having holonomic motion control allows the system operator to use efficient path planning.

10 While making a rotation maneuver as described above on an inclined or vertical surface, the suction in the multiple zones under the Mecanum-wheeled vehicle will be automatically changed by the control software or hardware as the wheel loads in the normal direction change. The change in suction is performed in order to achieve balanced loads on the wheels. Suction in the various zones may also change as the vehicle moves over a curved surface. In some embodiments, the
15 relative amounts of suction in each zone are controlled by using data from a gravity vector sensing device, such as an inclinometer. In other embodiments, load sensors for each wheel may be used to determine the required amount of suction. In addition, this information may be used to calculate the angle of rotation of the cable spool **52** on the crawler vehicle **20a** (see FIGS. **1A** and **1B**) that will produce a
20 desired additional gravity-compensating force F_{cable} .

 The crawler vehicles **20** disclosed herein have multiple applications. In accordance with one application, the crawler vehicle **20** carries an eddy-current sensor, but other types of sensors, such as ultrasonic sensors can be carried. The sensor may be a single sensing element or an array of sensing elements. Cameras,
25 tools, painting equipment, a laser marking system, a robotic arm manipulator, or other devices could also be carried by the platform.

FIG. 11A shows a version of the crawler vehicle **20** with a fixed ultrasonic transducer array **88** mounted to one end of the frame **2**. The ultrasonic transducer array **88** can scan an underlying surface in the direction in which the vehicle crawls. The ultrasonic sensor may be a single ultrasonic sensing element or an array of ultrasonic sensing elements.

FIG. 11B shows another version of the crawler vehicle **20** with a scanning ultrasonic sensor unit **30** (e.g., a linear or curved ultrasonic transducer array) mounted on a linear track **32** fixed to one end of the frame. The ultrasonic sensor unit **30** can slide back and forth along the linear track **32**, scanning a transverse area of underlying surface while the crawler vehicle **20** is stationary. Again, the ultrasonic sensor may be a single sensing element or an array of sensing elements. The vehicle can be moved forward in increments, pausing after each incremental move to allow the ultrasonic sensor unit **30** to scan along a transverse line. Alternatively, a controller can be programmed to control the movements of the crawler vehicle **20** and the scanning head to provide other patterns for scanning a surface area.

FIGS. 12A-12D are diagrams representing top views of a holonomic-motion crawler vehicle **20e** in accordance with an alternative embodiment which has a passive connection that pivots about an axis of rotation **R1** (see FIG. 13) that is perpendicular to the frame **2** and passes through the center of mass of the crawler vehicle **20e**, with an arm **132a** that is shaped to allow the cable force to project through the center of mass of the crawler vehicle **20e** (but not interfere with the crawler or the sensor payload). More specifically, crawler vehicle **20e** includes: a center pivot **134a** that is rotatably coupled to the frame **2** and rotates about the axis of rotation **R1**; an arm **132a** having one end affixed to the center pivot **134a**, a turret base **47** affixed to the other end of the arm **132a**; a turret **46** rotatably coupled to the turret base **47**; and a cable **22** having one end attached or tied to the turret **46**. FIGS. 12A through 12D depict the crawler vehicle **20e** in respective angular positions at

respective instants of time during counterclockwise rotation of the frame **2** about axis of rotation **R1**.

FIG. **13** is a diagram representing a side view of a pair of holonomic-motion crawler vehicles **20e** and **20f**. Crawler vehicle **20f** includes: a center pivot **134b** that is rotatably coupled to the frame **2** and rotates about a vertical axis **R2** that passes through the center of mass of the crawler vehicle **20f**; an arm **132b** having one end affixed to the center pivot **134b**, and a cable spool **52** that is rotatably coupled to the other end of the arm **132b**. A cable **22** has one end wound on the spool **52** and the other end attached or tied to the turret **46** of the crawler vehicle **20e**. Although crawler vehicles **20e** and **20f** are shown on a flat surface in FIG. **13**, they may be placed on an aircraft fuselage **100** in a manner similar to placement of crawler vehicles **20a** and **20b** depicted in FIGS. **1A** and **1B**. During the performance of a maintenance operation, the movement of tool-equipped crawler vehicle **20b** may be tracked using any one of a variety of crawler vehicle position measurement systems. Knowing where each crawler vehicle is located at any time is important. For example, in cases where the maintenance tools are NDI sensor units, the locations of the NDI sensor units are correlated with the acquired NDI sensor data to ensure full coverage and potentially create an NDI map of the external surface **112** of the aircraft fuselage **100** (or other body).

(a) The crawler vehicle **20b** may be equipped with omnidirectional wheels and omni wheel rotation encoders to enable vertical and horizontal movements to be tracked.

(b) Laser-based methods may be used. For example, a laser-based crawler vehicle position measurement system may include laser range meters mounted on a cart and aimed at optical targets mounted on each crawler vehicle **20a** and **20b**.

(c) Camera- or video-based methods may be used, such as motion capture using optical targets mounted on each crawler vehicle **20a** and **20b**.

FIG. 14A is a block diagram identifying some components of a holonomic-motion crawler vehicle that is equipped with both a cable spool 52 and a carriage-mounted maintenance tool (only the carriage 34 is shown in FIG. 14A) in accordance with one embodiment. This spool- and tool-equipped holonomic-motion crawler vehicle includes a frame 2 having a set of four wheel axles 6 fixedly coupled thereto. A set of four Mecanum wheels 4 are rotatably coupled to respective wheel axles 6. A set of four drive motors 8 are configured to respectively drive rotation of the Mecanum wheels 4 in response to control signals received from respective motor controllers 85. The motor controllers 85 in turn receive commands from an onboard computer 44. The onboard computer 44 is programmed to receive operational instructions from a ground-based control computer via a transceiver 80 and then issue commands in the formats recognized by the motor controllers 85. In addition, a pair of electric ducted fans 10a and 10b are incorporated in the frame 2. (In alternative embodiments, the number of electric ducted fans may be different than two.) Each electric ducted fan 10a and 10b includes a fan 11 which is rotatable about an axis, a duct 9 surrounding the fan, and an electric fan motor 13 which drives the fan 11 to rotate in response to control signals received from the onboard computer 44. The holonomic-motion crawler vehicle partly represented in FIG. 14A further includes a spool axle 50 fixedly coupled to the frame 2, a cable spool 52 rotatably coupled to the spool axle 50, and a spool motor 54 configured to drive rotation of the cable spool 52 in response to control signals received from the onboard computer 44. In addition, the holonomic-motion crawler vehicle partly represented in FIG. 14A includes a linear track 32 mounted to the frame 2. More specifically, the linear track 32 may be translatably coupled to a motorized linear slide 31 of the type depicted in FIG. 3B. A carriage 34, to which the maintenance tool 28 (not shown in FIG. 14A) is fixedly coupled, is translatably coupled to the linear track 32 and driven to translate laterally along the linear track 32 by a carriage motor 42 (by way of a gear train not shown) in response to control signals received from the onboard computer 44.

In addition, the onboard computer **44** may be programmed to track the location of the crawler vehicle using differential odometry. (In this context, the term "location" includes position in a three-dimensional coordinate system and orientation relative to that coordinate system.) For this purpose, the crawler vehicle components depicted in FIG. **14A** include a set of omni-directional wheels **45** with respective rotation encoders **48**. The encoded data output by the rotation encoders **48** is received by the onboard computer **44**. In accordance with the teachings herein, a frame **2** of a crawler vehicle may have a set of four omni-directional wheels **45** for tracking vehicle motion and a set of four Mecanum wheels **4** for driving the vehicle under the control of the onboard computer **44**. More details regarding such a subsystem for differential odometry can be found in U.S. Patent No. **9,470,658**.

All of the motors identified in FIG. **14A** are mounted to the frame **2**. The onboard computer **44** is configured to control operation of the motors so that each holonomic-motion crawler vehicle performs a maintenance operation in a respective area of the surface of the aircraft fuselage **100**. The onboard computer **44** receives data from sensor(s) **82**. The sensor(s) **82** may, e.g., include an inclinometer that provides data representing the angle of inclination of the holonomic-motion crawler vehicle or respective sensors that provide data representing the loads on each wheel. The onboard computer **44** processes that information to: (1) control the drive motors **8** as a function of the position/orientation data and (2) control the electric ducted fans **10a** and **10b** as a function of the sensor data as disclosed in U.S. Patent No. **8,738,226**.

The onboard computer **44** is also programmed to control operation of the spool motor **54** to provide anti-gravity assistance via a cable to another crawler vehicle as described in detail above. For example, the onboard computer **44** may be programmed with a "position control" mode in which there is direct feedback between the rotation encoders **48** (or some other length-based measurement sensor) and the spool motor **54**. This drives the spool motor **54** to rotate to produce

the desired length of cable **22** using a feedback control mode such as Proportional-Integral-Derivative (PID) control.

5 In accordance with one alternative embodiment, another way that the motorized winch can be setup to work is to use a "torque control" or "force control" mode. In this case the motor power is pre-set to produce a specific amount of torque—which is equivalent to a specific amount of force on the cable **22**. This is a simpler mode than the "position control" mode discussed above. The torque control allows the desired load to be set and kept that way, while the crawler vehicle **20b** produces all of the desired motion control for the scanning tasks.

10 In accordance with a further alternative embodiment, a passive winch with a constant force tensioning spring (such as the tensioning spring **86** identified in FIG. **18A**) can be used. A passive winch produces a similar result to the "torque control" mode mentioned above, with the spring load pre-set. The tensioning spring **86** exerts a gravity-compensating tensile force without any power applied.

15 An advantage of torque control over a tensioning spring may be that the operator can change the amount of power supplied to the spool motor **54** when conditions demand, such as if the slope of the surface changes and less or more torque is wanted, or if additional cable has been paid out and the torque should be increased to compensate for the extra weight of the cable. Also, the control mode of
20 the spool motor **54** can be easily changed to an active or manual control mode if the operator needs to move the crawler vehicle in a different way for some reason (such as extricate the crawler vehicle from a jam if the crawler vehicle becomes stuck).

25 It is also possible to have a motorized winch with passive spring, which may have all the advantages of the motorized winch, with passive gravity compensation to reduce the power needed to run the system.

In general, gravity compensation will be determined based on the weights of the crawler vehicle and length of paid-out cable and the slope of the

inclined surface **111**. To calculate the total compensation force, the following equation may be used:

$$F_1' + F_2' + F_{\text{cable}} = (m_{\text{cv}} + m_{\text{cable}}) * g * \sin(\text{angle})$$

5 where m_{cv} is the mass of the crawler vehicle, m_{cable} is the mass of the length of cable between the crawler vehicle **20b** and the cable spool **52**, g is acceleration of gravity, and $\sin(\text{angle})$ is the sine of the angle of the inclined surface relative to a horizontal plane (where a vertical wall would be **90** degrees and $\sin(90) = 1$).

The mass of the paid-out length of cable **22** changes as more cable is paid out, so for the passive winch device, the operator may set the spring tension for some average paid-out cable length. For the motor-based torque control method, the operator may adopt a torque change based on the length of the cable that has been paid out (if the optional length measurement sensor is used).

10 Referring back to FIG. 1A, it should be appreciated that the crawler vehicle **20a** may have all of the components depicted in FIG. 14A or may have all of the components depicted in FIG. 14A except for the linear track **32**, carriage **34** (with a maintenance tool mounted thereto) and carriage motor **42**. In contrast, the crawler vehicle **20b** has all of the components depicted in FIG. 14A except for the spool axle **50**, cable spool **52** and spool motor **54**.

20 FIG. 14B is a block diagram identifying some components of a gravity-compensating system in which two cable-connected crawler vehicles **20a** and **20b**, vacuum adhered to a body (e.g., an aircraft fuselage **100**), communicate wirelessly with a ground-based control computer **90**. The control computer **90** is programmed to output operational instructions in digital format to a transceiver **80c**, which converts the digital data into modulated waveforms which are then broadcast as radiofrequency signals by an antenna (not shown in FIG. 14B). The broadcast radiofrequency signals are received by respective antennas (not shown in FIG. 25 **14B**) mounted on the crawler vehicles **20a** and **20b** and the resulting modulated

waveforms are demodulated by transceivers **80a** and **80b**, which respectively output digital data representing the operational instructions to respective onboard computers **44**. The onboard computers **44** then send commands to the motor controllers **85** that cause the crawler vehicles **20a** and **20b** to operate in accordance with the operational instructions.

FIG. **15** is a diagram representing a front end view of an aircraft fuselage **100** at an instant in time during an automated maintenance procedure performed using a gravity-compensating system in accordance with a second embodiment. The gravity-compensating system includes a spool-equipped crawler vehicle **18** suspended by an umbilical cable **24** from a boom **27** and vacuum adhered to an external surface **112** of the aircraft fuselage **100**. The crawler vehicle **18** may be configured to move holonomically. The system depicted in FIG. **15** further includes tool-equipped crawler vehicles **20c** and **20d** connected to the spool-equipped crawler vehicle **18** by respective cables **22a** and **22b** and vacuum adhered to the external surface **112** of the aircraft fuselage **100** on opposite sides thereof. The crawler vehicles **20c** and **20d** are also configured to move holonomically. It should be appreciated that the cables **22a** and **22b**, which are depicted in FIG. **15** as being at a constant distance from the external surface **112**, in actuality may contact the external surface **112** in an area midway between the crawler vehicles connected by the cable.

Still referring to FIG. **15**, a pulley **26** is rotatably coupled to a distal end of the boom **27** to facilitate pay-out and take-up of the umbilical cable **24** in the manner described in U.S. Patent No. **9,410,659**. A power/signal cord (not shown in FIG. **15**) may be attached to or incorporated in the umbilical cable **24** for enabling a ground-based control computer to communicate with a computer onboard the crawler vehicle **18** and for supplying electrical power to the crawler vehicle **18**. Similarly, respective power/signal cords (not shown in FIG. **15**) may be attached to or incorporated in the cables **22a** and **22b** for enabling the computer onboard the crawler vehicle **18** to communicate with the computers onboard the crawler

vehicles **20c** and **20d** and for supplying electrical power to the crawler vehicles **20c** and **20d**.

In accordance with the embodiment depicted in FIG. **15**, the crawler vehicle **18** has two cable spools **52a** and **52b**, one cable spool **52a** having one end of the cable **22a** attached thereto and some portion of the cable **22a** wound thereon, while the other cable spool **52b** has one end of the cable **22b** attached thereto and some portion of the cable **22b** wound thereon. The other end of the cable **22a** is attached to the frame **2** of the crawler vehicle **20c**, while the other end of the cable **22b** is attached to the frame **2** of the crawler vehicle **20d**. In accordance with the arrangement depicted in FIG. **15**, the computer onboard the crawler vehicle **18** may control the motor-driven rotation of the respective cable spools **52a** and **52b** to concurrently apply additional gravity-compensating forces to the crawler vehicles **20c** and **20d** via respective cables **22a** and **22b** in the manner described above. In an alternative embodiment, the cable spools **52a** and **52b** on crawler vehicle **18** may be torqued using tensioning springs. Thus the crawler vehicle **18** only manages the cables **22a** and **22b** and acts as a power source and communication relay with respect to the tool-equipped crawler vehicles **20c** and **20d**.

FIG. **16** is a diagram representing a front end view of an aircraft fuselage **100** at an instant in time during an automated maintenance procedure performed using a gravity-compensating system in accordance with a third embodiment that includes a crawler vehicle **18a** which is connected to a pair of tool-equipped crawler vehicles **20c** and **20d** by means of respective cables **22a** and **22b**. It should be appreciated that the cables **22a** and **22b**, which are depicted in FIG. **16** as being at a constant distance from the external surface **112**, in actuality would contact the external surface **112** in an area midway between the crawler vehicles connected by the cable.

Still referring to FIG. 16, the crawler vehicle 18a is equipped with a pair of cable spools 52a and 52b for providing gravity compensation and a wireless communication system (including an antenna 72) for enabling two-way communication with a ground-based control computer (not shown in FIG. 16, but see control computer 90 in FIG. 17). The crawler vehicle further includes batteries (not shown in FIG. 16) for providing electrical power to itself and to the crawler vehicles 20c and 20d via respective power/signal cords attached to or incorporated in cables 22a and 22b. All of the crawler vehicles 18a, 20c and 20d may be configured to move holonomically. Such movements may be synchronized by the computer onboard the crawler vehicle 18a, which is configured to send operational instructions to the computers onboard the crawler vehicles 20c and 20d. In accordance with the arrangement depicted in FIG. 16, the computer onboard the crawler vehicle 18a also controls the motor-driven rotation of the respective cable spools 52a and 52b to concurrently apply additional gravity-compensating forces to the crawler vehicles 20c and 20d via respective cables 22a and 22b in the manner described above.

FIG. 17 is a block diagram identifying some components of a system for performing an ultrasonic inspection on a surface of a body in accordance with one proposed computer architecture. For example, the NDI sensor unit may be an ultrasonic transducer array 88. As previously disclosed above, the system may include a control subsystem that uses rotation encoders to track the relative location (e.g., relative to an initial location acquired using a local positioning system) of the ultrasonic transducer array 88. More specifically, the control system includes a ground-based control computer 90 programmed with motion control application software 92 and NDI scan application software 94. The control computer 90 may be a general-purpose computer programmed with motion control application software 92 including respective software modules for sending instructions to the computers onboard the crawler vehicles 18a, 20c and 20d. Those onboard computers in turn output commands to the motor controllers onboard the crawler vehicles 18a, 20c and

20d, including: (a) two motor controllers onboard the crawler vehicle **18a** that control operation of two onboard spool motors; and (b) at least four motor controllers on each crawler vehicle that control operation of the motors for coordinating movements of the crawler vehicles **18a**, **20c** and **20d** along respective scan paths during an ultrasonic inspection. The motion control application software **92** sends commands based on feedback from a position measurement system **84** that tracks the locations of the crawler vehicles **18a**, **20c** and **20d**. The feedback from the position measurement system **84** is also provided to an ultrasonic pulser/receiver **96**, which may be connected to the ultrasonic transducer arrays **88** on crawler vehicles **20c** and **20d** via an electrical cord or cable or wirelessly.

Still referring to FIG. **17**, the ultrasonic pulser/receiver **96** sends the encoder pulses to the NDI scan application software **94**. The NDI scan application software **94** uses the encoder values to position the scan data in the proper location. The control computer **90** hosts ultrasonic data acquisition and display software that controls the ultrasonic pulser/receiver **96**. The ultrasonic pulser/receiver **96** in turn sends pulses to and receives return signals from the ultrasonic transducer arrays **88**. The NDI scan application software **94** controls all details of the scan data and the display of data, including the stitching of data acquired during adjacent sweeps of an ultrasonic transducer array **88**.

The position measurement system **84** is configured to acquire position data representing the initial coordinate position of each of the crawler vehicles **20c** and **20d** relative to a coordinate system (i.e., frame of reference) of the aircraft fuselage **100**. Once the initial coordinate position of each of the crawler vehicles **20c** and **20d** has been determined, the data acquired by the rotation encoders **48** (see FIG. **14A**) can be used to track each incremental movement away or toward the initial coordinate positions. This enables the control computer **90** to track the positions of the ultrasonic transducer arrays **88** carried by the crawler vehicles **20c** and **20d** during ultrasonic inspection.

In accordance with an alternative embodiment, a cart having a multiplicity of vacuum adherence devices and a multiplicity of ball-and-socket bearings (such as the ball-and-socket bearings disclosed in U.S. Patent Nos. **9,302,787** and **9,950,813** assigned to the assignee of the instant patent application) may be substituted for the holonomic-motion crawler vehicle **18a** depicted in FIG. **16**. In the alternative, rollers, casters or omni wheels could be employed.

FIG. **18A** is a block diagram identifying some components of a gravity-compensating system that includes a cart **19** having a cable spool **52** that is torqued by a constant-force tensioning spring **86**. One end of cable **22** is attached to the cable spool **52**; the other end of cable **22** is attached to the frame **2** of a crawler vehicle **20**. In this example, the tensioning spring **86** generates a tensile force in the cable **22** to counteract a gravitational force being exerted on the crawler vehicle **20** as it moves.

FIG. **18B** is a block diagram identifying some components of a gravity-compensating system that includes a cart **19** having a cable spool **52** that is torqued by a spool motor **54**. One end of cable **22** is attached to the cable spool **52**; the other end of cable **22** is attached to the frame **2** of a crawler vehicle **20**. In this example, the spool motor **54** is activated by the motor controller **85** to rotate in accordance with commands from a computer system **110** onboard the cart **19**. The computer system **110** in turn receives operational instructions from a ground-based control computer via a transceiver **80** mounted to the cart **19**. The controlled rotation of the spool motor **54** generates a tensile force in the cable **22** to counteract a gravitational force being exerted on the crawler vehicle **20** as it moves.

FIGS. **19A** and **19B** are diagrams representing front end views of an aircraft fuselage **100** at two different instants in time during an automated maintenance procedure performed using a gravity-compensating system in

accordance with a fourth embodiment. The gravity-compensating system that includes an anchor device **74** attached to the external surface **112** and a tool-equipped crawler vehicle **20** vacuum adhered to the external surface **112**. One end of cable **22** is attached to the cable spool **52**; the other end of cable **22** is attached to the frame **2** of the crawler vehicle **20**. The length of paid-out cable **22** shown in FIG. **19B** is greater than the length of paid-out cable **22** shown in FIG. **19A**. In this example, the cable spool **52** is rotated (by a tensioning spring or a spool motor) to generate a tensile force in the cable **22** to counteract a gravitational force being exerted on the crawler vehicle **20** as it moves. The anchor device **74** may be lowered into place by a crane (not shown in the drawings) that has an end effector which grips a handle **76** which is attached to the anchor base **75**. The anchor base **75** may be attached to the external surface **112** using the same type of high-force static surface attachment device **77** as is depicted in FIGS. **20A** and **20B**, such as suction cups or an electro-adhesive gripper.

FIGS. **20A** and **20B** are diagrams representing front end views of an aircraft fuselage at two different instants in time during an automated maintenance procedure performed using a gravity-compensating system in accordance with a fifth embodiment. The gravity-compensating system includes a spool-equipped crawler vehicle **18b** attached to the external surface **112** and a tool-equipped crawler vehicle **20** vacuum adhered to the external surface **112**. One end of cable **22** is attached to the cable spool **52**; the other end of cable **22** is attached to the frame **2** of the crawler vehicle **20**. The length of paid-out cable **22** shown in FIG. **20B** is greater than the length of paid-out cable **22** shown in FIG. **20A**. The crawler vehicle **18b** may be driven to a desired location and then attached to the external surface **112** using a high-force static surface attachment device **77**, such as suction cups or an electro-adhesive gripper. Then the crawler vehicle **20** may be driven along a scan path. The cable spool **52** rotatably mounted to the frame **2** of the crawler vehicle **18b** is rotated (by a tensioning spring or a spool motor) to

generate a tensile force in the cable **22** to counteract a gravitational force being exerted on the crawler vehicle **20** as it scans an area on the external surface **112**.

FIG. **21** is a diagram representing a front end view of an aircraft fuselage **100** at an instant in time during an automated maintenance procedure performed using a gravity-compensating system in accordance with a sixth embodiment. The gravity-compensating system includes a ground vehicle **78** equipped with a cable spool **52b**, a crawler vehicle **18a** equipped with a cable spool **52a** and connected to the ground vehicle **78** by an umbilical cable **24**, and a crawler vehicle **20** equipped with a maintenance tool (not shown in FIG. **21**) and connected to crawler vehicle **18a** by a cable **22**. The crawler vehicles **18a** and **20** are both vacuum adhered to the external surface **112** of the aircraft fuselage **100**. The crawler vehicles **18a** and **20** may be configured to move holonomically. One end of umbilical cable **24** is attached to the cable spool **52b**, while the other end of umbilical cable **24** is attached to the frame **2** of the crawler vehicle **18a**; one end of cable **22** is attached to the cable spool **52a**, while the other end of cable **22** is attached to the frame **2** of the crawler vehicle **20**. The cable spool **52a** rotatably mounted to the frame **2** of the crawler vehicle **18b** is rotated (by a tensioning spring or a spool motor) to generate a tensile force in the cable **22** to counteract a gravitational force being exerted on the crawler vehicle **20** as it scans an area on the external surface **112**.

FIG. **22** is a diagram representing a front end view of an aircraft fuselage **100** at an instant in time during an automated maintenance procedure performed using a gravity-compensating system in accordance with a seventh embodiment. The gravity-compensating system includes a ground vehicle **78** equipped with a cable spool **52**, a crawler vehicle **18c** equipped with a pair of pulleys **26a** and **26b**, and a crawler vehicle **20** equipped with a maintenance tool (not shown in FIG. **22**). In this embodiment, the frame **2** of the crawler vehicle **20** is connected to the cable spool **52a** by means of a cable **22** which passes over the pulleys **26a** and **26b**. The crawler vehicles **18c** and **20** are both vacuum adhered to

the external surface **112** of the aircraft fuselage **100**. The crawler vehicles **18c** and **20** and ground vehicle **78** may be configured to move holonomically. The cable spool **52** rotatably mounted to the ground vehicle **78** is rotated (by a tensioning spring or a spool motor) to generate a tensile force in the cable **22** to counteract a gravitational force being exerted on the crawler vehicle **20** as it scans an area on the external surface **112**. During such scanning, the pulleys **26a** and **26b** support the cable **22** at a distance from the external surface **112** so that the cable **22** neither contacts the external surface **112** nor snags on any obstacles protruding therefrom.

Additional embodiments of a gravity-compensating system for use with cable-suspended tool-equipped crawler vehicles will now be disclosed with reference to FIGS. **23** through **26**. The systems respectively depicted in FIGS. **23-26** have some common features. To avoid repetitive description of common features, at least some common features will now be described. Thereafter respective distinctive features of each system will be separately described.

The gravity-compensating systems depicted in FIGS. **23-26** are designed for automated maintenance of a storage tank **106** having a horizontal flat top surface **128** and a vertical side surface **114** that surrounds the volume of space underneath the flat top surface **128** for the purpose of containing solid or liquid matter. The outer periphery of the horizontal flat top surface **128** of the storage tank **106** is circular and the vertical side surface **114** is circular cylindrical. Each of FIGS. **23-26** represents a view of a storage tank **106** at an instant in time during an automated maintenance procedure performed using gravity-compensating system in accordance with various embodiments.

Each of the systems depicted in FIGS. **23-26** includes a cable spool **52** supported by apparatus on the flat top surface **128**, a cable **22** having one end attached to and a portion wrapped around the cable spool **52**, and a crawler vehicle **20** vacuum adhered to the vertical side surface **114** of the storage tank **106**

and attached to the other end of the cable **22**. Preferably the crawler vehicle **20** is configured for holonomic motion. The crawler vehicle **20** includes a maintenance tool (not shown in FIGS. **23-26**) for use in performing a maintenance operation on the vertical side surface **114**. In each of the systems depicted in FIGS. **23-26**, one end of cable **22** is attached to the cable spool **52**, while the other end of cable **22** is attached to the frame **2** of the crawler vehicle **20**. The cable spool **52** is positioned so that it projects radially outward beyond the vertical side surface **114** by a sufficient distance to prevent the paid-out portion of the cable **22** from contacting the vertical side surface **114**.

In each of the situations depicted in FIGS. **23-26**, the crawler vehicle **20** may be moved horizontally along the vertical side surface **114** during a scanning operation. For example, if crawler vehicle **20** were carrying an ultrasonic transducer array, then a stripe-shaped area of the vertical side surface **114** may be ultrasonically inspected along a scan path that is generally horizontal. As the crawler vehicle **20** moves sideways along the horizontal scan path, the crawler vehicle **20** circumnavigates the vertical side surface **114**. The cable spool **52** rotates around a center of the horizontal flat top surface **128** as the crawler vehicle **20** circumnavigates the vertical side surface **114**. In addition, the cable spool **52** is rotated (by a tensioning spring or a spool motor) to generate a tensile force in the cable **22** to counteract a gravitational force being exerted on the crawler vehicle **20** as the ultrasonic transducer array scans an area on the vertical side surface **114**.

The only differences amongst the various embodiments depicted in FIGS. **23-26** are found in the respective components that support the cable spool **52**. Those differences will now be described separately for each embodiment.

In the eighth embodiment depicted in FIG. **23**, the components supporting the cable spool **52** include a lifting carriage **21** that rides on a circular track **126** placed on the horizontal flat top surface **128** of the storage tank **106**. The circular track **126** is concentric with the circular outer periphery of the horizontal flat

top surface **128**. The cable spool **52** is rotatably mounted to a frame **23** of the lifting carriage **21**. As the crawler vehicle **20** circumnavigates the vertical side surface **114** at a constant elevation, the lifting carriage **21** travels along the circular track **126** at the same angular speed, trying to maintain the cable **22** in a vertical position during scanning.

FIG. **24** is a diagram representing a view of a storage tank **106** at an instant in time during an automated maintenance procedure performed using a gravity-compensating system in accordance with a ninth embodiment. The gravity-compensating system includes a crawler vehicle **20a** that is vacuum adhered to the horizontal flat top surface **128** of the storage tank **106** and a cable-suspended crawler vehicle **20b** that is vacuum adhered to a vertical side surface **114** of the storage tank **106**. Preferably the crawler vehicles **20a** and **20b** are configured for holonomic motion. The crawler vehicle **20a** includes a frame **2** and a cable spool **52** rotatably mounted to the frame **2**, while the crawler vehicle **20b** includes a maintenance tool (not shown in FIG. **24**) for use in performing a maintenance operation on the vertical side surface **114**. One end of cable **22** is attached to the cable spool **52** on the crawler vehicle **20a**, while the other end of cable **22** is attached to the frame **2** of the crawler vehicle **20b**.

In the situation depicted in FIG. **24**, the crawler vehicle **20b** may be moved horizontally along the vertical side surface **114** during a scanning operation. As the crawler vehicle **20b** moves sideways along a horizontal scan path, the crawler vehicle **20a** rotates and translates in a manner that seeks to maintain the cable **22** in a vertical position during scanning. In effect, the crawler vehicle **20a** rotates around a center of the horizontal flat top surface **128** at the same angular speed as the angular speed at which the crawler vehicle **20b** circumnavigates the vertical side surface **114**.

FIG. **25** is a diagram representing a view of a storage tank **106** at an instant in time during an automated maintenance procedure performed using a

gravity-compensating system in accordance with a tenth embodiment. The gravity-compensating system includes a passive anchor device **25** attached at a central position on the horizontal flat top surface **128** and a tool-equipped crawler vehicle **20** vacuum adhered to the vertical side surface **114**. Preferably the crawler vehicle **20** is configured for holonomic motion. The anchor device **25** includes an anchor base (not shown in FIG. **25**, but see anchor base **75a** in FIG. **27**) that may be attached to the flat top surface **128** using suction cups or an electro-adhesive gripper. The anchor device **25** further includes a turret **124** that is rotatably coupled to the anchor base **75a**, a pivot arm **98** having a proximal end connected to and extending radially outward from the turret **124**, and a cable spool **52** rotatably mounted to a distal end of the pivot arm **98**. The axis of rotation of the cable spool **52** may be perpendicular to the axis of rotation of the turret **124**.

In the situation depicted in FIG. **25**, as the crawler vehicle **20** circumnavigates the vertical side surface **114**, the cable **22** pulls the cable spool **52** in a circumferential direction that causes the turret **124** and pivot arm **98** to follow the crawler vehicle **20**. In effect, the pivot arm **98** rotates around a center of the horizontal flat top surface **128** at the same angular speed as the angular speed of the crawler vehicle **20**, but with a slight lag due to a small angle by which the cable **22** deviates from a true vertical position.

FIG. **26** is a diagram representing a view of a storage tank **106** at an instant in time during an automated maintenance procedure performed using a gravity-compensating system in accordance with an eleventh embodiment. The gravity-compensating system includes a motorized anchor device **25a** attached at a central position on the horizontal flat top surface **128** and a tool-equipped crawler vehicle **20** vacuum adhered to the vertical side surface **114**. The motorized anchor device **25a** includes an anchor base **75a** (see FIG. **27**) as previously described. The motorized anchor device **25a** further includes a turret **124** that is rotatably coupled to the anchor base **75a**, a pivot arm **98** extending radially outward from the turret **124**, a cable spool **52** rotatably mounted to a distal end of the pivot arm **98**,

and an arm rotation motor **118**. In the situation depicted in FIG. **26**, the arm rotation motor **118** is activated to cause the turret **124** and pivot arm **98** to follow and rotate at the same angular speed as the angular speed at which the crawler vehicle **20** is circumnavigating the vertical side surface **114**.

5 FIG. **27** is a block diagram identifying some of the components of the anchor device **25a** depicted in FIG. **26**. As previously mentioned, the anchor device **25a** further includes an anchor base **75a**, a turret **124** rotatably coupled to the anchor base **75a** by means of a bearing **122**, a pivot arm **98** extending radially outward from the turret **124**, and a cable spool **52** rotatably mounted to a distal end
10 of the pivot arm **98**. The anchor device **25a** further includes an arm rotation motor **118** mechanically coupled to the turret **124** by means of a gearing system **120**. The arm rotation motor **118** operates under the control of one motor controller **85**. The motor controller **85** in turn receives commands from a computer system **110** which may be incorporated in the anchor device **25a**. The computer system **110** is also
15 configured to control operation of the spool motor **54** (not shown in FIG. **27**). The anchor device **25a** further includes a transceiver **80** for receiving operational instructions from a ground-based control computer (not shown in FIG. **27**).

In accordance with one proposed implementation, the cable spool **52** is rotatably coupled to the distal end of the pivot arm **98** by means of a second
20 turret similar to turret **46** depicted in FIG. **4**. More specifically, the spool axle **50** (see FIG. **14A**) about which the cable spool **52** rotates is freely rotatable about an axis of the pivot arm **98**. When the cable spool **52** is located directly over the crawler vehicle **20**, the angle of the spool axle **50** is perpendicular to a vertical plane, meaning that the cable spool **52** is oriented vertically at an angle of 0°
25 relative to a vertical plane. As the crawler vehicle **20** moves horizontally along the vertical side surface **114** and the pivot arm **98** is not rotating, however, the angle of the cable spool **52** will deviate from 0° relative to a vertical plane. The anchor device **25a** further includes an angle sensor **130** (e.g., a rotation encoder) that detects this deviation from the 0° angular position. The output of the angle sensor

130 is output to the computer system 110, which then controls arm rotation motor 118 in a manner that seeks to restore the 0° angular position of the cable spool 52, in which situation the paid-out portion of the cable 22 would be vertical. In this manner, the pivot arm 98 may be controlled to rotate in a manner so that the cable spool 52 maintains a position directly above the circumnavigating crawler vehicle 20. In addition, the cable spool 52 is rotated (by a tensioning spring or a spool motor not shown in FIG. 27) to generate a tensile force in the cable 22 to counteract a gravitational force being exerted on the crawler vehicle 20 as the ultrasonic transducer array 88 (see FIG. 17) scans an area on the vertical side surface 114.

In each of the embodiments depicted in FIGS. 23-26, the length of the paid-portion of the cable 22 can be measured using another rotation encoder that is operatively coupled to the cable spool 52. This rotation encoder measures the angle of rotation of the cable spool 52 about the spool axle 50. Assuming that the elevation of the axis of rotation of the cable spool 52 about the spool axle 50 has been measured during initial setup of the system, the rotation encoder output will represent the length of the paid-portion of the cable 22, which in turn indicates the elevation of the point where the cable is attached to the frame 2 of the crawler vehicle 20. Because the geometry and dimensions of the crawler vehicle 20 are known, the computer system 110 may be configured to calculate the vertical position of the ultrasonic transducer array 88 in the frame of reference of the storage tank 106 based on the initial coordinates of the cable spool 52, the measured length of the paid-portion of the cable 22, and the known position of the ultrasonic transducer array 88 relative to the point of cable attachment.

Each of the lifting carriage 21 (depicted in FIG. 23), passive anchor device 25 (depicted in FIG. 25), and motorized anchor device 25a (depicted in FIG. 26) can utilize vacuum, electrostatic clamping, magnetic clamping, attachment to another structure, or even its own weight, to maintain positioning during operation. In addition, the lifting carriage, passive anchor device 25 or motorized anchor

device **25a** may be lifted into position on the horizontal flat top surface **128** of the storage tank **106** by means of an unmanned aerial vehicle, crane or crawler or by manual means.

5 The automated apparatus disclosed herein can be adapted for use in the automation of various maintenance functions, including but not limited to non-destructive inspection, drilling, grinding, fastening, applique application, scarfing, ply mapping, marking, cleaning and painting. In cases where the end effector is a rotary tool (such as a scarfer, drill, deburrer or reamer), when the rotary tool reaches a target position, the computer system can be programmed to activate the
10 end effector motor (not shown in drawings) via a motor controller to drive rotation of the rotary tool.

15 While apparatus and methods for providing gravity compensation for cable-suspended, vacuum-adhered, tool-equipped crawler vehicles moving on non-level surfaces have been described with reference to particular embodiments, it will be understood by those skilled in the art that various changes may be made and equivalents may be substituted for elements thereof without departing from the scope of the teachings herein. In addition, many modifications may be made to adapt a particular situation to the teachings herein without departing from the essential scope thereof. Therefore it is intended that the claims set forth hereinafter
20 not be limited to the disclosed embodiments.

25 As used herein, the term "computer system" should be construed broadly to encompass a system having at least one computer or processor, and which may have multiple computers or processors that communicate through a network or bus. As used in the preceding sentence, the terms "computer" and "processor" both refer to devices comprising a processing unit (e.g., a central processing unit) and some form of memory (i.e., computer-readable medium) for storing a program which is readable by the processing unit.

The methods described herein may be encoded as executable instructions embodied in a non-transitory tangible computer-readable storage medium, including, without limitation, a storage device and/or a memory device. Such instructions, when executed by a processor or computer, cause the processor or computer to perform at least a portion of the methods described herein.

The method claims set forth hereinafter should not be construed to require that the steps recited therein be performed in alphabetical order (any alphabetical ordering in the claims is used solely for the purpose of referencing previously recited steps) or in the order in which they are recited unless the claim language explicitly specifies or states conditions indicating a particular order in which some or all of those steps are performed. Nor should the method claims be construed to exclude any portions of two or more steps being performed concurrently or alternately unless the claim language explicitly states a condition that precludes such an interpretation.

EMBODIMENTS IN WHICH AN EXCLUSIVE PROPERTY OR PRIVILEGE IS CLAIMED ARE DEFINED AS FOLLOWS:

1. A method for compensating for gravity during movement of a crawler vehicle on a surface of a body, the method comprising:

(a) attaching one end of a first cable to a first crawler vehicle;

(b) attaching another end of the first cable to a first spool of a second crawler vehicle;

(c) placing the first crawler vehicle at a first position in contact with a first surface area on the surface of the body, wherein the first surface area is non-level;

(d) placing the second crawler vehicle at a second position in contact with a second surface area on the surface of the body;

(e) adhering the first crawler vehicle to the surface of the body using suction;

(f) while the first crawler vehicle is adhered to the surface, moving the first crawler vehicle along a first path that extends from the first position to a third position in contact with a third surface area on the surface of the body; and

(g) tensioning the first cable to exert a tensile force on the first crawler vehicle having a vector component in opposition to a force of gravity tending to urge the first crawler vehicle to a lower elevation during step (f).

2. The method as recited in claim 1, further comprising operating a first maintenance tool of the first crawler vehicle to perform a maintenance operation on the surface at a point along the first path.

- 5
3. The method as recited in claim 1, further comprising attaching the second crawler vehicle to the surface at the second position by producing an attachment force having a magnitude sufficient to prevent detachment of the second crawler vehicle even when supporting an entire weight of the first crawler vehicle.
4. The method as recited in claim 3, wherein the attachment force is produced by one of the following forces: suction, electrostatic adhesion or magnetic attraction.
5. The method as recited in claim 1, further comprising:
- 10 moving the second crawler vehicle along a second path while the first crawler vehicle is moving along the first path; and
- operating a second maintenance tool of the second crawler vehicle to perform a maintenance operation on the surface at a point along the second path.
- 15 6. The method as recited in claim 1, wherein step (g) comprises winding a portion of the first cable on the first spool.
7. The method as recited in claim 6, wherein rotation of the first spool in a winding direction is motor-driven or spring-driven.
8. The method as recited in claim 1, further comprising:
- 20 (h) attaching one end of a second cable to a third crawler vehicle;
- (i) attaching another end of the second cable to a second spool of the second crawler vehicle;

(j) placing the third crawler vehicle at a fourth position in contact with a fourth surface area on the surface of the body, wherein the fourth surface area is non-level;

5 (k) adhering the third crawler vehicle to the surface of the body using suction;

(l) while the third crawler vehicle is adhered to the surface, moving the third crawler vehicle along a second path that extends from the fourth position to a fifth position in contact with a fifth surface area on the surface of the body; and

10 (m) tensioning the second cable to exert a tensile force on the third crawler vehicle having a vector component in opposition to a force of gravity tending to urge the third crawler vehicle to a lower elevation during step (l).

9. The method as recited in claim 8, further comprising:

15 operating a first maintenance tool of the first crawler vehicle to perform a maintenance operation on the surface at a point along the first path; and

20 operating a second maintenance tool of the second crawler vehicle to perform a maintenance operation on the surface at a point along the second path.

10. The method as recited in claim 1, further comprising:

attaching one end of a second cable to a second spool of a ground vehicle;

25 attaching another end of the second cable to the second crawler vehicle; and

placing the ground vehicle in contact with a ground in proximity to the body,

wherein step (g) comprises winding a portion of the second cable on the second spool.

5 **11.** The method as recited in claim 1, wherein the body is an aircraft fuselage.

12. A method for performing a maintenance operation on a body having a top surface and a non-level side surface that extends downward to elevations lower than a lowest elevation of the top surface, the method comprising:

10 (a) attaching one end of a cable to a crawler vehicle that is carrying a maintenance tool;

 (b) attaching another end of the cable to a spool of an anchor device;

 (c) placing the anchor device in contact with the top surface of the body;

15 (d) attaching the anchor device to the top surface with an attachment force having a magnitude sufficient to prevent detachment of the anchor device by producing an attachment force having a magnitude sufficient to prevent detachment of the crawler vehicle even when supporting an entire weight of the crawler vehicle;

 (e) placing the crawler vehicle in contact with the non-level side surface of the body;

20 (f) adhering the crawler vehicle to the non-level side surface using suction;

 (g) moving the crawler vehicle along a path while the crawler vehicle is adhered to the non-level side surface;

(h) tensioning the cable to exert a tensile force on the crawler vehicle having a vector component in opposition to a force of gravity tending to urge the crawler vehicle to a lower elevation during step (g); and

(i) operating the maintenance tool to perform a maintenance operation on the non-level side surface at a point along the path.

5

13. The method as recited in claim **12**, wherein the attachment force is produced by one of the following forces: suction, electrostatic adhesion or magnetic attraction.

10

14. The method as recited in claim **12**, wherein step (h) comprises winding a portion of the cable on the spool.

15. The method as recited in claim **12**, wherein a portion of the cable between the crawler vehicle and spool does not contact the body while the anchor device is attached to the top surface and the crawler vehicle is in contact with the non-level side surface.

15

16. The method as recited in claim **15**, wherein the top surface has a circular outer periphery, further comprising:

rotatably coupling a spool to a distal end of a rotatable arm;

placing a proximal end of the rotatable arm on the top surface of the body so that a center of rotation of the rotatable arm is aligned with a center of the circular outer periphery; and

20

rotating the rotatable arm, wherein the rotatable arm has a length that enables a portion of the spool to extend beyond the circular outer periphery of the top surface during rotation of the rotatable arm about the center of rotation.

17. An apparatus comprising first and second crawler vehicles, a cable having one end connected to the first crawler vehicle and another end connected to the second crawler vehicle,

5 wherein the first crawler vehicle comprises: a first frame coupled to the one end of the cable; at least one vacuum adherence device attached to or integrated with the first frame; a first set of wheels rotatably coupled to the first frame; a first drive motor operatively coupled to drive rotation of at least one of the first set of wheels; a first maintenance tool coupled to the first frame and configured for performing a maintenance operation; and a first computer system
10 configured to control operation of the first drive motor and the first maintenance tool, and

15 wherein the second crawler vehicle comprises: a second frame; at least one vacuum adherence device attached to or integrated with the second frame; a second set of wheels rotatably coupled to the second frame; a second drive motor operatively coupled to drive rotation of at least one of the second set of wheels; a cable spool to which the other end of the cable is attached; a spool motor mounted to the second frame and operatively coupled to drive rotation of the cable
20 spool; and a second computer system configured to control operation of the second drive motor and the spool motor.

18. The apparatus as recited in claim 17, further comprising a control computer configured to generate control signals to be sent to the second computer system for selectively activating the spool motor to rotate the cable spool in a
25 direction that winds the cable until a desired tensile force is exerted on the first crawler vehicle.

19. The apparatus as recited in claim 17, wherein the first and second crawler vehicles are configured for holonomic motion.

5
20. The apparatus as recited in claim 17, wherein the second crawler vehicle further comprises a second maintenance tool coupled to the second frame and configured for performing a maintenance operation, and the second computer system is further configured to control operation of the second maintenance tool.

10
21. The apparatus as recited in claim 17, wherein the first crawler vehicle comprises a first arm pivotably coupled to the first frame, the one end of the cable being coupled to the first arm, and the second crawler vehicle comprises a second arm pivotably coupled to the second frame, the cable spool being rotatably coupled to the second arm.

22. An apparatus comprising an anchor device, a crawler vehicle and a cable having one end connected to the anchor device and another end connected to the crawler vehicle,

15
wherein the anchor device comprises: an anchor base; at least one attachment device coupled to the anchor base for attaching the anchor device to a surface; a cable spool to which the one end of the cable is attached; a spool motor operatively coupled to drive rotation of the cable spool; and a first computer system configured to control operation of the spool motor, and

20
wherein the crawler vehicle comprises: a frame; at least one vacuum adherence device attached to or integrated with the frame; a set of wheels rotatably coupled to the frame; a drive motor operatively coupled to drive rotation of at least one wheel of the set of wheels; a maintenance tool coupled to the frame and configured for performing
25
a maintenance operation; and a second computer system configured to control operation of the drive motor and the maintenance tool.

23. The apparatus as recited in claim **22**, further comprising a control computer configured to generate control signals for selectively activating the spool motor to rotate the cable spool in a direction that winds the cable until a desired tensile force is exerted on the crawler vehicle.

5 **24.** The apparatus as recited in claim **22**, wherein the anchor device further comprises:

a turret which is rotatably coupled to the anchor base; and

an arm having a proximal end connected to or integrally formed with the turret and a distal end to which the cable spool is rotatably coupled.

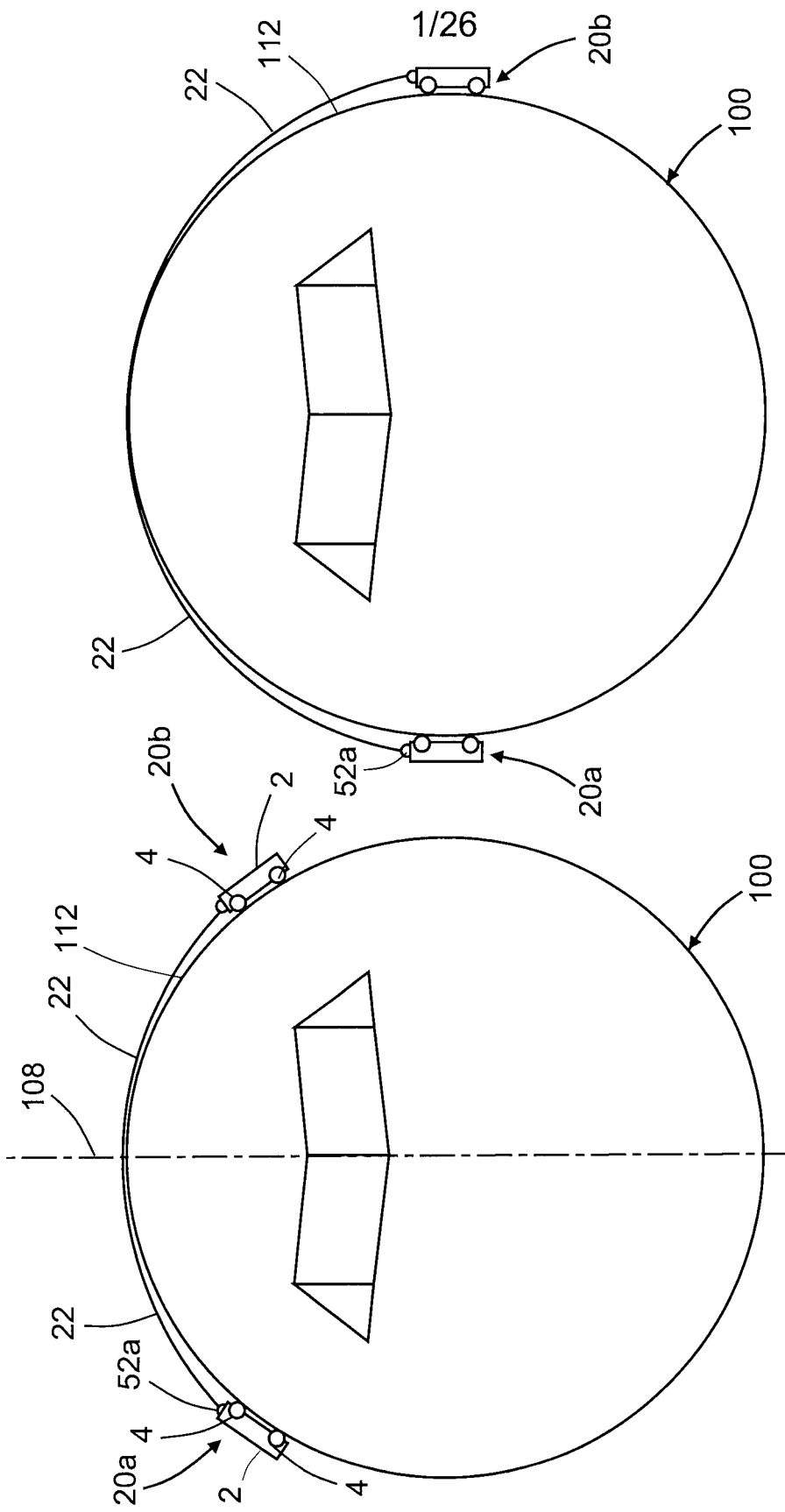

FIG. 1B

FIG. 1A

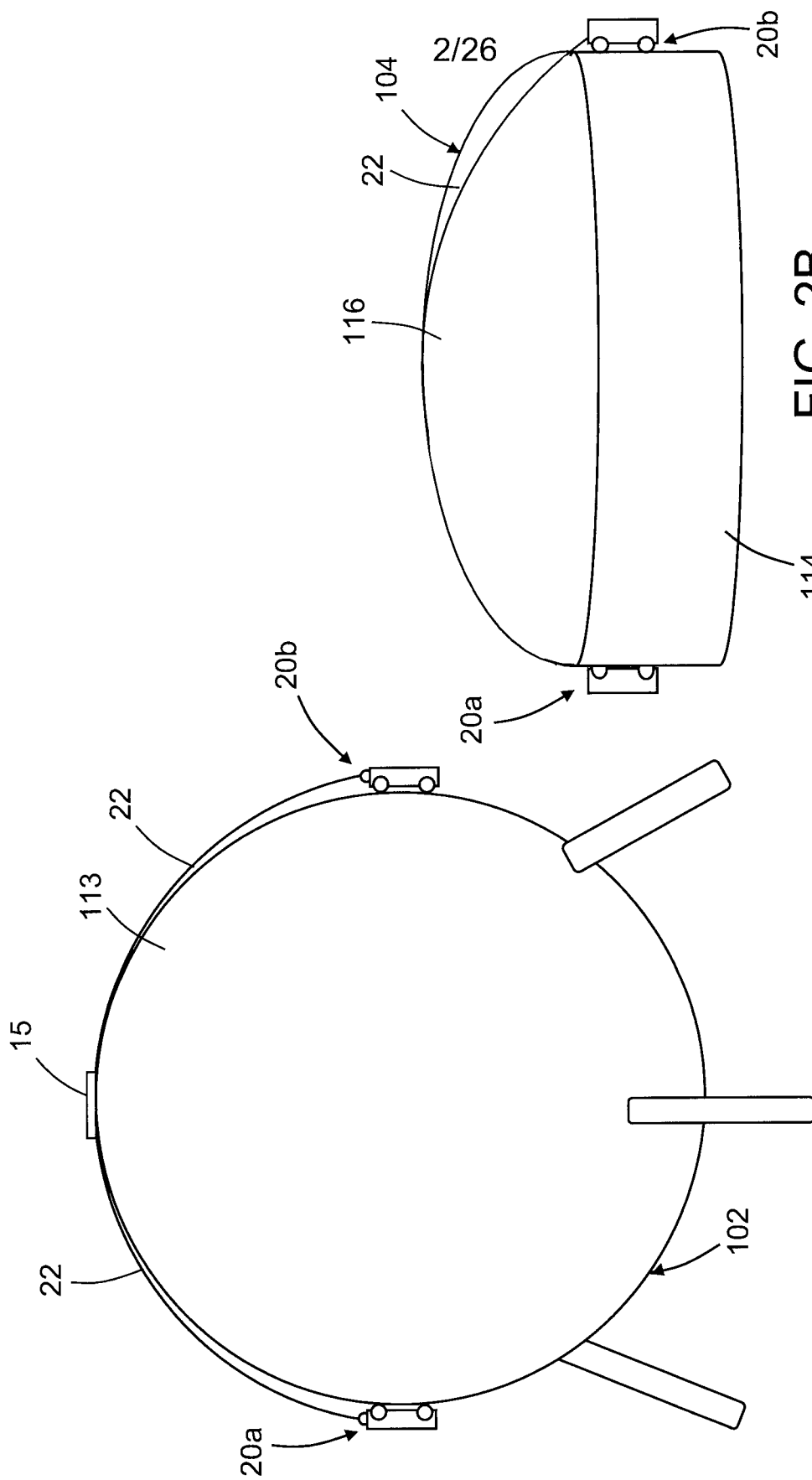

FIG. 2B

FIG. 2A

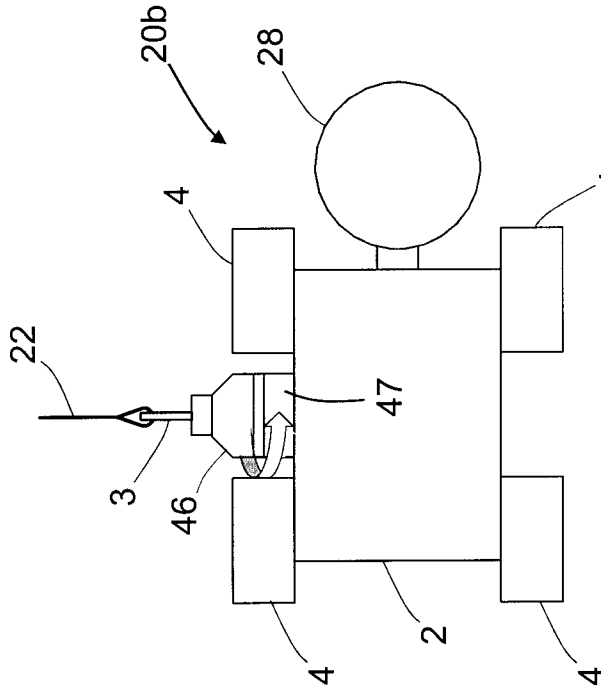

FIG. 3A

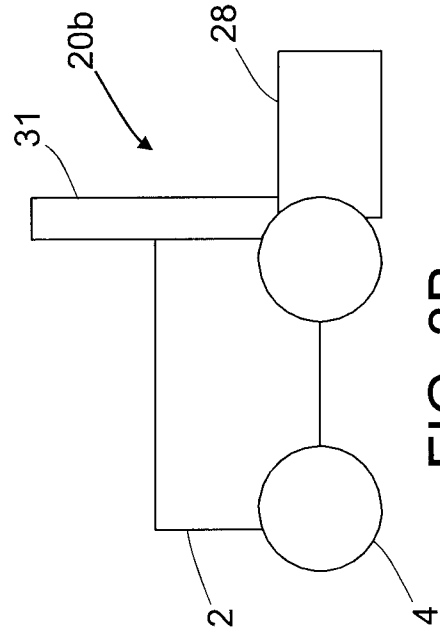

FIG. 3B

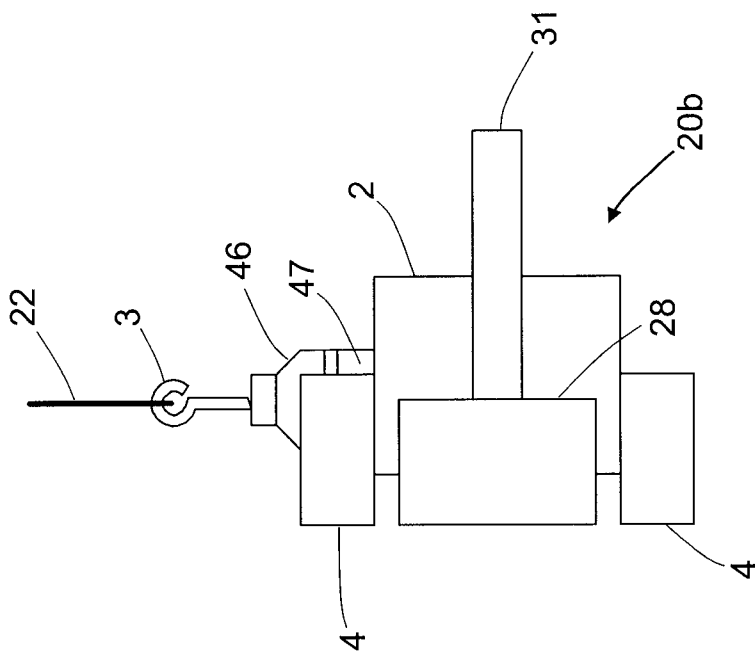

FIG. 3C

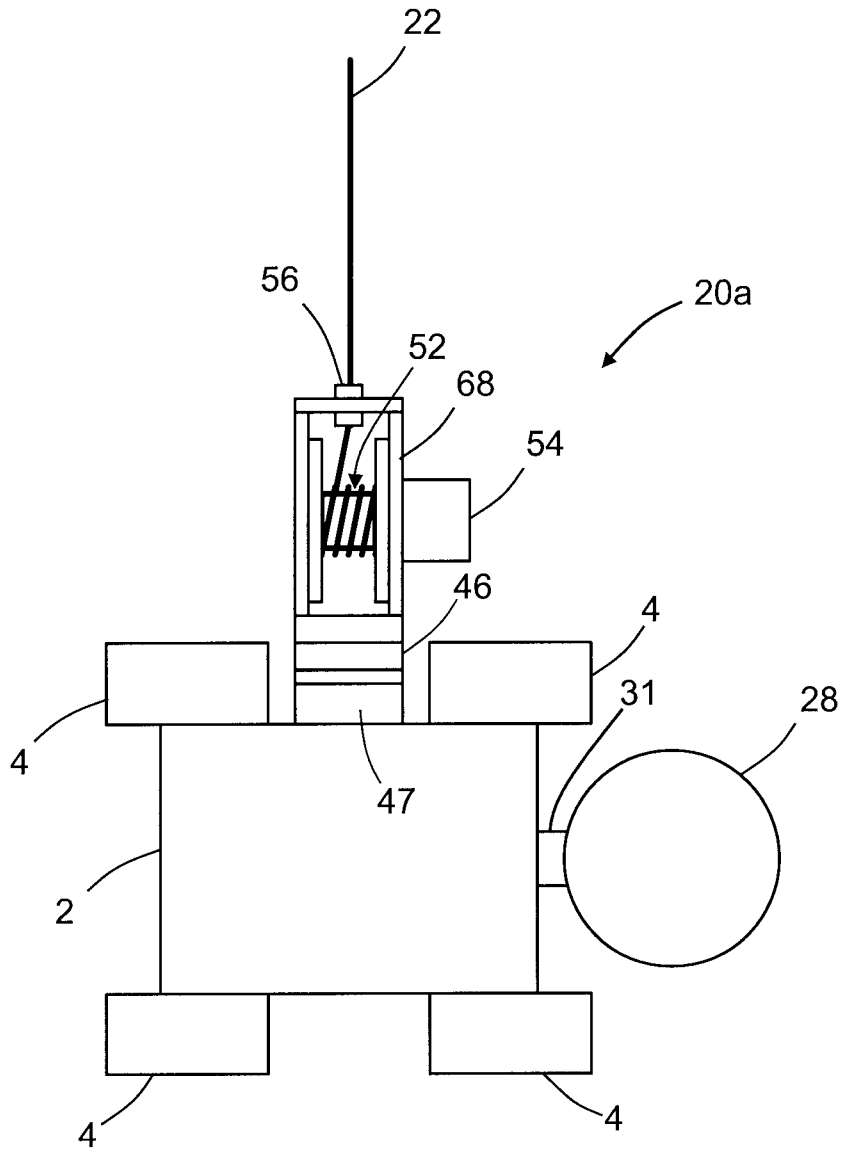

FIG. 4

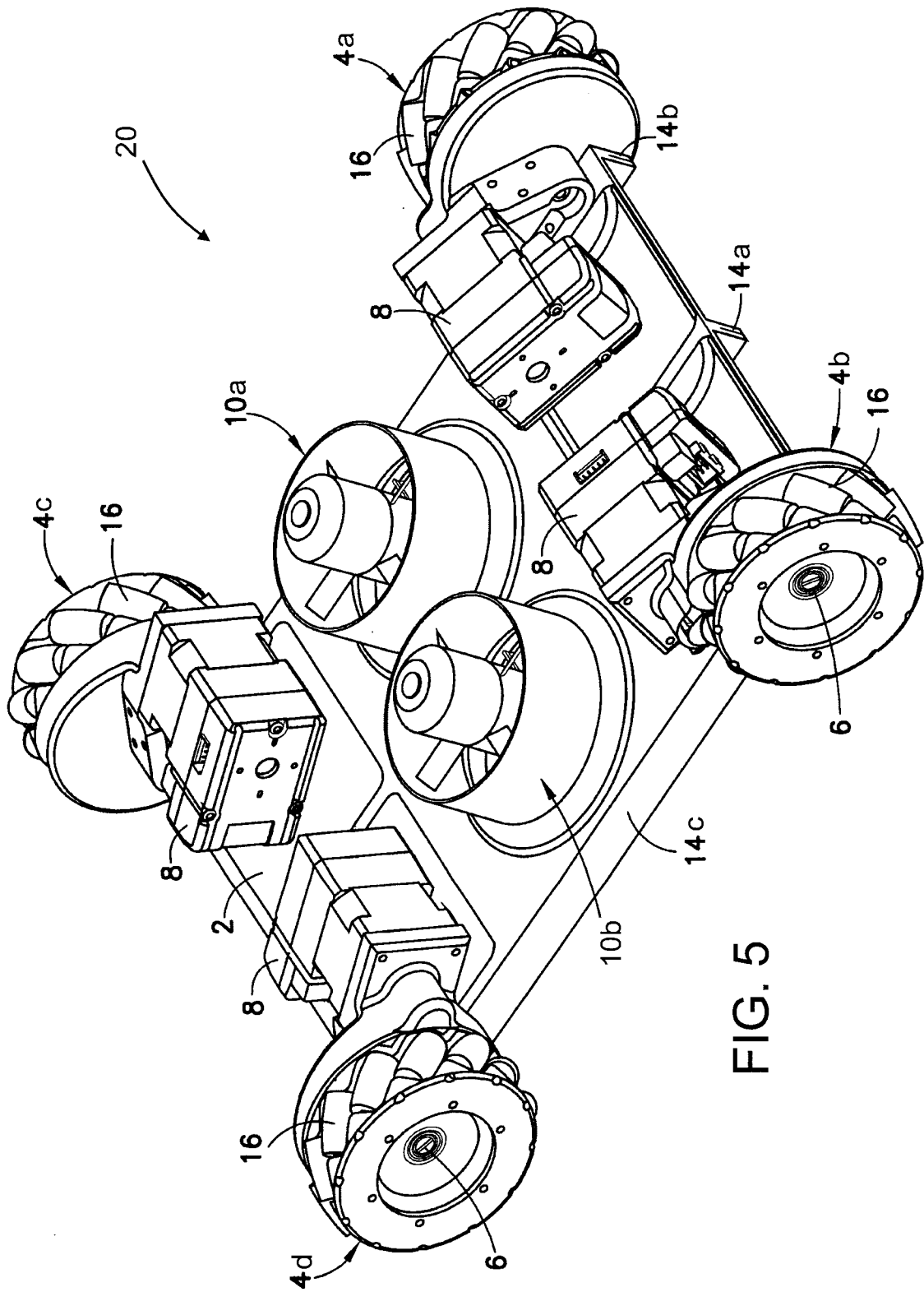

FIG. 5

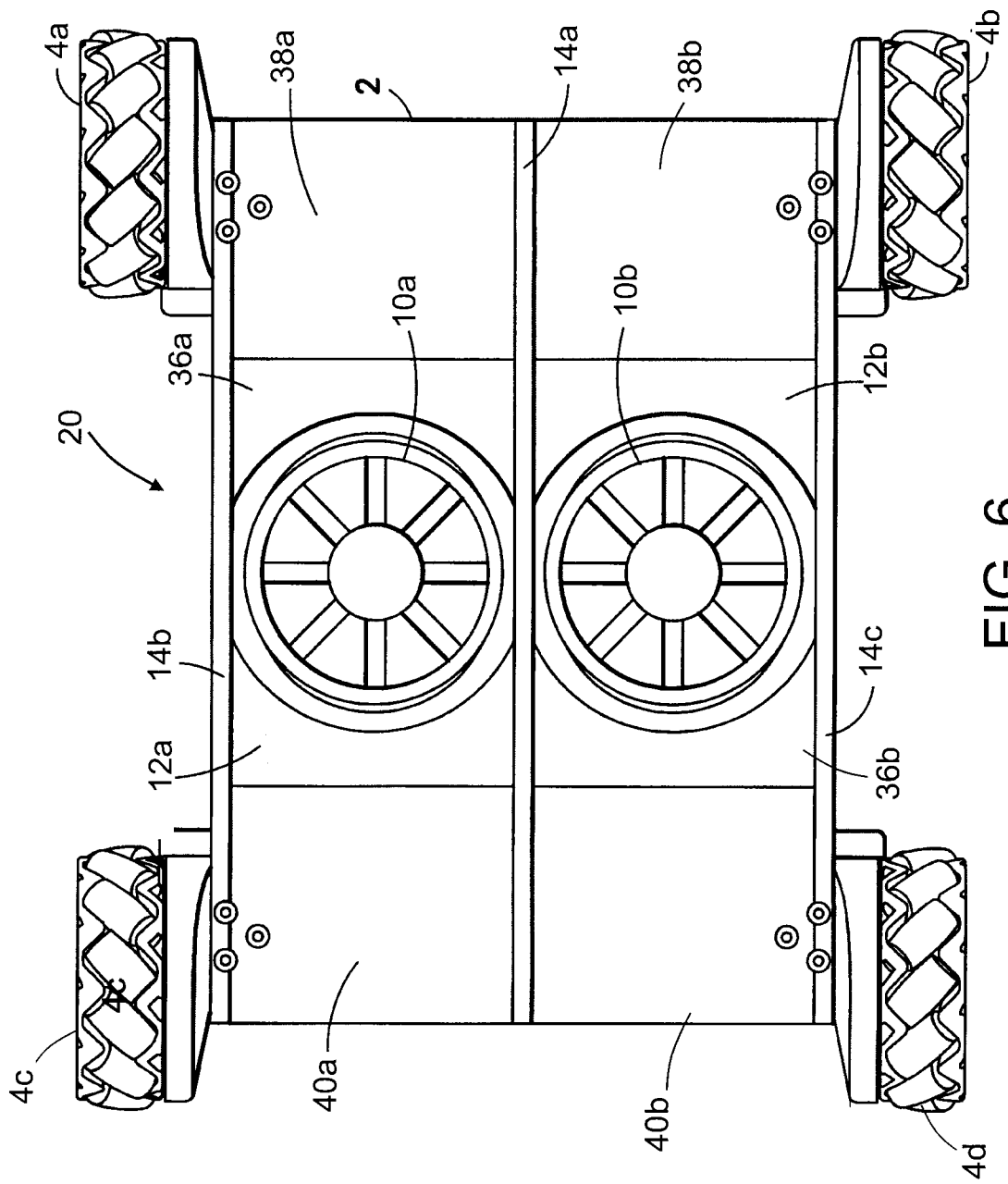

FIG. 6

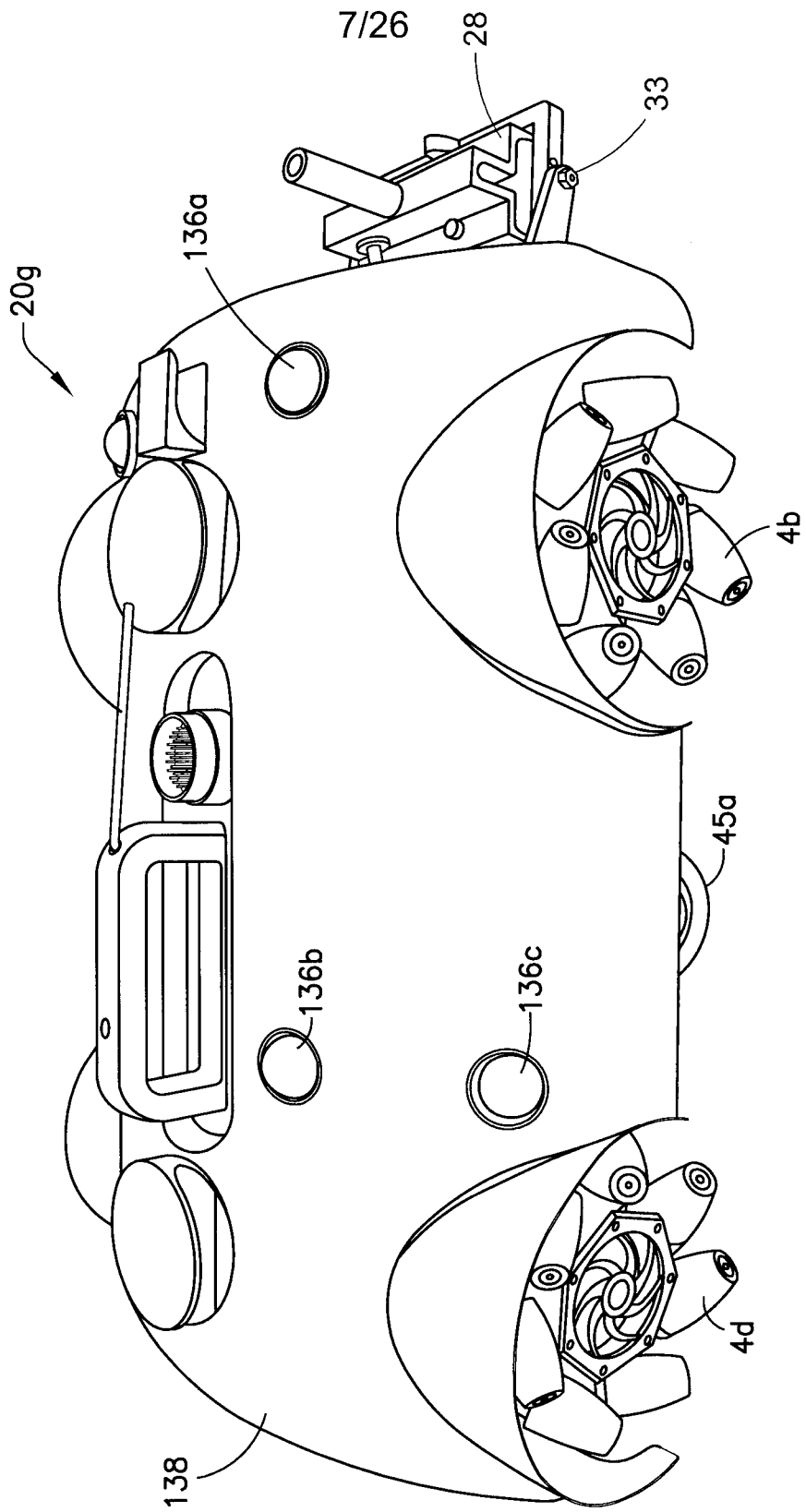

FIG. 7A

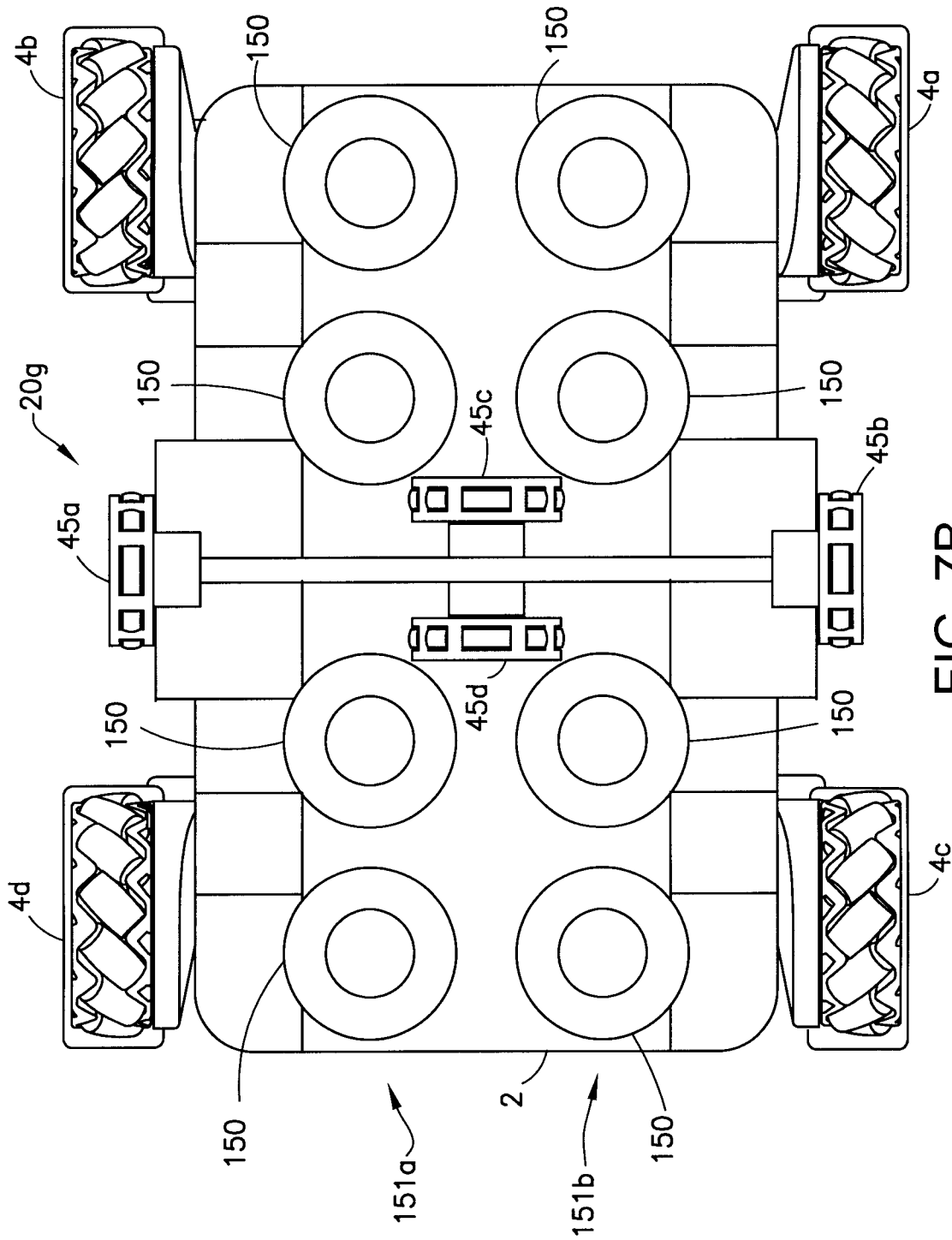

FIG. 7B

9/26

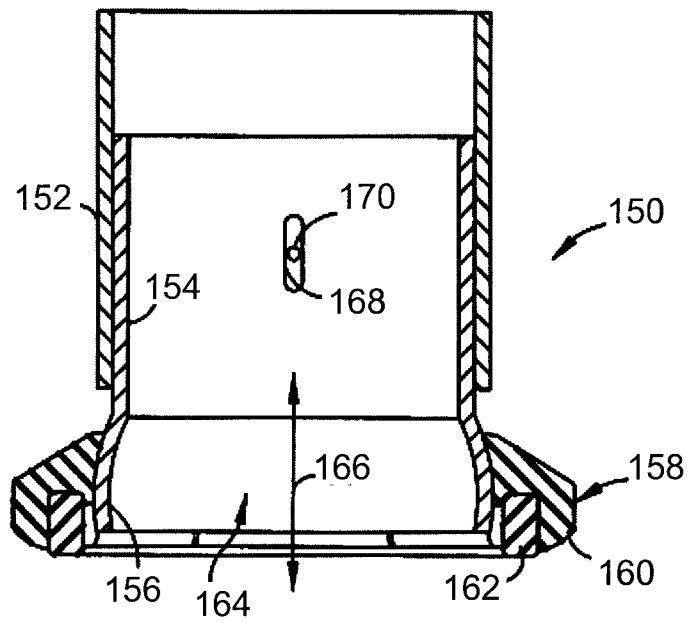

FIG. 8A

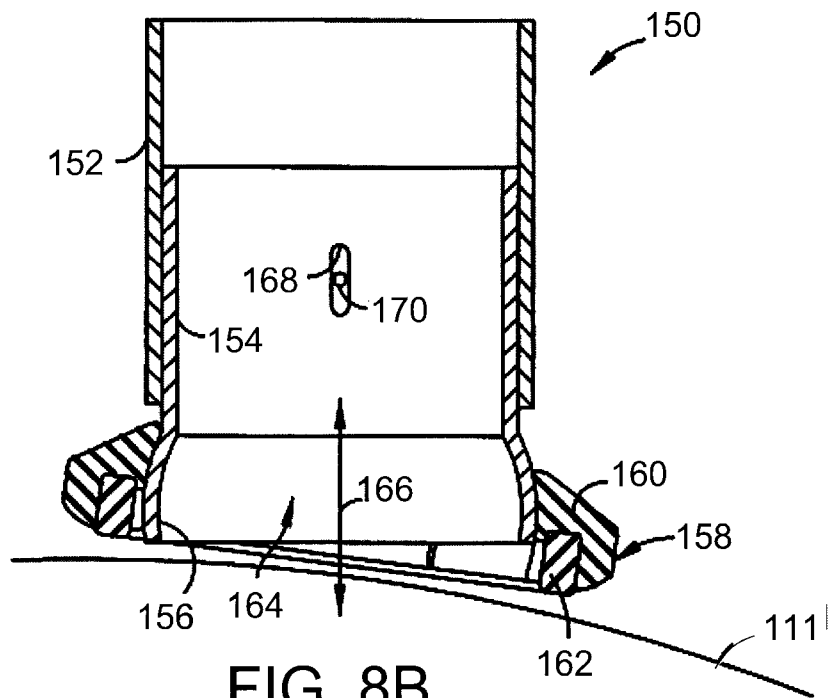

FIG. 8B

10/26

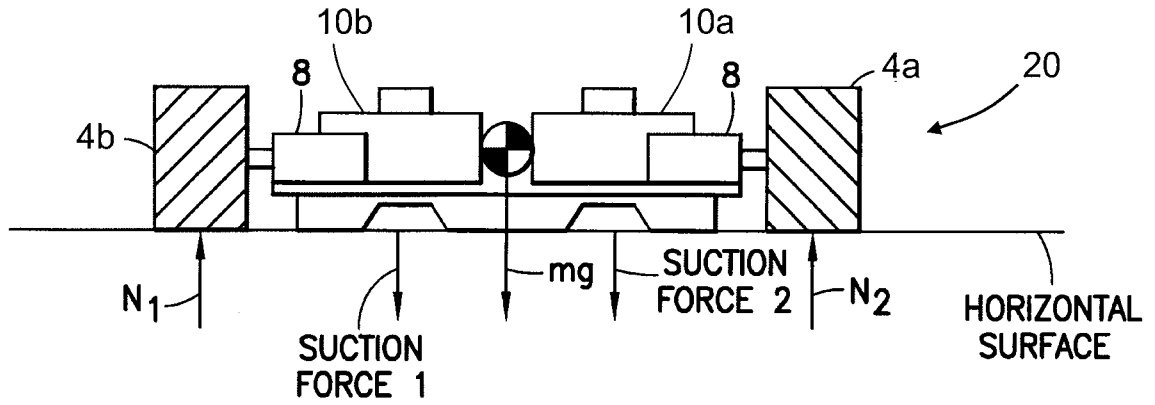

FIG. 9

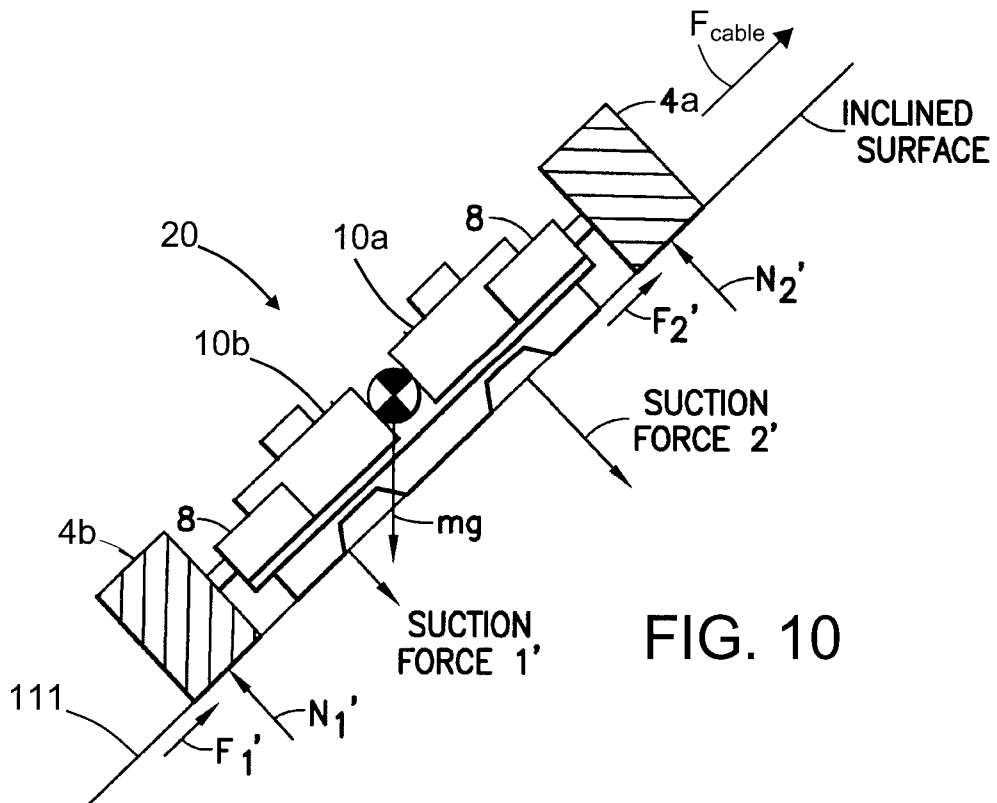

FIG. 10

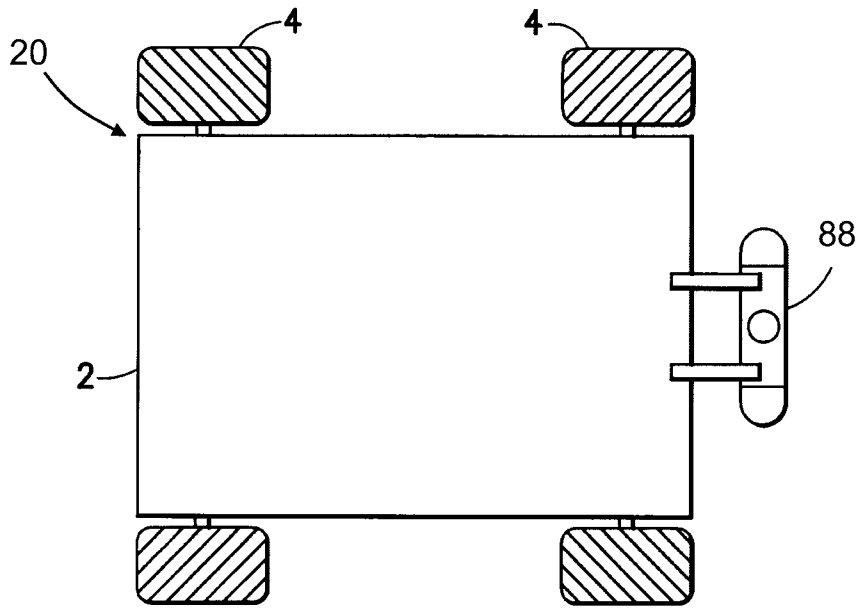

FIG. 11A

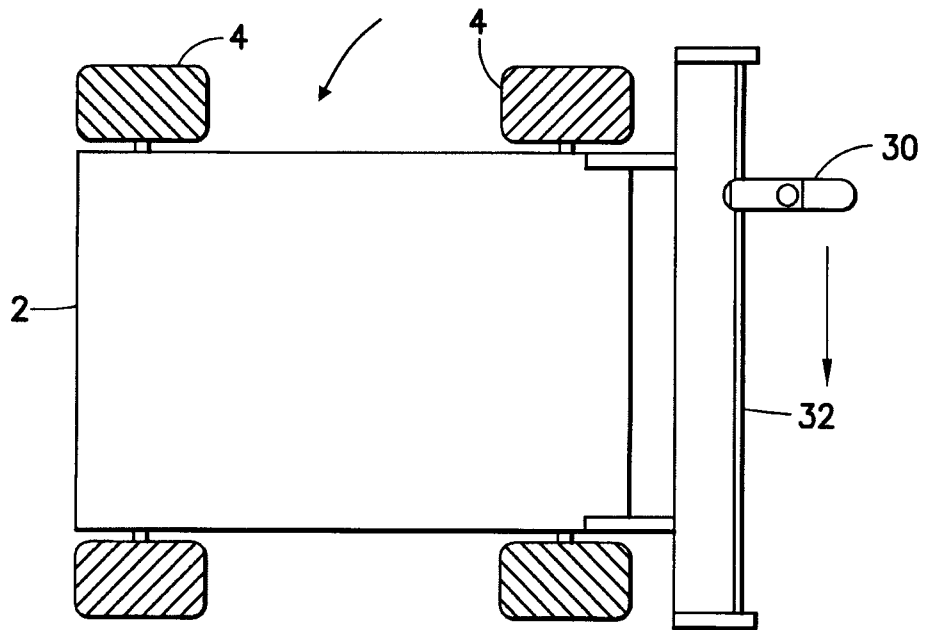

FIG. 11B

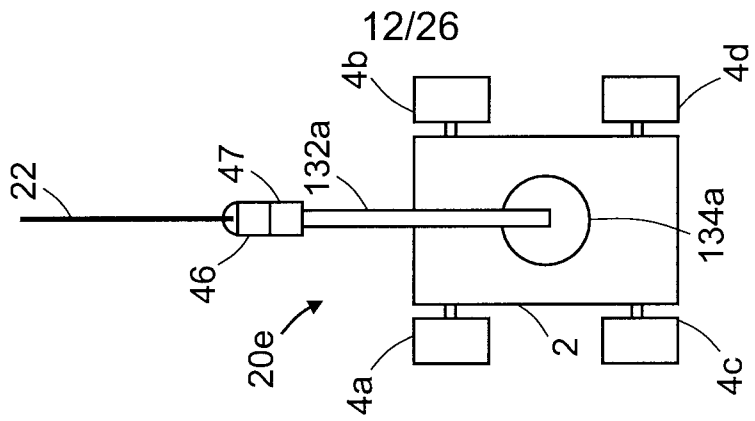

FIG. 12A

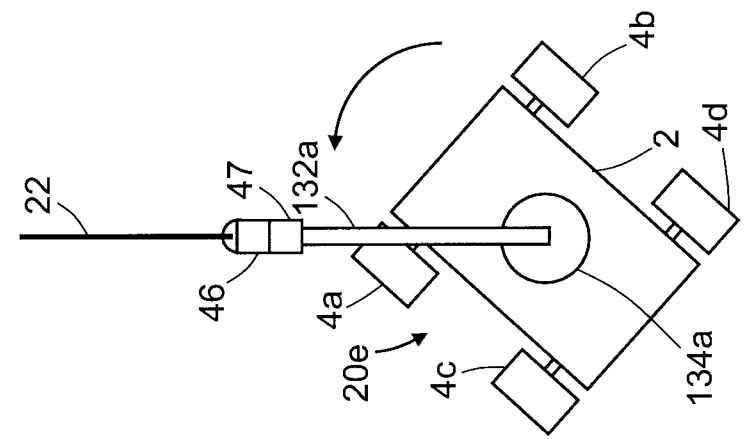

FIG. 12B

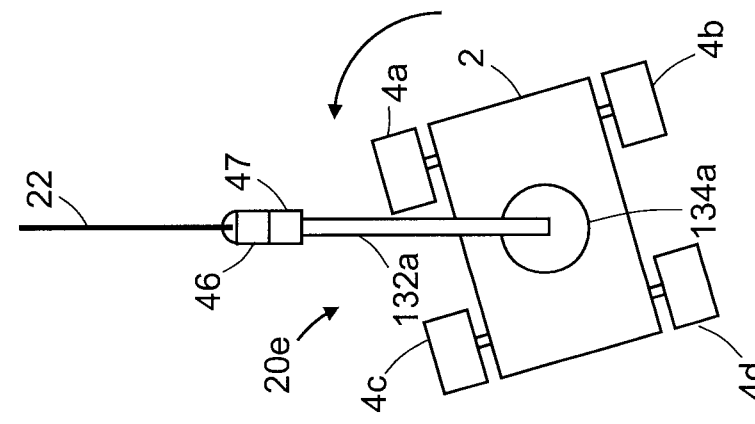

FIG. 12C

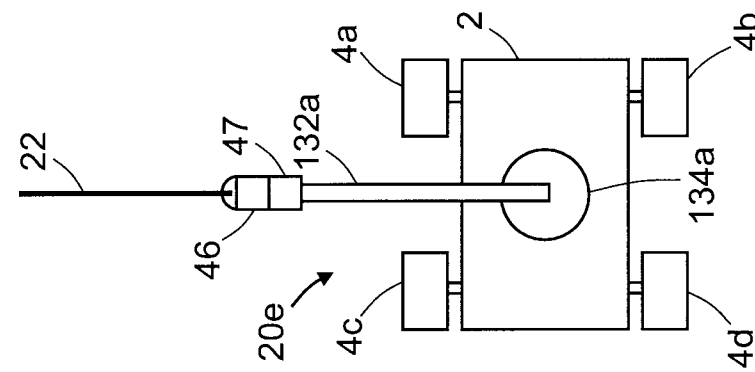

FIG. 12D

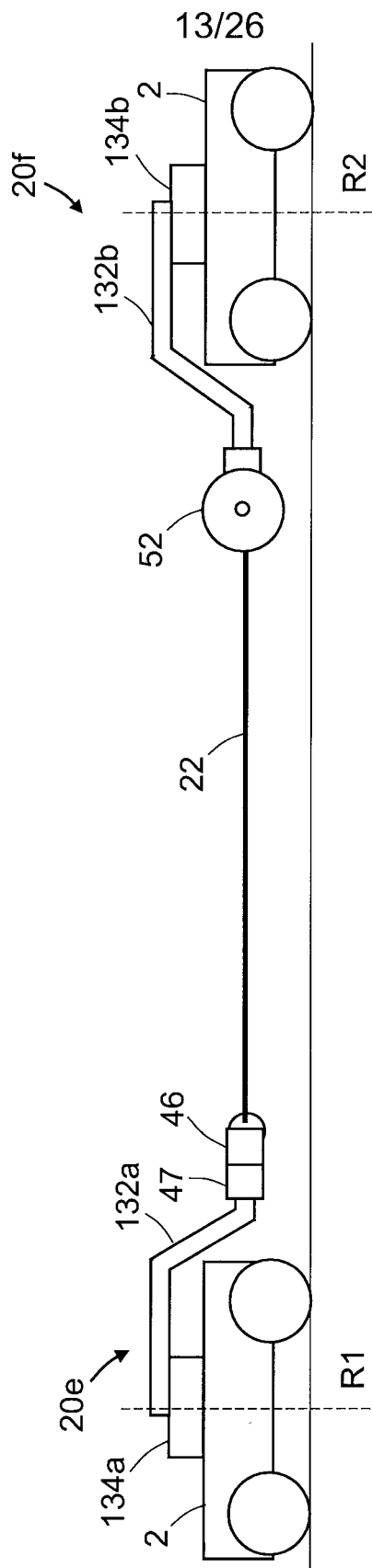

FIG. 13

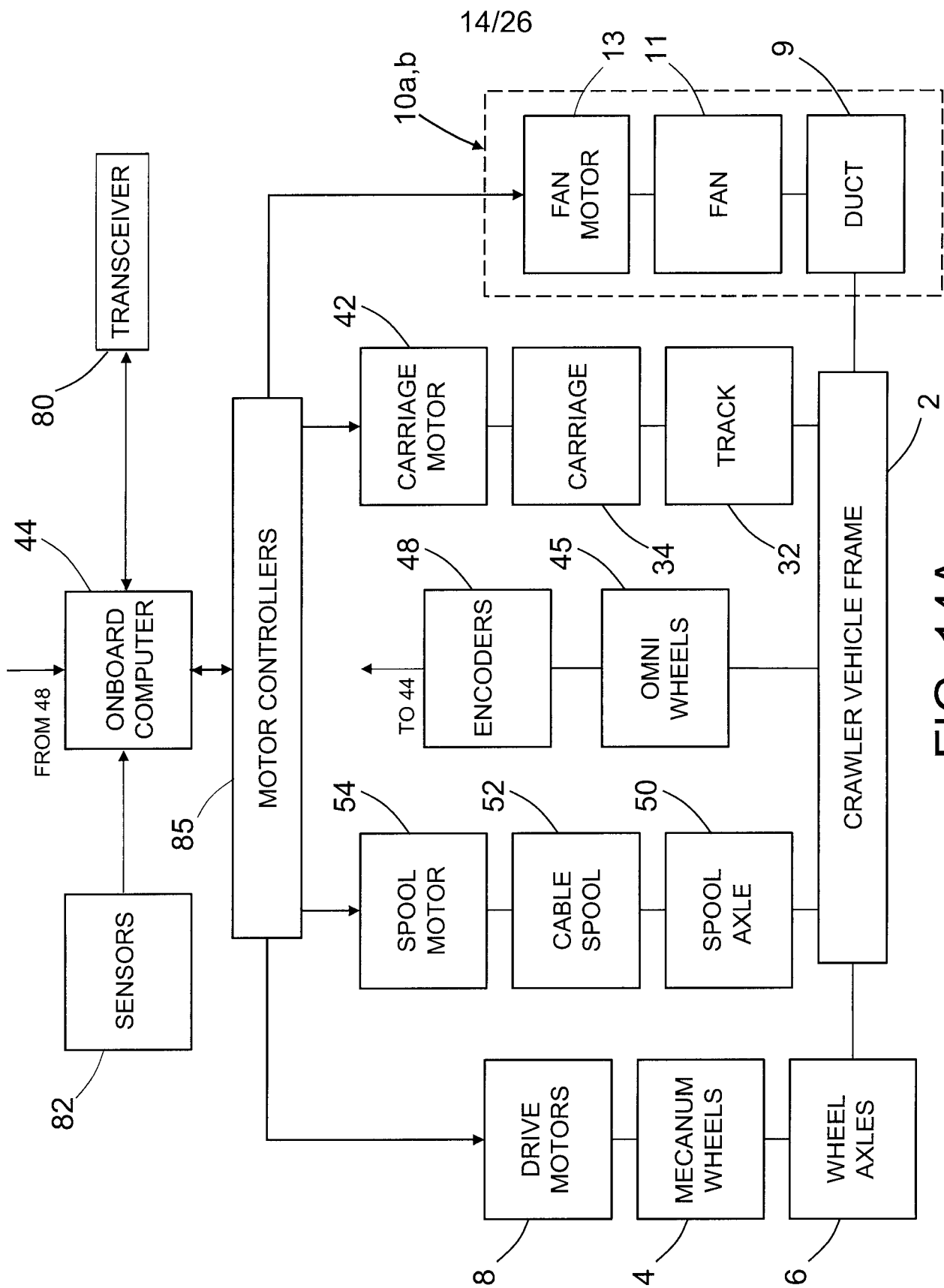

FIG. 14A

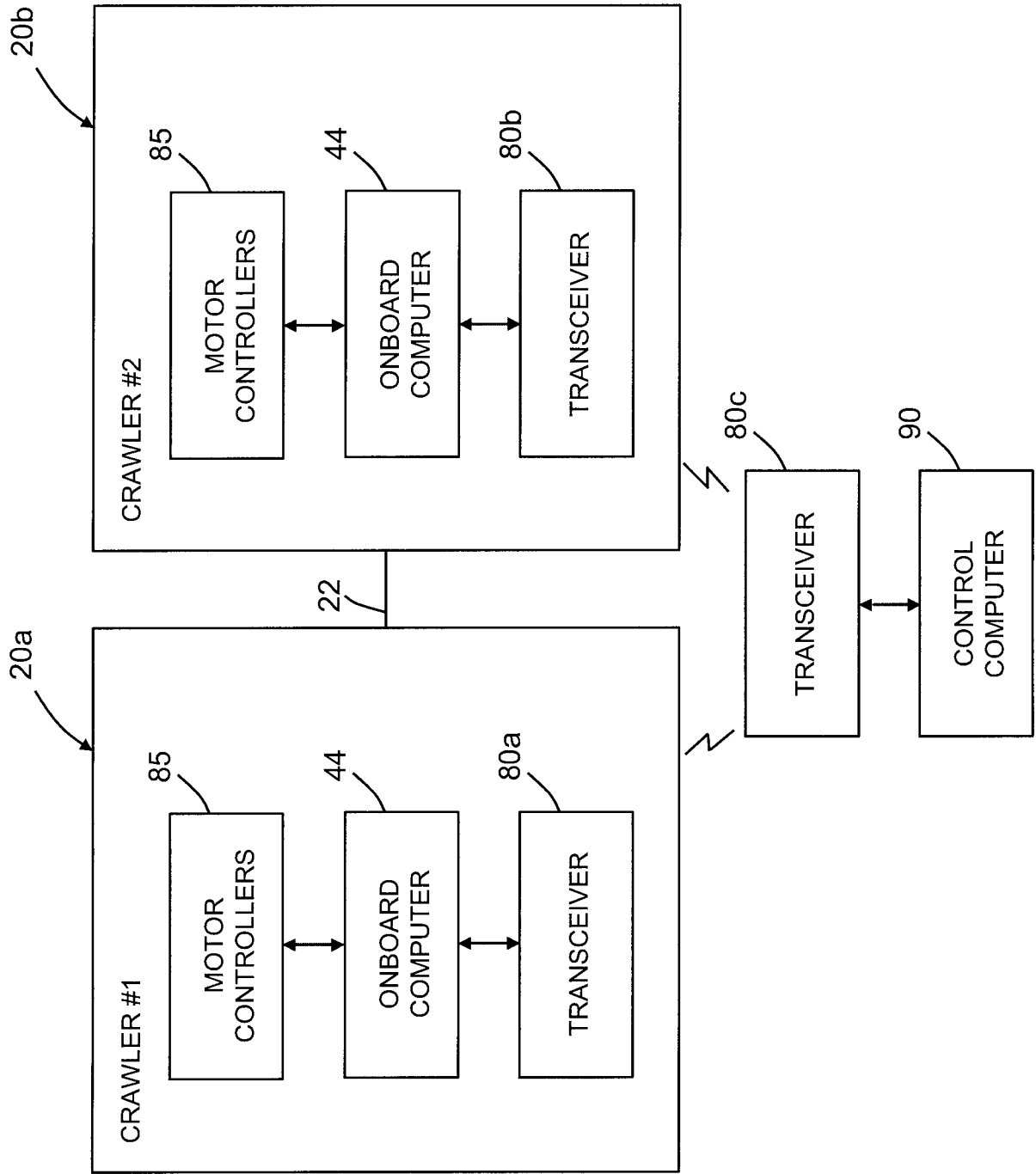

FIG. 14B

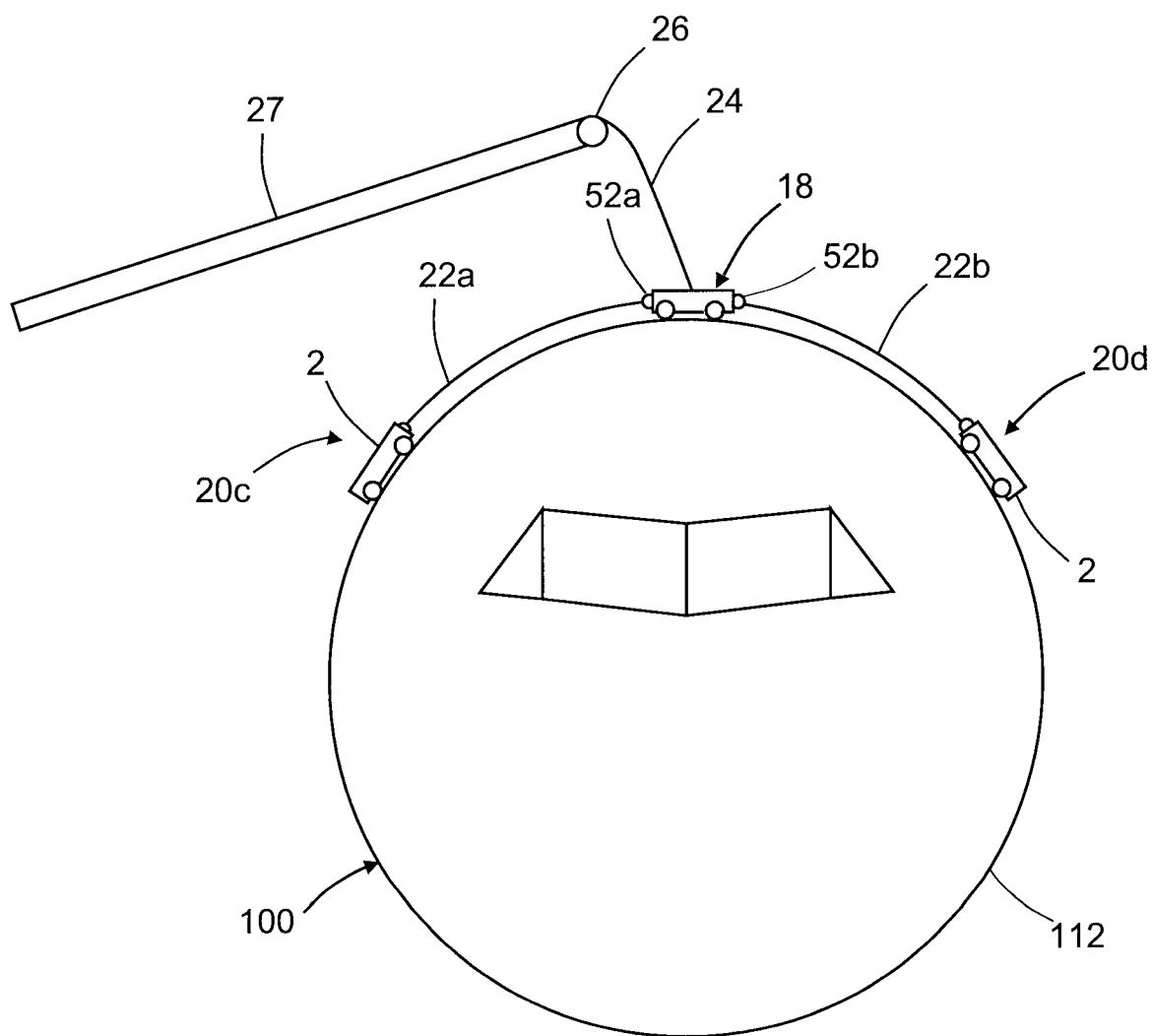

FIG. 15

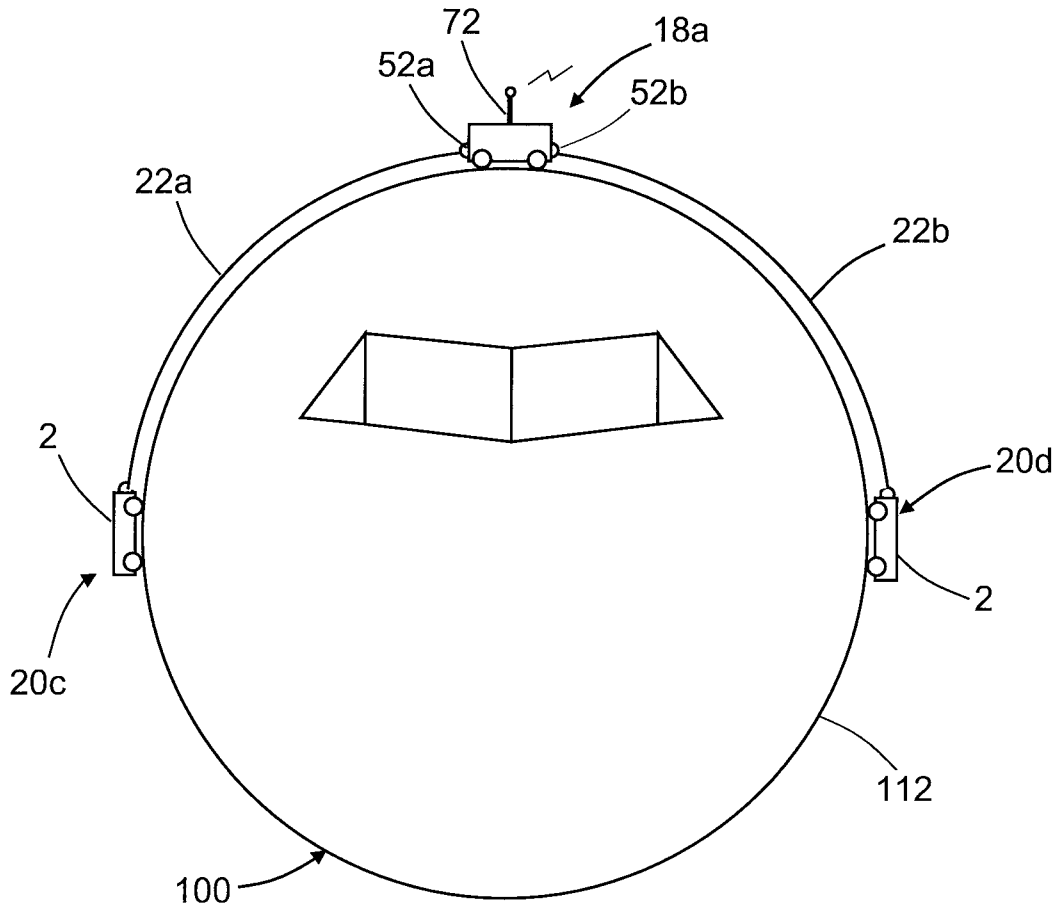

FIG. 16

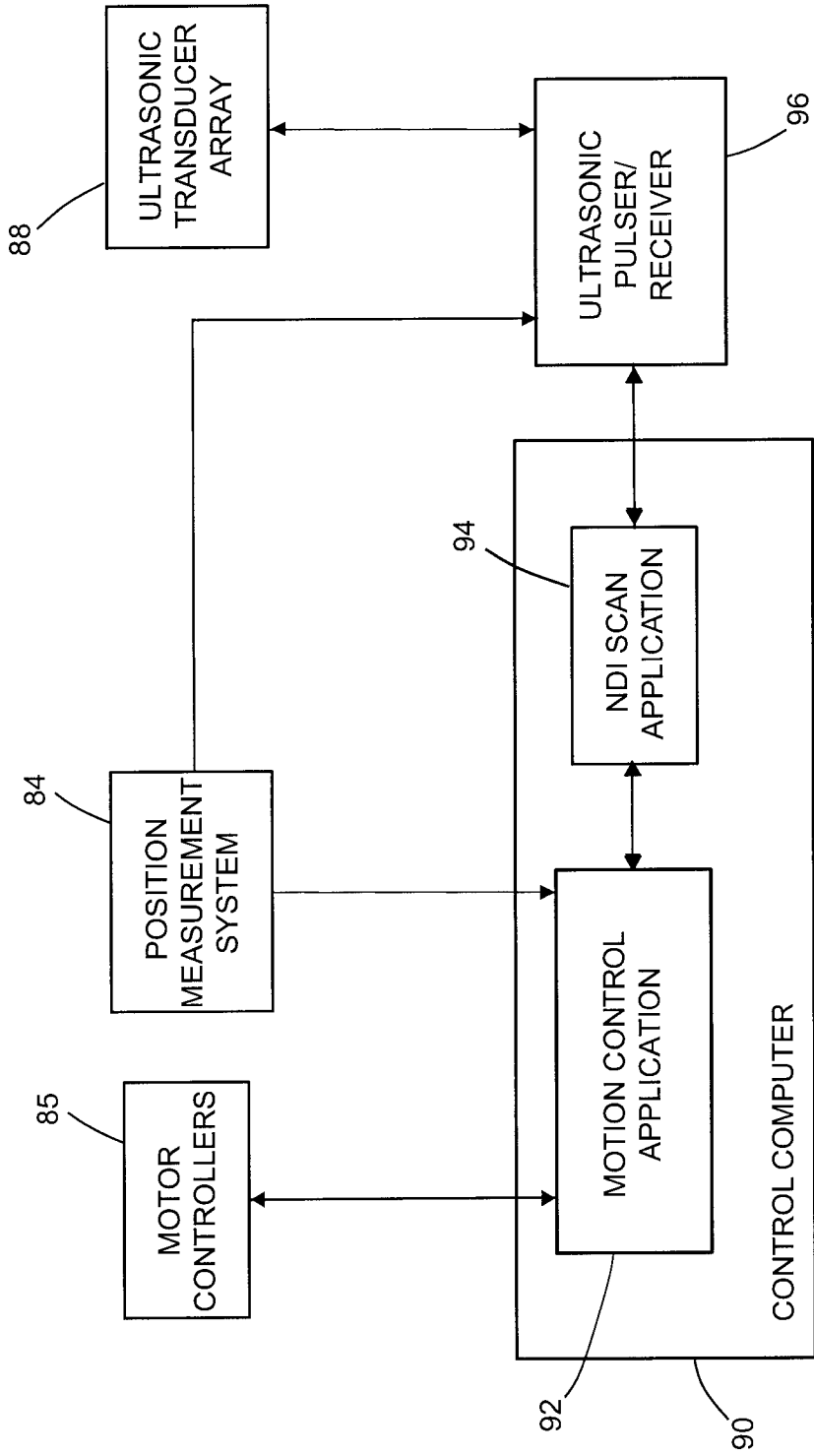

FIG. 17

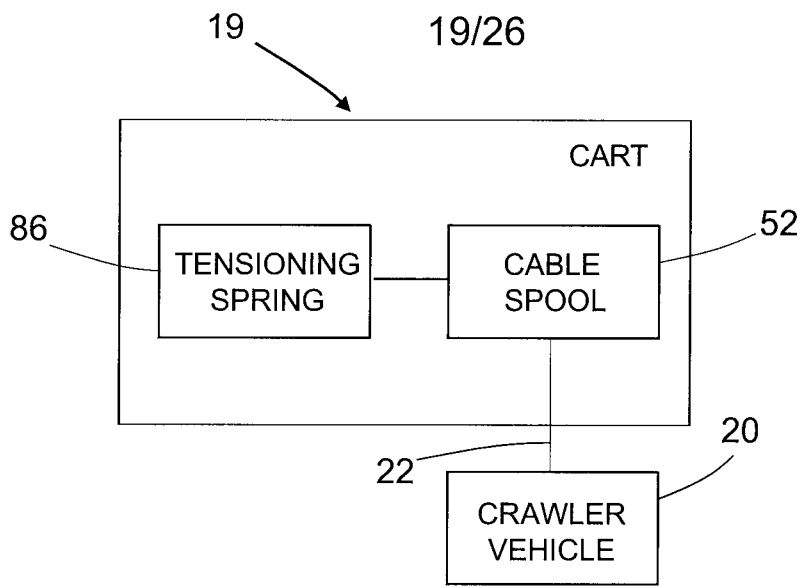

FIG. 18A

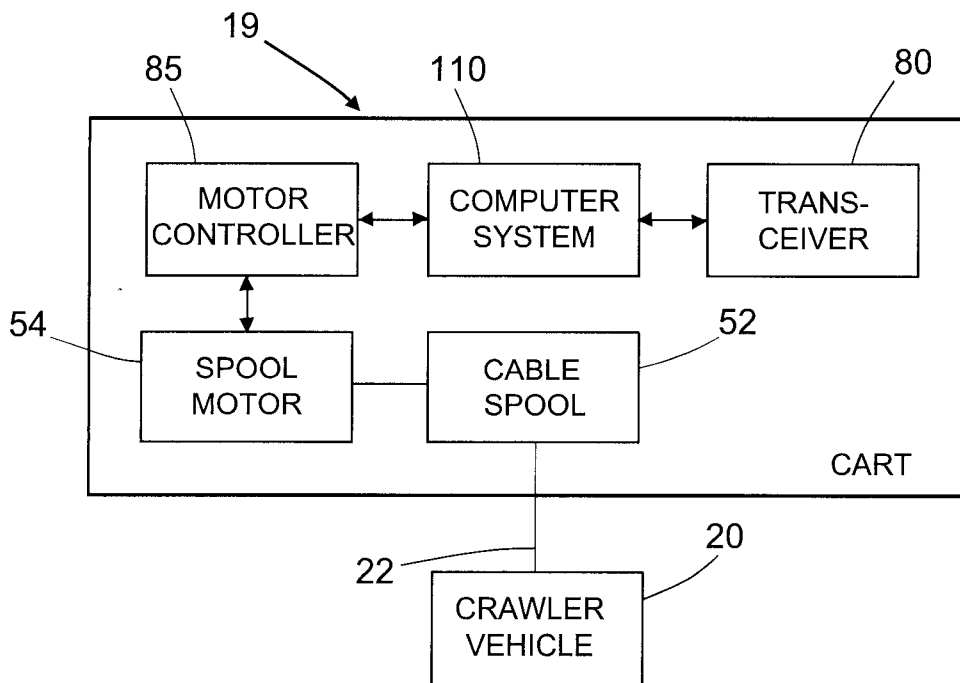

FIG. 18B

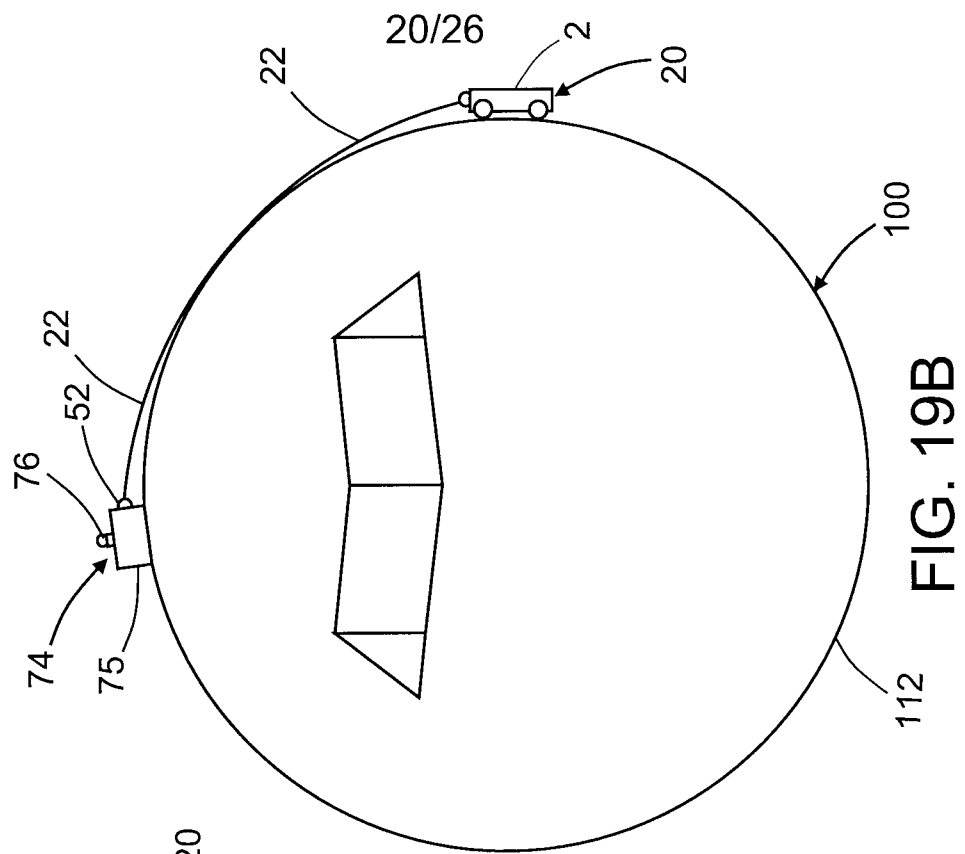

FIG. 19B

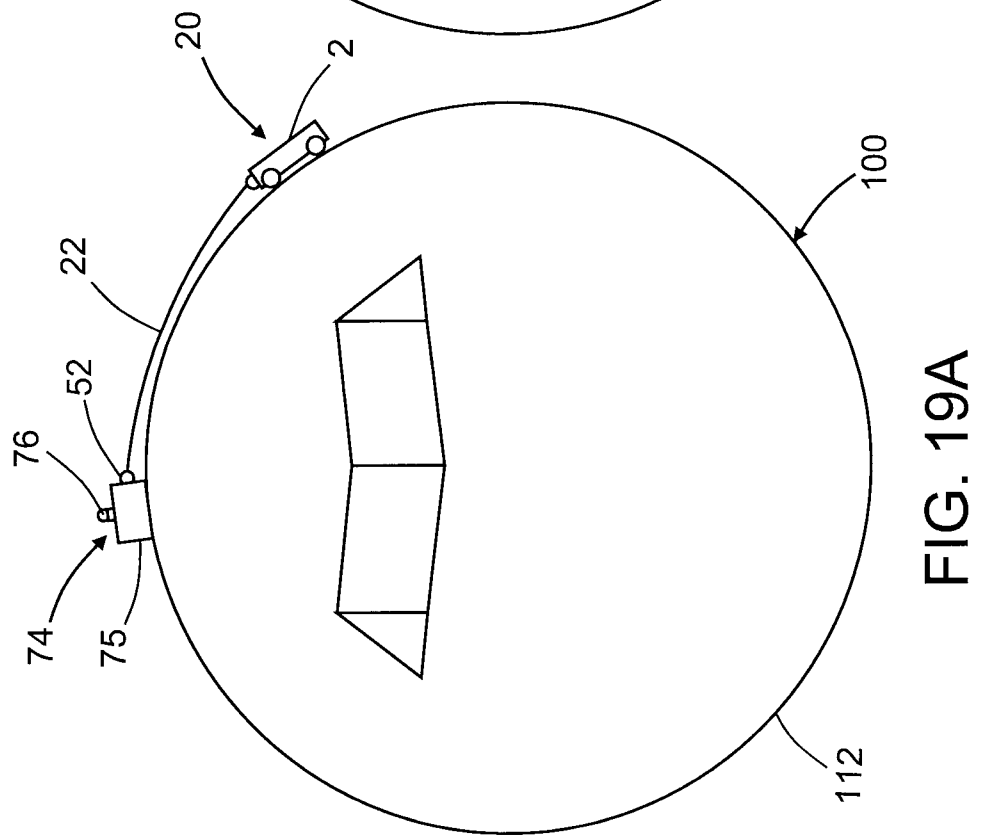

FIG. 19A

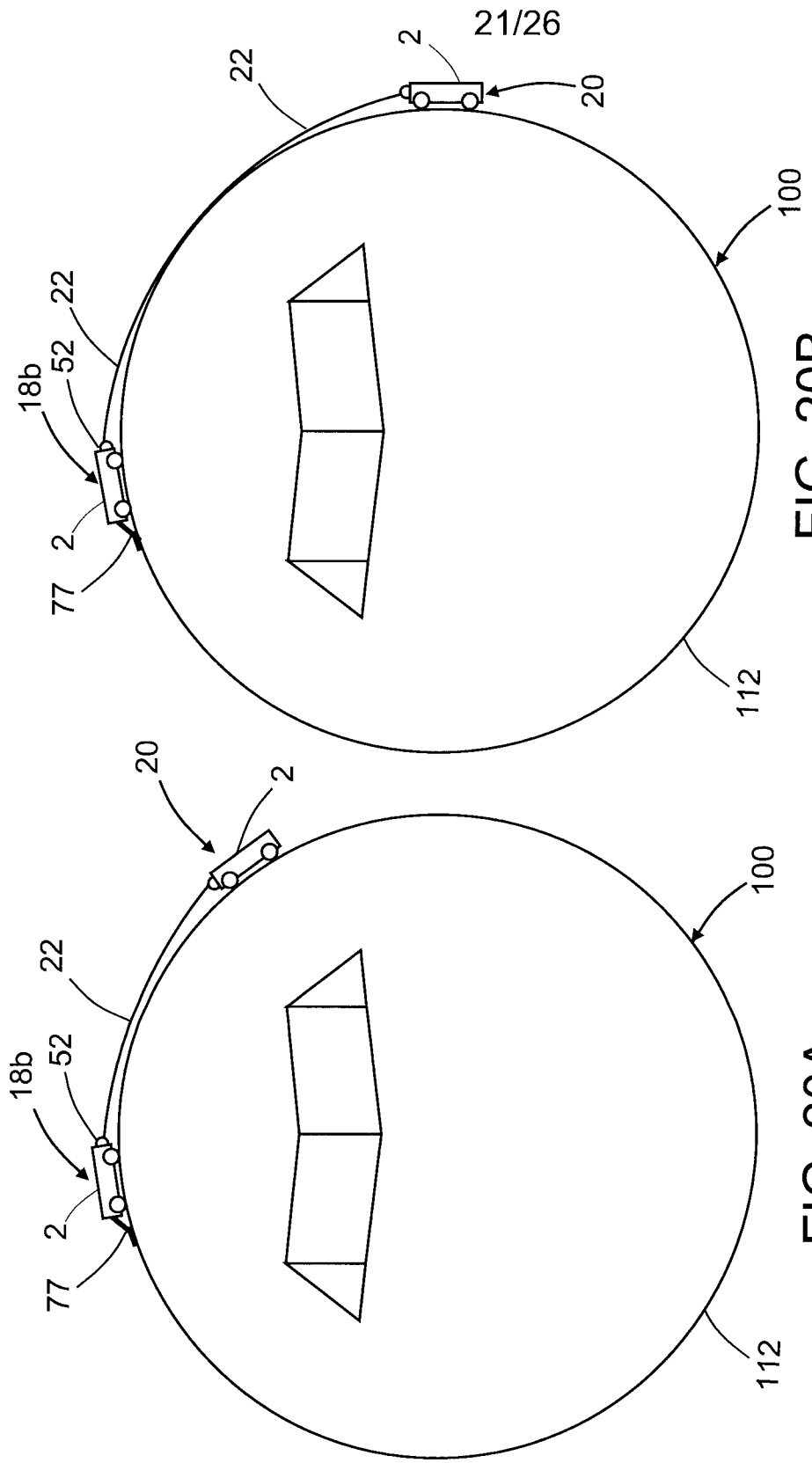

FIG. 20B

FIG. 20A

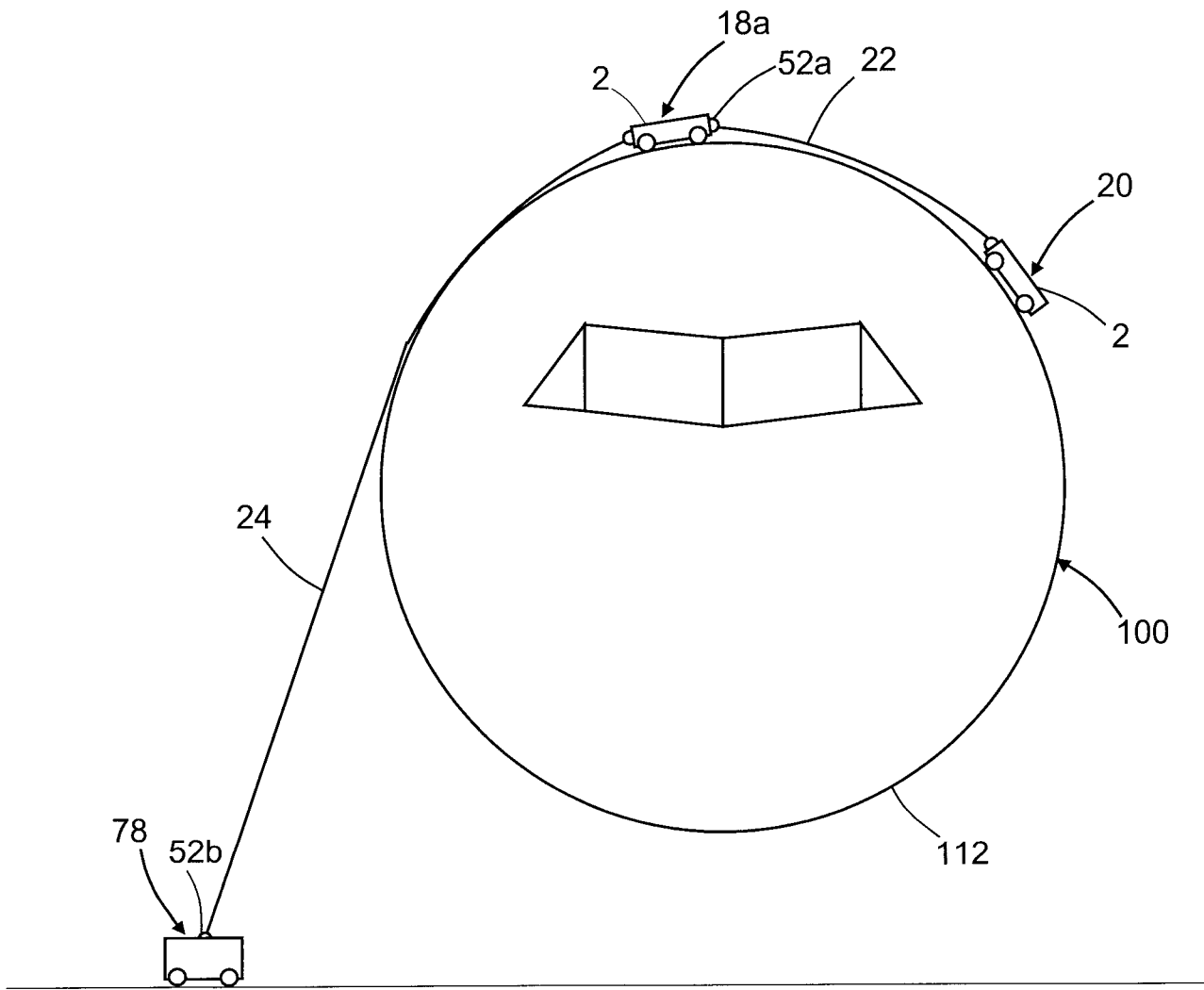

FIG. 21

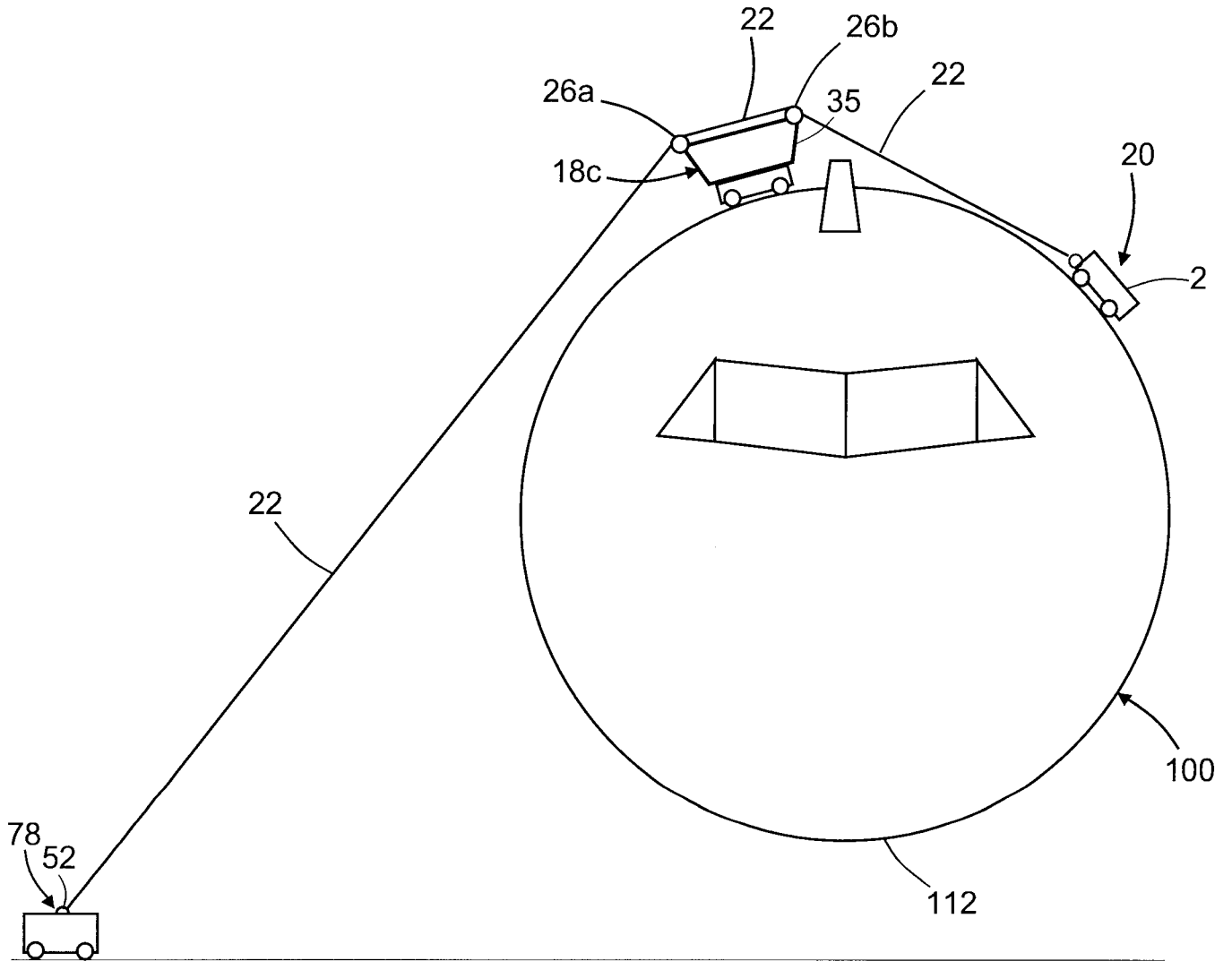

FIG. 22

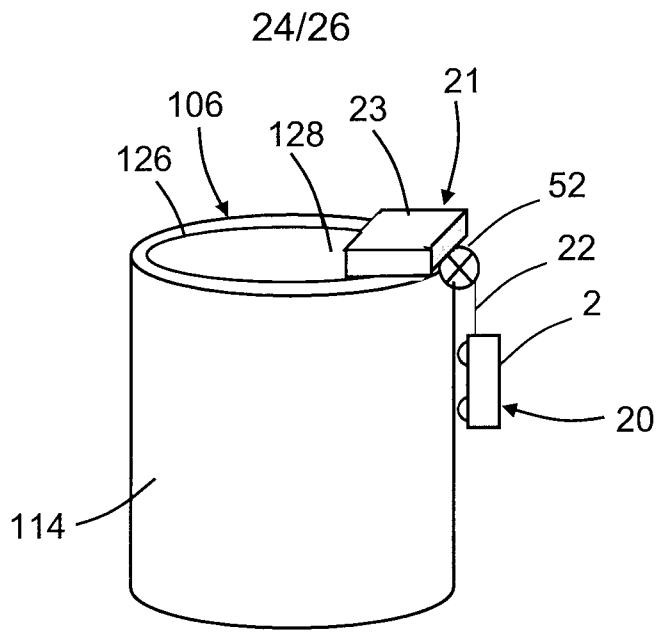

FIG. 23

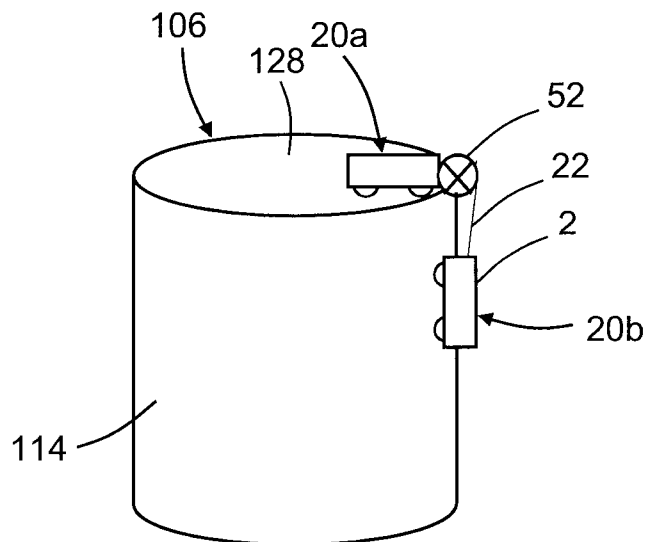

FIG. 24

25/26

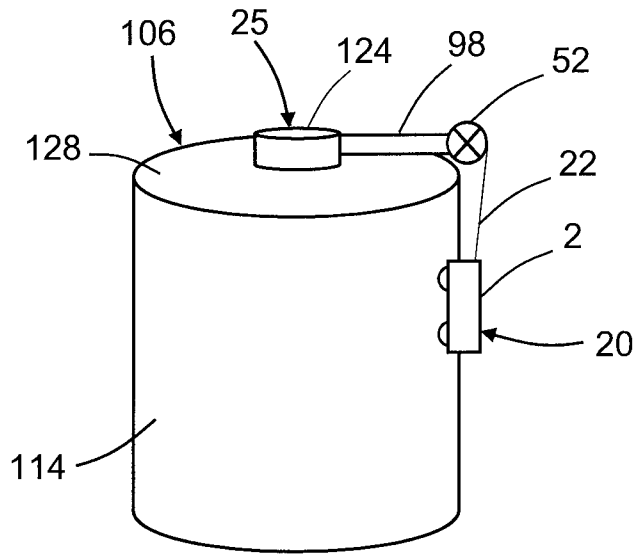

FIG. 25

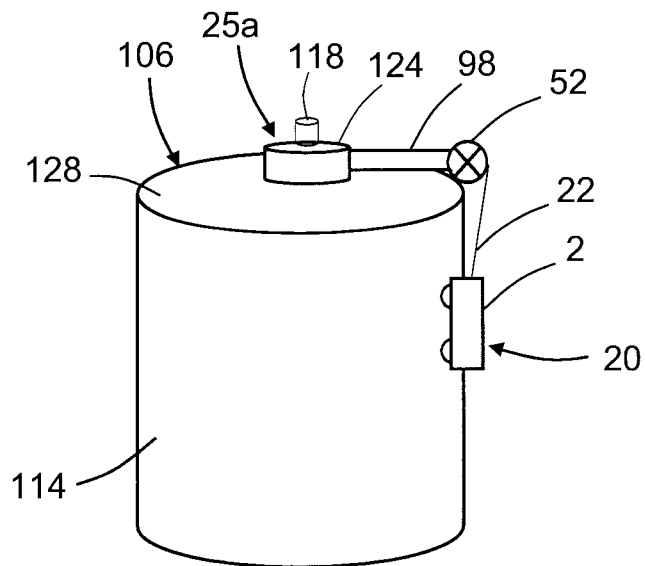

FIG. 26

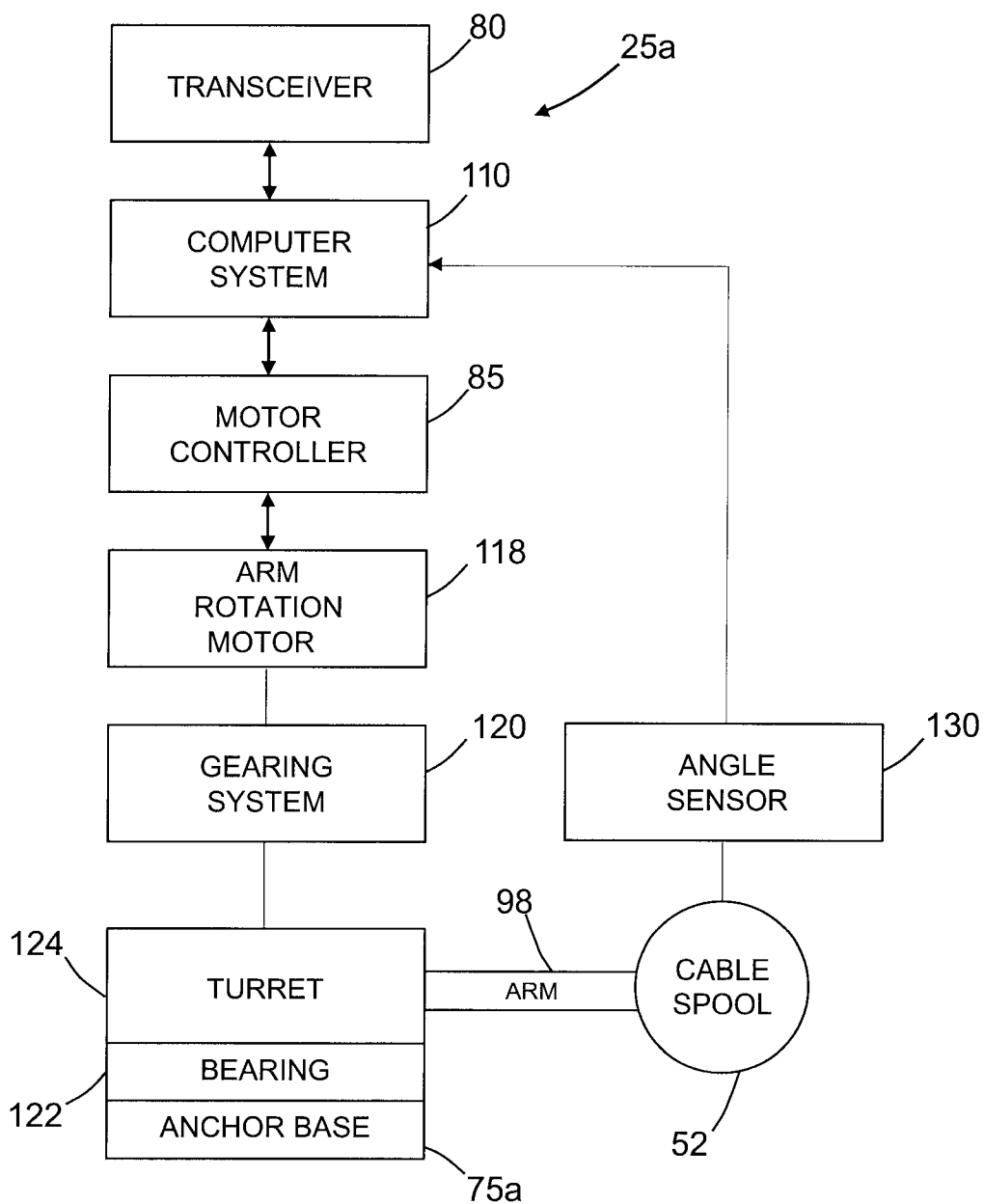

FIG. 27

