



US 20180008472A1

(19) **United States**

(12) **Patent Application Publication**
Seguin et al.

(10) **Pub. No.: US 2018/0008472 A1**

(43) **Pub. Date: Jan. 11, 2018**

(54) **DEVICES FOR PROTECTING VULNERABLE SITES ON PATIENTS FROM LIQUID CONTAMINATION AND RELATED DEVICES, SYSTEMS, AND METHODS**

A61F 13/02 (2006.01)

A61F 15/00 (2006.01)

(52) **U.S. Cl.**

CPC ... *A61F 13/00063* (2013.01); *A61F 13/0203* (2013.01); *A61F 13/12* (2013.01); *A61B 2046/205* (2016.02); *A61F 15/008* (2013.01); *A61F 2013/00272* (2013.01); *A61F 15/004* (2013.01)

(71) Applicant: **Cenorin, LLC**, Kent, WA (US)

(72) Inventors: **Art Seguin**, West Jordan, UT (US);
Gerry Arambula, Seattle, WA (US)

(21) Appl. No.: **15/667,567**

(22) Filed: **Aug. 2, 2017**

Related U.S. Application Data

(63) Continuation of application No. 14/225,268, filed on Mar. 25, 2014, now Pat. No. 9,724,242.

(60) Provisional application No. 61/805,483, filed on Mar. 26, 2013.

Publication Classification

(51) **Int. Cl.**

A61F 13/00 (2006.01)

A61F 13/12 (2006.01)

(57) **ABSTRACT**

A protective device configured in accordance with a particular embodiment includes a cover including a first region that extends over a vulnerable site on a patient and a second region that extends over an area on the patient peripheral to the vulnerable site. The first region of the cover is at least generally impermeable to liquid water. The device further includes an adhesive film and a liquid-absorbing element. The adhesive film is configured to form an adhesive bond between the second region of the cover and the patient. The bond has an inner edge portion positioned toward the vulnerable site and an outer edge portion positioned away from the vulnerable site. The liquid-absorbing element is configured to absorb liquid contamination at the outer edge portion of the bond and/or liquid contamination approaching the outer edge portion of the bond when the cover is operably positioned on the patient.

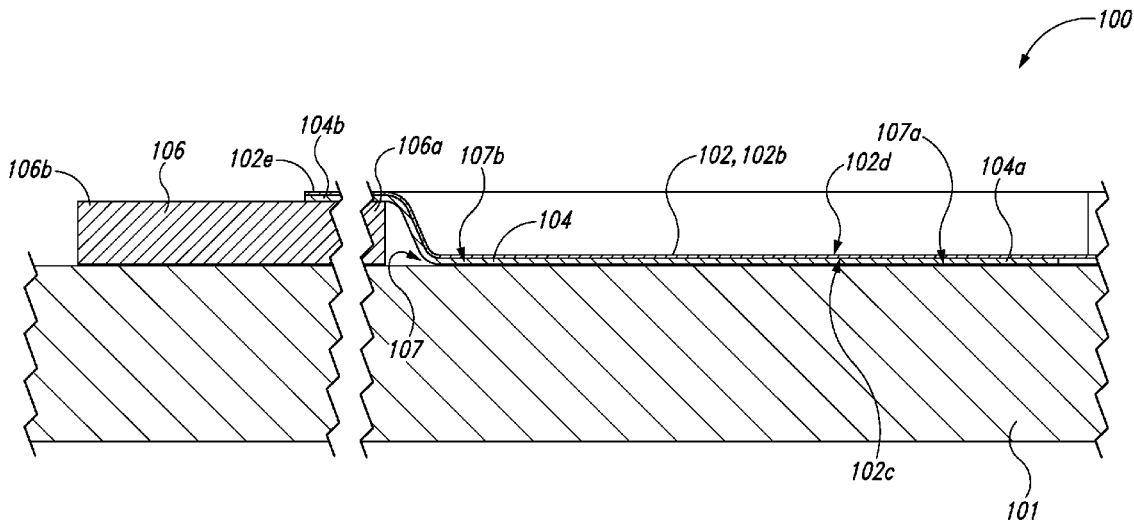

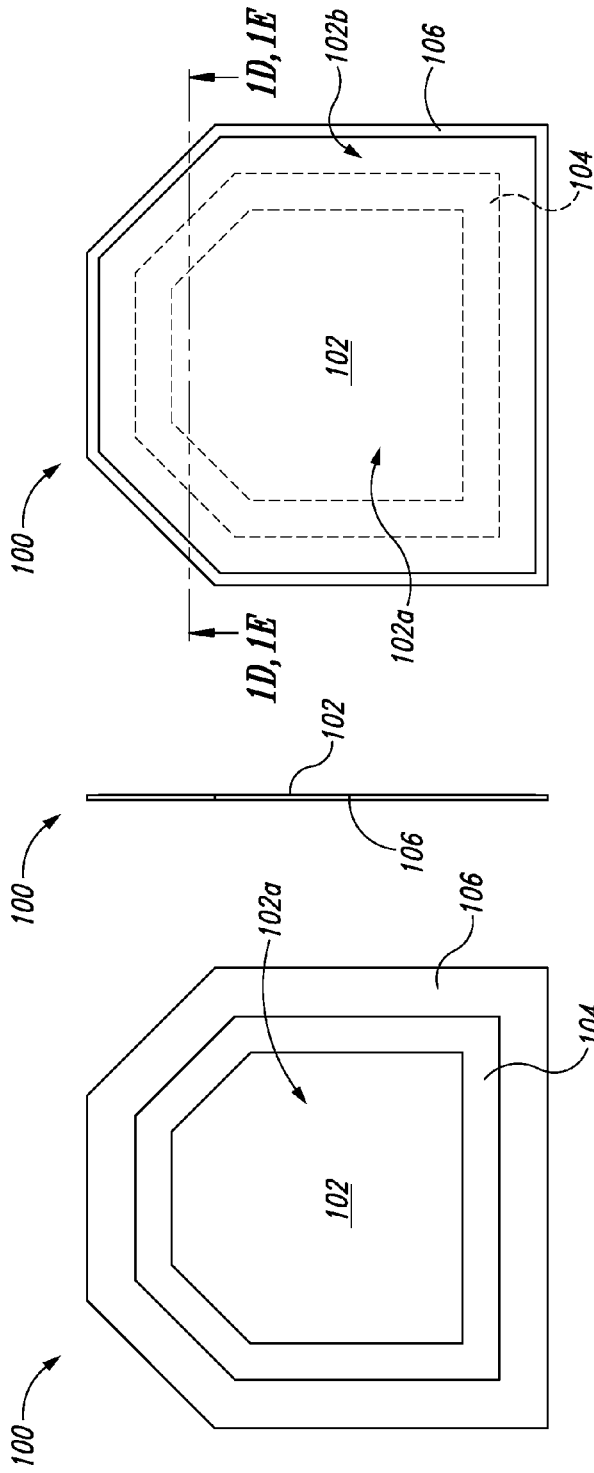

Fig. 1C

Fig. 1B

Fig. 1A

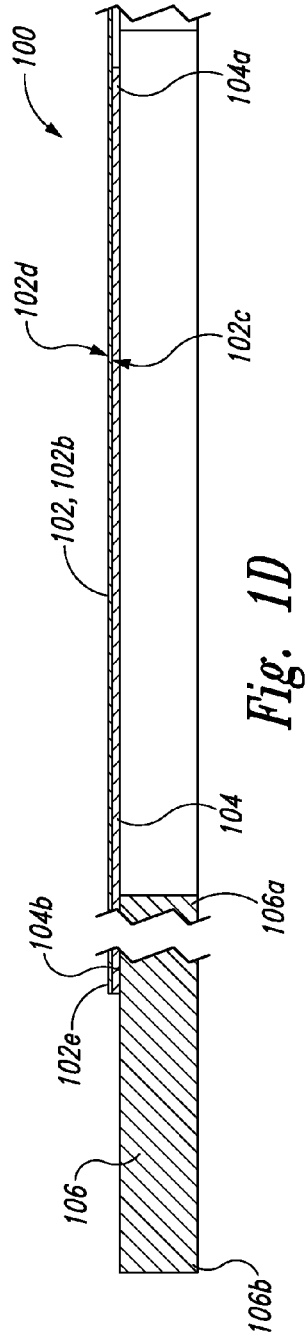

Fig. 1D

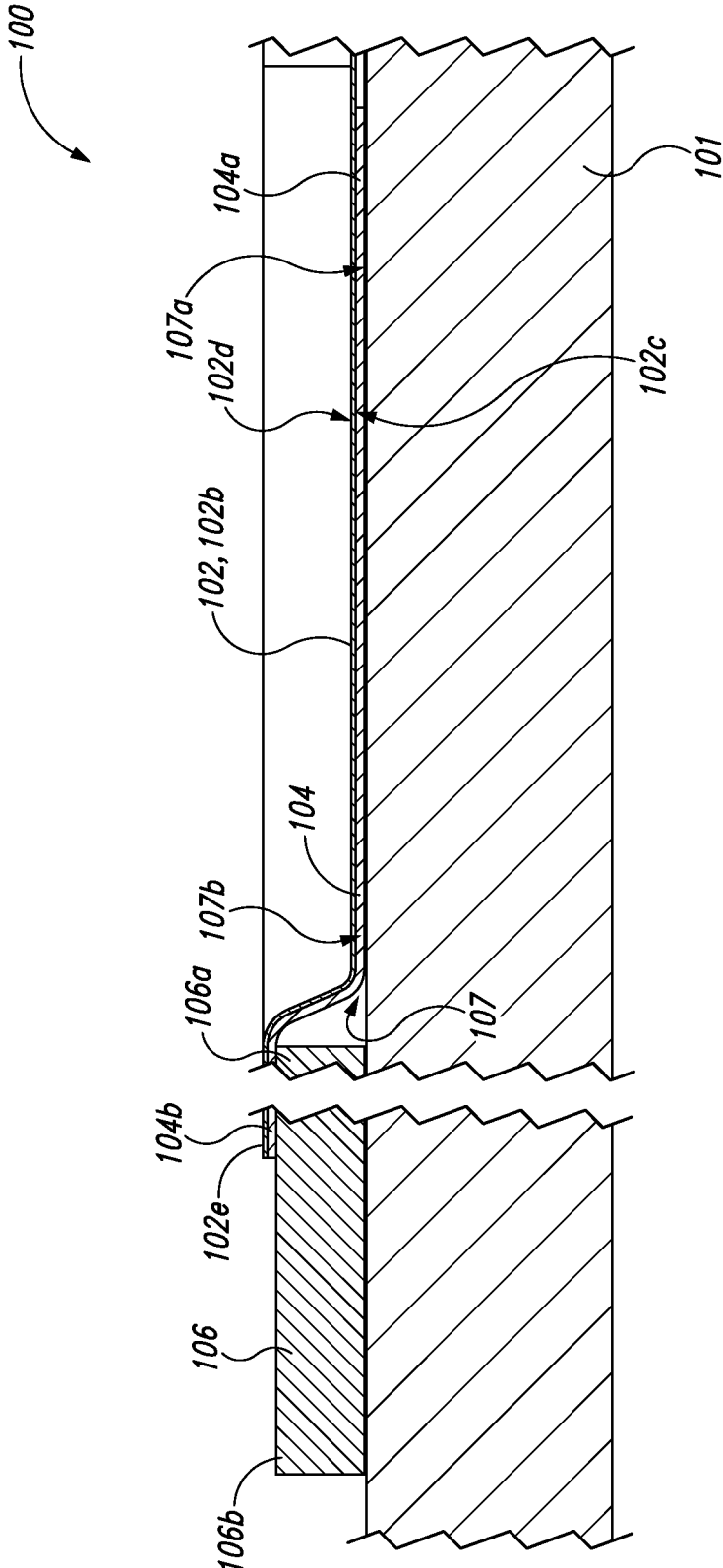

Fig. 1E

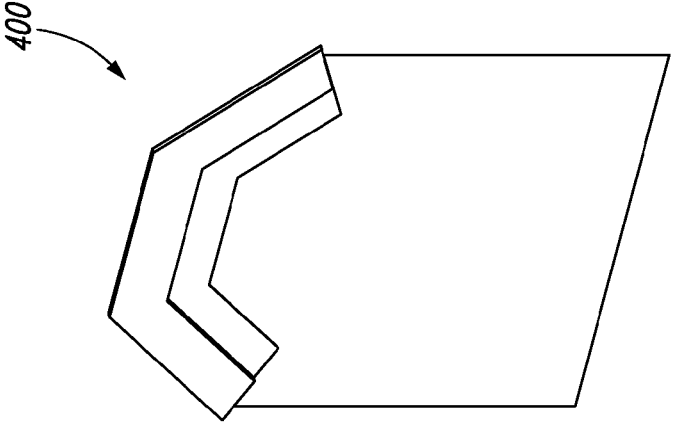

Fig. 2

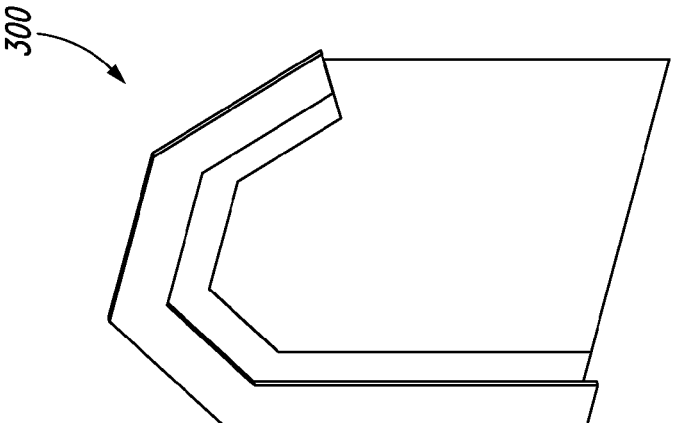

Fig. 3

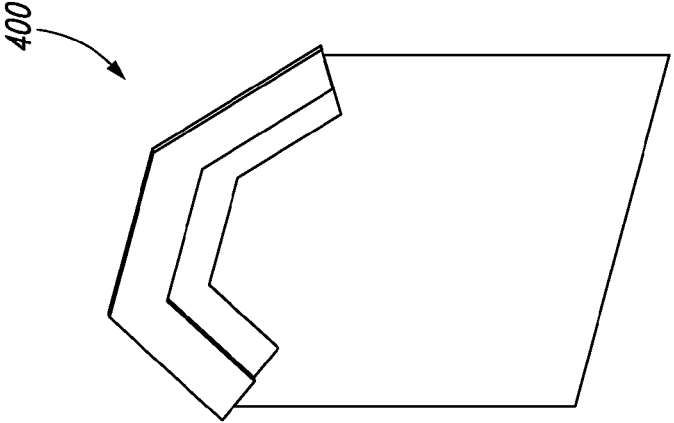

Fig. 4

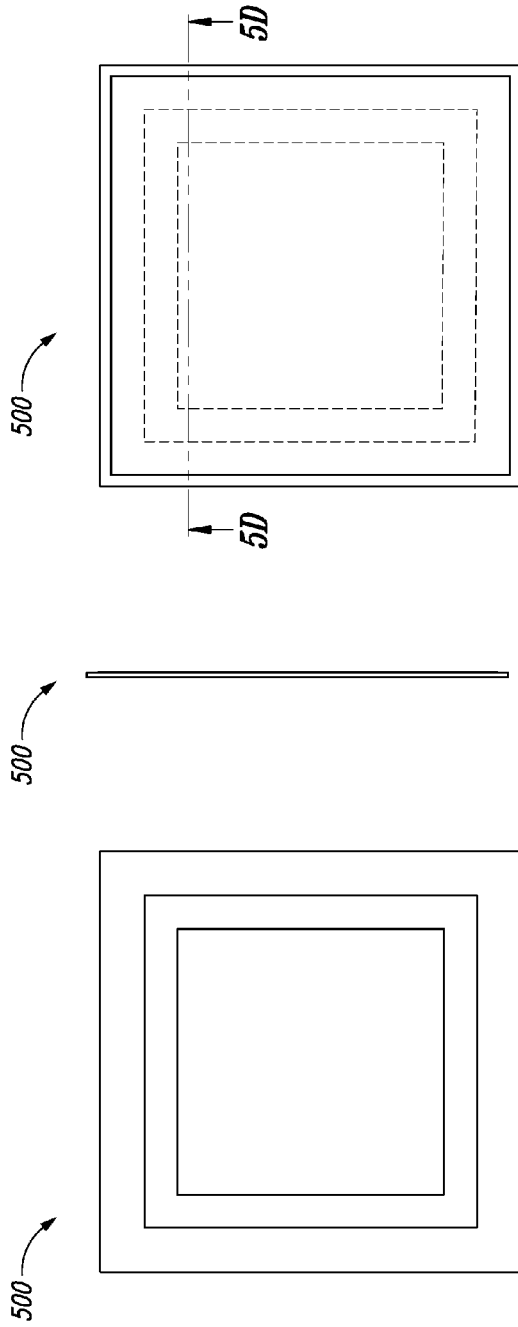

Fig. 5A Fig. 5B Fig. 5C

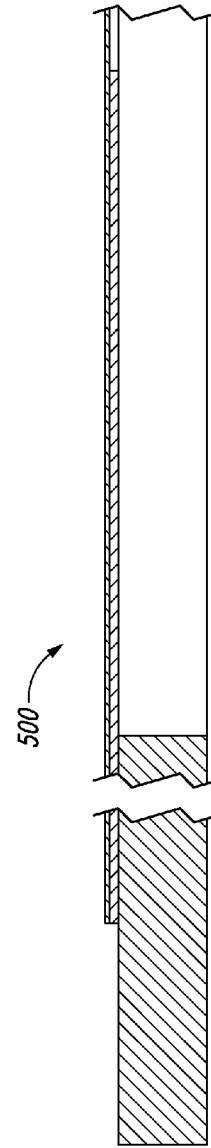

Fig. 5D

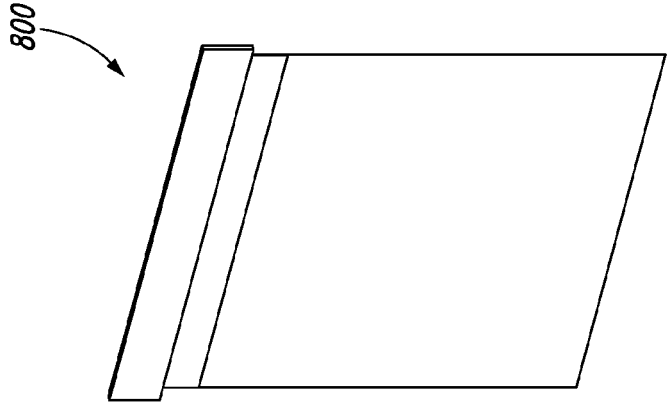

Fig. 8

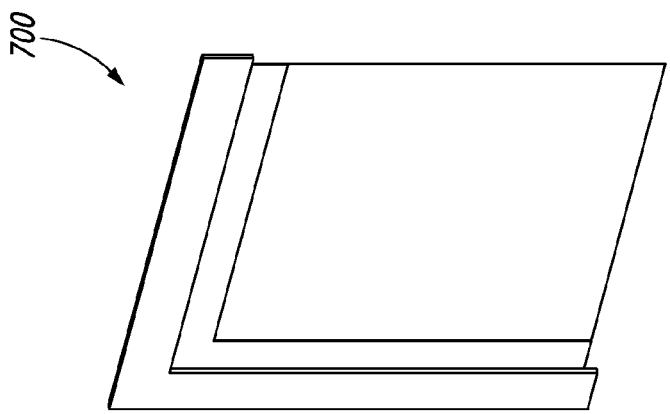

Fig. 7

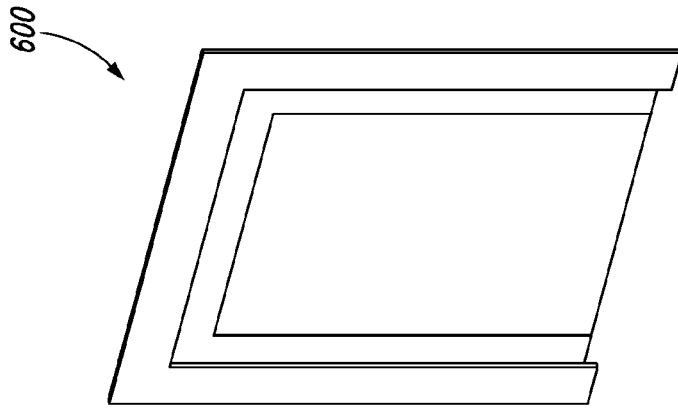

Fig. 6

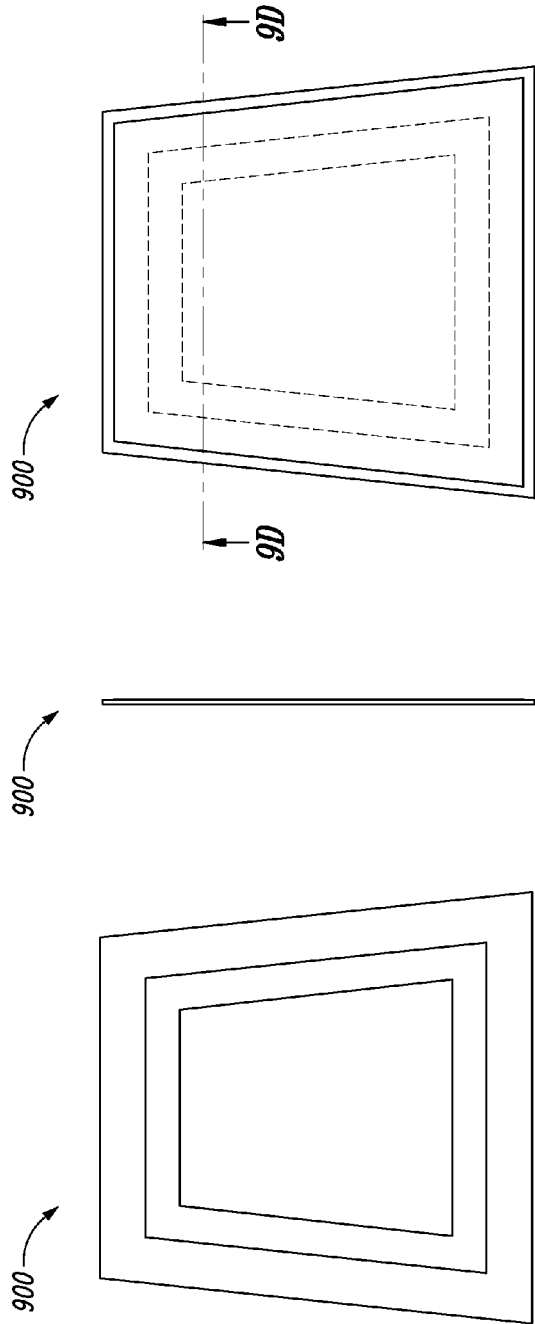

Fig. 9A Fig. 9B Fig. 9C

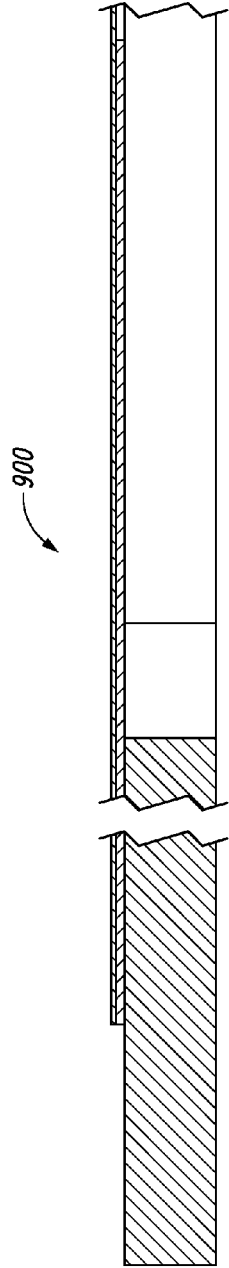

Fig. 9D

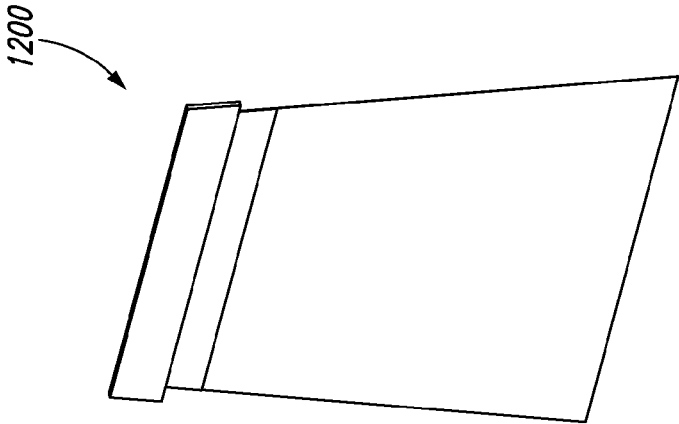

Fig. 10

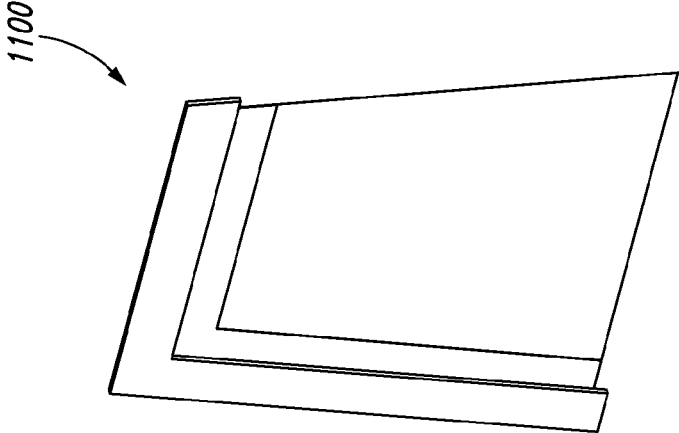

Fig. 11

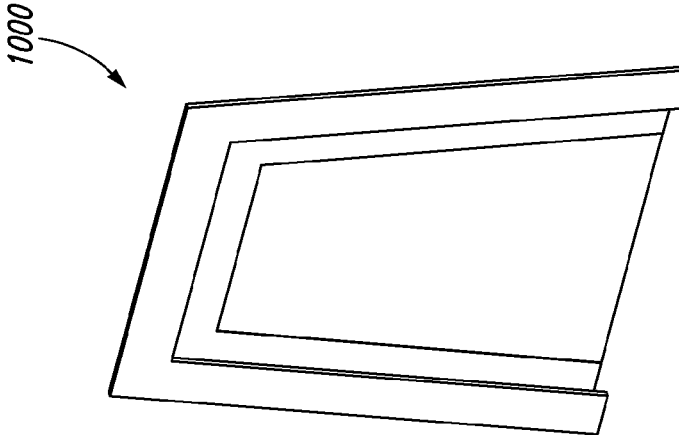

Fig. 12

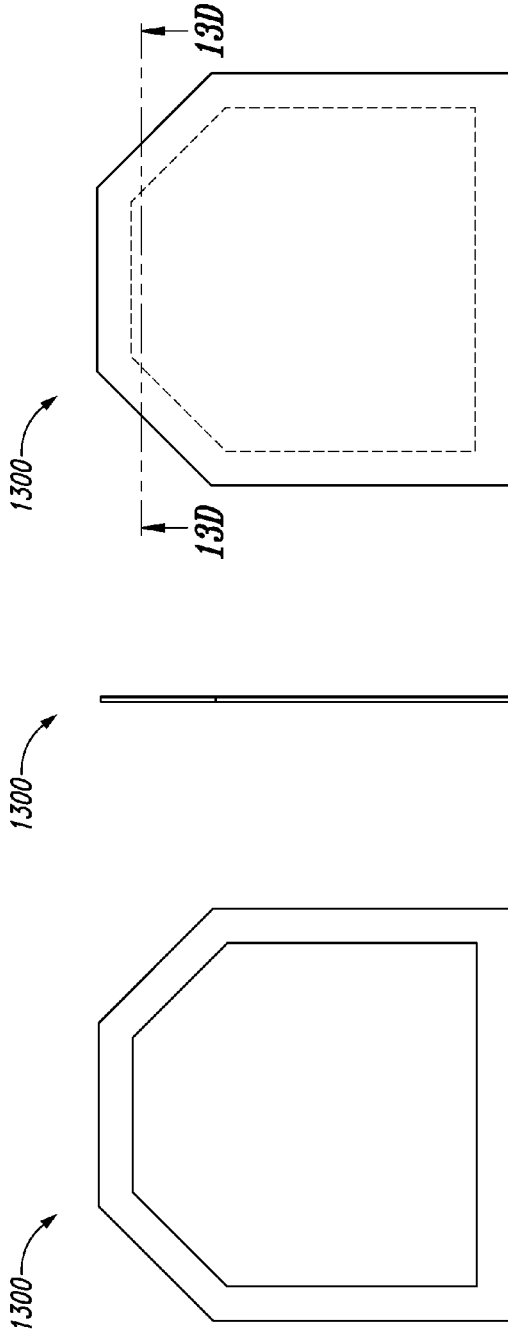

Fig. 13A Fig. 13B Fig. 13C

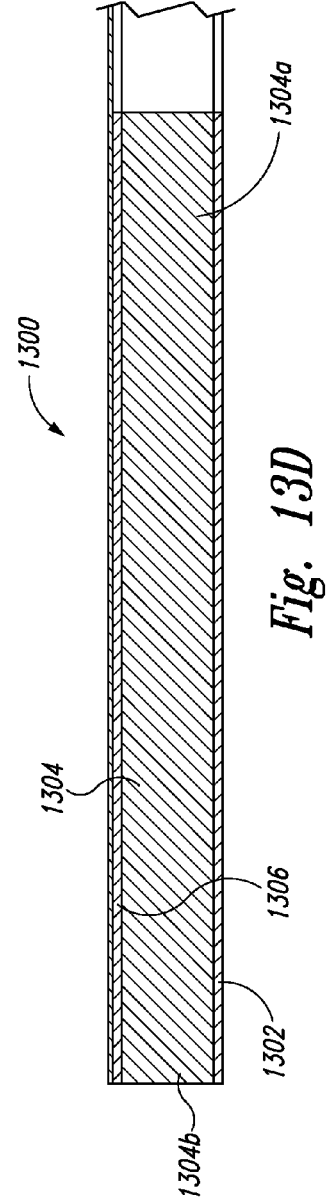

Fig. 13D

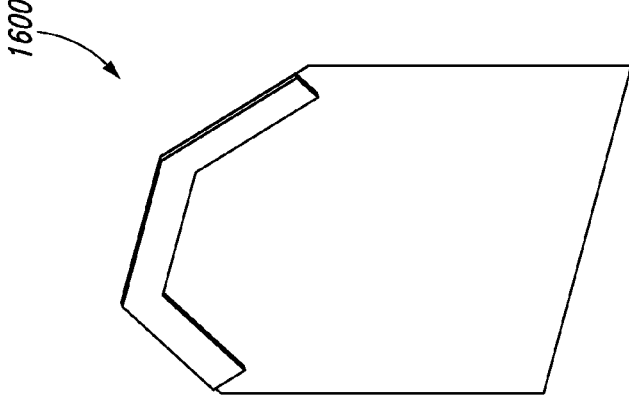

Fig. 14

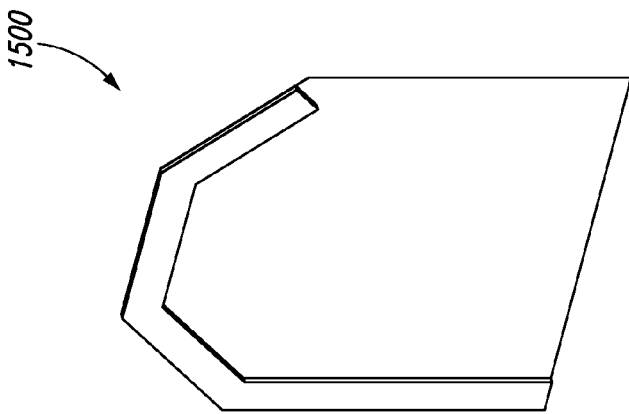

Fig. 15

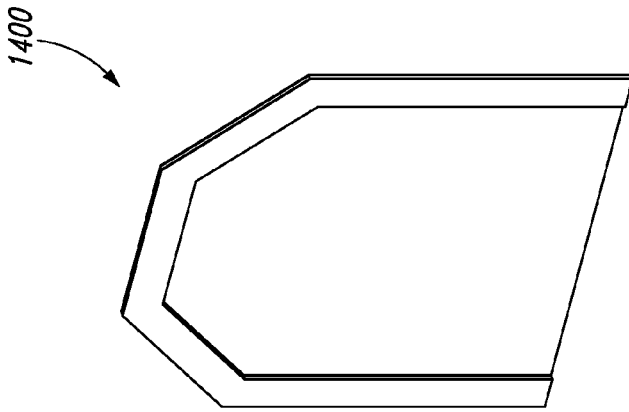

Fig. 16

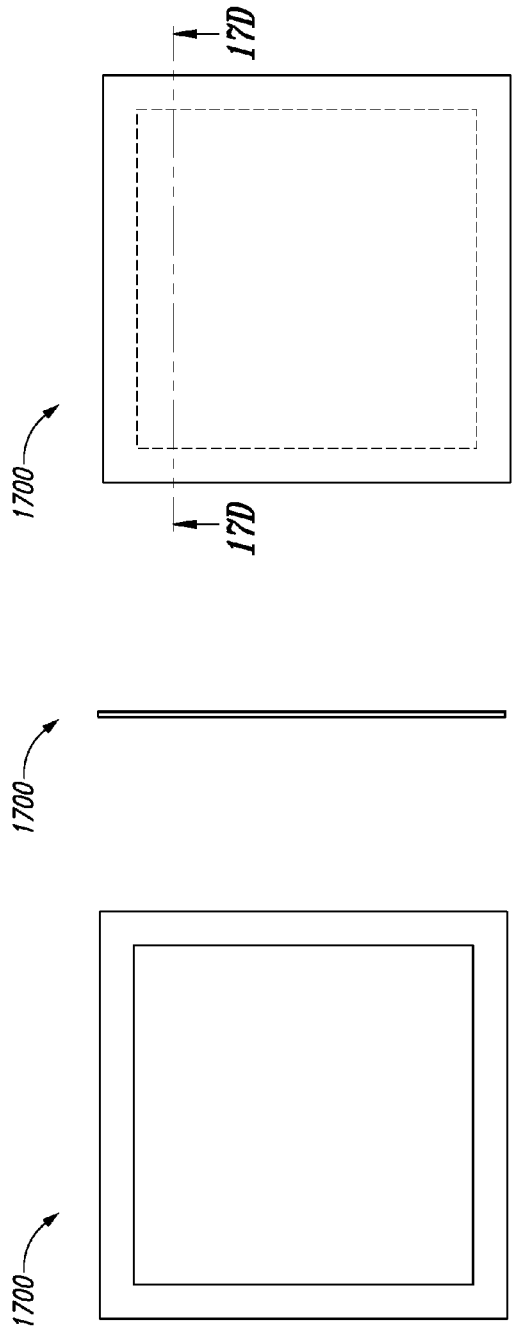

Fig. 17A Fig. 17B Fig. 17C

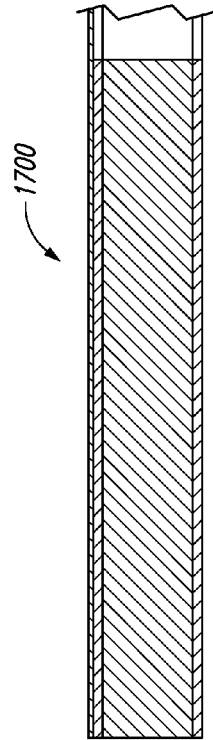

Fig. 17D

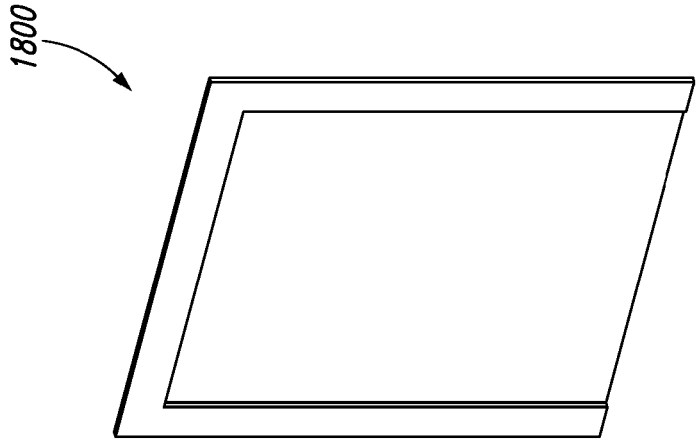
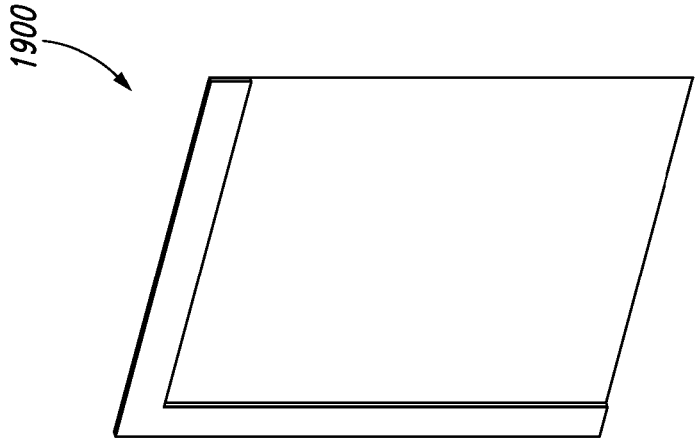
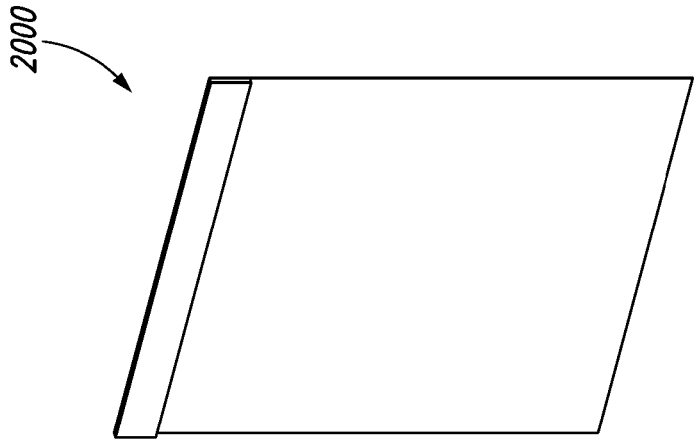

Fig. 20

Fig. 19

Fig. 18

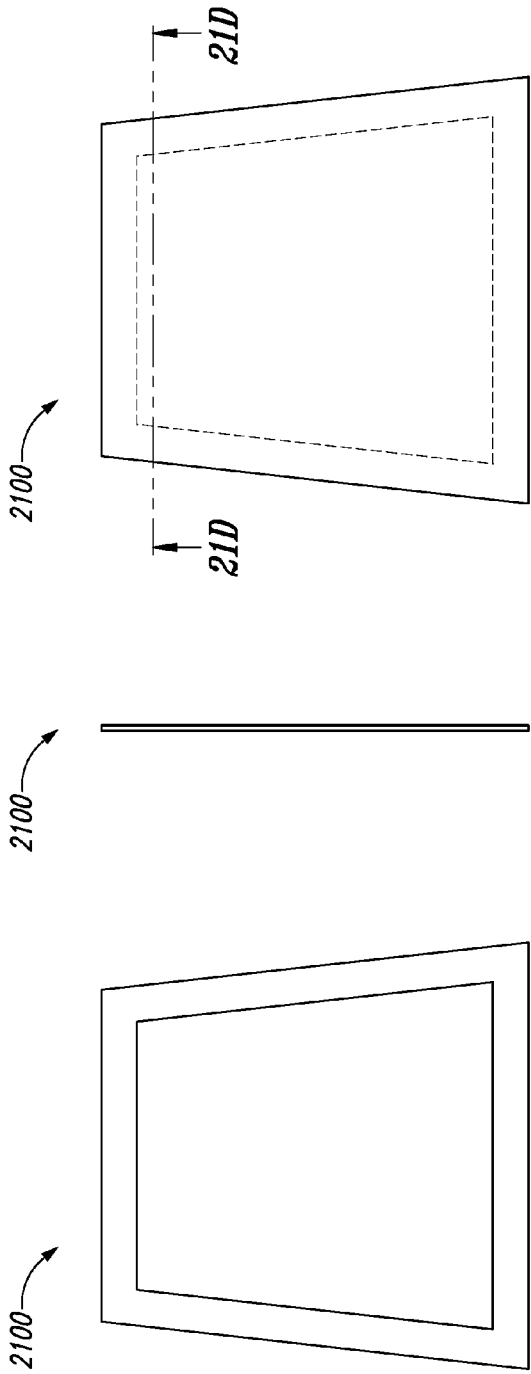

Fig. 21A Fig. 21B Fig. 21C

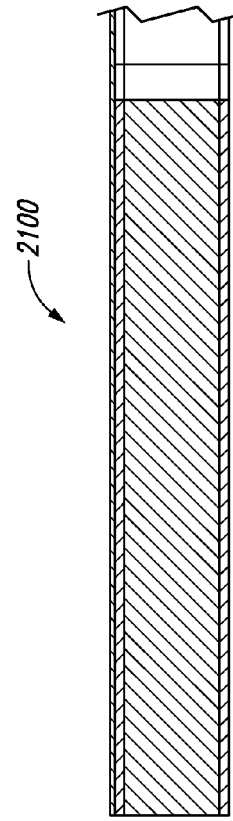

Fig. 21D

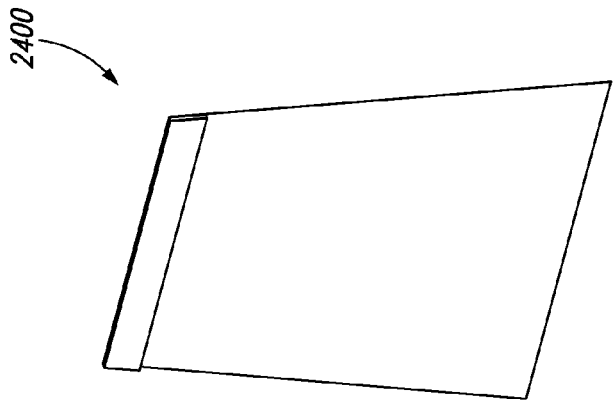

Fig. 24

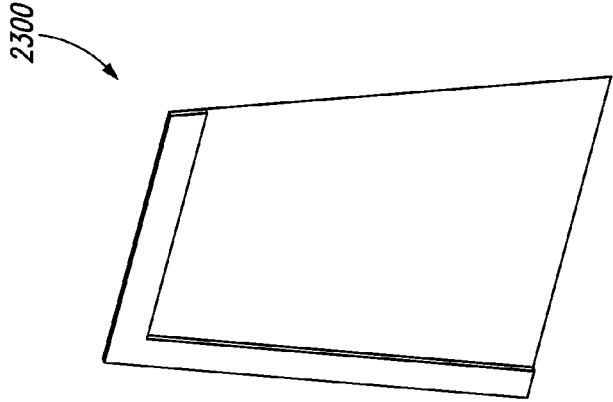

Fig. 23

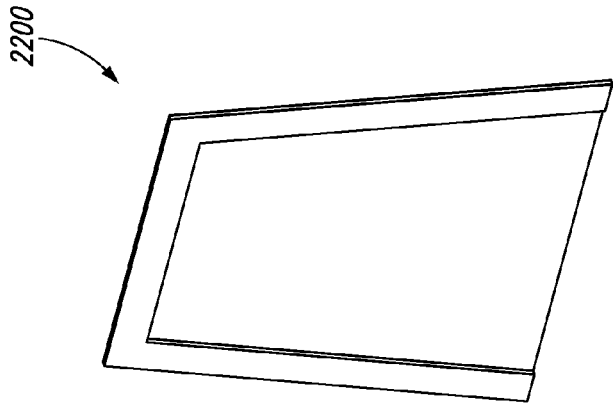

Fig. 22

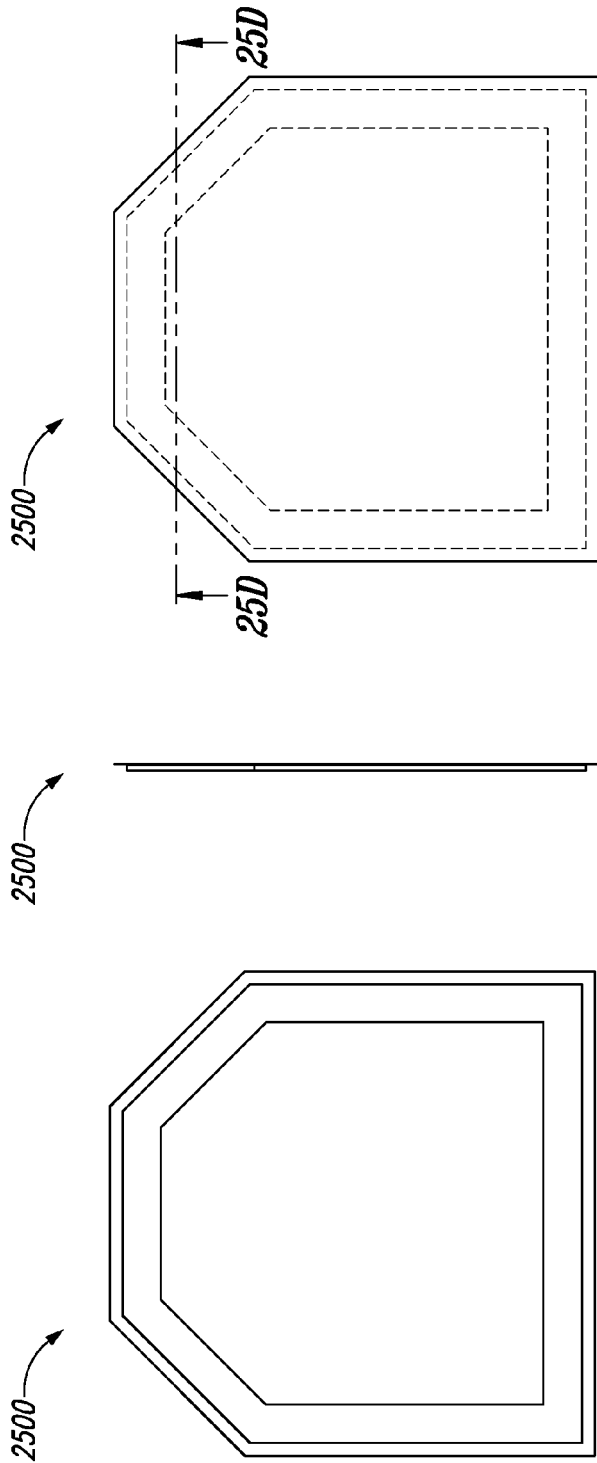

Fig. 25C

Fig. 25B

Fig. 25A

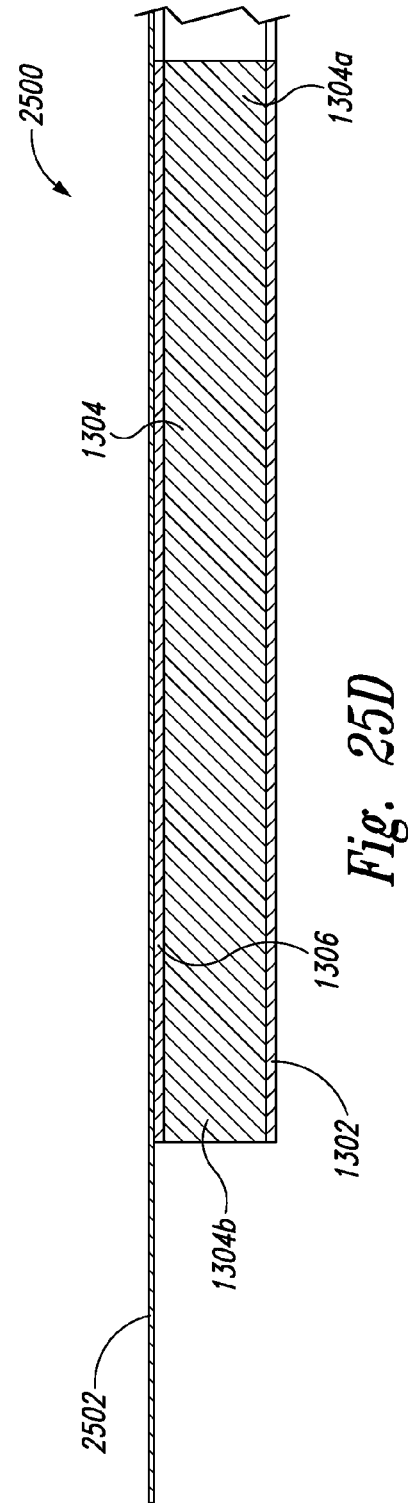

Fig. 25D

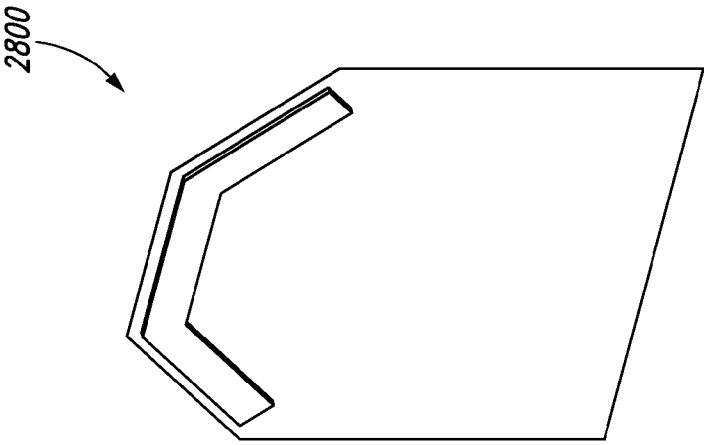

Fig. 26

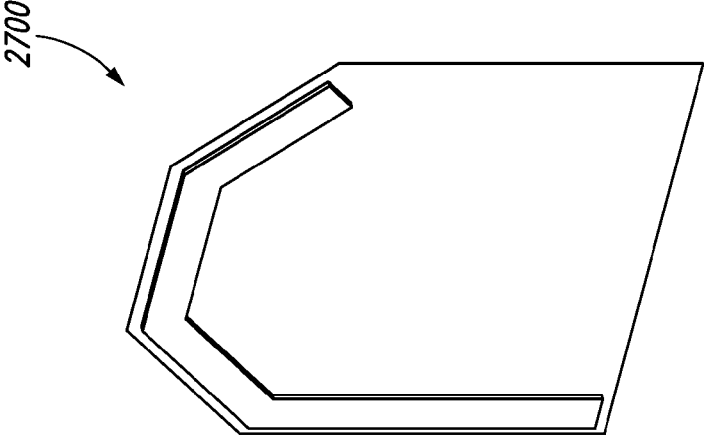

Fig. 27

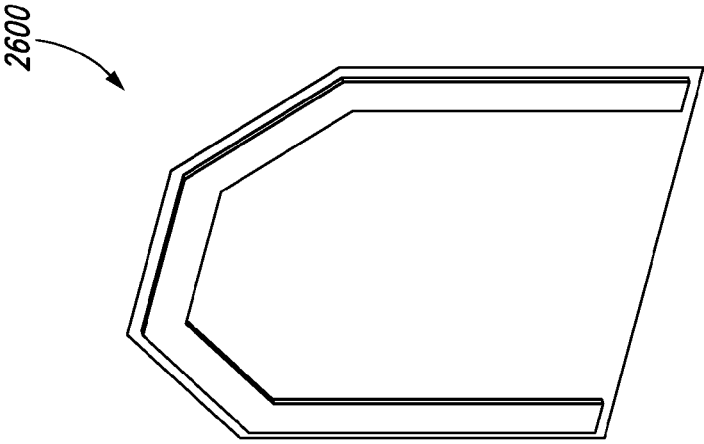

Fig. 28

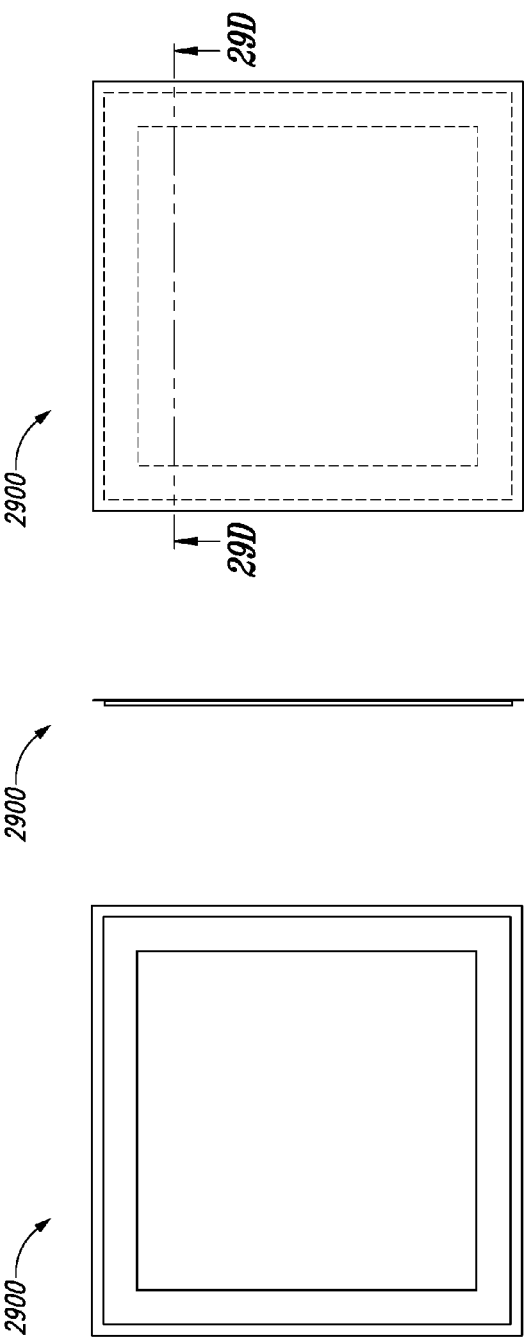

Fig. 29A Fig. 29B Fig. 29C

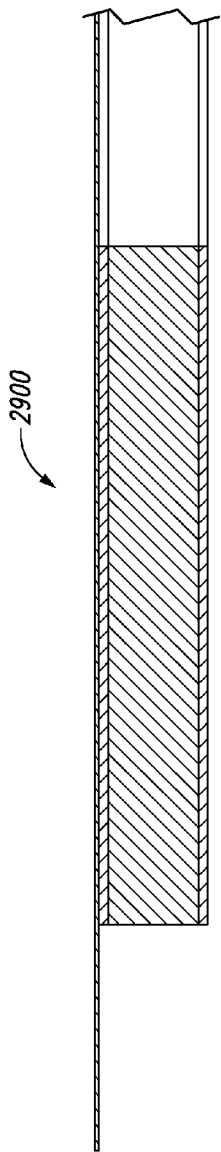

Fig. 29D

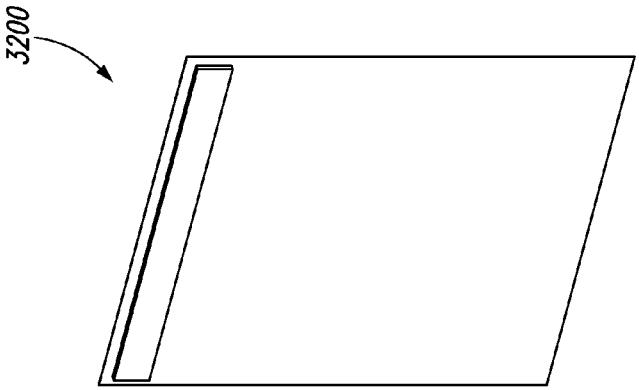

Fig. 32

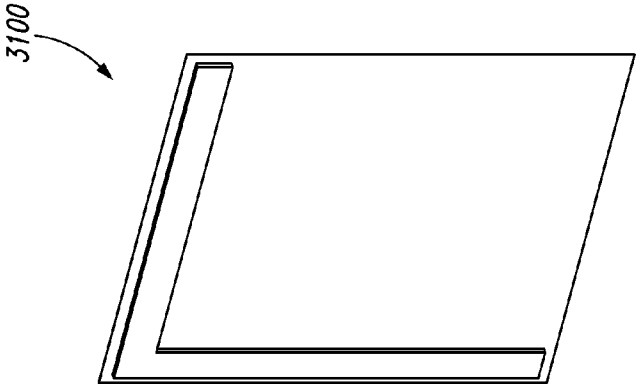

Fig. 31

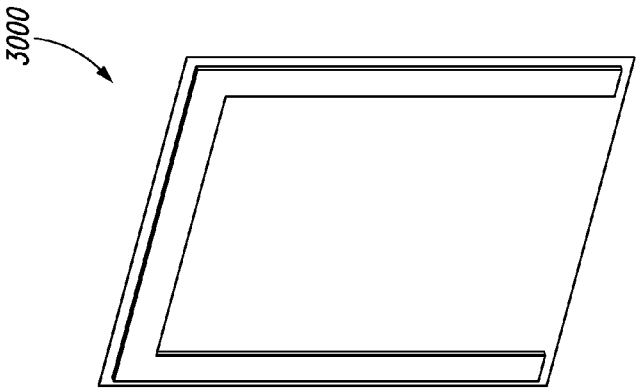

Fig. 30

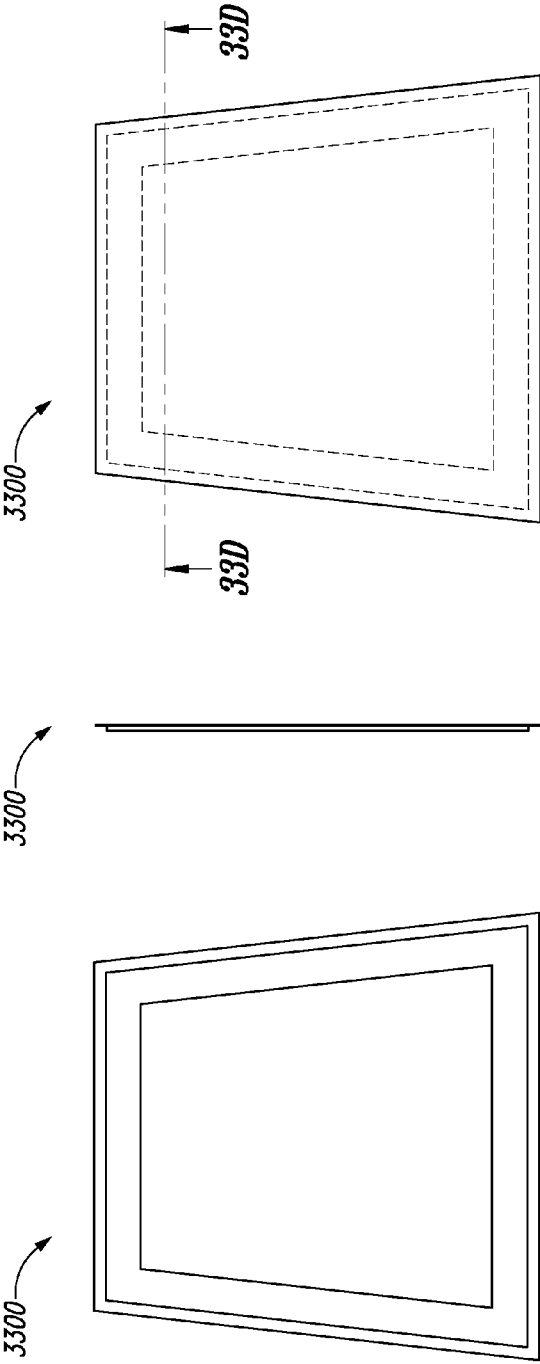

Fig. 33A

Fig. 33B

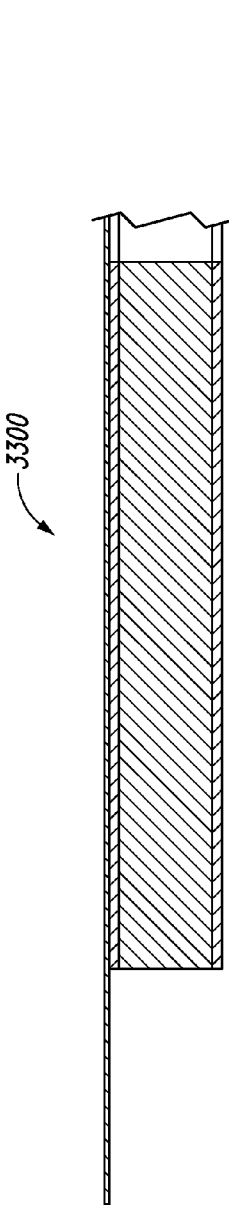

Fig. 33C

Fig. 33D

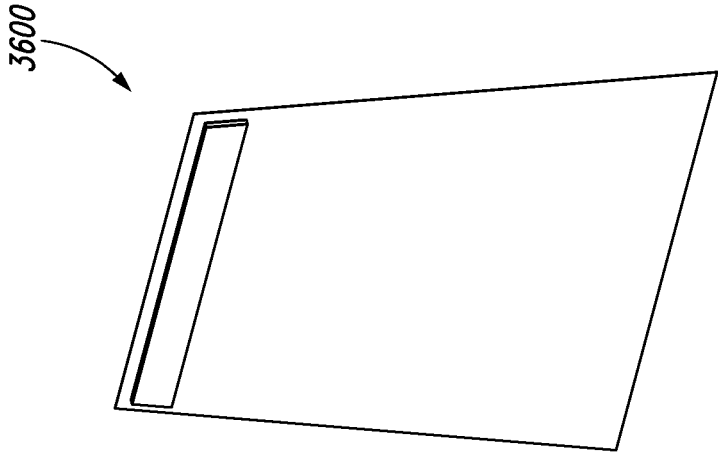

Fig. 36

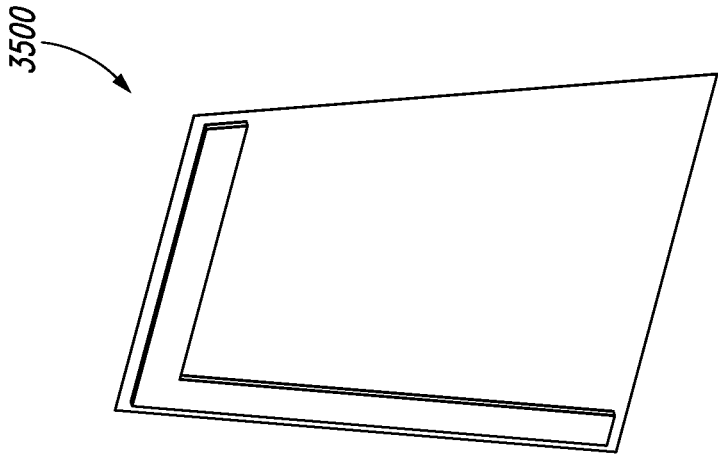

Fig. 35

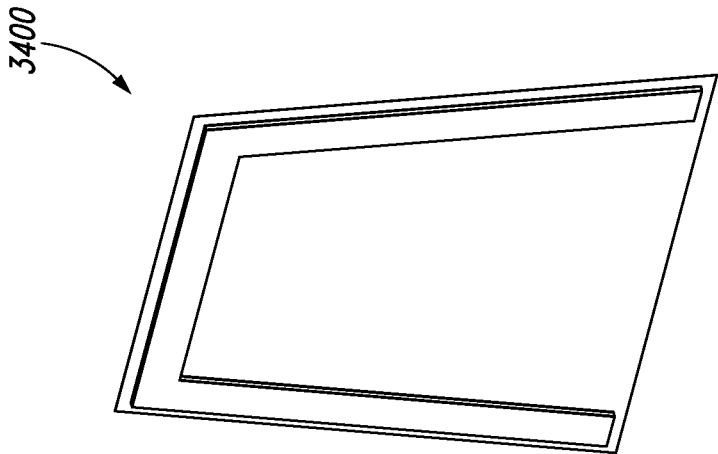

Fig. 34

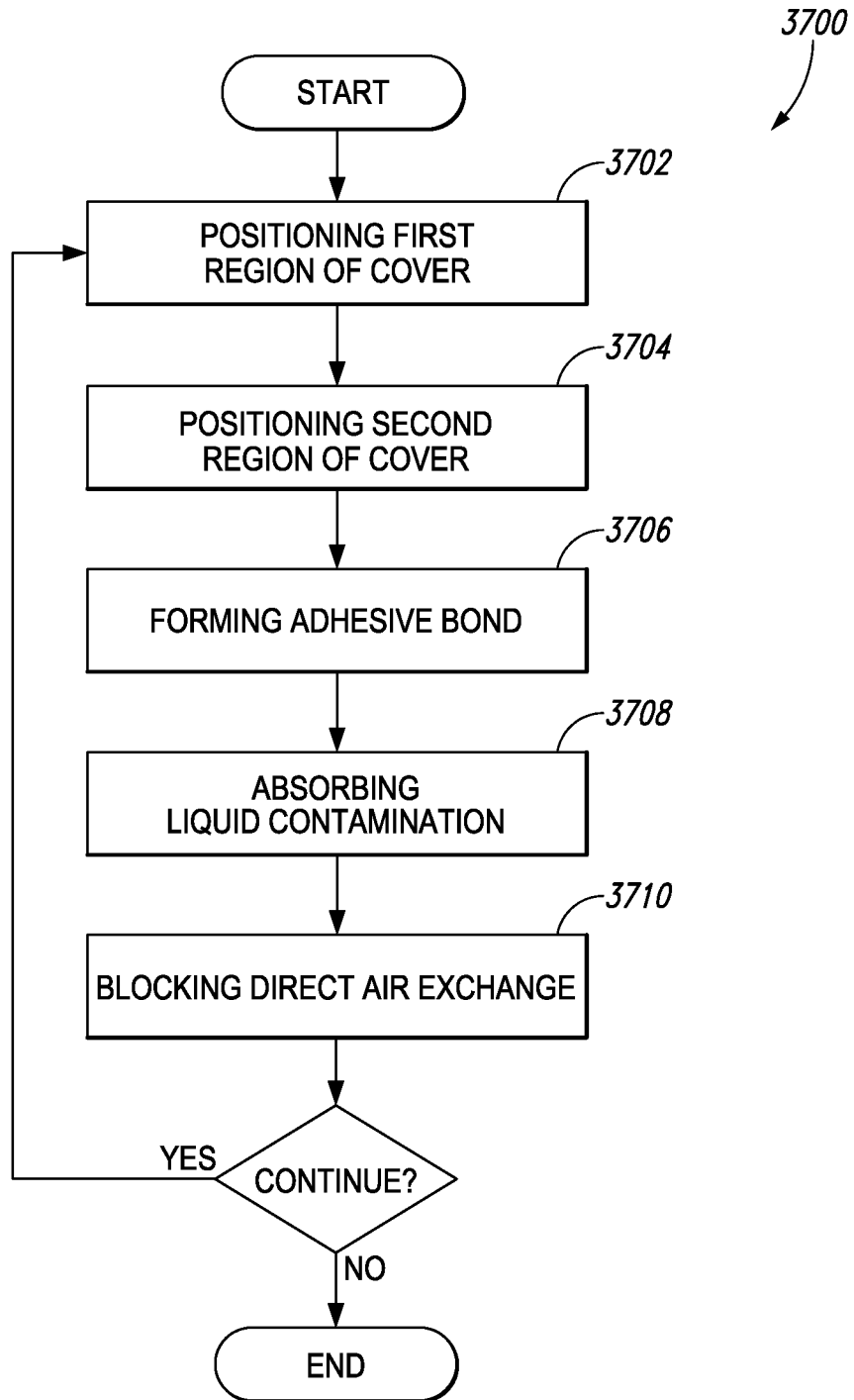

Fig. 37

**DEVICES FOR PROTECTING VULNERABLE
SITES ON PATIENTS FROM LIQUID
CONTAMINATION AND RELATED
DEVICES, SYSTEMS, AND METHODS**

**CROSS-REFERENCE TO RELATED
APPLICATIONS**

[0001] This application is a continuation of U.S. application Ser. No. 14/225,268, filed Mar. 25, 2014, which claims the benefit of the earlier filing date of U.S. Provisional Application No. 61/805,483, filed Mar. 26, 2013. The foregoing applications are incorporated herein by reference in their entireties.

TECHNICAL FIELD

[0002] The present technology is related to protective devices for medical applications. In particular, at least some embodiments are related to devices for protecting vulnerable sites (e.g., percutaneous sites) on patients from respiratory exudates and/or other types of liquid contamination.

BRIEF DESCRIPTION OF THE DRAWINGS

[0003] Many aspects of the present technology can be better understood with reference to the following drawings. The components in the drawings are not necessarily to scale. Instead, emphasis is placed on illustrating clearly the principles of the present technology. For ease of reference, throughout this disclosure identical reference numbers may be used to identify identical or at least generally similar or analogous components or features.

[0004] FIGS. 1A, 1B, and 1C are a front (i.e., skin-contact) side view, an edge view, and a back view, respectively, of a protective device configured in accordance with an embodiment of the present technology.

[0005] FIG. 1D is a cross-sectional end view of the protective device shown in FIGS. 1A-1C taken along the line 1D-1D in FIG. 1C in a non-deployed state.

[0006] FIG. 1E is a cross-sectional end view of the protective device shown in FIGS. 1A-1C taken along the line 1E-1E in FIG. 1C in a deployed state against a patient's skin.

[0007] FIGS. 2-4 are perspective views illustrating protective devices similar to the protective device of FIGS. 1A-1D, but having different suitable peripheral coverage of adhesive films and liquid-absorbing elements configured in accordance with embodiments of the present technology.

[0008] FIGS. 5A, 5B, and 5C are a front (i.e., skin-contact) side view, an edge view, and a back view, respectively, of a protective device configured in accordance with an embodiment of the present technology.

[0009] FIG. 5D is a cross-sectional end view of the protective device shown in FIGS. 5A-5C taken along the line 5D-5D in FIG. 5C.

[0010] FIGS. 6-8 are perspective views illustrating protective devices similar to the protective device of FIGS. 5A-5D, but having different suitable peripheral coverage of adhesive films and liquid-absorbing elements configured in accordance with embodiments of the present technology.

[0011] FIGS. 9A, 9B, and 9C are a front (i.e., skin-contact) side view, an edge view, and a back view, respectively, of a protective device configured in accordance with an embodiment of the present technology.

[0012] FIG. 9D is a cross-sectional end view of the protective device shown in FIGS. 9A-9C taken along the line 9D-9D in FIG. 9C.

[0013] FIGS. 10-12 are perspective views illustrating protective devices similar to the protective device of FIGS. 9A-9D, but having different suitable peripheral coverage of adhesive films and liquid-absorbing elements configured in accordance with embodiments of the present technology.

[0014] FIGS. 13A, 13B, and 13C are a front (i.e., skin-contact) side view, an edge view, and a back view, respectively, of a protective device configured in accordance with an embodiment of the present technology.

[0015] FIG. 13D is a cross-sectional end view of the protective device shown in FIGS. 13A-13C taken along the line 13D-13D in FIG. 13C.

[0016] FIGS. 14-16 are perspective views illustrating protective devices similar to the protective device of FIGS. 13A-13D, but having different suitable peripheral coverage of adhesive films and liquid-absorbing elements configured in accordance with embodiments of the present technology.

[0017] FIGS. 17A, 17B, and 17C are a front (i.e., skin-contact) side view, an edge view, and a back view, respectively, of a protective device configured in accordance with an embodiment of the present technology.

[0018] FIG. 17D is a cross-sectional end view of the protective device shown in FIGS. 17A-17C taken along the line 17D-17D in FIG. 17C.

[0019] FIGS. 18-20 are perspective views illustrating protective devices similar to the protective device of FIGS. 17A-17D, but having different suitable peripheral coverage of adhesive films and liquid-absorbing elements configured in accordance with embodiments of the present technology.

[0020] FIGS. 21A, 21B, and 21C are a front (i.e., skin-contact) side view, an edge view, and a back view, respectively, of a protective device configured in accordance with an embodiment of the present technology.

[0021] FIG. 21D is a cross-sectional end view of the protective device shown in FIGS. 21A-21C taken along the line 21D-21D in FIG. 21C.

[0022] FIGS. 22-24 are perspective views illustrating protective devices similar to the protective device of FIGS. 21A-21D, but having different suitable peripheral coverage of adhesive films and liquid-absorbing elements configured in accordance with embodiments of the present technology.

[0023] FIGS. 25A, 25B, and 25C are a front (i.e., skin-contact) side view, an edge view, and a back view, respectively, of a protective device configured in accordance with an embodiment of the present technology.

[0024] FIG. 25D is a cross-sectional end view of the protective device shown in FIGS. 25A-25C taken along the line 25D-25D in FIG. 25C.

[0025] FIGS. 26-28 are perspective views illustrating protective devices similar to the protective device of FIGS. 25A-25D, but having different suitable peripheral coverage of adhesive films and liquid-absorbing elements configured in accordance with embodiments of the present technology.

[0026] FIGS. 29A, 29B, and 29C are a front (i.e., skin-contact) side view, an edge view, and a back view, respectively, of a protective device configured in accordance with an embodiment of the present technology.

[0027] FIG. 29D is a cross-sectional end view of the protective device shown in FIGS. 29A-29C taken along the line 29D-29D in FIG. 29C.

[0028] FIGS. 30-32 are perspective views illustrating protective devices similar to the protective device of FIGS. 29A-29D, but having different suitable peripheral coverage of adhesive films and liquid-absorbing elements configured in accordance with embodiments of the present technology.

[0029] FIGS. 33A, 33B, and 33C are a front (i.e., skin-contact) side view, an edge view, and a back view, respectively, of a protective device configured in accordance with an embodiment of the present technology.

[0030] FIG. 33D is a cross-sectional end view of the protective device shown in FIGS. 33A-33C taken along the line 33D-33D in FIG. 33C.

[0031] FIGS. 34-36 are perspective views illustrating protective devices similar to the protective device of FIGS. 33A-33D, but having different suitable peripheral coverage of adhesive films and liquid-absorbing elements configured in accordance with embodiments of the present technology.

[0032] FIG. 37 is a flow chart illustrating a protective method 3700 in accordance with an embodiment of the present technology.

DETAILED DESCRIPTION

[0033] Specific details of several embodiments of the present technology are described herein with reference to FIGS. 1A-37. It should be noted that other embodiments in addition to those disclosed herein are within the scope of the present technology. For example, embodiments of the present technology can have different configurations, components, and/or procedures than those shown or described herein. Moreover, a person of ordinary skill in the art will understand that embodiments of the present technology can have configurations, components, and/or procedures in addition to those shown or described herein and that these and other embodiments can be without several of the configurations, components, and/or procedures shown or described herein without deviating from the present technology.

[0034] It is typically advantageous to maintain certain types of vulnerable sites at least generally free of liquid contamination. For example, it can be advantageous to prevent or reduce exposure of a percutaneous site or a wound to respiratory exudates and/or other types of liquid contamination that can cause an infection at the site. Since percutaneous sites, wounds, and other types of vulnerable sites may remain open and/or otherwise vulnerable for relatively long periods of time (e.g., many days, weeks, or longer), maintaining the sites at least generally free of liquid contamination can be challenging. As one example, a vulnerable site on a patient's neck or otherwise near a patient's head may be exposed to sputum, mucus, saliva, and/or other respiratory exudates and bodily secretions. As another example, a vulnerable site on a patient's torso or limb may be exposed to sweat, bathing runoff (e.g., from a sponge bath), spilled fluids, and/or other types of liquid contamination. Conventional dressings typically are ill suited for protecting vulnerable sites from liquid contamination. For example, many conventional dressings are designed primarily to reduce or prevent egress of liquid exudates (e.g., blood) from a wound, not to protect the wound from external sources of liquid contamination. To the extent that these and other conventional dressings may absorb liquid contamination, the absorbed liquid contamination typically is held in sustained contact with an adhesive and/or with the patient's skin. This can cause irritation, adhesive failure, and/or inadequate ventilation and/or have other undesirable conse-

quences. For example, enzymes in saliva can accelerate the breakdown of skin, thereby causing conventional dressings adhesively attached to skin to detach prematurely and/or contaminating a wound site.

[0035] Protective devices, systems, and methods configured in accordance with at least some embodiments of the present technology can at least partially overcome one or more of the disadvantages and technical challenges discussed above and/or one or more other disadvantages and/or technical challenges associated with conventional protective devices, systems, and methods. For example, a protective device configured in accordance with a particular embodiment includes a liquid-impermeable cover configured to extend over a vulnerable site on a patient and a liquid-absorbing element configured to absorb liquid contamination at and/or approaching an outer edge portion of an adhesive bond between the cover and the patient's skin. The liquid-absorbing element can hold the liquid contamination away from the vulnerable site and the cover can act as a complete or partial barrier to liquid contamination not held by the liquid-absorbing element. Furthermore, the liquid-absorbing element can help to protect the adhesive bond from degrading in the presence of liquid contamination. A variety of other advantages in addition to or instead of these advantages are also possible.

Selected Examples of Protective Devices

[0036] FIGS. 1A, 1B, and 1C are a front (i.e., skin-contact) side view, an edge view, and a back view, respectively, of a protective device 100 configured in accordance with an embodiment of the present technology. FIG. 1D is a cross-sectional end view of the protective device 100 taken along the line 1D-1D in FIG. 1C in a non-deployed state. FIG. 1E is a cross-sectional end view of the protective device 100 taken along the line 1E-1E in FIG. 1C in a deployed state against a patient's skin 101. With reference to FIGS. 1A-1E together, the protective device 100 can include a cover 102, an adhesive film 104, and a liquid-absorbing element 106. The cover 102 can have a first (e.g., central) region 102a and a second (e.g., peripheral) region 102b extending around a perimeter of the first region 102a. The cover 102 can be configured to be operably positioned on a human patient such that the first region 102a extends over a vulnerable site (not shown) on the patient and the second region 102b extends over an area on the patient peripheral to the vulnerable site. In some embodiments, the cover 102 is flexible and configured to drape over a vulnerable site, such as to accommodate the dimensionality of a percutaneous device (e.g., a peripheral cannula extending into a patient's vasculature). For example, the first region 102a can be a region of a sheet of flexible polymeric material, such as flexible polyurethane, flexible polyethylene, or another suitable flexible polymeric material. In other embodiments, the cover 102 can be less flexible. For example, the first region 102a can be a region of a three-dimensional shell that is at least generally rigid and configured to at least partially encase a three-dimensional space adjacent to a vulnerable site. Furthermore, the first region 102a can be opaque, transparent (e.g., to allow a vulnerable site or a percutaneous device at a vulnerable site to be visually monitored), or otherwise translucent.

[0037] The protective device 100 can be configured to protect the vulnerable site from liquid (e.g., non-aerosolized liquid and aerosolized liquid) and particulate contamination.

For example, the first region **102a**, the second region **102b**, or both can be at least generally impermeable to liquid water. In a particular example, the protective device **100** protects a percutaneous device (not shown) that is positioned at least proximate to a patient's neck and the protective device **100** reduces the probability that an infection will develop at the vulnerable site by protecting the vulnerable site from respiratory exudates (e.g., sputum, mucus, and/or saliva) and other sources of contamination. In other examples, the protective device **100** can be used at other suitable anatomical locations. Furthermore, the protective device **100** can be used to protect a vulnerable site that does not include a percutaneous device, such as a dressed wound, an undressed wound, or a stoma without an associated percutaneous device. Still further, the protective device **100** can be used to protect a vulnerable site from liquid contamination other than respiratory exudates, such as sweat, bathing runoff, or spilled liquids. Still further, in addition to or instead of reducing the probability that an infection will develop at a vulnerable site, the protective device **100** can address a different type of vulnerability, such as susceptibility to shifting of a percutaneous device relative to a patient, susceptibility to inadvertent scratching, or another suitable type of vulnerability.

[0038] When operably positioned on a patient, the cover **102** and components of the cover **102** individually can have first side **102c** facing toward the patient and a second side **102d** facing away from the patient. Furthermore, the cover **102** can have an outer edge portion **102e** extending between the first and second sides **102c**, **102d**. The adhesive film **104** can be attached to the cover **102** directly or indirectly and can have an inner edge portion **104a** toward the first region **102a** and an outer edge portion **104b** away from the first region **102a**. For example, the adhesive film **104** can be disposed along the first side **102c** of the second region **102b** of the cover **102**. The adhesive film **104** can be configured to form an adhesive bond **107** (FIG. 1E) between the second region **102b** and the patient's skin **101**. The bond **107** can have an inner edge portion **107a** positioned toward a vulnerable site and an outer edge portion **107b** positioned away from the vulnerable site.

[0039] The bond **107** can be a direct bond between the second region **102b** and the patient or an indirect bond. Furthermore, in some embodiments, the outer edge portion **107b** of the bond **107** is aligned with the outer edge portion **102e** of the cover **102**. In other embodiments, the outer edge portion **107b** of the bond **107** can be inset (e.g., toward the vulnerable site) relative to the outer edge portion **102e** of the cover **102**. For example, the adhesive film **104** can be configured such that the outer edge portion **102e** of the cover **102** is positioned at least about 0.5 centimeter or at least another suitable distance further from the vulnerable site than the outer edge portion **107b** of the bond **107** when the cover **102** is operably positioned on a patient. In some embodiments, the bond **107** at least generally blocks direct air exchange between the vulnerable site and the liquid-absorbing element **106**. This can be useful, for example, to enhance separation between the vulnerable site and liquid contaminants within the liquid-absorbing element **106**. In other embodiments, the vulnerable site can be open to air exchange with the liquid-absorbing element **106**. For example, the bond **107** can be between the liquid-absorbing element **106** and the patient's skin **101** and the cover **102** can

be attached to the patient via both the liquid-absorbing element **106** and the bond **107** rather than via the bond **107** only.

[0040] The adhesive film **104** can extend around all or a portion of the perimeter of the first region **102a**. In some embodiments, the cover **102** includes a third region (not shown) at a portion of the perimeter of the first region **102a** along which the adhesive film **104** does not extend. For example, the adhesive film **104** can extend around a percentage of the perimeter of the first region **102a** of the cover **102** from about 5% to about 95%, from about 10% to about 95%, from about 15% to about 95%, or within another suitable range. The third region can be configured to allow ventilation of a vulnerable site when the cover **102** is operably positioned on a patient. Such ventilation, for example, can reduce or prevent undue condensation on the first side **102c** of the cover **102** even when the first region **102a** of the cover **102** is impermeable to water vapor. In other embodiments, the adhesive film **104** can extend around the entire perimeter of the first region **102a**. In these and other embodiments, the first region **102a** of the cover **102** can be permeable to water vapor, the cover **102** can be configured to allow ventilation in another suitable manner, or the cover **102** can be configured to leave a vulnerable site unventilated. In a particular example of ventilation, the cover **102**, the adhesive film **104**, or another suitable component of the device **100** includes an active or passive vent (not shown), such as a perforation, a fenestration, a filtered opening, or a baffled opening. The vent, for example, can be configured to allow water vapor to escape from the vulnerable site without unduly interfering with the ability of the cover **102** to exclude liquid contamination from the vulnerable site.

[0041] The liquid-absorbing element **106** can be attached to the cover **102** directly or indirectly. In some embodiments, at least a portion of the liquid-absorbing element **106** is disposed along the second side **102d** of the cover **102** (e.g., along the second side **102d** of the second region **102b** of the cover **102**) such that the cover **102** is positioned between at least a portion of the liquid-absorbing element **106** and a patient when the cover **102** is operably positioned on the patient. In other embodiments, the liquid-absorbing element **106** can be disposed along the first side **102c** of the cover **102**, such that at least a portion of the liquid-absorbing element **106** is positioned between the cover **102** and a patient when the cover **102** is operably positioned on the patient. In still other embodiments, the liquid-absorbing element **106** can be disposed partially along the first side **102c** of the cover **102** and partially along the second side **102d** of the cover **102**. The position of the liquid-absorbing element **106** relative to the cover **102** can affect how liquid contamination within the liquid-absorbing element **106** is held. For example, positioning the liquid-absorbing element **106** between the cover **102** and the patient can, in at least some cases, enhance separation between the liquid contamination and the bond **107**. Alternatively, positioning the cover **102** between the liquid-absorbing element **106** and the patient can, in at least some cases, enhance separation between the liquid contamination and the patient's skin **101** and/or accelerate evaporation of the liquid contamination, such as by exposing a relatively large portion of the liquid-absorbing element **106** to the atmosphere.

[0042] The liquid-absorbing element **106** can be configured to absorb liquid contamination at the outer edge portion

107b of the bond **107** and/or liquid contamination approaching the outer edge portion **107b** of the bond **107** when the cover **102** is operably positioned on a patient. For example, the liquid-absorbing element **106** can be configured to wick liquid contamination away from the outer edge portion **107b** of the bond **107**. The liquid-absorbing element **106** can have an inner edge portion **106a** positioned toward the bond **107** and an outer edge portion **106b** positioned away from the bond **107**. As shown in FIGS. 1A-1E, at least a portion of the liquid-absorbing element **106** can be positioned further from the vulnerable site than the outer edge portion **107b** of the bond **107** when the cover **102** is operably positioned on the patient. Furthermore, in some embodiments, the outer edge portion **102e** of the cover **102** can be positioned closer to the vulnerable site than the outer edge portion **106b** of the liquid-absorbing element **106**. In other embodiments, the outer edge portion **102e** of the cover **102** can be positioned further from the vulnerable site than the outer edge portion **106b** of the liquid-absorbing element **106**. For example, the outer edge portion **102e** of the cover **102** can be configured to drape over the outer edge portion **106b** of the liquid-absorbing element **106** when the cover **102** is operably positioned on the patient.

[0043] The liquid-absorbing element **106** can be an elongate strip of absorbent material or have another suitable form. The liquid-absorbing element **106** can have an average dimension (e.g., thickness) perpendicular to an associated skin surface greater than about 2 millimeters (e.g., from about 2 millimeters to about 50 millimeters), greater than about 5 millimeters (e.g., from about 5 millimeters to about 50 millimeters), greater than about 10 millimeters (e.g., from about 10 millimeters to about 50 millimeters), greater than another suitable threshold or within another suitable range. Suitable materials and material classes for the liquid-absorbing element **106** include, for example, porous media (e.g., fabrics and open-cell foams), polymers (e.g., polyvinyl alcohol), hydrophilic polymers, and desiccants, among others. In some embodiments, the liquid-absorbing element **106** is capable of absorbing at least about five times (e.g., from about 5 times to about 100 times) its weight in liquid water, such as at least about 10 times (e.g., from about 10 times to about 100 times) its weight in liquid water. In other embodiments, the liquid-absorbing element **106** can have other suitable absorbent properties. Furthermore, the liquid-absorbing element **106** can include an antimicrobial agent (e.g., colloidal silver), which can add another layer of protection against infection.

[0044] FIGS. 2, 3 and 4 are perspective views illustrating, respectively, protective devices **200**, **300** and **400** that are similar to the protective device **100**, but have different suitable peripheral coverage of adhesive films and liquid-absorbing elements. FIGS. 5A-5D illustrate a protective device **500** similar to the protective device **100**, but having a different suitable shape. FIGS. 6, 7 and 8 are perspective views illustrating, respectively, protective devices **600**, **700** and **800** that are similar to the protective device **500**, but have different suitable peripheral coverage of adhesive films and liquid-absorbing elements. FIGS. 9A-9D illustrate a protective device **900** similar to the protective device **100**, but having a different suitable shape. FIGS. 10, 11 and 12 are perspective views illustrating, respectively, protective devices **1000**, **1100** and **1200** that are similar to the protective device **900**, but have different suitable peripheral coverage of adhesive films and liquid-absorbing elements. A

variety of other suitable shapes and peripheral coverage are also possible. For example, different shapes can be selected based on anatomical differences among patients, different characteristics of different types of vulnerable sites to be protected, and/or different dimensions of percutaneous devices. The peripheral coverage can be selected, for example, based on these factors alone or together with different demands for ventilation and/or different demands for accessibility of vulnerable sites.

[0045] FIGS. 13A-13D illustrate a protective device **1300** similar to the protective device **100**, but having a first adhesive film **1302** configured to be positioned between a liquid-absorbing element **1304** and a patient (not shown) as well as a second adhesive film **1306** positioned between the liquid-absorbing element **1304** and an associated cover. The liquid-absorbing element **1304** can have an inner edge portion **1304a** toward a vulnerable site (not shown) and an outer edge portion **1304b** away from the vulnerable site. FIGS. 14, 15 and 16 are perspective views illustrating, respectively, protective devices **1400**, **1500** and **1600** that are similar to the protective device **1300**, but have different suitable peripheral coverage of adhesive films and liquid-absorbing elements. FIGS. 17A-17D illustrate a protective device **1700** similar to the protective device **1300**, but having a different suitable shape. FIGS. 18, 19 and 20 are perspective views illustrating, respectively, protective devices **1800**, **1900** and **2000** that are similar to the protective device **1700**, but have different suitable peripheral coverage of adhesive films and liquid-absorbing elements. FIGS. 21A-21D illustrate a protective device **2100** similar to the protective device **1300**, but having a different suitable shape. FIGS. 22, 23 and 24 are perspective views illustrating, respectively, protective devices **2200**, **2300** and **2400** that are similar to the protective device **2100**, but have different suitable peripheral coverage of adhesive films and liquid-absorbing elements.

[0046] FIGS. 25A-25D illustrate a protective device **2500** similar to the protective device **1300**, but having the first adhesive film **1302**, the liquid-absorbing element **1304**, and the second adhesive film **1306** inset relative to the outer edge portion **102e** of the cover **102** such that a flap **2502** extends over the outer edge portion **1304b** of the liquid-absorbing element **1304**. FIGS. 26, 27 and 28 are perspective views illustrating, respectively, protective devices **2600**, **2700** and **2800** that are similar to the protective device **2500**, but have different suitable peripheral coverage of adhesive films and liquid-absorbing elements. FIGS. 29A-29D illustrate a protective device **2900** similar to the protective device **2500**, but having a different suitable shape. FIGS. 30, 31 and 32 are perspective views illustrating, respectively, protective devices **3000**, **3100** and **3200** that are similar to the protective device **2900**, but have different suitable peripheral coverage of adhesive films and liquid-absorbing elements. FIGS. 33A-33D illustrate a protective device **3300** similar to the protective device **2500**, but having a different suitable shape. FIGS. 34, 35 and 36 are perspective views illustrating, respectively, protective devices **3400**, **3500** and **3600** that are similar to the protective device **3300**, but have different suitable peripheral coverage of adhesive films and liquid-absorbing elements.

Selected Examples of Protective Methods

[0047] FIG. 37 is a flow chart illustrating a protective method **3700** in accordance with an embodiment of the

present technology. With reference to FIGS. 1A-1E and 37 together, the method 3700 can include positioning the first region 102a of the cover 102 over a vulnerable site on a human patient (block 3702) and positioning the second region 102b of the cover 102 between the vulnerable site and an actual or potential source of liquid contamination (block 3704). For example, the vulnerable site can be at least proximate to the patient's neck and the second region 102b of the cover 102 can be positioned between the vulnerable site and the patient's mouth and/or nose. The method 3700 can further include forming the adhesive bond 107 between the second region 102b of the cover 102 and the patient (block 3706). In some embodiments, this includes forming the bond 107 around the entire perimeter of the first region 102a of the cover 102. In other embodiments, this can include forming the bond 107 around a suitable percentage of a perimeter of the first region 102a of the cover 102, such as from about 10% to about 90% of the perimeter of the first region 102a of the cover 102.

[0048] Next, the method 3700 can include absorbing liquid contamination (e.g., respiratory exudates from the patient's mouth and/or nose) at the outer edge portion 107b of the bond 107 and/or liquid contamination approaching the outer edge portion 107b of the bond 107 using the liquid-absorbing element 106 (block 3708). For example, the method 3700 can include wicking liquid contamination away from the outer edge portion 107b of the bond 107 and into the liquid-absorbing element 106. In some embodiments, the liquid contamination is absorbed via an outwardly projecting portion of the liquid-absorbing element 106 positioned further from the vulnerable site than the outer edge portion 107b of the bond 107. After the liquid-absorbing element 106 absorbs the liquid contamination, the method 3700 can include at least generally blocking direct exchange between air in contact with the vulnerable site at one side of the bond 107 and air in contact with liquid contamination within the liquid-absorbing element 106 at an opposite side of the bond 107 (block 3710).

[0049] The method 3700 can also include other suitable operations. As an example, the method 3700 can include loosely positioning the first region 102a of the cover 102 over a percutaneous device at the vulnerable site. In addition or alternatively, the method 3700 can include tightly positioning the first region 102a of the cover 102 over a percutaneous device at the vulnerable site, such as to at least partially secure a position of the percutaneous device relative to the patient. As another example, the method 3700 can include visually monitoring the vulnerable site through the first region 102a of the cover 102. As another example, the method 3700 can include moving the first region 102a of the cover 102 to at least partially expose the vulnerable site without disrupting the bond 107. As another example, the method 3700 can include at least generally blocking direct contact between liquid contamination within the liquid-absorbing element 106 at one side of the cover 102 and the patient at an opposite side of the cover 102, such as when the liquid-absorbing element 106 is disposed along the second side 102d of the second region 102b of the cover 102. As another example, the method 3700 can include ventilating the vulnerable site through a gap between the patient and a third region of the cover 102 at a portion of the perimeter of the first region 102a of the cover 102 around which the bond 107 is not formed.

CONCLUSION

[0050] This disclosure is not intended to be exhaustive or to limit the present technology to the precise forms disclosed

herein. Although specific embodiments are disclosed herein for illustrative purposes, various equivalent modifications are possible without deviating from the present technology, as those of ordinary skill in the relevant art will recognize. In some cases, well-known structures and functions have not been shown or described in detail to avoid unnecessarily obscuring the description of embodiments of the present technology. Although steps of methods may be presented herein in a particular order, in alternative embodiments the steps may have other suitable orders. Similarly, certain aspects of the present technology disclosed in the context of particular embodiments can be combined or eliminated in other embodiments. Furthermore, while advantages associated with certain embodiments may have been disclosed in the context of those embodiments, other embodiments can also exhibit such advantages, and not all embodiments need necessarily exhibit such advantages or other advantages disclosed herein to fall within the scope of the present technology. Accordingly, this disclosure and associated technology can encompass other embodiments not expressly shown or described herein.

[0051] The methods disclosed herein include and encompass, in addition to methods of practicing the present technology (e.g., methods of making and using the disclosed devices and systems), methods of instructing others to practice the present technology. For example, a method in accordance with a particular embodiment includes positioning a first region of a cover over a vulnerable site on a human patient, positioning a second region of the cover between the vulnerable site and an actual or potential source of liquid contamination, forming an adhesive bond between the second region of the cover and the patient, absorbing liquid contamination at an outer edge portion of the bond and/or liquid contamination approaching the outer edge portion of the bond using a liquid-absorbing element attached to the cover, and at least generally blocking direct exchange between air in contact with the vulnerable site at one side of the bond and air in contact with liquid contamination within the liquid-absorbing element at an opposite side of the bond. A method in accordance with another embodiment includes instructing such a method.

[0052] Throughout this disclosure, the singular terms "a," "an," and "the" include plural referents unless the context clearly indicates otherwise. Similarly, unless the word "or" is expressly limited to mean only a single item exclusive from the other items in reference to a list of two or more items, then the use of "or" in such a list is to be interpreted as including (a) any single item in the list, (b) all of the items in the list, or (c) any combination of the items in the list. Additionally, the terms "comprising" and the like are used throughout this disclosure to mean including at least the recited feature(s) such that any greater number of the same feature(s) and/or one or more additional types of features are not precluded. Directional terms, such as "upper," "lower," "front," "back," "vertical," and "horizontal," may be used herein to express and clarify the relationship between various elements. It should be understood that such terms do not denote absolute orientation. Reference herein to "one embodiment," "an embodiment," or similar formulations means that a particular feature, structure, operation, or characteristic described in connection with the embodiment can be included in at least one embodiment of the present technology. Thus, the appearances of such phrases or formulations herein are not necessarily all referring to the same embodiment. Furthermore, various particular features, structures, operations, or characteristics may be combined in any suitable manner in one or more embodiments.

I/We claim:

1. A protective device, comprising:
 - a cover configured to be operably positioned on a human patient such that a first region of the cover extends over a vulnerable site on the patient and a second region of the cover extends over an area on the patient peripheral to the vulnerable site, the first region of the cover being at least generally impermeable to liquid water;
 - an adhesive film configured to form an adhesive bond between the second region of the cover and the patient, the bond having an inner edge portion positioned toward the vulnerable site and an outer edge portion positioned away from the vulnerable site when the cover is operably positioned on the patient; and
 - a liquid-absorbing element attached to the cover and configured to absorb liquid contamination at the outer edge portion of the bond and/or liquid contamination approaching the outer edge portion of the bond when the cover is operably positioned on the patient, at least a portion of the liquid-absorbing element being positioned further from the vulnerable site than the outer edge portion of the bond when the cover is operably positioned on the patient.
2. The protective device of claim 1 wherein the second region of the cover is at least generally impermeable to liquid water.
3. The protective device of claim 1 wherein the bond is a direct bond between the second region of the cover and the patient.
4. The protective device of claim 1 wherein the liquid-absorbing element is configured to wick liquid contamination away from the outer edge portion of the bond.
5. The protective device of claim 1 wherein the first region of the cover is permeable to water vapor.
6. The protective device of claim 1 wherein the first region of the cover is impermeable to water vapor.
7. The protective device of claim 1 wherein the first region of the cover is a region of a three-dimensional shell configured to at least partially encase a three-dimensional space adjacent to the vulnerable site when the cover is operably positioned on the patient.
8. The protective device of claim 1 wherein the liquid-absorbing element includes an antimicrobial agent.
9. The protective device of claim 1 wherein:
 - the adhesive film extends around from about 10% to about 90% of a perimeter of the first region of the cover; and
 - the cover includes a third region at a portion of the perimeter of the first region of the cover along which the adhesive film does not extend, the third region being configured to allow ventilation of the vulnerable site when the cover is operably positioned on the patient.
10. The protective device of claim 1 wherein the cover is flexible and configured to drape over a percutaneous device at the vulnerable site when the cover is operably positioned on the patient.
11. A protective device, comprising:
 - a cover configured to be operably positioned on a human patient such that a first region of the cover extends over a vulnerable site on the patient, a second region of the cover extends over an area on the patient peripheral to the vulnerable site, a first side of the second region of the cover faces toward the patient, and a second side of the second region of the cover faces away from the patient, the first region of the cover being at least generally impermeable to liquid water;
 - an adhesive film disposed along the first side of the second region of the cover, the adhesive film being configured to form an adhesive bond between the second region of the cover and the patient, the bond having an inner edge portion positioned toward the vulnerable site and an outer edge portion positioned away from the vulnerable site when the cover is operably positioned on the patient; and
 - a liquid-absorbing element disposed along the second side of the second region of the cover and configured to absorb liquid contamination at the outer edge portion of the bond and/or liquid contamination approaching the outer edge portion of the bond when the cover is operably positioned on the patient.
12. The protective device of claim 11 wherein the second region of the cover is at least generally impermeable to liquid water.
13. The protective device of claim 11 wherein the bond is a direct bond between the second region of the cover and the patient.
14. The protective device of claim 11 wherein the liquid-absorbing element is configured to wick liquid contamination away from the outer edge portion of the bond.
15. The protective device of claim 11 wherein the first region of the cover is permeable to water vapor.
16. The protective device of claim 11 wherein the first region of the cover is impermeable to water vapor.
17. The protective device of claim 11 wherein the first region of the cover is a region of a three-dimensional shell configured to at least partially encase a three-dimensional space adjacent to the vulnerable site when the cover is operably positioned on the patient.
18. The protective device of claim 11 wherein the liquid-absorbing element includes an antimicrobial agent.
19. The protective device of claim 11 wherein:
 - the adhesive film extends around from about 10% to about 90% of a perimeter of the first region of the cover; and
 - the cover includes a third region at a portion of the perimeter of the first region of the cover along which the adhesive film does not extend, the third region being configured to allow ventilation of the vulnerable site when the cover is operably positioned on the patient.
20. The protective device of claim 11 wherein the cover is flexible and configured to drape over a percutaneous device at the vulnerable site when the cover is operably positioned on the patient.

* * * * *