

(19) (KR)
(12) (B1)

(51) 。 Int. Cl.⁷
H05B 33/26

(45)
(11)
(24)

2005 01 13
10-0466399
2005 01 05

(21) 10-2000-0086088
(22) 2000 12 29

(65)
(43)

10-2002-0056686
2002 07 10

(73)

167-1

(72)

248 40 3 6-512

6 1 121 305

481-1 101-702

441-1 110 1301

(74)

:

(54)

IPE EL , 가 IPE EL
.
, IPE ITO
가 . ,
ITO 가 ,
가 .

1 EL
 2 , EL
 3 EL
 4 IPE
 5a, 5b, 5c, 5d IPE EL
 6 EL
 7 IPE EL
 *
 2: EL , 4,4':
 6,6': , 8,8':
 10: , 12:
 14: , 16:
 18: , 18a:
 20: , 20a:
 22: , 24:
 26: , 28:

IPE EL , IPE EL
 (Car Navigation System),
 , TV EL
 1 EL (2) 가 가 (4) (6) (8)
 EL EL (2) 가 가 EL EL
 EL (8) (Spin Coating)
 EL (8) ITO(Indum tin Oxide) (4) (Stripe)
 (8) 2 3 (6)
 10 (Spin Coating) EL
 2 , ITO(Indum Tin Oxide) (4') (8') EL (Shadow Mask: 14)
 (8') EL (16) (8') (14) (16)
 (Metal Source)
 EL (14) (14)
 (Taper) (14)
 (Stripe) (14) (14)
 가 (14) (Metal Line) , (Align) 가
 EL (PR) 가 EL (8')
 (14)

가 EL 가 가 EL ,
 , 가 가 (14) (16)
 가 (Passive Matrix) EL (4')
 PDA, Car-Display 가 가 (4')
 , 가 IPE
 EL
 , ITO IPE EL 가
 , EL 가
 , 가
 , μm ,
 , PPV, MEH-PPV, Polythiophene, Polypyrrole, OC₁C₁₀
 , IPE EL 가
 ,
 3 EL (18) (20) (22) EL (19) (18, 20) (+) ()
 -)가 (22) (18, 20) EL (Solvent)
 , EL 가
 4 IPE (24)
 (, IPE: In Plane Electrode) (10) (18) (20)
 가 (18, 20)
 , (18, 20) (22) (18, 20)
 ,
 4 IPE (4, 6)
 (8) (18, 20) (22)
 , (18) 가 ITO(Indum Tin Oxide)
 5a, 5b, 5c, 5d IPE 가 EL 가
 EL EL 7 6
 PE EL

5a (18) ITO 가

5a (18) (18) ITO

EL IPE 가 (18) ITO

가 (Stripe) IPE 5a (18) IPE (18a)

(Wet Etch) (Profile) 가 (20a) (18a) (Dry Etch)

(20a)

5b (18) (26) 가 (26) (26)

) (18) μm EL (20) (18a)

5c IPE (10) (20) (18) (20a) (18a)

(Dry etch) (20a) (18a) 가 (18a)

IPE EL (18) (20) ITO 가 IP

E EL (array) 5d 가 (Solve)

nt) PPV, MEH-PPV, Polythiophene, Polypyrrole, OC₁C₁₀

(Spin coating) (Inkjet Printing)

EL (18) (20) (22) 2000 가 가

IPE (20a) (18a, 20a) (18a) ITO가 가

5d IPE EL 가

(18a) EL (20a) (20) (22)

IPE (Full color panel) (18a, 20a) 6a 6b

(18a, 20a)

ITO 가

가 IPE 가

EL 가 (Array) (Array) EL

IPE EL 가

, IPE EL IPE ITO
 가
 , ITO 가 ,
 가 .

(57)

1.

IPE

EL

2.

1
PE

ITO

가

EL

3.

1

IPE

EL

4.

1

EL

IPE

EL

가

5.

1

가

IPE

EL

6.

1

IPE

EL

7.

3

μm

IPE

EL

8.

9.

1

, PPV, MEH-PPV, Polythiophene, Polypyrrole, OC₁C₁₀

IPE

EL

10.

1

IPE

EL

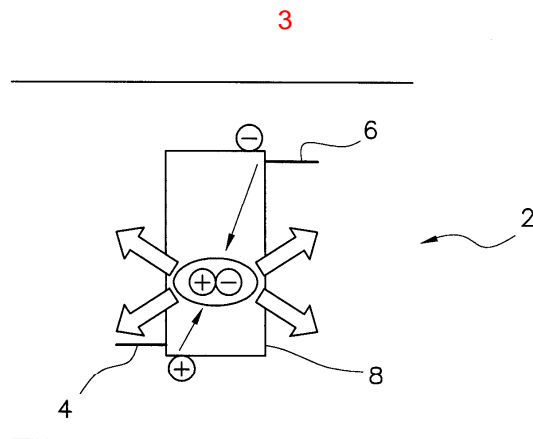
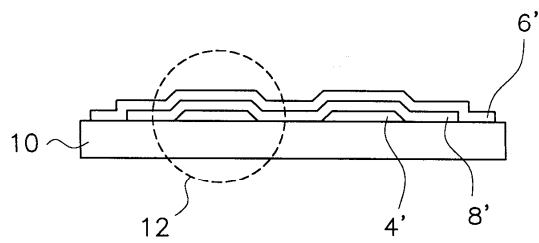
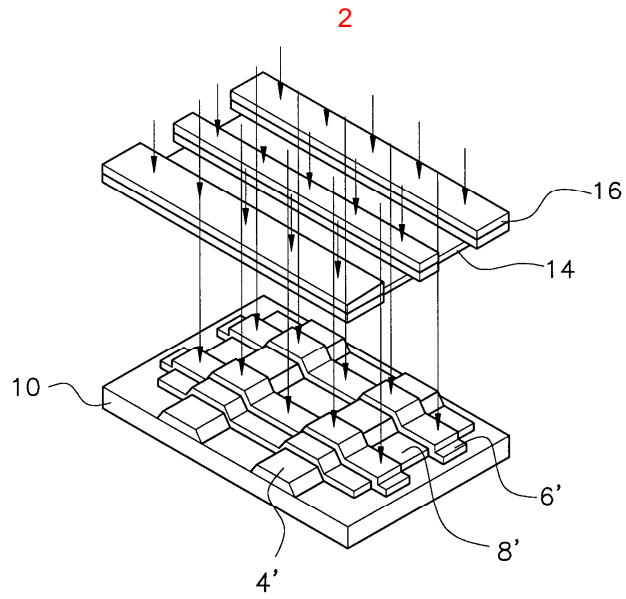
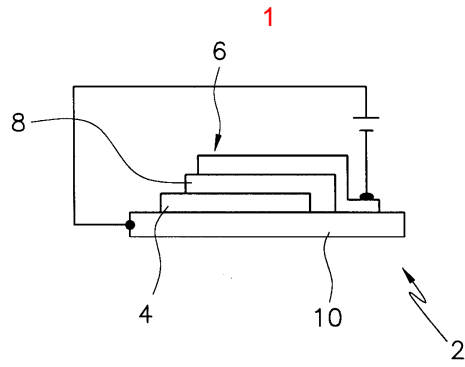

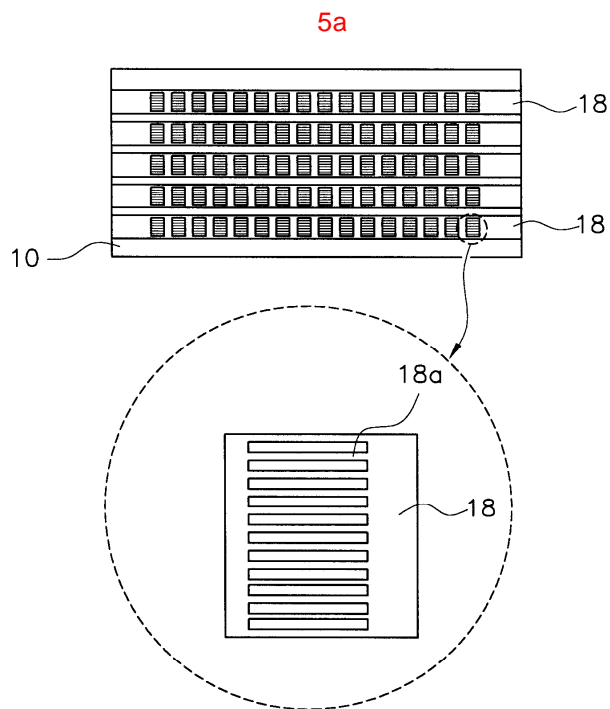
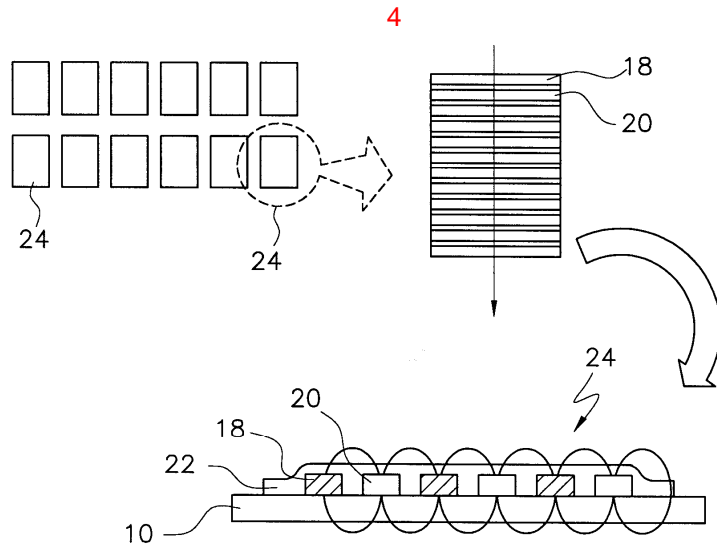

5b

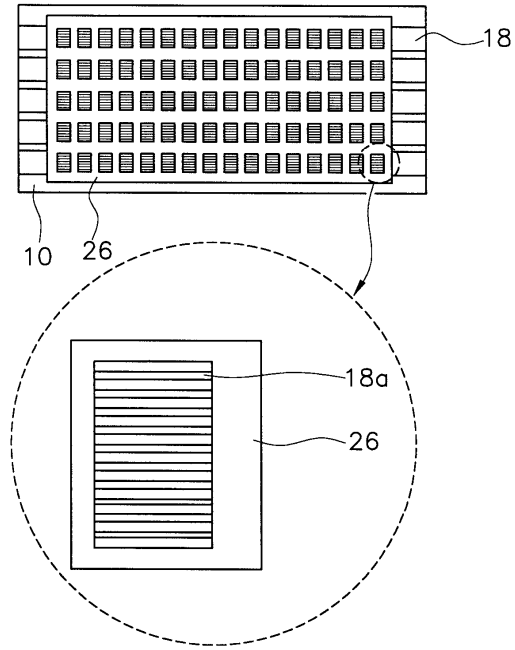

5c

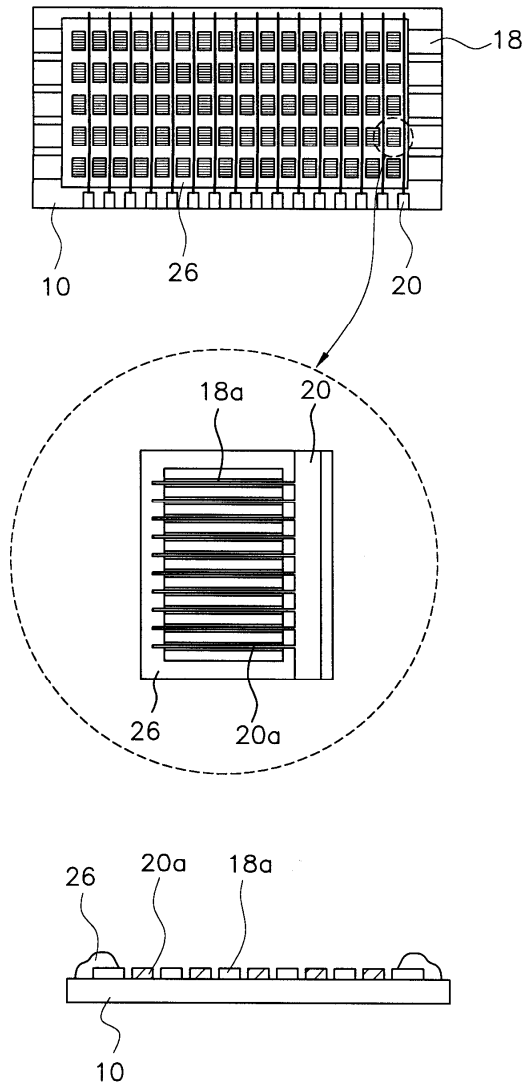

5d

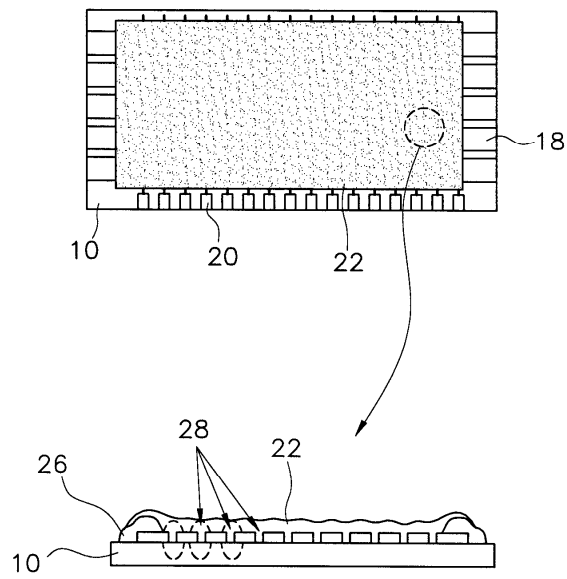

6a

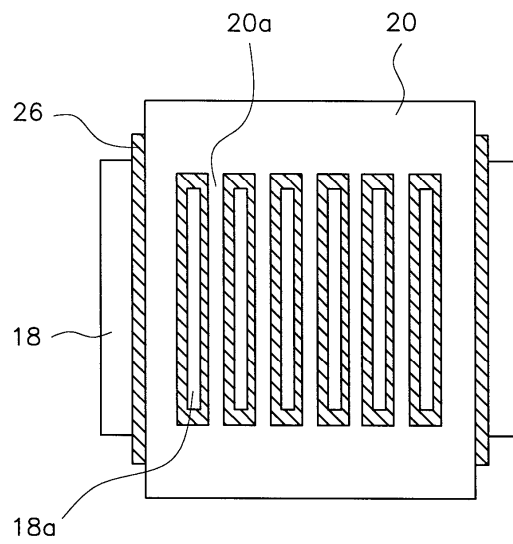

6b

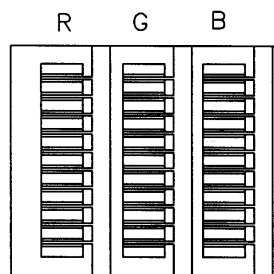

7

