



US 20190009096A1

(19) **United States**

(12) **Patent Application Publication**

Davis et al.

(10) **Pub. No.: US 2019/0009096 A1**

(43) **Pub. Date: Jan. 10, 2019**

(54) **ANTENNA ASSEMBLIES FOR USE WITH
TRANSCUTANEOUSLY POWERED
MEDICAL IMPLANTS**

Publication Classification

(51) **Int. Cl.**
A61N 1/372 (2006.01)
H01Q 1/36 (2006.01)
A61N 1/375 (2006.01)

(52) **U.S. Cl.**
 CPC *A61N 1/37229* (2013.01); *A61N 1/375*
 (2013.01); *H01Q 1/36* (2013.01)

(71) Applicant: **ADVANCED BIONICS AG**, Staefa (CH)

(72) Inventors: **Austin Charles Davis**, Simi Valley, CA (US); **James George Elcoate Smith**, Valencia, CA (US)

(21) Appl. No.: **16/027,220**

(22) Filed: **Jul. 3, 2018**

(57) **ABSTRACT**

Related U.S. Application Data

(60) Provisional application No. 62/530,413, filed on Jul. 10, 2017, provisional application No. 62/530,423, filed on Jul. 10, 2017.

An antenna assembly for use with a medical implant includes an antenna that defines at least one turn and an electromagnetic shield.

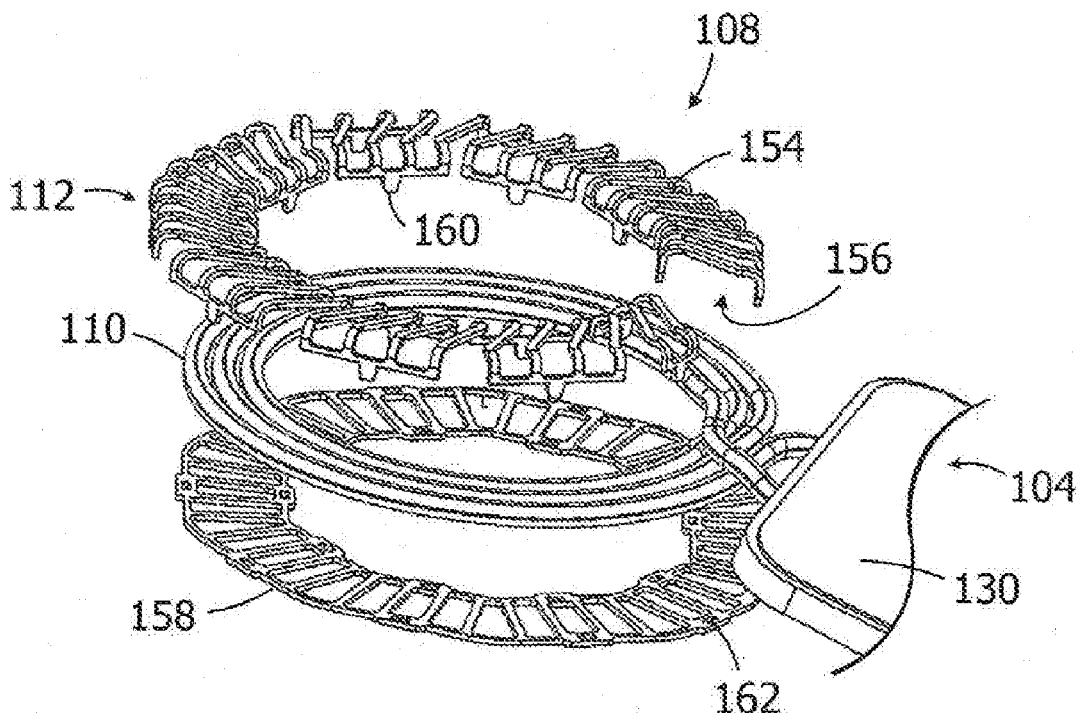

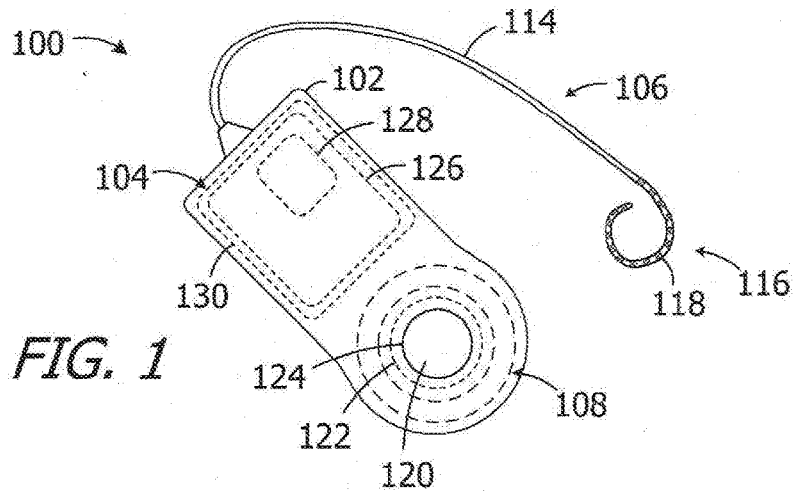

FIG. 1

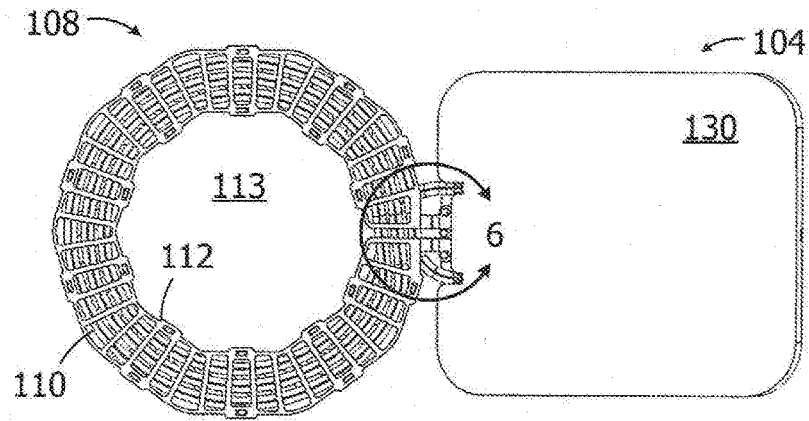

FIG. 2

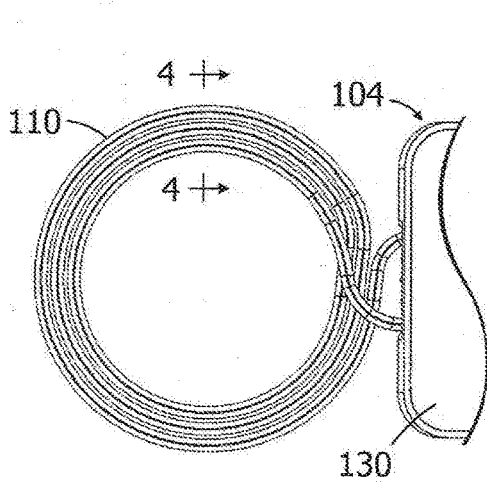

FIG. 3

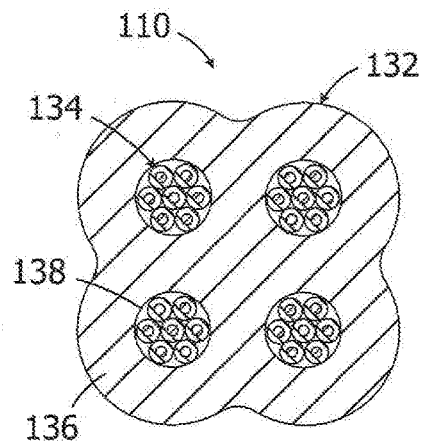

FIG. 4

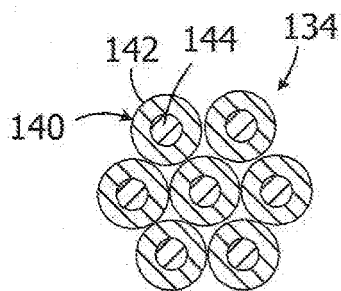

FIG. 5

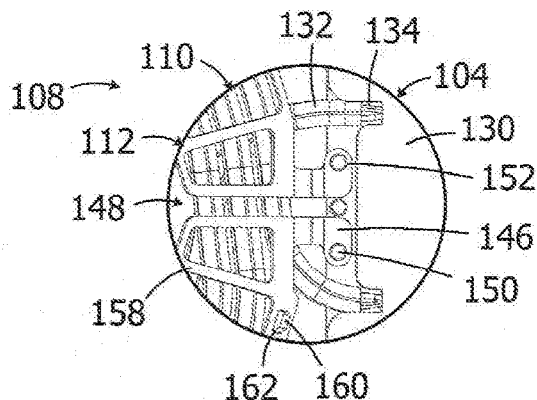

FIG. 6

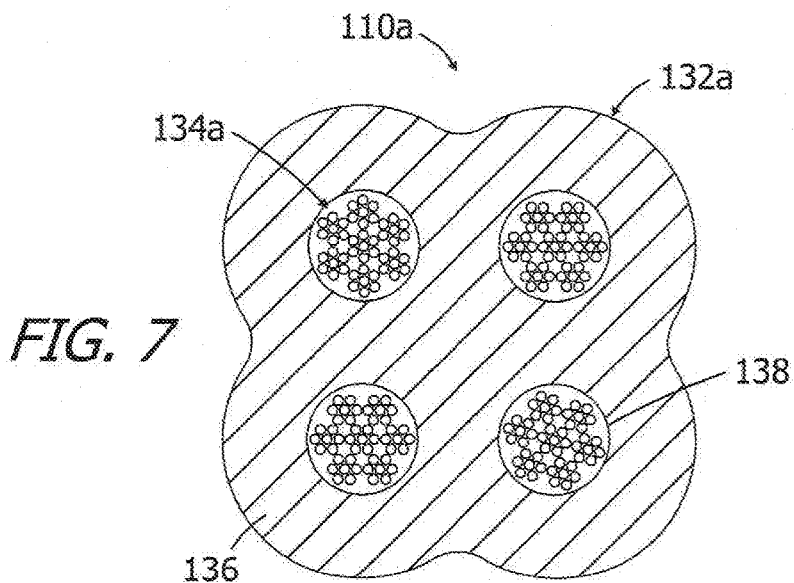

FIG. 7

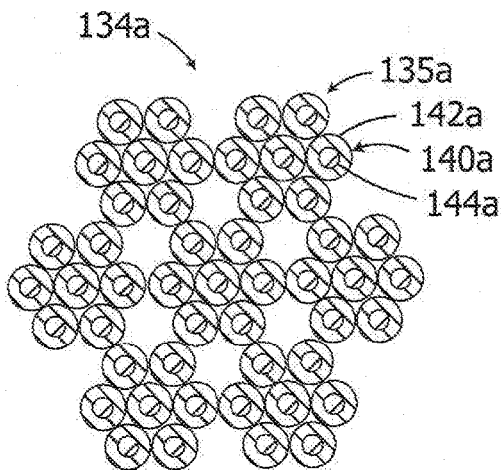

FIG. 8

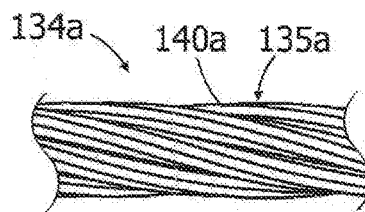
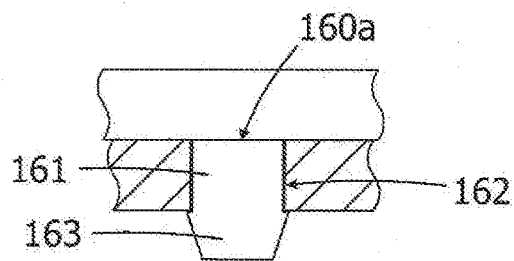
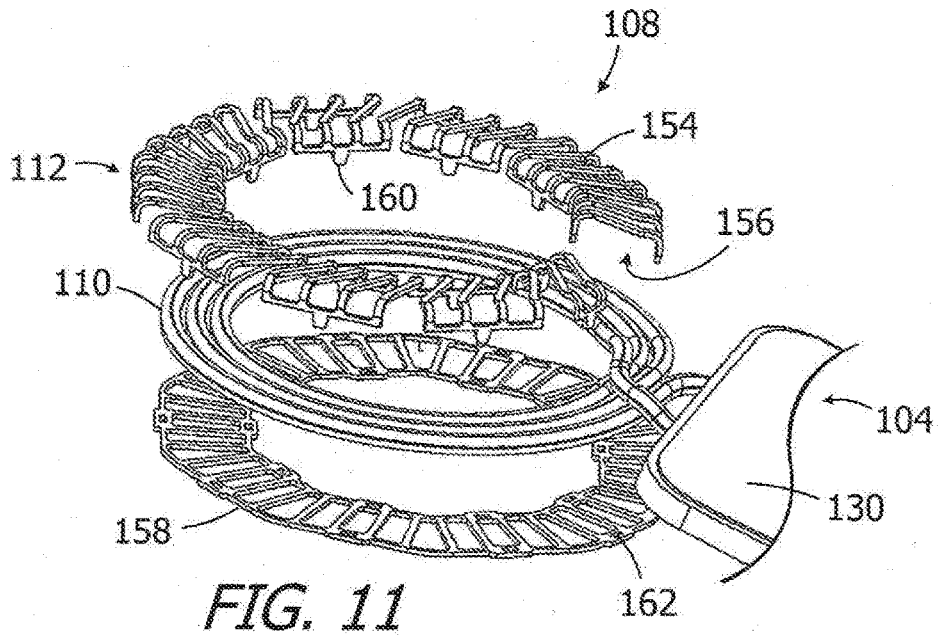
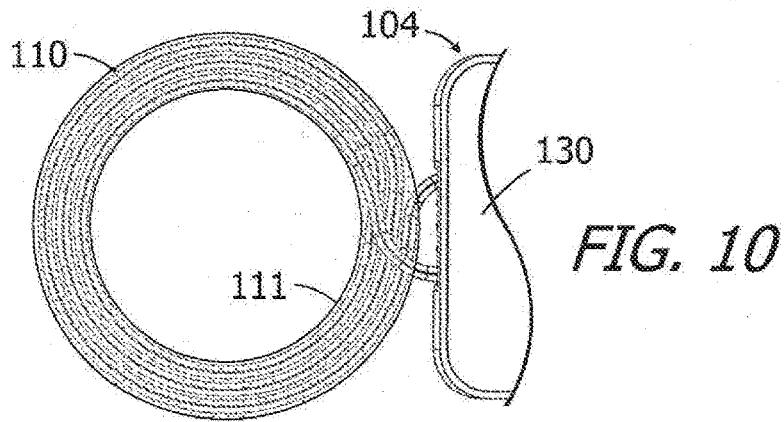
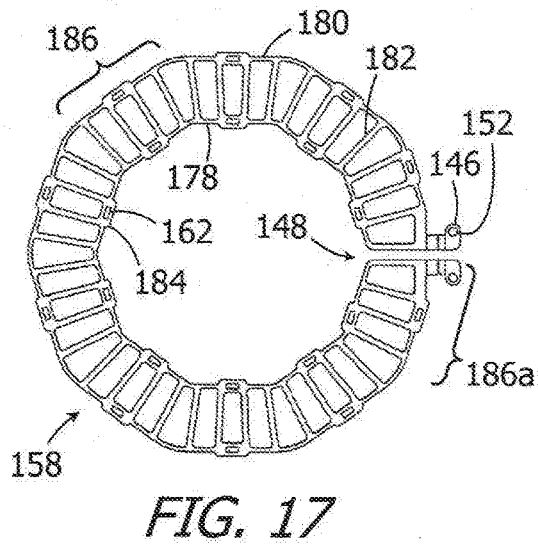
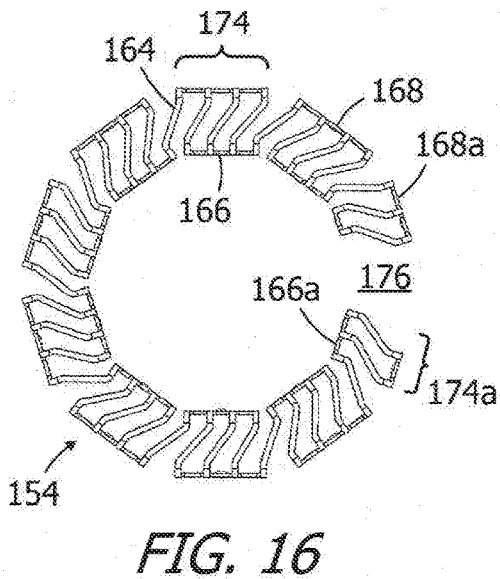
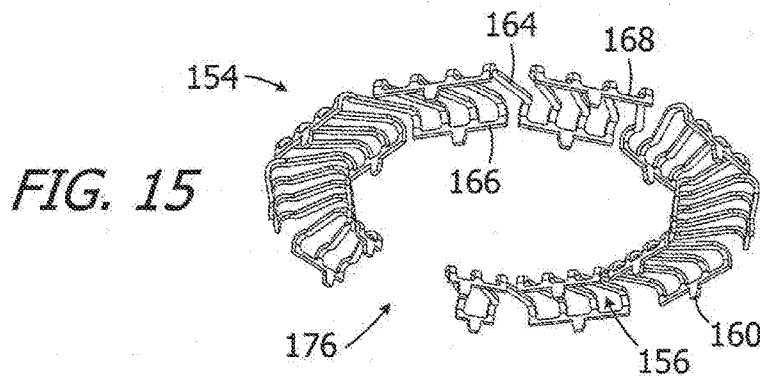
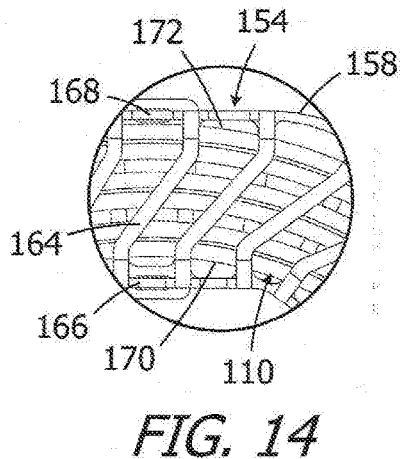
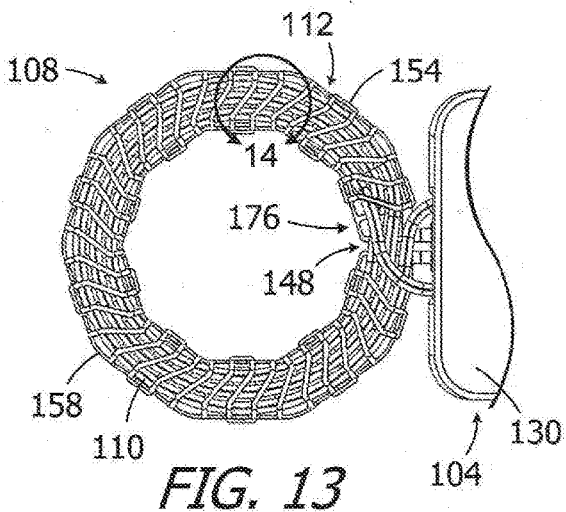

FIG. 9





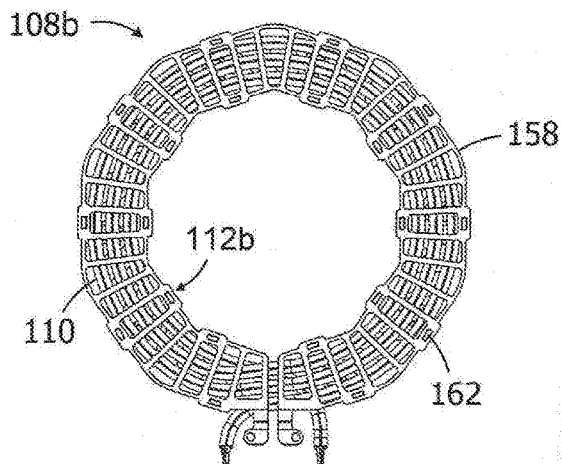

FIG. 18

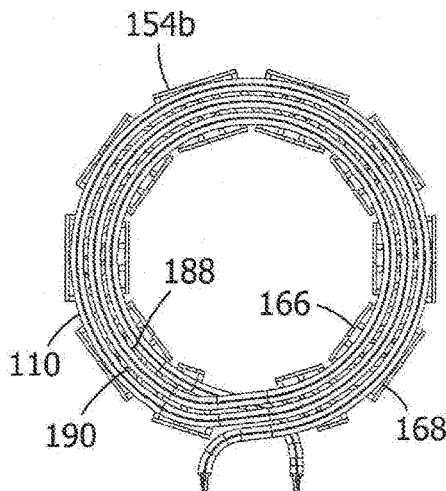

FIG. 19

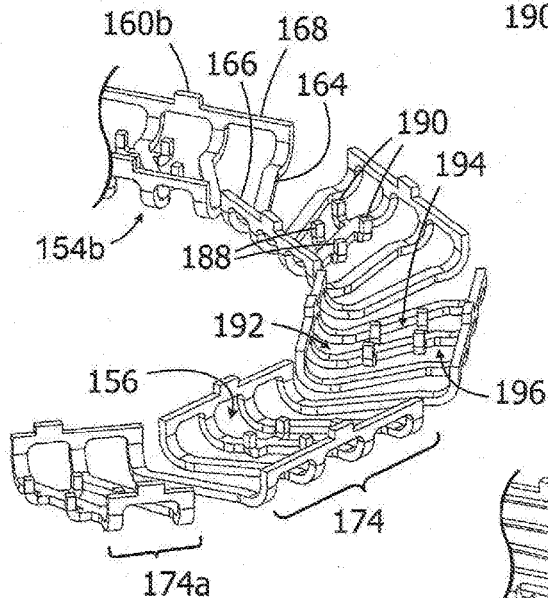

FIG. 20

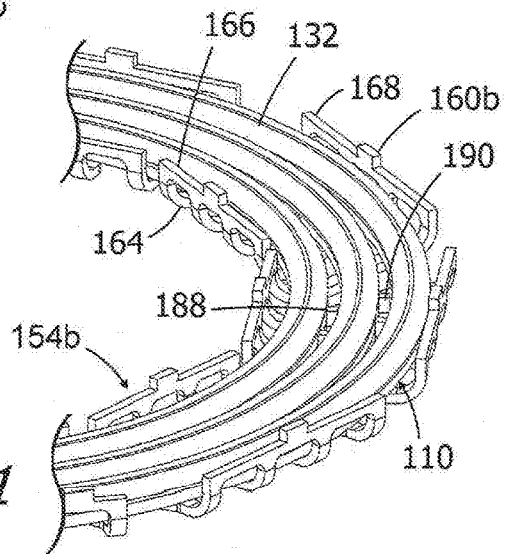

FIG. 21

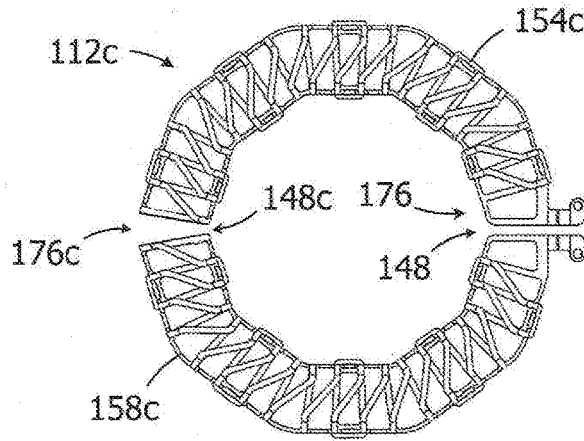

FIG. 22

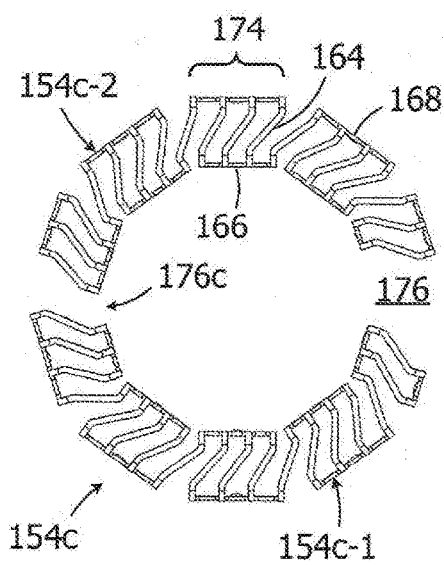

FIG. 23

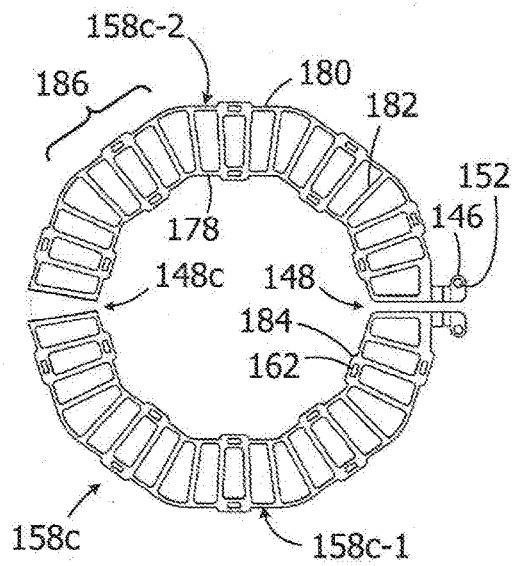
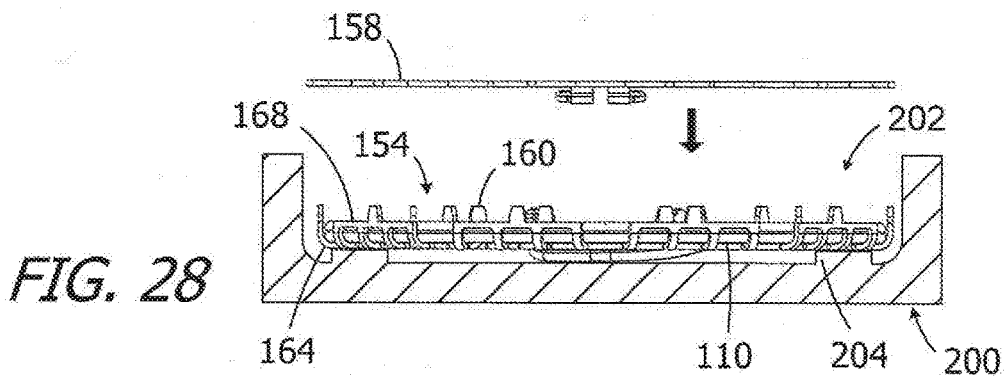
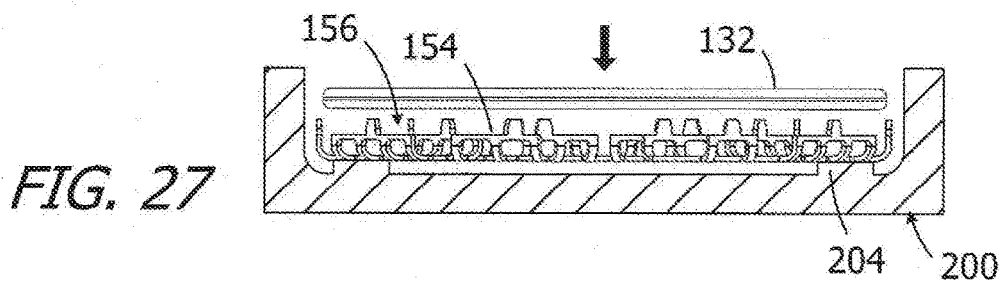
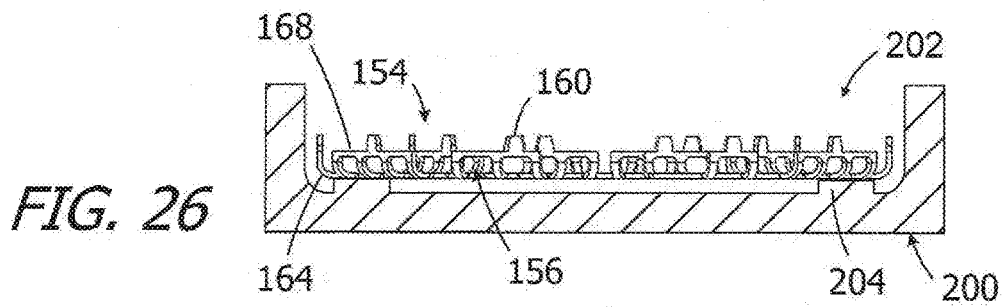
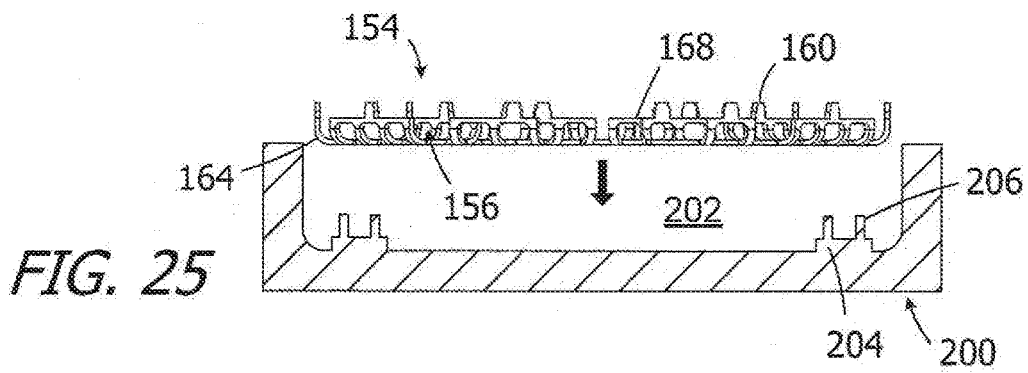

FIG. 24



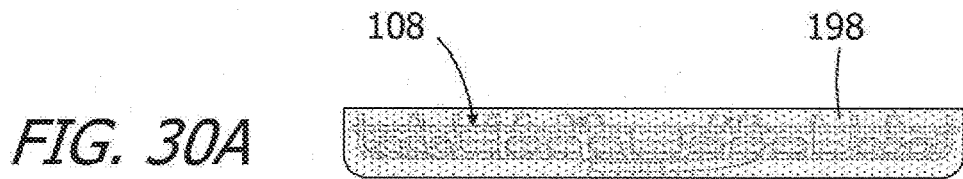
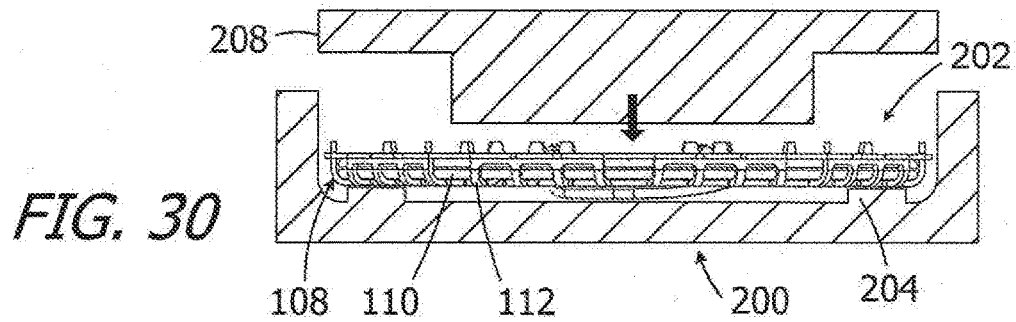
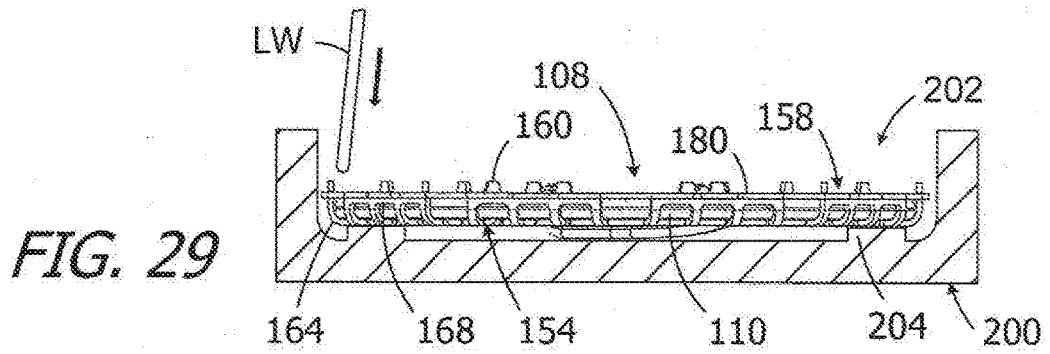

FIG. 31

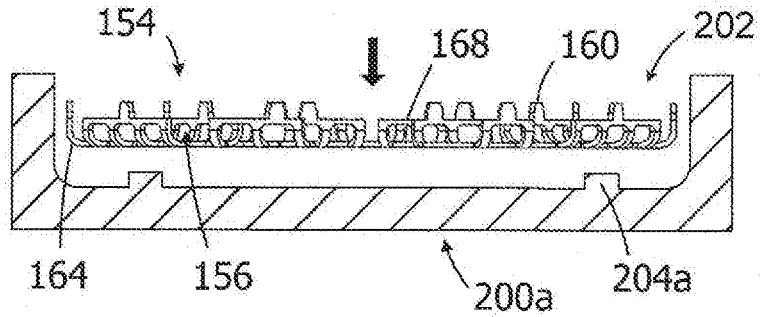

FIG. 32

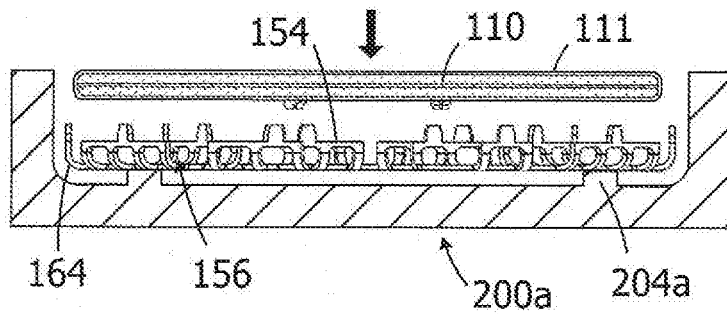

FIG. 33

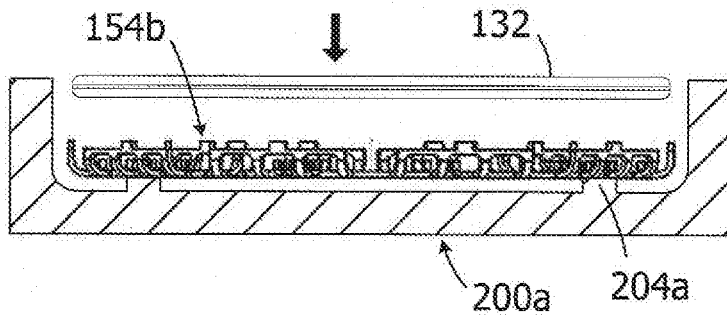
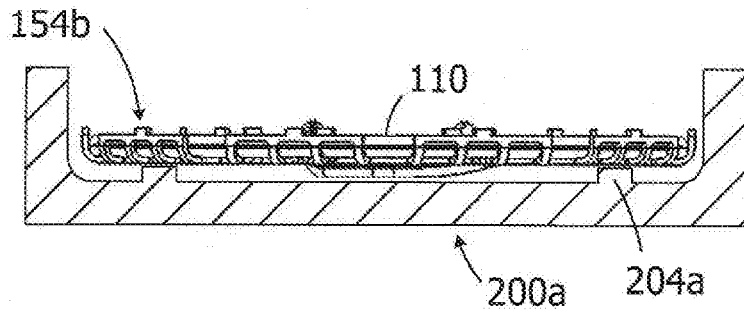
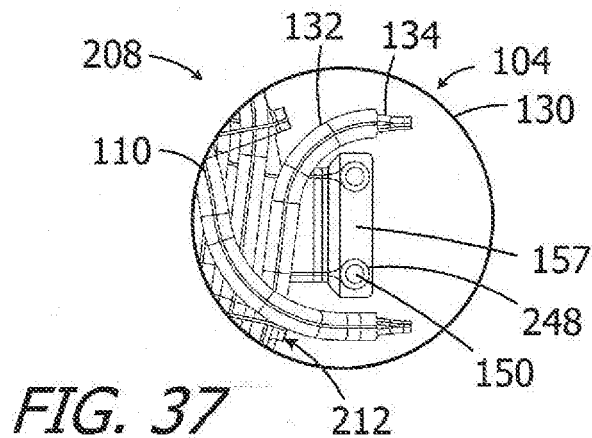
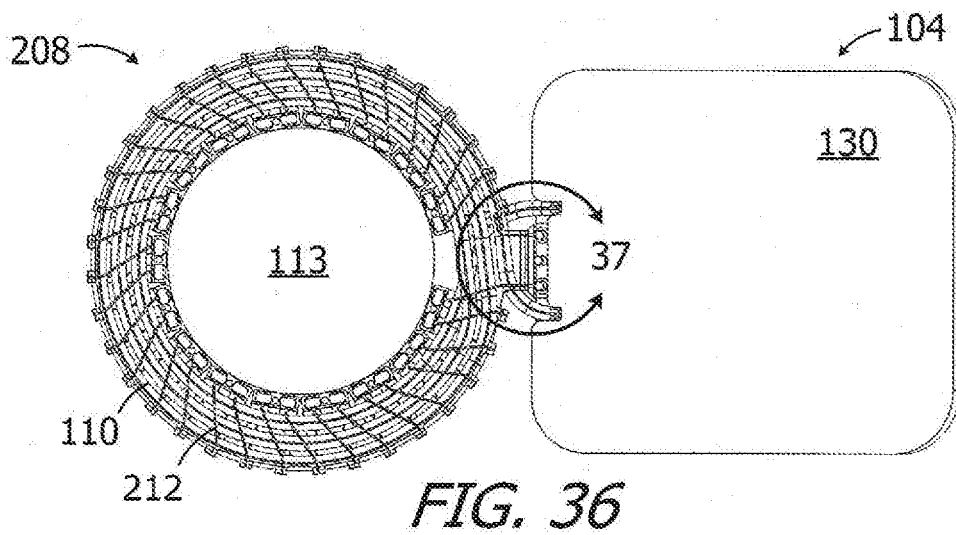
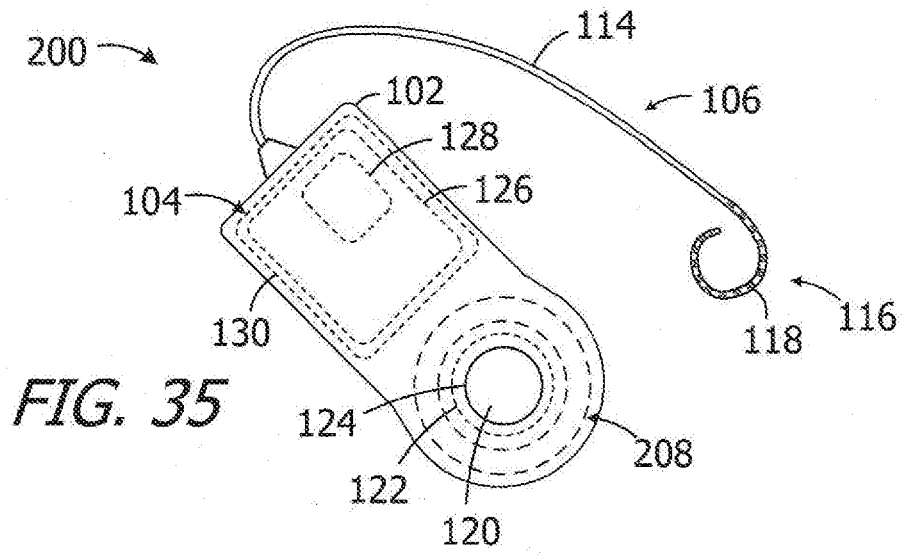
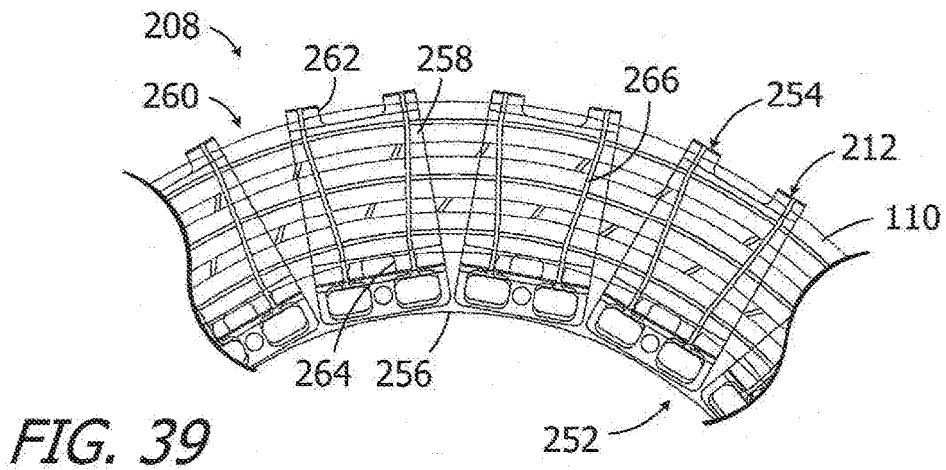
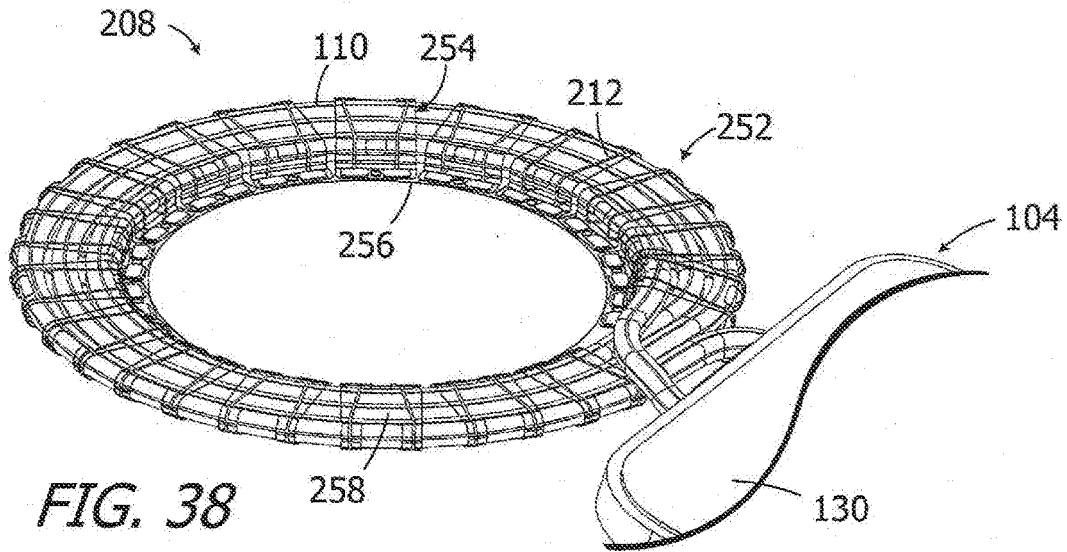

FIG. 34







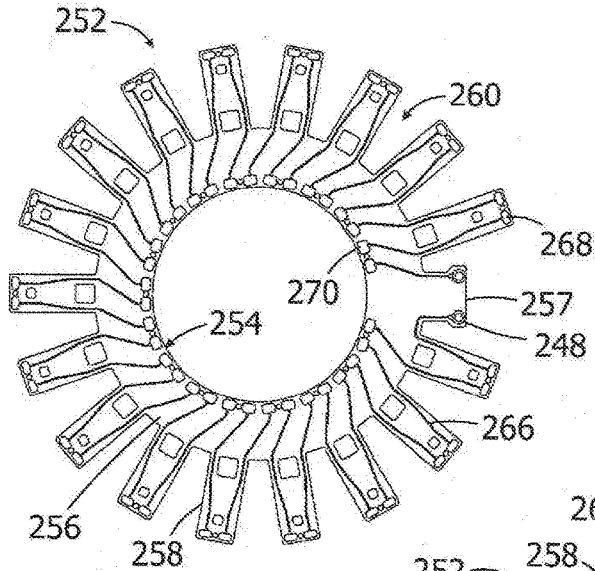

FIG. 40

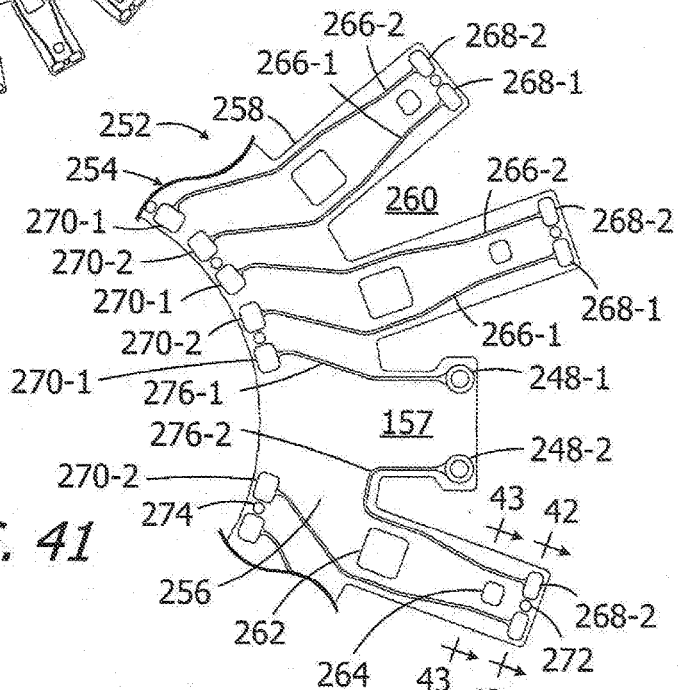

FIG. 41

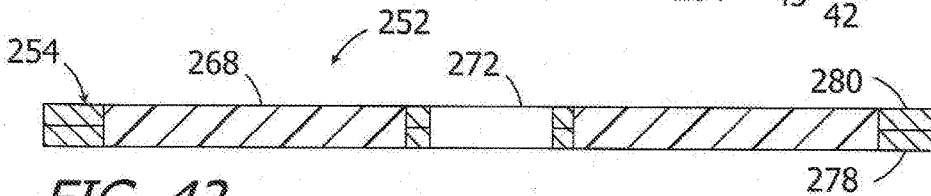

FIG. 42

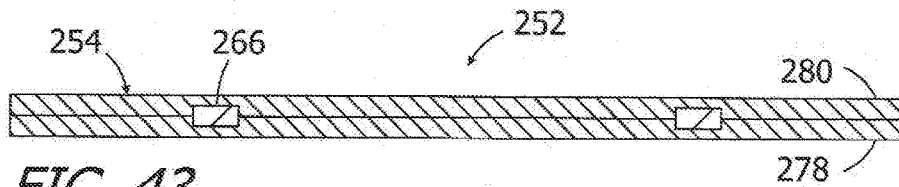
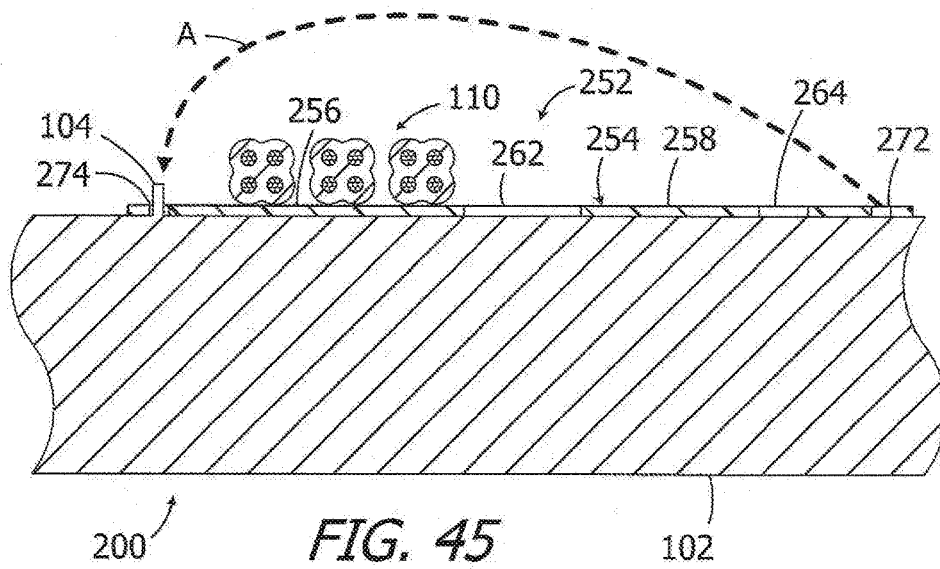
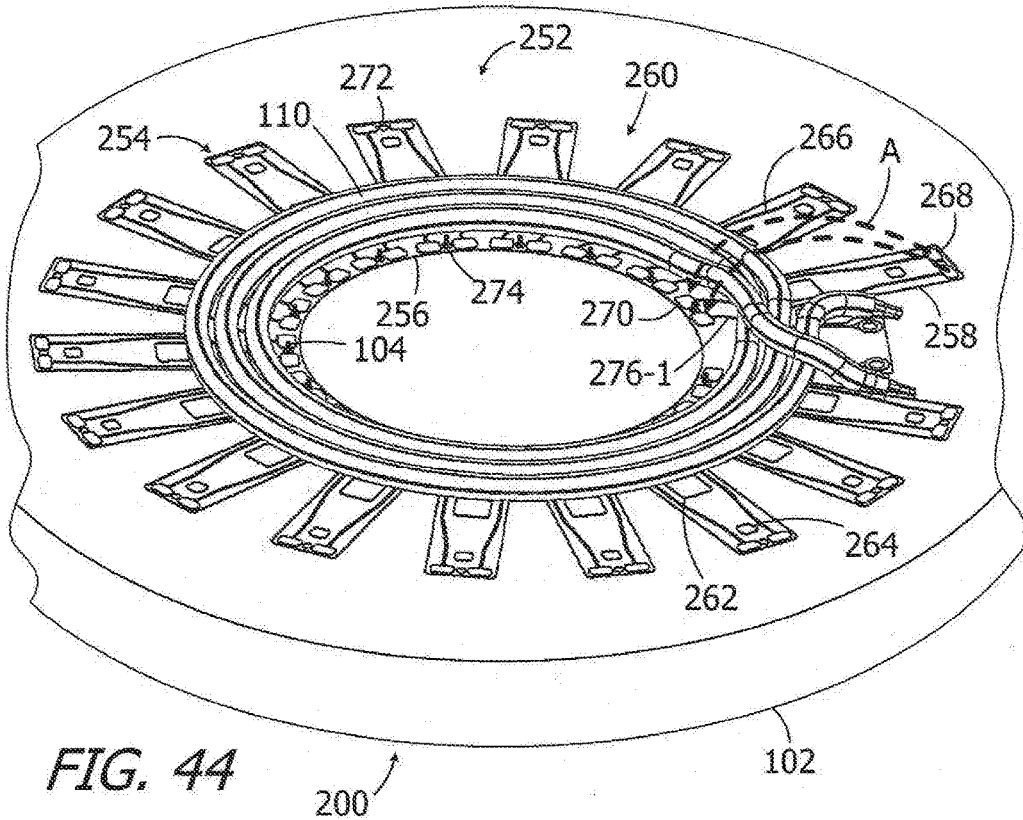
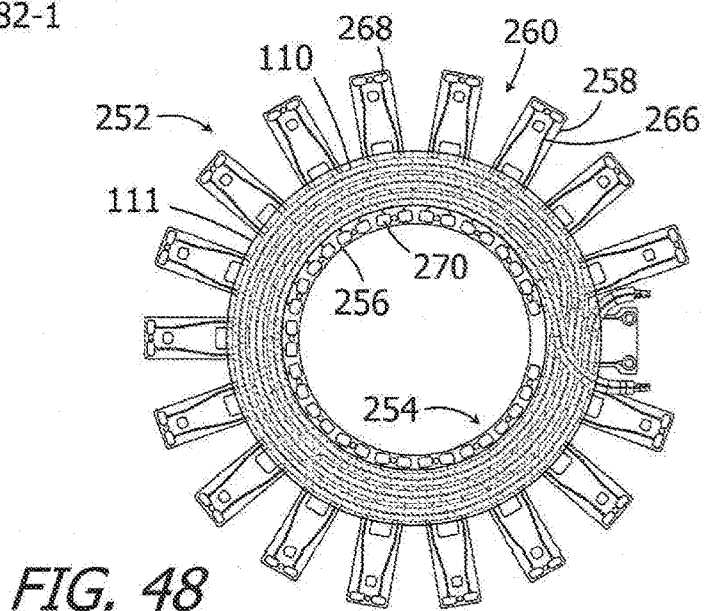
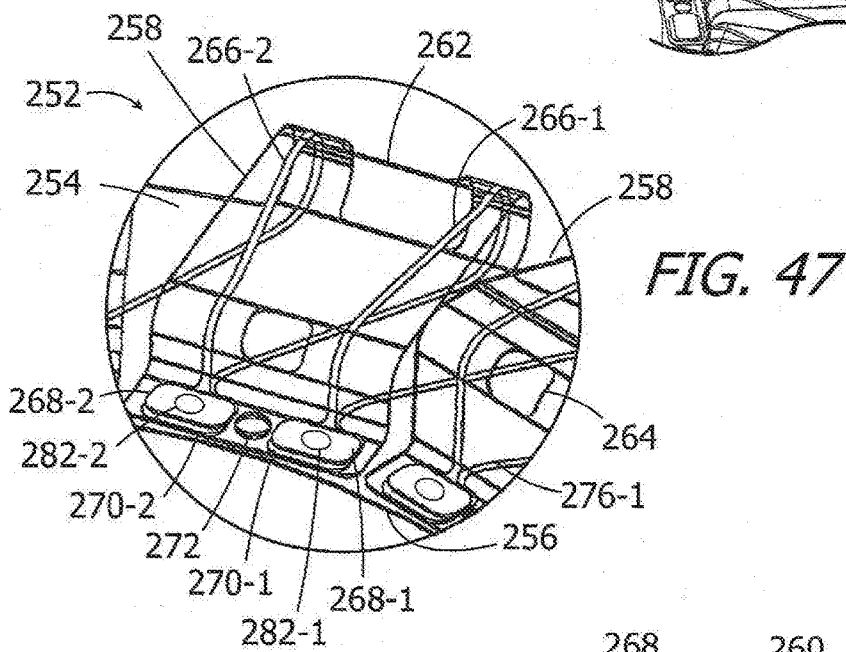
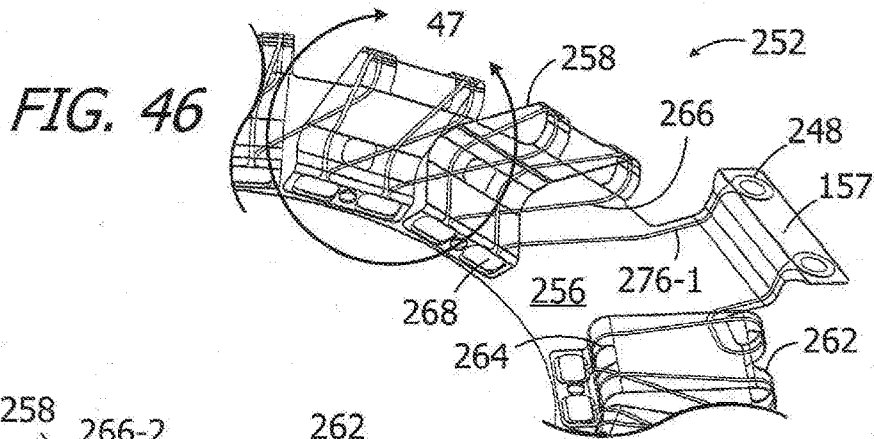

FIG. 43





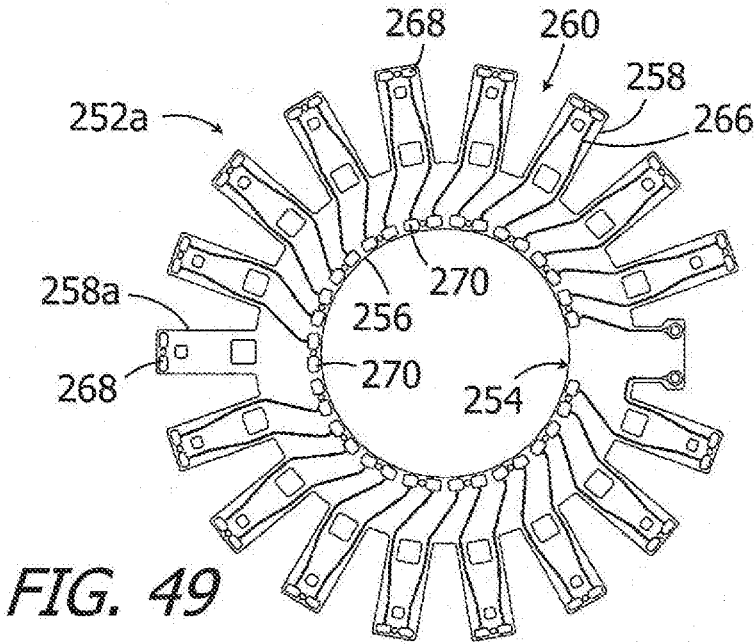

FIG. 49

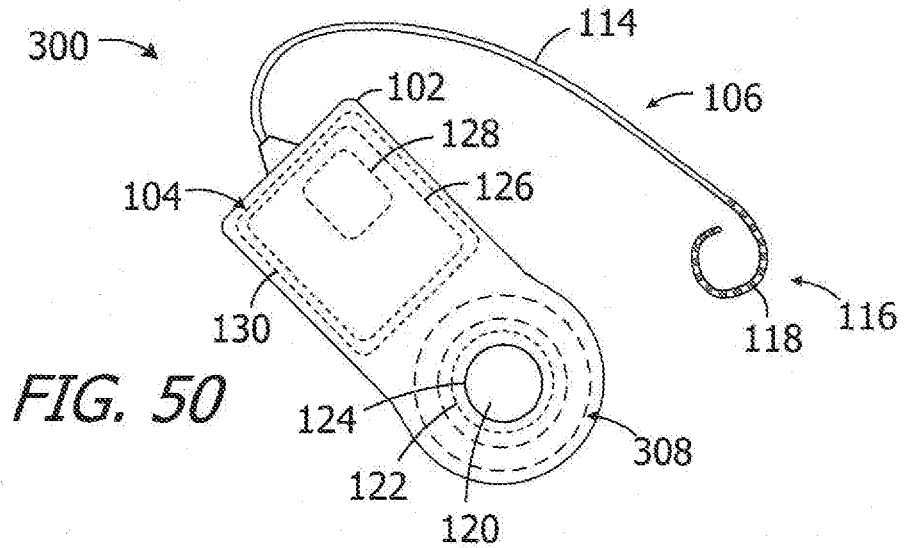

FIG. 50

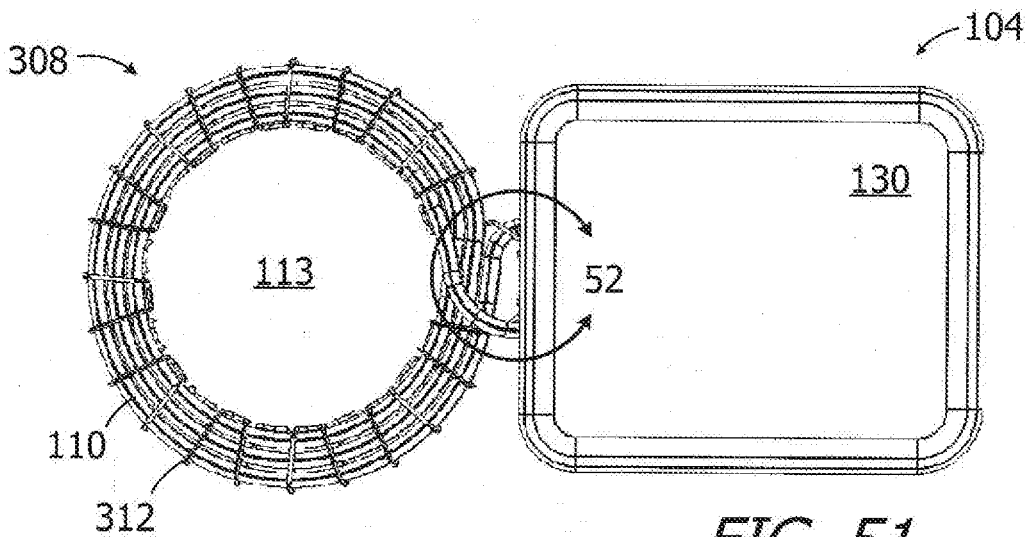

FIG. 51

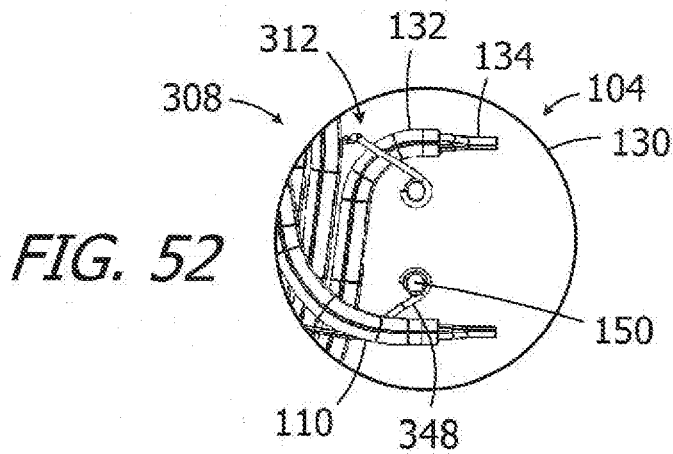

FIG. 52

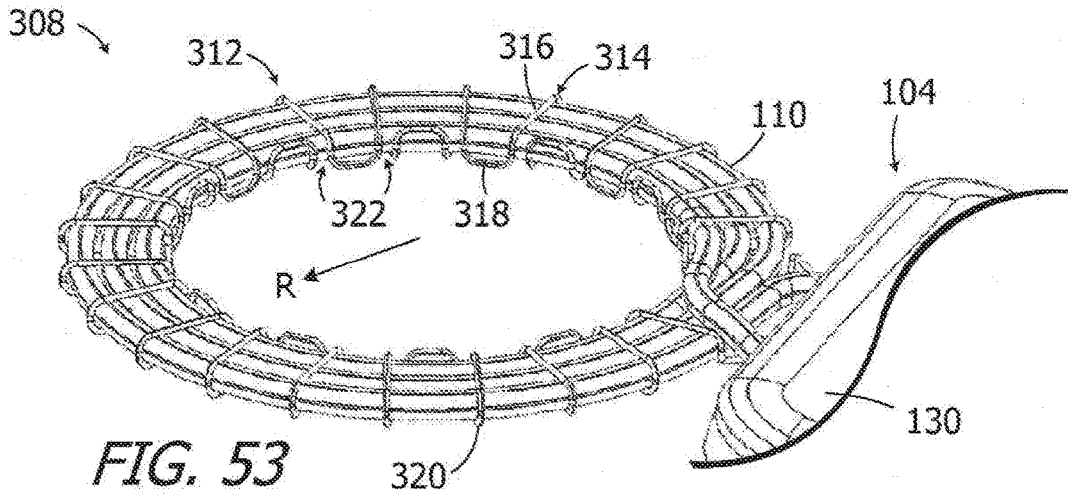

FIG. 53

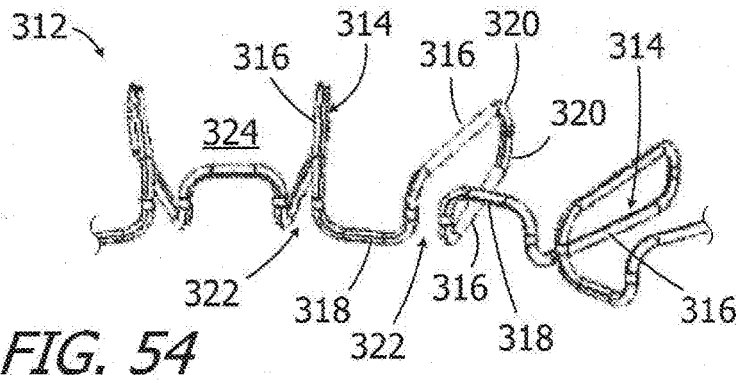

FIG. 54

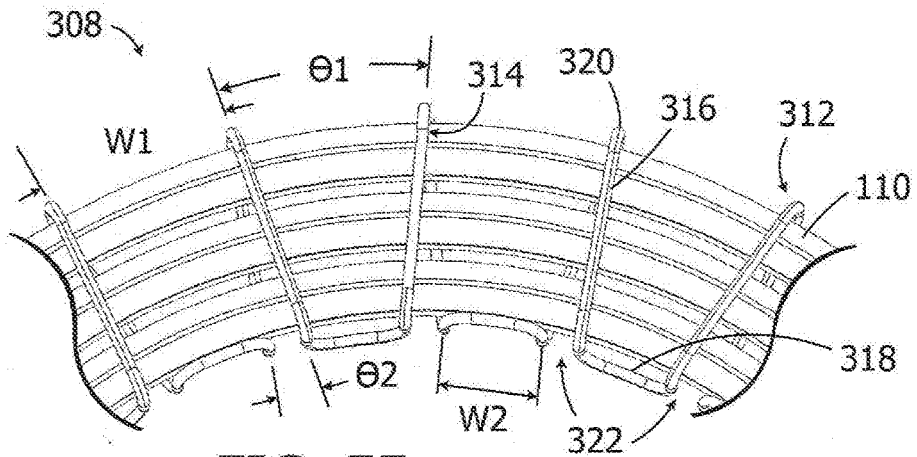

FIG. 55

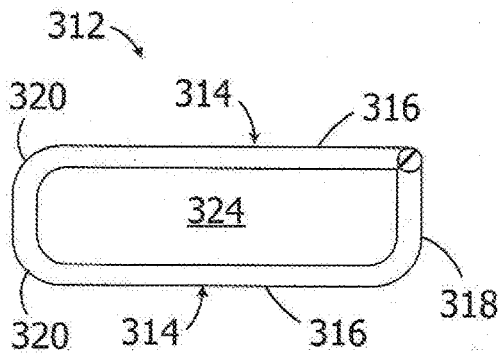

FIG. 56

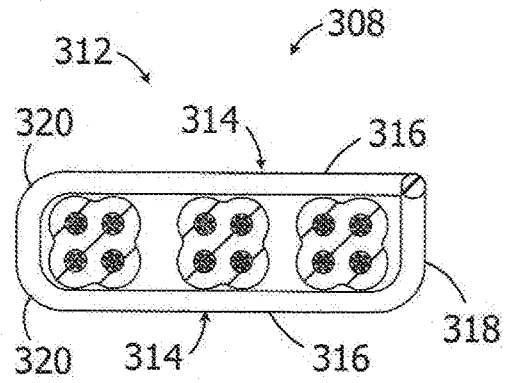

FIG. 59

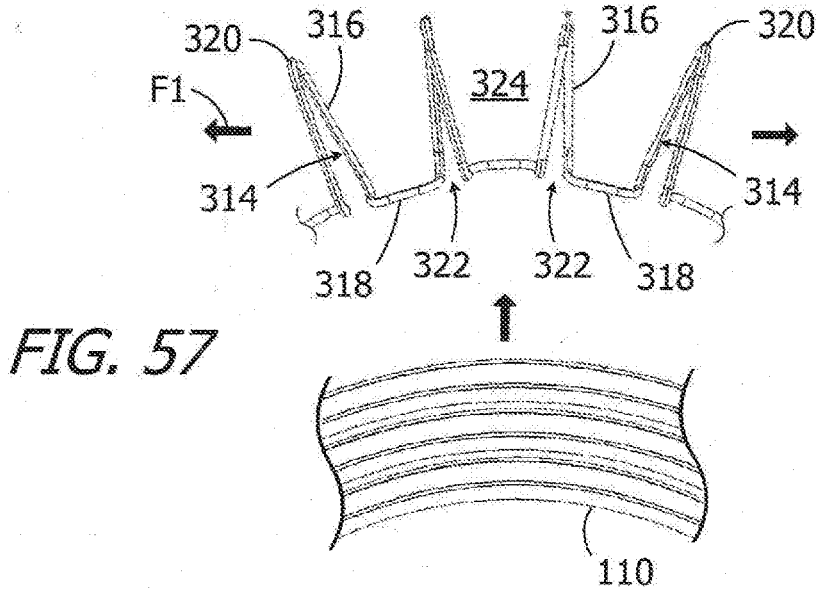

FIG. 57

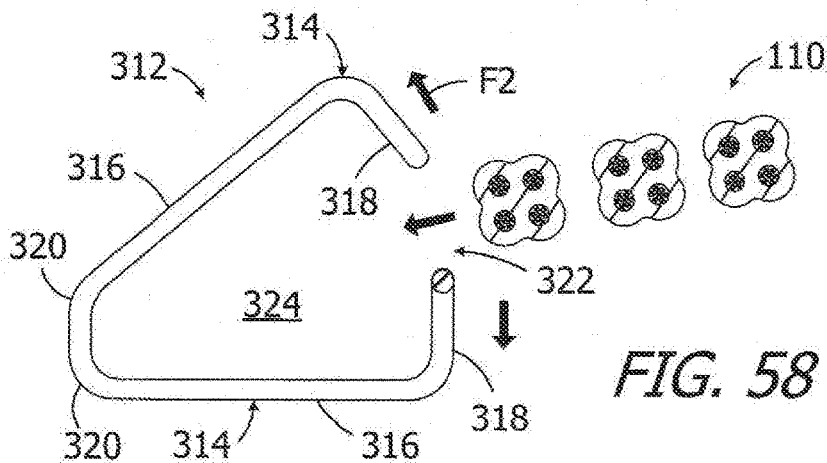

FIG. 58

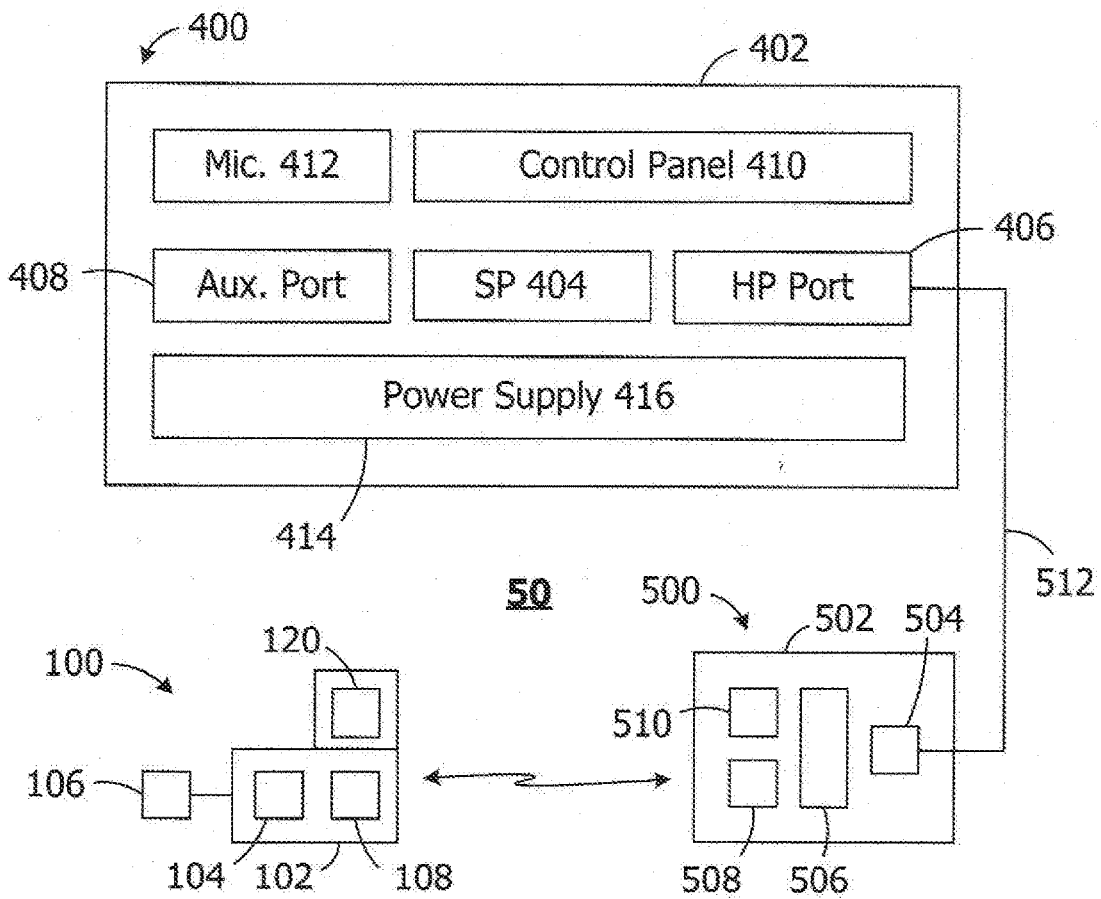

FIG. 60

**ANTENNA ASSEMBLIES FOR USE WITH
TRANSCUTANEOUSLY POWERED
MEDICAL IMPLANTS**

CROSS-REFERENCE TO RELATED
APPLICATIONS

[0001] This application claims the benefit of U.S. Provisional Application No. 62/530,413, filed Jul. 10, 2017, which is incorporated herein by reference. This application also claims the benefit of U.S. Provisional Application No. 62/530,423, filed Jul. 10, 2017, which is incorporated herein by reference.

BACKGROUND

1. Field

[0002] The present disclosure relates generally to transcutaneously powered medical implants.

2. Description of the Related Art

[0003] Inductive links are commonly used to transmit power and data to implanted medical devices such as, for example, prosthetic devices including cochlear implants and retinal implants, cardiac pacemakers, implantable defibrillators, recording devices, and neuromuscular stimulators. The implanted devices include (or are connected to) an internal antenna coil, and an external antenna coil is positioned over the internal antenna coil. Power and in some instances data is supplied to the implanted devices by way of the inductive link between the antenna coils.

[0004] In the exemplary context of implantable cochlear stimulation (“ICS”) systems, which include an external sound processor as well as a cochlear implant with an electrode array within the cochlea, the external antenna coil may be carried by a headpiece that is connected to the external sound processor. The sound processor transmits power and stimulation data (e.g., a pulse sequence having varying pulse widths and/or amplitudes) through a power modulation scheme to the antenna coil of the cochlear implant by way of an inductive link. One conventional implant antenna coil is a three turn inductor that includes a conductor within a non-conductive carrier. The conductor includes biocompatible multi-wire metal cables formed from gold, platinum or titanium wire. Electrical stimulation current is then applied to varying electrode combinations in the electrode array to create a perception of sound. The electrode array may, alternatively, be directly inserted into the cochlear nerve without residing in the cochlea. A representative ICS system is disclosed in U.S. Pat. No. 5,824, 022, which is entitled “Cochlear Stimulation System Employing Behind-The-Ear Sound processor With Remote Control” and incorporated herein by reference in its entirety. Examples of commercially available ICS sound processors include, but are not limited to, the Advanced Bionics Harmony™ BTE sound processor, the Advanced Bionics Naída CI Q Series BTE sound processors and the Advanced Bionics Neptune™ body worn sound processor.

[0005] In some instances, an electromagnetic shield is formed around the antenna coil in order to reduce noise and undesirable alteration of the characteristics of the antenna coil caused by external objects. One exemplary method of forming an electromagnetic shield involves, among other things, overmolding a silicone shield guide onto the antenna

coil, then piercing the molded shield guide at two locations, anchoring a shield wire (such as a platinum wire) at the pierced locations, and carefully wrapping the shield wire around the mold (and antenna coil). The present inventors have determined that the wrapped wire shield is susceptible to improvement. For example, the present inventors have determined that, in addition to being time consuming and expensive, the associated manufacturing process does not produce consistent results. As such, reworking of completed wrapped wire shields is frequently required.

SUMMARY

[0006] An antenna assembly for use with a medical implant includes an antenna that defines at least one turn and an electromagnetic shield with a first shield portion that defines an interior volume with an open end and in which the antenna is located, and a second shield portion, configured to cover the open end of the first shield portion, that is secured to the first shield portion. The present inventions also include implantable medical devices, such as cochlear implants, with such an antenna assembly.

[0007] A method includes the steps of positioning an implantable medical device antenna that defines at least one turn in a first shield portion that defines an interior volume with an open end, and positioning a second shield portion over the open end of the first shield portion.

[0008] An antenna assembly for use with a medical implant includes an antenna that defines at least one turn and an electromagnetic shield assembly wrapped around antenna having an electrically non-conductive flexible shield carrier and an electromagnetic shield carried by the flexible shield carrier. The present inventions also include implantable medical devices, such as cochlear implants, with such an antenna assembly.

[0009] A method includes the step of wrapping an electromagnetic shield assembly, including an electrically non-conductive flexible shield carrier and an electromagnetic shield carried by the flexible shield carrier, around an implantable medical device antenna to form an annularly shaped antenna assembly.

[0010] An antenna assembly for use with a medical implant an antenna that defines at least one turn and an electromagnetic shield that forms a discontinuous loop around the antenna.

[0011] A method includes the steps of deforming at least a portion of an electromagnetic shield with a pre-set overall annular shape in such a manner that a perimeter opening of the electromagnetic shield is enlarged, and inserting a portion of a medical implant antenna defining at least one turn into the deformed portion of the electromagnetic shield by way of the enlarged perimeter opening.

[0012] There are a number of advantages associated with such apparatus and methods. For example, the apparatus and methods simplify and standardize the process of assembling an antenna assembly, thereby reducing the time and expense associated therewith (as compared to conventional methods), and also reduce rework.

[0013] The above described and many other features of the present inventions will become apparent as the inventions become better understood by reference to the following detailed description when considered in conjunction with the accompanying drawings.

BRIEF DESCRIPTION OF THE DRAWINGS

[0014] Detailed descriptions of the exemplary embodiments will be made with reference to the accompanying drawings.

[0015] FIG. 1 is a top view of an exemplary implantable cochlear stimulator in accordance with one embodiment of a present invention.

[0016] FIG. 2 is a bottom view of a portion of the implantable cochlear stimulator illustrated in FIG. 1.

[0017] FIG. 3 is a top view of a portion of the implantable cochlear stimulator illustrated in FIG. 1.

[0018] FIG. 4 is a section view of a single turn taken along line 4-4 in FIG. 3.

[0019] FIG. 5 is a section view of an exemplary conductor.

[0020] FIG. 6 is an enlarged view of a portion of FIG. 2.

[0021] FIG. 7 is a section view of a portion of an exemplary inductor assembly.

[0022] FIG. 8 is a section view of an exemplary inductor.

[0023] FIG. 9 is a side view of an exemplary inductor.

[0024] FIG. 10 is a top view of a portion of an implantable cochlear stimulator.

[0025] FIG. 11 is a partially exploded perspective view of a portion of the implantable cochlear stimulator illustrated in FIG. 1.

[0026] FIG. 12 is a side, partial section view of an exemplary shield latch.

[0027] FIG. 13 is a top view of a portion of the implantable cochlear stimulator illustrated in FIG. 1.

[0028] FIG. 14 is an enlarged view of a portion of FIG. 13.

[0029] FIG. 15 is a perspective view of a portion of the implantable cochlear stimulator illustrated in FIG. 1.

[0030] FIG. 16 is a top view of a portion of the implantable cochlear stimulator illustrated in FIG. 1.

[0031] FIG. 17 is a top view of a portion of the implantable cochlear stimulator illustrated in FIG. 1.

[0032] FIG. 18 is a bottom view of an antenna assembly in accordance with one embodiment of a present invention.

[0033] FIG. 19 is a bottom view of a portion antenna assembly illustrated in FIG. 18.

[0034] FIG. 20 is a perspective view of a portion antenna assembly illustrated in FIG. 18.

[0035] FIG. 21 is a perspective view of a portion antenna assembly illustrated in FIG. 18.

[0036] FIG. 22 is a top view of an electromagnetic shield in accordance with one embodiment of a present invention.

[0037] FIG. 23 is a top view of a portion of the electromagnetic shield illustrated in FIG. 18.

[0038] FIG. 24 is a top view of a portion of the electromagnetic shield illustrated in FIG. 22.

[0039] FIGS. 25-30 are partial section views showing respective portions of a method in accordance with one embodiment of a present invention.

[0040] FIG. 30A is an end view of an antenna assembly in accordance with one embodiment of a present invention.

[0041] FIGS. 31 and 32 are partial section views showing respective portions of a method in accordance with one embodiment of a present invention.

[0042] FIGS. 33 and 34 are partial section views showing respective portions of a method in accordance with one embodiment of a present invention.

[0043] FIG. 35 is a top view of an exemplary implantable cochlear stimulator in accordance with one embodiment of a present invention.

[0044] FIG. 36 is a bottom view of a portion of the implantable cochlear stimulator illustrated in FIG. 35.

[0045] FIG. 37 is an enlarged view of a portion of FIG. 36.

[0046] FIG. 38 is a perspective view of a portion of the implantable cochlear stimulator illustrated in FIG. 35.

[0047] FIG. 39 is a top view of a portion of the implantable cochlear stimulator illustrated in FIG. 35.

[0048] FIG. 40 is a top view of a shield assembly in accordance with one embodiment of a present invention prior to being wrapped around an antenna.

[0049] FIG. 41 is an enlarged view of a portion of FIG. 40.

[0050] FIG. 42 is a section view taken along line 42-42 in FIG. 41.

[0051] FIG. 43 is a section view taken along line 43-43 in FIG. 41.

[0052] FIG. 44 is a perspective view of a portion of a method in accordance with one embodiment of a present invention.

[0053] FIG. 45 is a section view of a portion of a method in accordance with one embodiment of a present invention.

[0054] FIG. 46 is a perspective view of a portion of the shield assembly illustrated in FIG. 38.

[0055] FIG. 47 is an enlarged view of a portion of FIG. 46.

[0056] FIG. 48 is a top view of an antenna assembly in accordance with one embodiment of a present invention in an unassembled state.

[0057] FIG. 49 is a top view of a shield assembly in accordance with one embodiment of a present invention prior to being wrapped around an antenna.

[0058] FIG. 50 is a top view of an exemplary implantable cochlear stimulator in accordance with one embodiment of a present invention.

[0059] FIG. 51 is a bottom view of a portion of the implantable cochlear stimulator illustrated in FIG. 50.

[0060] FIG. 52 is an enlarged view of a portion of FIG. 51.

[0061] FIG. 53 is a perspective view of a portion of the implantable cochlear stimulator illustrated in FIG. 50.

[0062] FIG. 54 is a perspective view of a portion of the implantable cochlear stimulator illustrated in FIG. 50.

[0063] FIG. 55 is a top view of a portion of the implantable cochlear stimulator illustrated in FIG. 50.

[0064] FIGS. 56-59 are section views showing respective portions of methods in accordance with embodiment of present inventions.

[0065] FIG. 60 is a diagrammatic view of an exemplary ICS system.

DETAILED DESCRIPTION OF THE EXEMPLARY EMBODIMENTS

[0066] The following is a detailed description of the best presently known modes of carrying out the inventions. This description is not to be taken in a limiting sense, but is made merely for the purpose of illustrating the general principles of the inventions.

[0067] The present inventions have application in a wide variety of systems including, but not limited to, those that provide sound (i.e., either sound or a perception of sound) to the hearing impaired. One example of such a system is an ICS system where an external sound processor communicates with a cochlear implant and, accordingly, the present inventions may be discussed in the context of cochlear implants. The present inventions are not, however, so limited, and have application in other systems where, for

example, power and data are transmitted to an implanted medical device by way of an inductive link.

[0068] One example of a cochlear implant (or “implantable cochlear stimulator”) is the cochlear implant **100** illustrated in FIGS. **1** and **2**. The cochlear implant **100** includes a flexible housing **102** formed from a silicone elastomer or other suitable material, a processor assembly **104**, a cochlear lead **106**, and an antenna assembly **108** with an antenna coil (or “antenna”) **110** and an electromagnetic shield (or “shield”) **112**. The antenna **110** may be used to receive data and power by way of an external antenna that is associated with, for example, a sound processor unit, while the electromagnetic shield **112** functions in a manner similar to the electromagnetic shields in other hearing related devices. The cochlear lead **106** may include a flexible body **114**, an electrode array **116** at one end of the flexible body, and a plurality of wires (not shown) that extend through the flexible body from the electrodes **118** (e.g., platinum electrodes) in the array **116** to the other end of the flexible body. A magnet **120** is located within a region encircled by the antenna assembly **108** (e.g., within an internal pocket **122** defined by the housing **102**). The magnet **120** ensures that an external antenna will be properly positioned relative to the antenna **110**. The antenna assembly **108**, as well as the other antenna assemblies described below, have an overall annular shape with an open central region **113** to accommodate the magnet **120** and magnet pocket **122**. An opening **124** allows the magnet **120** to be removed from the internal pocket **122** if necessary. The exemplary processor assembly **104**, which is connected to the electrode array **116** and antenna **110**, includes a printed circuit board **126** with a stimulation processor **128** that is located within a hermetically sealed case **130**. The case **130** may be formed from titanium or other suitable materials. The stimulation processor **128** converts the stimulation data into stimulation signals that are transmitted to the cochlea by way of the electrodes **118** of the electrode array **116**.

[0069] Referring to FIGS. **3-5**, the exemplary antenna **110** is formed by an inductor assembly **132** that includes one or more metallic conductors **134**. The metallic conductors are located within a carrier **136** that maintains the position of the metallic conductors relative to one another. The inductor assembly **132** defines one or more turns (or “loops” or “windings”), the number of which is determined by the intended application, and there are three turns in the illustrated embodiment. The exemplary carrier **136** includes a lumen **138** for each one of the metallic conductors **134**. The carrier **136** may be formed from a dense elastomeric electrically non-conductive material such as silicone rubber. Turning to FIG. **5**, the conductors **134** may be in the form of multi-wire cables (sometimes referred to as “Litz wires”), and each wire **140** may be a drawn filled tubing (“DFT”) that includes an outer tube **142** (e.g., an MP35N® nickel alloy tube) filled with an inner core **144** (e.g., a silver or silver alloy core). DFT is a registered trademark of Fort Wayne Metals Research Products Corp. and MP35N is a registered trademark of SPS Technologies. In the illustrated embodiment, the conductors **134** include seven wires **140** that are arranged in a hexagonal formation where six of the wires are twisted around a center wire. The ends of the metallic conductors **134** are exposed (FIG. **6**) so as to facilitate connection to the circuitry within the processor assembly **104**.

[0070] The exemplary antennas **110** and **110a** (below) are also sized for use in a cochlear implant. As such, the outer diameter of the antennas **110** and **110a** may be from 15 mm to 30 mm. In other implantable medical device applications, the antenna diameter may be from 5 mm to 15 mm.

[0071] As illustrated in FIG. **6**, the exemplary shield **112** includes a pair of connector tabs **146** that are located on opposite sides of a gap **148**. The shield tabs **146** are connected to the titanium case **130**, and the case is connected to ground circuitry within the case. In the illustrated implementation, the case **130** includes a pair of alignment posts **150** that orient shield **112** relative to the case, the tabs **146** include alignment apertures **152** through which the posts extend, and the tabs are welded to the case.

[0072] Another exemplary antenna, which may be employed in place of the antenna **110**, is generally represented by reference numeral **110a** in FIG. **7** and similar elements are represented by similar reference numerals. The antenna **110a** includes an inductor assembly **132a** with a plurality of conductors **134a** (FIGS. **8** and **9**). Each conductor **134a** may be formed from a plurality of multi-wire cables **135a**. Each wire **140a** in the cables **135a** may be in the form of DFT with an outer tube **142a** and an inner core **144a**. In the illustrated embodiment, the conductors **134a** include seven multi-wire cables **135a** that are arranged in a hexagonal formation where six of the cables **135a** are twisted around a center cable, and each cable **135a** include seven wires **140a** arranged in a hexagonal formation where six of the wires are twisted around a center wire. Additional information concerning the antenna **110a** may be found in WO Pub. No. 2016/171833, which is incorporated herein by reference in its entirety.

[0073] There may be some instances where an antenna **110** (or **110a**) will not self-maintain the three concentric loops shape illustrated in FIG. **3** or other desired shape. One exemplary method of maintaining the antenna in the desired shape involves overmolding an antenna holder **111** (FIG. **10**), which may be formed from silicone or other suitable materials, onto the antenna **110** (or **110a**). The antenna holder **111** will be positioned within the shield **112** along with the antenna **110** during the assembly process. Other instrumentalities and methods for maintaining antenna shape are described below with reference to FIGS. **18-21** and **25-30A**.

[0074] Turning to FIG. **11**, the exemplary shield **112** is a two-piece cage-like structure that extends around the antenna **110**. The shield **112** includes a first shield portion **154** that defines an interior volume **156** for the antenna **110** and a second shield portion **158** that covers the open end of the interior volume. The first and second shield portions **154** and **158** are separate structures that are secured to one another during the assembly process. At least one of the first and second shield portions **154** and **158** includes alignment apparatus that is configured to align the first and second shield portions with one another as the first and second shield portions are brought into contact with one another during assembly of the shield. In the illustrated embodiment, the first and second shield portions **154** and **158** also respectively include one or more alignment tabs **160** and one or more apertures **162** that orient the first and second shield portions relative to one another. The first and second shield portions **154** and **158** may be welded (or crimped, soldered, or brazed) to one another at the tab **160**/aperture **162** locations during the assembly process, or at other locations

around the inner and/or outer perimeters of the shield **112**, as is described below with reference to FIG. **29**. Biocompatible conductive epoxy may also be used to secure the shield portions **154** and **158** to one another. In other implementations, apertures may be located on the first shield portion **154** and tabs may be located on the second shield portion. It should also be noted here that the tabs **160** may be slightly smaller than the apertures **162** (as shown), or slightly larger to ensure a tight fit.

[0075] In other instances, the tabs and apertures may be configured such that, in addition to being properly aligned, the first and second shield portions **154** and **158** will be mechanically connected to one another when they are brought together. Any suitable instrumentality that secures the shield portions to one another may be employed. By way of example, and referring to FIG. **12**, the exemplary tab **160a** (which may be employed in place of tabs **160**) includes a relatively narrow portion **161** and a tapered latch **163** that mechanically interconnects with the second shield portion **158** after passing through the aperture **160**.

[0076] In those instances where an overmolded antenna holder **111** is employed, the outer surface of the antenna holder may include protrusions and indentations (not shown) that will align the first and second shield portions **154** and **158** with one another.

[0077] Referring to FIGS. **13-17**, the first portion **154** of the exemplary shield **112** includes a plurality of spaced apart arch-shaped members **164** that are connected to inner and outer base members **166** and **168**. The arch-shaped members **164** extend across the associated portions of the antenna **110**, from the inner edge **170** to the outer edge **172**, while the base members **166** extend in a direction that is tangential to the associated portion of the antenna. In the illustrated implementation, the arch-shaped members **164** and base members **166/168** are arranged in groups **174** that include five arch-shaped members, although some of the arch-shaped members are shared. One arch-shaped member **164** in each group is connected to the base member **166** of one adjacent group, while another arch-shaped member **164** in each group **174** is connected to the base member **168** of the other adjacent group. The end groups **174a**, which may include fewer arch-shaped members **164** and shorter inner and outer base members **166a** and **168a**, are each connected to a single group **174** and define a gap **176** therebetween.

[0078] The second portion **158** of the exemplary shield **112** includes inner and outer base members **178** and **180** as well as a plurality of flat members **182** that extend from the inner base member to the outer base member. The apertures **162** are located in the thickened regions **184** of the inner and outer base members **178** and **180**. In the illustrated implementation, the flat members **182** are arranged in groups **186** that include four flat members. The end groups **186a**, which are located on opposite sides of the gap **148**, include only three flat members **182**.

[0079] The respective configurations of the first and second shield portions **154** and **158** are such that when the first and second shield portions are brought together, the inner and outer base members **166** and **168** of the first shield portion will be aligned with the inner and outer base members **178** and **180**. In other implementations, the inner diameter of the first shield portion (as defined by the inner base members **166**) will be greater than the inner diameter of the second shield portion (as defined by the inner base member **178**) and the inner tabs **160** and apertures will be

omitted. Here, there will be a discontinuity (or gap) in the shield between the inner base members **166** and the inner base member **178**.

[0080] As alluded to above, the present antenna assemblies include those with shields that are configured to assist in the formation of the loops of the associated antenna and to maintain the antenna in the desired shape. To that end, and turning to FIGS. **18-21**, the exemplary antenna assembly **108b** is substantially similar to antenna assembly **108** and similar elements are represented by similar reference numerals. For example, the antenna assembly **108b** includes an antenna **110** and an electromagnetic shield (or "shield") **112b** that is essentially identical to the shield **112**. The shield **112b** has, for example, a first shield portion **154b** that defines an interior volume **156** for the antenna **110** and a second shield portion **158** that covers the open end of the interior volume. The first shield portion **154b** includes arch-shaped members **164** that are connected to inner and outer base members **166** and **168**. Alignment tabs **160b** and apertures **162** are also provided.

[0081] Here, however, the first shield portion **154b** includes antenna guides **188** and antenna guides **190**. In the illustrated implementation, each group **174** and **174a** includes one or more of the antenna guides **188** and one or more of the antenna guides **190**. The spacing between the antenna guides **188** and **190**, as well as the spacing between the antenna guides and the inner and outer base members **166** and **168**, is such that loop channels **192**, **194** and **196** are defined by the first shield portion **154b** within the interior volume **156**. Although the number of channels may vary, there are three loop channels **192-196** for the three-looped antenna **110**. The antenna **110** may be formed by, for example, guiding the inductor assembly **132** between the guides (or between the guides and base members) and around the channels **192-196** while pressing the inductor assembly into the channels. The guides **188** and **190** will then hold the antenna **110** in place and maintain its shape.

[0082] It should also be noted that it may be desirable in some instances to split an electromagnetic shield into two shield parts that are independently connected to the alignment posts **150** (FIG. **6**). To that end, and referring to FIGS. **22-24**, an electromagnetic shield **112c** may be formed from first and second shield portions **154c** and **158c**. The first shield portion **154c** includes parts **154c-1** and **154c-2**, while the second shield portion **158c** includes parts **158c-1** and **158c-2**. The first shield portion parts **154c-1** and **154c-2** are separated by gaps **176** and **176b**, while the second shield portion parts **158c-1** and **158c-2** are separated by gaps **148** and **148b**. In other implementations, the two shield parts that are disconnected at the gaps **148** and **148c** may be connected to a single tab **146**, which results in the shield being connected to a single one of the alignment posts **150** (FIG. **6**). Alternatively, the electromagnetic shield **112** may be reconfigured such that one of the tabs **146** is omitted, which results in the shield being connected to a single one of the alignment posts **150** (FIG. **6**).

[0083] With respect to materials and manufacture, suitable materials for the exemplary shield **112** include, but are not limited to, Nitinol and other electrically conductive biocompatible metals such as titanium, gold, and stainless steel. Nitinol is especially useful due to its flexibility and shape memory properties. The first and second shield portions **154** and **158** (as well as the other shield portions described herein) may be formed through etching or other suitable fab-

rication processes. The first shield portion 154 may be initially flat, and then formed into the illustrated three-dimensional shape with a die.

[0084] One exemplary method of assembling the exemplary antenna assembly 108 is illustrated in FIGS. 25-29. The first shield portion 154 of the shield 112 is placed into a fixture 200 (FIG. 25) that includes a cavity 202, shield support 204 and antenna guides 206. The fixture 200 is configured to hold the first and second shield portions 154 and 158, as well as the antenna 110, during the assembly process. The open end of the first shield portion interior volume 156 faces upwardly (in the illustrated orientation), as do the tabs 160. When the first shield portion 154 is fully inserted and the arch-shaped members 164 rest on the supports 204 (FIG. 26), the antenna guides 206 will extend through the spaces between the arch-shaped members and into the interior volume 156. The antenna guides 206 together define loop channels (not shown) in a manner similar to that described above with reference to FIGS. 18-21. The inductor assembly 132 may then be pressed into the loop channels (FIG. 27) to form the antenna 110 within the interior volume 156 of the first shield portion 154 (FIG. 28). The antenna 110 is oriented relative to the first shield portion 154 in the manner illustrated in FIGS. 11 and 13. The second shield portion 158 may then be placed onto the first shield portion 154 (FIGS. 28 and 29) in such a manner that the tabs 160 on the first shield portion extend through the apertures 162 on the second shield portion in the manner illustrated in FIG. 6 and align the shield portions with one another. The first and second shield portions 154 and 158 may then be secured to one another to form the shield 112 and complete the antenna assembly 108. For example, a laser welding tool LW (or other welding tool) may be used to bond the first and second shield portions 154 and 158 to one another at one or more of the thickened regions 184 where the tabs 160 pass through the apertures 162 and/or at other regions around the outer perimeter of the shield.

[0085] In some instances, in order to ensure that the antenna 110 is maintained in the desired shape after the antenna assembly 108 is removed from the fixture 200, the fixture may also be used as mold. Referring to FIG. 30, a mold cover 208 may be positioned over the cavity 202 and overmold material (e.g., silicone or other suitable materials) may be injected into the cavity to form an overmold 198 (FIG. 30A) over the antenna assembly 108.

[0086] As discussed above with reference to FIG. 10, the exemplary antenna assembly 108 may, but for the free ends of the inductor assembly 132, include an overmolded antenna holder 111 that will maintain the antenna 110 in the desired shape and protect the antenna assembly during storage and subsequent assembly of the cochlear implant 100. Here, the fixture does not need the antenna guides 206, and the fixture 200a (FIG. 31) is identical to the fixture 200 but for the omission of the antenna guides. After the first shield portion 154 has been placed into the fixture 200a, the antenna 110 (with holder 111) may simply be inserted in the and into the interior volume 156 (FIG. 32). The second shield portion 158 may then be positioned on, and secured to, the first shield portion 154 in the manner described above with reference to FIGS. 28 and 29 to complete the antenna assembly.

[0087] The exemplary shield 112b illustrated in FIGS. 18-21 may be assembled by, for example, placing the shield portion 154b into the fixture 200a and forming the inductor

assembly 132 into the antenna 110 using the above described antenna guides 188 and antenna guides 190, as illustrated in FIGS. 33 and 34. The second shield portion 158 may then be positioned on, and secured to, the first shield portion 154 in the manner described above with reference to FIGS. 28 and 29 to complete the antenna assembly. An overmold (not shown) may be formed over the antenna assembly.

[0088] Another exemplary cochlear implant is the cochlear implant 200 illustrated in FIGS. 35-37. The cochlear implant 200 is substantially similar to cochlear implant 100 and similar elements are represented by similar reference numerals. The cochlear implant 200 includes a flexible housing 102 formed from a silicone elastomer or other suitable material, a processor assembly 104, a cochlear lead 106, and an antenna assembly 208 with an antenna coil (or "antenna") 110 and an electromagnetic shield (or "shield") 212. The antenna 110, which is discussed in greater detail above with reference to FIGS. 3-9, may be used to receive data and power by way of an external antenna that is associated with, for example, a sound processor unit, while the electromagnetic shield 212 functions in a manner similar to the electromagnetic shields in other hearing related devices. As discussed above, the cochlear lead 106 may include a flexible body 114, an electrode array 116 at one end of the flexible body, and a plurality of wires (not shown) that extend through the flexible body from the electrodes 118 (e.g., platinum electrodes) in the array 116 to the other end of the flexible body. A positioning magnet 120 is located within a region encircled by the antenna assembly 208 (e.g., within an internal pocket 122 defined by the housing 102). The antenna assembly 208 has an overall annular shape with an open central region 113 to accommodate the magnet 120 and magnet pocket 122. An opening 124 allows the magnet 120 to be removed from the internal pocket 122 if necessary. The exemplary processor assembly 104, which is connected to the electrode array 116 and antenna 110, includes a printed circuit board 126 with a stimulation processor 128 that is located within a hermetically sealed case 130. The case 130 may be formed from titanium or other suitable materials. The stimulation processor 128 converts the stimulation data into stimulation signals that are transmitted to the cochlea by way of the electrodes 118 of the electrode array 116. The exemplary antenna 100a, which is described above with reference to FIGS. 7-9, may also be employed in the antenna assembly 208. In those instances where an antenna 110 (or 110a) will not self-maintain the three concentric loops shape illustrated in FIG. 36 or other desired shape, an overmolded antenna holder 111 (discussed above with reference to FIG. 10) may be employed. The antenna holder 111 will be positioned within the shield 212 along with the antenna 110 (or 110a).

[0089] As illustrated in FIG. 37, the exemplary shield 212 includes a pair of conductive rings 248. The conductive rings 248 are welded or otherwise connected to the titanium case 130, and the case is connected to ground circuitry within the case. In the illustrated implementation, the case 130 includes a pair of alignment posts 150 that extend through the conductive rings 248 and orient shield 212 relative to the case.

[0090] As illustrated in FIGS. 38 and 39, the exemplary shield 212 is part of a shield assembly 252 that also includes a flexible, electrically non-conductive shield carrier 254. The shield carrier 254 and the shield 212 may be wrapped

around the antenna 110 to form the antenna assembly 208 in the manner described below with reference to FIGS. 40-47.

[0091] Turning to FIGS. 40-43, which show the shield assembly 252 in its pre-wrapping, unstressed state, the exemplary shield carrier 254 includes a base member 256, the connector tab 257, and a plurality of separately bendable projections 258 that extend outwardly from base member. In the illustrated implementation, the base member 256 has an annular shape, while the separately bendable projections 258 are separated by gaps 260 and extend radially outwardly from the base member. The shield carrier 254 also includes areas of increased flexibility 262 and 264 (as compared to adjacent portions of the shield carrier) which correspond to locations where the separately bendable projections 258 will be bent as the shield assembly 252 is wrapped around the antenna. The areas of increased flexibility 262 and 264 may be in the form of, for example, apertures (as shown), areas of reduced thickness, chemically treated areas.

[0092] The exemplary shield 212 includes a plurality of initially disconnected shield segments 266 that are spaced apart from one another and electrically disconnected from one another when the shield assembly 252 is in the pre-wrapping, unstressed state illustrated in FIGS. 40 and 41. The ends of the shield segments 266 include contact pads 268 and 270. In the illustrated implementation, the separately bendable projections 258 include a pair of shield segments 266-1 and 266-2. The ends of the shield segments 266-1 and 266-2 include contact pads 268-1 and 268-2 as well as contact pads 270-1 and 270-2. As is also discussed below with reference to FIGS. 44 and 45, adjacent shield segments are electrically connected to one another during the assembly process when a contact from one shield segment is brought into contact with, and is welded or otherwise bonded and electrically connected to, a contact from another shield segment. For example, after a separately bendable projection 258 has been bent, the contact pad 268-1 on one shield segment is brought into contact with, and is welded or otherwise bonded and electrically connected to, the contact pad 270-1 from the adjacent shield segment (on the adjacent projection 258), while the contact pad 268-2 on the other shield segment of the bent projection 258 is brought into contact with, and is welded or otherwise bonded and electrically connected to, the contact pad 270-2 from the adjacent shield segment (on the same projection 258). Alignment may be facilitated through the use of alignment apertures 272 and 274 that may be pushed over posts on the assembly fixture.

[0093] The conductive rings 248-1 and 248-2 (FIG. 41) on the connector tab 257 may be connected to the shield 212 by way of conductors 276-1 and 276-2 and contact pads 270-1 and 268-2. During the assembly process, the contact pads 270-1 and 268-2 will be respectively connected to contact pads 268-1 and 268-2 of the projections 258 that are located on opposite sides of the connector tab 257.

[0094] With respect to manufacture and materials, the exemplary shield carrier 254 may include first and second individual flexible substrate layers 278 and 280 (FIGS. 42 and 43) that are laminated together. The flexible substrate layers 278 and 280 may be formed from flexible biocompatible materials including, but not limited to, polyimides and liquid crystal polymers. The flexible biocompatible material may be transparent (as is shown for explanatory purposes), translucent or opaque. Electrical traces are deposited onto the substrate layer 278 to form the shield segments

266 and conductors 276. The traces may, for example, be formed from a noble metal such as gold or a gold alloy that is deposited using methods such as plating, sputtering, vapor deposition, and shaped using methods such as chemical etching and laser ablation. The traces may also include a thin adhesion layer (e.g., titanium or platinum) that strongly binds with both the polyimide and the noble metal deposited over the adhesion layer. The contact pads 268 and 270 may be vias formed from similar metals that pass through the first and second substrate layers 278 and 280 at the ends of the shield segments. In other implementations, the contact pads 268 and 270 may be part of the electrical traces that are exposed by etching or other suitable processes. It should also be noted that the number of substrate layers, as well as the manner in which the shield is formed, may be adjusted as necessary or desired.

[0095] With respect to assembly of the exemplary shield assembly 252, the shield carrier 254, including the shield segments 266 and contacts 268 and 270, may be placed on a fixture, such as the exemplary fixture 200 illustrated in FIGS. 44 and 45. The fixture includes a base 202 and a plurality of posts 204 that extend through the alignment apertures 274. The antenna 110 may be placed onto the shield carrier 254 before or after the shield carrier has been placed on the fixture 200. Each separately bendable projection 258 may then be bent in the direction of arrows A (or "wrapped") around the adjacent portion of the antenna 110 into the wrapped, stressed state illustrated in FIGS. 46 and 47. The antenna 110 is omitted from FIGS. 46 and 47 to facilitate observation of the shield assembly 252. The base 256 and portions of the bendable projections 258 that are located above and below the antenna 110 (in the illustrated orientation) are flat. The areas of increased flexibility 262 and 264 are located at the inner and outer edges of the antenna 110 where the bending primarily occurs. Placing the alignment apertures 272 over the posts 204 aligns the contact pads 268 at one end of the shield segments 266 with the contact pads 270 at the other end to connect the shield segments to one another in series, thereby forming the shield 212. In particular, and referring more specifically to FIG. 47, the contact pad 268-1 on the shield segment 266-1 of a bent projection 258 will be aligned with the contact pad 270-1 from the adjacent shield segment (on the adjacent projection 258), while the contact pad 268-2 on the shield segment 266-2 of the bent projection will be aligned with the contact 270-2 from the adjacent shield segment (on the same projection 258). The aligned contacts 268-1 and 270-1 may be electrically connected to one another through the use of methods such as, for example, welding (resistance or laser) and gold bond ball bonding. A weld 282-1 is employed in the illustrated implementation. The aligned contacts 268-2 and 270-2 are electrically connected with a weld 282-2. This process may be repeated for each of the bendable projections 258 to complete the shield 212 and to connect the shield to the conductive rings 248.

[0096] As discussed above with reference to FIG. 10, an overmolded antenna holder 111 may be used to maintain the antenna 110 in the desired shape. Here, the antenna 110 (with holder 111) may be placed onto the shield carrier 254 in the manner illustrated in FIG. 48. The shield 212 may then be formed in manner described above with reference to FIGS. 44-47.

[0097] It should also be noted that it may be desirable in some instances to split an electromagnetic shield 212 into

two shield parts that are independently connected to the alignment posts 150 (FIG. 37). Such separation may be accomplished in a number of ways. For example, and referring to FIG. 49, the exemplary shield assembly 252a is substantially similar to the shield assembly 252 and similar elements are represented by similar reference numerals. For example, the shield assembly 252a includes a shield carrier 254, with a base member 256 and a plurality of separately bendable projections 258, and a plurality of initially disconnected shield segments 266 with contact pads 268 and 270. Here, however, the bendable segment 258a does not include shield segments 266. As a result, when the bending and welding process described above is complete (including the bendable segment 258a and associated contact pads 268 and 270), the resulting shield will have two portions that are disconnected at the bendable segment 258a. Alternatively, one of the bendable segments 258, as well as the associated shield segments 266 and contact pads 268 and 270, may simply be omitted. In other implementations, the two portions that are disconnected at the bendable segment 258a may be connected to the same conductive ring (e.g., conductive ring 248-1 in FIG. 41), which results in the shield being connected to a single one of the alignment posts 150 (FIG. 37). Alternatively, the shield assembly 252 may be reconfigured such that one of the conductive rings 248 is omitted (e.g., conductive ring 248-1 in FIG. 41), which results in the shield being connected to a single one of the alignment posts 150 (FIG. 37).

[0098] Another exemplary cochlear implant is the cochlear implant 300 illustrated in FIGS. 50-52. The cochlear implant 300 is substantially similar to cochlear implant 100 and similar elements are represented by similar reference numerals. The cochlear implant 300 includes a flexible housing 102 formed from a silicone elastomer or other suitable material, a processor assembly 104, a cochlear lead 106, and an antenna assembly 308 with an antenna coil (or “antenna”) 110 and an electromagnetic shield (or “shield”) 312. The antenna 110, which is discussed in greater detail above with reference to FIGS. 3-9, may be used to receive data and power by way of an external antenna that is associated with, for example, a sound processor unit, while the electromagnetic shield 312 functions in a manner similar to the electromagnetic shields in other hearing related devices. As discussed above, the cochlear lead 106 may include a flexible body 114, an electrode array 116 at one end of the flexible body, and a plurality of wires (not shown) that extend through the flexible body from the electrodes 118 (e.g., platinum electrodes) in the array 116 to the other end of the flexible body. A positioning magnet 120 is located within a region encircled by the antenna assembly 308 (e.g., within an internal pocket 122 defined by the housing 102). The antenna assembly 308 has an overall annular shape with an open central region 113 to accommodate the magnet 120 and magnet pocket 122. An opening 124 allows the magnet 120 to be removed from the internal pocket 122 if necessary. The exemplary processor assembly 104, which is connected to the electrode array 116 and antenna 110, includes a printed circuit board 126 with a stimulation processor 128 that is located within a hermetically sealed case 130. The case 130 may be formed from titanium or other suitable materials. The stimulation processor 128 converts the stimulation data into stimulation signals that are transmitted to the cochlea by way of the electrodes 118 of the electrode array 116. The exemplary antenna 100a,

which is described above with reference to FIGS. 7-9, may also be employed in the antenna assembly 308. In those instances where an antenna 110 (or 110a) will not self-maintain the three concentric loops shape illustrated in FIG. 36 or other desired shape, an overmolded antenna holder 111 (discussed above with reference to FIG. 10) may be employed. The antenna holder 111 will be positioned within the shield 312 along with the antenna 110 (or 110a).

[0099] As illustrated in FIG. 52, the exemplary shield 312 includes a pair of conductive curved ends 348, which may be formed before or during the assembly process. The curved ends 348 are welded or otherwise connected to the titanium case 130, and the case is connected to ground circuitry within the case. In the illustrated implementation, the case 130 includes a pair of alignment posts 150 that extend through the curved ends 348 and orient shield 312 relative to the case. It should also be noted that the curved ends 348 in the illustrated embodiment are at the free ends of a continuous wire (or other elongate structure), which results in a shield 312 that can be held and/or manipulated from the ends thereof during assembly, as opposed to completely closed circle.

[0100] Turning to FIGS. 53-55, the exemplary shield 312 has an overall annular shape and is configured in such a manner that it does not form a continuous loop around the antenna 110 (or 110a). As used herein, a shield that does form a continuous loop around an antenna (i.e., forms a “discontinuous loop around the antenna”) is a shield that follows an uninterrupted path, without reversal of direction, a plurality of times around the antenna. For example, a shield wire that is wound repeatedly around an antenna will form a continuous somewhat helical shape around the antenna. When formed from a resilient material (e.g., a wire formed from a super-elastic material such as Nitinol or a less elastic resilient material), the discontinuity of the present discontinuous loop results in an openable shield that may be provided pre-set in its final shape, then deformed in such a manner that the antenna can be inserted into the shield through an opening enlarged by the deformation (of a size sufficient to receive the antenna), and then released from the deforming force whereby the resilience of the shield will return the shield to its pre-set shape.

[0101] In the exemplary implementation illustrated in FIGS. 53-55, the shield 312 includes a plurality of shield portions 314, each of which includes a pair of elongate members 316 that are connected to one another by an inner perimeter portion 318 (e.g., the illustrated U-shaped inner perimeter portion 318). The inner perimeter portions 318, which are perpendicular to the elongate member 316, together define the inner perimeter of the shield 312. The shield portions 314 also include outer perimeter portions 320 (e.g., the illustrated curved outer perimeter portions 320) that define the outer perimeter of the shield 312. Adjacent shield portions 314 are connected to one another in series by their respective outer perimeter portions 320. With reference to the associated antenna 110, the elongate members 316 extend generally in the radial direction R, the U-shaped inner perimeter portions 318 extend generally in directions that are tangential to the inner peripheral surface of the antenna 110, and the outer perimeter portions 320 extend around the outer peripheral surface of the antenna. The elongate members 316 of adjacent shield portions 314 are located on opposite sides of the antenna 110. The U-shaped inner perimeter portions 318 of adjacent shield portions 314

extend in opposite directions and are spaced apart from one another with gaps 322 therebetween. Put another way, the orientation of each shield portion 314 is the opposite of the orientation of the adjacent shield portions.

[0102] The gaps 322 between adjacent shield portions 314 in the illustrated embodiment together define an undulating opening that extends along the inner perimeter of the shield 312. The interior volume 324 for the antenna 110 is defined by the shield portions 314. Additionally, as noted above, the shield 312 may be formed from Nitinol (e.g., Nitinol wire), other super-elastic materials (including wires formed therefrom), or other resilient materials such as DFT or stainless steel wire that resist plastic deformation when the shield is stretched in the manner described below. In addition to the above described shape memory benefits, the use of super-elastic material improves the impact resistance of the shield.

[0103] With respect to the dimensions of the exemplary shield 312, which has an inner diameter of about 19.0 mm and an outer diameter of about 27.0 mm, the shield portions 314 have an outer perimeter width $W1$ of about 3.5 mm (FIG. 55) and an inner perimeter width of about 1.8 mm. The angle $\theta 1$ defined by the elongate members 316 of the same shield portion 314 is about 25° and the angle $\theta 2$ between the elongate members 316 of adjacent shield portions 314 is about 10° . As used herein, the word about means $\pm 10\%$.

[0104] The antenna assembly 308 may be assembled in, for example the manner illustrated in FIGS. 56-59. The shield 312 is shown in its pre-set shape in FIGS. 56 and 57. Forces $F1$ may be applied to some or all of the shield 312 to stretch the shield (or a portion thereof) out of its pre-set shape and increase the distance between adjacent shield portions 314. In particular, the space between adjacent inner perimeter portions 318 is increased, thereby increasing the size of the gaps 322. Alternatively, or in addition, forces $F2$ may be applied in the manner illustrated in FIG. 58 to stretch the shield out of its pre-set shape and increase the distance between adjacent shield portions 314 and, in particular, between inner perimeter portions 318, thereby increasing the size of the gaps 322. Once the shield 312 has been manipulated out of its pre-set shape, the antenna 110 may be inserted into the interior volume 224 through the now larger gaps 322 that together defining an opening that is coextensive with the inner perimeter of the shield (FIGS. 57 and 58). The forces (e.g., forces $F1$ and/or $F2$) may then be removed to allow the shield to return to its pre-set shape. For example, different portions of the shield may be serially manipulated out of the pre-set shape, as different portions of the antenna 110 are serially inserted into the interior volume 224 through the now larger gaps 322, and then allowed to return to the pre-set shape. This process may continue until the antenna 110 is entirely within the shield 312 in the manner illustrated in FIGS. 53 and 59.

[0105] It should also be noted that, in other implementations, the shield may be provided with an opening for the antenna in places other than the inner perimeter. For example, the configuration of the shield may be such that the opening for the antenna is located along the outer perimeter or is located between the inner and outer perimeters.

[0106] The present inventions have application in a wide variety of systems including, but not limited to, those that provide sound (i.e., either sound or a perception of sound) to the hearing impaired. One example of such a system is an ICS system where an external sound processor communicates with a cochlear implant. Turning to FIG. 60, the

exemplary cochlear implant system 50 includes the cochlear implant 100 (or 200 or 300), a sound processor, such as the illustrated body worn sound processor 400 or a behind-the-ear sound processor, and a headpiece 500.

[0107] As noted above with reference to FIG. 1, the exemplary cochlear stimulator 100 illustrated in FIG. 60 includes a flexible housing 102 formed from a silicone elastomer or other suitable material, a processor assembly 104, a cochlear lead 106 with an electrode array, an antenna assembly 108, and a positioning element 120.

[0108] The exemplary body worn sound processor 400 includes a housing 402 in which and/or on which various components are supported. Such components may include, but are not limited to, sound processor circuitry 404, a headpiece port 406, an auxiliary device port 408 for an auxiliary device such as a mobile phone or a music player, a control panel 410, one or more microphones 412, and a power supply receptacle 414 for a removable battery or other removable power supply 416 (e.g., rechargeable and disposable batteries or other electrochemical cells). The sound processor circuitry 404 converts electrical signals from the microphone 412 into stimulation data. The exemplary headpiece 500 includes a housing 502 and various components, e.g., a RF connector 504, a microphone 506, an antenna (or other transmitter) 508 and a disk-shaped positioning magnet 510, that are carried by the housing. The headpiece 500 may be connected to the sound processor headpiece port 406 by a cable 512. The positioning magnet 510 is attracted to the magnet 120 of the cochlear stimulator 100, thereby aligning the antenna 508 with the antenna of the antenna assembly 108.

[0109] The stimulation data and, in many instances power, is supplied to the headpiece 500. The headpiece 500 transcutaneously transmits the stimulation data, and in many instances power, to the cochlear implant 100 by way of a wireless link between the antennas. The stimulation processor 128 (FIG. 1) converts the stimulation data into stimulation signals that stimulate the electrodes of the electrode array on the cochlear lead 106.

[0110] In at least some implementations, the cable 512 will be configured for forward telemetry and power signals at 49 MHz and back telemetry signals at 10.7 MHz. It should be noted that, in other implementations, communication between a sound processor and a headpiece and/or auxiliary device may be accomplished through wireless communication techniques. Additionally, given the presence of the microphone(s) 412 on the sound processor 400, the microphone 506 may be also be omitted in some instances. The functionality of the sound processor 400 and headpiece 500 may also be combined into a single head wearable sound processor. Examples of head wearable sound processors are illustrated and described in U.S. Pat. Nos. 8,811,643 and 8,983,102, which are incorporated herein by reference in their entirety.

[0111] Although the inventions disclosed herein have been described in terms of the preferred embodiments above, numerous modifications and/or additions to the above-described preferred embodiments would be readily apparent to one skilled in the art. By way of example, the inventions also include any combination of the elements from the various species and embodiments disclosed in the specification that are not already described. It is intended that the scope of the present inventions extend to all such modifications and/or

additions and that the scope of the present inventions is limited solely by the claims set forth below.

1-41. (canceled)

42. An antenna assembly for use with a medical implant, the antenna assembly comprising:

an antenna that defines at least one turn; and
an electromagnetic shield that forms a discontinuous loop around the antenna.

43. An antenna assembly as claimed in claim **42**, wherein the electromagnetic shield is formed from resilient shape memory material and has a pre-set shape.

44. An antenna assembly as claimed in claim **43**, wherein the electromagnetic shield defines an inner perimeter and an opening that extends along the inner perimeter of the electromagnetic shield.

45. An antenna assembly as claimed in claim **44**, wherein the opening comprises an undulating opening.

46. An antenna assembly as claimed in claim **44**, wherein the opening is configured to increase in size when the electromagnetic shield is stretched out of the pre-set shape.

47. An antenna assembly as claimed in claim **42**, wherein the electromagnetic shield includes a plurality of shield portions that are connected to one other in series.

48. An antenna assembly as claimed in claim **47**, wherein the shield portions each include first and second elongate members and an inner perimeter member that connects the first and second elongate members to one another.

49. An antenna assembly as claimed in claim **48**, wherein the inner perimeter members of adjacent shield portions extend in opposite directions.

50. An antenna assembly as claimed in claim **49**, wherein the inner perimeter members comprise U-shaped members.

51. An antenna assembly as claimed in claim **47**, wherein the inner perimeter of the electromagnetic shield includes gaps between adjacent shield portions.

52. An antenna assembly as claimed in claim **48**, wherein the shield portions have an outer perimeter width of about 3.5 mm and an inner perimeter width of about 1.8 mm,

an angle defined by the elongate members of the same shield portion is about 25°, and an angle between the elongate members of adjacent shield portions is about 10°.

53. An antenna assembly as claimed in claim **42**, wherein the antenna includes a conductor and an electrically non-conductive carrier defining a lumen in which the conductor is located.

54. An antenna assembly as claimed in claim **53**, wherein the conductor includes a plurality of twisted wires.

55. An antenna assembly as claimed in claim **53**, wherein the conductor comprises a plurality of conductors and the lumen comprises a plurality of lumens in which the plurality of conductors are respectively located.

56. An antenna assembly as claimed in claim **42**, wherein the antenna is located within an overmolded antenna holder.

57. A method, comprising the steps of:

deforming at least a portion of an electromagnetic shield with a pre-set overall annular shape in such a manner that a perimeter opening of the electromagnetic shield is enlarged; and

inserting a portion of a medical implant antenna defining at least one turn into the deformed portion of the electromagnetic shield by way of the enlarged perimeter opening.

58. A method as claimed in claim **57**, further comprising the step of:

allowing the deformed portion of the electromagnetic shield to return to the pre-set shape after the portion of the medical implant antenna has been inserted into the electromagnetic shield.

59. A method as claimed in claim **57**, further comprising the step of:

repeating the deforming, inserting and allowing steps.

60. A method as claimed in claim **57**, wherein the perimeter comprises an inner perimeter.

* * * * *