

(19)  
(12)

(KR)  
(B1)

(51) 。 Int. Cl. <sup>7</sup>  
G01R 1/067

(45)  
(11)  
(24)

2002 08 28  
10 - 0350513  
2002 08 16

(21) 10 - 2000 - 0017397  
(22) 2000 04 03

(65) 2001 - 0094032  
(43) 2001 10 31

(73) 2 854 103 1311

(72) 2 854 103 1311

(74)  
:

(54)

(PLASMA DISPLAY PANEL; "PDP" )  
, (1) (3) (4)가 PDP (2)  
, PDP (2) (3) , PDP (2)

2

1

2

3

4 ,  
 5 3 ,  
 <  
 1 : , 2 : ,  
 3 : , 4 : ,  
 5 : , 6 : ,  
 7 : , 8 : ,  
 8a : , 9 : , 10 ; .

(PLASMA DISPLAY PANEL; "PDP" )

PDP , PDP ,  
 PDP .  
 가 , 가  
 + - (probe; 探針)  
 , , 80μm , 150μm  
 , 가 ±10μm , 가  
 , PDP 가가 가 . 가  
 , PDP , 가 ,  
 , PDP 가 . 가 ,

가 ; PDP 가 PDP

가 PDP

1 2 , "ㄷ" (6) ; (6)  
 가 , PDP (2) (3) ; (6)  
 (3) (1) ; (3)가 PDP (2)  
 , (3) (4)가 PDP (2)

PDP , + - (10)  
 (10) PDP (2) , PDP (2) (10)  
 (1) , (1)가 , (10) (3)가

, PDP ( 3 "b" ) , (4) (a) , PDP  
 (b)가 , (3) (4)가 (2) , (2) (4)  
 , (10)  
 (3) (4)가 (2) , (10) (3) (2) 가 ,  
 , (2) 가  
 A/D , ( )  
 , (2)

(3) , 4 , (2) (4)가  
 가 (2) , (2) 가 , (2)  
 , (2) , (4)가 (2)

, 5 가 , (3) (4)가 3 (2) (2)

, 1 2 , (1) (3) (8) , (6)  
 (8) (9) , PDP ( )  
 (1) , (3)

, (1)  
 가 , "5" (6) (3) (5) , "7"  
 (1) (3)

가 PDP , PDP , PDP 가 PDP  
 , PDP , PDP , PDP 가  
 가 , PDP 가 , 가

(57)

1.

(6) ; (6) 가 , PDP (2) (3)  
 ; (6) (3) (1) ; (3)가 PDP (2)  
 , (3) (4)가 PDP (2)

2.

1 , (1) (3) (8) , (8)  
 (9) (6)

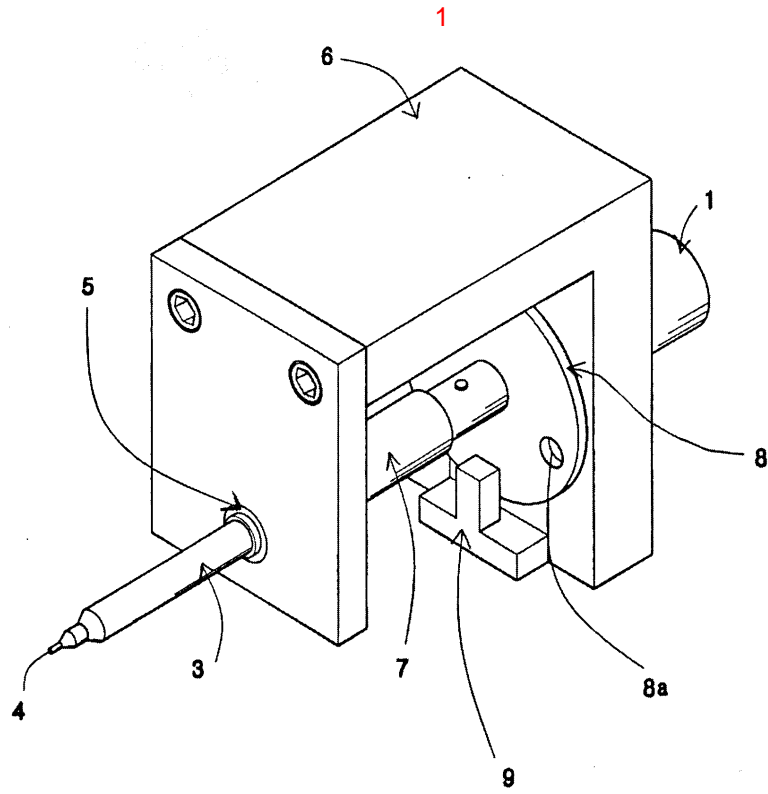

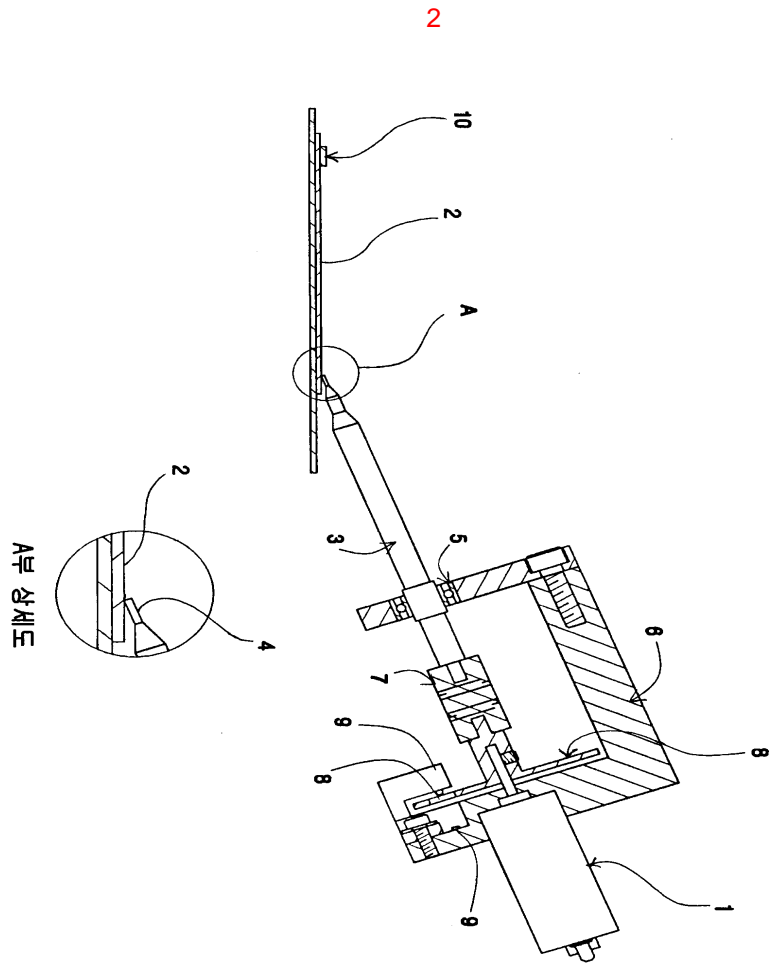

2

