



(19) **United States**

(12) **Patent Application Publication**
AIGLSTORFER

(10) **Pub. No.: US 2015/0012916 A1**

(43) **Pub. Date: Jan. 8, 2015**

(54) **SYSTEMS AND METHODS FOR EXECUTING AN APPLICATION ON A MOBILE DEVICE**

Publication Classification

(71) Applicant: **MFOUNDRY, INC.**, Jacksonville, FL (US)

(51) **Int. Cl.**
G06F 9/445 (2006.01)
G06F 9/45 (2006.01)
G06F 9/44 (2006.01)

(72) Inventor: **Rodney AIGLSTORFER**, Mill Valley, CA (US)

(52) **U.S. Cl.**
CPC .. *G06F 8/65* (2013.01); *G06F 8/71* (2013.01); *G06F 8/41* (2013.01)

(21) Appl. No.: **14/273,893**

USPC **717/171**

(22) Filed: **May 9, 2014**

(57) **ABSTRACT**

Related U.S. Application Data

The invention provides a method and system to execute applications on a mobile device. The applications may be compiled on a remote server and sent to the mobile device before execution. The applications may be updated by the remote server without interaction by the mobile device user.

(63) Continuation of application No. 11/943,963, filed on Nov. 21, 2007, now Pat. No. 8,811,968.

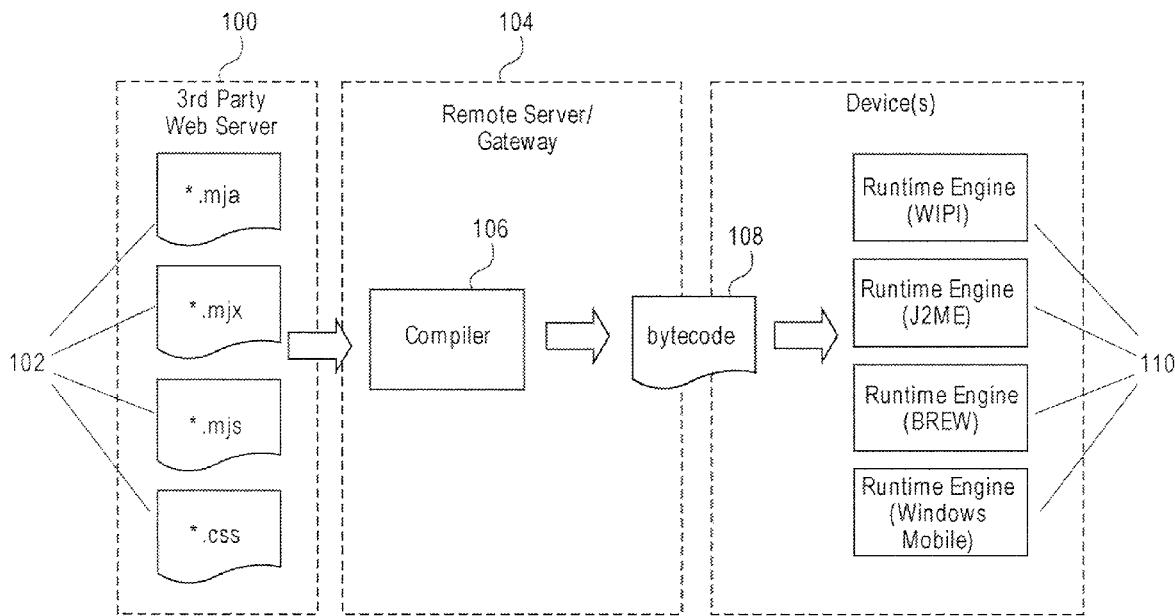

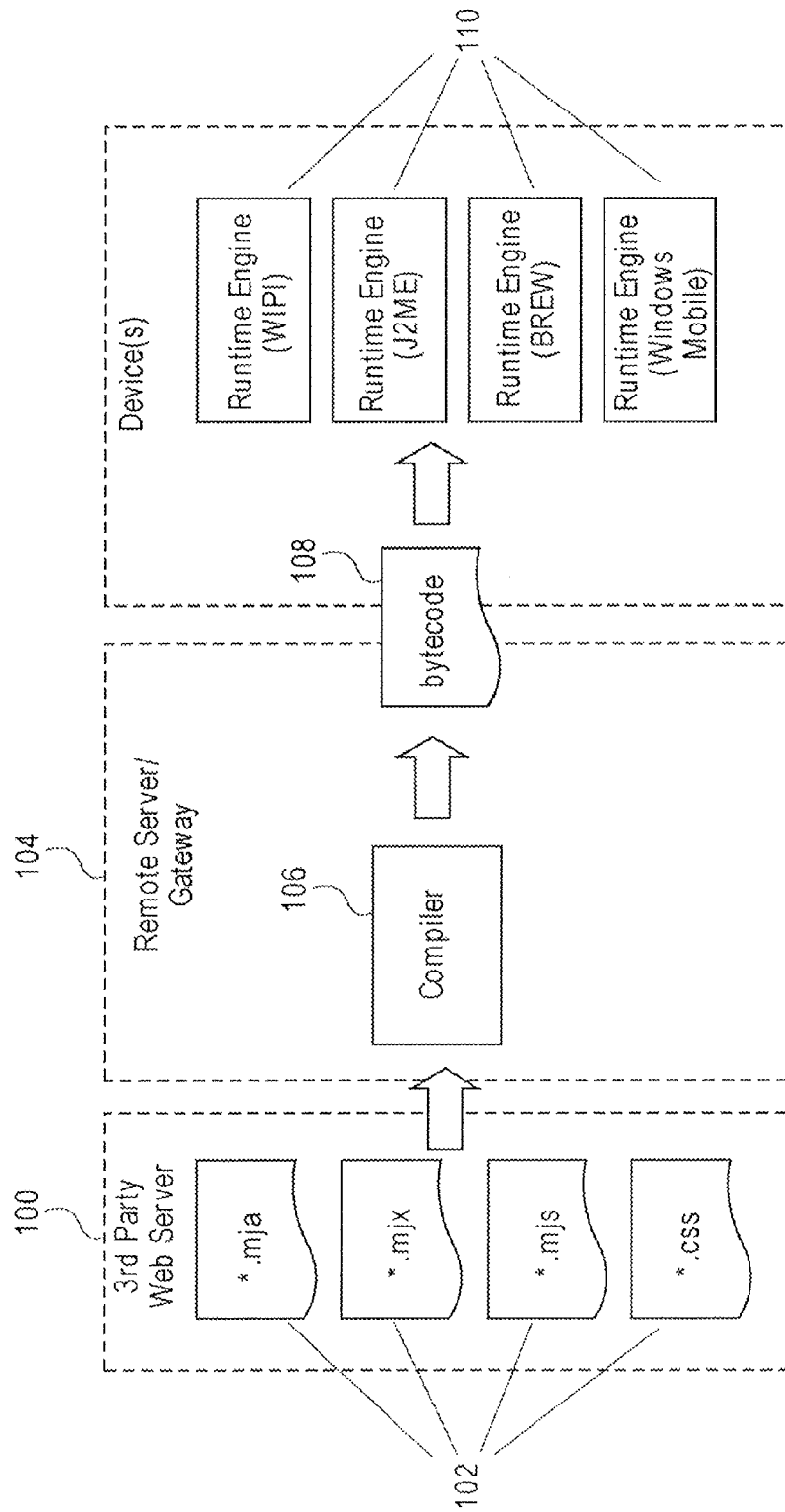

FIG. 1

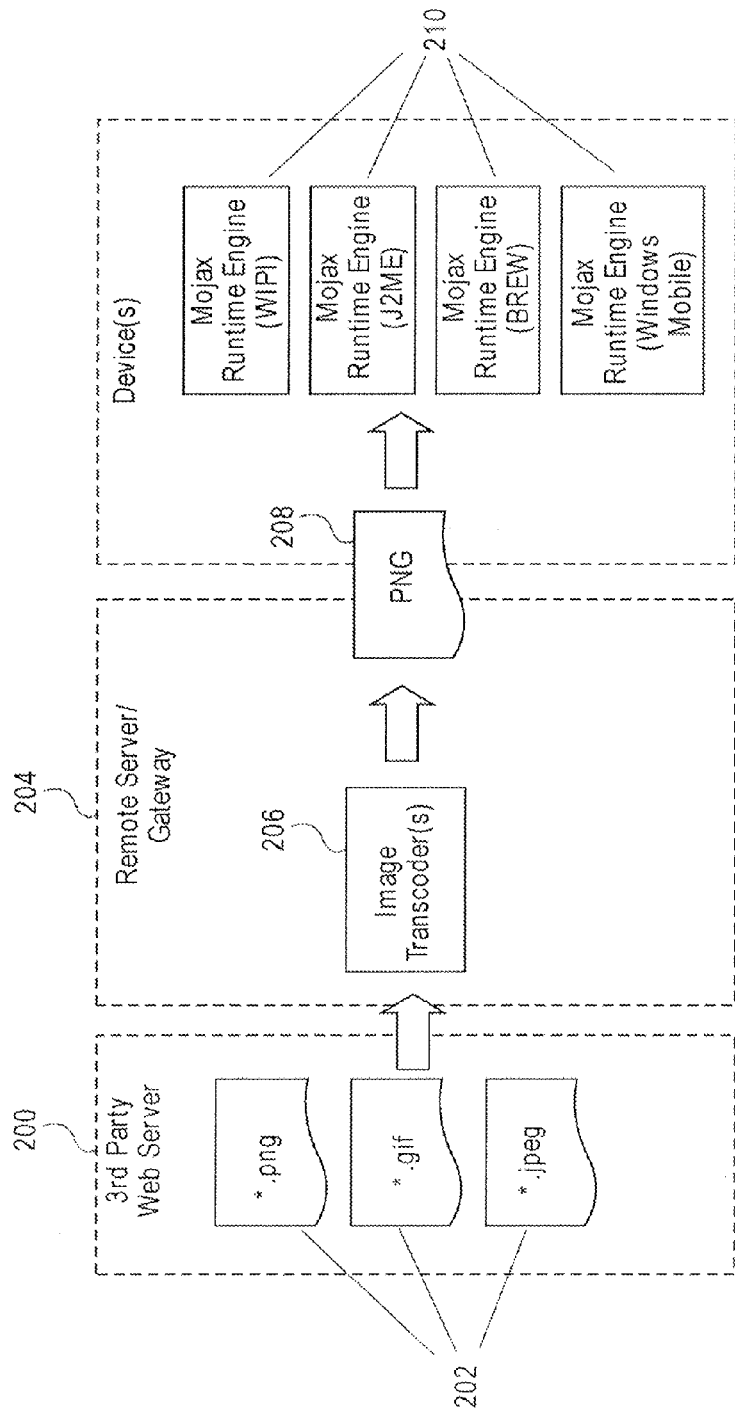

FIG. 2

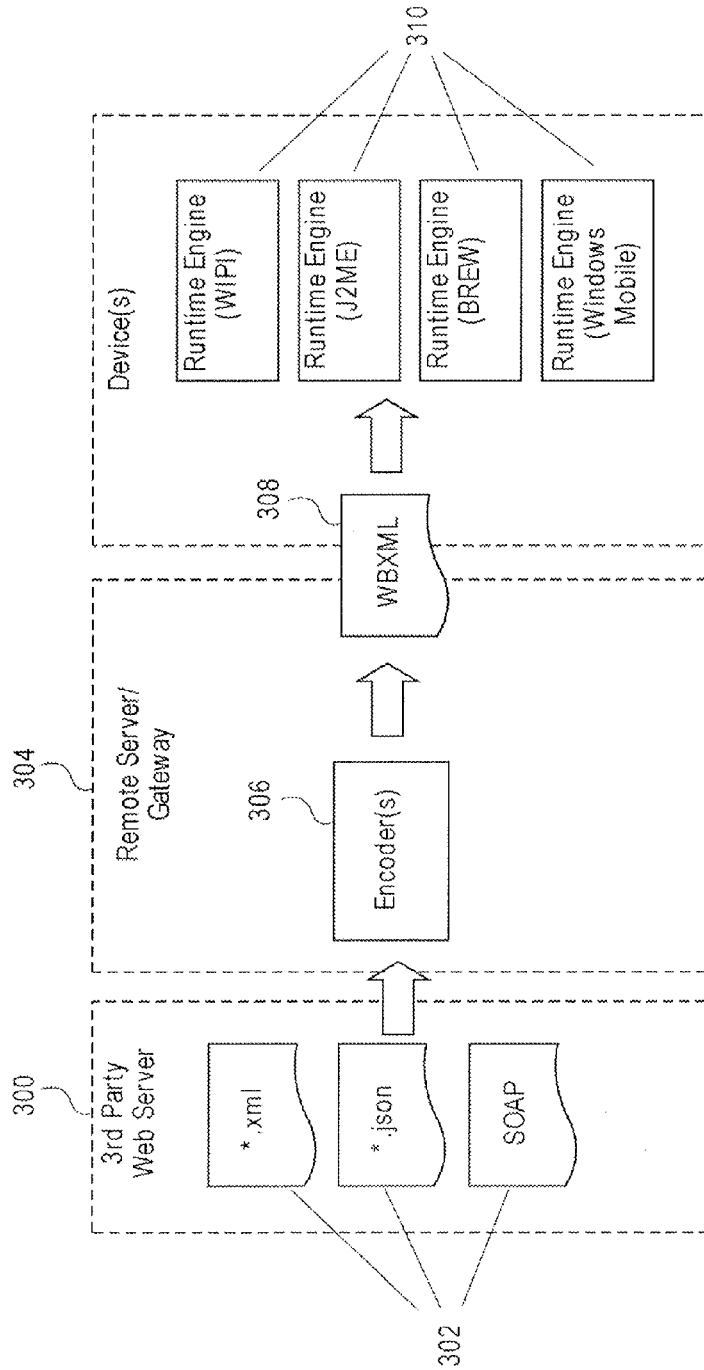

FIG. 3

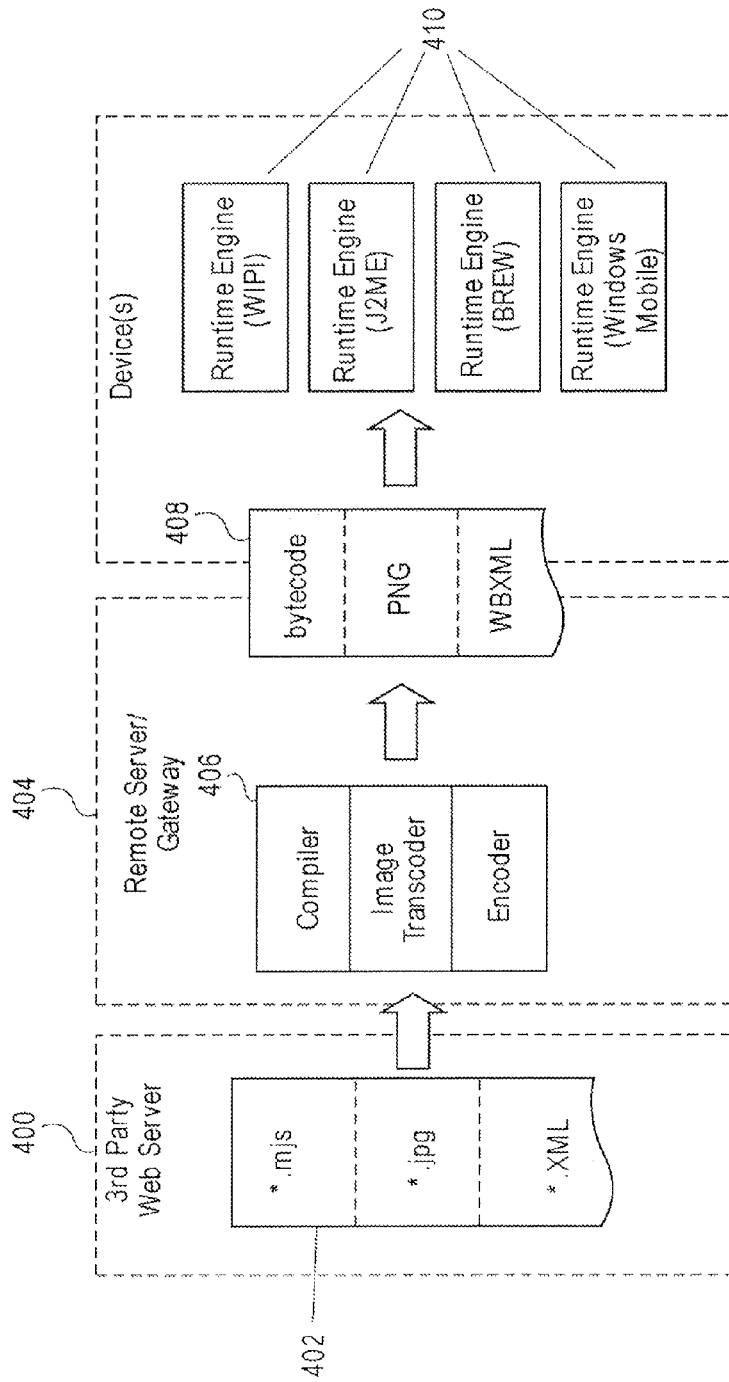

FIG. 4

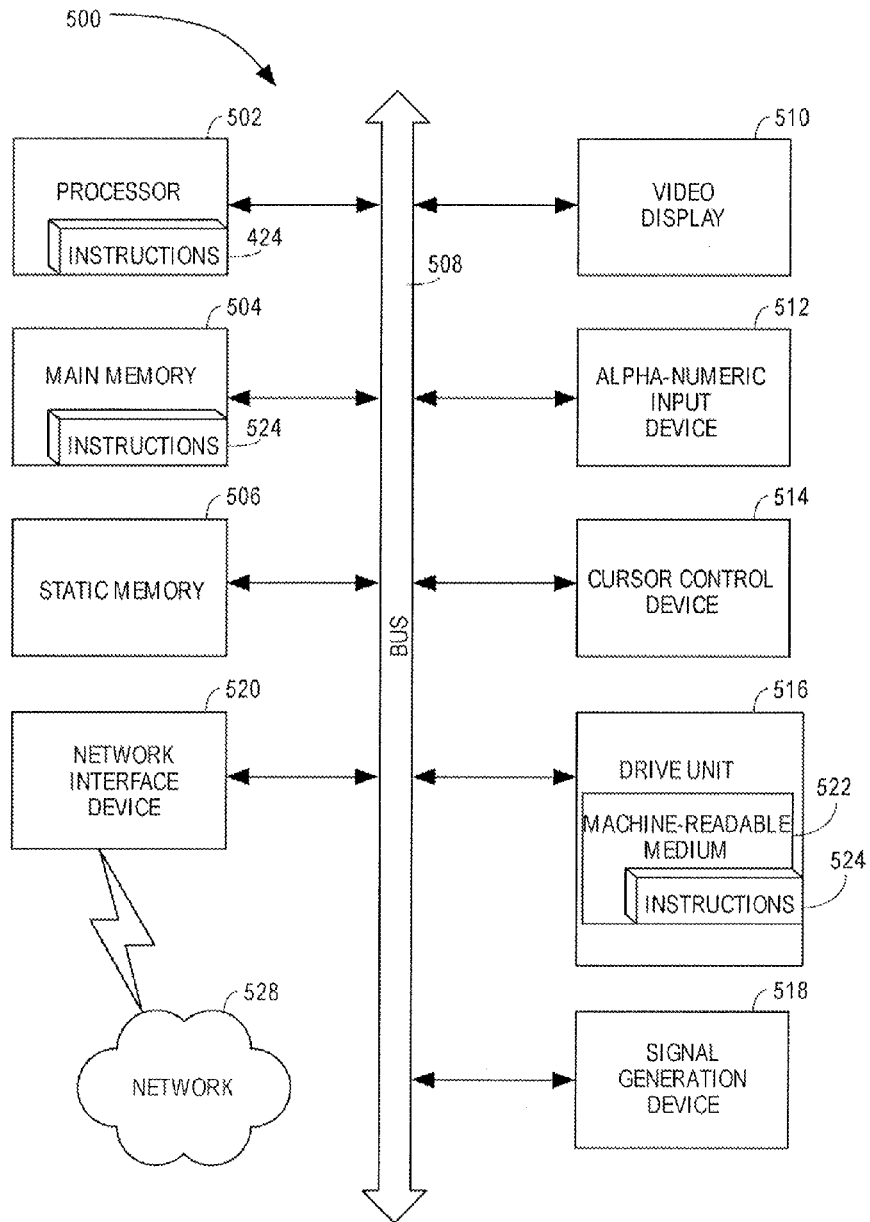

FIG. 5

**SYSTEMS AND METHODS FOR EXECUTING
AN APPLICATION ON A MOBILE DEVICE****BACKGROUND OF THE INVENTION**

[0001] 1. Field of the Invention

[0002] This invention refers to systems and methods for executing an application on a mobile device.

[0003] 2. Discussion of Related Art

[0004] Mobile devices including mobile phones (Cellular, Voice over Internet Protocol), personal digital assistants, and mobile email devices, smart phones, and mobile internet devices are commonly used throughout the world as communication devices. Mobile device users are more frequently using mobile devices for more complex applications, such as internet banking and social networking.

[0005] There are currently a myriad of mobile device platforms or operating systems, some of which include Java 2 Micro Edition (J2ME), Binary Runtime Environment for Wireless (BREW), Windows Mobile, Palm Operating System, Symbian Operating System, Wireless Internet Platform for Interoperability (WIPI), and the BlackBerry Operating System. Each operating system has different requirements for application software, therefore application developers are forced to write several different iterations of one application in order to satisfy the market place. Additionally the processing power and memory of most mobile devices is comparatively weak in terms of the requirements for compiling advanced mobile applications. Currently if an application needs to be installed on a mobile device, the processing power of the mobile device must be consumed in order to compile the application, resulting in a slow loading and slow performance. Furthermore, if an application needs updating, the entire application will need to be reinstalled and compiled, adding more time and complexity to the application.

SUMMARY OF THE INVENTION

[0006] The invention provides a computer implemented method to execute a bytecode by a mobile runtime environment, the method including receiving an uploaded source code at a remote server, compiling the source code into a bytecode on the remote server, sending a first runtime engine to a mobile device, wherein the first runtime engine communicates with an operating system of the mobile device, and sending the bytecode to the mobile device, wherein the bytecode is executable by the first runtime engine on the mobile device.

[0007] The computer implemented method may additionally include updating the bytecode.

[0008] The bytecode may not require user intervention for updating.

[0009] The computer implemented method may additionally include sending a second runtime engine to the second mobile device, wherein the second runtime engine communicates with a second operating system of the second mobile device, and wherein the operating system and second operating system have different application requirements for each respective runtime engine, and sending the bytecode to the second mobile device, wherein the bytecode is executable by the second runtime engine on the mobile device.

[0010] The source code may be at least partially constructed of machine executable code.

[0011] The machine executable code may be ECMAScript.

[0012] The method may additionally include receiving an uploaded image on the remote server, converting and down scaling the image file on the remote server, and sending the converted and down scaled image file to the mobile device. The method may additionally include receiving an uploaded data file on the remote server, converting the data file into a binary format on the remote server, sending the binary format of the data file to the mobile device.

[0013] The method may additionally include receiving an uploaded data file on the remote server, converting the data file into a binary format on the remote server, sending the binary format of the data file to the mobile device.

[0014] The invention also provides a computer implemented method to execute a bytecode by a mobile runtime environment, the method including receiving an uploaded source code at a remote server, compiling the source code into a bytecode on the remote server, sending a plurality of runtime engines to a plurality of mobile devices, wherein each runtime engine communicates with a specific operating system of a mobile device, and wherein each specific operating system has different application requirements, and sending the bytecode to the plurality of mobile devices, wherein the bytecode is executable by each respective runtime engine on each respective mobile device.

[0015] The computer implemented method may additionally include updating each respective bytecode located on each respective mobile device.

[0016] No user intervention may be required for updating each respective bytecode.

[0017] The source code may be at least partially constructed of machine executable code.

[0018] The machine executable code may be ECMAScript.

[0019] The computer implemented method may additionally include receiving an uploaded image at the remote server, converting and down scaling the image file on the remote server, and sending the converted and down scaled image file to the plurality of mobile devices.

[0020] The computer implemented method may additionally include receiving an uploaded data file at the remote server, converting the data file into a binary format on the remote server, and sending the binary format of the data file to the plurality of mobile devices.

[0021] The invention also provides a computer implemented method to execute a bytecode by a mobile runtime environment, the method including storing a bytecode on a remote server, the bytecode previously compiled from a source code, receiving a request for the bytecode from a runtime engine on a mobile device, and sending the bytecode to the mobile device, wherein the bytecode is executable by the runtime engine on the mobile device.

[0022] The computer implemented method may additionally include receiving a second request for updated bytecode from the mobile device, and sending updated bytecode to the mobile device.

[0023] The invention also provides a computer implemented method to execute a bytecode by a mobile device runtime environment, the method including receiving a runtime engine at a mobile device from a remote server, wherein the runtime engine communicates with an operating system of the mobile device, and receiving a bytecode at the mobile device from the remote server, wherein the bytecode was compiled from source code on the remote server, and executing the bytecode by the runtime engine on the mobile device.

[0024] The computer implemented method may additionally include receiving updated bytecode.

[0025] Receiving updated bytecode may not require user intervention.

[0026] The mobile device may be a mobile telephone.

[0027] The computer implemented method may additionally include requesting the remote server for an updated bytecode.

[0028] Requesting the remote server for an updated bytecode may not require user intervention.

[0029] The invention also provides a system for executing a bytecode by a runtime environment, the system including a remote server for uploading a source code and compiling the source code into a bytecode, a mobile device for receiving the bytecode, and a runtime engine on the mobile device for executing the bytecode.

[0030] The system, may additionally include a remote computer system for uploading and hosting the bytecode.

BRIEF DESCRIPTION OF THE DRAWINGS

[0031] The invention is further described by way of example(s) with reference to the accompanying drawings, wherein:

[0032] FIG. 1 is system level flow chart for executing an application on a mobile device.

[0033] FIG. 2 is system level flow chart for transcoding images for an application on a mobile device.

[0034] FIG. 3 is system level flow chart for encoding a data file for an application on a mobile device.

[0035] FIG. 4 is a system level flow chart for executing an application on a mobile device, transcoding images for an application on a mobile device, and encoding a data file for an application on a mobile device.

[0036] FIG. 5 is a block diagram of an exemplary computer system.

DETAILED DESCRIPTION OF THE INVENTION

[0037] FIG. 1 of the accompanying drawings shows a flow chart, according to an embodiment of the invention. FIG. 1 illustrates a source file being compiled into bytecode which is sent to a mobile device. A third party computer or third party sever **100** hosts a source code **102**. The source code **102** is written using an integrated developer environment (IDE), such as the open development platform Eclipse Integrated Development Environment, partially including both machine executable code and markup language, such as Extensible Markup Language (XML), Cascading Style Sheets (CSS), and European Computer Manufacturers Association Script (ECMAScript).

[0038] The source file is a set of instructions intended as an application that operates on a virtual machine, i.e. a runtime engine, on a mobile device. A runtime engine is software that creates a virtual environment, or runtime environment, on an operating system. The advantage to using software intended for a runtime engine, as opposed to writing instructions directly for the operating system, is that one set of software instructions may be implemented on a variety of operating systems.

[0039] There are currently a myriad of operating systems in the mobile world, e.g. BREW, WIP, J2ME, Windows Mobile, etc., which all have very different software requirements for source code. Thus implementing a runtime engine that can operate on a myriad of operating systems allows

software designers to write only one set of source code, rather than a separate source code for each operating system. A separate runtime engine is required for each operating system, however implementation of a separate runtime engine is less costly and time consuming than writing separate source code, because a runtime engine is often created by a different entity and preexists prior to the source code.

[0040] The source file is uploaded to a remote server **104**. At the remote server **104** the source code **102** is compiled once and stored on the server. The source code **102** is compiled into bytecode **108** by a compiler **106** residing on the remote server **104**. Bytecode is a binary representation of executable software designed to be executed by a runtime engine. The runtime engine cannot execute the source code directly, because source code is a representation of instructions that are readable by a human, i.e. one skilled in the art of software programming, and not readable by a runtime engine.

[0041] The source code **102** may be compiled at the request of a runtime on a mobile device. Alternatively, the source code **102** may have been previously compiled and stored on the server. The remote server **104** may also store different runtime engines which are intended for use on different mobile operating systems. The remote server **104** also operates as a communications gateway because it can send the bytecode and runtime engines over a cellular communications network or alternatively to a data network (a private network or the Internet), or combination thereof.

[0042] The bytecode **108** is sent to a mobile device **110**, typically in response to a request from the runtime engine on the mobile device **110**. A runtime engine may first be sent to a mobile device **110**, if the mobile device **100** does not already have the runtime engine residing on it. The bytecode **108** may be stored on the mobile device **110** and used for final execution by the runtime engine on the mobile device **110**.

[0043] The runtime engine has relatively little work to perform executing the bytecode as the compiler **106** on the server has done the majority of the work of parsing and optimizing the source code. This method is particularly advantageous for mobile devices. Mobile device are constrained technologically, because of size and cost considerations, to have relatively weak processing power. Therefore, if the compilation of the source code occurred on the mobile device, the final execution of the source code would require more time and processing power.

[0044] The same bytecode **108** may be sent to a plurality of mobile devices **110** (e.g. a first mobile device, a second mobile device, a third mobile device, etc.) without any alteration to the bytecode, where each mobile device has a different operating system. The ability to upload the same bytecode **108** to a plurality of devices **110** allows for a single uploaded, source code **102** and subsequently compiled bytecode **108** to be used on a myriad of operating systems.

[0045] It is important to note that the methods described herein offer a great advantage in terms of resourcing processing power and compilation time. The source code **102** for an application on a mobile device **110** does not require a great deal of processing power or time on a server, because a mobile device application is rather simplistic compared to a server processing system as opposed to being very demanding to a mobile device **110** processing system. The processing power of the remote server **104** is on several magnitudes greater than the mobile device **110**, thus compiling the source code **102** (of a mobile device application) on a remote server **104** occurs several times more rapidly than compiling on a mobile device

110. Thus, even considering the downloading and receiving of a bytecode over a network to a mobile device **110** and the demands of the remote server **104** to perhaps compile a plurality of application simultaneously, compiling source code **102** into bytecode **108** on a remote server **104** is still much faster than compiling source code **102** on a mobile device **110**.

[0046] The remote server **104** also allows updating the bytecode **108** as needed. Updating may be performed without any user interaction on the mobile device **110**, and thus updating is performed seamlessly and unknowingly to the user. Updating bytecode **108** is particularly advantageous for application which requires frequent updates, because source code compilation is performed on the remote server **104** saving processing time on the mobile device. Updating an application may thus be invisible to the user because the runtime engine would already be installed on a mobile device **110** requiring no new installation time, and the updated bytecode **108** may be downloaded when the application is not in use. For example, when a mobile device **110** logs on to a data network or is alternatively dormant, the runtime engine or application may automatically and periodically check for updates and download updated bytecode **108** as necessary.

File Conversion

[0047] FIG. 2 shows a flow chart which illustrates an image file being converted and down scaled, and sent to a mobile device. In addition to compiling source code into byte code, the server may also convert image files. A third party computer or third party server **200** or hosts image files, such as Joint Photographic Experts Group (JPEG) files and Graphics Interchange Format (GIF) image files **202**. The image files **202** are uploaded to the remote server **204** and converted and scaled as necessary by art image transcoder **206** residing on the remote server **204**. The image transcoder **206** converts large image files into a format compatible with a mobile device. The image transcoder **206** simultaneously converts the image file **202** as the source code **102** is being compiled. The converted image **208** is sent to mobile device **210** on the same data stream as the bytecode **108** for use in the same application.

[0048] FIG. 3 shows a flow chart which illustrates a data file, for example an XML file, being converted a binary data file, for example WAP Binary XML (WBXML) file, and sent to a mobile device. Data files written in markup languages are commonly used for Internet applications. XML is a language which has the purpose of presenting data in a structured manner such that it may be useable between different systems, especially over the Internet. XML files should be understood to be structured data files, and not instructions or machine executable code. Data files **302** are hosted by a third party server or third party computer **300**. A remote server **304** includes an encoder **306** which converts the data file **302** into a binary data file **308**, such as WBXML file. WBXML files are binary representations of XML files and are therefore smaller and more easily transmittable over a mobile network. The encoder **306** residing on the remote server **304** converts the data file **302** while the source code **102** is being compiled. The data file **302** is sent to a mobile device **310** on the same data stream as the bytecode **108** for use in the same application.

[0049] FIG. 4 shows a chart illustrating the integration of the methods shown in FIGS. 1-3. Typically a third party server **400** will host a file **402** which will have a combination

of source code, image files, and data files, depending on the properties of the final application. For example some applications will not require the file **400** to include images. The file **400** is uploaded to a remote server **404** that will in a parallel or operation compile source code, transcode image files, and encode data files. Alternatively the remote server **404** may perform operations in series. The output file **408** containing the bytecode, transcoded image files, and encoded data files will then be sent to a mobile device **410**. The output file **408** is then executed on the mobile device **410** as a useful application.

Exemplary Data Processing System

[0050] FIG. 5 of the accompanying drawings illustrates an exemplary computer system **500**, also known as a data processing system that can for example form the remote server of FIG. 1, 2, or 3. The operations, processes, modules, methods, and systems described and shown in the accompanying figures of this disclosure are intended to operate on one or more exemplary computer systems **500** as sets of instructions (e.g. software), also known as computer implemented methods. The exemplary computer system **500** is generally representative of personal or client computers, mobile devices (e.g. mobile cellular device, PDA, satellite phone, mobile VoIP device), and servers. A mobile device will also have an antenna and a microchip, for running a protocol for the radio frequency reception and transmission of communications signals. The exemplary computer system **500** includes at least one processor **502** (e.g., a Central Processing Unit (CPU), a Graphics Processing Unit (GPU) or both), a main memory **504** (e.g., Read Only Memory (ROM), flash memory, Dynamic Random Access Memory (DRAM) such as Synchronous DRAM (SDRAM) or Rambus DRAM (RDRAM), etc.), and a static memory **506** (e.g., flash memory, Static Random Access Memory (SRAM), etc.), which communicate with each other via a bus **508**.

[0051] The computer system **500** may further include a video display **510** (e.g. Liquid Crystal Display (LCD) or a Cathode Ray Tube (CRT) or a touch screen). The computer system **500** also includes an alphanumeric input device **512** (e.g., a keyboard, phone pad, touch screen), a cursor control device **514** (e.g., a mouse), a disk drive unit **516**, a signal generation device **518** (e.g. a speaker), and a network interface device **520**. The network interface device will at least be wireless in case of a mobile device, for communicating to a wireless network (e.g. cellular, VoIP). If the computer system **500** functions as a server, the video display **510**, input device **512**, signal generation device **518**, and cursor control device **514** may not be needed. A mobile device will include one or more signal input devices (e.g. a microphone, camera, fingerprint scanner) which is not shown.

[0052] The disk drive unit **516** includes a machine-readable medium **522** on which is stored one or more sets of instructions **524** (e.g. software) embodying any one or more methodologies or functions. The software may also reside, completely or at least partially, within the main memory **504** and/or within the processor **502** during execution thereof by the computer system **500**, the main memory **504**, and the processor **502** also constituting machine-readable media.

[0053] The software may further be transmitted or received over a network **528** via the network interface device **520**.

[0054] While the machine-readable medium **524** is shown in an exemplary embodiment to be a single medium, the term "machine-readable medium" should be taken to include a

single medium or multiple media (e.g., a centralized or distributed database, and/or associated caches and servers) that store the one or more sets of instructions. The term “machine-readable medium” shall also be taken to include any medium that is capable of storing, encoding or carrying a set of instructions for execution by the machine and that cause the machine to perform one or more methodologies. It should be known that the processes, methods, and modules disclosed herein are intended to be contained as instructions on a machine readable medium.

[0055] While certain exemplary embodiments have been described and shown in the accompanying drawings, it is to be understood that such embodiments are merely illustrative and not restrictive of the current invention, and that this invention is not restricted to the specific constructions and arrangements shown and described since modifications may occur to those ordinarily skilled in the art.

1.-25. (canceled)

26. A computer implemented method for updating mobile device applications comprising:

providing, by a server computer system, a first application compatible with a first operating system in operation on some of a plurality of mobile devices and a second application compatible with a second operating system in operation on others of the plurality of mobile devices, wherein the first operating system and the second operating system are different; and

providing, by the server computer system to at least one of the mobile devices compatible with the first operating system, an update to the first application while the first application is not in operation, wherein the update comprises a configuration for use with the first application and the second application.

27. The computer implemented method of claim **26** further comprising providing, by the server computer system, the update to the second application while the second application is not in operation.

28. The computer implemented method of claim **26** wherein the update comprises operating system independent byte code.

29. The computer implemented method of claim **28** further comprising compiling source code to generate the operating system independent byte code.

30. The computer implemented method of claim **26** wherein the update comprises data configured for use by the first application or the second application.

31. The computer implemented method of claim **26** wherein the update is provided without user interaction.

32. The computer implemented method of claim **26** wherein the first application is configured to periodically check for the update.

33. The computer implemented method of claim **26** wherein the first application is configured to check for the update when the mobile device to which it was provided logs on to a data network.

34. A system for updating an application to a mobile device, the system comprising:

one or more memory devices storing software instructions; and

one or more processors configured to execute the software instructions to:

provide a first application compatible with a first operating system in operation on some of a plurality of mobile devices and a second application compatible with a second operating system in operation on others of the plurality of mobile devices, wherein the first operating system and the second operating system are different; and

provide, to at least one of the mobile devices compatible with the first operating system, an update to the first application while the first application is not in operation, wherein the update comprises a configuration for use with the first application and the second application

35. The system of claim **34**, wherein the one or more processors are further configured to execute the software instructions to provide the update to the second application while the second application is not in operation.

36. The system of claim **34**, wherein the update comprises operating system independent byte code.

37. The system of claim **36**, wherein the one or more processors are further configured to execute the software instructions to compile source code to generate the operating system independent byte code.

38. The system of claim **34**, wherein the update comprises data configured for use by the first application or the second application.

39. The system of claim **34**, wherein the update is provided without user interaction.

39. The system of claim **34**, wherein the first application is configured to periodically check for the update.

40. The system of claim **34**, wherein the first application is configured to check for the update when the mobile device to which it was provided logs on to a data network.

41. A non-transitory computer readable medium storing instructions that, when executed by one or more processors, causes the one or more processors to perform operations comprising:

providing a first application compatible with a first operating system in operation on some of a plurality of mobile devices and a second application compatible with a second operating system in operation on others of the plurality of mobile devices, wherein the first operating system and the second operating system are different; and

providing, to at least one of the mobile devices compatible with the first operating system, an update to the first application while the first application is not in operation, wherein the update comprises a configuration for use with the first application and the second application.

42. The non-transitory computer readable medium of claim **41** wherein the update comprises operating system independent byte code.

43. The non-transitory computer readable medium of claim **41** wherein the update is provided without user interaction.

44. The non-transitory computer readable medium of claim **41** wherein the first application is configured to periodically check for the update.

45. The non-transitory computer readable medium of claim **41** wherein the first application is configured to check for the update when the mobile device to which it was provided logs on to a data network.

* * * * *