

(19) World Intellectual Property Organization
International Bureau



(43) International Publication Date
18 August 2005 (18.08.2005)

PCT

(10) International Publication Number
WO 2005/075060 A1

(51) International Patent Classification⁷: B01D 59/12,
53/22, 24/00, 39/14

(21) International Application Number:
PCT/US2004/015300

(22) International Filing Date: 14 May 2004 (14.05.2004)

(25) Filing Language: English

(26) Publication Language: English

(30) Priority Data:
10/770,732 2 February 2004 (02.02.2004) US

(71) Applicants and

(72) Inventors: BOSSARD, Peter, R. [US/US]; 105 Railroad Drive, Ivyland, PA 18974 (US). PETKIE, Ronald, R. [US/US]; 304 Surrey Place, Macungie, PA 18062 (US).

(74) Agent: LAMORTE, Eric; LaMorte & Associates, P.C., P.O. Box 434, Yardley, PA 19067 (US).

(81) Designated States (unless otherwise indicated, for every kind of national protection available): AE, AG, AL, AM, AT, AU, AZ, BA, BB, BG, BR, BW, BY, BZ, CA, CH, CN,

CO, CR, CU, CZ, DE, DK, DM, DZ, EC, EE, EG, ES, FI, GB, GD, GE, GH, GM, HR, HU, ID, IL, IN, IS, JP, KE, KG, KP, KR, KZ, LC, LK, LR, LS, LT, LU, LV, MA, MD, MG, MK, MN, MW, MX, MZ, NA, NI, NO, NZ, OM, PG, PH, PL, PT, RO, RU, SC, SD, SE, SG, SK, SL, SY, TJ, TM, TN, TR, TT, TZ, UA, UG, US, UZ, VC, VN, YU, ZA, ZM, ZW.

(84) Designated States (unless otherwise indicated, for every kind of regional protection available): ARIPO (BW, GH, GM, KE, LS, MW, MZ, NA, SD, SL, SZ, TZ, UG, ZM, ZW), Eurasian (AM, AZ, BY, KG, KZ, MD, RU, TJ, TM), European (AT, BE, BG, CH, CY, CZ, DE, DK, EE, ES, FI, FR, GB, GR, HU, IE, IT, LU, MC, NL, PL, PT, RO, SE, SI, SK, TR), OAPI (BF, BJ, CF, CG, CI, CM, GA, GN, GQ, GW, ML, MR, NE, SN, TD, TG).

Declarations under Rule 4.17:

- as to the identity of the inventor (Rule 4.17(i)) for all designations
- as to the identity of the inventor (Rule 4.17(i)) for all designations

Published:

- with international search report

[Continued on next page]

(54) Title: COMPOSITE STRUCTURE FOR HIGH EFFICIENCY HYDROGEN SEPARATION AND ITS ASSOCIATED METHODS OF MANUFACTURE AND USE

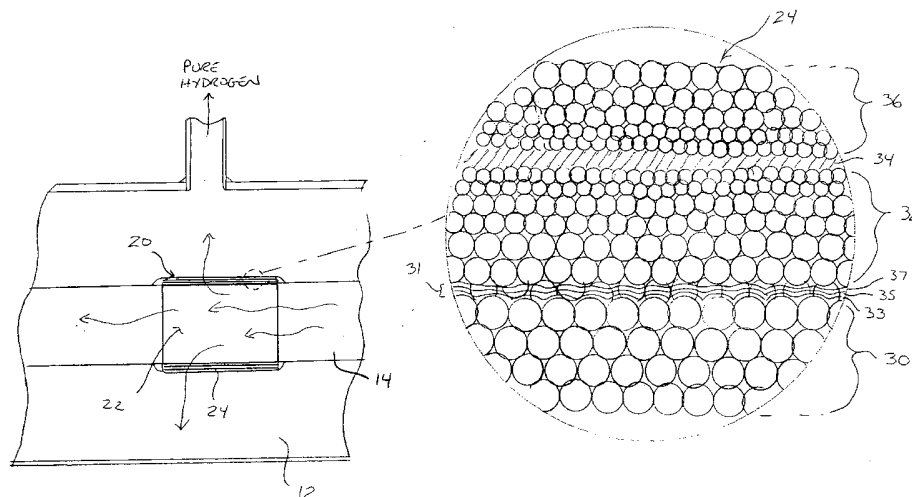

(57) Abstract: A hydrogen purification system and method that utilizes a hydrogen separator with a novel composite structure. The hydrogen separator has a first porous layer of a hydrogen permeable material, such as a palladium alloy. A solid layer of the same hydrogen permeable material is then disposed onto the first porous layer. A pressure differential is created across the structure of the composite hydrogen separator. The porous layer of hydrogen permeable material supports the solid layer and enables the solid layer to withstand large pressure differentials. Furthermore, the porous layer of the hydrogen permeable material bonds to the solid layer, thereby greatly increasing the effective surface area of the solid layer that is exposed to hydrogen gas. Accordingly, a large flow rate of hydrogen gas can be obtained in a small amount of space.

WO 2005/075060 A1



For two-letter codes and other abbreviations, refer to the "Guidance Notes on Codes and Abbreviations" appearing at the beginning of each regular issue of the PCT Gazette.

COMPOSITE STRUCTURE FOR HIGH EFFICIENCY HYDROGEN SEPARATION
AND ITS ASSOCIATED METHODS OF MANUFACTURE AND USE

TECHNICAL FIELD OF THE INVENTION

5 The present invention relates to systems and methods
that are used to separate molecular hydrogen from a volume
of gas. More particularly, the present invention is related
to systems and methods that separate hydrogen from a volume
of mixed gas by exposing the mixed gas to a hydrogen
10 permeable material through which only atomic hydrogen can
readily pass.

BACKGROUND ART

15 In industry there are many applications for the use of
molecular hydrogen. However, in many common processes that
produce hydrogen, the hydrogen gas produced is not pure.
Rather, when hydrogen is produced, the resultant gas is
often contaminated with water vapor, hydrocarbons and/or
other contaminants. In many instances, however, it is
20 desired to have ultra pure hydrogen. In the art, ultra pure
hydrogen is commonly considered to be hydrogen having
purity levels of at least 99.999%. In order to achieve such
purity levels, hydrogen gas must be actively separated from
its contaminants.

In the prior art, one of the most common ways to purify contaminated hydrogen gas is to pass the gas through a conduit made of a hydrogen permeable material, such as palladium or a palladium alloy. As the contaminated

5 hydrogen gas passes through the conduit, atomic hydrogen permeates through the walls of the conduit, thereby separating from the contaminants. In such prior art processes, the conduit is kept internally pressurized and is typically heated to at least three hundred degrees

10 centigrade. Within the conduit, molecular hydrogen disassociates into atomic hydrogen on the surface of the conduit and the conduit absorbs the atomic hydrogen. The atomic hydrogen permeates through the conduit from a high pressure side of the conduit to a low pressure side of the

15 conduit. Once at the low pressure side of the conduit, the atomic hydrogen recombines to form molecular hydrogen. The molecular hydrogen that passes through the walls of the conduit can then be collected for use. Such prior art systems are exemplified by U.S. Patent No. 5,614,001 to

20 Kosaka et al., entitled Hydrogen Separator, Hydrogen Separating Apparatus And Method For Manufacturing Hydrogen Separator.

The flow rate of hydrogen gas through the walls of a

conduit is proportional to the length of the conduit and the thickness of the walls of the conduit. Thus, a highly efficient purification system would have a very long, very thin conduit to maximize flow rate. However, palladium is a very expensive precious metal. Consequently, conduits made of palladium and palladium alloys are very expensive to manufacture. As such, it is desirable to use as little of the palladium as possible in manufacturing a hydrogen gas purification system. Furthermore, conduits made from palladium and palladium alloys typically hold gas under pressure and at high temperatures. Accordingly, the walls of the conduit cannot be made too thin, else the conduit will either rupture or collapse depending on the pressure gradient present across the wall of the conduit.

A typical prior art conduit made from palladium or a palladium alloy would have a wall thickness of approximately 80 μ m. The thickness of the wall of the conduit is inversely proportional to the amount of purified hydrogen that passes through that wall in a given period of time. As such, in order to make the conduit more efficient, a thinner wall is desirable. However, as has already been stated, a conduit wall cannot be made so thin that it ruptures or collapses under the pressure of the gasses

being passed through that conduit.

To further complicate matters, conduits made from palladium and palladium alloys may become less efficient over time as the interior walls of the conduits become
5 clogged with contaminants. In order to elongate the life of such conduits, many manufacturers attempt to clean the conduits by reverse pressurizing the conduits. In such a procedure, the exterior of the conduit is exposed to pressurized hydrogen. The hydrogen passes through the
10 conduit wall and into the interior of the conduit. As the hydrogen passes into the interior of the conduit, the hydrogen may remove some of the contaminants that were deposited on the interior wall of the conduit.

Due to the generally cylindrical shape of most prior
15 art hydrogen purification conduits, the conduits are capable of withstanding a fairly high pressure gradient when the interior of the conduit is pressurized higher than the exterior of the conduit. However, when such conduits are cleaned and the external pressure of the conduit is
20 raised higher than the interior pressure, a much lower pressure gradient must be used, else the conduit will implode.

In the prior art, improved conduit designs have been

developed that attempt to minimize the amount of palladium used in a conduit, yet increase the strength of the conduit. One such prior art device is shown in U.S. Patent No. 4,699,637 to Iniotakis, entitled Hydrogen Permeation
5 Membrane. In the Iniotakis patent, a thin layer of palladium is reinforced between two layers of mesh. The laminar structure is then rolled into a conduit. Such a structure uses less palladium. However, the conduit is incapable of holding the same pressure gradient as solid
10 palladium conduits. Accordingly, the increase in efficiency provided by the thinner palladium layer is partially offset by the decreased pressure limits, and thus gas flow rate, that are capable of being processed.

Another prior art approach to limiting the amount of
15 palladium used is to create membranes that are placed over apertures, like a skin on a drum. A pressure gradient is then created on opposite sides of the membrane, thereby causing hydrogen to flow through the membrane. Such prior art systems are exemplified by U.S. Patent No. 5,734,092 to
20 Wang et al., entitled Planar Palladium Structure. A problem associated with such prior art systems is that the palladium or palladium alloy membrane is typically positioned in a level plane, wherein a pressure gradient

exists from one side of the membrane to the other. Since the membrane is flat, it has little structural integrity when trying to resist the forces created by the pressure gradient. Accordingly, in order to prevent the membrane
5 from rupturing, solid perforated substrates are used to reinforce the membrane. The solid perforated substrates, however, are complicated to manufacture, restrict the flow through the membrane, and reduce the efficiency of the overall system.

10 U.S. Patent No. 6,152,987 to Ma, entitled Hydrogen Gas-Extraction Module And Method Of Fabrication, discloses a hydrogen separator where a solid layer of hydrogen permeable material is deposited over a porous substrate of dissimilar material. The porous substrate supports the
15 hydrogen permeable material and provides much more support than prior art mesh support systems. However, the porous substrate only allows gas to contact the hydrogen permeable material where a pore gap is exposed to the hydrogen permeable material. This configuration greatly limits the
20 area of hydrogen permeable material actually exposed to gas. Furthermore, due to differences thermal coefficients and other physical properties, hydrogen permeable material deposited on a substrate of a dissimilar material tends to

separate from the substrate. This can cause leakage of contaminated gas through the hydrogen permeable material and the eventual failure of system.

U.S. Patent Application No. 2003/0190486 to Roa et al,
5 also discloses a hydrogen separator where a solid layer of hydrogen permeable material is deposited over a porous substrate of dissimilar material. In the Roa application, a palladium alloy is deposited over the porous substrate of dissimilar material using first electroplating process.
10 Copper is then deposited on the palladium in a second electroplating process. The palladium and copper layers are then annealed to produce a palladium alloy in place on the substrate. However, the porous substrate only allows gas to contact the hydrogen permeable material where a pore gap is
15 exposed to the hydrogen permeable material. This configuration greatly limits the area of hydrogen permeable material actually exposed to gas.

Furthermore, palladium alloy does not bond well to the porous substrate of dissimilar material. This leads to
20 eventual failure.

In prior art systems such as the Ma patent and the Roa application, where palladium alloy is deposited directly on a porous substrate, another problem is that the substrates

have large pore sizes to maximize exposure of the palladium alloy to gas. This requires that thick uneven layers of palladium be deposited over the porous substrate to cover the pores of the substrate. This causes faults in the layer
5 of palladium that tend to fail over time.

A need therefore exists in the art of hydrogen purification for a system and method that can handle high flow rates of gas, per unit area, and yet uses only a minimal amount of hydrogen permeable material. A need also
10 exists for a hydrogen purification system with a hydrogen permeable layer that is strongly bonded to its supporting substrate so that it can more reliably withstand large pressure gradients and repeated temperature cycles over longer periods of time. These needs are met by the present
15 invention as described and claimed below.

DISCLOSURE OF THE INVENTION

The present invention is a hydrogen purification
20 system and method that utilizes a novel composite hydrogen separator. The composite hydrogen separator has a first porous layer of a hydrogen permeable material, such as a palladium alloy. A solid layer of the same hydrogen

permeable material is then disposed onto the first porous layer. A pressure differential is created across the structure of the composite hydrogen separator. The porous layer of hydrogen permeable material supports the solid
5 layer and enables the solid layer to withstand large pressure differentials. Furthermore, the porous layer of the hydrogen permeable material is diffusion bonded to the solid layer, thereby greatly increasing the effective surface area of the solid layer that is exposed to hydrogen
10 gas. Accordingly, a large flow rate of hydrogen gas can be obtained in a small amount of space.

The hydrogen permeable material can be further supported by a porous metallic structure that adds structural integrity to the composite hydrogen separator
15 and prevents the composite hydrogen separator from deforming when exposed to very large pressure gradients.

The result is a hydrogen purification system that is small and uses limited amounts of precious metals, yet has a high hydrogen gas flow rate.

20

BRIEF DESCRIPTION OF THE DRAWINGS

For a better understanding of the present invention, reference is made to the following description of exemplary

embodiments thereof, considered in conjunction with the accompanying drawings, in which:

FIG. 1 is a schematic of an exemplary embodiment of a
5 hydrogen purification system;

FIG. 2 is a fragmented view of an exemplary embodiment of a composite hydrogen separator with a cross-sectional enlargement;

10

FIG. 3 is a cross-sectional view of the base layer used in an exemplary embodiment of the present invention;

FIG. 4 is a schematic of a manufacturing step used in
15 production of an exemplary embodiment of the present invention;

FIG. 5 is a schematic of a manufacturing step used in production of an exemplary embodiment of the present
20 invention;

FIG. 6 is a schematic of a manufacturing step used in production of an exemplary embodiment of the present

invention;

FIG. 7 is a schematic of a manufacturing step used in
production of an exemplary embodiment of the present
5 invention;

FIG. 8 is a schematic of a manufacturing step used in
production of an exemplary embodiment of the present
invention;

10

FIG. 9 is a schematic of an alternate manufacturing
process used in production of an alternate exemplary
embodiment of the present invention;

15 FIG. 10 is a cross-sectional view of an alternate
embodiment of a composite hydrogen separator;

FIG. 11 is a schematic of a second exemplary
manufacturing process used to form the composite hydrogen
20 separator of the present invention; and

FIG. 12 is a schematic of a third exemplary
manufacturing process used to form the composite hydrogen

separator of the present invention.

BEST MODE FOR CARRYING OUT THE INVENTION

5 The present invention system provides a means for purifying a hydrogen gas at a high flow rate, using a small amount of space and a small amount of precious metals.

 Referring to Fig. 1, there is shown a schematic of an exemplary embodiment of a hydrogen purification system 10
10 in accordance with the present invention. The hydrogen purification system 10 contains a collection chamber 12 for collecting purified hydrogen gas. At least one supply conduit 14 extends into the collection chamber 12 where each of the supply conduits 14 is coupled to a source of
15 contaminated hydrogen gas 16. The supply conduit 14 is mostly fabricated from stainless steel or an equivalent alloy that is capable of retaining the contaminated hydrogen gas at a first pressure and at a predetermined operating temperature of at least three hundred degrees
20 centigrade.

 Along the supply conduit 14 is disposed a composite hydrogen separator 20. The composite hydrogen separator 20 enables only pure hydrogen gas to permeate out of the

supply conduit 14 and into the collection chamber 12. Once, the purified hydrogen enters the collection chamber 12 it is collected for use.

5 The composite hydrogen separator 20 is the only part of the purification system 10 that is permeable to hydrogen gas. As such, the flow capacity of the overall purification system 10 relies completely upon the flow capacity characteristics of the composite hydrogen separator 20.

10 Referring to Fig. 2, it can be seen that the example of the composite hydrogen separator 20 that is illustrated is tubular in shape, wherein it defines an open central conduit 22. The composite hydrogen separator 20 is attached to the supply conduit 14. Contaminated hydrogen gas under pressure is passed through the central conduit 22 in the center of the composite hydrogen separator 20. The pressure in the surrounding collection chamber 12 is kept lower than the pressure within the central conduit 22. As such, a pressure differential exists across the wall 24 of the composite hydrogen separator 20 that causes hydrogen gas to permeate through the structure of the composite hydrogen separator 20. The greater the pressure differential between the conduit 22 in the composite hydrogen separator 20 and the collection chamber 12, the greater the rate of flow of

15
20

hydrogen out of the composite hydrogen separator 20.

The direction of the flow can be controlled by selectively changing the direction of the pressure differential between the collection chamber 12 and the
5 conduit 22 within the composite hydrogen separator 20. Under normal operating conditions, the pressure within the composite hydrogen separator 20 is kept greater than the pressure within the collection chamber 12. As such,
10 hydrogen gas flows out of the composite hydrogen separator 20 and is purified. However, during maintenance cycles, the pressure of hydrogen gas within the collection chamber 12 can be made greater than the pressure of hydrogen within the composite hydrogen separator 20. In this circumstance,
15 the hydrogen gas flows from the collection chamber 12 into the composite hydrogen separator 20 and can be used to remove contaminants that may have collected on the interior surfaces of the wall 24 of the composite hydrogen separator 20.

The wall 24 of the composite hydrogen separator 20 has
20 a composite structure that is made using a unique combination of formation processes and techniques. From the enlarged segment of Fig. 2, it can be seen that the composition of the wall 24 of the composite hydrogen

separator 20 changes across the thickness of the wall 24. As such, the wall 24 is a composite structure of different materials.

The first layer of the wall is the supporting base layer 30. The base layer 30 is made of a non-reactive metal or metal alloy that in itself is not hydrogen permeable. In a preferred embodiment, the material selected from the base layer is tungsten or molybdenum. However, the base layer 30 of the wall 24 is porous and allows hydrogen gas to freely pass through the pores of its structure. As will later be explained in more detail, the base layer 30 is made using traditional powder metallurgy techniques, where a powder of the non-reactive metal or alloy is formed into the desired shape and sintered into a porous form. Preferably, the base layer 30 is manufactured so that it has pore size of approximately 0.7 μ m prior to sintering. However, larger and smaller pore ~~particle~~ sizes can be used.

To promote strong bonding to the porous base layer 30, bonding layers 31 are deposited onto the base layer 30. The bonding layers 31 are thin so that they do not close the pores in the base layer 30. The bonding layers are preferably comprised of three separate layer. The first bonding layer 33 is chromium. The chromium layer is

deposited directly onto the tungsten of the base layer 30. The first bonding layer 33 of chromium bonds with the tungsten of the base layer 30, as will later be explained.

The second bonding layer 35 is a layer of tungsten.

5 The tungsten is deposited over the first bonding layer 33 of chromium and bonds to the chromium.

The third bonding layer 37 is a layer of copper or silver, depending upon the palladium alloy to be used in the hydrogen separator 20. If a palladium-silver alloy is
10 used, silver is used as the third bonding layer 37.

However, it is preferred that a palladium-copper alloy be used. As such, copper is preferably used as the third bonding layer 37. The silver or copper acts as a wetting layer in that it covers ~~flows over~~ the second bonding layer
15 35 of tungsten and provides a surface onto which a palladium alloy can directly diffusion bond.

A first porous layer 32 of hydrogen permeable material is then formed upon the bonding layers 31. The first porous hydrogen permeable layer 32 is preferably made from a
20 palladium alloy, such as $Pd_{1-x}Ag_x$ or $Pd_{1-x}Cu_x$. However, other known hydrogen permeable alloys can also be used. Such alloys include, but are not limited to PdRu, PdAu, PdNi, and PdFe. The first porous layer 32 can be made from

particles of a single size. However, in a preferred embodiment, the size of the palladium alloy particles in the first porous layer are graduated. The palladium alloy particles become smaller the further those particles are
5 from the bonding layers 31 and the base layer 30. The first porous hydrogen permeable layer 32 can be formed in different ways, as will be later described.

A solid layer 34 of palladium alloy or other hydrogen permeable material is deposited over the first porous
10 hydrogen permeable layer 32 using one of the techniques later described. The hydrogen permeable material selected for the solid layer 34 is preferably the same material selected for the first porous hydrogen permeable layer 32. In this manner, the solid layer 34 and the first porous
15 hydrogen permeable layer 32 share physical characteristics, such as thermal expansion. Furthermore, by using the same hydrogen permeable material, the solid layer 24 of hydrogen permeable material can be diffusion bonded to the first porous hydrogen permeable layer 32.

20 The deposited solid layer 34 of hydrogen permeable material is preferably between 0.05 microns and 0.20 microns thick. The deposited solid layer 34 diffusion bonds with the first porous hydrogen permeable layer 32. However,

the deposited solid layer 34 seals the pores of the first porous hydrogen permeable layer 32. As such, any hydrogen gas traveling through the wall 24 of the composite hydrogen separator 20 must permeate through the deposited solid
5 layer 34 in order to advance.

Above the deposited solid layer 34 of hydrogen permeable material is a second porous hydrogen permeable layer 36. The second porous hydrogen permeable layer 36 is also made of the same hydrogen permeable material as the
10 solid layer 34. However, the second porous hydrogen permeable layer 36 is manufactured to be porous. As such, the deposited solid layer 34 of hydrogen permeable material is interposed in between two porous layers 32, 36 of hydrogen permeable material.

15 The base layer 30 of non-reactive metal at the bottom of the wall 24 provides the wall 24 of the composite hydrogen separator 20 with physical strength. This base layer 30 prevents the composite hydrogen separator 20 from being easily inwardly crushed or outwardly expanded.

20 Accordingly, the composite hydrogen separator 20 can withstand large pressure differentials without inwardly or outwardly deforming.

The first porous hydrogen permeable layer 32 and the

second porous hydrogen permeable layer 36 serve two purposes. First, these layers physically support the deposited solid layer 34 of hydrogen permeable material on either side of the solid layer 34. Accordingly, the solid layer 34 of hydrogen permeable material is fully supported at nearly all points along its surface. However, although most all points of the solid layer 34 are supported, the entire solid layer 34 remains active in the permeation of hydrogen gas because the supporting porous layers 32, 36 are also completely permeable to hydrogen gas. The solid layer 34 of hydrogen permeable material can therefore withstand very large pressure differentials between the sides of the solid layer 34 without rupturing.

The first porous hydrogen permeable layer 32 and the second porous hydrogen permeable layer 36 do not obstruct the surface area of the solid layer 34 that is exposed to hydrogen gas. In fact, these porous layers 32, 36 actually increase the effective surface area of the solid layer 34. The first porous hydrogen permeable layer 32 and the second porous hydrogen permeable layer 36 are preferable made of the same material as the deposited solid layer 34. The contact of the first porous hydrogen permeable layer 32 and the second porous hydrogen permeable layer 36 against the

solid layer 34 therefore has the same effect as manufacturing the solid layer 34 with highly textured surfaces. This greatly increases the effective surface area that is exposed to hydrogen gas trying to permeate through the solid layer 34.

Thus, in operation, contaminated gas enters the conduit 22 in the center of the composite hydrogen separator 20. The contaminated gas passes through the pores in the base layer 30 of the wall 24. The contaminated gas also passes through the pores in the first porous hydrogen permeable layer 32 until it contacts the deposited solid layer 34. The deposited solid layer 34 blocks all gasses except hydrogen. The hydrogen permeates through the solid layer 34 where the hydrogen gas directly contacts the solid layer 34. However, the hydrogen gas can also permeate into the areas of the first porous hydrogen permeable layer 32 that are contacting and supporting the deposited solid layer 34. As a result, a very large surface area is available through which hydrogen gas can pass.

Once the hydrogen gas permeates across the deposited solid layer 34, it enters the second porous hydrogen permeable layer 36. The second porous hydrogen permeable layer 36 provides very little resistance to the further

passage of the now purified hydrogen gas into the surrounding collection chamber 12.

When the composite hydrogen separator 20 is being cleaned, pressure differentials are reversed. The second porous hydrogen permeable layer 36 then acts to increase the effective surface area of the deposited solid layer 34 as hydrogen gas flows into the composite hydrogen separator 20 toward the central conduit 22.

10

EXAMPLE OF A MICROSTRUCTURE COMPOSITION FOR A HYDROGEN SEPARATION MEMBRANE

15

As has been previously mentioned, various layers of the wall 24 of the composite hydrogen separator 20 can be made in different ways. Referring to Fig. 3, it will be understood that the base layer 30 is preferably a sintered metal that is sintered into a porous form having a pore ~~pore~~ size of approximately 0.5 μm to 0.9 μm . An average pore size of 0.7 μm microns being preferred and used by way of example. Because of the overall process flexibility and geometric scaling, there is a considerable variation in possible average pore diameter. The base layer 30 can be sintered in the desired form 41 or a sintered block can be machined into the desired base form 41. In the shown

20

example, the desired base form 41 is a tubular section.

Referring to Fig. 4, it can be seen that individual bonding layers 33, 35, 37 are preferably deposited onto the base layer 30 using biased substrate sputtering, where the base layer 30 is the substrate. The base form 41 is placed in a vacuum deposition chamber, wherein each of the individual bonding layers 33, 35, 37 are deposited separately. In a preferred embodiment for this specific pore size of 0.7 micron, the first bonding layer 33 of chromium is deposited in a layer of 0.03 microns. This initial sputtered Chromium layer promotes adhesion. The second bonding layer 35 of tungsten is deposited in a layer of 0.10 microns. The second bonding layer 35 of sputtered tungsten is for a diffusion barrier between the first bonding layer 33 and the subsequent third bonding layer 37. The third bonding layer 37 of copper is deposited in a layer of 0.20 microns. The third bonding layer 37 of copper is for diffusion bonded to the porous layers that follow the sputtering process. The thickness of these three initial bonding layers 33, 35, 37 can be adjusted in accordance with the pore size of layer 30. For the case of an average pore size of 0.7 μm , the thickness of the three bonding layers 33, 35, 37 is preferably what is stated in

the example.

With the preferred thickness of the individual bonding layers 33, 35, 37 stated, the combined bonding layers 31 will have a combined thickness of 0.33 microns. The base layer 30 preferably has a pore size of 0.7 microns. As the individual bonding layers 33, 35, 37 are deposited, the pore size present on the exterior of the assembly becomes smaller. The deposition of thin film material onto facing pore surfaces, obtained through substrate biasing, is controlled in a manner consistent with the specific to the vacuum system geometry, power distribution, and operating parameters during plasma sputtering. In the case of the example, the 0.7 micron pores will be reduced in correspondence to the bonding layer thickness of 0.33 microns; the resulting new pore size will be 0.36 microns, or approximately a 50% reduction in diameter. However, the pores do remain open after the combined bonding layers 31 are applied.

From the above discussion, the flexibility in the process can be seen as a direct correspondence between the initial pore size of base layer 30 and the total thickness of the deposited bonding layers 33, 35, 37. Specifically, the larger the initial pore size in the base layer 30, the

thicker the layer of deposited bonding layers 33, 35, 37, since the pore size can be controlled by the thickness of the bonding layers 33, 35, 37. The thickness of the bonding layers 33, 35, 37 may be approximately proportional to the
5 original thickness stated above for the case of pore size in base layer 30 of 0.7 microns.

It will be understood that the material of described for the bonding layers 33, 35, 37 are exemplary and can be changed. For instance, the first two bonding layers 33, 35
10 can be made from material that is not hydrogen permeable. The third bonding layer 37 can be made permeable to hydrogen and alloy-forming with subsequent layers for diffusion bonding

Referring to Fig. 5, it can be seen that the first
15 porous hydrogen permeable layer 32 is deposited over the bonding layers 33, 35, 37. This can be accomplished in a variety of ways. In the shown manufacturing method, particles of palladium and copper are suspended in a rheological vehicle, such as Hereaus-Cermalloy V633 or
20 V636. Such rheological vehicles are thixotropic agents which are commonly used in nitrogen fireable thick film paste formulations. This suspension forms a thick film paste 43. Using traditional thick film deposition

techniques, such as spin coating, spraying, or screen printing, the thick film paste 43 is deposited over the bonding layers 31, creating a wet four layered slug 45. The particles of palladium and copper in the thick film paste 5 43 are larger than the pores within the exterior of the bonding layers 31. In this manner, the particles of palladium and copper in the thick film paste 43 will not clog the existing pores.

After the layer of thick film paste 43 is applied, the 10 wet slug 45 is dried and fired (sintered) at elevated temperatures into a first thick film layer 47. The drying step is typically performed at 150 °C for 10 minutes to drive off the thinning constituents of the paste. The sintering step is performed at a temperature that is 15 determined by the physical properties of the constituent particles in the thick film paste 43 in order to result in an alloy. In this case, the sintering can be performed at a temperature of 600°C for several hours in an ambient containing several percent of hydrogen. Within the first 20 thick film layer 47, the sintering induces diffusion bonding between the palladium and the copper particles, producing a palladium alloy. The sintering also induces diffusion bonding between the bonding layers 31, the base

layer 30 with the bonding layers 31, and the bonding layers 31 with the first thick film layer 47. This first thick film layer 47 is then bonded cohesively (sintered) and adhesively to the base layer 30 through bonding layers 31.

5 After annealing, a five layered slug 49 is created having a porous base layer 30, three bonding layers 31 and the first thick film layer 47 that are all diffusion bonded together.

 Referring to Fig. 6, it can be seen that subsequent
10 thick film layers can be deposited over the first thick film layer 47, thereby growing the thickness of that layer. The five layered slug 49 is repeatedly subjected to thick film deposition and sintering. Each time a subsequent thick film layer is deposited, the size of the particles used in
15 the thick film paste are decreased, thereby also decreasing the average pore between the particles. The subsequent layers of thick film are sintered and the process is repeated until a first porous hydrogen permeable layer 32
is produced. Hence, the first porous hydrogen permeable
20 layer 32 is comprised of a number of sintered particle sub-layers, where the pore size of each subsequent sub-layer is decreased with respect to the prior layer, progressively decreasing until the final sub-layer has a pore size that

reaches a designed value.

The designed value of the pore size of the final sub-layer is in accordance with the thickness of the solid palladium layer that will be used. As such, the

5 microstructure of permeable layer 32 as a whole possesses the mechanical strength required to withstand the range of differential pressures across a solid palladium layer while in operation. That is, for small values of differential pressure, a solid palladium layer can be relatively thin,

10 hence the final porous layer should possess a relatively small average pore in order for the deposition of a solid palladium layer to close the pores. Similarly, for operating with higher differential pressures, a thicker solid palladium layer may be required for mechanical

15 strength, which therefore requires a thicker solid film and a larger pore size can be used. The design of the microstructure accounts for the practical range of operation of a solid palladium layer, while maximizing the permeance of the solid palladium layer by maintaining a

20 minimum thickness of a solid palladium layer for the required mechanical strength. The design is therefore scalable in accordance with the pressure differential required for mechanical strength.

The sub-layers produce a first porous hydrogen permeable layer 32 has a final thickness T_1 , which is the sum of the annealed thicknesses of all the thick film sub-layers that have been deposited. The first porous hydrogen permeable layer 32 is comprised of a single palladium alloy. However, the particle size and the pore size within the first porous hydrogen permeable layer 32 decreases as a function of distance from the base layer 30. In the outer most application of thick film, it is preferred that the pore size after annealing be between 0.03 microns and 0.05 microns. This pore size produces a relatively smooth surface upon which a solid layer of material can later be deposited.

Referring to Fig. 7, it can be seen that a solid layer 34 of palladium alloy is deposited over the first porous hydrogen permeable layer 32. Many deposition techniques can be used, such as vapor deposition, sputter deposition, spraying, spin coating, dipping or electroplating, or electroless plating. The minimum thickness of the solid layer 34 of palladium alloy is such that the pores are essentially closed after the deposition of the solid layer 34. For bias sputtering, the thickness of the solid layer 34 can be about one-half the average pore size diameter of

first porous hydrogen permeable layer 32 under the appropriate sputtering conditions. However, it is preferred that the thickness of the solid layer 34 of palladium be at least as thick as the pore size existing on the exterior of the first porous hydrogen layer 32 in order to compensate for the deviation in the actual pore. The solid layer 34 of palladium alloy seals the pores of the first porous hydrogen permeable layer 32, thereby preventing any contaminant gas from flowing through the wall structure of the hydrogen separator.

Since the size of the particles used in the first porous hydrogen permeable layer 32 are smallest at its exterior, the surface on which the solid layer 34 is deposited is very even and smooth. The solid layer 34 of palladium covering this smooth layer can therefore be applied in an even layer with relatively small variations and imperfections.

Referring to Fig. 8, it can be seen that after the solid layer 34 of palladium alloy is deposited, at least one thick film layer of palladium and copper particles are deposited onto the solid layer 34 of palladium alloy. After annealing, this produces a second porous hydrogen permeable layer 36 that covers the solid layer 34 of palladium alloy.

The particle size within the second porous hydrogen permeable layer 36 can also be graduated by depositing multiple thick film layers onto the solid layer 34 of palladium alloy. However, the size of the pores in the
5 second porous hydrogen permeable layer 36 that lay against the solid layer 34 of palladium alloy are preferably the same as the pore size in the first porous hydrogen permeable layer 32 immediately adjacent the solid layer 34 of palladium alloy.

10 The contact of the first porous hydrogen permeable layer 32 and the second porous hydrogen permeable layer 36 with the solid layer 34 of palladium alloy increases the effective surface area of the solid layer 34 that is exposed to hydrogen gas diffusion. The purpose of this
15 increase can be explained by considering the following example. Suppose that the powder particle size of the hydrogen permeable material in both the first porous hydrogen permeable layer 32 and the second porous hydrogen permeable layer 36 has an average diameter d on the
20 surfaces that contact the solid layer 34 of palladium alloy. In an ideal simple cubic lattice of connected particles, the surface area occupied by each powdered particle would be d^2 . The pore area created by the contact

between particles in each layer is $d^2(1-\pi/4)$. Furthermore, the exposed area of each hemisphere of a particle is $d^2(\pi/2)$. The sum of these areas is $d^2(1+\pi/4)$, which equals $1.79d^2$. Consequently, the net effect of interposing the
5 deposited solid layer 34 of hydrogen permeable material between porous layers 32, 36 is to increase the effective surface area of the deposited solid layer 34 by seventy-nine percent (79%).

The solid layer 34 of hydrogen permeable material
10 therefore has its surface areas effectively increased by approximately 79% by having the solid layer 34 supported by porous layers 32, 36 of the same hydrogen permeable material.

In Fig. 3 through Fig. 8, the porous layers 32, 36 of
15 hydrogen permeable material were described as being deposited as thick film layers using traditional thick film deposition techniques. Such techniques are preferred if the first and/or second porous layers of hydrogen permeable material are to have graduated particle and pore sizes.
20 However, the first and/or second porous layers of hydrogen permeable material can be manufactured with one consistent particle size and pore size. In such a construction other manufacturing techniques are available.

Referring to Fig. 9, such an exemplary method of manufacture is illustrated. In Fig. 9, the material 40, such as tungsten, that is not hydrogen permeable is provided in powdered form having a known powder particle size. The powdered metal is processed in a first powder metallurgy process 42, where the powder is compressed into a desired form and sintered. The result is a base layer slug 44 having a porous wall.

Bonding layers are then applied to the base layer slug 44 using a repeated sputter deposition process 53. The bonding layers are preferably chromium, tungsten and copper, as has previously been described. This creates a four layer slug 55.

The four layer slug 55 is then sent into a second powder metallurgy process 46. In this second process, powdered hydrogen permeable material is compressed around the four layer slug 55 and is sintered. This creates a five layer slug 48.

The five layer slug 48 is then taken into a deposition process 50, where a solid layer of hydrogen permeable material is deposited around the five layer slug 48, therein creating a six layer slug 52. The deposition process 50 can be any known process by which a thin solid

layer of hydrogen permeable material can be deposited onto the five layer slug 48 so as to coat the five layer slug 48.

5 The six layer slug 52 is then subjected to a third powder metallurgy process 54 where another layer of powdered hydrogen permeable material is compressed around the six layer slug 52 and sintered. The result is a complete seven layered composite hydrogen separator 59.

10 In the manufacturing technique depicted in Fig. 9, powdered material is compacted and sintered to form the porous layers of hydrogen permeable material. The powdered material need not be homogenous metal dust. Rather, it is possible to provide inert ceramic nano-particles and coat those ceramic nano-particles with palladium alloy or some
15 other hydrogen permeable material. The coated ceramic nano-particles can then be compacted and sintered as though they were homogenous metal powder. The advantages of using coated ceramic nano-particles is that the particle size of the powder can be kept much more consistent than can solid
20 metal powder. Thus, a more consistent pore size can be created in the porous layers.

In the embodiments of the composite hydrogen separator thus illustrated and described, a single solid layer is

used. The solid layer is surrounded by a layer of hydrogen permeable material that forms the exterior of the hydrogen separator. Such configurations are merely exemplary and it should be understood that layers within the hydrogen
5 separator can be repeated or eliminated. A composite hydrogen separator with several layers is therefore possible with multiple deposited solid layers disposed between porous layers.

In Fig. 10, an alternate embodiment for the wall 60
10 of a composite hydrogen separator is shown. In this embodiment, the composite wall 60 of the hydrogen separator only has six layers. The six layers are a base layer 62, the three bonding layers 63, a first hydrogen permeable layer 64 and a deposited solid layer 66. The base layer 62,
15 the bonding layers 63 and the first porous hydrogen permeable layer 64 are the same as those previously described. However, the deposited solid layer 66 is now the outermost layer. To increase the surface area of the exterior of the deposited solid layer 66, the exterior of
20 the deposited solid layer 66 is contoured. The contouring can be created by masking sections of the solid layer 66 during deposition or etching the solid layer 66 after deposition. The contouring of the exterior of the deposited

solid layer 66 serves to increase the exterior surface area of the solid layer 66, thereby serving the same function as the second hydrogen permeable layer used in previous embodiments. However, it can be seen that the embodiment of
5 Fig. 10 uses less palladium alloy than the previous embodiments, and is thus less expensive.

Referring to Fig. 11, yet another alternate embodiment for the wall 70 of the present invention composite hydrogen separator is shown. In this embodiment, the composite wall
10 70 of the hydrogen separator again has six layers. The six layers are a base layer 72, the three bonding layers 73, a porous hydrogen permeable layer 74 and a deposited solid layer 76. The base layer 72 can be made using the sintered powder techniques previously described. The bonding layers
15 73 are then deposited on the base layer 72. On top of the bonding layers 73 is deposited a layer of hydrogen permeable material. The layer is initially deposited as a solid layer. The layer is then perforated using traditional masking and etching techniques, thereby creating the porous
20 hydrogen permeable layer 74 that is shown. Since the porous hydrogen permeable layer 74 is created using masking and etching techniques, the size of the holes created in the porous hydrogen permeable layer 74 can be precisely

controlled.

A solid layer 76 of hydrogen permeable material is then deposited over the porous layer 74. The top of the solid layer 76 is then partially etched to increase the surface area of the solid layer 76 exposed to the surrounding atmosphere. The etching can be accomplished either through chemical etching or laser etching.

In the embodiments of the present invention, the hydrogen separator has been described in the form of a tubular conduit. It will be understood that such an embodiment is merely exemplary. The present invention hydrogen separator can be created in any shape, provided the hydrogen separator acts as a barrier between an area of contaminated hydrogen gas and an area of purified hydrogen gas.

Referring to Fig. 12, a construction of a hydrogen separator 80 is shown that is not tubular in shape and using no powdered metallurgical techniques in its construction. In the embodiment of Fig. 12, a base substrate 82 is provided. The base substrate is made of material that is not permeable to hydrogen and can be either a metal alloy or a semiconductor. The base substrate 82, however, is made porous by chemically etching or laser

etching. Bonding layers 83 are deposited on the base substrate 82. A first layer of hydrogen permeable material 84 is applied to the bonding layers 83 using tradition deposition techniques. The first layer of hydrogen
5 permeable material 84 is then perforated by chemical etching or laser etching. The size of the perforations in the base substrate 82 and the size of the perforations in the first layer of hydrogen permeable material 84 are preferably made to be comparable to maintain a constant
10 porosity throughout the two layers.

A second layer of hydrogen permeable material 86 is then deposited over first layer of hydrogen permeable material 84. The second layer of hydrogen permeable material 86 can be partially etched to increase the surface
15 area on exposed on its top. However, the etching of the second layer of hydrogen permeable material 86 is only partial and the second later of hydrogen permeable material 86 remains as a solid barrier over the first porous layer of hydrogen permeable material 84.

20 It will be understood that the embodiments of the present invention system and method that are described and illustrated herein are merely exemplary and a person skilled in the art can make many variations to the

embodiment shown without departing from the scope of the present invention. All such variations, modifications and alternate embodiments are intended to be included within the scope of the present invention as defined by the

5 appended claims.

CLAIMS

1. A hydrogen gas separator, comprising:
a first porous layer made from a hydrogen permeable material; and
a solid layer of said hydrogen permeable material disposed on said first porous layer and in contact with said first porous layer.
2. The separator according to Claim 1, further including a porous base layer for supporting said first porous layer.
3. The separator according to Claim 1, wherein said hydrogen permeable material of said first porous layer and said hydrogen permeable material of said solid base layer are the same material.
4. The separator according to Claim 2, wherein said porous base layer is not comprised of hydrogen permeable material.
5. The separator according to Claim 1, wherein said first porous layer has a pore size that varies as a function of distance from said solid layer.
6. The separator according to Claim 4, further including at least one bonding layer disposed between said porous base

layer and said first porous layer.

7. The separator according to Claim 1, further including a second porous layer made of said hydrogen permeable material, wherein said solid layer of said hydrogen permeable material is interposed between said first porous layer and said second porous layer.

8. The separator according to Claim 2, wherein said porous base layer is a sintered powder having a predetermined average particle size.

9. The separator according to Claim 8, wherein said first porous layer is comprised of multiple thick film layers, wherein each of said thick film layers has a different average particle size of said hydrogen permeable material.

10. The separator according to Claim 1, wherein said solid layer of said hydrogen permeable material is a deposition layer that is deposited onto said first porous layer.

11. The separator according to Claim 2, wherein said porous base layer is shaped as a tube that defines a central conduit, wherein said first porous layer surrounds said base layer, and said solid layer surrounds said first porous layer.

12. A method of purifying hydrogen gas, comprising the steps of:

providing a hydrogen permeable structure having a porous layer of hydrogen permeable material covered by a solid layer of hydrogen permeable material;

exposing said hydrogen permeable structure to gas containing hydrogen gas; and

causing a pressure differential across the hydrogen permeable structure, wherein said hydrogen gas permeates through said hydrogen permeable structure and is collected.

13. The method according to Claim 12, wherein said hydrogen permeable structure is tubular and said step of exposing said hydrogen permeable structure includes passing gas through said hydrogen permeable structure under pressure.

14. The method according to Claim 12, further including the step of supporting said hydrogen permeable structure with a porous base layer of material.

15. The method according to Claim 12, wherein said hydrogen permeable material of said porous layer and said hydrogen permeable material of said solid layer are the same material.

16. A method of manufacturing a hydrogen gas separator, comprising the steps of:

forming a first porous layer from a hydrogen permeable material; and

depositing a solid layer of said hydrogen permeable material over said porous layer.

17. The method according to Claim 16, further including the step of forming contours in said solid layer.

18. The method according to Claim 16, further including the step of forming a second porous layer of said hydrogen permeable material, wherein said solid layer is interposed between said first porous layer and said second porous layer.

19. The method according to Claim 16, further including the step of forming a porous base layer of material and supporting said first porous layer with said porous base layer.

20. The method according to Claim 19 further including the step of bonding said first porous layer to said porous base layer.

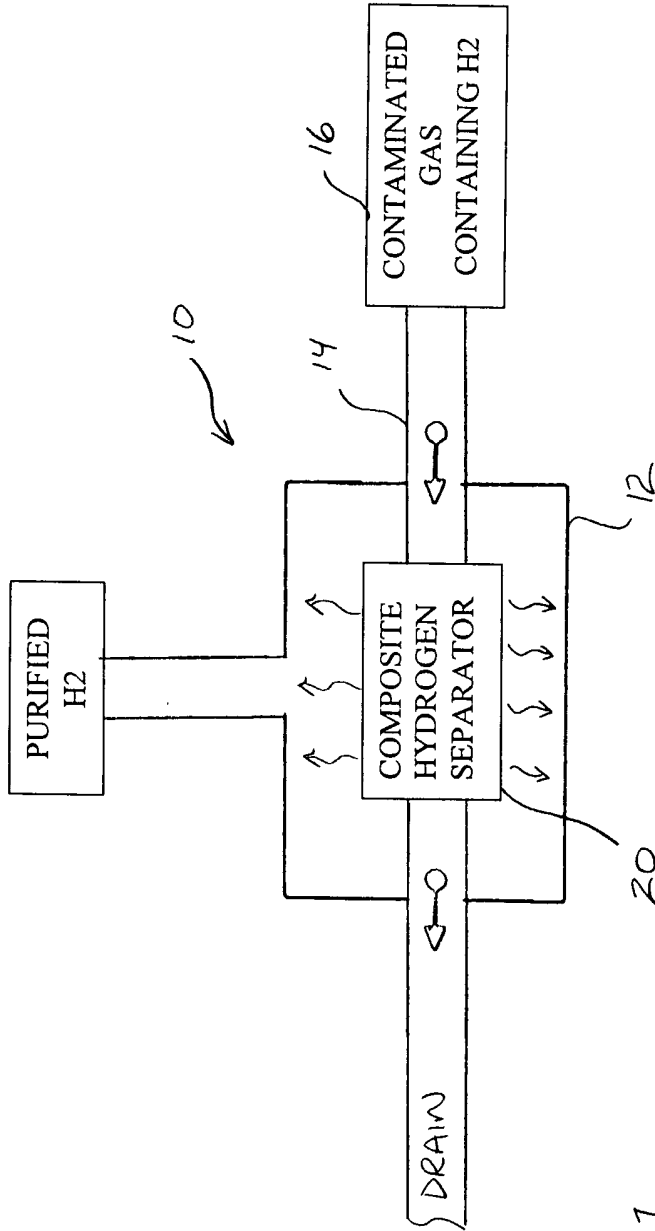

FIG. 1

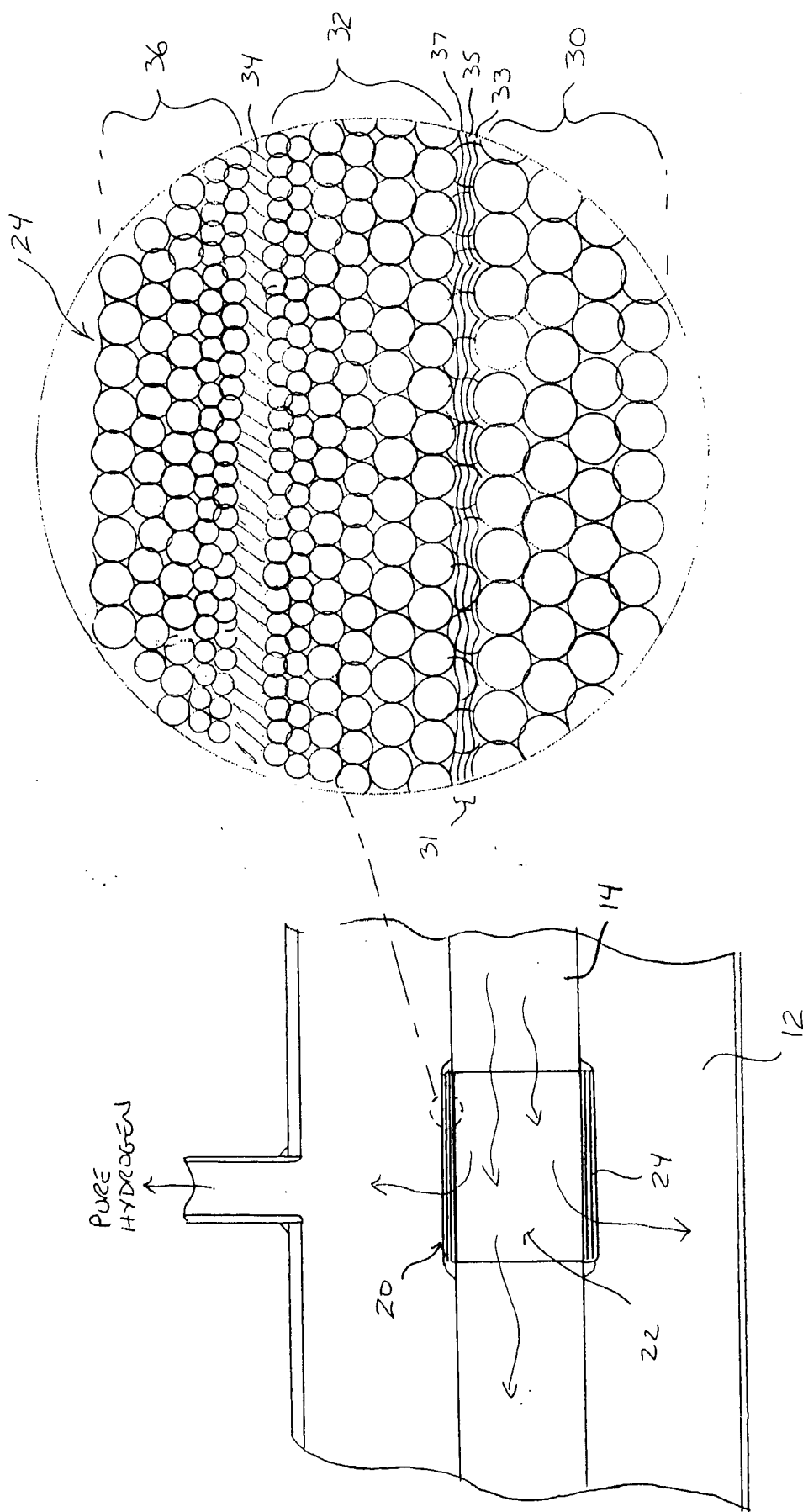

FIG. 2

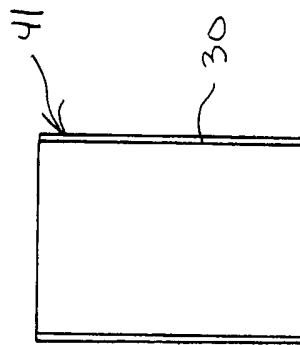

FIG. 3

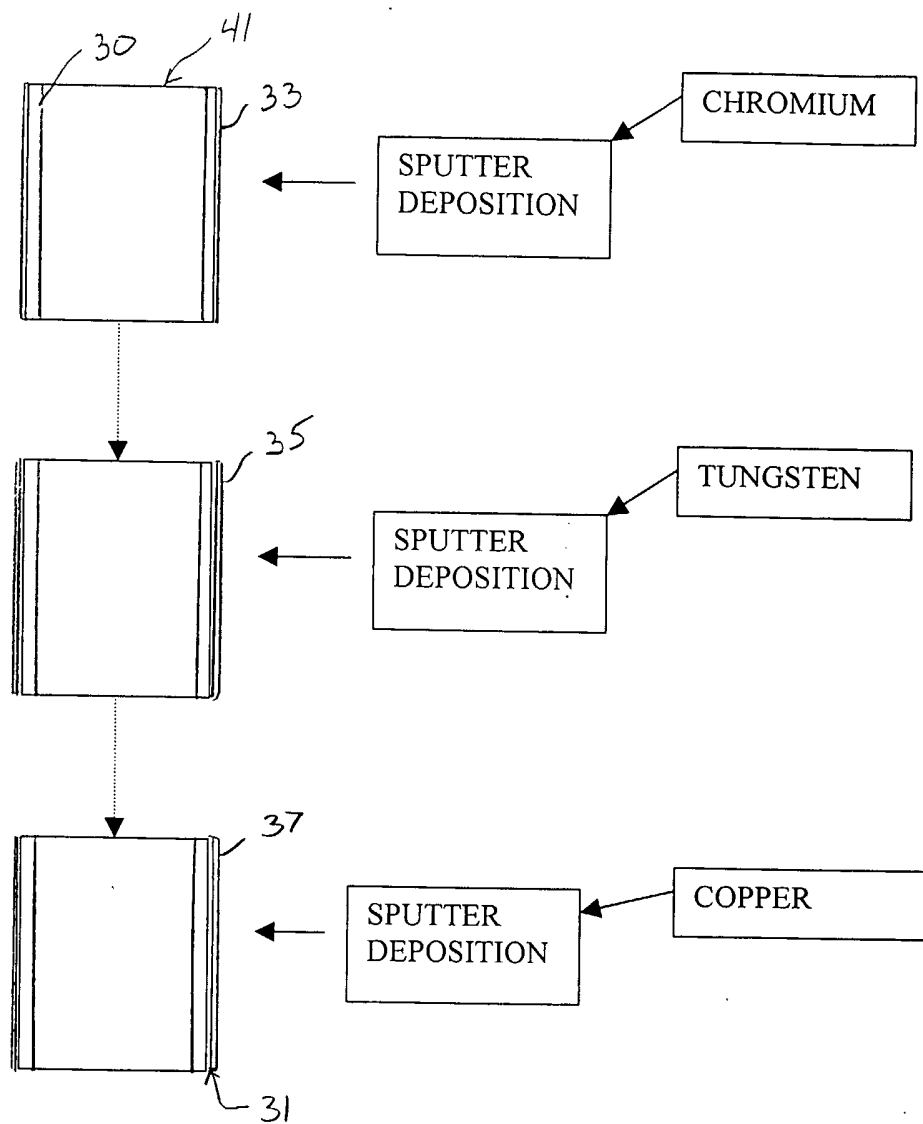

FIG. 4

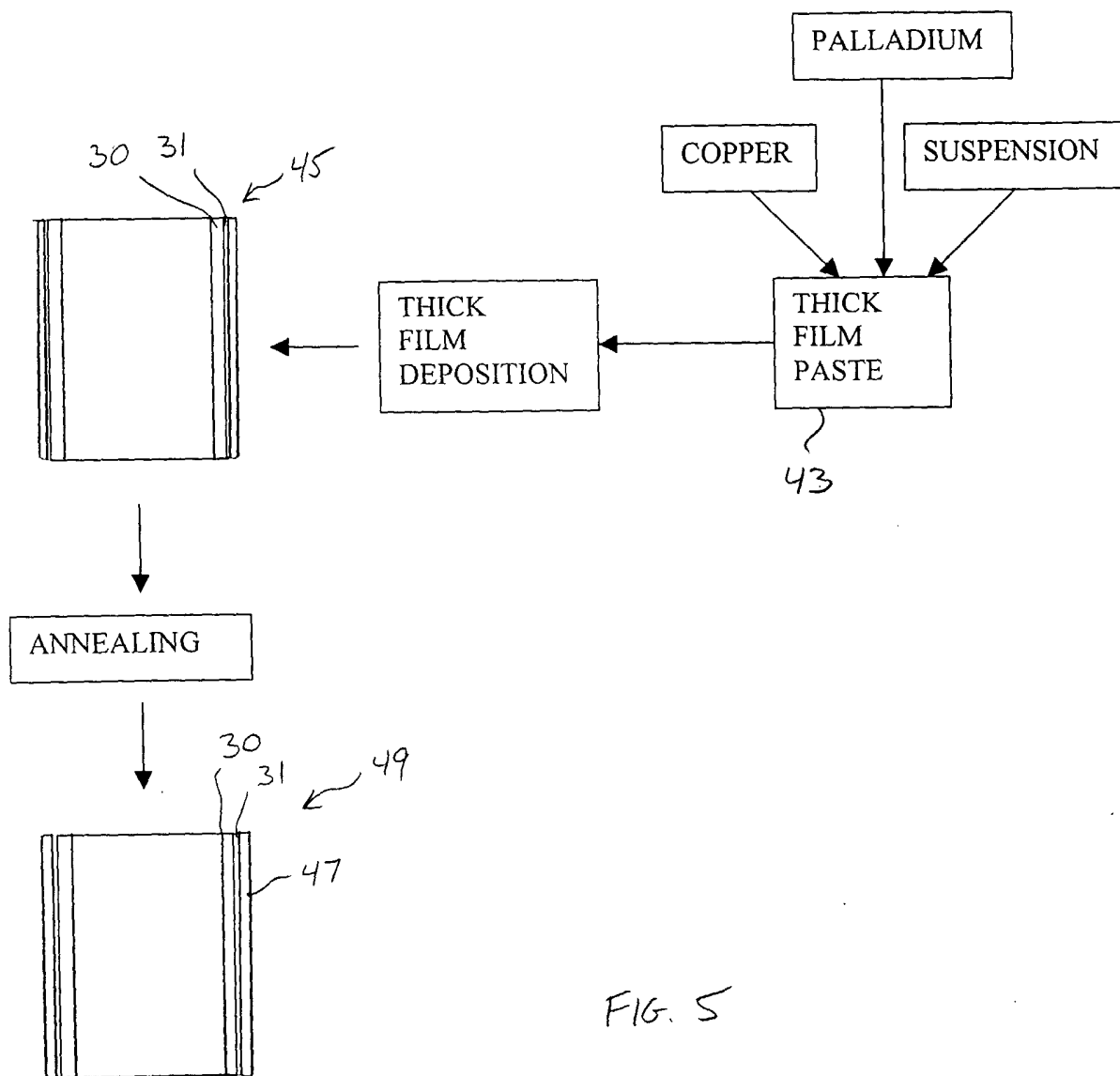

FIG. 5

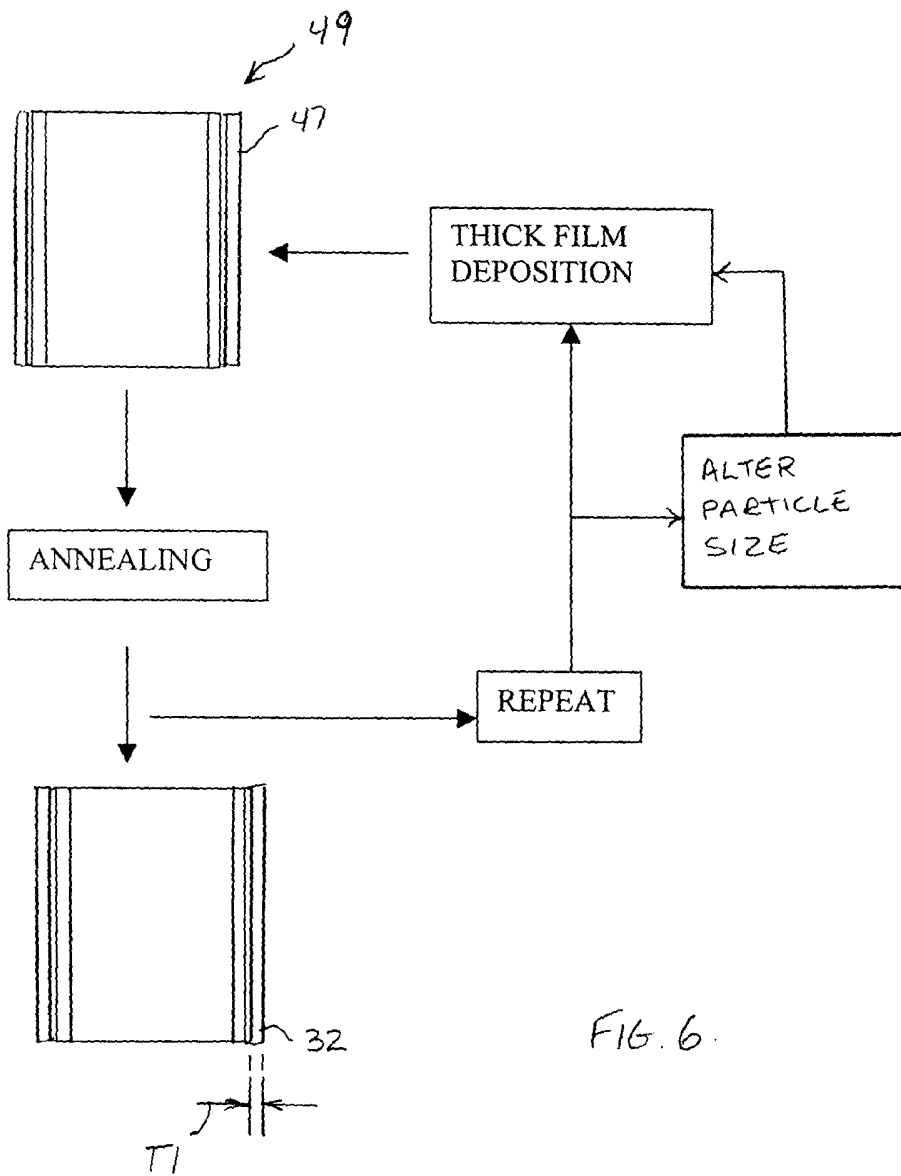

FIG. 6.

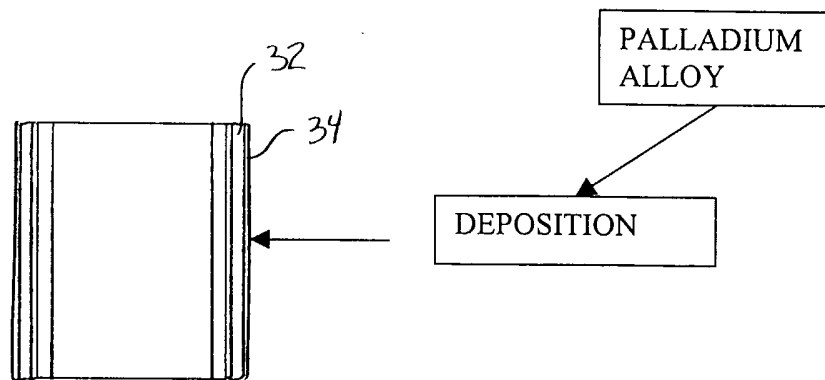

FIG. 7

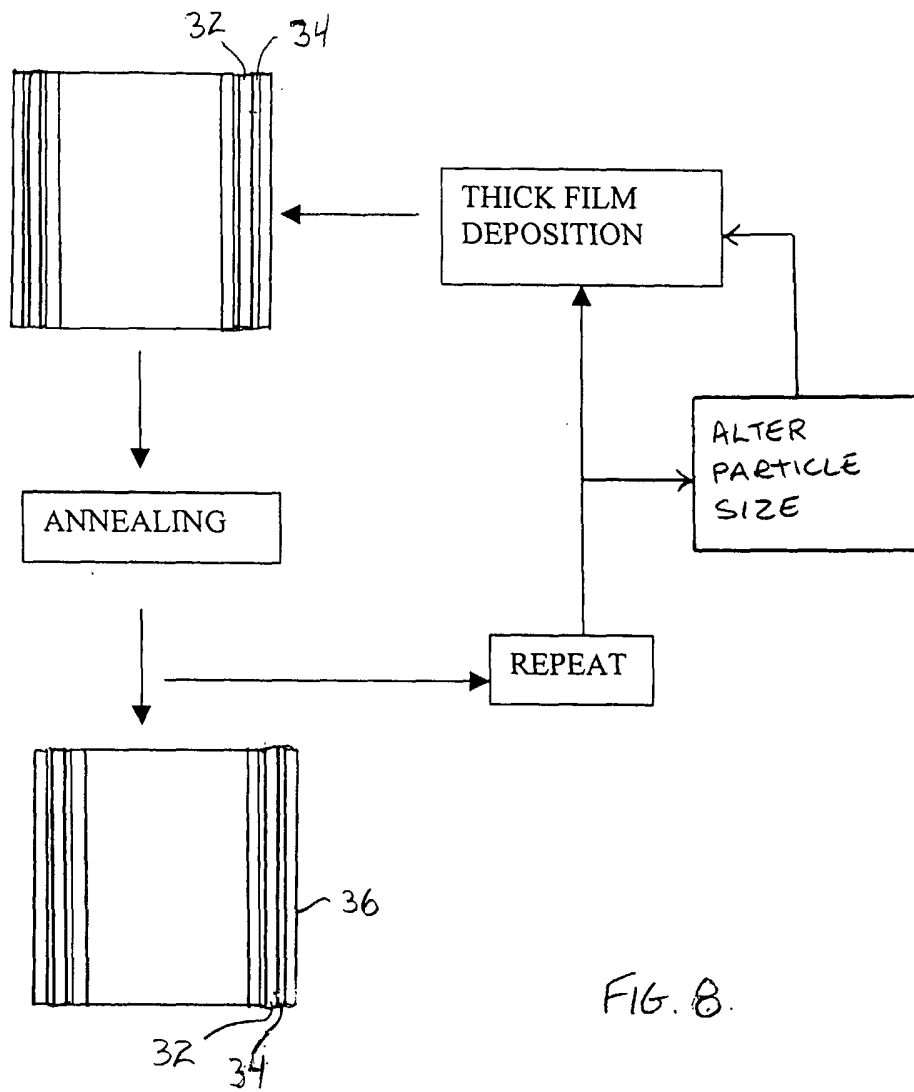

FIG. 8.

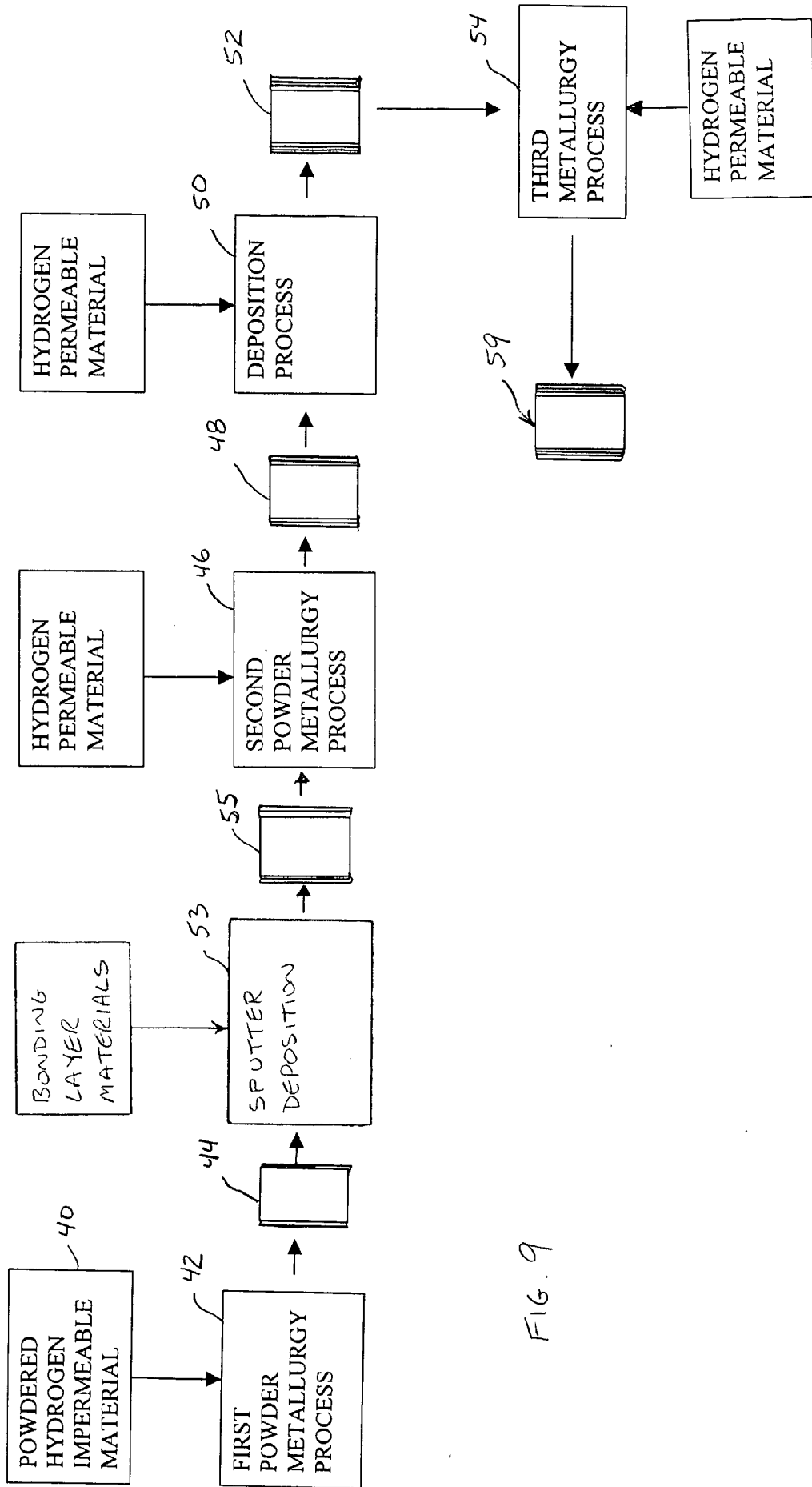

FIG. 9

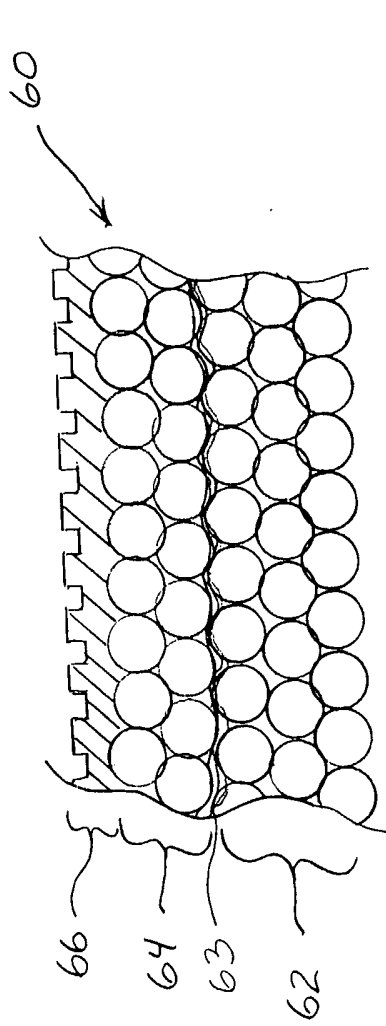

FIG. 10

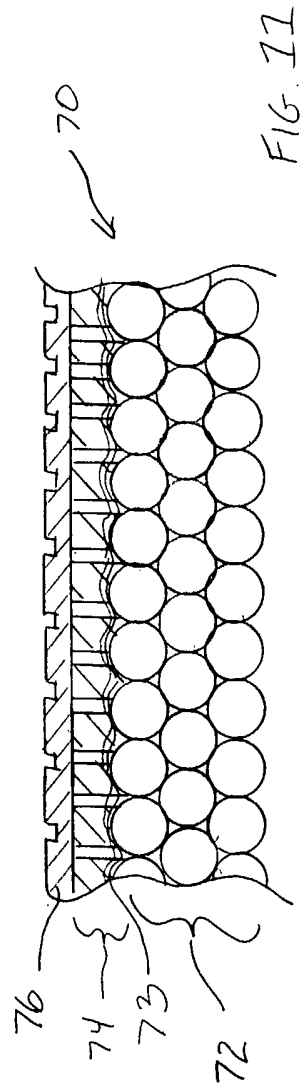

FIG. 11

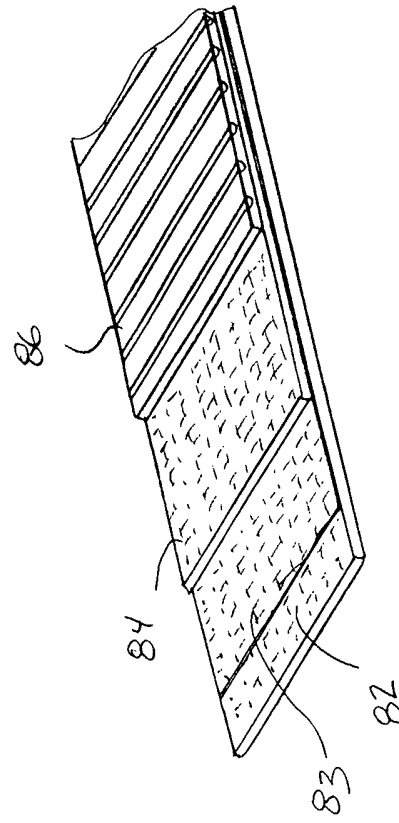

FIG. 12

INTERNATIONAL SEARCH REPORT

International application No.

PCT/US04/15300

A. CLASSIFICATION OF SUBJECT MATTER

IPC(7) : B01D 59/12, 53/22, 24/00, 39/14
 US CL : 96/4, 8, 10, 11; 95/55, 56; 55/524, Dig. 5

According to International Patent Classification (IPC) or to both national classification and IPC

B. FIELDS SEARCHED

Minimum documentation searched (classification system followed by classification symbols)
 U.S. : 96/4, 8, 10, 11; 95/55, 56; 55/524, Dig. 5

Documentation searched other than minimum documentation to the extent that such documents are included in the fields searched

Electronic data base consulted during the international search (name of data base and, where practicable, search terms used)

C. DOCUMENTS CONSIDERED TO BE RELEVANT

Category *	Citation of document, with indication, where appropriate, of the relevant passages	Relevant to claim No.
A	US 6,152,987 (MA et al.) 28 November 2000	1-20
A	US 5,734,092 A (WANG et al.) 31 March 1998	1-20

Further documents are listed in the continuation of Box C.

See patent family annex.

* Special categories of cited documents:	
"A" document defining the general state of the art which is not considered to be of particular relevance	"T" later document published after the international filing date or priority date and not in conflict with the application but cited to understand the principle or theory underlying the invention
"E" earlier application or patent published on or after the international filing date	"X" document of particular relevance; the claimed invention cannot be considered novel or cannot be considered to involve an inventive step when the document is taken alone
"L" document which may throw doubts on priority claim(s) or which is cited to establish the publication date of another citation or other special reason (as specified)	"Y" document of particular relevance; the claimed invention cannot be considered to involve an inventive step when the document is combined with one or more other such documents, such combination being obvious to a person skilled in the art
"O" document referring to an oral disclosure, use, exhibition or other means	"&" document member of the same patent family
"P" document published prior to the international filing date but later than the priority date claimed	

Date of the actual completion of the international search
 18 February 2005 (18.02.2005)

Date of mailing of the international search report
29 MAR 2005

Name and mailing address of the ISA/US
 Mail Stop PCT, Attn: ISA/US
 Commissioner for Patents
 P.O. Box 1450
 Alexandria, Virginia 22313-1450
 Facsimile No. (703) 305-3230

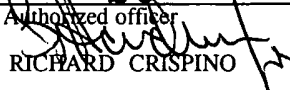
Authorized officer

 RICHARD CRISPINO
 Telephone No. 571 272-1700