



(11) **EP 1 615 275 A3**

(12) **EUROPEAN PATENT APPLICATION**

(88) Date of publication A3:
05.12.2007 Bulletin 2007/49

(51) Int Cl.:
H01L 51/40^(2006.01) H01L 27/15^(2006.01)

(43) Date of publication A2:
11.01.2006 Bulletin 2006/02

(21) Application number: **05021317.2**

(22) Date of filing: **27.06.2000**

(84) Designated Contracting States:
DE FR GB NL

(30) Priority: **28.06.1999 JP 18259899**

(62) Document number(s) of the earlier application(s) in accordance with Art. 76 EPC:
00113587.0 / 1 065 725

(71) Applicant: **SEMICONDUCTOR ENERGY LABORATORY CO., LTD.**
Atsugi-shi, Kanagawa-ken 243-0036 (JP)

(72) Inventors:
• **Yamzaki, Shunpei**
Atsugi-shi
Kanagawa-ken 243-0036 (JP)

- **Mizukami, Mayumi**
Atsugi-shi
Kanagawa-ken 243-0036 (JP)
- **Konuma, Toshimitsu**
Atsugi-shi
Kanagawa-ken 243-0036 (JP)

(74) Representative: **Grünecker, Kinkeldey, Stockmair & Schwanhäusser**
Anwaltssozietät
Maximilianstrasse 58
80538 München (DE)

(54) **Method of manufacturing an electro-optical device**

(57) An object of the invention is to reduce the manufacturing cost of EL display devices and electronic devices incorporating the EL display devices.

An EL material is formed by printing in an active matrix EL display device. Relief printing or screen printing may be used as the method of printing. Manufacturing steps of the EL layer is therefore simplified and reduction of manufacturing cost is devised.

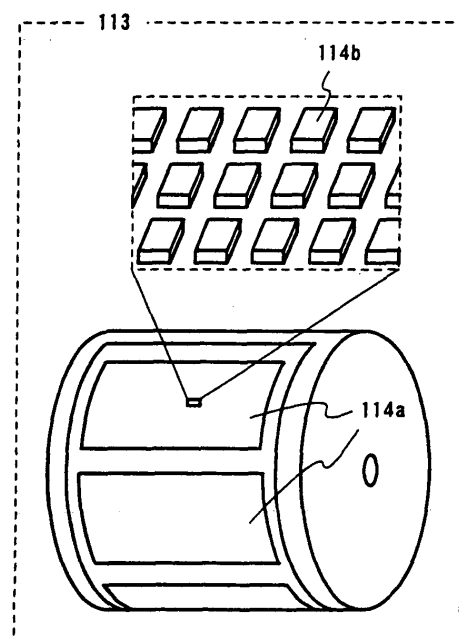

Fig. 1C

EP 1 615 275 A3



DOCUMENTS CONSIDERED TO BE RELEVANT			
Category	Citation of document with indication, where appropriate, of relevant passages	Relevant to claim	CLASSIFICATION OF THE APPLICATION (IPC)
X	EP 0 880 303 A (SEIKO EPSON CORP [JP]) 25 November 1998 (1998-11-25) * page 4, lines 35-37 * * page 5, lines 24-26 * * page 10, lines 52-55 - page 11, lines 2,3,13-15 * -----	1-5,13, 15,16	INV. H01L51/40 H01L27/15
A	JP 10 077467 A (SUMITOMO CHEMICAL CO) 24 March 1998 (1998-03-24) * figure 1 *	1-16	
A	JP 05 031882 A (NISSHA PRINTING) 9 February 1993 (1993-02-09) * abstract; figures 1,2 * -----	1-16	
			TECHNICAL FIELDS SEARCHED (IPC)
			H01L B41M
The present search report has been drawn up for all claims			
Place of search		Date of completion of the search	Examiner
The Hague		24 October 2007	Faou, Marylène
CATEGORY OF CITED DOCUMENTS			
X : particularly relevant if taken alone Y : particularly relevant if combined with another document of the same category A : technological background O : non-written disclosure P : intermediate document		T : theory or principle underlying the invention E : earlier patent document, but published on, or after the filing date D : document cited in the application L : document cited for other reasons & : member of the same patent family, corresponding document	

1
EPO FORM 1503 03.82 (P04C01)

**ANNEX TO THE EUROPEAN SEARCH REPORT
ON EUROPEAN PATENT APPLICATION NO.**

EP 05 02 1317

This annex lists the patent family members relating to the patent documents cited in the above-mentioned European search report. The members are as contained in the European Patent Office EDP file on
The European Patent Office is in no way liable for these particulars which are merely given for the purpose of information.

24-10-2007

Patent document cited in search report		Publication date	Patent family member(s)	Publication date
EP 0880303	A	25-11-1998	CN 1212114 A	24-03-1999
			CN 1523938 A	25-08-2004
			CN 1897295 A	17-01-2007
			CN 1905157 A	31-01-2007
			CN 1953239 A	25-04-2007
			DE 69727212 D1	19-02-2004
			DE 69727212 T2	04-11-2004
			DE 69736494 T2	15-02-2007
			WO 9824271 A1	04-06-1998
			JP 3899566 B2	28-03-2007
			JP 10153967 A	09-06-1998
			TW 553579 Y	11-09-2003
			US 2003054186 A1	20-03-2003

JP 10077467	A	24-03-1998	NONE	

JP 5031882	A	09-02-1993	JP 2079286 C	09-08-1996
			JP 7102694 B	08-11-1995
