



(12) **EUROPEAN PATENT APPLICATION**

(43) Date of publication:
10.06.2020 Bulletin 2020/24

(51) Int Cl.:
H04R 1/10 (2006.01)

(21) Application number: **18211033.8**

(22) Date of filing: **07.12.2018**

(84) Designated Contracting States:
AL AT BE BG CH CY CZ DE DK EE ES FI FR GB GR HR HU IE IS IT LI LT LU LV MC MK MT NL NO PL PT RO RS SE SI SK SM TR
 Designated Extension States:
BA ME
 Designated Validation States:
KH MA MD TN

(71) Applicant: **GN Audio A/S**
2750 Ballerup (DK)

(72) Inventor: **Birch, Ole**
2750 Ballerup (DK)

(54) **AN EARPHONE WITH A VENT**

(57) An earphone (1) comprising housing (2), a speaker (3), a speaker protrusion (4) extending along a protrusion axis (Z) and comprising an inner protrusion surface (12) and an outer protrusion surface (6), a resilient eargel (5) comprising an inner eargel surface (10) and an outer eargel surface (13). The eargel (5) is detachably attached to the speaker protrusion (4), such that the outer protrusion surface (6) abuts an abutment part (17) of the inner eargel surface (10) in an abutment zone (27) extending along the protrusion axis (Z). The eargel (5) is adapted to be inserted into the outer ear of a user, such that it abuts the ear canal of a user, whereby a cavity

(7) is provided between at least the speaker (3), the inner protrusion surface (12), the inner eargel surface (10) and the ear canal. The earphone (1) is provided with a vent channel (9) coupling the cavity (7) and the ambient, wherein the vent channel (9) comprises a groove (8) in the outer protrusion surface (6) or the inner eargel surface (10). The vent channel (9) is provided between a groove (8) in the outer protrusion surface (6) and the inner eargel surface (10) or between a groove (8) in the inner eargel surface (10) and the outer protrusion surface (6). The groove (8) comprises a first groove part (14), that extends in a plane orthogonal to the protrusion axis (Z).

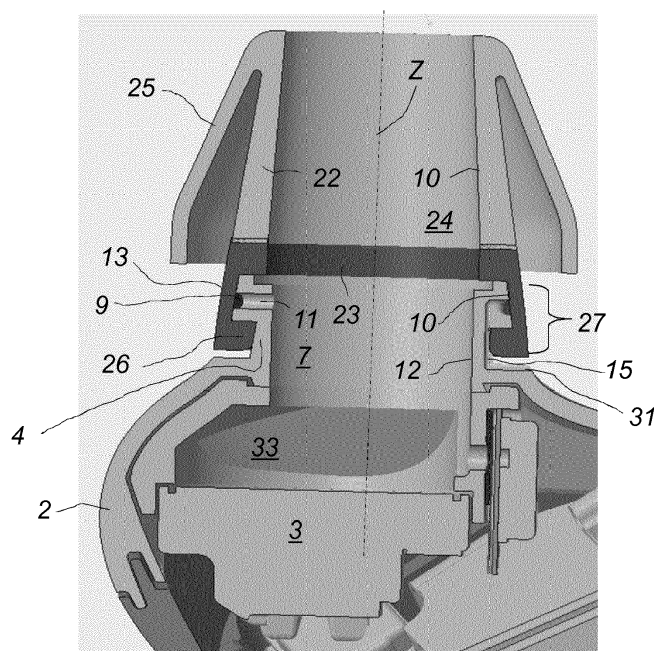

Fig. 7

DescriptionTechnical Field

5 **[0001]** The invention relates to an earphone comprising housing, a speaker, a speaker protrusion extending along a protrusion axis and comprising an inner protrusion surface and an outer protrusion surface, a resilient eargel comprising an inner eargel surface and an outer eargel surface, whereby the eargel is detachably attached to the speaker protrusion, such that the outer protrusion surface abuts a part of the inner eargel surface in an abutment zone, the eargel being adapted to be inserted into the outer ear of a user, such that the outer eargel surface abuts the ear canal of a user, whereby a cavity is provided between the speaker, the inner protrusion surface, the inner eargel surface and the ear canal, and wherein the earphone is provided with a leakage hole/vent coupling the cavity and the ambient, wherein the vent comprises a groove in the outer protrusion surface or the inner eargel surface, whereby a vent channel is provided between the groove and the inner eargel surface or the outer protrusion surface.

15 Background Art

[0002] An earphone of type mentioned above can be used for listening to audio, such as music. If it is embodied as a headset or being a part of a headset, it can be used two-way communication. It can be corded and plugged into a smartphone or computer, or it can be wireless and be provided with a transceiver, such as a Bluetooth transceiver. An earphone of this type can fit sealing in the in the entrance of the ear canal, which can give some advantage but also some disadvantages. An advantage is that ambient noise can be blocked out ensuring that the user better can hear the audio generated by the speaker in noisy conditions. Another advantage is, that less energy is needed to provide high quality sound especially at lower frequencies. A disadvantage is, that a high air pressure may occur in the ear canal, when the eargel is inserted, which may cause discomfort for the user and/or damage the speaker membrane and/or decrease the sound quality. Therefore, it is desired to provide a controlled vent which provides pressure equalising without eliminating the positive acoustic properties provided by a sealed/closed fitting.

20 **[0003]** US 7,784,583 discloses an earphone type of type above with a vent provided as a thin channel extending in the eargel between the cavity and ambient. US 9,237,39 discloses an earphone of the type above, where a groove is provided in the inner surface of the eargel, whereby a vent channel is provided between the eargel and the outer protrusion surface. Also, US 8,189,846 BB discloses an earphone, wherein a vent channel is provided on the inner side of the eargel.

Disclosure of Invention

35 **[0004]** The earphone according to the preliminary part is characterised in that the groove comprises a first groove part, that extends in a plane orthogonal to the protrusion axis. Such a channel is easy to provide during manufacturing of the speaker protrusion or the eargel, and because a first groove part extends in a plane orthogonal to the protrusion axis, a certain length of the channel can be obtained without making the speaker protrusion unnecessary long.

[0005] According to an embodiment, the first groove part has a length of at least 5 mm, 10 mm, 12 mm, 16 mm or 20 mm.

40 **[0006]** According to an embodiment, the first groove part extends in the outer protrusion surface and at least along a fourth, a third or half of periphery of the outer protrusion surface.

[0007] According to an embodiment, the first groove part communicates with a through-going bore connecting the inner protrusion surface and the outer protrusion surface.

[0008] According to an embodiment, a second groove part extends in the outer protrusion surface from the first groove part along the protrusion axis beyond the abutment zone.

45 **[0009]** According to an embodiment, cross-section of the vent channel is less than 2 mm², 1 mm², 0,8 mm² or 0,5 mm².

[0010] According to an embodiment, the first groove part is provided in the inner eargel surface.

[0011] According to an embodiment, the abutment zone extends along the full length of the speaker protrusion.

[0012] According to an embodiment, the second groove part extends into the outer side of the housing.

[0013] According to an embodiment, the speaker protrusion has an oval cross-section.

50 **[0014]** According to an embodiment, the vent channel is dimensioned to provide a cut-off frequency of approximately 20 Hz.

[0015] According to an embodiment, a feedback active noise cancelling microphone is provided in the earphone housing.

55 **[0016]** The invention also relates to headset comprising an earphone described above and at least one voice microphone for picking up voice of a user of the headset.

Brief Description of the Drawings

[0017] The invention is explained in detail below with reference to the drawing illustrating a preferred embodiment of the invention and in which

- 5 Fig. 1 is a perspective view of an earphone with a speaker protrusion and an eargel according to a first embodiment of the invention,
 Fig. 2 is another perspective of the earphone,
 Fig.3 is a top view of the earphone,
 10 Fig. 4 is a perspective view of the headset with the eargel removed,
 Fig. 5 is a perspective view of the area with the speaker protrusion,
 Fig. 6 is the area of fig. 5 shown from another angle,
 Fig. 7 is a cross-sectional view through the speaker protrusion and the eargel,
 Fig. 8 is a cross-sectional view through the eargel, and
 15 Fig. 9 is a cross-sectional view through a second embodiment.
 Fig. 10 is another cross-sectional view through the second embodiment.

Modes for Carrying out the Invention

20 **[0018]** Figs. 1 and 2 are perspective views of an earphone 1 with a speaker protrusion and an eargel 5 according to a first embodiment of the invention. The earphone 1 is embodied as a wireless headset for two-way communication. The headset 1 comprises a housing 2, a speaker protrusion 4 and an eargel 5 of resilient material attached to the speaker protrusion 4. The housing 4 holds a speaker, signal processing electronics, a DA/AD converter, a rechargeable battery, a Bluetooth™ transceiver etc. Microphone openings 16 in the housing 2 provides acoustic access to the microphone(s).
 25 The headset 1 is a part of a "truly wireless" headset comprising two earphones 1, one for each ear. They both communicate via the Bluetooth™ standard with a smartphone or the like. However, they could also have been adapted to communicate directly with each other, f. ex. by magnetic induction. The headset 1 shown in Fig. 1 can also be used alone as a monaural headset. After insertion of the eargel 5 into the ear canal of the user, the headset 1 remains in place due to friction between a deformable eargel skirt 25 of the eargel 5 and the internal wall of the ear canal opening. The headset 1 is
 30 adapted to be used with the right ear of a user.

[0019] Fig. 3 is a top view of the earphone 1. The speaker protrusion 4 and the eargel 5 have oval cross-sections. Charging terminals 19 are provided for charging the battery of the headset 1. A sound outlet 20 of the eargel 5 conducts audio from the speaker to the ear canal of the user during use.

[0020] Fig. 4 is a perspective view of the headset 1 with the eargel 5 removed. The eargel 3 can be replaced with another eargel of a different size in order to adapt the headset 1 to the user's ear. Or it can be taken of to be cleaned or replaced due to wear. The speaker protrusion 4, which is an integral part of the housing 2, is approximately 2.7 mm high in the Z-direction. It has a stem part 21 and a rim part 18 with a larger diameter than the stem part 21. The stem part 21 is approximately 7.8 mm wide at the widest place and 5.4 mm wide at the narrowest place. The rim part 18 is approximately 1.5 mm high in the Z-direction. It is approximately 9 mm wide at the widest place and approximately 6.6
 40 mm wide at the narrowest place. The internal diameter of the protrusion 4 varies between approximately 4.0 mm and 6.4 mm. A through-going bore 11 in the rim part 18 and a groove 8 in the outer protrusion surface of rim part 18 will be explained further below in relation to the description of Figs. 5 and 6.

[0021] Fig. 8 is a cross-sectional view of the eargel 5. The eargel 5 has a core part 22 and an outer eargel skirt 25. The eargel 5 is divided in to a stiff portion 23 and a soft portion 24. The soft portion 24 comprise an upper part of the core portion 22 and the thin-walled flexible eargel skirt 25. The lower, stiff part 23 of the core portion 22 is made of a more rigid material and co-molded with the soft part 24. The eargel skirt 25 adapts to the entrance of the ear canal when inserted to provide a close fit. The stiff part 23 of the core portion 22 is having a core recession 32 and a lower core rim 26.
 45

[0022] Figs. 5 and 6 are different a perspective views of the area with the speaker protrusion 4. The speaker protrusion 4 has a stem part 21 and a rim part 18 with a larger diameter than the stem part 21. The rim part 18 of the speaker protrusion 4 is adapted to be received in the eargel recession 32 of the eargel 5. The rigid core part 23 is resilient enough to be expanded when the eargel 4 is attached to the speaker protrusion 4. The outer protrusion surface 6 has a first groove part 14 and a second grove part 15. The first groove part 14 extends approximately 180 degrees around the periphery of the speaker protrusion 4 in a plane approximately orthogonal to the speaker protrusion axis Z. The first groove part 14 is approximately 0.5 mm wide and 0.25 mm deep. At one end the first groove part 14 communicates with the second groove part 15, which extends approximately parallel to the protrusion axis Z to an outlet 31 beyond the stem part 21. The other end of the first groove part 14 communicates with a through-going bore 11 going from the outer protrusion surface 6 to the inner protrusion surface 12. The bore has a diameter of approximately 0.5 mm.
 50

[0023] When the eargel 5 is attached to the protrusion 4, a vent channel 9 is provided from the inside of the speaker

protrusion 4 to the ambient. This vent channel 9 is delimited by the bore 11, the first and second groove parts 14, 15 and the rigid core part 23 of the eargel 5.

[0024] Fig. 7 is a cross-sectional view through the speaker protrusion 4 and the eargel 5. The speaker 3 is shown schematically inside the housing 2. To the left of the protrusion axis Z, the bore 11 is visible. To the right of the protrusion axis Z, the second groove part 15 and the outlet 31 in the housing 2 are visible. The first groove part 14 extends between the bore 11 and the second groove part 15 behind the plane of Fig. 7. When the earphone 1 is inserted into the ear of a user, a "front chamber" or cavity 7 is established between the speaker 7, a front chamber wall 33, the inner protrusion surface 12, the inner eargel surface 10 and the user's ear. During the insertion into the ear, the air pressure in the cavity would rise if the headset 1 was not provided with the vent channel 9. If there were no vent channel, the high air pressure could cause discomfort for the user, as the eardrum would be exposed to a high pressure. Also, the speaker diaphragm could be exposed to such a high pressure, that the it could break. The vent channel 9 has a length of 12 mm and it therefore acts as a low-pass filter, which in practice only lets sounds with frequencies below 20 HZ pass. Thus, the air pressure is equalised with the ambient air pressure in real time. However, as only very low frequencies pass the vent channel, the cavity is in practice acoustically closed. Thus, the acoustic advantages of a closed cavity are maintained. The low pass filter characteristics of channel 9 are determined by the length and the cross section. A cut-off frequency of 20 Hz could also have been obtained by a much shorter channel if the cross section was much smaller also. However, a channel running parallel with the speaker protrusion axis Z alone would have such a small cross sectional, that it could be problematic to manufacture products with uniform properties, as tolerances and worn moulds would affect the properties.

[0025] Figs. 9 and 10 are schematic cross-sectional views of an alternative embodiment. Here the first groove part 14 is provided in the inner eargel surface 10. One end of the first groove part 14 communicates with a bore 30 in the core part 22 of the eargel. The other end of the first groove part 14 communicates with a first bore 28 in the speaker protrusion 4. As the core part 22 and the speaker protrusion 4 have oval cross-sections, the eargel 4 can be attached in two positions, which are displaced 180 degrees in relation to each other. If the eargel is attached in the other position as shown in Fig. 10, the first groove part 14 will communicate with a second bore 29 in the speaker protrusion. Thus, a vent channel will be provided in any case, so the user can not attach the eargel in a wrong way.

[0026] The cross-sections of the speaker protrusion 4 and the eargel 5 can have other shapes and f. ex. be circular.

Reference signs:

30	Z	speaker protrusion axis	27	abutment zone
	1	Headset	28	first bore in speaker
	2	Housing		protrusion
	3	Speaker	29	second bore in speaker
35	4	Speaker protrusion		protrusion
	5	Eargel	30	outlet in core part
	6	outer protrusion surface	31	outlet in housing
	7	cavity	32	core recession
	8	groove	33	front chamber wall
40	9	vent channel		
	10	inner eargel surface		
	11	through-going bore		
	12	inner protrusion surface		
45	13	outer eargel surface		
	14	first groove part		
	15	second groove part		
	16	microphone openings		
	17	abutment part of inner		
50		eargel surface		
	18	rim part of speaker		
		protrusion		
	19	charging terminals		
55	20	sound outlet		
	21	stem part of protrusion		
	22	core part		
	23	stiff portion of core part		

(continued)

	24	soft portion eargel
	25	eargel skirt
5	26	core rim

Claims

- 10 1. An earphone (1) comprising housing (2), a speaker (3), a speaker protrusion (4) extending along a protrusion axis (Z) and comprising an inner protrusion surface (12) and an outer protrusion surface (6), a resilient eargel (5) comprising an inner eargel surface (10) and an outer eargel surface (13), wherein the eargel (5) is detachably attached to the speaker protrusion (4), such that the outer protrusion surface (6) abuts an abutment part (17) of the inner eargel surface (10) in an abutment zone (27) extending along the protrusion axis (Z), the eargel (5) being adapted to be inserted into the outer ear of a user, such that it abuts the ear canal of a user, whereby a cavity (7) is provided between at least the speaker (3), the inner protrusion surface (12), the inner eargel surface (10) and the ear canal, and wherein the earphone (1) is provided with a vent channel (9) coupling the cavity (7) and the ambient, wherein the vent channel (9) comprises a groove (8) in the outer protrusion surface (6) or the inner eargel surface (10), the vent channel (9) being provided between a groove (8) in the outer protrusion surface (6) and the inner eargel surface (10) or between a groove (8) in the inner eargel surface (10) and the outer protrusion surface (6), **characterized in that** the groove (8) comprises a first groove part (14), that extends in a plane orthogonal to the protrusion axis (Z).
- 15
- 20 2. An earphone (1) according to claim 1 or two, wherein the first groove part (14) has a length of at least 5 mm, 10 mm, 12 mm, 16 mm or 20 mm.
- 25 3. An earphone (1) according to claim 1 or 2, wherein the first groove part (14) extends in the outer protrusion surface (6) and at least along a fourth, a third or half of periphery of the outer protrusion surface (6).
- 30 4. An earphone (1) according to claim 3, wherein the first groove part (14) communicates with a through-going bore (11) connecting the inner protrusion surface (12) and the outer protrusion surface (6).
- 35 5. An earphone (1) according to claim 4, wherein a second groove part (15) extends in the outer protrusion surface (6) from the first groove part (14) along the protrusion axis (Z) beyond the abutment zone (27).
- 40 6. An earphone (1) according to any of the preceding claims, wherein the cross-section of the vent channel (9) is less than 2 mm², 1 mm², 0,8 mm² or 0,5 mm².
- 45 7. An earphone (1) according to claim 1 or 2, wherein the first groove part (14) is provided in the inner eargel surface (10).
8. An earphone (1) according to any of the preceding claims, wherein the abutment zone (27) extends along the full length of the speaker protrusion (4).
9. An earphone (1) according to claim 4 and 8, wherein the second groove part (15) extends into the outer side of the housing (2).
- 50 10. An earphone (1) according to any of the preceding claims, wherein the speaker protrusion (4) has an oval cross-section.
11. An earphone (1) according to any of the preceding claims, wherein the vent channel (9) is dimensioned to provide a cut-off frequency of approximately 20 Hz.
- 55 12. An earphone (1) according to any of the preceding claims, wherein a feedback active noise cancelling microphone is provided in the earphone housing (2).
13. A headset (1) comprising an earphone according to any of the preceding claims and at least one voice microphone (16) for picking up voice of a user of the headset (1).

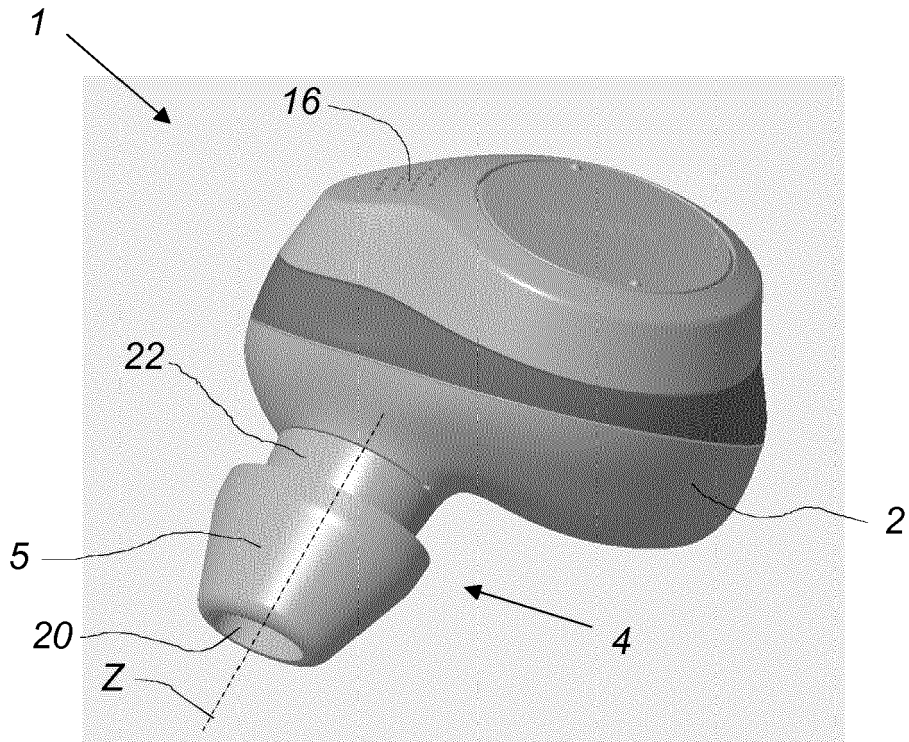

Fig. 1

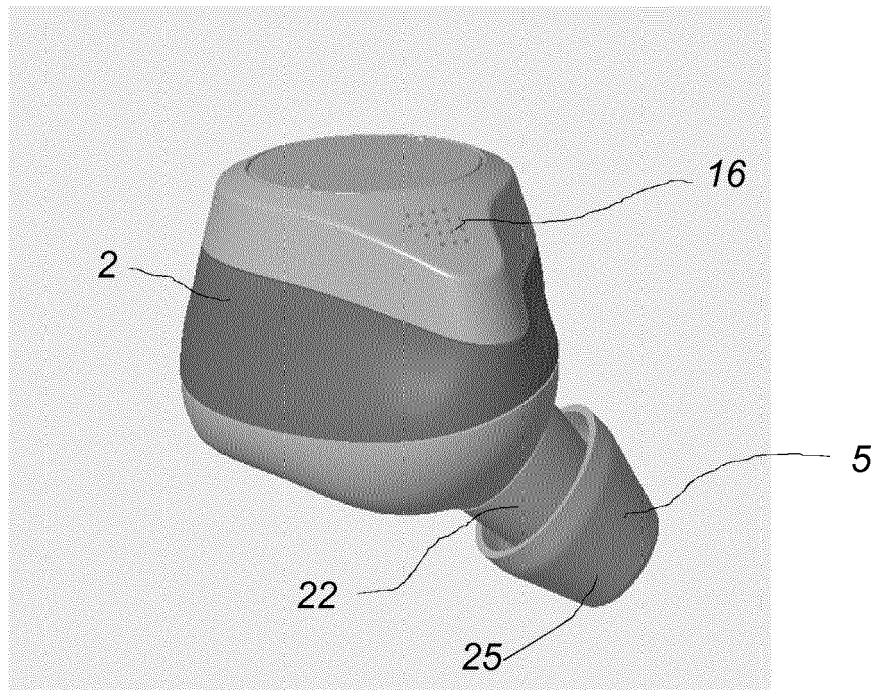

Fig. 2

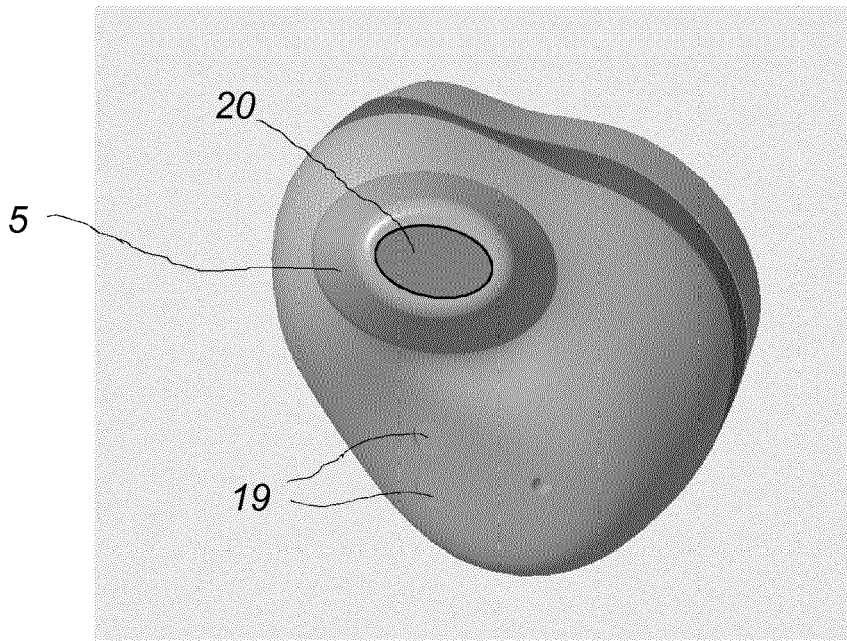

Fig. 3

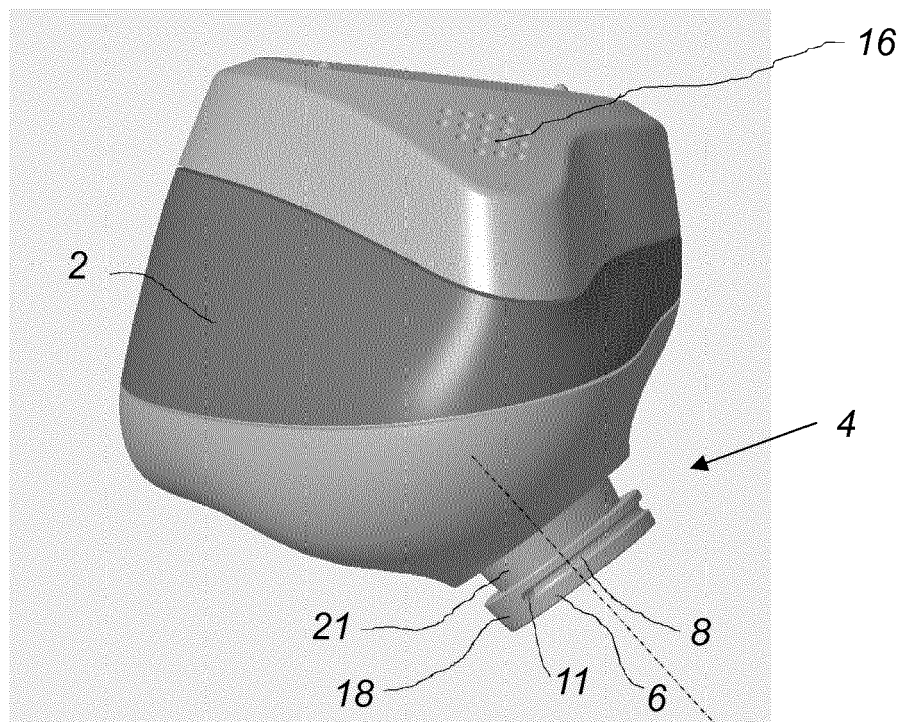

Fig. 4

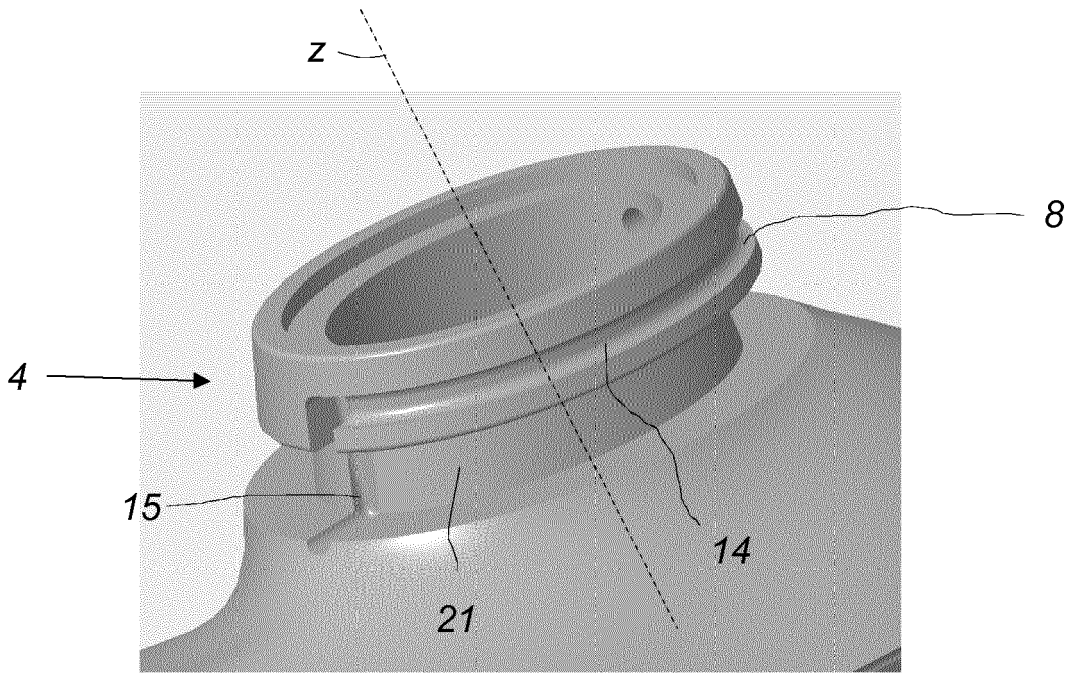

Fig. 5

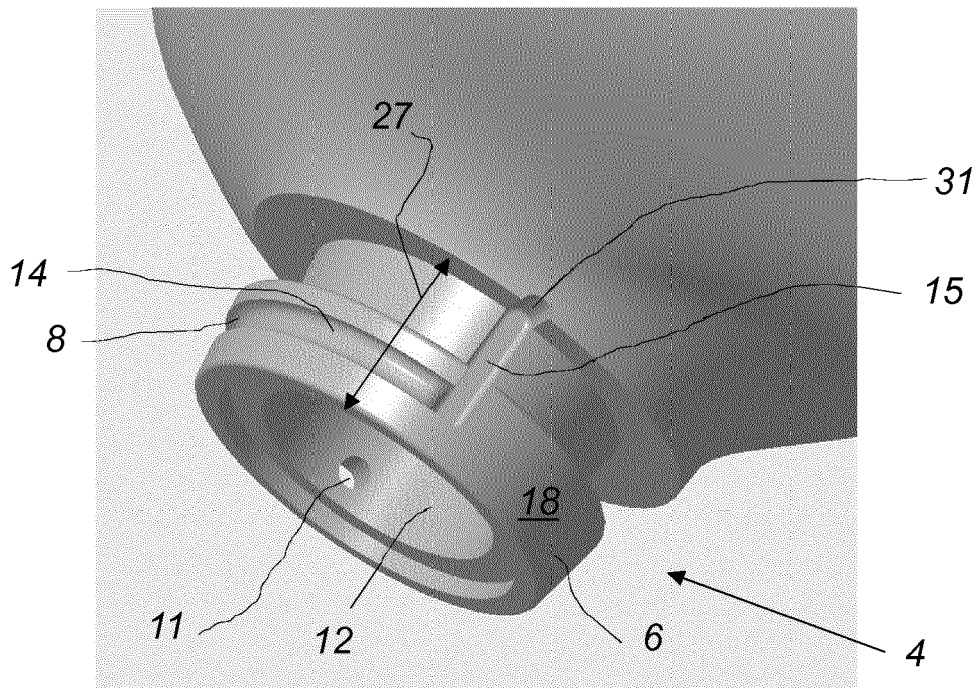

Fig. 6

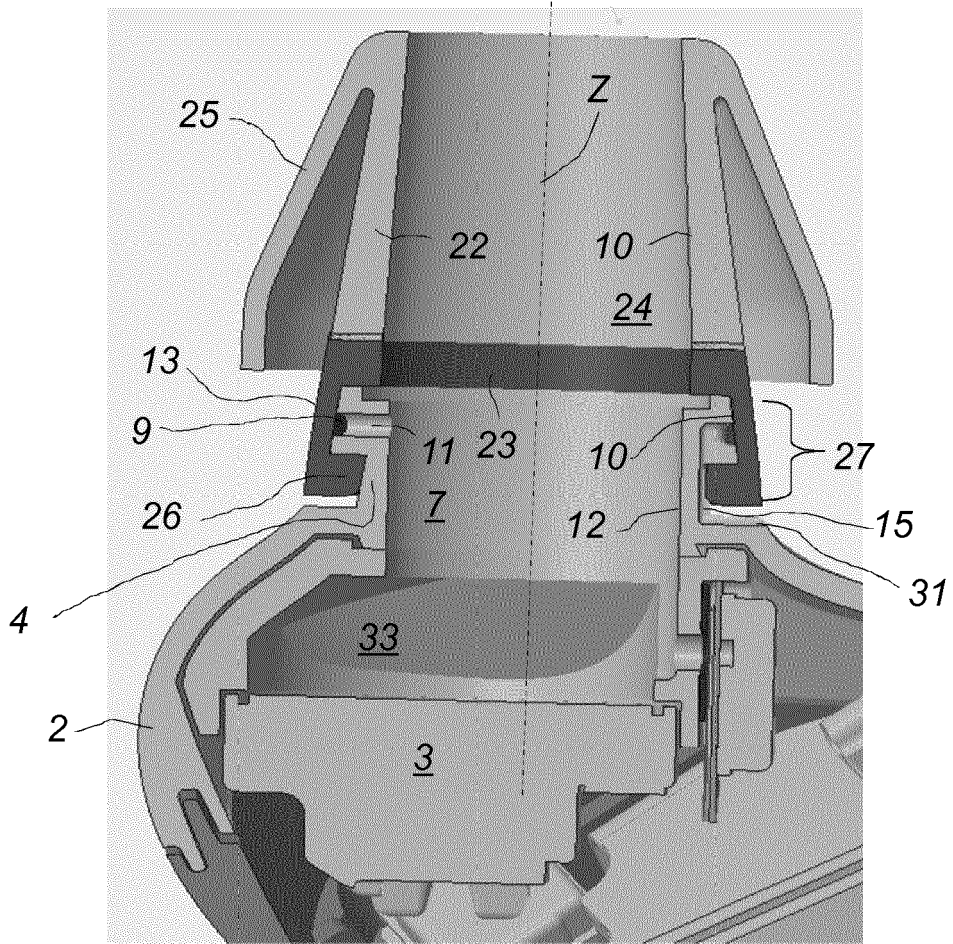

Fig. 7

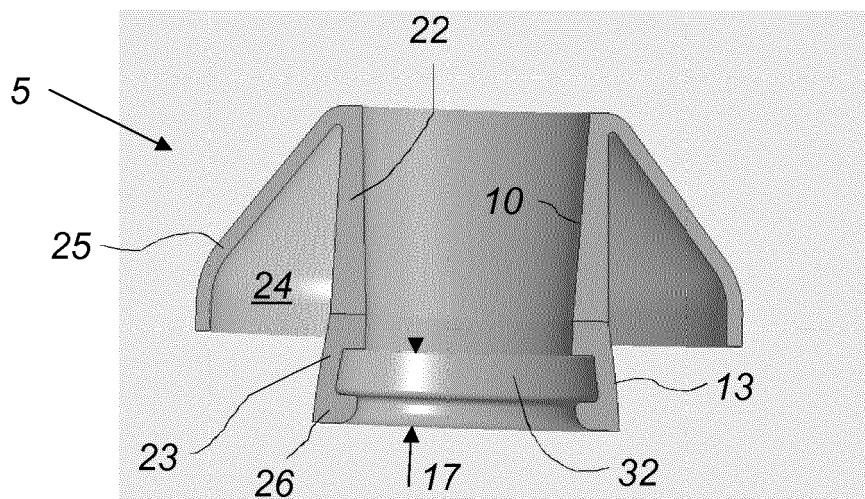

Fig. 8

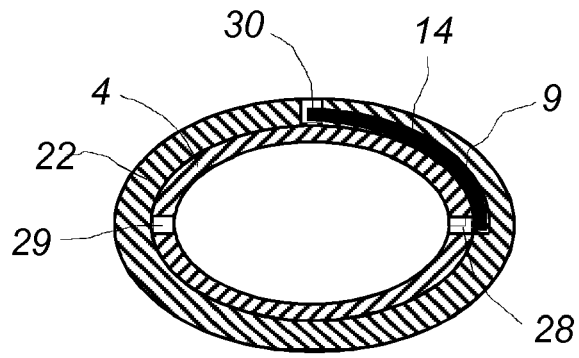

Fig. 9

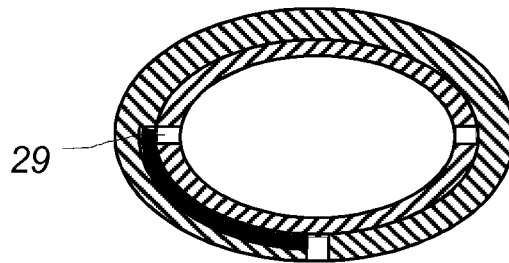

Fig. 10



EUROPEAN SEARCH REPORT

Application Number
EP 18 21 1033

5

10

15

20

25

30

35

40

45

50

55

DOCUMENTS CONSIDERED TO BE RELEVANT			
Category	Citation of document with indication, where appropriate, of relevant passages	Relevant to claim	CLASSIFICATION OF THE APPLICATION (IPC)
X,D	US 9 237 394 B2 (BUJEON CO LTD [KR]) 12 January 2016 (2016-01-12)	1,7,10	INV. H04R1/10
Y	* abstract *	12,13	
A	* column 1, line 41 - column 2, line 17; figure 1 *	2-6,8,9, 11	

X	JP 2015 109542 A (PANASONIC IP MAN CORP) 11 June 2015 (2015-06-11)	1,3-6, 8-10	
Y	* paragraph [0081] - paragraph [0082];	12,13	
A	figures 18,19 *	2,7,11	

Y	US 2018/020281 A1 (WURTZ MICHAEL JON [US] ET AL) 18 January 2018 (2018-01-18)	12,13	
A	* abstract *	1	
	* paragraph [0023]; figure 2 *		

A	EP 2 736 267 A1 (PANASONIC CORP [JP]) 28 May 2014 (2014-05-28)	1-13	
	* abstract *		
	* paragraph [0022] - paragraph [0027]; figure 1 *		

The present search report has been drawn up for all claims			TECHNICAL FIELDS SEARCHED (IPC)
			H04R
Place of search		Date of completion of the search	Examiner
Munich		13 May 2019	Gerken, Stephan
CATEGORY OF CITED DOCUMENTS			
X : particularly relevant if taken alone		T : theory or principle underlying the invention	
Y : particularly relevant if combined with another document of the same category		E : earlier patent document, but published on, or after the filing date	
A : technological background		D : document cited in the application	
O : non-written disclosure		L : document cited for other reasons	
P : intermediate document		& : member of the same patent family, corresponding document	

EPO FORM 1503 03/82 (P04/C01)

**ANNEX TO THE EUROPEAN SEARCH REPORT
ON EUROPEAN PATENT APPLICATION NO.**

EP 18 21 1033

5 This annex lists the patent family members relating to the patent documents cited in the above-mentioned European search report.
The members are as contained in the European Patent Office EDP file on
The European Patent Office is in no way liable for these particulars which are merely given for the purpose of information.

13-05-2019

Patent document cited in search report	Publication date	Patent family member(s)	Publication date
US 9237394 B2	12-01-2016	KR 101423881 B1 US 2014348372 A1	25-07-2014 27-11-2014
-----	-----	-----	-----
JP 2015109542 A	11-06-2015	NONE	
-----	-----	-----	-----
US 2018020281 A1	18-01-2018	US 2018020281 A1 WO 2017147545 A1	18-01-2018 31-08-2017
-----	-----	-----	-----
EP 2736267 A1	28-05-2014	EP 2736267 A1 JP 5914887 B2 JP WO2013014852 A1 US 2013148830 A1 WO 2013014852 A1	28-05-2014 11-05-2016 23-02-2015 13-06-2013 31-01-2013
-----	-----	-----	-----

EPO FORM P0459

For more details about this annex : see Official Journal of the European Patent Office, No. 12/82

REFERENCES CITED IN THE DESCRIPTION

This list of references cited by the applicant is for the reader's convenience only. It does not form part of the European patent document. Even though great care has been taken in compiling the references, errors or omissions cannot be excluded and the EPO disclaims all liability in this regard.

Patent documents cited in the description

- US 7784583 B [0003]
- US 923739 A [0003]
- US 8189846 BB [0003]