



US007222537B2

(12) **United States Patent**
Lehmann et al.

(10) **Patent No.:** **US 7,222,537 B2**
(45) **Date of Patent:** **May 29, 2007**

(54) **METHOD OF MONITORING PRESSURE OF A GAS SPECIES AND APPARATUS TO DO SO**

7,067,323 B2 6/2006 Veale et al.

(Continued)

(75) Inventors: **Martin Lehmann**, Obere Fahrbühlstrasse 1 CH-5610, Wohlen AG (CH); **Jean-Noel Fehr**, Palezieux-Village (CH); **Martin Liechti**, Bern (CH); **Urban Schnell**, INS (CH)

FOREIGN PATENT DOCUMENTS

EP 1 450 139 A2 8/2004

(Continued)

(73) Assignee: **Martin Lehmann**, Wohlen AG (CH)

OTHER PUBLICATIONS

L.C. Philippe and R.K. Hanson, Laser diode wavelength-modulation spectroscopy for simultaneous measurement of temperature, pressure, and velocity in shock-heated oxygen flows, Applied Optics, vol. 32, Oct. 20, (1993), No. 30, Washington, US.

(*) Notice: Subject to any disclaimer, the term of this patent is extended or adjusted under 35 U.S.C. 154(b) by 57 days.

(Continued)

(21) Appl. No.: **10/894,309**

Primary Examiner—Edward Lefkowitz

Assistant Examiner—Andre Allen

(22) Filed: **Jul. 20, 2004**

(74) *Attorney, Agent, or Firm*—Antonelli, Terry, Stout and Kraus, LLP.

(65) **Prior Publication Data**

US 2005/0022603 A1 Feb. 3, 2005

(57) **ABSTRACT**

(51) **Int. Cl.**
G01N 21/61 (2006.01)

(52) **U.S. Cl.** **73/705; 356/437**

(58) **Field of Classification Search** **73/700, 73/705; 356/437**

See application file for complete search history.

A method of monitoring pressure of a gas species up to at most a predetermined maximum pressure value is disclosed. The method includes exposing the gas species to transmission of laser light, periodically modulating the wavelength of the laser light over a wavelength band including at least one absorption line of the gas species, optoelectrically converting the transmitted laser light, thereby generating an electric output signal, performing at least one of first filtering the electric output signal with a filter characteristic having a lower cut-off frequency not lower than a transition frequency and of second filtering the electric output signal with a bandpass filter characteristic having an upper cut-off frequency not higher than the transition frequency and a lower cut-off frequency above the modulation frequency of the periodic wavelength modulation. The output of at least one of the filterings is evaluated as a pressure indicative signal.

(56) **References Cited**

U.S. PATENT DOCUMENTS

- 4,123,160 A * 10/1978 Caputo et al. 356/301
- 4,492,469 A 1/1985 Fujimori
- 4,493,553 A 1/1985 Korb et al.
- 5,636,035 A * 6/1997 Whittaker et al. 356/437
- 5,637,872 A * 6/1997 Tulip 250/338.5
- 5,640,245 A * 6/1997 Zybin et al. 356/437
- 6,356,350 B1 3/2002 Silver et al.
- 6,639,678 B1 10/2003 Veale

72 Claims, 24 Drawing Sheets

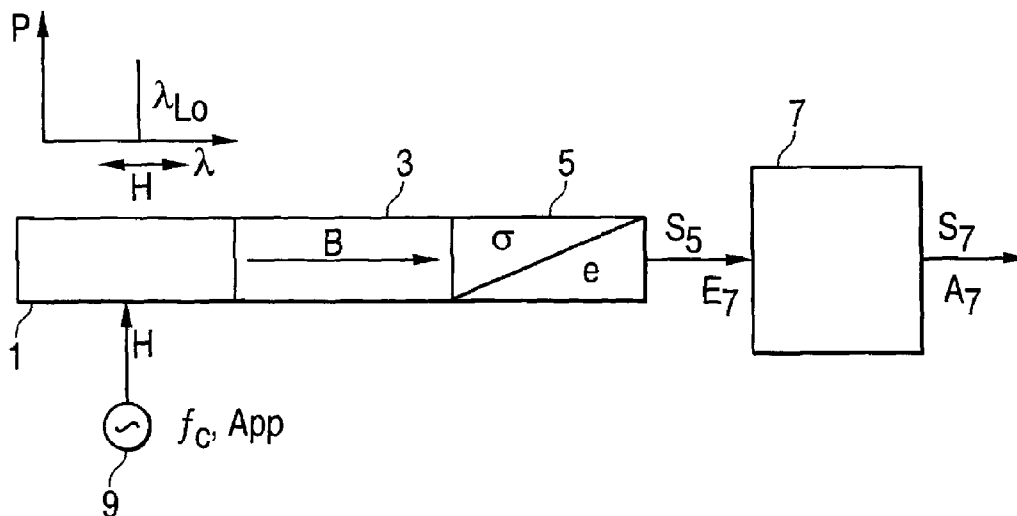

U.S. PATENT DOCUMENTS

2001/0015408 A1 8/2001 Stock
2005/0022603 A1 2/2005 Lehmann et al.

FOREIGN PATENT DOCUMENTS

FR 2 735 236 12/1996

WO WO 2005/040753 A2 5/2005

OTHER PUBLICATIONS

Hans P. Zappe, et al. ; Narrow-linewidth vertical-cavity surface-emitting lasers for oxygen detection; May 20, 2000; pp. 2475-2479. International Search Report; International Application No. PCT/CH2006/000289; mailed Aug. 1, 2006.

* cited by examiner

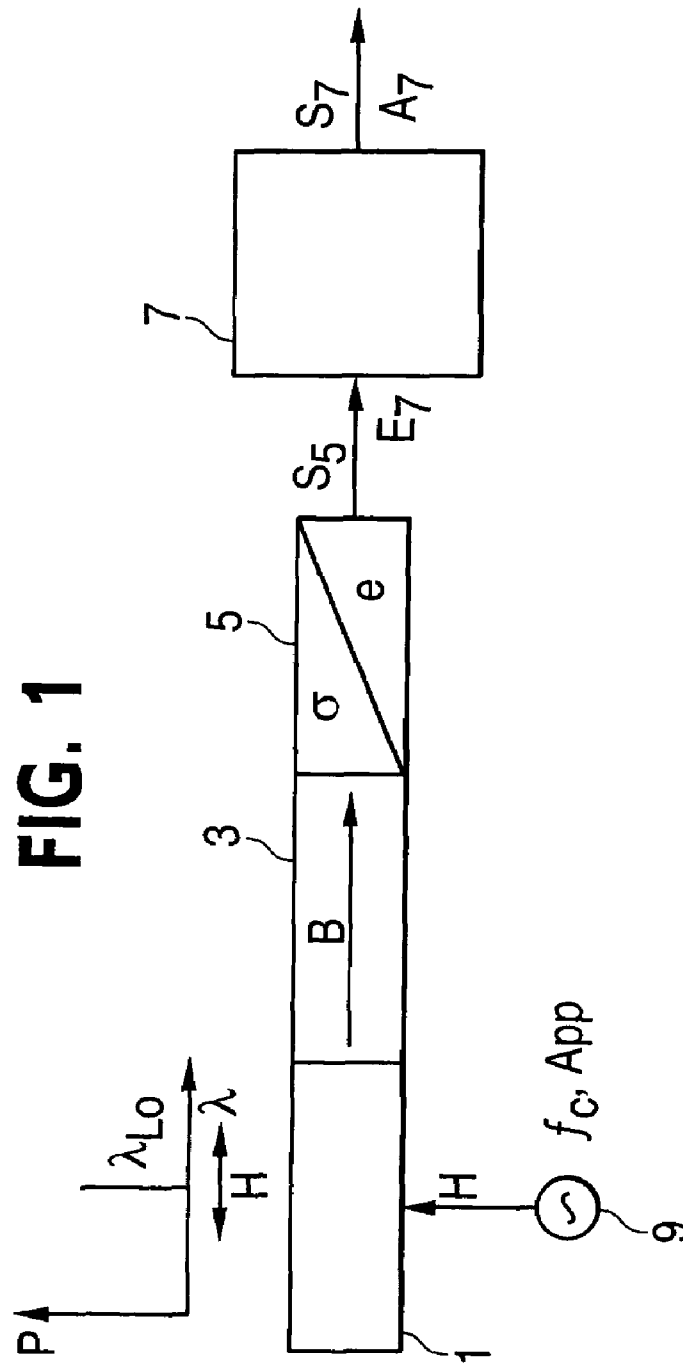

FIG. 2



FIG. 3

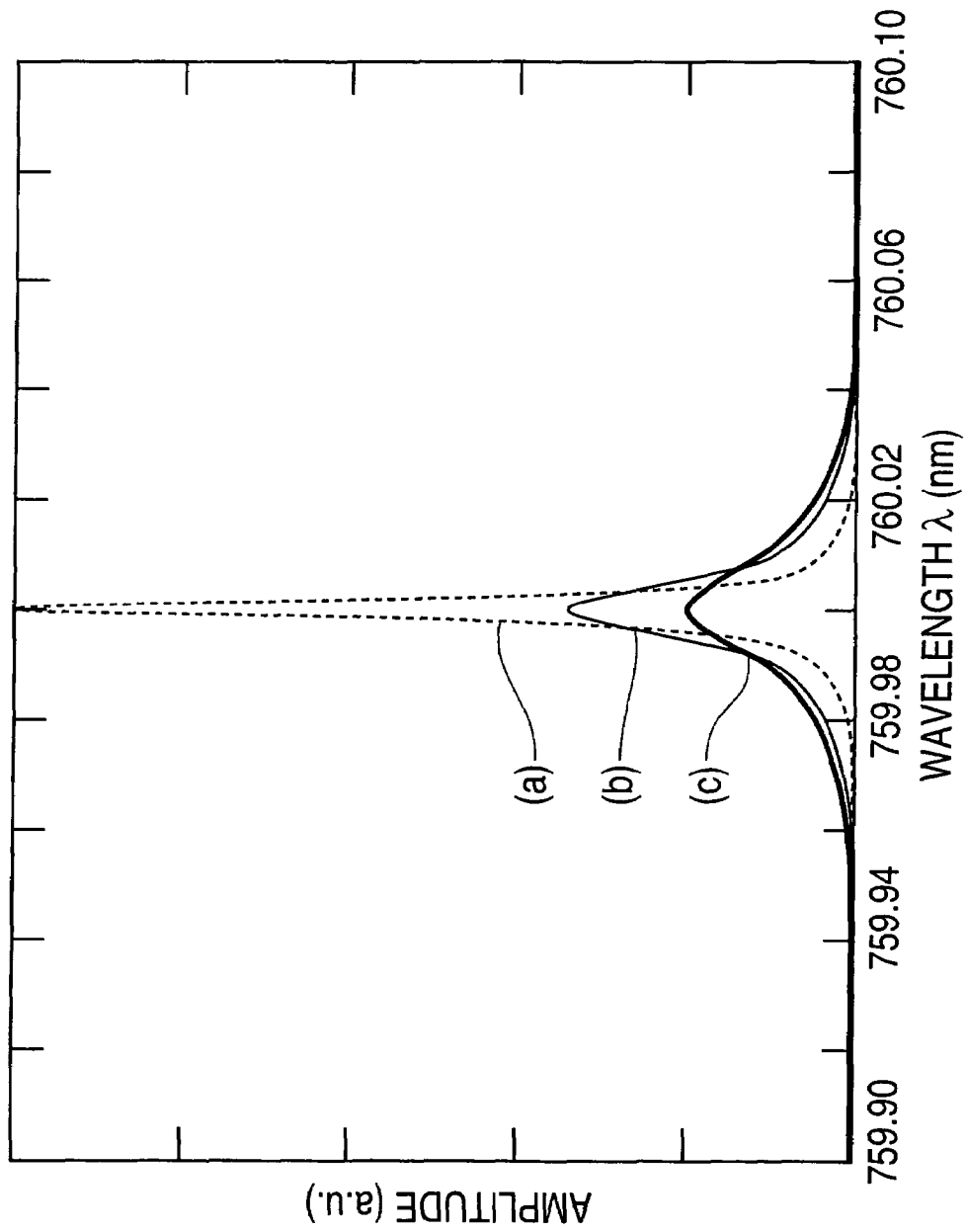

FIG. 4

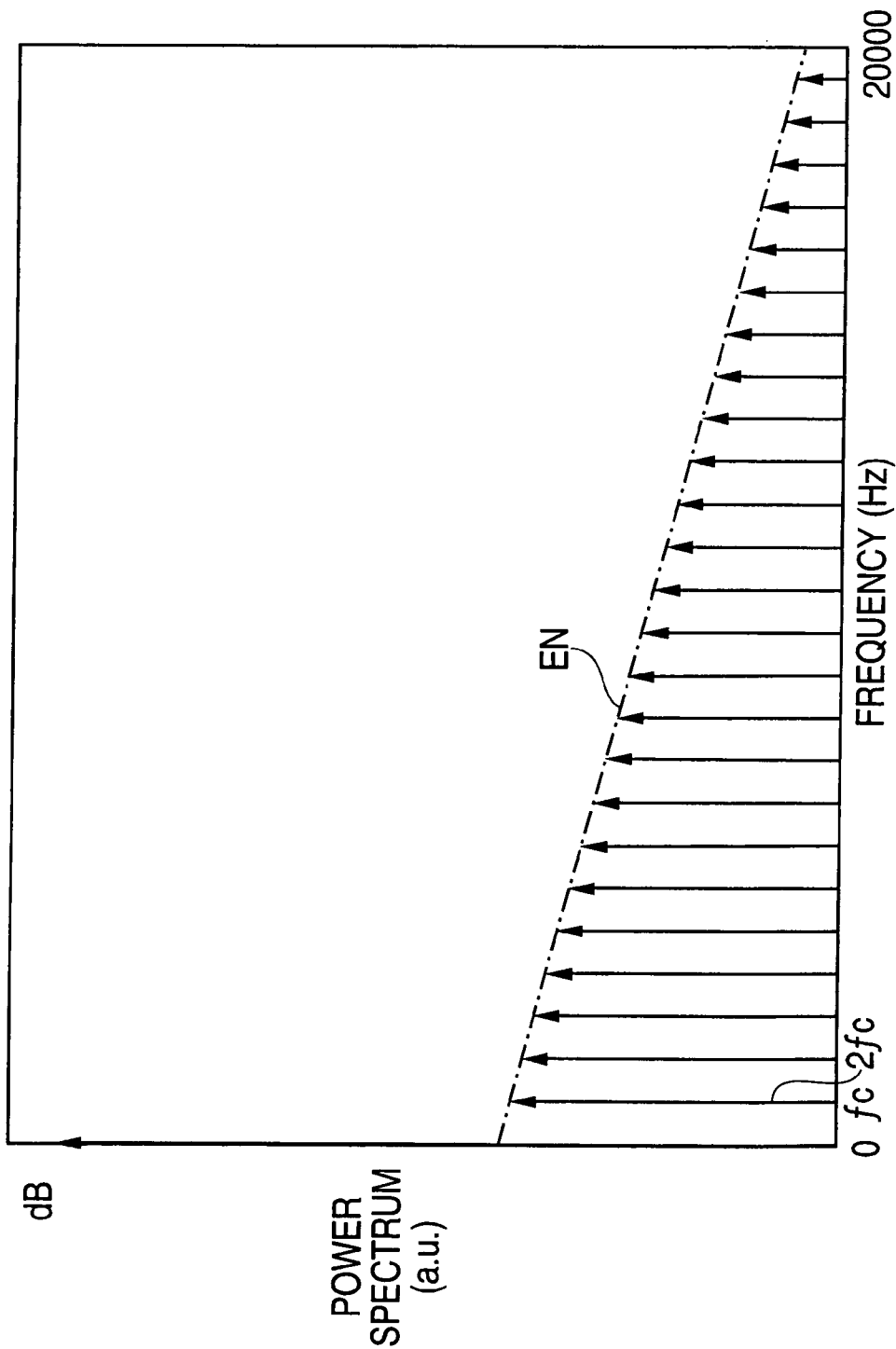

FIG. 5

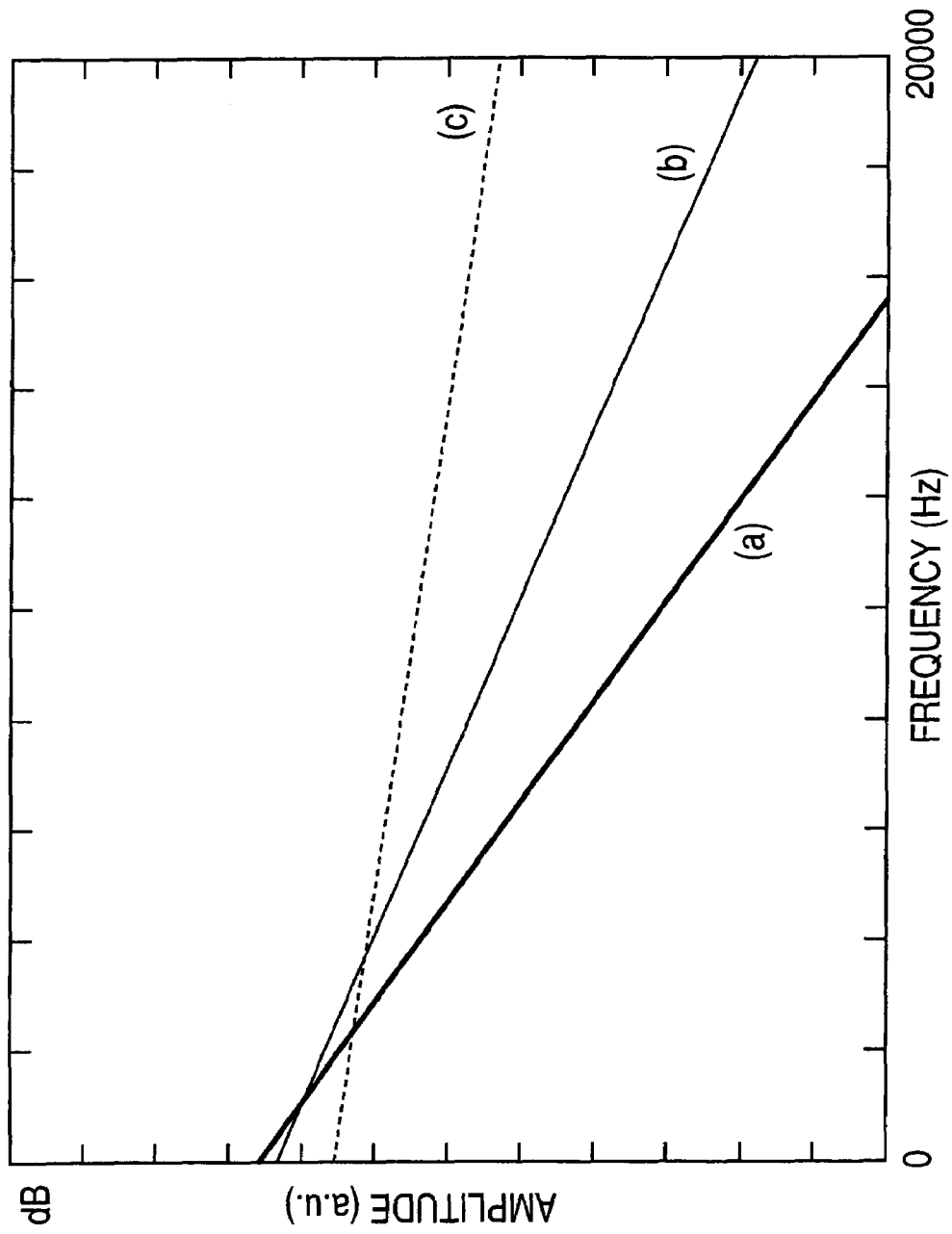

FIG. 6

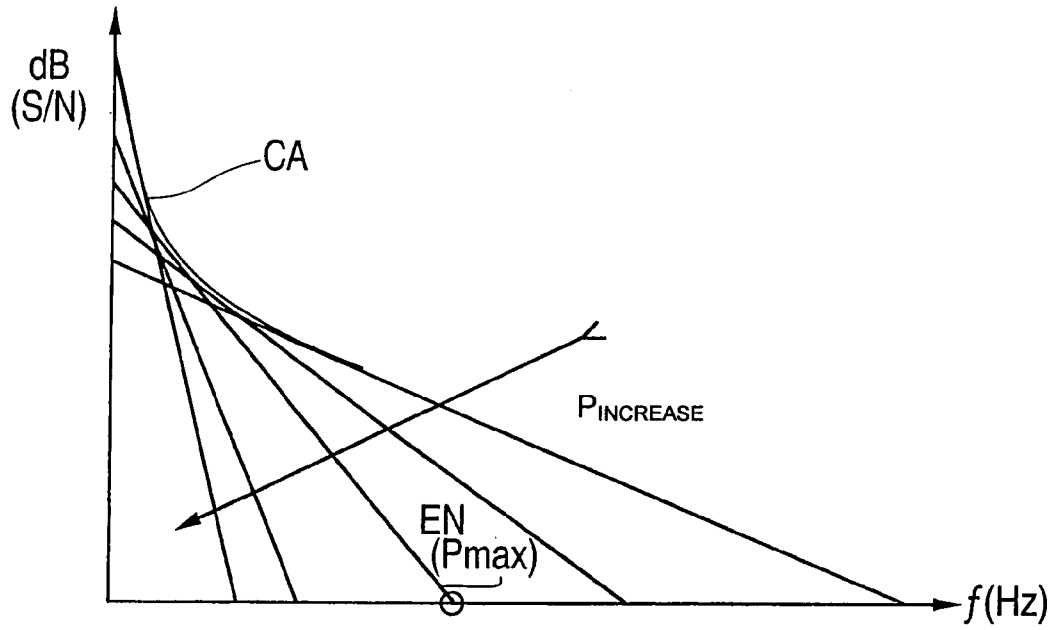

FIG. 7

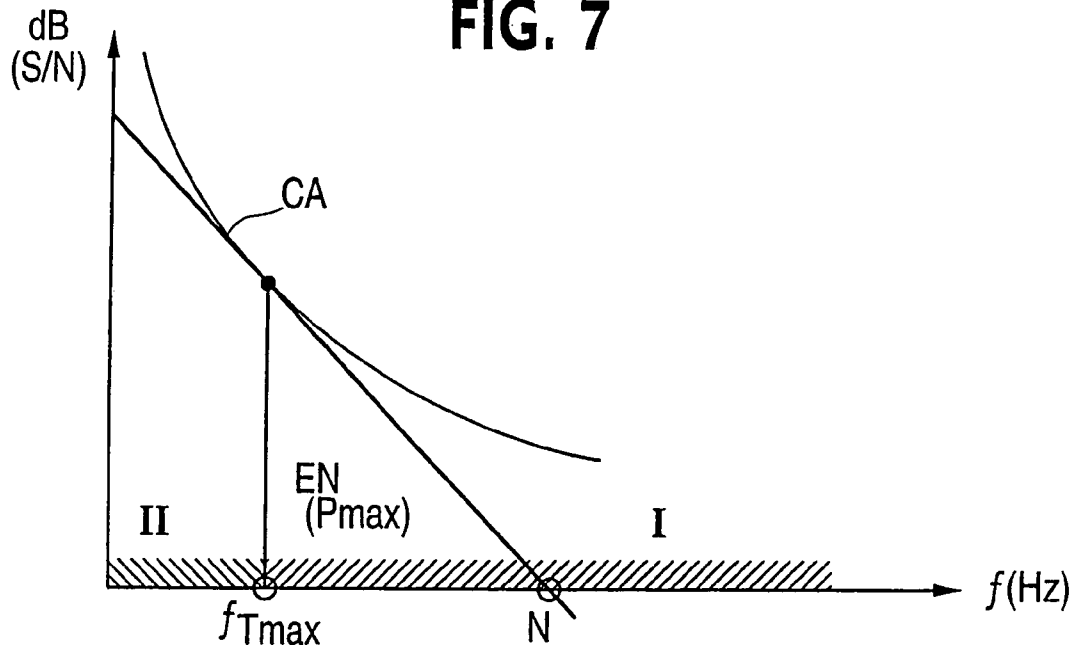

FIG. 8

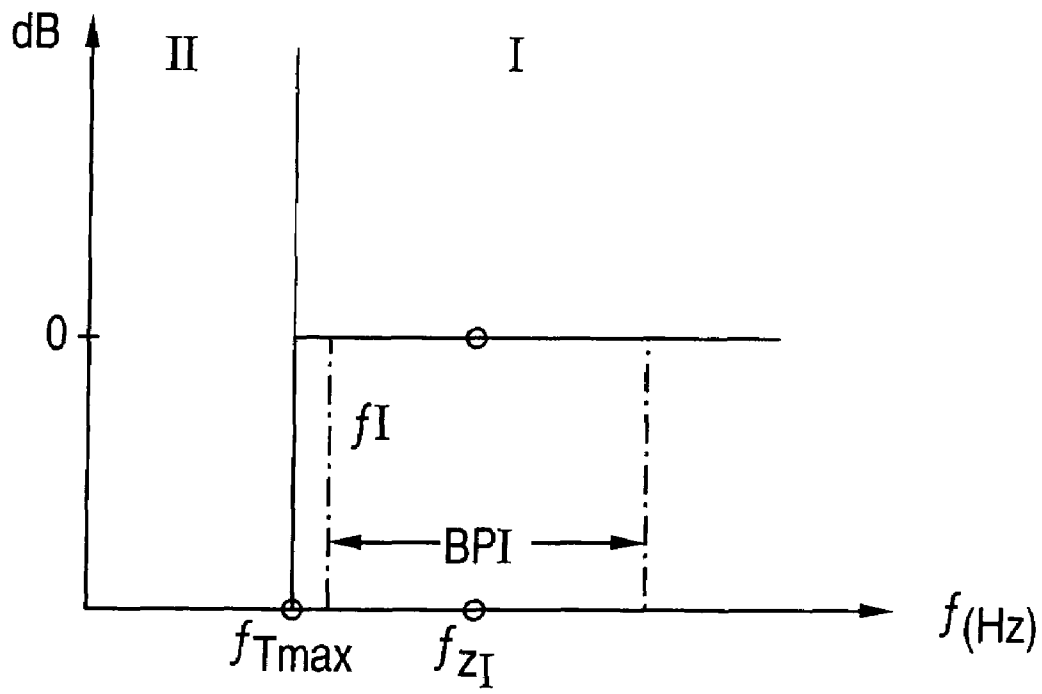

FIG. 9

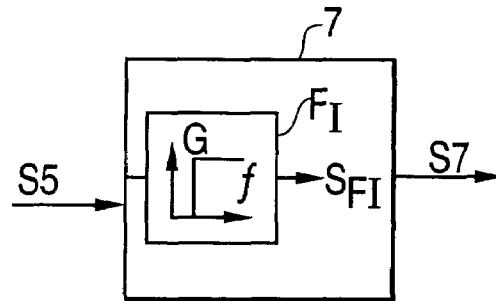

FIG. 10

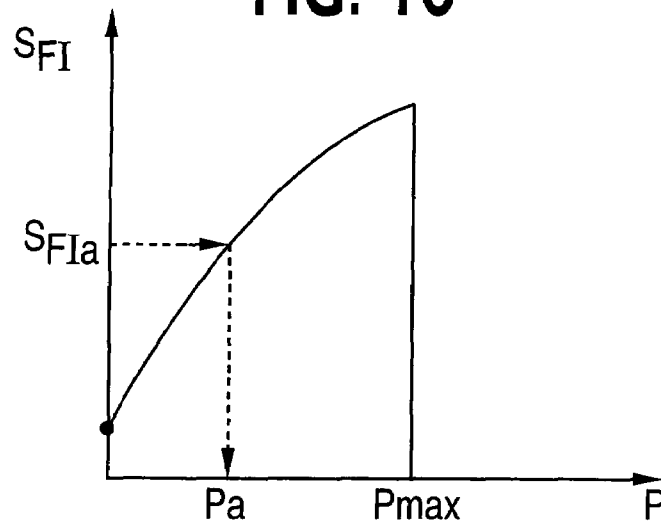

FIG. 11

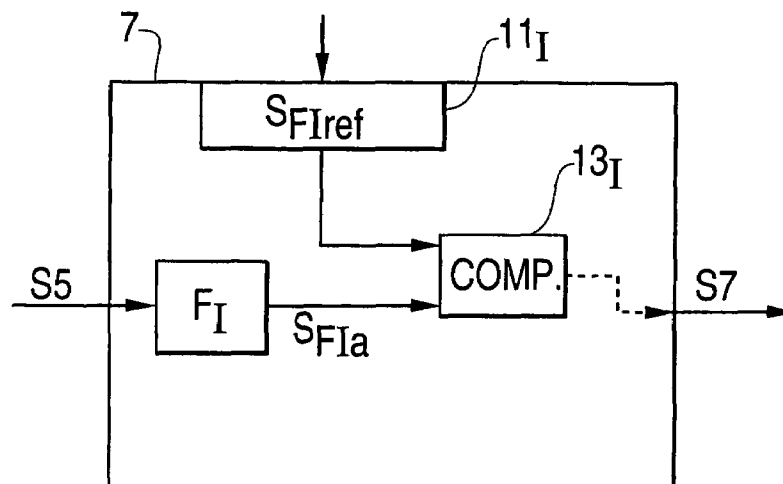

FIG. 12

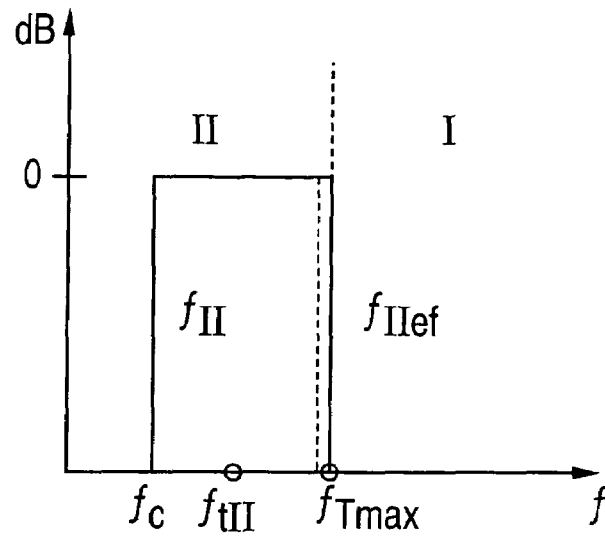

FIG. 13

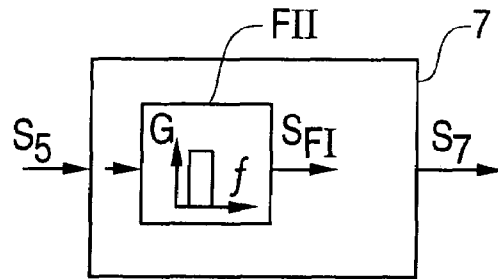

FIG. 14

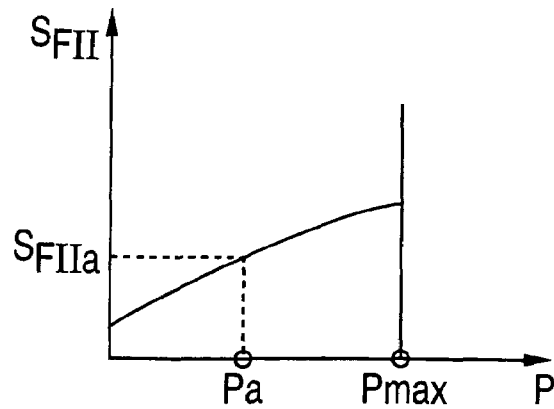

FIG. 15

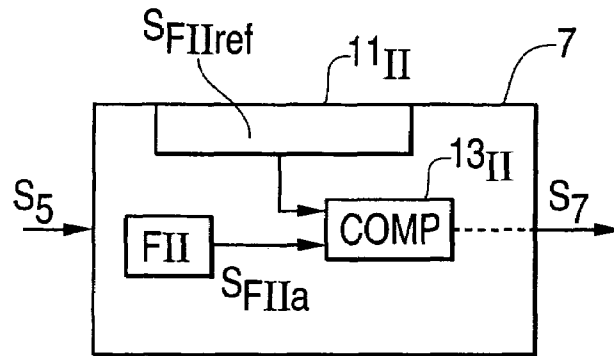

FIG. 16

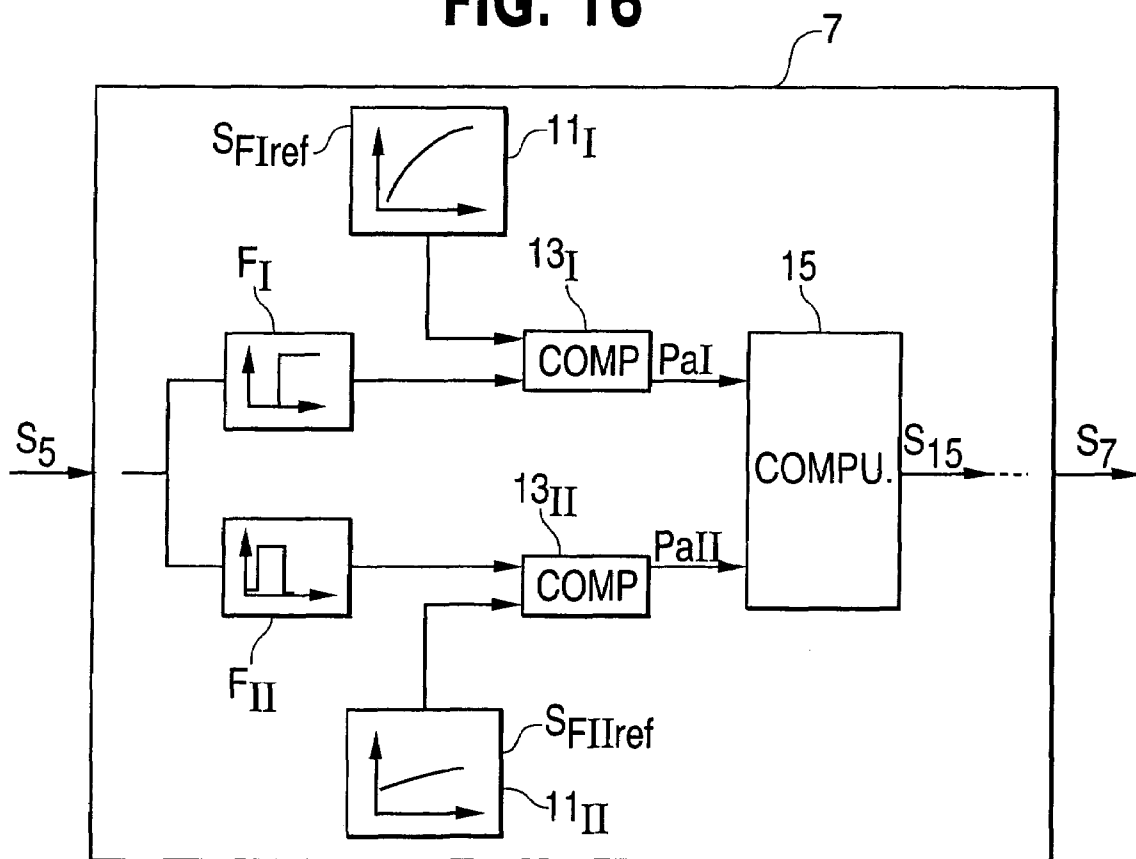

FIG. 17

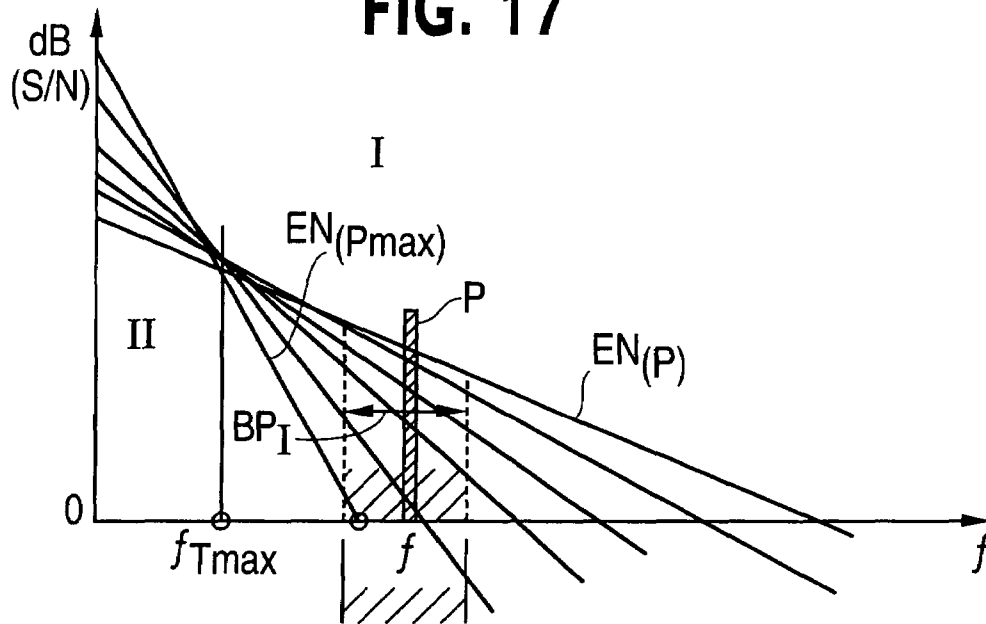

FIG. 18

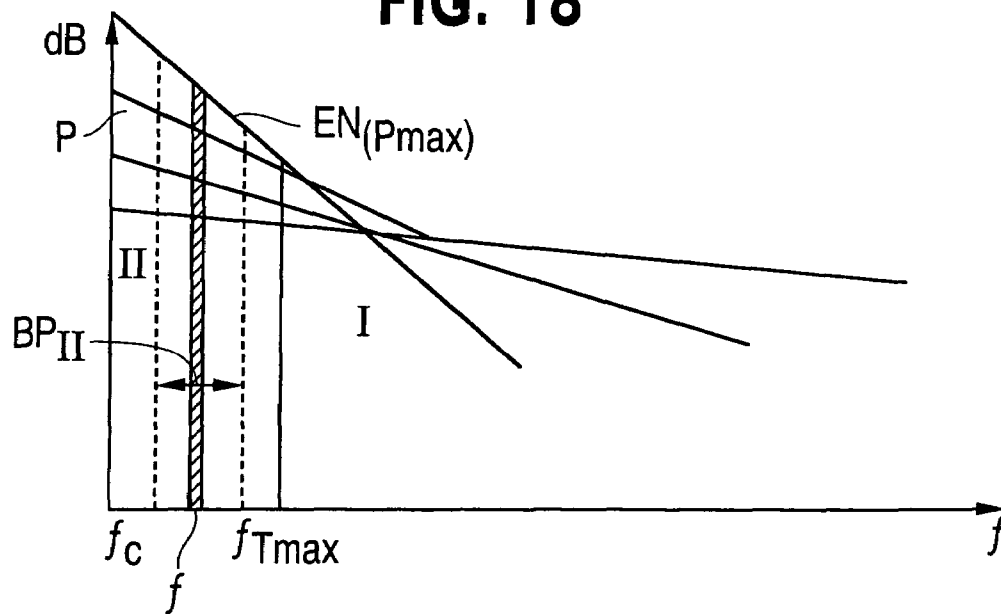

FIG. 19

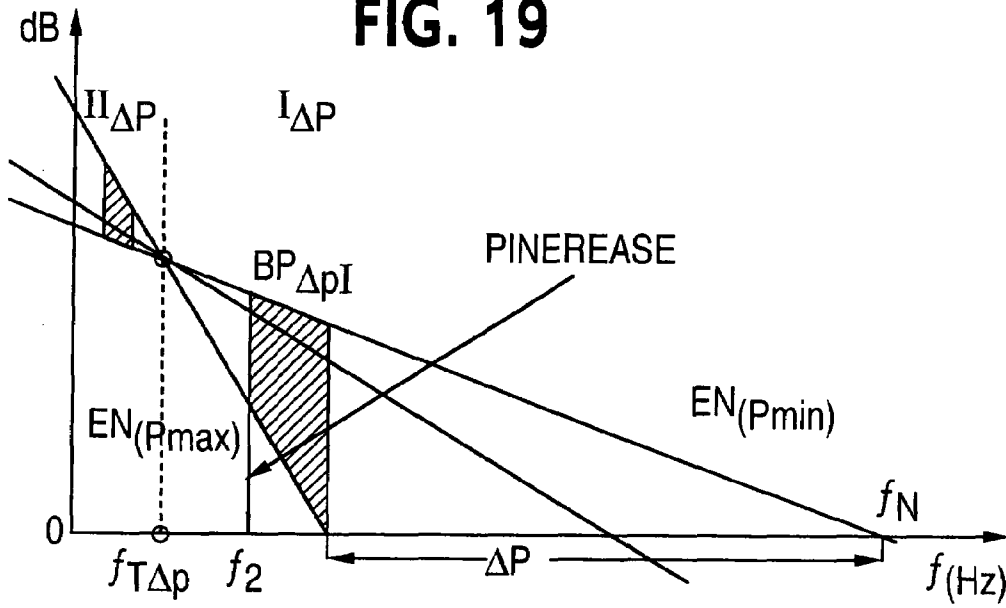

FIG. 20

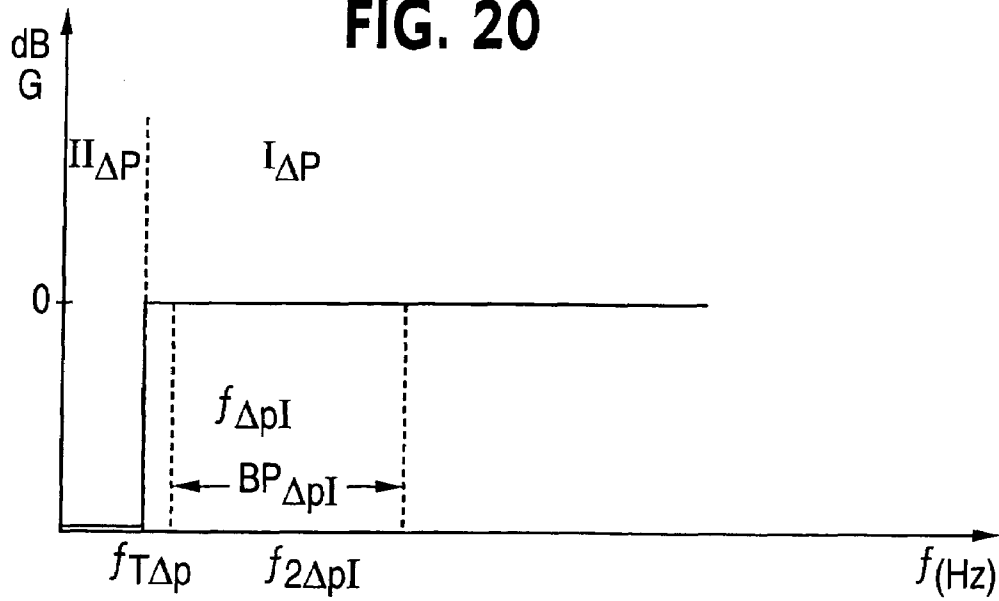

FIG. 21

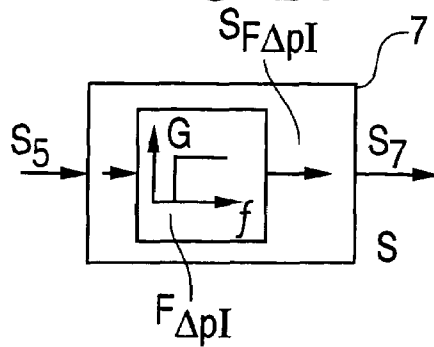

FIG. 22

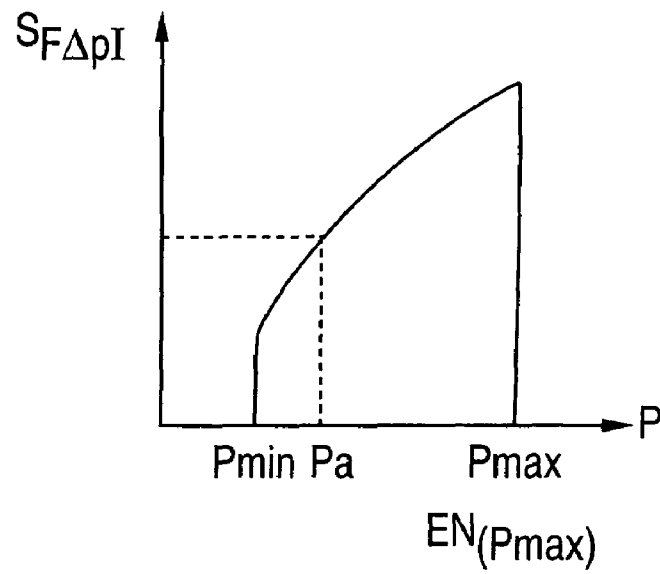

FIG. 23

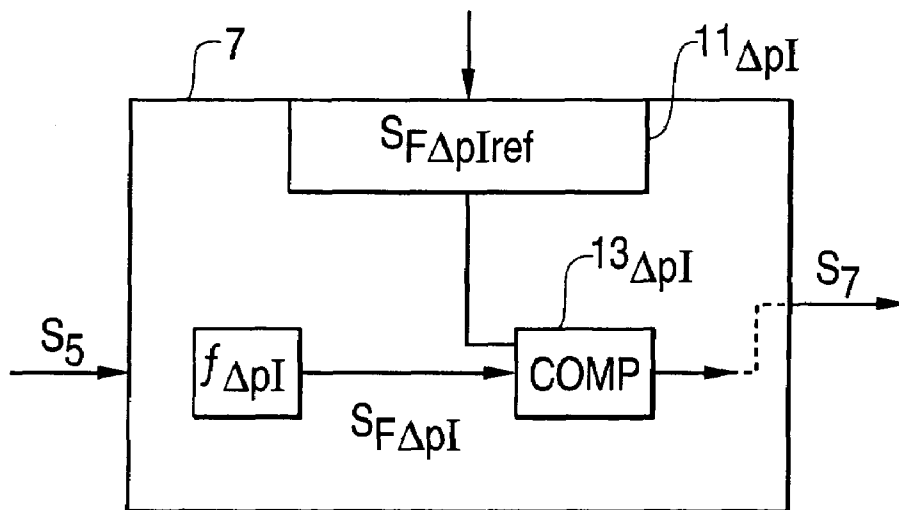

FIG. 24

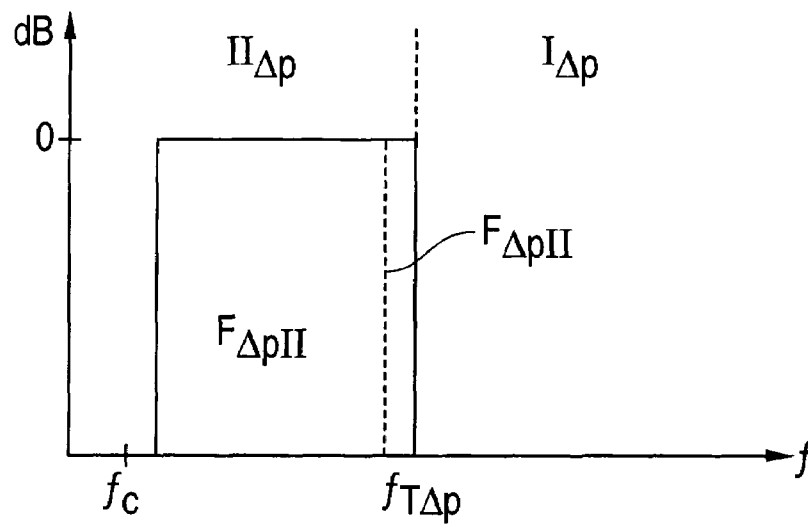

FIG. 25

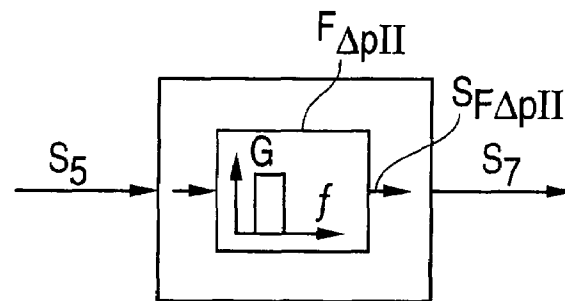

FIG. 26

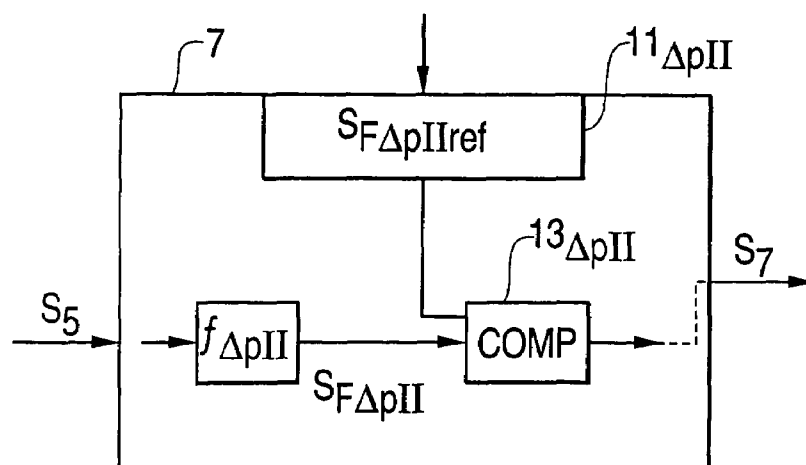

FIG. 27

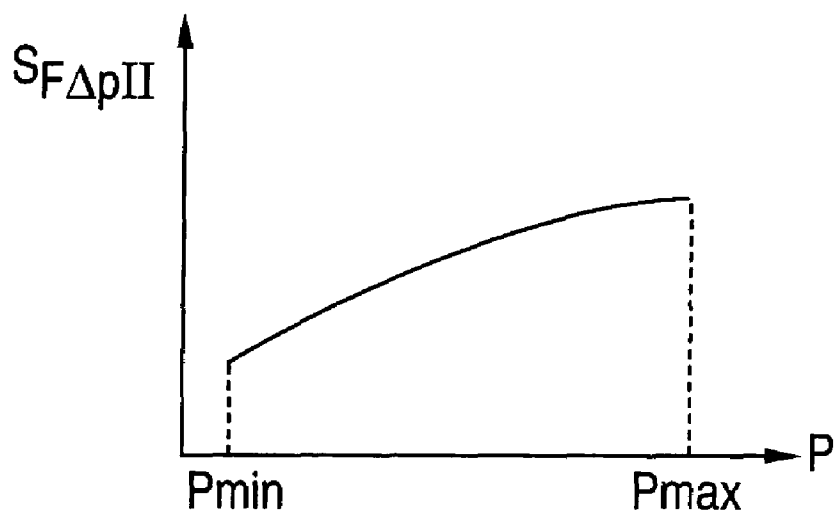

FIG. 28

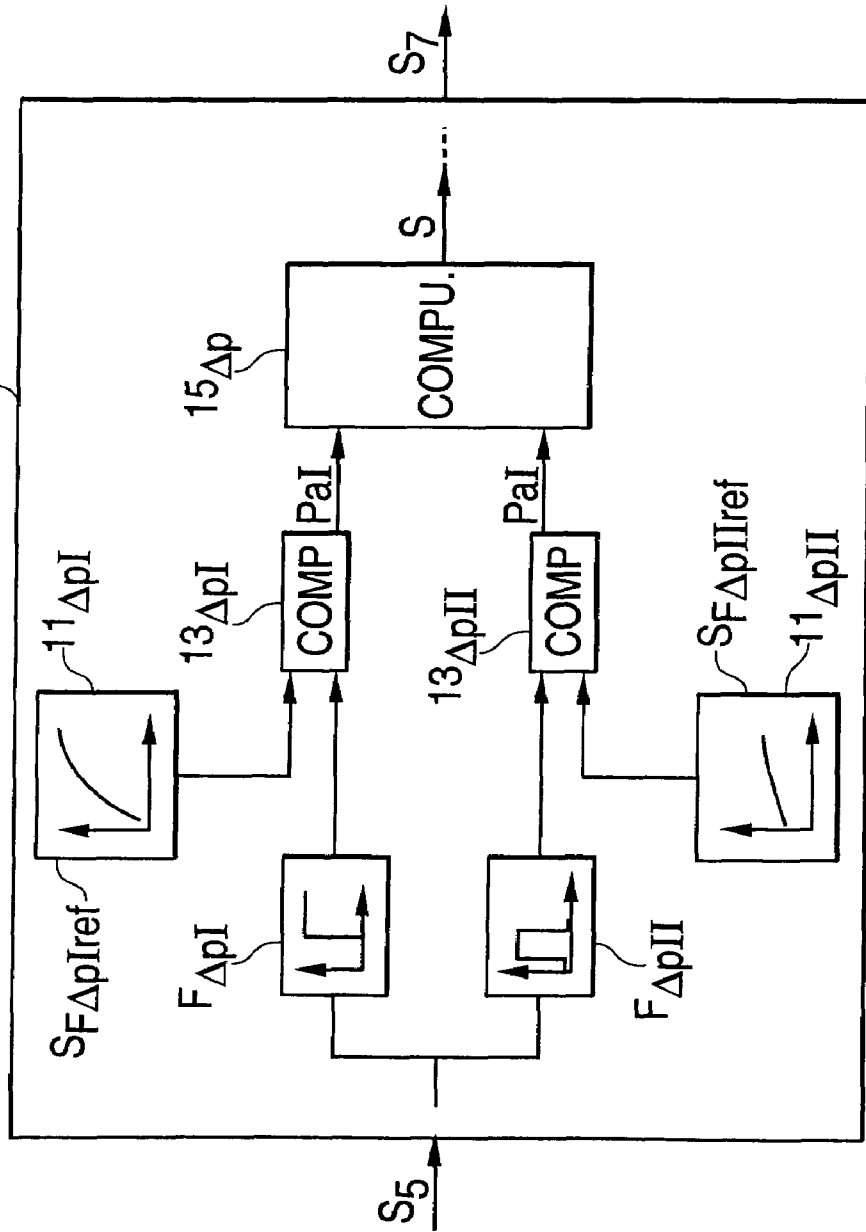

FIG. 29

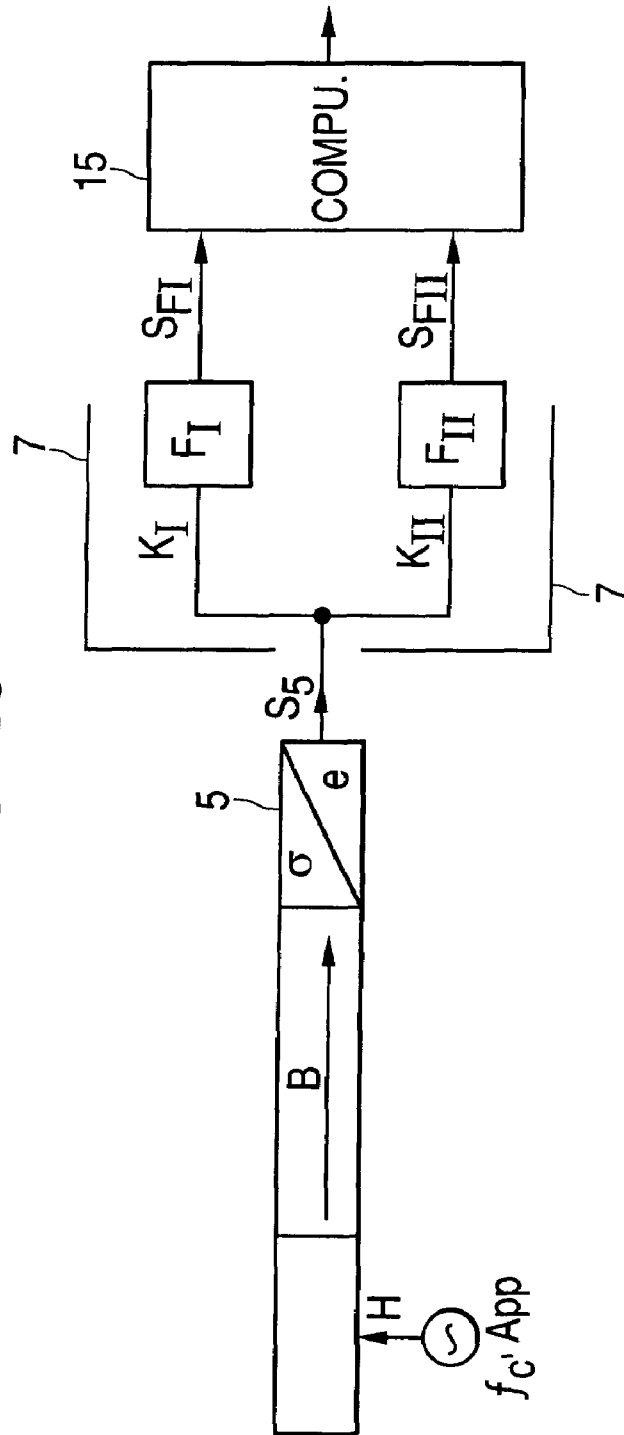

FIG. 30

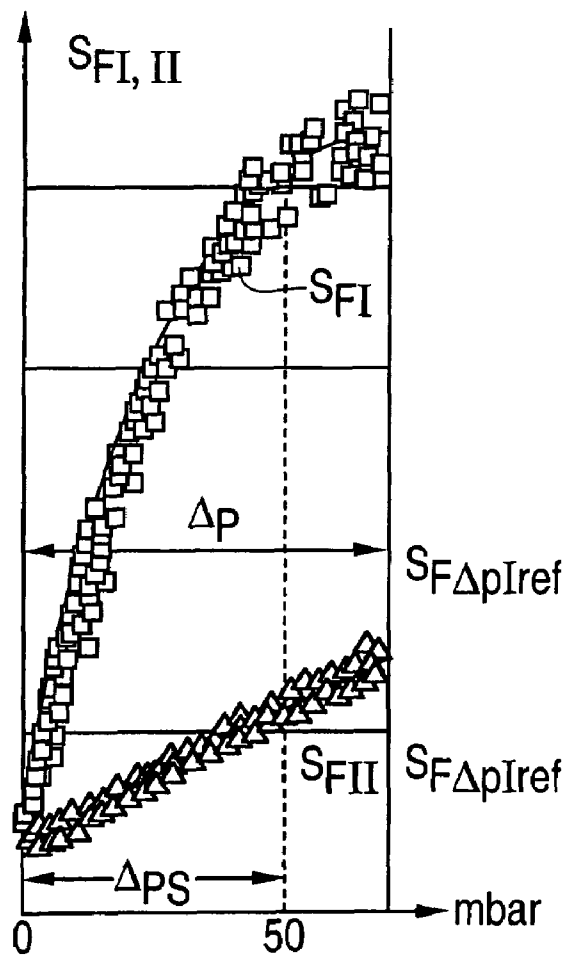

FIG. 31

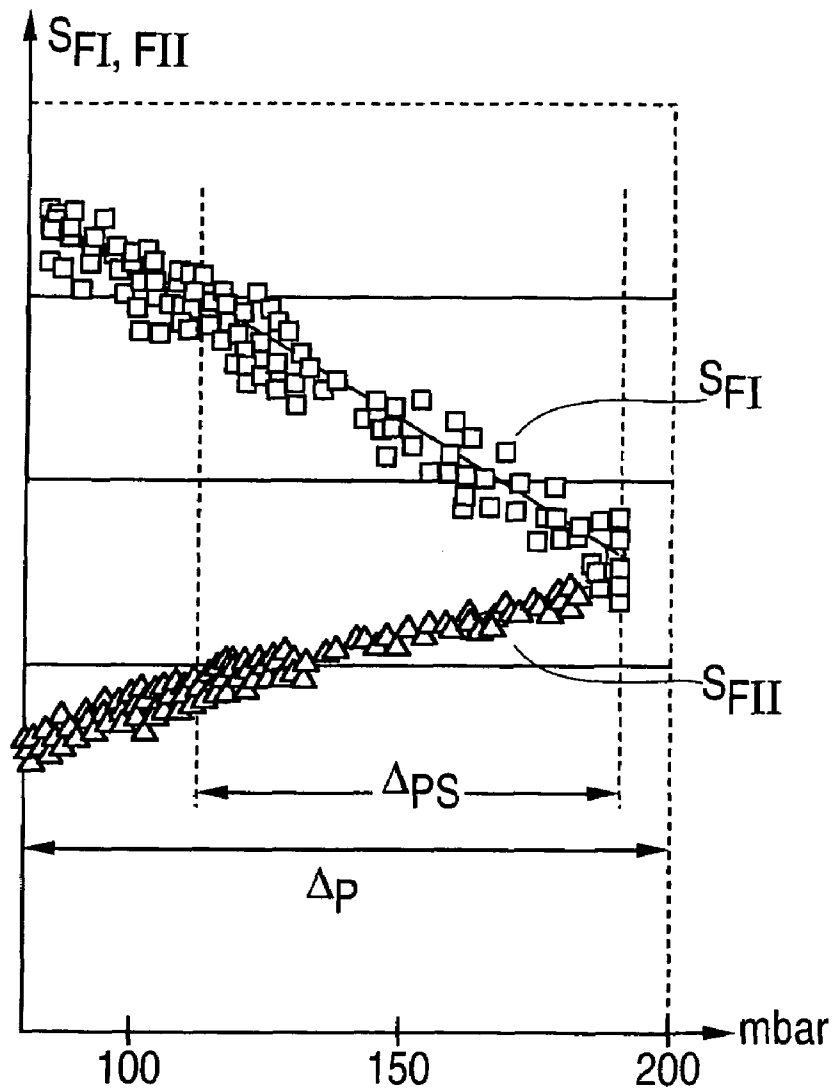

FIG. 32

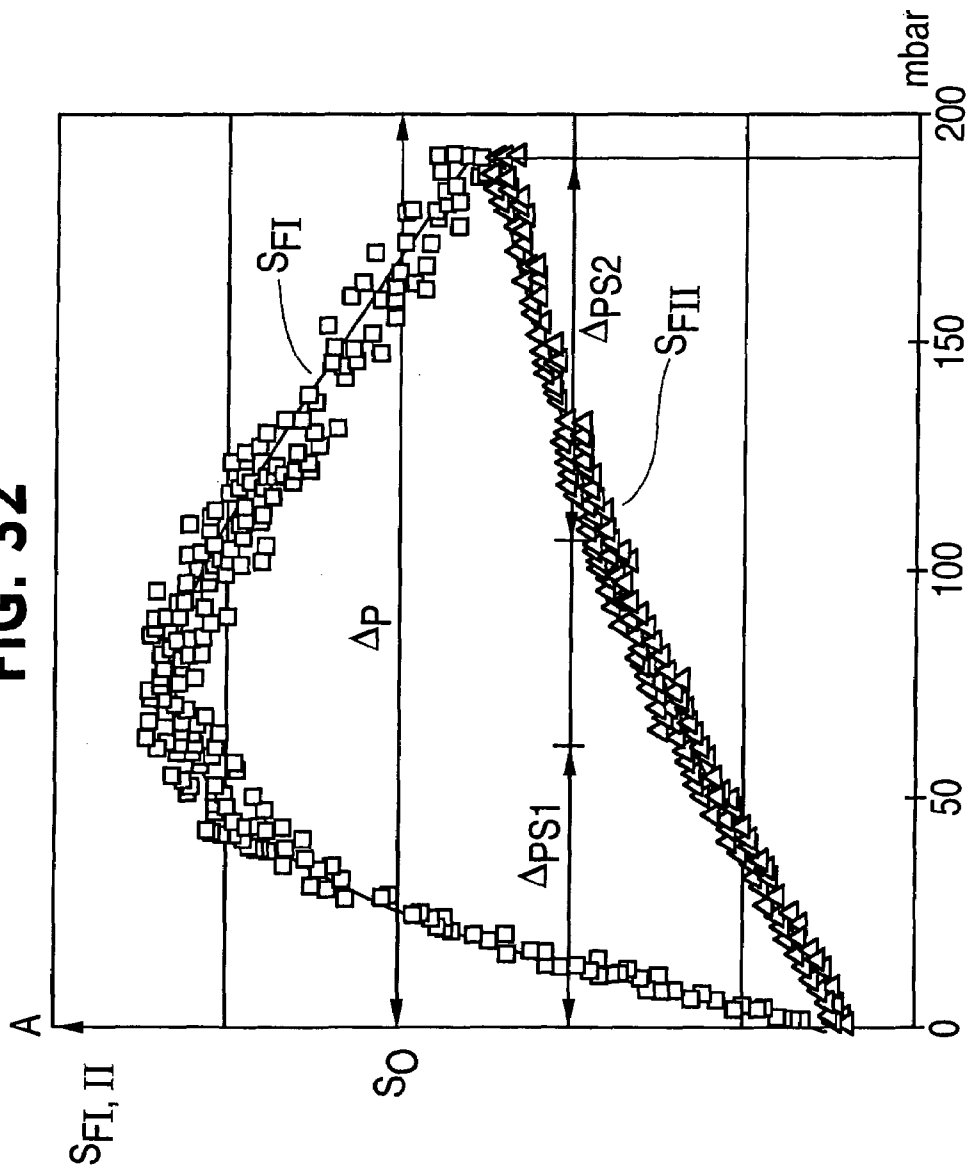

FIG. 33

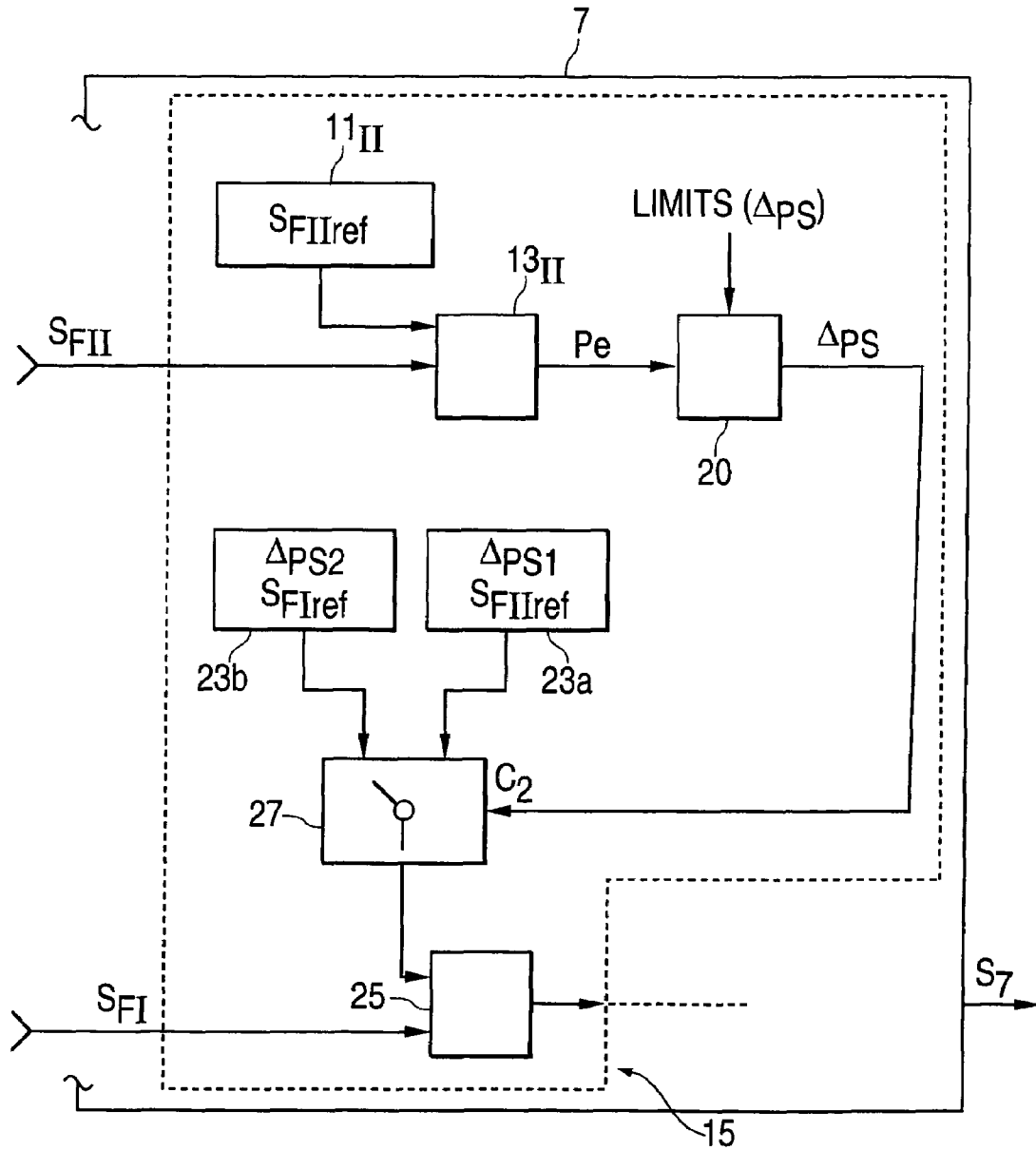

FIG. 34

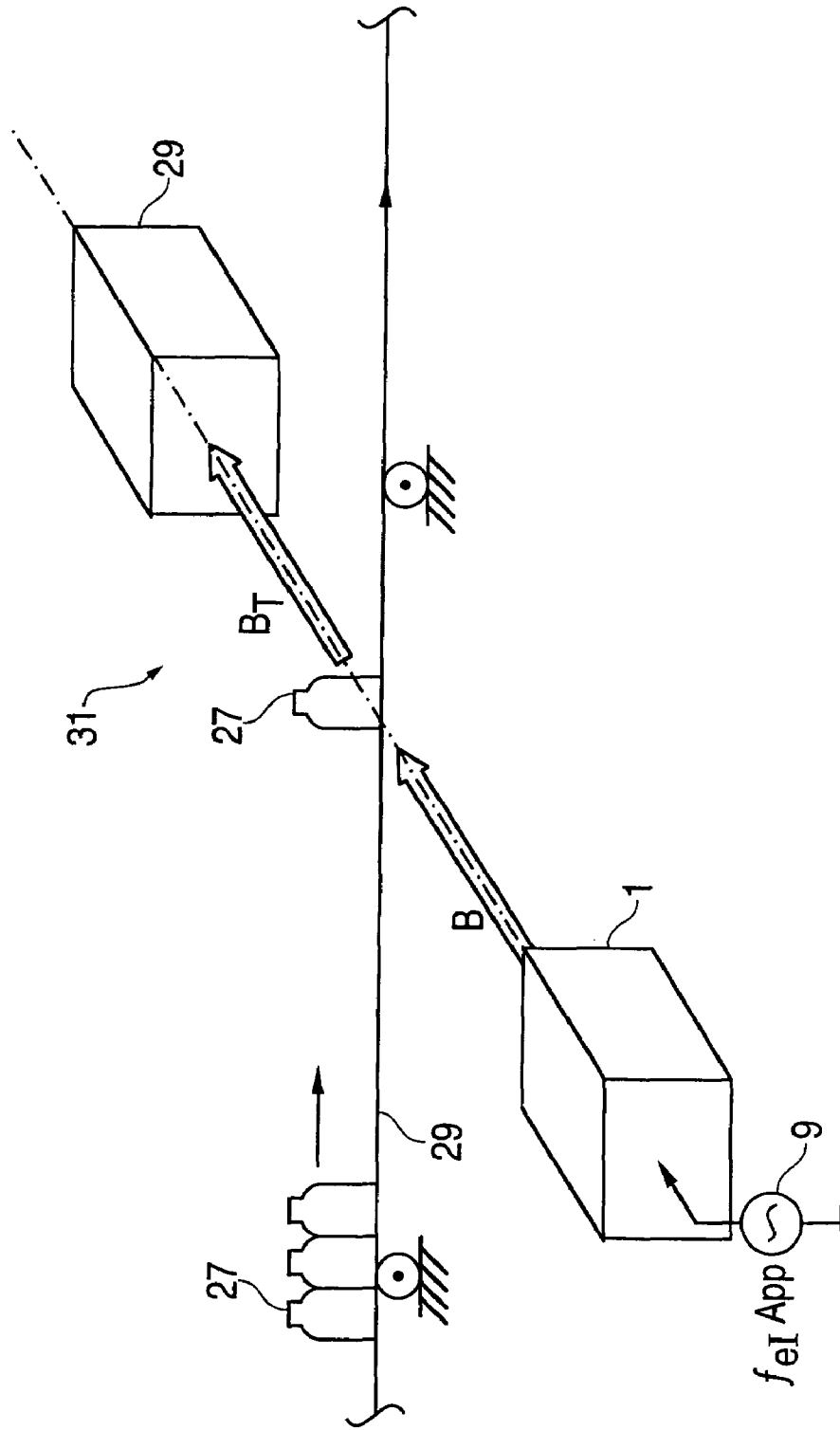
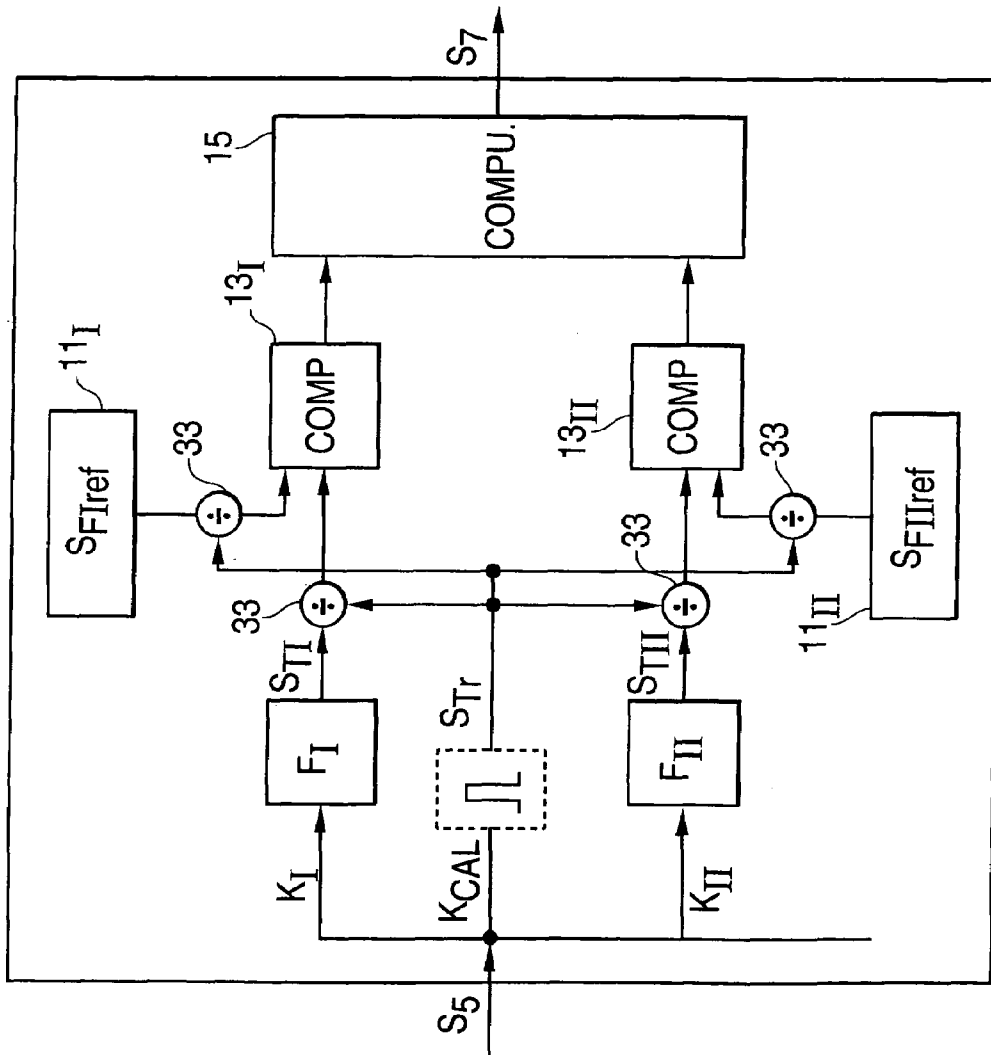

FIG. 35



**METHOD OF MONITORING PRESSURE OF
A GAS SPECIES AND APPARATUS TO DO
SO**

The present invention is directed on a novel method and apparatus and on various embodiments thereof for monitoring pressure of a gas species. It resulted from the need of rapidly monitoring oxygen content in transparent closed containers, as of glass or plastic material vials, e.g. for medical appliances.

Under a first aspect a first embodiment of the method according to the present invention of monitoring of a gas species up to at most a predetermined maximum pressure value, such method comprises

exposing the gas species to transmission of laser light; periodically modulating the wavelength of the laser light over a wavelength band which includes at least one absorption line of the gas species;

optoelectrically converting the transmitted laser light, thereby generating an electric output and it further comprises at least one of

first filtering the electric output signal of converting with a filter characteristic which has a lower cut-off frequency which is not lower than a transition frequency and of

second filtering the electric output signal of the conversion with a band pass filter characteristic which has an upper cut-off frequency which is not higher than the transition frequency and with a lower cut-off frequency above modulation frequency of the periodic wavelength modulation.

Thereby, the transition frequency in the spectrum of the electric output signal of conversion is determined there where the caustic function of the pressure-dependent spectrum envelopes of the addressed output electric signal touches the envelope of the spectrum at the maximum pressure.

The output of the addressed at least one filtering is evaluated as a pressure indicative signal.

In one embodiment both, namely first and second filtering, are performed.

In one embodiment the first filtering is performed as band pass filtering.

In one embodiment the first filtering is performed with a lower cut-off frequency which is higher than the addressed transition frequency.

In another embodiment the first filtering is performed as band pass filtering and there is determined a filter frequency above the lower cut-off frequency of the addressed first filtering there where the derivatives of spectral amplitude vs. pressure of the electric output signal of the conversion at least approximately accord with a desired characteristic. Then band pass first filtering is performed with the determined filter frequency as band pass center frequency.

In a further embodiment the first filtering is performed as band pass filtering and bandwidth of this band pass filtering is selected with the target of achieving a desired signal to noise ratio.

Still in a further embodiment the first filtering is performed as a band pass filtering and a desired sensitivity of the output signal of the band pass first filtering is realized under consideration of noise in that the followings steps are performed once or more than one time in a looping manner:

(a) A filter frequency is determined above the lower cut-off frequency of the first filtering there where the derivative of spectral amplitude vs. pressure of the electric output signal of conversion at least approximately accords with

a desired characteristic. Band pass center frequency of the addressed band pass first filtering is established at the filter frequency thus determined.

(b) The bandwidth of the band pass first filtering is designed for a desired signal to noise ratio.

In a further embodiment the method according to the present invention comprises selecting the upper cut-off frequency of the second filtering below the addressed transition frequency.

Still in a further embodiment of the method according to the present invention the second filtering is performed with a center frequency there where the derivative of spectral amplitude vs. pressure of the electric output signal at least approximately accords with a desired characteristic.

Still in a further embodiment the second filtering is performed with a bandwidth selected for a desired signal to noise ratio.

In a further embodiment the second filtering is performed, thereby realizing a desired sensitivity of an output signal of the addressed second filtering under consideration of noise by performing the following steps subsequently once or in a looping manner more than one time:

(a) Determining a center frequency of the second filtering there where the derivative of spectral amplitude vs. pressure of the electric output signal of conversion at least approximately accords with a desired characteristic and

(b) tailoring bandwidth of the second filtering for a desired signal to noise ratio.

Under a second aspect of the present invention there is established the method of monitoring pressure of a gas species within a predetermined pressure range, namely between a maximum pressure value and a minimum pressure value. This latter method comprises

exposing the gas species to transmission of laser light; periodically modulating the wavelength of the laser light over a wavelength band which includes at least one absorption line of the gas species;

optoelectrically converting the transmitted laser light, thereby generating an electric output signal;

then at least one of the following steps is performed

first filtering of the electric output signal of conversion with a filter characteristic which has a lower cut-off frequency not lower than a transition frequency and

second filtering of the electric output signal of conversion with a band pass filter characteristic which has an upper cut-off frequency which is not higher than the transition frequency and with a lower cut-off frequency which is above modulation frequency of the periodic wavelength modulation.

Thereby, the addressed transition frequency in this case is determined in the spectrum of the electric output signal there where the spectrum envelopes of the electric output signal at the minimum and at the maximum pressure values intersect.

Then the output signal of at least one of the addressed first and second filtering is evaluated as a pressure indicative signal.

In one embodiment both the first and second filtering is performed under the second aspect.

In a further embodiment under the second aspect the first filtering is performed as band pass filtering.

Under another mode of the second aspect of the present invention the first filtering is performed with a lower cut-off frequency which is higher than the transition frequency.

Under the second aspect another embodiment comprises performing the first filtering as band pass filtering between

the transition frequency and a noise limit frequency. The noise limit frequency is thereby defined there where noise energy of the electric output signal of conversion equals signal energy of that electric output signal at the predetermined minimum pressure value.

A further embodiment under the second aspect comprises selecting the band pass first filtering so that the energy difference in the filtered spectrum of the electric output signal between the maximum pressure applied and the minimum pressure applied becomes maximal.

Still a further embodiment under this second aspect comprises selecting band pass first filtering under the constraint that noise energy of the electric output signal, there where the filtering is effective, becomes at most equal to signal energy at the predetermined maximum pressure value.

Still in a further embodiment under this second aspect the upper cut-off frequency of the second filtering is selected below the transition frequency.

Still another embodiment under this second aspect comprises performing the second filtering there where the energy difference in the spectrum of the electric output signal of conversion is maximum between applying the maximum pressure value and the minimum pressure value which both establish for the pressure range to be monitored under this second aspect of the invention.

Under a third aspect the present invention provides for a method for monitoring pressure of a gas species which comprises

- exposing the gas species to transmission of laser light;
- periodically modulating the wavelength of the laser light over a wavelength band which includes at least one absorption line of the gas species;
- optoelectrically converting the transmitted laser light, thereby generating an electric output signal;
- inputting a signal which is dependent on the electric output signal of conversion to at least a first and a second parallel gas pressure monitoring channel;
- performing in the first channel first filtering and in the second channel second filtering;
- performing the first filtering so that the output signal thereof varies with a first characteristic as a function of pressure of said gas species;
- performing the second filtering so that the output signal thereof varies with a second characteristic as a function of the addressed gas pressure;
- further performing said first and second filtering so that the first characteristic becomes different from the second characteristic.

From combining signals which are dependent on the output signals of the first and of the second filtering a pressure indicative signal is evaluated.

In an embodiment of this third aspect at least one of the first and of the second filtering is performed as band pass filtering.

In an embodiment under this third aspect first and second filtering is performed in non-overlapping frequency areas of the spectrum of the electric output signal.

In a further embodiment under this third aspect the first and the second filtering are performed as band pass filtering.

In a further embodiment under the third aspect of the present invention the first and second filtering are performed in respective first and second frequency ranges, whereby the energy of the electric output signal has a first energy vs. pressure characteristic in the first frequency range and has a second energy vs. pressure characteristic in the second

frequency range, whereby the first and second energy characteristics are different from each others.

In a further embodiment which is applicable to the present invention under all its aspects there is prestored a first reference characteristic which represents the first characteristic and/or there is prestored a second reference characteristic which represents the second characteristic. The addressed characteristics are the characteristics with which the output signal of the respective filtering varies as a function of pressure of the gas species to be monitored.

Then momentary signals which depend from signals of the first and/or second filterings respectively are compared with a stored first and second reference characteristic, whereby first and second pressure indicative signals are generated. Thus, momentarily prevailing filtering results become compared with predetermined signal vs. pressure characteristics to establish from the prevailing signals to which pressure value they accord.

Still in another embodiment under the third aspect of the present invention, but also applicable to the invention under the first and second aspects, the first filtering generates a first output signal which has first derivatives vs. pressure within a predetermined pressure range. The second filtering generates a second output signal which has second derivatives vs. pressure in the addressed predetermined pressure range. Thereby, absolute values of one of the addressed first and second derivatives are smaller than absolute values of the other of the addressed derivatives in at least one common subpressure range of the predetermined pressure range. Thereby, when speaking of signal derivatives we clearly disregard signal noise which makes derivative values random.

In a further embodiment under the third aspect but also applicable to the invention under the first and second aspects the second filtering generates a second output signal which has exclusively positive or negative derivatives vs. pressure in a predetermined pressure range.

The first filtering generates a first output signal with first derivatives vs. pressure which are exclusively positive in at least one pressure subrange of the predetermined pressure range and which are exclusively negative in at least one second subrange of the addressed predetermined pressure range. Thereby, the absolute values of the second derivatives are smaller in at least one of the addressed pressure subranges than the absolute values of the first derivatives also considered in the addressed at least one of the subranges and again without considering noise.

In an embodiment especially under the third aspect of the present invention from a signal dependent on the second output signal of second filtering one of the pressure subranges is determined.

In a further embodiment from this pressure subrange determined and from the first output signal, i.e. of first filtering, a pressure indicative signal is determined.

Under the third aspect of the present invention a further embodiment comprises

- predetermining a maximum pressure to be monitored;
- performing at least one of the following steps, namely
 - performing the second filtering with a band pass filter characteristic which has an upper cut-off frequency not higher than a transition frequency and which has a lower cut-off frequency which is above modulation frequency of periodic wavelength modulation and
 - performing first filtering with a filter characteristic which has a lower cut-off frequency which is not lower than the transition frequency.

5

Thereby, the addressed transition frequency is determined in the spectrum of the electric output signal there where the caustic function of the pressure-dependent spectrum envelopes of the electric output signal touches the envelope of the spectrum at the maximum pressure.

Thereby, in one embodiment first as well as second filtering are performed.

Thereby, in a further embodiment first filtering is performed as band pass filtering.

Thereby, in a further embodiment first filtering is performed with a lower cut-off frequency higher than the transition frequency.

Thereby, in another embodiment first filtering is performed as a band pass filtering and there is determined a filter frequency which is above the lower cut-off frequency of first filtering there where the derivative of spectral amplitude vs. pressure of the electric output signal of conversion at least approximately accords with the desired characteristic. Then band pass first filtering is performed with the determined filter frequency as band pass center frequency.

Thereby, another embodiment comprises performing the first filtering as band pass filtering, thereby selecting bandwidth of band pass first filtering with the target of achieving a desired signal to noise ratio.

Thereby, a further embodiment comprises selecting an upper cut-off frequency of the second filtering below the transition frequency.

Thereby, a further embodiment comprises performing the second filtering with a center frequency there where the derivative of spectral amplitude vs. pressure of the electric output signal at least approximately accords with a desired characteristic.

Thereby, still a further embodiment comprises performing the second filtering with a bandwidth for a desired signal to noise ratio.

Thereby, an embodiment further comprises performing the second filtering and realizing a desired sensitivity of the output signal of the second filtering under consideration of noise by performing the following steps subsequently once or repeatedly in one or more than one loops:

a) Determining a center frequency of the second filtering there where the derivative of spectral amplitude vs. pressure of the electric output signal at least approximately accords with a desired characteristic and

b) tailoring bandwidth of the second filtering for a desired signal to noise ratio.

Still under the third aspect one embodiment comprises performing monitoring in a predetermined pressure range between a minimum pressure value and a maximum pressure value;

performing at least one of the following steps:

second filtering with a band pass filter characteristic which has an upper cut-off frequency not higher than a transition frequency and which has a lower cut-off frequency which is above modulation frequency of the periodic wavelength modulation;

first filtering with a filter characteristic which has a lower cut-off frequency not lower than the transition frequency;

whereby the transition frequency is determined in the spectrum of the electric output signal there where the spectrum envelopes of the electric output signal at said minimum pressure value and at said maximum pressure value intersect.

6

Thereby, a further embodiment comprises performing both first and second filterings. Still a further embodiment comprises performing the first filtering as a band pass filtering.

Thereby, a further embodiment comprises performing the first filtering with a lower cut-off frequency which is higher than the just addressed transition frequency. Thereby, in another embodiment first filtering is performed between the transition frequency and a noise limit frequency. The noise limit frequency is defined there where noise energy of the electric output signal equals signal energy of the electric output signal at the addressed minimum pressure value.

Thereby, in a further embodiment band pass first filtering is selected so that the energy difference in the filtered spectrum of the electric output signal between applying the maximum pressure value and the minimum pressure value becomes maximum.

Thereby, still a further embodiment comprises selecting the band pass first filtering under the constraint that noise energy of the electric output signal there where the first filtering is effective is at most equal to signal energy at the maximum pressure as predetermined.

Thereby, in a further embodiment the upper cut-off frequency of the second filtering is selected below the transition frequency as addressed.

Still further, in an embodiment second filtering is performed there where the energy difference in the spectrum of the electric output signal of conversion is maximum between applying the maximum predetermined pressure value and the minimum predetermined pressure value.

Still in a further embodiment under all three aspects of the present invention the gas species monitored is oxygen.

Still in a further embodiment under all three aspects of the present invention there is generated a reference pressure indicative signal by performing the monitoring according to the present invention at a predetermined pressure of the gas species. Yet under a further embodiment there is generated a resulting pressure indicative signal in dependency of a difference of the reference pressure indicative signal and the pressure indicative signal.

Still a further embodiment under all the aspects of the present invention comprises monitoring transmission of the laser light along a trajectory path to which the gas species is or is to be applied and thereby generating a transmission indicative signal. Signals from which the pressure indicative signal depends are then weighted in dependency of the transmission indicative signal.

Still a further embodiment of the invention under all its aspects further comprises providing a gas with the gas species in at least one container which is transparent for the addressed laser light.

Thereby, in a further embodiment such container is provided and monitored in ambient air.

Still in a further embodiment monitoring transparency of the trajectory path for the laser light includes the addressed transparent container, whereby a transparency indicative signal is generated. Signals wherefrom the pressure indicative signal depends are then weighted in dependency of the transmission indicative signal.

Thereby, in a further embodiment there is provided a third parallel channel as a calibration channel and there is generated the addressed transmission indicative signal in the said calibration channel.

In a further embodiment a reference signal is generated by performing the monitoring according to the present invention at a reference container with a predetermined amount of the gas species, whereby a result pressure indicative signal

is generated in dependency of the difference from said reference signal and the pressure indicative signal.

Still a further embodiment comprises checking the pressure indicative signal on plausibility.

Still a further embodiment comprises monitoring oxygen pressure in the addressed containers.

Still a further embodiment comprises that the addressed containers are filled with a product.

Still in a further embodiment the addressed containers are substantially of glass or plastic material. Thereby, still in a further embodiment such containers are vials.

Still in a further embodiment a container, whereat the gaseous content is monitored, is one of a multitude of containers which are conveyed in a stream towards, past and from the addressed monitoring.

Still in a further embodiment the container being monitored and the laser light transmitted therethrough are moved in synchronism during monitoring.

Still a further embodiment comprises monitoring subsequently the gas pressure in a multitude of containers which are conveyed subsequently towards, past and from the monitoring, thereby generating a reference pressure indicative signal by applying to the monitoring at least one reference container with a predetermined amount of the gas species to be monitored before monitoring one of the multitude of containers. There is thereby generated a result pressure indicative signal in dependency of the reference pressure indicative signal and the pressure indicative signal.

Further, in an embodiment the reference pressure indicative signal is generated each time just before monitoring one of the multitude of containers.

Still in a further embodiment reference pressure indicative signals from subsequent monitoring of reference containers with the predetermined amount of gas species are averaged and the addressed difference is formed in dependency of the result of such averaging.

The present invention is further directed on a method for manufacturing closed, possibly filled containers which are transparent to laser light and with a predetermined maximum amount of oxygen, which manufacturing method comprises the steps of manufacturing closed, possibly filled and transparent containers and subjecting these containers to a gas pressure monitoring as was disclosed above and according to one of the different aspects and embodiments of the present invention and rejecting containers if a signal which depends from the pressure indicative signal is indicative for an oxygen pressure in such container above a predetermined maximum value.

There is further proposed according to the present invention an apparatus for performing the present invention under all its method aspects.

With an eye especially on monitoring oxygen pressure the following dimensioning rules may be followed:

Center frequency of second filtering band pass, f_{ZII} , relative to laser wavelength modulation frequency f_C :

$$10 \leq f_{ZII}/f_C \leq 20$$

Center frequency of band pass applied for first filtering, f_{ZI} relative to modulation frequency f_C :

$$50 \leq f_{ZI}/f_C \leq 120$$

Pass bandwidth of second filtering relative to modulation frequency:

$$1 \leq B_{II}/f_C \leq 18$$

Pass bandwidth of band pass first filtering, B_I relative to modulation frequency f_C :

$$50 \leq B_I/f_C \leq 1000$$

Deviation H of wavelength modulation of the laser: At least 5 pm, thereby preferably

$$50 \text{ pm} \leq H \leq 500 \text{ pm.}$$

Further, one laser which may be applied in context with the present invention is the Vertical Cavity Surface Emitting laser.

The invention shall now be described by way of examples and with the help of figures. The figures show:

FIG. 1 simplified and schematically, an apparatus according to the present invention and performing the monitoring method according to the present invention;

FIG. 2 qualitatively over the wavelength axis, absorption lines of a gas species to explain wavelength modulation according to the present invention;

FIG. 3 the absorption spectra of a gas species as of oxygen at different pressures;

FIG. 4 qualitatively the spectrum of electric signals resulting from optoelectric conversion according to the present invention;

FIG. 5 qualitatively envelopes of spectra according to FIG. 4 at different pressures of gas species;

FIG. 6 qualitatively envelopes of the spectra according to FIG. 4 for different gas pressures defining for the caustic function;

FIG. 7 a representation in analogy to that of FIG. 6 for explaining determination of transition frequency with the help of the caustic function;

FIG. 8 schematically and qualitatively first filtering according to the present invention in one frequency area relative to the transition frequency as found according to FIG. 7;

FIG. 9 a simplified functional block diagram showing evaluation of filtering results according to FIG. 8;

FIG. 10 qualitatively an example of the course of an output signal of the embodiment of FIG. 9 as a function of pressure to be monitored;

FIG. 11 schematically by means of a signal flow/functional block diagram evaluation of a pressure indicative signal according to the present invention and with filtering according to FIG. 9;

FIG. 12 schematically and qualitatively second filtering according to the present invention in a second frequency area with respect to transition frequency determined according to FIG. 7;

FIG. 13 simplified, a functional block representation of performing filtering according to FIG. 12;

FIG. 14 qualitatively an example of the dependency of the output signal of the embodiment according to FIG. 13 from the pressure to be monitored;

FIG. 15 simplified and schematically by means of a signal flow/functional block diagram evaluating, a pressure indicative signal from the filtering according to FIG. 13;

FIG. 16 a further embodiment of the present invention, whereby filtering according to FIG. 8 and filtering according to FIG. 12 are exploited in combination;

FIG. 17 qualitatively, spectral envelopes of the spectra according to FIG. 4 for different pressure values for explaining tailoring the band pass filter according to FIG. 8;

FIG. 18 in a representation according to FIG. 17, tailoring band pass filter according to FIG. 12;

FIG. 19 again parameterized with the pressure, qualitatively spectral envelopes of spectra according to FIG. 4 under a second aspect of the invention for determining a transition frequency;

FIG. 20 in analogy to FIG. 8, tailoring first filtering in a frequency area above transition frequency as determined in FIG. 19;

FIG. 21 a representation in analogy to FIG. 9, thereby filtering according to FIG. 20;

FIG. 22 qualitatively an example of the dependency of output signal of embodiment according to FIG. 21 from gas pressure;

FIG. 23 in analogy to FIG. 11 evaluation of the result of filtering according to FIG. 21 for generating a pressure indicative signal;

FIG. 24 in analogy to FIG. 12 a representation of second filtering in a frequency area below transition frequency determined according to FIG. 19;

FIG. 25 in analogy to FIG. 13 a simplified functional block diagram for performing filtering according to FIG. 24;

FIG. 26 in analogy to FIG. 15, in a simplified form and by a functional block/signal flow diagram evaluating filtering according to FIG. 25 for generating a pressure indicative signal;

FIG. 27 qualitatively, an example of the dependency of output signal of the embodiment of FIG. 25 from pressure;

FIG. 28 a further embodiment according to the present invention and based on transition frequency as determined according to FIG. 19, thereby combining filtering according to FIGS. 20 and 24 for evaluating a pressure indicative signal;

FIG. 29 schematically and simplified, a twin-parallel measuring channel embodiment according to the present invention;

FIG. 30 the result of monitoring oxygen pressure with the embodiment according to FIG. 29 in one pressure range;

FIG. 31 in a representation according to FIG. 30, the results in a second pressure range;

FIG. 32 in a representation according to the FIGS. 30 and 31, the results when monitoring over a larger pressure range;

FIG. 33 a functional block/signal flow diagram of a part of an evaluation unit according to the present invention exploiting signal courses as e.g. shown in FIG. 32;

FIG. 34 most simplified, an apparatus according to the present invention and operating according to the method of the present invention for testing transparent closed containers in a stream with respect to gas content;

FIG. 35 a simplified signal flow/functional block diagram of an evaluation unit in a further variant, and

FIG. 36 a variant according to the present invention of the apparatus according to FIG. 34.

In FIG. 1 there is shown by means of a functional block diagram the generic structure of a monitoring system according to the present invention for monitoring pressure of a gas. The system comprises a laser arrangement 1 generating a laser beam B transmitted through a specimen 3 of gas containing the gas species to be pressure monitored. The laser beam B as transmitted through the specimen 3 is received at an optical input of an optoelectric converter arrangement 5 and is converted in an electric signal S_5 which is operationally connected to the input E_7 of an evaluation unit 7. The output signal S_7 at output A_7 of evaluation unit 7 is a pressure indicative signal indicative of the pressure of the gas species in specimen 3.

The laser arrangement 1 is modulatable with respect to λ_L of the light of beam B. As schematically shown in FIG. 1 it may be considered having a wavelength control input M to

which there is operationally connected a modulating generator 9. Generator 9 generates a periodic modulating signal to input M of laser arrangement 1 at a frequency f_C and with a peak to peak level value A_{pp} . Thereby, the beam B having generically a wavelength λ_L is wavelength-modulated with a frequency f_C around the value λ_{Lo} with a modulation hub H as a function of A_{pp} .

In FIG. 2 there is qualitatively shown absorption line $E_{abs}(G)$ of a gas species G to be monitored. The laser arrangement 1 is thereby wavelength-modulated so that the modulation hub H includes at least one of the absorption lines of the gas species, according to FIG. 2 e.g. just one absorption line.

In fact, the absorption line as schematically shown in FIG. 2 is an absorption spectrum as shown in FIG. 3. This figure shows as an example for a gas species to be pressure monitored, namely for oxygen, the absorption spectra for a pressure of 200 mbar (a), 75 mbar (b) and 40 mbar (c) of the specimen exclusively containing the gas species.

The absorption spectrum and its pressure dependency as exemplified for oxygen in FIG. 3 is with respect to its qualitative shape and behavior encountered for most gas species.

By modulating the wavelength of the laser beam B according to FIG. 1 and as shown in FIG. 2 and by transmitting the laser beam B through the gas specimen 3 as of FIG. 1 having the absorption spectrum as shown in FIG. 3, converted signal S_5 has a discrete energy spectrum as shown qualitatively in FIG. 4. There is a normally relatively high spectral line at zero frequency, as a DC component succeeded at rising frequency by a spectral line at modulation frequency f_C of the laser beam and higher order frequencies of f_C . The discrete energy spectrum of signal S_5 defines for the spectrum envelope EN as shown for the example of gas specimen, namely oxygen, qualitatively in FIG. 4.

In FIG. 5 the pressure—p—dependency of the envelope EN, thus EN(p) is shown, whereby the envelope according to (a) accords with the 200 mbar absorption spectrum (a) of FIG. 3 and, accordingly, the envelopes (b) and (c) with the respective absorption spectra (b) and (c) of FIG. 3. It has to be noted that the spectra and respectively their envelopes EN(p) as shown in FIGS. 4 and 5 are shown with a logarithmic energy scaling on the vertical axis e.g. according to a logarithm of signal energy to noise energy in dB.

In FIG. 6 there is purely qualitatively shown a multitude of envelopes EN(p) parameterized by the pressure p of the gas species in specimen 3, whereby the arrow " $p_{increase}$ " indicates the development of the envelopes as pressure p of the gas species increases. The collectivity of all the envelopes EN defines for a function course CA to which each of the collectivity of envelopes EN is a tangent. We call this function CA the caustic function.

The inventors of the present invention have investigated the behavior of signal S_5 in dependency of the pressure p of the gas species in specimen 3 of FIG. 1 and have found the spectral behavior in dependency of pressure as has been exemplified up to now here without a claim for scientific exactness.

This basic cognition has been exploited by the inventors in different manners as will be now further exemplified with the target to generate at the output of evaluation unit 7 as of FIG. 1 a pressure indicative signal S_7 .

According to a first aspect of the present invention and as shown in FIG. 7 the inventors have recognized that whenever the pressure of the gas species is to be monitored up to maximum pressure p_{max} a transition frequency f_{Tmax} is

11

important. If according to FIG. 6 the maximum pressure p_{max} up to which the pressure p of the gas species shall be monitored is selected, now switching to FIG. 7, the locus where the envelope $EN(p_{max})$ touches the caustic function CA in the spectral representation defines for the addressed transition frequency f_{Tmax} . In both frequency areas, I above f_{Tmax} and II below f_{Tmax} the pressure dependency of S_5 according to FIG. 1 is specific. Thereby, it has to be noted that the modulation frequency f_C is practically always below f_{Tmax} , especially for selected maximum pressures p_{max} as performed in practice. Thus, in a first embodiment the spectrum of S_5 is evaluated in the first addressed frequency area I to generate a pressure indicative signal.

It has to be noted that we speak generically of a frequency "area" if a one-side open frequency range is addressed and that we speak of a frequency "band" if a two-side closed frequency range is addressed.

According to FIG. 8 in one embodiment there is thus only evaluated the frequency area I, i.e. with a frequency f_I

$$f_{Tmax} \leq f_I$$

e.g. by providing a high-pass filter with the lower cut-off frequency not lower than the transition frequency f_{Tmax} .

Thus, the evaluation unit 7 as of FIG. 1 at least comprises, according to FIG. 9, a filter unit F_I operating in the frequency area I as a low-pass filter with a lower cut-off frequency not lower than the transition frequency f_{Tmax} . An example of the pressure— p —dependency of the output signal S_{FI} of filter F_I up to the maximum pressure to be monitored p_{max} is shown in FIG. 10, qualitatively. Energy and pressure are thereby linearly scaled in arbitrary units.

By prestoring a signal vs. pressure characteristic, as shown in FIG. 11 denoted as S_{FIref} in a memory unit 11_p, as e.g. in a look-up table unit, comparing the actual output signal S_{FI} of filter unit F_I with such characteristic in a comparing unit 13_p, the actual pressure value p_a as shown in dashed lines in FIG. 10 is evaluated as a pressure indicative signal. This signal may directly be used as output signal S_7 of evaluation unit 7.

In a second embodiment of the invention and with an eye on FIG. 7, the lower frequency area II, which is actually a frequency band, is exploited. Thereby, filtering is performed as shown in FIG. 12 by a filter with an upper cut-off frequency not higher than the transition frequency f_{Tmax} and with a lower cut-off frequency which is above the modulation frequency f_C of the laser wavelength modulation. Thus, there is performed in this embodiment as a second possible filtering, band pass filtering with a characteristic having an upper cut-off frequency not higher than the transition frequency and a lower cut-off frequency above the modulation frequency f_C of the periodic wavelength modulation.

In this embodiment and according to FIG. 13 the evaluation unit 7 comprises a filter unit F_{II} providing for the filter characteristic according to FIG. 12, thereby generating an output signal S_{FII} in dependency of which the pressure indicative signal S_7 is generated. Here too, signal S_{FII} is already *per se* pressure indicative.

In analogy to FIG. 10, FIG. 14 shows a qualitative dependency of output signal S_{FII} from the pressure p of the gas species in specimen 3 of FIG. 1 to be monitored.

In complete analogy to FIG. 11 and according to FIG. 15 for generating a signal which is indicative of the actual pressure of the gas specimen, the characteristic S_{FIIref} of output signal as of FIG. 14 is stored in a storing unit 11_{II}, e.g. in form of a look-up table. This characteristic S_{FIIref} is compared, as schematically shown by comparing unit 13_{II},

12

with the actual signal S_{FIIa} , thereby generating at the output of comparing unit 13_{II} a signal according to the actual pressure value p_a in dependency of which the pressure indicative signal S_7 is generated.

In a further embodiment, the embodiments according to the FIGS. 8 to 11 and of FIGS. 12 to 15 are combined. This is shown in FIG. 16 which only needs little additional explanation in view of the explanations given to the respective single-filter embodiment. At the output of the respective comparing units 13_I and 13_{II} there appear signals which are both in fact indicative of the actually prevailing gas species pressure p_a in the gas specimen being monitored. Nevertheless, and as addressed by the different shaping of the characteristics in FIGS. 10 and 14, the redundancy of having two output signals indicative of the same actual pressure value p_a is exploited in a computing unit 15, principally to rise accuracy of pressure indication by the pressure indicative signal S_7 .

Generically spoken as evaluation of both frequency areas I and II by according filtering leads to two different signal dependencies from pressure according to S_{FI} and S_{FII} —these two characteristics may be different with respect e.g. to sensitivity (steepness of the characteristic), ambiguity, signal to noise ratio, etc.—it becomes possible to remedy the drawback of one characteristic, e.g. ambiguity, by the advantage of the second characteristic, e.g. unambiguity, thereby maintaining the advantage of the first characteristic, e.g. high sensitivity, without making use of the drawbacks of the second characteristic, e.g. low sensitivity. Thus, principally by exploiting filtering measurements in the two frequency areas—above and below the transition frequency f_{Tmax} —high flexibility is gained to generate an accurate pressure indicative signal with desired characteristics, which will normally be high sensitivity, unambiguity and high signal to noise ratio.

Further and with an eye on filtering in the first frequency area I according to FIG. 8 and as shown in that figure with dashed-pointed lines, it is a variant to perform this first filtering as band pass filtering. The reason why this is considered may be seen in FIG. 6. As the envelope EN according to the selected maximum pressure p_{max} crosses the zero line as at point N of FIG. 6, noise energy becomes predominant. Therefore, by performing band pass filtering in frequency area I, noise energy in the signal S_{FI} is reduced.

Further, and especially with an eye on combining the filtering in the first frequency area I with filtering in the second area II according to the embodiment of FIG. 16, separation of the two filters is reached by performing first filtering F_I with a lower cut-off frequency f_{I-} higher than the transition frequency f_{Tmax} as shown in FIG. 8 and/or to perform the second filtering F_{II} as shown in dashed line in FIG. 12 with an upper cut-off frequency f_{II+} at a frequency below the transition frequency f_{Tmax} .

Whenever first filtering comprises band pass filtering in a frequency band BP_I of FIG. 8, there remains still a degree of freedom, where the center frequency f_{ZI} of this band pass filtering shall be established.

FIG. 17 shows a representation according to FIG. 6. When considering in the spectral representation in frequency area I, the energy in signal S_{FI} at a frequency f is in fact given, in dependency of pressure p , by the infinitesimal surface area as shown in hatched representation in FIG. 17. Therefore, it might be seen that at a prevailing pressure p this energy is proportional to the prevailing spectral amplitude at frequency f , with respect to envelope $EN(p)$. Sensitivity is thereby given by the derivative of that spectral amplitude vs. pressure. It has further to be noted (logarithmic scale) that

whenever a pressure-dependent spectral envelope $EN(p)$ reaches zero dB line, the noise energy in signal S_5 becomes equal to the signal energy therein, i.e. below that zero dB line, the noise energy becomes predominant. Therefore, it is one rule to find the central frequency f_{ZI} of band pass filtering in frequency area I, to establish a desired characteristic of derivative of spectral amplitude vs. pressure and to select as the addressed central frequency f_{ZI} of FIG. 8 that frequency f where this derivative accords at least approximately with the desired characteristic. Thereby, it has to be noted that a maximum derivative vs. pressure leads to maximum sensitivity. Because the characteristic of spectral amplitude vs. pressure at a given frequency f is not linear, one may e.g. select where, i.e. in which pressure range, maximum sensitivity shall be reached, in other words in which pressure range maximum sensitivity shall be realized.

Thereby, signal to noise ratio may be an additional target value. Is is dependent on the bandwidth BP_I of band pass filtering in frequency area I. The larger the bandwidth BP_I is selected, the smaller will be, as a generic rule, sensitivity in that the derivative of signal energy vs. pressure will be decreased, but, on the other hand, the larger will be the signal to noise ratio. This becomes evident when again considering FIG. 17, where a filter frequency band BP_I has been drawn in dashed line. The derivative of spectral energy of the signal S_{FI} is represented by the spectral surface area hatched under BP_I , the derivative of which vs. pressure becoming smaller with increasing bandwidth BP_I , the noise energy represented by the surface area under BP_I below zero dB becoming relatively smaller with increasing bandwidth.

Therefore, one approach to select central frequency f_{ZI} under consideration of signal to noise ratio is to loop one or more than one time through the steps of

- a) determining the central band pass filtering frequency f_{ZI} by finding that frequency f at which the derivative of spectral amplitude vs. pressure accords best with the desired characteristic;
- b) selecting bandwidth BP_I with respect to the central frequency found additionally considering signal to noise ratio and sensitivity, possibly readjusting center frequency and bandwidth with the target of realizing a desired optimum compromise between sensitivity and signal to noise ratio.

We have now described how filtering in frequency area I may be realized. Let's turn now to considerations about filtering in frequency area II.

As was explained in context with FIG. 12, filtering in frequency range II is performed by band pass filtering with an upper cut-off frequency f_{II+} at most at f_{Tmax} and with a lower cut-off frequency f_{II-} above modulation frequency f_C of laser wavelength modulation.

According to FIG. 18 and with an eye on selecting central frequency of band pass filtering, the same considerations prevail as were explained in context with FIG. 17 for band pass filtering in the frequency area I. That is, and with an eye on FIGS. 18 and 12, the central frequency F_{ZII} is selected by finding the frequency f whereat the derivative of spectral amplitude vs. pressure at least approximately accords with a desired characteristic. Thereby, additionally and with respect to selecting frequency band BP_{II} of band pass filtering F_{II} signal to noise ratio is considered, although being less critical as becomes evident from FIG. 18 than in the frequency area I. Again, with sensitivity to be reached as one target function and signal to noise ratio as a second target function the steps of

- a) determining the center frequency f_{ZII} of filter F_{II} is performed by establishing where the derivative of spectral

amplitude vs. pressure of the signal S_{FII} (FIG. 13) at least approximately accords with a desired characteristic and
b) tailoring bandwidth BP_{II} for a desired signal to noise ratio are performed once or more than one time in a looping manner.

We have now described the present invention under the aspect of having an upper maximum pressure p_{max} established up to which the pressure of the gas species shall be monitored.

Let's now consider a further aspect, where there is established a pressure range between a maximum pressure p_{max} and a minimum pressure p_{min} in which the pressure of the gas species shall be monitored according to the invention.

Thereby, FIGS. 1 to 5 still prevail as well as the explanations which were given in context with these figures.

FIG. 19 shows a representation in analogy to FIG. 6. It shows the spectral envelope for the maximum pressure to be monitored $EN(p_{max})$ as well as the spectral envelope for minimum pressure to be monitored $EN(p_{min})$. Thus, the pressure range Δp inclusive the limit values at p_{max} and p_{min} shall be monitored. In this case there is determined a transition frequency $f_{T\Delta p}$ there, where the envelope $EN(p_{min})$ crosses the spectral envelope $EN(p_{max})$. In analogy to f_{Tmax} this transition frequency $f_{T\Delta p}$ delimitates two frequency areas $I_{\Delta p}$ and $II_{\Delta p}$.

In one embodiment and according to FIG. 20 there is performed in the frequency area $I_{\Delta p}$ filtering as of high-pass filtering with a lower cut-off frequency $f_{\Delta pI-}$ which is not lower than the transition frequency $f_{T\Delta p}$. This results in an embodiment of the present invention according to FIG. 21 having a filter $F_{\Delta pI}$ operating in the frequency area $I_{\Delta p}$ of FIG. 19 as a high pass filter. The pressure indicative signal S_7 of evaluation unit 7 depends on output signal of filter $F_{\Delta pI}$, $S_{F\Delta pI}$. There results as a qualitative example an output signal $S_{F\Delta pI}$ of filter $F_{\Delta pI}$, according to FIG. 22. Energy and pressure are thereby again linearly scaled in arbitrary units.

In FIG. 23 there is shown in analogy with FIG. 11 the structure of the evaluation unit 7 for evaluating the filter signal $S_{F\Delta pI}$ to generate a pressure indicative signal S_7 . In view of the explanations given in context with FIG. 11, FIG. 23 and the respective embodiment becomes perfectly clear to the skilled artisan and needs no further explanation.

In a further embodiment of the invention and with an eye on FIG. 19 the lower frequency area $II_{\Delta p}$, which is again actually a frequency band, is exploited. Thereby, filtering is performed as shown in FIG. 24 by a filter with an upper cut-off frequency $S_{\Delta pII+}$ not higher than the transition frequency $f_{T\Delta p}$ and with a lower cut-off frequency $S_{\Delta pII-}$ which is above the modulation frequency f_C of the laser wavelength modulation.

In this embodiment and according to FIG. 25 the evaluation unit comprises in analogy to the embodiment as shown in FIG. 13 a filter unit $F_{\Delta pII}$ providing for the filter characteristic according to FIG. 24, thereby generating an output signal $S_{F\Delta pII}$, in dependency of which the pressure indicative signal S_7 is generated. Again the signal $S_{F\Delta pII}$ is per se pressure indicative.

In analogy to FIG. 15, FIG. 26 shows the structure of the evaluation unit 7 exploiting the output signal $S_{F\Delta pII}$ of filter $F_{\Delta pII}$ to establish for the pressure indicative signal S_7 . Here too, no additional explanations are necessary for the skilled artisan. Further, FIG. 27 shows in analogy to FIG. 14 quantitatively an example of the dependency of output signal $S_{F\Delta pII}$ from the pressure p of the gas species in specimen 3 of FIG. 1 being between the minimum and maximum pressures p_{min} and p_{max} .

In FIG. 28 a further embodiment is shown combining the embodiment as exemplified and explained with the help of the FIGS. 20 to 23 with the embodiment as explained in context with the FIGS. 24 to 27. The target of combining these embodiments is the same as was discussed in context with the combined embodiment of FIG. 16. In view of FIG. 16 and the explanations given thereto the embodiment of FIG. 28 needs no additional explanations for the skilled artisan.

With an eye on FIG. 8 and the explanations given thereto also in the case of providing filtering in the frequency area $I_{\Delta p}$ according to FIG. 20, and as shown in dashed-dotted lines, band pass filtering is applied. Further, again based on the explanations given in context with FIG. 8, in one embodiment, especially in the embodiment making use of filtering in both frequency areas $I_{\Delta p}$ and $II_{\Delta p}$, the lower cut-off frequency $f_{\Delta p I-}$ of filtering in the frequency area $I_{\Delta p}$ is higher than the transition frequency $f_{T\Delta p}$. Further, and referring to FIG. 12 and the explanations thereto, in a further variant according to FIG. 24 the upper cut-off frequency $f_{\Delta p II+}$ is selected below the transition frequency $f_{T\Delta p}$.

In spite of the fact that, with an eye on FIGS. 19 and 20, band pass filtering F_{FpI} in frequency area $I_{\Delta p}$ may be performed with respect to selecting central frequency $f_{Z\Delta p I}$ and bandwidth, under considerations similar to those given in context with FIGS. 17 and 18, it is of prime importance here that such band filtering is established between the transition frequency $f_{T\Delta p}$ and a noise limit frequency f_N (see FIG. 19) where at p_{min} the noise energy in signal S_s equals signal energy therein. Thereby, such band pass filtering may be performed so that the energy difference in the spectrum between the envelope $EN(p_{max})$ and the envelope $EN(p_{min})$ becomes maximum.

It has to be noted that, as was mentioned, the spectral envelopes $EN(p)$ as shown in the various figures are merely qualitative. Nevertheless, in FIG. 19 a bandwidth $BP_{\Delta p I}$ is arbitrarily shown with the hatched surface representing the addressed energy difference.

Principally band pass filtering in frequency area $I_{\Delta p}$ is performed by respective selection of center frequency $f_{Z\Delta p I}$ (see FIG. 20) and bandwidth $BP_{\Delta p I}$ under the constraint that noise energy of the output signal S_s where the filtering is effective is at most equal to signal energy at maximum pressure to be evaluated.

Considering frequency area $II_{\Delta p}$ and with an eye on FIG. 24 band pass filtering is performed with a lower cut-off frequency $f_{\Delta p II-}$ above modulation frequency f_e of the periodic wavelength modulation and with an upper cut-off frequency $f_{\Delta p II+}$ which is at most equal to the transition frequency $f_{T\Delta p}$. Again with an eye on FIG. 19 the central frequency and the bandwidth of this filtering is selected so as to perform band pass filtering there, where the energy difference in the envelope spectrum of signal S_s between applying the maximum pressure to be monitored p_{max} and the minimum pressure p_{min} to be monitored to become maximum. The respective energy difference to be considered is shown in FIG. 19 in frequency area $II_{\Delta p}$ in hatched representation.

We have shown embodiments for evaluating pressure indicative signals making use of single filtering above or below of a transition frequency f_{Tmax} and $f_{T\Delta p}$ respectively or to combine filtering in two parallel channels, thereby performing filtering in both frequency areas above and below the respective transition frequency f_{Tmax} , $f_{T\Delta p}$. Thus, in the latter embodiment and as shown in FIG. 29 at least two, namely a first monitoring channel K_I and a second monitoring channel K_{II} , are formed with filtering F_I and F_{II} ,

respectively tailored in dependency on how transition frequency f_T has been defined. Thus, FIG. 29 is an embodiment as of FIG. 16 or 28.

Thus, dependent on the output signal of the respective first and second filtering F_I , F_{II} in the respective channels K_I and K_{II} the pressure indicative signal is computed.

Thereby, there is exploited that the result of the respective first and second filtering in the channels K_I and K_{II} becomes different. I.e. the output of filter F_I varies as a function of the pressure of the gas species to be monitored differently than the result of the second filtering F_{II} .

In FIG. 30 there is shown the result of monitoring pressure of a gas specimen, thereby of oxygen as an example, by showing the output signal S_{FI} and S_{FII} of filtering in the respective channels K_I and K_{II} as of FIG. 29. The signals $S_{FI,II}$ are scaled in arbitrary but equal units.

For filtering in frequency area I a band pass filter is used. The filters are not optimized with respect to sensitivity and signal to noise ratio. The lower cut-off frequency of band pass filter in channel K_I as well as upper cut-off frequency of band pass filter in channel K_{II} are nevertheless selected so as to be clearly distant from both transitions frequencies f_{Tmax} and $f_{T\Delta p}$.

It may be seen that there is generated a first output signal S_{FI} of first filtering which has in the pressure subrange Δp_s of about 0 mbar to 50 mbar out of the overall monitored pressure range Δp of about 0 mbar to 75 mbar a derivative vs. pressure, the absolute value of which being larger than the absolute value of the derivative vs. pressure characteristic of the signal S_{FII} , i.e. of filtering in channel K_{II} . In FIG. 31 there is shown in a representation analog to that of FIG. 30 the respective output signals S_{FI} and S_{FII} of the respective channel filtering in a different range of pressure, again as an example of oxygen pressure, namely in the range of about 75 to 200 mbar. From FIG. 31 it might be seen that here within the pressure subrange Δp_s of about 110 to 190 mbar the absolute value of the derivative of signal S_{FI} vs. pressure is larger than such derivative of the signal S_{FII} . Thus, one can say that in a two-channel approach according to FIG. 29 there is generated by first filtering F_I a first signal with a first derivative vs. pressure in a predetermined pressure range Δp and by means of second filtering F_{II} a signal with a second derivative vs. pressure in the predetermined pressure range Δp , whereby absolute values of one of the derivatives is smaller than absolute values of the other derivatives in at least one pressure subrange Δp_s within the predetermined pressure range Δp . Thereby, the derivatives are considered without taking noise into account, i.e. by smoothing the respective output signals, because noise would provide for random derivatives vs. pressure characteristics.

FIG. 32 shows in a representation in analogy to that of FIGS. 30 and 31 the course of signal S_{FI} and at S_{FII} at a predetermined pressure range to be monitored of about 0 to 195 mbar. Therefrom, it might be seen that first filtering F_I in channel K_I which accords to filtering in the frequency area I above transition frequency f_{Tmax} or $f_{T\Delta p}$ has derivatives vs. pressure which are exclusively positive in pressure subrange Δp_{s1} and exclusively negative in a second pressure subrange Δp_{s2} out of the overall predetermined pressure range Δp . Further, the derivatives of the second signal S_{FII} are exclusively of one signum in the overall pressure range Δp .

Further, the absolute values of the derivatives of the first signal S_{FI} are larger at least in the subrange Δp_{s1} , thereby again not considering noise.

The signal as shown in the FIGS. 30 to 32 are typical for gases and respective filtering in the two frequency areas above and below transition frequency.

The results as shown have been monitored on oxygen gas. With an eye on the signal courses of FIG. 32 in the pressure range Δp to be monitored it is evident that the signal S_{FI} has a sensitivity in the pressure subranges Δp_{s1} and Δp_{s2} which is larger than the sensitivity of signal S_{FI} in the respective pressure subranges. On the other hand the signal S_{FI} is ambiguous in that one signal value of S_{FI} may be indicative for two pressure values which are highly different. For instance and as shown in FIG. 32 a signal value S_o of signal S_{FI} may be indicative for a pressure of about 25 mbar, but also for a pressure of about 170 mbar.

Although having a smaller sensitivity, signal S_{FII} is not ambiguous over the range Δp including the subranges Δp_{s1} and Δp_{s2} .

Thus, in one embodiment of signal computing as by unit 15 of FIG. 29 the following may be done, according to FIG. 33:

Principally from a signal dependent on the second signal S_{FII} from channel K_{II} according to FIG. 29, which accords with filtering results in frequency area II, the prevailing pressure subrange for the instantaneously prevailing result of first filtering, S_{FI} , is determined. As schematically shown in FIG. 33 the prevailing actual signal S_{FII} is compared with the prestored reference characteristic S_{FIIref} in unit 11_{II} by comparing unit 13_{II}. The comparison result at the non-ambiguous characteristic S_{FIIref} is indicative for an estimate pressure value p_e and is fed to a comparator unit 20. There the estimate pressure value p_e , i.e. the signal indicative for that value, is compared with limit values for the pressure subranges Δp_s , according to Δp_{s1} and Δp_{s2} of FIG. 32. The result of this comparison is an output signal which is indicative of the pressure subrange Δp_s , namely with an eye on FIG. 32 of either Δp_{s1} or Δp_{s2} .

The output signal of comparator unit 20 controls via a control input C_{21} the activation of either a storage unit 23a or 23b both being e.g. look-up tables. In the one storage unit 23a the characteristic S_{FIref} of the output signal of first filtering F_I in the first pressure subrange according to Δp_{s1} as of FIG. 32 is prestored, whereas in storage unit 23b again e.g. in the form of a look-up table, the characteristic S_{FIref} of the result of first filtering F_I in the pressure subrange Δp_{s2} is prestored.

The pressure subrange indicative signal Δp_s controls which of the two prestored characteristics is compared in a further comparator unit 25 with the prevailing result signal S_{FI} of first filtering F_I . This is schematically shown in FIG. 33 by a controlled selection unit unit 27.

Thus, after having determined from a signal which depends on second filtering F_{II} the prevailing pressure subrange Δp_s from a signal which depends on the result of first filtering, F_I in the subrange Δp_s the pressure indicative signal is established.

Before proceeding to describing further embodiments of the invention practically established dimension indications shall be given which have been used for oxygen pressure monitoring:

Center frequency f_{ZII} of second band pass filter F_{II} relative to modulation frequency f_C :

$$10 \leq f_{ZII}/f_C \leq 20$$

Center frequency f_{ZI} of first band pass filter F_I :

$$50 \leq f_{ZI}/f_C \leq 120$$

Bandwidth of second band pass filter B_{FII} :

$$1 \leq B_{FII}/f_C \leq 18$$

Bandwidth of first band pass filter B_I :

$$50 \leq B_I/f_C \leq 1000$$

Wavelength derivation H according to FIG. 1 of laser modulation at least 5 pm, thereby preferably:

$$50 \text{ pm} \leq H \leq 500 \text{ pm}$$

Thereby, as a modulatable laser a Vertical Cavity Surface Emitting Laser was used, modulated at $f_C \sim 800$ Hz.

The invention with all different embodiments described up to now is, in a further embodiment, applied in a practical system as will now be described, whereby further embodiments shall be addressed.

In FIG. 34 there is schematically shown a system for monitoring pressure of a gas species in closed containers which are transparent to the laser light as was described in the modulated wavelength band and which may be filled or not. Such containers, wherein the oxygen pressure has to be accurately monitored, are e.g. vials of glass or plastic containing a filling material which is not to be exposed to oxygen.

Thus, in a further embodiment of the present invention the gas species to be monitored is within a closed and transparent container, transparent to the light of the laser as applied. According to FIG. 34 such containers as e.g. glass or plastic material vials 27 are conveyed after having been filled and sealingly closed and possibly stored during shorter or longer time spans in atmospheric air, by means of a conveyor arrangement 29 as e.g. a carousel conveyor towards a gas pressure, specifically an oxygen pressure, monitoring station 31. Therein and according to FIG. 1 there is provided laser arrangement 1 modulatable as was described by means of modulating generator 9. The wavelength modulated laser beam B enters after having passed a container 27 under test as transmitted beam B_T , receiver unit 29 with optoelectric converter 5 according to FIG. 1 and subsequent evaluation unit 7. Depending on the construction of the system the container 27 under test continues to be conveyed by conveyor 29 during gas pressure monitoring, whereby in this case laser arrangement 1 and receiver unit 29 are moved along a predetermined trajectory path in synchronism with the conveyed container 27 under monitoring test.

Otherwise, in another construction, the container 27 under test is stopped so that the laser arrangement 1 and receiver arrangement 29 may be stationary.

The energy of the transmitted laser beam B_T may thereby be influenced by the prevailing transparency of the overall transmission path in fact between laser arrangement 1 and optical input port of receiver unit 29, thereby especially by varying transparency of the container, be it due to tolerances of container material, of container wall contamination etc.

This is taken into account in that there is generically performed a transmission indicative measurement. As transmission influences the energy of the signals which were described to be filtered as well as significance of reference characteristics as in look-up tables with which actual filtering results are compared, the transmission indicative signal is applied for weighing such signals.

In spite of the fact that a prevailing transparency in the transmittance path 3 according to FIG. 1 may be measured as by making use of a separate laser beam, in one embodiment the laser beam B itself is exploited to provide also for the transparency indicative information. With an eye on FIG. 4 it was explained that the spectrum of signal S_5 contains the distinct spectral line at the modulation frequency f_C . Dependent on how wavelength modulation of the laser beam is realized, the spectral component at f_C will be of higher or

lower energy. When making use e.g. of a Vertical Cavity Surface Emitting Laser (VCSEL), where the center wavelength of emission spectrum is tunable and thus modulatable by amplitude modulating the forward current as is taught in H. P. Zappe et al. "Narrow-linewidth vertical-cavity surface-emitting lasers for oxygen detection", Appl. Opt. 39 (15), 2475-2479 (May 2000), the energy of the transmitted laser beam at frequency f_C is quite large. Therefrom results that the energy of the signal S_5 is per se indicative of transmission. As has been explained in all filtering modes for evaluating the pressure indicative information in signal S_5 the energy at the frequency f_C is not considered by selecting all filtering with a lowest-most cut-off frequency above the modulation frequency f_C .

According to FIG. 35 there is therefore provided a third channel K_{CAL} as a calibration channel, whereat directly or possibly and as shown in dashed line via selective band pass filtering at frequency f_C , a transmission indicative signal S_{Tr} is generated. This transmission indicative signal is used generically for weighing signals from which the pressure indicative signal depends. In the embodiments as were described and according to FIG. 35, whereat the filtering result signals S_{FI} and S_{FII} are used to find the according pressure-dependent value in look-up tables 11_I and 11_{II} , irrespective which transition frequency f_{Tmax} or $f_T\Delta p$ has been selected, the transmission indicative signal S_{Tr} is applied to calibration units 33 which are provided at the output of the look-up table units 11_I , 11_{II} as well as at the outputs of the filtering units F_I and F_{II} .

Thus, the output signals which appear at the outputs of the respective comparing units 13 become independent from the instantaneously prevailing transmission characteristics of the transmission path 3 according to FIG. 1 and with an eye on FIG. 34 independent of possibly varying transmission of containers 27 which are monitored in line, i.e. in a stream of subsequent containers, with respect to the pressure of a specific gas species contained therein, as was addressed, especially of oxygen.

Still a further embodiment comprises to perform the gas species pressure monitoring as was described up to now upon such gas specimen which has a predetermined known pressure, be it for checking purposes of the overall functioning and of accuracy of the system as described, be it for providing a reference pressure indicative signal on the gas species under test. With an eye on the teaching of FIG. 34 providing for such standard monitoring may be done always after a predetermined number of containers 27 have been tested and may even be done before each of the containers 27 is monitored on prevailing gas species, in the present case on oxygen.

In FIG. 35 there is shown one embodiment for performing a standard or reference monitoring as was just addressed before gas species pressure monitoring at each of the containers 27.

According to FIG. 36 each container 27 to be tested and once conveyed by conveyor 29 into the monitoring station 31 according to FIG. 34 is gripped by a transfer member 35. The transfer member 35 may comprise a tubular member as shown with controlled gripping arrangement 37 and with a laser transition pass through 39. The transfer member 35 is movable perpendicularly to the path of conveyor 29 up and down as shown by the double-arrow F, thereby driven in a controlled manner by a drive 41. The laser arrangement 1 and the optoelectric converter arrangement 5 are located above the conveyor 29, so that whenever a container 27 to be tested is gripped in the position as shown, and is then lifted by means of drive 41 and member 35 in a monitoring

position where the pass-through 39 opens the transition path for laser beam B. In FIG. 36 the transfer member 35 is shown in its lowered position, where the next container 27 to be tested is about to be gripped. The transfer member 35 further holds a standard or reference container 27_{ST} , wherein a predetermined amount of the gas species to be monitored is present, resulting in a predetermined pressure at a given temperature. The standard container 27_{ST} within transfer member 35 is only rarely replaced. Together with transfer member 35 it is moved by means of controlled drive 41 up and down and as a second pass-through 39_{ST} is provided in transfer member 35 at a position according to the mounting position of standard container 27_{ST} , whenever the transfer member 35 is in the position as shown in FIG. 36, the laser beam B transits through the standard container 27_{ST} . Thereby, reference monitoring is performed. In dashed line FIG. 36 shows the position of standard container 27_{ST} whenever container 27 to be monitored is lifted in monitoring position.

Due to the fact that the pressure of a gas species in the closed containers is dependent on the temperature which is substantially equal, as given by the surrounding, for the containers to be tested and for standard container 27_{ST} within transfer member 35, the gas species contained within standard container 27_{ST} will be subjected to pressure variations due to the same temperature variations as the gas species possibly contained in the containers 27 to be tested. According to FIG. 36 after optoelectric conversion of the transmitted laser beam B signal processing is performed as was largely explained up to now finally at the signal computing unit 15. The signal generated at the output A_{15} of computing unit 15 represents, as was explained, a signal which is indicative of the pressure of the specific gas species as momentarily monitored. As shown in FIG. 36, the standard or reference container 27_{ST} is also gas pressure monitored, and the result at the output A_{15} is stored in a storing unit 41. Then the subsequent monitoring test result, which is generated at a container 27 to be tested, is fed to a difference forming unit 43 together with the stored reference result value in storing unit 41. Therefore, an output signal D_p at the output of difference unit 43 is generated, which is indicative of the difference between the gas pressure indicative signal as monitored at the reference or standard container 27_{ST} and the next prevailing conveyed container 27 to be test monitored.

A time control unit 45 controls, as schematically shown in FIG. 35, storing of the output signal of unit 15 in storage unit 41, applying the prevailing output signal of unit 15 together with the stored reference signal to the difference unit 43 and up/down movement F of transfer member 35 via controlled drive 41.

Further, and as only schematically shown in FIG. 36, the resulting difference signal D_p is fed to a threshold unit 45, where it is checked whether it reaches a predetermined threshold value or not, as preestablished by a threshold setting unit 47. Dependent on the comparison result of D_p with the preset threshold value, the container 27 which is momentarily under test will be considered as fulfilling predetermined conditions with respect to the content of the gas species and will then be considered to be a closed, transparent container which holds at most a predetermined maximum amount of gas species, especially of oxygen, thus being a regular container. Those containers, which do not fulfill the said conditions and thus have e.g. a too high amount of oxygen, are discarded as shown in FIG. 36 schematically with discarding switch S_{45} controlled from threshold checking at threshold unit 45.

21

As a further embodiment the storage unit **41** is replaced by an averaging unit, whereat subsequent reference pressure indicative signals monitored at standard containers **27_{ST}** are averaged and the averaged result is fed to the difference unit **43**. Thereby, whenever the standard container **27_{ST}** is corrupt for whatever reason, its monitoring will not abruptly change the averaging result and thus the prevailing difference result D_p will still remain accurate for some containers **27**, thereby not leading to containers **27** under test being erroneously considered as fulfilling the predetermined gas conditions or not. Thereby (not shown) whenever the monitoring result of a standard container **27_{ST}** leaves a predetermined signal range, an alarm may be established informing about corruption of the standard container **27_{ST}**.

Further, FIGS. **34** and **35** show single test station embodiments. For increasing throughput of tested containers **27** more than one test station **31** may be provided, operating in parallel, so that the test cycle time is divided by the number of parallel test stations allowing for increased speed of conveying the containers **27** by means of conveyor **29**.

By means of the disclosed technique for gas pressure monitoring, applied for testing oxygen content in glass or plastic vials, test cycle times lower than 0.3 sec. were reached, allowing to accordingly test containers in a stream and thereby to test every single container **27**.

The invention claimed is:

1. A method of monitoring pressure of a gas species up to at most a predetermined maximum pressure value comprising

exposing said gas species to transmission of laser light; periodically modulating the wavelength of said laser light over a wavelength band including at least one absorption line of said gas species;

optoelectrically converting said transmitted laser light, thereby generating an electric output signal;

performing at least one of

first filtering said electric output signal with a filter characteristic having a lower cut-off frequency not lower than a transition frequency and of

second filtering said electric output signal with a band pass filter characteristic having an upper cut-off frequency not higher than said transition frequency and a lower cut-off frequency above modulation frequency of said periodic wavelength modulation,

thereby determining said transition frequency in the spectrum of said electric output signal there, where the caustic function of the pressure-dependent spectrum envelopes of said electric signal touches the envelope of said spectrum at said maximum pressure, and evaluating the output of at least one of said filterings as a pressure indicative signal.

2. The method of claim **1**, further comprising performing both of said first and second filterings.

3. The method of claim **1**, further comprising performing said first filtering as a band pass filtering.

4. The method of claim **1**, further comprising performing said first filtering with a lower cut-off frequency higher than said transition frequency.

5. The method of claim **1**, further comprising performing said first filtering as a band pass filtering and determining a filter frequency above said lower cut-off frequency of said first filtering there, where the derivatives of spectral amplitude vs. pressure of said electric output signal at least approximately accord with a desired characteristic and performing said band pass first filtering with said filter frequency as band pass center frequency.

22

6. The method of claim **1**, performing said first filtering as band pass filtering and selecting bandwidth of said band pass first filtering with the target of achieving a desired signal to noise ratio.

7. The method of claim **1**, further comprising performing said first filtering as a band pass filtering and realizing a desired sensitivity of said output signal of said band pass first filtering under consideration of noise by performing the following steps one or more than one time:

a) determining a filter frequency above said lower cut-off frequency of said first filtering there where the derivative of spectral amplitude vs. pressure of said electric output signal at least approximately accords with a desired characteristic and establishing the band pass center frequency of said band pass first filtering at said filter frequency;

b) tailoring bandwidth of said band pass first filtering for a desired signal to noise ratio range.

8. The method of claim **1**, further comprising selecting said upper cut-off frequency of said second filtering below said transition frequency.

9. The method of claim **1**, further comprising performing said second filtering with a center frequency there where the derivative of spectral amplitude vs. pressure of said electric output signal at least approximately accords with a desired characteristic.

10. The method of claim **1**, further comprising performing said second filtering with a bandwidth for a desired signal to noise ratio.

11. The method of claim **1**, further comprising realizing a desired sensitivity of said output signal of said second filtering under consideration of noise by performing the following steps one or more than one times:

a) determining a center frequency of said second filtering there where the derivative of spectral amplitude vs. pressure of said electric output signal at least approximately accords with a desired characteristic and

b) tailoring bandwidth of said second filtering for a desired signal to noise ratio.

12. A method of monitoring pressure of a gas species within a predetermined pressure range between a maximum pressure value and a minimum pressure value comprising

exposing said gas species to transmission of laser light; periodically modulating the wavelength of said laser light over a wavelength band including at least one absorption line of said gas species;

optoelectrically converting said transmitted laser light, thereby generating an electric output signal;

performing at least one of

first filtering said electric output signal with a filter characteristic having a lower cut-off frequency not lower than a transition frequency and of

second filtering said electric output signal with a band pass filter characteristic having an upper cut-off frequency not higher than said transition frequency and a lower cut-off frequency above modulation frequency of said periodic wavelength modulation,

thereby determining said transition frequency in the spectrum of said electric output signal there where the spectrum envelopes of said electric output signal at said minimum and at said maximum pressure values intersect, and

evaluating the output of at least one of said filterings as a pressure indicative signal.

13. The method of claim **12**, further comprising performing both of said first and second filterings.

23

14. The method of claim 12, further comprising performing said first filtering as a band pass filtering.

15. The method of claim 12, further comprising performing said first filtering with a lower cut-off frequency higher than said transition frequency.

16. The method of claim 12, further comprising performing said first filtering as band pass filtering between said transition frequency and a noise limit frequency, said noise limit frequency being defined there where noise energy of said electric output signal equals signal energy of said electric output signal at said minimum pressure value.

17. The method of claim 16, further comprising selecting said band pass first filtering so that the energy difference in the spectrum of said electric output signal between applying said maximum and said minimum pressure becomes maximum.

18. The method according to claim 17, thereby selecting said first band pass filtering under the constraint that noise energy of said electric output signal, where said filtering is effective, is at most equal to signal energy at said maximum pressure.

19. The method of claim 12, further comprising selecting said upper cut-off frequency of said second filtering below said transition frequency.

20. The method of claim 12, further comprising performing said second filtering there where the energy difference in the spectrum of said electric output signal between applying said maximum and applying said minimum pressure is maximum.

21. The method of claim 1, wherein said gas species is oxygen.

22. The method of claim 1, further comprising generating a reference pressure indicative signal by performing said monitoring at a predetermined pressure of said gas species.

23. The method of claim 22, further comprising generating a resulting pressure indicative signal in dependency of a difference of said reference pressure indicative signal and said pressure indicative signal.

24. The method of claim 1, further comprising monitoring transmission of said laser light along a trajectory path to which said gas species is or is to be applied, generating thereby a transmission indicative signal and weighting signals in dependency of said transmission indicative signal, from which said pressure indicative signal depends.

25. The method of claim 1, further comprising providing a gas with said gas species in a container transparent for said laser light.

26. The method claim 25, further comprising providing said container in ambient air.

27. The method of claim 25, further comprising monitoring transparency of a trajectory path for said laser light including said transparent container, generating thereby a transparency indicative signal and weighting signals in dependency of said transmission indicative signal, from which said pressure indicative signal depends.

28. The method of claim 27, further comprising providing a third parallel channel as a calibration channel and generating in said third channel said transmission indicative signal.

29. The method of claim 25, further comprising generating a reference signal by performing said monitoring at a reference container with a predetermined amount pressure of said gas species thereby generating a result pressure indicative signal in dependency of a difference from said reference signal and said pressure indicative signal.

30. The method of claim 1, further comprising checking said pressure indicative signal on plausibility.

24

31. The method of claim 25, further comprising monitoring oxygen pressure.

32. The method of claim 25, wherein said container is filled with a product.

33. The method of claim 25, wherein said container is substantially of glass or plastic material.

34. The method of claim 33, wherein said container is a vial.

35. The method of claim 25, wherein said container is one of a multitude of containers conveyed in a stream towards and from said monitoring, during said monitoring.

36. The method of claim 35, further comprising moving said container and laser light transmitted through said container in synchronism during said monitoring.

37. The method of claim 25, further comprising monitoring subsequently said gas pressure in a multitude of said containers conveyed subsequently towards and from said monitoring and generating a reference pressure indicative signal by applying to said monitoring at least one reference container with a predetermined amount of said gas species before monitoring one of said multitude of containers and generating a result pressure indicative signal in dependency of said reference pressure indicative signal and said pressure indicative signal.

38. The method of claim 37, further comprising generating said reference pressure indicative signal before monitoring each of said multitude of containers.

39. The method of claim 37, further comprising averaging subsequent of said reference pressure indicative signals and forming said difference in dependency of a result of said averaging.

40. A method for manufacturing closed, filled containers transparent to laser light and with a predetermined maximum amount of oxygen comprising manufacturing closed, filled, transparent containers, subjecting said containers to gas pressure monitoring according to one of the claims 1 to 39 and rejecting containers if the pressure indicative signal is indicative for an oxygen pressure in a container above a predetermined maximum value.

41. A method for monitoring pressure of a gas species comprising

exposing said gas species to transmission of laser light; periodically modulating the wavelength of said laser light over a wavelength band including at least one absorption line of said gas species;

optoelectrically converting said transmitted laser light, thereby generating an electric output signal;

inputting a signal dependent on said electric output signal to at least a first and a second, parallel, gas pressure monitoring channel;

performing in said first channel first filtering;

performing in said second channel second filtering;

performing said first filtering so that the output signal of said first filtering varies with a first characteristic as a function of said pressure;

performing said second filtering so that the output signal of said second filtering varies with a second characteristic as a function of said pressure;

said first characteristic being different from said second characteristic;

evaluating from combining signals dependent on the output signals of said first and second filtering said pressure indicative signal.

42. The method of claim 41, further comprising at least one of said first and of said second filtering as band pass filtering.

25

43. The method of claim 41, further comprising performing said first and second filtering in non-overlapping frequency areas of the spectrum of said electric output signal.

44. The method of claim 41, further comprising performing said first and said second filtering as band pass filtering.

45. The method of claim 41, further comprising performing said first and second filtering in first and second frequency ranges respectively, the energy of said electric output signal having a first energy vs. pressure characteristic in said first frequency range and a second energy vs. pressure characteristic in said second frequency range, said first and second energy characteristics being different from each others.

46. The method of claim 45, further comprising performing at least one of said first and second filtering as band pass filtering.

47. The method of claim 41, further comprising prestoring a first reference characteristic representing said first characteristic and prestoring a second reference characteristic representing said second characteristic and comparing signals dependent from output signals of said first and second filtering respectively with said first and second reference characteristics, thereby generating first and second pressure indicative signals.

48. The method of claim 41, said first filtering generating a first output signal with first derivatives vs. pressure in a predetermined pressure range, said second filtering generating a second output signal with second derivatives vs. pressure in said predetermined pressure range, absolute values of one of said derivatives being smaller than absolute values of the other of said derivatives in at least one common sub-pressure range of said predetermined pressure range, considering said derivatives without noise.

49. The method of claim 41, said second filtering generating a second output signal with exclusively positive or negative second derivatives vs. pressure in a predetermined pressure range, said first filtering generating a first output signal with first derivatives vs. pressure being exclusively positive in at least one pressure subrange of said predetermined pressure range and being exclusively negative in at least one second pressure subrange of said predetermined range, the absolute values of said second derivatives being smaller in at least one of said subranges than absolute values of said first derivatives in said at least one of said subranges and considering derivatives without noise.

50. The method of claim 49, further comprising determining from a signal dependent on said second output signal one of said pressure subranges.

51. The method of claim 50, further determining from a signal dependent on said first output signal in said determined pressure subrange a pressure indicative signal.

52. The method of claim 41, further comprising predetermining a maximum pressure to be monitored; performing at least one of

performing said second filtering with a band pass filter characteristic having an upper cut-off frequency not higher than a transition frequency and a lower cut-off frequency above modulation frequency of said periodic wavelength modulation and of

performing said first filtering with a filter characteristic having a lower cut-off frequency not lower than said transition frequency;

thereby determining said transition frequency in the spectrum of said electric output signal there where the caustic function of the pressure-dependent spectrum envelopes of said electric output signal touches the envelope of said spectrum at said maximum pressure.

26

53. The method of claim 52, further comprising performing said first and second filterings.

54. The method of claim 52, further comprising performing said first filtering as a band pass filtering.

55. The method of claim 52, further comprising performing said first filtering with a lower cut-off frequency higher than said transition frequency.

56. The method of claim 52, further comprising performing said first filtering as a band pass filtering and determining a filter frequency above said lower cut-off frequency of said first filtering there where the derivatives of spectral amplitude vs. pressure of said electric output signal at least approximately accord with a desired characteristic and performing said band pass first filtering with said filter frequency as band pass center frequency.

57. The method of claim 52, further comprising performing said first filtering as band pass filtering and selecting bandwidth of said band pass first filtering with the target of achieving a desired signal to noise ratio.

58. The method of claim 52, further comprising performing said first filtering as a band pass filtering and realizing a desired sensitivity of output signal of said band pass first filtering under consideration of noise by performing the following steps one or more than one time:

a) determining a filter frequency above said lower cut-off frequency of said first filtering there where the derivative of spectral amplitude vs. pressure of said electric output signal at least approximately accords with a desired characteristic and establishing the band pass center frequency of said band pass first filtering at said filter frequency;

b) tailoring bandwidth of said band pass first filtering for a desired signal to noise ratio.

59. The method of claim 52, further comprising selecting an upper cut-off frequency of said second filtering below said transition frequency.

60. The method of claim 52, further comprising performing said second filtering with a center frequency there where the derivative of spectral amplitude vs. pressure of said electric output signal at least approximately accords with a desired characteristic.

61. The method of claim 52, further comprising performing said second filtering with a bandwidth for a desired signal to noise ratio.

62. The method of claim 52, further comprising performing said second filtering and realizing a desired sensitivity of an output signal of said second filtering under consideration of noise by performing the following steps one or more than one time:

a) determining a center frequency of said second filtering there where the derivative of amplitude vs. pressure of said electric output signal at least approximately accords with a desired characteristic and

b) tailoring bandwidth of said second filtering for a desired signal to noise ratio.

63. The method of claim 41, further comprising performing said monitoring in a predetermined pressure range between a minimum pressure and a maximum pressure;

performing at least one of

said second filtering with a band pass filter characteristic having an upper cut-off frequency not higher than a transition frequency and a lower cut-off frequency above modulation frequency of said periodic wavelength modulation, and of

27

said first filtering with a filter characteristic having a lower cut-off frequency not lower than said transition frequency;

thereby determining said transition frequency in the spectrum of said electric output signal there where the spectrum envelopes of said electric output signal at said minimum and at said maximum pressure values intersect.

64. The method of claim 63, further comprising performing said first and second filtering.

65. The method of claim 63, further comprising performing said first filtering as a band pass filtering.

66. The method of claim 63, further comprising performing said first filtering with a lower cut-off frequency higher than said transition frequency.

67. The method of claim 63, further comprising performing said first filtering as band pass filtering between said transition frequency and a noise limit frequency, said noise limit frequency being defined there where noise energy of said electric output signal equals signal energy of said electric output signal at said minimum pressure value.

68. The method of claim 67, further comprising selecting said band pass first filtering so that the energy difference in

28

the spectrum of said electric output signal between applying said maximum and applying said minimum pressure becomes maximum.

69. The method according to claim 68, thereby selecting said band pass first filtering under the constraint that noise energy of said electric output signal, where said filtering is effective, is at most equal to signal energy at said maximum pressure.

70. The method of claim 63, further comprising selecting said upper cut-off frequency of said second filtering below said transition frequency.

71. The method of claim 63, further comprising performing said second filtering there where the energy difference in the spectrum of said electric output signal between applying said maximum and applying said minimum pressures is maximum.

72. The method of claim 63, further comprising selecting the upper cut-off frequency of said first filtering below said transition frequency.

* * * * *