

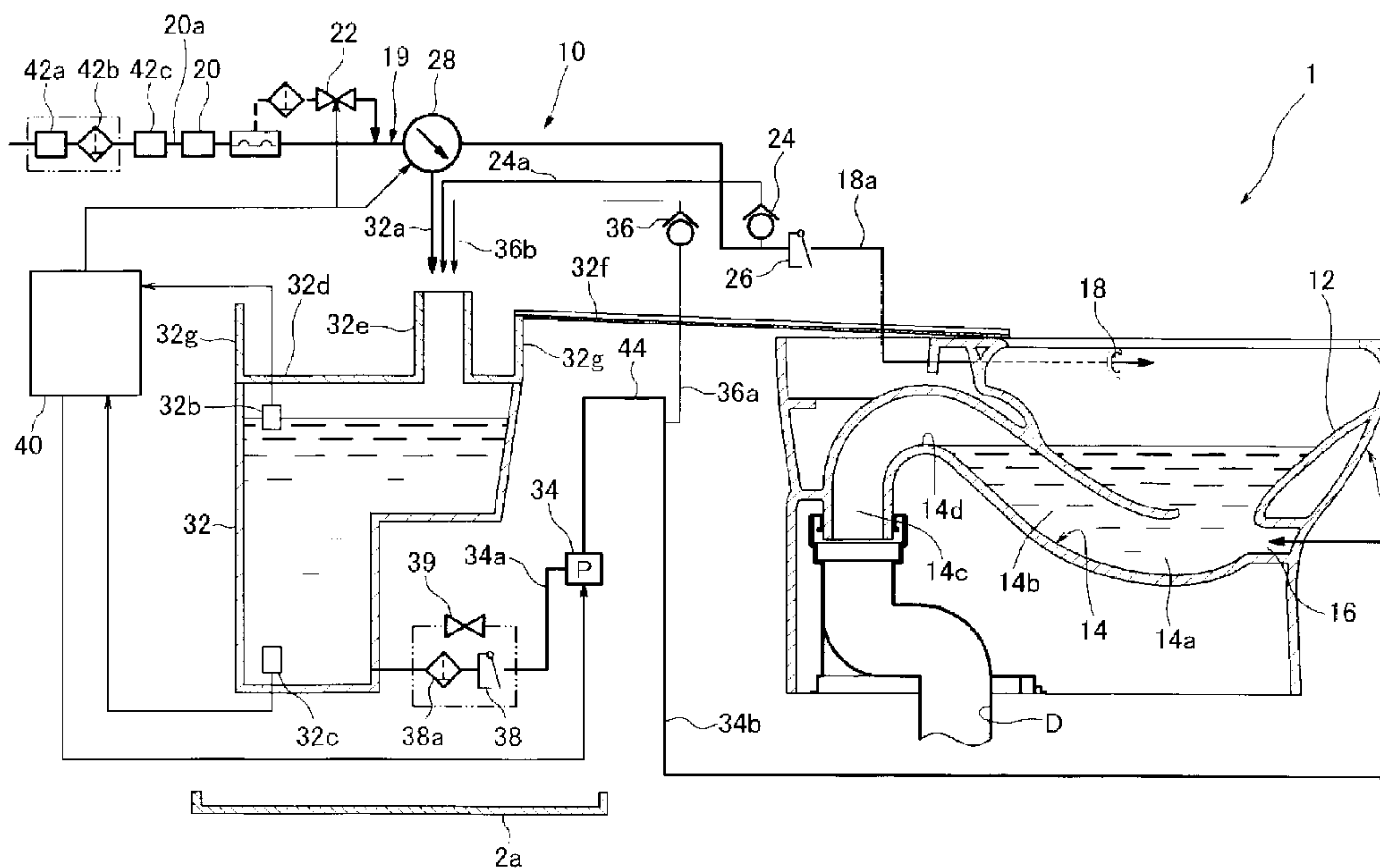

(86) Date de dépôt PCT/PCT Filing Date: 2007/12/25
 (87) Date publication PCT/PCT Publication Date: 2008/07/10
 (85) Entrée phase nationale/National Entry: 2009/03/18
 (86) N° demande PCT/PCT Application No.: JP 2007/074827
 (87) N° publication PCT/PCT Publication No.: 2008/081778
 (30) Priorités/Priorities: 2006/12/28 (JP2006-354726);
 2007/06/28 (JP2007-170796);
 2007/07/30 (JP2007-197557)

(51) Cl.Int./Int.Cl. *E03D 11/02* (2006.01),
E03D 5/01 (2006.01)
 (71) Demandeur/Applicant:
 TOTO LTD., JP
 (72) Inventeurs/Inventors:
 OKUBO, MAYU, JP;
 USHIJIMA, YOSHIKAZU, JP;
 SATO, YUICHI, JP;
 KATO, YOSHINOBU, JP;
 HAYASHI, RYOSUKE, JP;
 SHIBATA, SHINJI, JP
 (74) Agent: OGILVY RENAULT LLP/S.E.N.C.R.L.,S.R.L.

(54) Titre : DISPOSITIF DE TOILETTES A CHASSE D'EAU
 (54) Title: FLUSH TOILET



(57) **Abrégé/Abstract:**

A flush toilet device has a toilet body (2) having a bowl section (12), rim water discharge opening (18), a jet water discharge opening (16), and a discharge water trap conduit (14); a cistern (32); a pressurizing pump (34) for pressurizing flush water contained in the cistern to supply it to the jet water discharge opening; and pump control means (40) for controlling operation and rotation speed of the pressurizing pump to regulate the flow speed and flow rate of flush water discharged from the jet water discharge opening. The pump control means controls the rotation speed of the pressurizing pump such that flush water at a first flow rate for generating a siphon effect is discharged from the jet water discharge opening and then flush water at a second flow rate is discharged at the end of the siphon effect generated by the first flow rate, the second flow rate having a flow speed that can carry away human wastes and causes the siphon effect to continue by closing the cross section of any portion of the discharge water trap conduit.

ABSTRACT

The flush toilet of the present invention comprises a toilet main unit 2 provided with a bowl portion 12, a rim water spouting port 18, a jet water spouting port 16, and a
5 drain trap pipe 14; a reservoir tank 32; a pressurizing pump 34 for pressurizing flush water stored in the reservoir tank and supplying the flush water to a jet water spouting port; and pump control means 40 for controlling the operation and rpm of the pressurizing pump so as to control the flow speed and flow volume of flush water spouted from the jet water spouting port. The pump control means controls the rpm of
10 the pressurizing pump in order to spout a first flow volume from a jet water spouting port for generating a siphon action, and then to spout a second flow volume for continuing the siphon action when the siphon action generated by the first flow volume ends, at a flow speed capable of conveying waste, and in a way that seals a section of some part of the drain trap pipe.

FLUSH TOILET

Technical Field

0001

The present invention relates to a flush toilet, and more particularly to a flush
5 toilet cleaned by pressurized flush water.

Background Art

0002

Conventionally, flush toilets have been known in which, as set forth in Japanese
10 Patent 2953002 (Patent Document 1), a direct connection is made to a water main, and
without the use of a tank the bowl portion is flushed using water main pressure by
supplying flush water from a rim water spouting port provided on the rim of a toilet bowl
portion, and from a jet water spouting port provided on the bottom portion of the bowl
portion, which spouts water toward a drain trap pipe.

15 In addition, flush toilets have been known in which, as set forth in Patent
Document 2, rim spouted water is directly supplied as water main water from a rim water
spouting port, whereas jet spouted water is flush water stored in a tank and pressurized
by a pump, with this pressurized flush water then being expelled from a jet water
spouting port to flush the bowl portion.

20

0003

In the flush toilet set forth in JP2005-264469 (Patent Document 2), on the other
hand, flush water is first spouted from a rim water spouting port (rim flushing), then, after
spouting from the rim water spouting port is completed, flush water is spouted from a jet
25 water spouting port, and when spouting from the jet water spouting port is completed,
flush water is again spouted from the rim water spouting port.

0004

However, because the flush toilet set forth in Patent Document 1 supplies flush water to the toilet bowl portion using water main pressure alone, it cannot be used in localities with low water main pressure, or on the second or third floors of buildings and the like where water pressure is lower. Also, in this type of flush toilet, after the siphon action ended a relatively large volume of air was sucked from the trap pipe producing an unpleasant gurgling sound as the siphon action was cut off.

0005

10 In the flush toilet set forth in Patent Document 2, flush water stored in the tank is pressurized by a pump and expelled from a jet water spouting port, thus solving the problem of non-usability in low water pressure localities or sites, but the noise problem remained unsolved.

15 In addition, there has long been a requirement for water conservation, and a desire for low water-use flush toilets.

0006

20 At the same time, as noted above, in the flush toilet of Patent Document 2 flush water is spouted from the jet water spouting port after spouting of flush water from the rim water spouting port is completed, but because the volume of jet spouted water is low, a long time is required until the siphon effect is generated (siphon start), increasing flush water volume by that amount, such that the water conservation requirement is not satisfied.

25 0007

Furthermore, as described above, in the Patent Document 1 flush toilet both the rim water spouting port and the jet water spouting port are directly connected to the water main. For this reason, the volume of flush water supplied from the water main is fixed when flush water is spouted from the jet water spouting port during spouting from

the rim water spouting port (see Fig. 29 in Patent Document 1), therefore the volume of rim spout water must be reduced when spouting flush water from the jet water spouting port, resulting in less jet spouted water, thereby lengthening the time until the siphon effect is generated (siphon start), as in Patent Document 2, causing an increase by that amount in the volume of flush water and failing to satisfy the requirement for water conservation.

Disclosure of the Invention

0008

10 The present invention therefore has the object of providing a flush toilet which is not prone to the effects of water main pressure, has a reduced siphon cutoff sound when the siphon action stops, and satisfies the requirement for water conservation.

0009

15 The present invention also has the object of providing a flush toilet capable of reducing the time required until the siphon action is generated, and of satisfying the requirement for water conservation.

0010

20 To solve the above-described problems, a first invention of the present invention is a flush toilet cleaned by pressurized flush water, said flush toilet comprising a toilet main unit provided with a bowl portion, a rim water spouting port and jet water spouting port both for expelling flush water, and a drain trap pipe; a reservoir tank for storing flush water; rim spout water supply means for supplying flush water to the rim water spouting
25 port at a predetermined timing; reservoir water supply means for supplying flush water to the reservoir tank at a predetermined timing; a pressurizing pump for pressurizing flush water stored in the reservoir tank and supplying the flush water to the jet water spouting port; and pressurizing pump control means for controlling the operation of the pressurizing pump and the rpm thereof so as to control the flow speed and the flow

volume of flush water spouted from the jet water spouting port; wherein the drain trap pipe includes an inlet portion, a trap ascending pipe rising from the inlet portion, and a trap descending pipe dropping from the trap ascending pipe; the jet water spouting port is disposed approximately horizontally, pointing toward the inlet portion of the drain trap pipe; and the pressurizing pump control means controls the rpm of the pressurizing pump so that a first flow volume for generating a siphon action is spouted from the jet water spouting port, then a second flow volume is spouted, generating a flow speed capable of conveying waste, and in such a way as to seal a cross section at some location of the drain trap pipe, thereby continuing the siphon action, prior to the end of the siphon action generated by the first flow volume.

In the first invention of the present invention thus constituted, the jet water spouting port is disposed approximately horizontally, pointing toward the inlet portion of the drain trap pipe; when water is jet spouted, the pressurizing pump rpm is controlled by the pump control means, so that a siphon effect (action) is rapidly induced by spouting of the first flow volume (large flow volume); this quickly discharges accumulated water and waste in the bowl portion; before the siphon action ends, a second flow volume (large flow volume) continues to be spouted, sealing a section of some part of the drain trap pipe, essentially filling the drain trap pipe with water, thereby maintaining the siphon effect (action) continuously (push-out action), such that waste floating in the bowl portion is quickly discharged from the drain trap pipe.

As a result, since jet water spouting is performed using a pressurizing pump in the first invention of the present invention, thereby suddenly inducing a siphon action by jet spouting a large flow volume (the total flow volume of the first flow volume and the second flow volume), the jet spouted flush water volume is reduced and the water conservation requirement is met, and the siphon action is sustained by the push-out action, thus enabling the elimination of the siphon cutoff sound caused by the sucking in of a large volume of air from the drain trap pipe inlet portion at the point when accumulated water in the bowl portion has been discharged by the initial siphon action. Furthermore, because the siphon action is weaker than the initial siphon due to the

push-out action, the siphon cutoff sound can be reduced, since only a weak siphon cutoff sound is generated when this weak siphon action is completed.

0011

5 In the first invention of the present invention, the pump control means preferably controls the pressurizing pump rpm in such a way that the second flow volume is smaller than the first flow volume.

10 In the first invention of the present invention thus constituted, the second flow volume is arranged to be smaller than the first flow volume which induces the siphon effect (action), therefore the siphon effect generated can be continuously maintained at a low flow volume.

0012

15 In the first invention of the present invention, the pressurizing pump control means preferably controls the rpm of the pressurizing pump in such a way that water spouted from the jet water spouting port gradually decreases when spouting of the second flow volume ends.

20 In the first invention of the present invention thus constituted, spouting of water from the jet water spouting port gradually decreases when spouting of the second flow volume ends, therefore the occurrence of a siphon cutoff sound caused by a sudden interruption of the siphon action due to the push-out action can be prevented.

0013

25 In the first invention of the present invention, the first flow volume is preferably 75-120 liters/minute.

0014

In the first invention of the present invention, the flow speed of the flush water spouted from the jet water spouting port by the pressurizing pump under the control of the pump control means is preferably 3.0-6.0 liters/minute.

5 0015

The second invention of the present invention is a flush toilet cleaned by pressurized flush water, said flush toilet comprising a toilet main unit provided with a bowl portion, a rim water spouting port and jet water spouting port for expelling flush water, and a drain trap pipe; a reservoir tank for storing flush water; rim spout water
10 supply means for supplying flush water to the rim water spouting port at a predetermined timing; reservoir water supply means for supplying flush water to the reservoir tank at a predetermined timing; pressurizing means for pressurizing flush water stored in the reservoir tank and supplying the flush water to the jet water spouting port; and
15 pressurizing means control means for controlling the operation of the pressurizing means and controlling the volume pressurized by the pressurizing means so as to control the flow speed and flow volume of flush water spouted from the jet water spouting port; wherein the drain trap pipe includes an inlet portion, a trap ascending pipe rising from the inlet portion, and a trap descending pipe dropping from the trap ascending pipe; the jet water spouting port is disposed approximately horizontally,
20 pointing toward the inlet portion of the drain trap pipe; and the pressurizing means control means controls the volume pressurized by the pressurizing means so that a first flow volume for generating a siphon action is spouted from the jet water spouting port, and a second flow volume, smaller than the first flow volume and generating a flow speed capable at least of conveying waste, is spouted prior to the end of the siphon
25 action generated by the first flow volume.

In the present invention thus constituted, the jet water spouting port is disposed approximately horizontally, directed toward the inlet portion of the drain trap pipe, and when spouting jet water, the volume pressurized by the pressuring means is controlled by the pressurizing means control means; by first spouting a first flow volume (large flow

volume), the siphon effect (action) is rapidly induced, which quickly discharges accumulated water and waste in the bowl portion; next, before the siphon action ends, waste floating in the bowl portion can be rapidly ejected from the drain trap pipe by expelling the second flow volume (large flow volume).

5 As a result, since jet water spouting is performed using the pressurizing pump in the second invention of the present invention, there is little susceptibility to water main pressure, and by rapidly inducing a siphon action by jet spouting a large flow volume (the first flow volume), the jet water spouting flush water volume required to generate a siphon action can be reduced and the requirement for water conservation can be met. In
10 addition, since the second flow volume is made smaller than the first flow volume and floating waste is discharged with the smaller flow volume, water can be saved, and the sound of water being spouted from the jet water spouting port can be reduced, thereby achieving the effect of noise reduction.

15 0016

 In the second invention of the present invention, the pressurizing means control means preferably controls the volume pressurized by the pressurizing means so that before the siphon action ends, a second flow volume is spouted, generating a flow speed at which waste can be conveyed, and also sustaining the siphon action by sealing
20 a section of some part of the drain trap pipe so that the interior of the drain trap pipe is essentially filled with water.

 In the second invention of the present invention thus constituted, a second flow volume (large flow volume) is spouted before the siphon action generated by the first flow volume (large flow volume) ends, thus causing the cross section of some part of the
25 drain trap pipe to be sealed so that the inside of the drain trap pipe is essentially filled with water, continuing and maintaining the siphon effect (action) (the push-out action); by this means, the siphon cutoff sound when the siphon action ends, which is produced by the sucking in of a large volume of air from the drain trap pipe inlet portion when accumulated water in the bowl portion is discharged by the initial siphon action, can be

eliminated, and because the siphon action is weaker than the initial siphon caused by the push-out action, and only this weak siphon cutoff sound is produced when the weak siphon action ends, the siphon cutoff sound can be reduced.

5 0017

In the second invention of the present invention, the pressurizing means control means preferably controls the volume pressurized by the pressurizing means so that before the siphon action ends, a second flow volume is spouted, generating a flow speed capable of conveying waste, and in such a way as to seal a cross section at
10 some location of the drain trap pipe.

In the second invention of the present invention thus constituted, a second flow volume is spouted before the siphon action generated by the first flow volume (large flow volume) ends, thereby sealing a section of some part of the drain trap pipe, so there is no drawing in of a large volume of air from the inlet portion of the drain trap pipe; the
15 siphon cutoff sound at the end of the siphon action, which is generated by the sucking in of a large volume of air from the drain trap pipe inlet portion when accumulated water in the bowl portion is discharged by siphon action, can therefore be suppressed, and a return of foul odors to the drain trap pipe from the downstream side can also be prevented.

20

0018

In the second invention of the present invention, the pressurizing means control means preferably controls the volume pressurized by the pressurizing means so that before the siphon action ends, a second flow volume is spouted, generating a flow
25 speed capable of conveying waste, without sealing a cross section at some location of the drain trap pipe.

In the second invention of the present invention thus constituted, a second flow volume is spouted before the siphon action generated by the first flow volume (large flow volume) ends; the flow of flush water therein permits a reduction in the surface area of

the drain trap pipe inlet portion opening, such that there is no large volume of air drawn in, and the siphon cutoff sound at the end of the siphon action, which is generated by the sucking in of a large volume of air from the drain trap pipe inlet portion when accumulated water in the bowl portion is discharged by siphon action, can therefore be suppressed, and a return of foul odors to the drain trap pipe from the downstream side can also be prevented.

0019

In the second invention of the present invention, wherein the pressurizing means control means preferably controls the volume pressurized by the pressurizing means so that water spouted from the jet water spouting port gradually decreases when spouting of the second flow volume from the jet water spouting port ends.

In the second invention of the present invention thus constituted, spouting from the jet water spouting port is gradually reduced when the spouting of a flow volume for the second flow volume ends, therefore the generation of a siphon cutoff sound occurring when the siphon action is suddenly interrupted can be prevented.

0020

In the second invention of the present invention, the first flow volume is preferably between 75-120 liters/minute.

0021

In the second invention of the present invention, the flow speed of flush water spouted from the jet water spouting port by the pressurizing means under the control of the pressurizing means control means is preferably between 3.0 – 6.2 meters/second.

0022

The third invention of the present invention is a flush toilet cleaned by pressurized flush water, said flush toilet comprising a toilet main unit provided with a bowl portion, a

rim water spouting port and jet water spouting port for expelling flush water, and a drain trap pipe; a reservoir tank for storing flush water; rim spout water supply means for supplying flush water to the rim water spouting port at a predetermined timing; a pressurizing pump for pressurizing flush water stored in the reservoir tank; jet spout water supply means for supplying flush water pressurized by the pressurizing pump to the jet water spouting port at a predetermined timing; and control means for controlling the rim spout water supply means, the pressurizing pump, and the jet spout water supply means to spout flush water to the bowl portion of the toilet main unit; wherein the control means controls the rim spout water supply means, the pressurizing pump, and the jet spout water supply means so that flush water is first spouted from the rim water spouting port and then, as spouting of flush water from the rim water spouting port is continued, a first flow volume generating a siphon action is spouted from the jet water spouting port.

In the present invention thus constituted, when water is jet spouted, a first flow volume generating a siphon action is spouted from the jet water spouting port in a state whereby spouting of flush water from the rim water spouting port is continued, so that by jet water spouting with the level of accumulated water in the bowl portion and in the in the drain trap pipe raised by rim water spouting, a siphon action can be induced in a short period of time, and a strong siphon action can be generated. This enables a reduction in the flush water volume of jet spouting water used to start the siphon action, thus enabling water conservation.

0023

In the third invention of the present invention the jet water spouting port is preferably disposed horizontally, pointing toward the inlet portion of the drain trap pipe.

In the third invention of the present invention thus constituted, because the jet water spouting port is disposed horizontally pointing toward the inlet portion of the drain trap pipe, flush water spouted from the jet water spouting port flows smoothly into the drain trap pipe, and a siphon action can be generated at an early stage.

0024

In the third invention of the present invention, the control means preferably controls the rim spout water supply means, the pressurizing pump, and the jet spout water supply means in such a way that after the first flow volume generating a siphon action is spouted from the jet water spouting port, prior to the end of the siphon action generated by the first flow volume, a second flow volume is spouted which is smaller than the first flow volume and generates at least a flow speed capable of conveying waste.

In the third invention of the present invention thus constituted, waste floating in the bowl portion can be rapidly discharged from a drain trap pipe by spouting a second flow volume, smaller than the first flow volume and generating a flow speed capable of at least conveying waste, prior to the end of the siphon action generated by the first flow volume.

15 0025

In the third invention of the present invention the rim spout water supply means preferably spouts flush water from a rim water spouting port under water main supply pressure.

In the third invention of the present invention thus constituted, it is sufficient for the pressurizing pump to have the capability of supplying the necessary volume of water to the jet water spouting port, therefore the pressurizing pump can be reduced in size, as can the capacity of the reservoir tank.

0026

In the third invention of the present invention the control means preferably causes the pressurizing pump to rotate at a predetermined low speed so as to discharge remaining air within the water supply path connecting the pressurizing pump and the jet water spouting port, prior to spouting the first flow volume of flush water from the jet water spouting port.

In the third invention of the present invention thus constituted, the pressurizing pump is rotated at a predetermined low speed to discharge the remaining air in the supply pipe connecting the pressurizing pump and the jet water spouting port, therefore the sound of air being discharged can be prevented from occurring in the jet water
5 spouting port. Also, since a flow into the drain trap pipe caused by rim water spouting arises at this point, air discharged from the supply pipe flows smoothly into the drain trap pipe, and the exploding air sound arising at the time of discharge into the bowl portion can be suppressed. Additionally, because the pressurizing pump is rotated at the low speed, the accumulated water level resulting from rim water spouting can be kept at a
10 high level, and maintained until the next first flow volume jet water spouting.

0027

In the third invention of the present invention the control means preferably controls the rim water supply means so that when water is spouted from the jet water
15 spouting port, water continues to be spouted from the rim water spouting port.

In the third invention of the present invention thus constituted, water spouting from the rim water spouting port is continued when water is spouted from the jet water spouting port, therefore an influx of air to the inlet portion of the drain trap pipe is impeded, and the siphon cutoff sound can be suppressed. By jet spouting water while
20 gathering floating waste at the center of the accumulated water, adhesion of floating waste to the bowl surface can be prevented and floating waste can be reliably discharged.

0028

In the third invention of the present invention the control means preferably controls the rim spout water supply means, the pressurizing pump, and the jet spout water supply means so that the total of the flow volume spouted from the rim water
25 spouting port and the first flow volume spouted from the jet water spouting port is between 75-120 liters/minute.

0029

In the third invention of the present invention, the flow speed of flush water spouted from the jet water spouting port by the pressurizing pump is preferably between
5 3.0-6.2 meters/second.

0030

The fourth invention of the present invention is a flush toilet cleaned by pressurized flush water, said flush toilet comprising: a toilet main unit provided with a
10 bowl portion, a rim water spouting port and jet water spouting port for expelling flush water, and a drain trap pipe; a reservoir tank for storing flush water; a pressurizing pump for pressurizing flush water stored in the reservoir tank; rim spout water supply means for supplying flush water pressurized by the pressurizing pump to the rim water spouting
15 port at a predetermined timing; jet spout water supply means for supplying flush water pressurized by the pressurizing pump to the jet water spouting port at a predetermined timing; and control means for controlling the rim spout water supply means, the pressurizing pump, and the jet spout water supply means to spout flush water to the bowl portion of the toilet main unit; wherein the control means controls the rim spout
20 water supply means, the pressurizing pump, and the jet spout water supply means so that flush water is first spouted from the rim water spouting port and then, as spouting of flush water from the rim water spouting port is continued, a first flow volume generating a siphon action is spouted from the jet water spouting port.

In the present invention thus constituted, a first flow volume generating a siphon action is spouted from the jet water spouting port as spouting of flush water from the rim
25 water spouting port is continued, therefore by spouting jet water with an elevated accumulated water level in the bowl portion and the drain trap pipe, a siphon action can be induced in a short time period, and a strong siphon action can be generated. This permits a reduction in the flush water volume of that spout water used to induce the siphon effect, thereby achieving water conservation. In addition, because in the present

invention flush water stored in a reservoir tank is pressurized by a pressurizing pump and spouted from a rim water spouting port and a jet water spouting port, flushing of the toilet main unit is not affected by water main pressure.

5 0031

The flush toilet of the present invention is not susceptible to water main pressure, therefore the siphon cutoff sound (noise) generated when the siphon action ends can be reduced, and the requirement for water conservation can be met.

10 0032

In addition, the time up until the siphon action is generated can be reduced in the flush toilet of the present invention, thereby meeting the requirement for water conservation.

15 Brief Description of Drawings

0140

Fig. 1 is a side elevation view showing a flush toilet according to a first embodiment of the present invention.

Fig. 2 is a plan view of the Fig. 1 flush toilet.

20 Fig. 3 is a schematic overview showing a flush toilet according to a first embodiment of the present invention.

Fig. 4 is a timing chart showing the basic operation of a flush toilet according to a first embodiment of the present invention.

25 Fig. 5 is a view explaining the siphon action and push-out action of a flush toilet according to a first embodiment of the present invention.

Fig. 6 is an enlarged view of Fig. 5(e).

Fig. 7 is a schematic overview showing a flush toilet according to a second embodiment of the present invention.

Fig. 8 is a timing chart showing timing examples of rim water spouting (former rim flushing and latter rim flushing), jet water spouting (jet flushing), and tank water supply applicable to a first embodiment and/or a second embodiment of the present invention.

Fig. 9 is a timing chart showing the basic operation of a flush toilet according to a
5 third embodiment of the present invention.

Fig. 10 is a view explaining the siphon action and push-out action of a flush toilet according to a third embodiment of the present invention.

Fig. 11 is a view explaining the siphon action and push-out action of a flush toilet according to a third embodiment of the present invention.

10 Fig. 12 is a timing chart showing the change in pressurizing pump rpm in a flush toilet according to a fourth embodiment of the present invention.

Fig. 13 is a schematic overview showing a flush toilet according to a fifth embodiment of the present invention.

15 Fig. 14 is a timing chart showing the basic operation of a flush toilet according to a fifth embodiment of the present invention.

Best Mode for Carrying Out the Invention

0033

20 Next, referring to the attached drawings, a flush toilet according to an embodiment of the present invention will be described.

First the structure of a flush toilet according to a first embodiment of the present invention will be described with reference to Figs. 1 through 3. Here, Fig. 1 is a side elevation view showing a flush toilet according to the present invention; Fig. 2 is a plan view showing the flush toilet shown in Fig. 1, and Fig. 3 is a schematic overview showing
25 the flush toilet shown in Fig. 1.

0034

As shown in Figs. 1 and 2, the flush toilet 1 according to the first embodiment of the present invention comprises a toilet main unit 2, a toilet seat 4 disposed on the

upper surface of the toilet main unit 2, a cover 6 disposed so as to cover the toilet seat 4, and an outer flushing device 8 disposed at the rear upper portion of the toilet main unit 2. In addition, a functional portion 10 is disposed at the rear of the toilet main unit 2, and the functional portion 10 is covered by side panels 10a.

5

0035

The toilet main unit 2 is ceramic, formed on the toilet main unit 2 are a bowl portion 12 for receiving waste, a drain trap pipe 14 extending from the bottom portion of the bowl portion 12, a jet water spouting port 16 for jet water spouting, and a rim water spouting port 18 for rim water spouting.

10

The jet water spouting port 16 is formed at the bottom of the bowl portion 12, configured to expel flush water toward the inlet to the drain trap pipe 14, and disposed approximately horizontally, pointing toward the inlet of the drain trap pipe 14 so as to expel flush water toward the drain trap pipe 14.

15

The rim water spouting port 18 is formed at the left side upper rear of the bowl portion 12, and expels flush water along the edge of the bowl portion 12.

0036

The drain trap pipe 14 comprises an inlet portion 14a, a trap ascending pipe 14b rising from the inlet portion 14a, and a trap descending pipe 14c dropping from the trap ascending pipe connecting port 14b, between the trap ascending pipe 14b and the trap descending pipe 14c is a peak portion 14d.

20

0037

The flush toilet 1 is directly connected to a water main supplying flush water, flush water is expelled from a rim water spouting port 18 under water main supply pressure. As discussed below, jet water spouting is accomplished by expelling from a jet water spouting port 16 a large volume of flush water stored in a reservoir tank 32 built into a functional portion 10 and pressurized by a pressurizing pump 34.

25

0038

Next the functional portion 10 according to the first embodiment will be described in detail.

5 As shown in Fig. 3, a constant volume valve 20, an electromagnetic valve 22, a rim spout water vacuum breaker 24, and a rim spout water flapper valve 26 are provided on the functional portion 10. In addition, built into a water supply path 19 are a switching valve 28 for switching between supplying the tank and rim water spouting, a reservoir tank 32, a pressurizing pump 34, a jet water spouting vacuum breaker 36, a jet water
10 spouting flapper valve 38, and a water drain plug 39. Also built into the functional portion 10 is a controller 40 for controlling the switching operation of the switching valve 28 and the rpm and operating time, etc. of the pressurizing pump 34.

0039

15 The purpose of the constant volume valve 20 is to constrict to a predetermined flow volume or below the flush water flowing from the water inlet 20a through a stopcock 42a, a strainer 42b, and a splitter hardware 42c. In the present embodiment, the constant volume valve 20 limits the flow volume of flush water to 16 liters/minute or less. Flush water which has passed through the constant volume valve 20 flows into the
20 electromagnetic valve 22, flush water which has passed through the electromagnetic valve 22 is supplied to the rim water spouting port 18 or the reservoir tank 32 by the switching valve 28. This switching valve 28 can supply flush water to both the rim-side water supply path 18a on the rim side and the tank-side water supply path 32a on the tank side at the same timing, and is capable of freely changing the proportion of supply
25 volume to the rim side and the tank side.

0040

The electromagnetic valve 22 is opened and closed by a controller 40 control signal, and serves to allow supplied flush water to flow into the switching valve 28, or to stop that flow.

5 The switching valve 28 is switched by a control signal from the controller 40, flush water flowing in through the electromagnetic valve 22 is expelled from the rim water spouting port 18, or is caused to flow into the reservoir tank 32.

0041

10 The rim spout water vacuum breaker 24 is disposed midway along the rim-side water supply path 18a, which guides flush water which has passed through the switching valve 28 toward the rim water spouting port 18, it functions to prevent flush water back flow from the rim water spouting port 18. The rim spout water vacuum breaker 24 is disposed above the top edge surface of the bowl portion 12, and reliably prevents back flow. In addition, flush water overflowing from the atmosphere opening
15 portion on the rim spout water vacuum breaker 24 flows into the reservoir tank 32 through a return pipe return pipe 24a.

0042

20 The rim spout water flapper valve 26 is disposed on the rim spout water vacuum breaker 24 downstream rim-side water supply path 18a, and prevents back flow of flush water from the rim water spouting port 18. In the present embodiment, flush water back flow is more reliably prevented by connecting the rim spout water vacuum breaker 24 and the rim spout water flapper valve 26 in series to the rim water spouting port 18.

25 0043

The reservoir tank 32 is constituted to store flush water to be spouted from the jet water spouting port 16. Note that in the present embodiment, the reservoir tank 32 has a capacity of appropriate 2.5 liters.

0044

Furthermore, the end (lower end) of the tank-side water supply path 32a is opened at a position above the reservoir tank 32, and prevents back flow from the reservoir tank 32 to the tank-side water supply path 32a. An upper end float switch 32b and a lower end float switch 32c are disposed inside the reservoir tank 32, and detect the water level inside the reservoir tank 32. The upper end float switch 32b turns ON when the water level in the reservoir tank 32 reaches a predetermined stored water level; the tank water supply vacuum breaker 30 senses this and causes the electromagnetic valve 22 to close. The lower end float switch 32c, meanwhile, turns ON when the water level in the reservoir tank 32 drops to a predetermined level; this is sensed by the tank water supply vacuum breaker 30, which stop the pressurizing pump 34.

0045

A covering body 32d is attached to the opening portion at the top end of the upper portion of the reservoir tank 32, creating a water tight seal between the exterior perimeter of the covering body 32d and the inner wall surface of the upper portion of the reservoir tank 32. Furthermore, a cylinder body 32e is attached in an upwardly extending manner to a wall surface 32g above the reservoir tank 32 covering body 32d so as to surround a circular hole provided in the covering body 32d.

0046

The reservoir tank 32 wall surface 32g extends to a point above the covering body 32d, and flush water overflowing from the reservoir tank 32 cylinder body 32e collects on top of the covering body 32d. A drain path 32f is connected to the wall surface 32g, which is above the reservoir tank 32 covering body 32d, so that flush water collected over the covering body 32d can be drained into the bowl portion 12.

0047

The pressurizing pump 34 pressurizes flush water stored in the reservoir tank 32, causing it to be expelled from the jet water spouting port 16. The pressurizing pump 34 is connected by a flush water pipe 34a extending from the bottom portion of the reservoir tank 32, and serves to pressurize the flush water stored in the reservoir tank 32.

5 Note that in the present embodiment the pressurizing pump 34 pressurizes the flush water in the reservoir tank 32, causing the flush water to be expelled from the jet water spouting port 16 at a maximum flow volume of appropriate 120 liters/minute.

0048

10 A jet water spouting flapper valve 38, which serves as a check valve, and a water drain plug 39 are provided midway along the flush water pipe 34a. This jet water spouting flapper valve 38 and water drain plug 39 are disposed at a height in the vicinity of the lower end portion of the reservoir tank 32, below the pressurizing pump 34. Therefore flush water in the reservoir tank 32 and the pressurizing pump 34 can be

15 drained for maintenance or the like by opening the water drain plug 39. By disposing a jet water spouting flapper valve 38 between the reservoir tank 32 and the pressurizing pump 34, flush water can be prevented from flowing back from the pressurizing pump 34 into the reservoir tank 32 when the water level in the reservoir tank 32 becomes lower than the height of the pressurizing pump 34, emptying the pressurizing pump 34 of flush

20 water.

0049

At the same time, the outflow port on the pressurizing pump 34 is connected to the jet water spouting port 16 at the bottom portion of the bowl portion 12 through a flush

25 water pipe 34b. A protruding shape is formed midway along the flush water pipe 34b, and a flush water pipe peak portion 44, which is the highest part of this protrusion, is the highest part of the flush water pipe from the reservoir tank 32 to the jet water spouting port 16.

0050

The jet water spouting vacuum breaker 36 is connected to a branching pipe 36a which branches off from the downstream side of the pressurizing pump 34 and the flush water pipe peak portion 44, in addition to preventing back flow of accumulated water in the bowl portion 12 to the reservoir tank 32 side, this forms a partition between those elements. Flush water overflowing from the atmosphere opening portion of the jet water spouting vacuum breaker 36 flows through a return pipe 36b into the reservoir tank 32.

0051

The controller 40, through operation by the operator of a toilet flushing switch (not shown), sequentially activates the electromagnetic valve 22, the switching valve 28, and the pressurizing pump 34, and sequentially starts the spouting of water from the rim water spouting port 18 and the jet water spouting port 16, flushing the bowl portion 12. Furthermore, the controller 40 releases the electromagnetic valve 22 after flushing is completed, switching the switching valve 28 over to the reservoir tank 32 side and replenishing flush water to the reservoir tank 32. When the water level in the reservoir tank 32 rises and a predetermined stored water volume is detected by the upper end float switch 32b, the controller 40 closes the electromagnetic valve 22 and stops supplying water.

20

0052

Next, the operation of the flush toilet 1 will be described. First, the basic operation of a flush toilet 1 will be explained with reference to Fig. 4.

As shown in Fig. 4, in the standby state (time t_0 - t_1), the first rim water spouting (pre-rim flush) is commenced when the flush toilet switch (not shown) is operated (time t_1). That is, when the user operates the toilet flushing switch (not shown), a signal is sent to the electromagnetic valve 22 to open, the switching valve 28 is switched over to the rim water spouting port 18 side, and flush water from the rim water spouting port 18 is expelled by water main pressure. When the electromagnetic valve 22 is released,

flush water supplied from the water main flows into the constant volume valve 20 from the water inlet 20a through the stopcock 42a, the strainer 42b, and the splitter hardware 42c. In the constant volume valve 20, the flow volume of flush water passing through is restricted when the water main supply pressure is high, and flush water passes through
5 as is without being restricted when the water main supply pressure is low. Flush water which has passed through the constant volume valve 20 then passes through the electromagnetic valve 22 and the switching valve 28, the rim spout water vacuum breaker 24, the rim spout water flapper valve 26, and the rim-side water supply path 18a, and is expelled from the rim water spouting port 18 opened on the rear left side of the
10 upper portion of the bowl portion 12. Flush water expelled from the rim water spouting port 18 flows downward as it swirls within the bowl portion 12, thereby flushing the inner wall surface of the bowl portion 12.

0053

15 Thereafter (time t_2), jet water spouting is commenced, while at the same time replenishment of flush water to the reservoir tank 32 is also commenced.

 First, the controller 40 sends a signal to the pressurizing pump 34 to start up, holding the pump rpm at N_1 . When the pressurizing pump 34 is started, flush water which had been stored in the reservoir tank 32 flows through the jet water spouting
20 flapper valve 38 and the water drain plug 39 into the pressurizing pump 34 and is pressurized. Flush water pressurized by the pressurizing pump 34 passes through the flush water pipe 34b flush water pipe peak portion 44 and is expelled from the jet water spouting port 16 opened at the bottom portion of the bowl portion 12.

 At this point, air accumulated in the vicinity of the flush water pipe 34b flush water
25 pipe peak portion 44 passes through the branching pipe 36a and reaches the jet water spouting vacuum breaker 36, where it is released from the air release portion.

0054

Flush water expelled from the jet water spouting port 16 flows into the drain trap pipe 14, filling the drain trap pipe 14 and inducing a siphon effect. This siphon effect causes the accumulated water and waste in the bowl portion 12 to be sucked into the drain trap pipe 14 and discharged from the drain pipe D. In the present embodiment the
5 pressurizing pump 34 is first rotated at a pump rpm of N1 (time t2-t3), and can expel flush water from the jet water spouting port 16 at a high flow volume of between 75 liters/minute-120 liters/minute as the pressurizing force increases, by this means a siphon effect within the drain trap pipe 14 is suddenly induced, and accumulated water and waste in the bowl portion 12 is quickly discharged.

10

0055

Thereafter (time t3), the pressurizing force is slightly reduced by reducing the pump rpm down to N2, and flush water continues to be expelled from the jet water spouting port 16 at a large flow volume of less than 60 liters/minute-120 liters/minute
15 (corresponding to the "first pattern" by "second flow volume" in the third embodiment discussed below). This allows the siphon action generated by the large flow volume of flush water expelled at a pump rpm of N2 by the "push-out action" discussed below to be continued even longer, thereby enabling the quick discharge of floating waste remaining in the bowl portion.

20

Moreover, the pump rpm N2 achieves the flow speed value necessary for the jet water spout to convey waste to the drain trap pipe 14 peak portion 14d (3.0 meter/second-6.2 meters/second).

0056

25

Note that in the present embodiment, as shown by the dotted line in Fig. 4, the pump rpm can also be held as is at N1, without a reduction to N2 (time t3-t4).

0057

In addition, in the present embodiment the pressurizing pump rpm is controlled so that spouting of water from the jet water spouting port is gradually decreased when jet water spouting at pump rpm N2 ends (time t4-45).

This enables the prevention of a large siphon cutoff sound caused by a sudden
5 interruption of the siphon action.

0058

When the pressurizing pump 34 is thus operated for a predetermined time (time
t2-t5), flush water is spouted from the jet water spouting port 16 and the volume of
10 stored water in the reservoir tank 32 goes to approximately 0. Spouting from the jet
water spouting port 16 is stopped when the pressurizing pump 34 is stopped (time t5).
Atmospheric air is thus introduced from the jet water spouting vacuum breaker 36 into
the flush water pipe, and flush water is partitioned between the bowl portion 12 and the
reservoir tank 32.

15

0059

In the first embodiment, replenishment of the reservoir tank 32 occurs
simultaneously during the period of jet water spouting (time t2-t5). At this point the
controller 40, while maintaining the electromagnetic valve 22 in a released state, sends
20 a signal to the switchover valve 28, switching this over to the tank side. Since the
electromagnetic valve 22 is released, flush water flowing in from the water inlet 20a
passes through the constant volume valve 20, the electromagnetic valve 22, the
switching valve 28, and the tank-side water supply path 32a, flowing into the reservoir
tank 32 from the end of the tank-side water supply path 32a.

25

0060

Next, when spouting ends (time t5), the controller 40 sends a signal to the
electromagnetic valve 22 releasing it and commencing the second water spouting from
the rim water spouting port 18 (latter rim flush). The level of accumulated water in the

bowl portion 12 rises to due to the second spouting from the rim water spouting port 18, and the inside of the bowl portion 12 reaches a predetermined accumulated water level after a predetermined rim water spouting time has elapsed (time t_6).

5 0061

After the second rim water spouting has ended (time t_6), flush water is again replenished to the reservoir tank 32. At this point, as described above, the controller 40, with electromagnetic valve 22 in a released state, sends a signal to the switching valve 28, switching this to the tank side so that the flush water flows into the reservoir tank 32.

10

0062

When flush water is replenished into the reservoir tank 32 and the water level in the reservoir tank 32 reaches a predetermined stored water level, the float switch 32b turns ON. When the float switch 32b turns ON, the controller 40 sends a signal to the electromagnetic valve 22 to close.

15

The values for the times t_1 - t_7 shown in Fig. 4, as shown in Fig. 8(a) explained below, are preferably $t = 0$ sec, t_1 - $t_2 = 8$ sec, t_2 - $t_5 = 2.9$ sec, t_5 - $t_6 = 5.5$ sec, and t_6 - $t_7 = 13.1$ sec.

20 0063

Next, details of the siphon action and the push-out action in a flush toilet according to the present embodiment will be explained with reference to Figs. 5 and 6. Fig. 5 explains the flushing mechanism when jet water spouting, which is to say the siphon action and the push-out action. Fig. 6 is an enlarged view of Fig. 5(e).

25

Fig. 5(a) shows the standby state (time t_0 - t_1 in Fig. 4), this is the state whereby water is accumulated in the bowl portion. Next, after going through rim water spouting, jet water spouting is commenced as shown in Fig. 5(b) (time t_2 in Fig. 4), at which point the pump rotates at an rpm of N_1 , and the drain trap pipe is filled with water by a large

flow volume jet flow. Next, as shown in Fig. 5(c), air is drawn in from the drain trap pipe inlet portion, triggering the end of the siphon action (time t3-t4 in Fig. 4).

0064

5 However, in the present embodiment, a large flow volume of jet water spouting continues to be supplied thereafter (t3-t4 in Fig. 4), so the volume of air drawn in from the drain trap pipe is small, as shown in Fig. 5(d). Moreover, even after air is drawn into the drain trap pipe, a large flow volume of jet spout water continues to be supplied (times t3-t4 in Fig. 4), therefore the jet spa water collides with the bottom wall surface of
10 the drain trap pipe 14 inlet portion 14a as shown in Fig. 5(e) and Fig. 6, generating a swirling flow within the trap ascending pipe connecting port 14b. As a result of this swirling flow, the inlet portion 14a is sealed in section, and the inside of the inlet portion 14a and the trap ascending pipe 14b are essentially in a full state. This results in a continuation of the site connection. In other words, in the state depicted in Fig. 5(e) and
15 Fig. 6 (time t3-t4 in Fig. 4), a push-out action is generated by the jet water spouting of a large flow volume supplied continuously while the previously occurring siphon action is maintained. Waste floating in the bowl portion is quickly discharged from the drain trap pipe by this push-out action.

20 0065

Note that in the present embodiment, as shown in Fig. 6, a section of the drain trap pipe 14 inlet portion 14a is sealed, but the siphon action could also be maintained by sealing a section in any other part of the drain trap pipe 14 to essentially fill the drain trap pipe.

25

0066

Thereafter, as shown in Fig. 5(f), the volume of flush water for jet spouting is gradually decreased (time t4-t5 in Fig. 4), thereby preventing the occurrence of a siphon cutoff sound, and the discharge of waste is quietly completed. Next, as shown in Fig.

5(g), rim water spouting (latter rim flushing) is started (time t_5 in Fig. 4) following which, as shown in Fig. 5(h), the toilet returns to the original standby state (after time t_6 in Fig. 4).

5 0067

As explained above, in the first embodiment of the present invention the jet water spouting port 16 is disposed approximately horizontally, pointing toward the inlet portion of the drain trap pipe 14. When jet water spouting, the pressurizing pump 34 is first rotated at an rpm N_1 to supply a large flow volume of jet spouted water to a drain trap pipe, thereby rapidly inducing a siphon effect (action), by which accumulated water and waste in the bowl portion 12 is quickly discharged. Next, the pressurizing pump 34 is rotated at an rpm N_2 to continue supplying a large volume of jet spout water, at this point the jet spout water collides with the lower wall surface of the drain trap pipe 14 inlet portion 14a and a swirl current is generated within the trap ascending pipe connecting port 14b so that the interior of the inlet portion 14a and the trap ascending pipe connecting port 14b becomes essentially full of water, such that a section in one of those parts is sealed (push-out action). By thus rotating the pressurizing pump 34 at an rpm of N_2 to continue to supply a large flow volume of jet spout water (push-out action) the siphon effect (action) can be maintained, and by this push-out action waste floating in the bowl portion can be quickly discharged from the drain trap pipe 14.

0068

As result, according to the first embodiment of the present invention jet water spouting is performed using the pressurizing pump 34, therefore susceptibility to the effects of water main pressure is low, and by jet water spouting a large flow volume (the flow volume using the pressurizing pump at the N_1 and N_2 rpms), the volume of jet spouted flush water is reduced, the requirement for water conservation is met, and the siphon effect is maintained by the push-out effect, so that at the point when accumulated water in the bowl portion 12 is discharged by the initial siphon action, the siphon cutoff

sound at the end of the siphon effect generated by the drawing in of a large volume of air from the drain trap pipe 14 inlet portion 14a can be eliminated, and because the siphon action is weaker due to the push-out effect than at the initial siphon, only a weak siphon cutoff sound is generated at the end of this week siphoning, therefore the siphon cutoff sound can be reduced.

0069

Next, referring to Fig. 7, a flush toilet based on a second embodiment of the present invention will be described. Only the portions of the second embodiment differing from the first embodiment will be explained. As shown in Fig. 7, in this second embodiment, a rim water spouting electromagnetic valve 23 and a electromagnetic valve 25 are provided in place of the electromagnetic valve 22 and the switching valve 28 of the first embodiment. Specifically, the rim water spouting electromagnetic valve 23 is provided on the downstream side of the constant volume valve 20, and is connected to the rim-side water supply path 18a. The tank water supply electromagnetic valve 25 is provided on the downstream side of the constant volume valve 20, and is connected to the tank-side water supply path 32a.

0070

Opening and closing (turning ON and OFF) of the rim water spouting electromagnetic valve 23 and the tank water supply electromagnetic valve 25 is accomplished using a control signal from the controller 40.

In the flush toilet according to the second embodiment, the rim water spouting electromagnetic valve 23 and the tank water supply electromagnetic valve 25 can be independently opened and closed, therefore as discussed below, rim water spouting and tank water supply can be carried out at the same timing.

0071

Next, referring to Fig. 8, examples of timing for applicable rim water spouting (former rim flush and latter rim flush), jet water spouting (jet flush), and tank water supply in the first and second embodiments of the present invention will be explained (Ex. 1 through Ex. 5).

5 Fig. 8 shows the following examples, respectively: Ex. 1 in Fig. 8(a), Ex. 2 in Fig. 8(b), Ex. 3 in Fig. 8(c), Ex. 4 in Fig. 8(d), Ex. 5 in Fig. 8(e).

0072

10 First, Ex. 1 in Fig. 8(a) is the same as what is shown in Fig. 4. In Ex. 1, former rim flushing is first performed for eight seconds, jet flushing is then performed for 2.9 seconds while supplying water to the tank is simultaneously performed for 2.9 seconds. Rim flushing is then performed for 5.5 seconds. Finally, water is supplied to the tank for 13.1 seconds.

15 In Ex. 1, supplying of chase water to the tank is carried out while the pressurizing pump is operating, thereby permitting the flow volume of jet spout water to be maximized. Also, because the latter rim flush and the supply of water to the tank are carried out independently, flush water in the latter rim flush goes around the bowl portion and can thereby increase the flushing effect.

20 0073

Next, in Ex. 2 in Fig. 8(b), the former rim flush is first carried out for 8 seconds continuously, then the latter rim flush is carried out for 5.5 seconds. A jet flush is carried out for 2.9 seconds, and water is simultaneously supplied to the tank for 2.9 seconds prior to the end of the former rim flush. Thereafter, following the latter rim flush, water is
25 supplied to the tank for 13.1 seconds. In this Ex. 2 the latter rim flush is carried out in continuation following the former rim flush, thereby facilitating easy control of the rim flush. Also, because the chase water is supplied to the tank while the pressurizing pump is operating, the flow volume of jet spout water can be maximized.

0074

Next, in Ex. 3 of Fig. 8(c), a latter rim flush is carried out for 24 seconds in continuation after a former rim flush is carried out for 8 seconds. Also, jet flushing is performed for 2.9 seconds prior to the end of the former rim flush. Thereafter, following the commencement of the latter rim flush, water is supplied to the tank for 21 seconds, and the latter rim flush and supplying of water to the tank end simultaneously.

In Ex. 3 the latter rim flush and the supplying of water to the tank end simultaneously, therefore the user can be made aware that the tank is being supplied with water while the bowl portion is being refilled with flush water.

0075

Next, in Ex. 4 of Fig. 8(d), a former rim flush is carried out for 8 seconds, a jet flush is then carried out for 2.9 seconds, and a latter rim flush is then carried out for 24 seconds. Supplying of water to the tank, on the other hand, starts simultaneously with the jet flush and is performed for 21 seconds, ending before the latter rim flush.

In Ex. 4, higher priority is given to supplying tank water than to the latter rim flush, therefore the tank can be reliably supplied with water.

20

0076

Next, in Ex. 5 of Fig. 8(e), a latter rim flush is carried out for 24 seconds in continuation after a former rim flush is carried out for 8 seconds. Also, jet flushing is performed for 2 seconds prior to the end of the former rim flush. Thereafter, the tank is immediately supplied with water for 21 seconds.

In Ex. 5, the latter rim flush is carried out in continuation following the former rim flush, therefore rim flushing can be easily controlled. Since higher priority is given to supplying tank water than to the latter rim flush, the tank can be reliably supplied with water.

0077

Next, a flush toilet according to a third embodiment of the present invention will be described, referring to Figs. 9 through 11. Fig. 9 is a timing chart showing the basic operation of a flush toilet according to a third embodiment of the present invention; Figs. 10 and 11 are views explaining the siphon action in the jet of water spouting state in a flush toilet according to a third embodiment of the present invention.

The structure of the flush toilet in this third embodiment is the same as that of the flush toilet shown in Figs. 3 and 7, so for convenience, basic operation of the flush toilet having a structure shown in Fig. 3 will be explained using Fig. 9.

0078

As shown in Fig. 9, in the standby state (time t_0 - t_1) the switching valve 28 is first in a neutral position communicating with both the rim-side water supply path 18a and the tank-side water supply path 32a. Next, when a toilet flushing switch (not shown) is operated (time t_1) in this standby state (time t_0 - t_1), former rim water spouting is commenced (time t_1 - t_{11}). At this point the switching valve 28 is first placed in a state whereby it is fully open to the tank-side water supply path 32a during the time t_2 - t_3 (the tank side fully open position). Simultaneously (time t_2), the electromagnetic valve 22 is turned ON and flush water is caused to flow into the water supply path 19. This enables air remaining within the water supply path 19 on the upstream side of the switching valve 28 to be discharged into the reservoir tank 32. As a result, the air discharge sound from the rim water spouting port 18 arising when the switching valve 28 is suddenly switched to the rim-side water supply path 18a, which is the rim side, can be prevented.

25

0079

Next, between times t_3 - t_4 the switching valve 28 is switched from the tank-side fully open position to the rim-side fully open position, flush water is supplied to the rim water spouting port 18, and flush water is spouted from the rim water spouting port 18.

0080

Next, after a predetermined time (e.g. 5 seconds) has elapsed from time t_2 , jet water is spouted in the interval between times t_5 - t_{11} by turning ON the pressurizing pump 34 and using the pressurizing pump 34 to supply flush water in the reservoir tank 32 to the jet water spouting port 16, thereby spouting flush water from the jet water spouting port 16.

0081

Here, at time t_5 , when jet water spouting is commenced by the pressurizing pump 34, rim spouting is carried out continuously. Moreover, this rim spouting continues without interruption from the beginning until the end of the jet water spouting.

0082

In the present embodiment, rim water spouting is being carried out continuously when jet water spouting is started, i.e., jet water spouting is carried out with an elevated level of accumulated water in the bowl portion 12 and the drain trap pipe 14 due to rim water spouting, therefore a siphon effect can be induced in a short period of time, and a strong siphon effect can be generated. As a result, the volume of jet water spouting flush water for starting the siphon action can be reduced, thus achieving water conservation.

0083

Furthermore, in the present invention rim water spouting is continued without interruption from the start until the end of jet water spouting (times t_5 - t_{11}), making it difficult for air to flow into the inlet portion of the drain trap pipe, and thus suppressing the siphon cutoff sound.

0084

Next, the controller 40 controls the rpm of the pressurizing pump 34 as follows while this jet spouting is going on.

5 First, at time t6-t7, the pressurizing pump 34 is kept at a relatively slow speed (e.g., 1000 rpm), by which means air remaining in the vicinity of the flush water pipe 34b peak portion 44 (i.e., the portion positioned above the accumulated water surface of the bowl portion 12) is discharged from the jet water spouting port 16. As a result, the sound of air being discharged from the jet water spouting port 16, which is generated when the pressurizing pump 34 is suddenly started at its originally intended high rotation speed, can be prevented.

10

0085

Next, at time t8-t9, the pressurizing pump 34 is rotated at a high speed (e.g., 3500 rpm). This causes the pressurizing force of the pressurizing pump 34 to increase, so that a large flow volume of flush water is spouted from the jet water spouting port 16. 15 At this point, rim water is being continuously spouted from the rim water spouting port 18, therefore the flow volume of flush water spouted from the rim water spouting port 18 is added thereto, and a large flow volume of flush water flows into the drain trap pipe 14 inlet portion 14a, such that a siphon effect is rapidly induced, and accumulated water and waste in the bowl portion 12 is quickly discharged. At this point the flow volume 20 flowing into the drain trap pipe 14 inlet portion 14a is less than a total of 75 liters/minute – 120 liters/minute for the flow volume coming from the rim water spouting (10 liters/minute – 15 liters/minute) and from the jet spout water (the first flow volume), which is a large flow volume compared to conventional examples.

25 0086

Next, at time t9-t11, the flow volume of flush water flowing into the drain trap pipe 14 inlet portion 14a (the second flow volume) is set to be a smaller flow volume than the flow volume above (the first flow volume), therefore the pressurizing pump 34 rpm is slightly decreased. In this Fig. 9 example, the rpm of the pressurizing pump 34 is

reduced in two stages (e.g., 3300 rpm and 3200 rpm) in order to cause the second flow volume to flow into the drain trap pipe 14 inlet portion 14a. At this point the pressurizing pump 34 rpm may have just one stage, without variation, or may be reduced in three or more stages.

5

0087

Thus, in the present embodiment, a second flow volume of flush water, smaller than the first flow volume, is caused to flow into the drain trap pipe 14 inlet portion 14a immediately before the siphon effect generated by the first flow volume ends (time t9).

10

0088

In the third embodiment, the second flow volume is at least sufficient to generate a flow speed such that waste in the bowl portion 12 can be conveyed to pass over the drain trap pipe 14 peak portion 14d, the flow volume can be adjusted within the range over which waste can be conveyed from the bowl portion 12. By making the second flow volume smaller than first flow volume, waste floating in the bowl portion 12 can be discharged with a small flow volume, thereby conserving water and reducing noise by lowering the sound of water spouting from the jet water spouting port 16. Moreover, the inertial force of the pressurizing pump 34 is reduced by lowering the rpm of the pressurizing pump 34, reducing the pressurizing pump 34 inertial force means that a smaller amount of flush water is sufficient to be drawn in from the reservoir tank 32, so that even though the size of the reservoir tank 32 is made smaller, sucking in of air by the pressurizing pump 34 in what is known "air cavitation" can be prevented.

25 0089

Adjusting the second flow volume to various values enables the execution of a first pattern, a second pattern, and/or a third pattern.

0090

That is, the first pattern is the same as the state shown in Fig. 5(e) and Fig. 6 in the first embodiment described above, wherein the siphon action can be continued by arranging for the flow volume of flush water flowing into the drain trap pipe 14 (the second flow volume) to generate a flow speed capable of conveying waste and of sealing a section in some part of the drain trap pipe 14, essentially filling the drain trap pipe 14 with water. At this point, the pressurizing pump 34 rpm for generating the second flow volume in time t9-t11 is the first stage 3300 rpm (time t9-t11). Note that as shown in Fig. 9, at time t9-t11, the second stage 3300 rpm (time t9-t10) (corresponding to the first pattern state) and 3200 (time t9-t10) (corresponding to the second pattern described below) may also be used.

0091

Next, as shown in Fig. 10(e) described below, the flow volume of flush water flowing into the drain trap pipe 14 (the second flow volume) generates a flow speed capable of conveying waste and of sealing a section in some part of the drain trap pipe 14 in which the siphon action has ceased. At this point, the pressurizing pump 34 rpm for generating the second flow volume in time t9-t11 is at the first stage 2800 rpm (time t9-t11). Note that as shown in Fig. 9, in time t9-t11, the second stage 2800 rpm (time t9-t10) (corresponding to the second pattern state) and 2600 (time t9-t10) (corresponding to the third pattern described below) may also be used.

0092

Note that at time t8-t9 in Fig. 9, the rpm of the pressurizing pump 34 for generating the first flow volume to induce a siphon effect may also be lowered to 2800 rpm, for example, thus reducing the volume of flush water use. In this case the flow volume (second pattern) would be of the order necessary to seal a section of some part of the drain trap pipe 14 after time t9, but since water is accumulated in the old portion 12, a siphon effect can be induced even at this low rpm. However the siphon suction force on waste is weak, so this is preferably used for flushing after small-flush use.

0093

In the third pattern, moreover, the state shown in Fig. 11(e) and described below is achieved, whereby the flow volume of flush water flowing in the drain trap pipe 14 (the
5 second flow volume) generates a flow speed capable of conveying waste without sealing a section of the drain trap pipe 14. At this point the pressurizing pump 34 rpm for generating a second flow volume at time t9-t11 in Fig. 9 is the first stage 2600 rpm (time t9-t11).

10 0094

Next, at time t11, when the level of flush water in the reservoir tank 32 drops and the bottom end float switch 32c turns ON, operation of the pressurizing pump 34 stops. At this point the pressurizing pump 34 rpm is slowly reduced during the interval between t11 and t12 so that the spouting of water from the jet water spouting port 16 is gradually
15 reduced. This enables the prevention of a siphon cutoff sound arising when there is a sudden interruption in the siphon action (especially in the first pattern).

0095

At time t11 jet water spouting has ended, but at this point rim water spouting
20 continues as it was, and during a predetermined period from time t11 to time t13 (e.g. 4 seconds), only rim water spouting (latter rim water spouting) is continued.

Subsequently, at time t13-t14, the switching valve 28 is switched from rim-side fully open to tank-side fully open. Flush water is thus stored in the reservoir tank 32.

Next, at time t15, the top end float switch 32b turns ON due to the rise in water
25 level in the reservoir tank 32, which turns OFF the electromagnetic valve 22 (a closing operation) such that the inflow of flush water to the reservoir tank 32 is stopped.

0096

Next, at time t16, the switching valve 28 returns to the neutral position at which it communicates with both the rim side and the tank side, and is restored to the standby state (the same state as at time t0).

5 0097

Next, referring to Fig. 10, a second pattern will be explained, wherein the second flow volume described above is caused to flow into the drain trap pipe 14 inlet portion 14a.

10 In this second pattern, the pressurizing pump 34 rpm during time t9-t11 in Fig. 9 is reduced to less than that used in the first pattern, flush water is jet water spouted from the jet water spouting port 16; the rim water spouting flow volume is added thereto, and a second flow volume is caused to flow into the drain trap pipe 14 inlet portion 14a.

0098

15 Among the states shown in Figs. 10(a)-(h) for this second pattern, only the states shown in Fig. 10(e) and (f) differ from the states shown in Fig. 5 (e) and (f) for the first pattern, others are the same.

20 That is, in the second pattern, during time t9-t10 shown in Fig. 9, a relatively large volume of flush water is continuously expelled from the jet water spouting port 16 even when air is drawn into the drain trap pipe 14, therefore this jet water spouting seals a section of the drain trap pipe 14 inlet portion 14a. Note that in the second pattern there is a slight decrease in the flow volume supply compared to the first pattern, therefore air penetrates into the drain trap pipe 14 from the drain pipe D side, at which point the siphon action ends.

25

0099

Thus, in the second pattern, some portion of the drain trap pipe 14 (the inlet portion 14a or the like) is sealed, so there is no drawing in of large volumes of air in clumps from the drain trap pipe 14 inlet portion 14a, as a result of which the siphon

cutoff sound at the time the siphon action ends, which is generated by the drawing in of large volumes of air from the drain trap pipe 14 inlet portion 14a upon the discharge of accumulated water in the bowl portion 12 by siphon action, can be suppressed, and the return of foul smells from the drain pipe D can also be prevented. In addition, the jet water spouting of a relatively large flow volume from the jet water spouting port 16 enables flush water to pass over the drain trap pipe 14 peak portion 14d, as a result of which waste floating in the bowl portion can be discharged from the drain trap pipe 14.

0100

10 Next, referring to Fig. 11, a third pattern will be explained, wherein the above-described second flow volume is caused to flow into the drain trap pipe 14 inlet portion 14a.

15 In this third pattern, the rpm of the pressurizing pump 34 during time t9-t11 is further reduced below that of the second pattern, flush water is jet spouted from the jet water spouting port 16, a flow volume caused by rim water spouting is added thereto, and the second flow volume is caused to flow into the drain trap pipe 14 inlet portion 14a.

0101

20 Among the states shown in Figs. 11(a)-(h) for this second pattern, only the states shown in Fig. 11(e) and (f) differ from the states shown in Fig. 5 (e) and (f) for the first pattern, others are the same.

0102

25 That is, as shown in Fig. 11(d), at time t9-t10 in Fig. 9 air is drawn into the drain trap pipe and siphon action ends, but a relatively large flow volume of flush water is still being spouted from the jet water spouting port 16, so the flow of that flush water allows the opening surface area of the drain trap pipe 14 inlet portion 14a to be reduced such that there is not a large volume of air drawn in from that point, as a result of which the siphon cutoff sound at the time the siphon action ends, which is generated by the

drawing in of large volumes of air from the drain trap pipe 14 inlet portion 14a upon the discharge of accumulated water in the bowl portion 12 by siphon action, can be suppressed, and the return of foul smells from the drain pipe D can also be prevented. Moreover, flush water can pass over the drain trap pipe 14 peak portion 14d, as a result
5 of which waste floating in the bowl portion can be discharged from the drain trap pipe 14.

0103

Next, referring to Fig. 12, a flush toilet according to a fourth embodiment of the present invention will be explained. Fig. 12 is a time chart showing changes in
10 pressurizing pump rpm in a flush toilet according to the fourth embodiment of the present invention. In this fourth embodiment, pressurizing pump 34 rpm differs from that of the third embodiment described above with respect to only time t9-t11 in Fig. 9; other parts are the same as the third embodiment.

15 0104

In this fourth embodiment, as shown in Fig. 12, the rpm of the pressurizing pump 34 is increased up to 3500 rpm at time t7, next, at time t9, the rpm of the pressurizing pump 34 is decreased from 3500 rpm to 2800 rpm (the jet water spouting state at time t9-t10 is the same as in the above described third pattern). By thus reducing rpm, the
20 instantaneous water spouting volume can be decreased to conserve water. Next, at time t10, the rpm of the pressurizing pump 34 is increased to 3300 rpm (the jet water spouting state at time t10-t11 is the same as the above described first pattern). By thus creating a strong blow zone through the increase in jet water spouting volume, waste (especially waste floating in the accumulated water remaining after siphoning has been
25 generated) can be discharged from the trap ascending pipe connecting port 14b, thereby increasing flushing power.

0105

In the embodiment described above, the pressurizing pump used is one in which rpm is varied to adjust flow volume, but an accumulator tank in combination with a flow control valve, for example, could also be used as a pressurizing means other than this pressurizing pump. In this example the reservoir water tank comprises an accumulator tank, the flow volume of flush water supplied under pressure by that accumulator tank could be controlled by a proportional electromagnetic valve type of flow control valve to achieve spouting from a jet water spouting port.

0106

10 Next, referring to Figs. 13 and 14, a flush toilet according to a fifth embodiment of the present invention will be explained. Fig. 13 is a schematic overview showing a flush toilet according to a fifth embodiment of the present invention, Fig. 14 is a timing chart showing the basic operation of a flush toilet according to a fifth embodiment of the present invention.

15 Note that the basic structure of the flush toilet in the fifth embodiment is the same as that shown in Fig. 1 and Fig. 3, therefore an explanation thereof is omitted.

0107

20 Next, referring to Fig. 13, details of the functional portion 10 of the flush toilet 1 of the present embodiment will be explained.

As shown in Fig. 13, a supply path 124, over which flush water is supplied from a water main, is provided on the functional portion 10, and a stopcock 126, a strainer 128, a splitter hardware 130, a constant flow valve 132, and starting from the upstream side, a diaphragm type electromagnetic on/off valve 134 are respectively provided on a supply path 124.

0108

As described below, the constant flow valve 132, the electromagnetic on/off valve 134, and the vacuum breakers 142, 148 described below are integrated into a single valve unit 137.

5 The supply path 124 downstream side 124a is connected to a reservoir tank 120, and supplies flush water to the reservoir tank 120.

0109

10 Here the purpose of the constant flow valve 132 is to restrict flush water flowing in through the stopcock 126, the strainer 128, and the splitter hardware 130 to being less than a predetermined flow volume. Flush water which has passed through the constant flow valve 132 flows into the electromagnetic on/off valve 134, and flush water which has passed through the electromagnetic on/off valve 134 is supplied to the reservoir tank 120 by the supply path 124.

15 0110

A pump-side supply path 145 is connected to the lower portion of the reservoir tank 120, and a pressurizing pump 122 provided with a pump chamber 122a is connected to the downstream end of this pump-side supply path 145. Furthermore, the pressurizing pump 122 and the jet water spouting port 16 are connected via the jet-side water supply path 146, and the pressurizing pump 122 pressurizes flush water stored in the reservoir tank 120 so that it is supplied up to the jet water spouting port 16.

0111

25 The jet-side water supply path 146, as shown in Fig. 13, is formed with a convex upward-pointing shape, and the peak portion 146a of this convex portion is at the highest position.

0112

A water supply line switching valve 136 is attached to this jet-side water supply path 146. In addition, a rim-side water supply path 138 for supplying flush water to the rim water spouting port 18 is provided on the water supply line switching valve 136 so as to branch off from the jet-side water supply path 146. This water supply line switching valve 136 can supply flush water to both the rim-side water supply path 138 and the jet-side water supply path 146 at the same timing, making the proportion of supplied water volume optionally variable to the rim side and the tank side.

0113

10 Next, a rim water spouting vacuum breaker 148 is provided on the above-described rim-side water supply path 138, and enabling the prevention of flush water back flow from the rim water spouting port 18 when a negative pressure is generated on the upstream side of the water supply line switching valve 136. As shown in Fig. 13, the rim water spouting vacuum breaker 148 is disposed above the upper edge surface of the bowl portion 12, and thereby reliably prevents back flow. In addition, flush water overflowing from the atmosphere release portion on the rim water spouting vacuum breaker 148 passes through a return pipe 150 and flows into the reservoir tank 120.

0114

20 A vacuum breaker 142 serving as a check valve is provided on the supply path 124 as well, and back flow from the reservoir tank 120 can thus be prevented.

0115

25 Here, the reservoir tank 120 is a sealed reservoir tank, and a ball-type check valve 143 is provided on the connecting portion between the supply path 124 downstream side 124a and the reservoir tank 120. Because of this ball-type check valve 143, even if the [water level in the] reservoir tank 120 exceeds the position of the top end 170a on the overflow flow path 170, described below, and is in a full state, a ball

143ax floats and the connecting portion with the supply path 124 is closed, so that back flow of flush water to the supply path 124 does not occur.

0116

5 Similarly, a ball-type check valve 144 is also provided at the connecting portion of the return pipe 150 and the reservoir tank 120, so that even if the [water level in the] reservoir tank 120 exceeds the position of the top end 170a on the overflow flow path 170, described below, and is in a full state, there is no back flow of flush water to the return pipe 150.

10

0117

In addition, a jet water spouting flapper valve 156 serving as a check valve and a drain plug 158 are provided on the pump-side supply path 145. This jet water spouting flapper valve 156 and drain plug 158 are positioned at a height in the vicinity of the bottom edge portion of the reservoir tank 120 beneath the pressurizing pump 122. Therefore by releasing the drain plug 158, flush water in the reservoir tank 120 and in the pressurizing pump 122 can be drained for maintenance and the like. By disposing the jet water spouting flapper valve 156 between the reservoir tank 120 and the pressurizing pump 122, flush water will flow in reverse from the pressurizing pump 122 to the reservoir tank 120 when the water level in the reservoir tank 120 drops below the height of the pressurizing pump 122, thereby preventing freewheeling of the pressurizing pump 122 due to an absence of flush water in the pressurizing pump 122. A water receiving tray 160 is disposed under the pressurizing pump 122 so as to receive condensed water droplets or leaks.

25

0118

A controller 162 is built into the functional portion 10 for controlling the opening/closing operation of the electromagnetic on/off valve 134, the switching

operation of the supply water path switching valve 136, and the rpm and operation time, etc. of the pressurizing pump 122.

0119

5 An upper end float switch 164a and a lower end float switch 164b are disposed inside the reservoir tank 120.

The upper end float switch 164a turns ON when the water level in the reservoir tank 120 reaches a predetermined position L2 slightly lower than the normal use maximum water level L1, this is sensed by the controller 162, which closes the
10 electromagnetic on/off valve 134.

0120

The lower end float switch 164b turns ON when the water level in the reservoir tank 120 reaches a predetermined position L3 slightly higher than the normal use
15 minimum water level L4; this is sensed by the controller 162, which stops the pressurizing pump 122.

0121

An overflow flow path 170 is further provided, and the upper end 170a of the
20 overflow flow path 170 is opened into the reservoir tank 120, whereas the lower end 170b thereof is connected to the jet-side water supply path 146.

0122

A flapper valve 172 serving as a check valve is attached to the overflow flow path
25 170. This overflow flow path 170 and flapper valve 172 prevent back flow from the jet water spouting port 16 and form a partition therebetween.

0123

The controller 162 sequentially activates the electromagnetic on/off valve 134, the pressurizing pump 122, and the supply water path switching valve 136 in response to a user turning ON a flush switch (not shown), thereby first spouting water from the rim water spouting port 18 and then, while continuing to spout water from the rim, starting the spouting of water from the jet water spouting port 16 so as to flush the bowl portion 12. Furthermore, the controller 162 continues to release the electromagnetic on/off valve 134 after flushing has ended, thereby replenishing flush water to the reservoir tank 120. When the water level inside the reservoir tank 120 rises and the top end float switch 164a detects a predetermined stored water volume, controller 162 closes the electromagnetic on/off valve 134 and stops the supply of water.

0124

Next, referring to Fig. 14, the basic operation of a fifth embodiment flush toilet will be described.

As shown in Fig. 14, the supply water path switching valve 136 in the standby state (time t_0 - t_1) is first at a rim-side fully open position (the 100% rim side/0% jet side position), communicating only with the rim-side water supply path 138. Next, when the toilet flush switch (not shown) is turned to ON (time t_1) in this standby state (time t_0 - t_1), the electromagnetic on/off valve 134 is turned to open (ON), and flush water is supplied to the reservoir tank 120, while at the same time the pressurizing pump 122 is started (turned ON) and the rpm is raised to a low speed of 1000 rpm. Simultaneously the supply water path switching valve 136 is switched from the rim-side fully open position up to the jet-side fully open position (the 0% rim side/100% jet side position).

25 0125

Next, at time t_2 - t_3 the supply water path switching valve 136 is held in the jet-side fully open position, and thereafter at time t_3 - t_4 the supply water path switching valve 136 is gradually switched from the jet-side fully open position to the rim-side fully open position, and flush water is spouted from the rim water spouting port 18.

Having once switched the supply water path switching valve 136 from the rim-side fully open position to the jet-side fully open position and thereafter to the rim fully open position, air remaining in the pump-side supply path 145 can be discharged from the jet water spouting port 16. As a result, a discharge sound in the rim water spouting port 18, arising when air in the pump-side supply path 145 is suddenly discharged from the rim side, can be prevented.

0126

Rim flushing is thus carried out during the interval (e.g. 5 seconds) from time t1 until time t5. Next, during the interval from time t5-t6, the supply water path switching valve 136 is gradually switched from the rim-side fully open position to the both sides open position, communicating with both the rim side and the jet side. After this, at time t6, the pressurizing pump 122 is rotated at high speed (e.g. 3500 rpm), and jet water spouting is commenced.

15

0127

Here, at time t6, rim water spouting is continued when jet water spouting is commenced by the pressurizing pump 122. Furthermore, rim water spouting is continued without interruption from the start until the end of jet water spouting (between time t5-t10).

20

0128

In the present embodiment, when jet water spouting commences, rim water spouting is being carried out continuously; in other words, jet water spouting is carried out in a state whereby the accumulated water level in the bowl portion 12 in the drain trap pipe 14 is rising due to rim water spouting, such that a siphon action can be induced in a short time period, and a strong siphon action can be generated. As a result, the volume of jet spouting flush water needed to start the siphon action can be reduced and water conservation can be achieved.

25

0129

In the present embodiment, rim water spouting is continued without interruption from the start until the end of jet water spouting (between time t6-t10), making it difficult
5 for air to flow into the inlet portion of the drain trap pipe, thus enabling the suppression of the siphon cutoff sound. Adhesion of the floating waste to the surface of the bowl can be prevented, and floating waste can be reliably discharged by jet spouting water while gathering floating waste at the center of the accumulated water.

10 0130

Next, the pressurizing pump 122 rpm is controlled by the controller 162 as follows during this jet water spouting.

First, at time t5-t6, prior to jet water spouting, the water supply line switching valve 136 switches from the rim-side fully open position to the both sides open position,
15 at which point the pressurizing pump 122 is held at a relatively low speed (e.g. 1000 rpm). By this means the air remaining in the vicinity of the jet-side water supply path 146 peak portion 146a (i.e. the portion located above the surface of the accumulated water in the bowl portion 12) is slowly discharged from the jet water spouting port 16. As a result, an air discharge sound from the jet water spouting port 16, which arises when the
20 pressurizing pump 122 is suddenly started up at full high-speed rotation, can be prevented.

0131

Next, at time t7-t8, the pressurizing pump 122 is run at high-speed rotation (e.g.
25 3500 rpm). This increases the pressurizing force from the pressurizing pump 122, such that a large volume of flush water is spouted from the jet water spouting port 16. At this point rim water is being continuously spouted from the rim water spouting port 18, therefore the flow volume of flush water spouted from the rim water spouting port 18 is added thereto, and a large volume of flush water flows into the drain trap pipe 14 inlet

portion 14a, such that a siphon effect is rapidly induced, and accumulated water and waste are quickly discharged from the bowl portion 12. At this point the flow volume (first flow volume) flowing into the drain trap pipe 14 inlet portion 14a is a large flow volume compared to the past, at a total of 75 liters/minute-120 liters/minute as the flow volumes
5 from rim water spouting and jet water spouting.

0132

Next, at time t8-t9, the volume of flush water (the second flow volume) flowing into the drain trap pipe 14 inlet portion 14a is less than the flow volume described above
10 (the first flow volume), therefore the rpm of the pressurizing pump 112 is made slightly lower. In the Fig. 14 example, the rpm of the pressurizing pump 122 is made to decrease to a second stage (e.g. 3300 rpm and 3200 rpm). At this point the rpm of the pressurizing pump 122 may also be a single stage without variation, or may be reduced in three or more stages.

15

0133

Thus in the present embodiment a second flow volume of flush water, less than a first flow volume, is caused to flow into the drain trap pipe 14 inlet portion 14a immediately before the end of the siphon effect generated by the first flow volume (time
20 t8).

0134

In the fifth embodiment as well, the second embodiment flow volume is the flow volume needed to generate at least a flow speed such that waste in the bowl portion 12
25 can pass over the drain trap pipe 14 peak portion 14d and be conveyed. As in the above described third embodiment, the flow volume can be adjusted within a range in which waste can be conveyed from the bowl portion 12. By making this second flow volume less than the first low-volume, discharge of waste floating in the bowl portion 12 with a lower flow volume allows for greater water conservation, as well as a quieter operation

due to the reduced sound of water spouting from the jet water spouting port 16. Moreover, the inertial force of the pressurizing pump 122 is reduced by lowering the rpm of the pressurizing pump 122; reducing the pressurizing pump 122 inertial force means that a smaller amount of flush water is sufficient to be drawn in from the reservoir tank
5 120, so that even though the size of the reservoir tank 120 is made smaller, sucking in of air by the pressurizing pump 34 in what is known as "air cavitation" can be prevented.

0135

In the fifth embodiment, as in the above-described third embodiment, a similar
10 first pattern, second pattern, and/or third pattern can be executed by adjusting the second flow volume to various values.

0136

Next, at time t10, at which point a predetermined time interval (e.g. 5 seconds)
15 has elapsed from time t5, the pressurizing pump 122 is set to rotate at low speed (e.g. 1000 rpm). At the same time, a water supply path switching valve 136 is switched from the both sides open position to the rim-side fully open position. The rpm of the pressurizing pump 122 is slowly reduced during the period from time t10 to time t11 so as to gradually reduce the spouting of water from the jet water spouting port 16. The
20 siphon cutoff sound generated by a sudden interruption in siphon action can thus be prevented (particularly in the first pattern).

0137

At time t11, jet water spouting has ended, but rim water spouting continues as
25 before.

Next, at time t12, when the flush water level in the reservoir tank 120 falls to water level L3 and the bottom end float switch 164b turns ON, the pressurizing pump 122 stops operating. After this time t12, the pressurizing pump 122 is in a stopped state, but the electromagnetic on/off valve 134 is still in an open state, therefore subsequent to

time t12 the reservoir tank 120 is being replenished with flush water (the tank is being supplied with water).

0138

5 Next, the top end float switch 164a turns ON as a result of the rise of the water level in the reservoir tank 120 and thereafter, at time t15, the electromagnetic on/off valve 134 is OFF and flush water is stopped from flowing into the reservoir tank 120.

0139

10 At this time t15, the water supply line switching valve 136 is in a rim-side fully open position, and [the system] is restored to the standby state (the same state as at time t0).

0000

15 Although the present invention has been explained with reference to a specific, preferred embodiment, one of ordinary skill in the art will recognize that modifications and improvements can be made while remaining within the scope and spirit of the present invention. The scope of the present invention is determined solely by the appended claims.

20

What is claimed is:

1. A flush toilet cleaned by pressurized flush water, said flush toilet comprising:
 - a toilet main unit provided with a bowl portion, a rim water spouting port and jet water spouting port both for expelling flush water, and a drain trap pipe;
 - a reservoir tank for storing flush water;
 - rim spout water supply means for supplying flush water to the rim water spouting port at a predetermined timing;
 - reservoir water supply means for supplying flush water to the reservoir tank at a predetermined timing;
 - a pressurizing pump for pressurizing flush water stored in the reservoir tank and supplying the flush water to the jet water spouting port; and
 - pressurizing pump control means for controlling the operation of the pressurizing pump and the rpm thereof so as to control the flow speed and the flow volume of flush water spouted from the jet water spouting port;
 - wherein the drain trap pipe includes an inlet portion, a trap ascending pipe rising from the inlet portion, and a trap descending pipe dropping from the trap ascending pipe;
 - the jet water spouting port is disposed approximately horizontally, pointing toward the inlet portion of the drain trap pipe; and
 - the pressurizing pump control means controls the rpm of the pressurizing pump so that a first flow volume for generating a siphon action is spouted from the jet water spouting port, then a second flow volume is spouted, generating a flow speed capable of conveying waste, and in such a way as to seal a cross section at some location of the drain trap pipe, thereby continuing the siphon action, prior to the end of the siphon action generated by the first flow volume.

2. The flush toilet according to claim 1, wherein the pressurizing pump control means controls the rpm of the pressurizing pump such that the second flow volume is smaller than the first flow volume.

3. The flush toilet according to claim 1 or 2, wherein the pressurizing pump control means controls the rpm of the pressurizing pump in such a way that water spouted from the jet water spouting port gradually decreases when spouting of the second flow volume ends.
4. The flush toilet according to any one of claims 1-3, wherein the first flow volume is between 75-120 liters/minute.
5. The flush toilet according to any one of claims 1-4, wherein the flow speed of flush water spouted from the jet water spouting port by the pressurizing pump controlled by the pressurizing pump control means is between 3.0-6.2 meters/second.
6. A flush toilet cleaned by pressurized flush water, said flush toilet comprising:
a toilet main unit provided with a bowl portion, a rim water spouting port and jet water spouting port for expelling flush water, and a drain trap pipe;
a reservoir tank for storing flush water;
rim spout water supply means for supplying flush water to the rim water spouting port at a predetermined timing;
reservoir water supply means for supplying flush water to the reservoir tank at a predetermined timing;
pressurizing means for pressurizing flush water stored in the reservoir tank and supplying the flush water to the jet water spouting port; and
pressurizing means control means for controlling the operation of the pressurizing means and controlling the volume pressurized by the pressurizing means so as to control the flow speed and flow volume of flush water spouted from the jet water spouting port;

wherein the drain trap pipe includes an inlet portion, a trap ascending pipe rising from the inlet portion, and a trap descending pipe dropping from the trap ascending pipe;

the jet water spouting port is disposed approximately horizontally, pointing toward
5 the inlet portion of the drain trap pipe; and

the pressurizing means control means controls the volume pressurized by the pressurizing means so that a first flow volume for generating a siphon action is spouted from the jet water spouting port, and a second flow volume, smaller than the first flow volume and generating a flow speed capable at least of conveying waste, is spouted
10 prior to the end of the siphon action generated by the first flow volume.

7. The flush toilet according to claim 6, wherein the pressurizing means control means controls the volume pressurized by the pressurizing means so that, prior to the end of the siphon action, a second flow volume is spouted, generating a flow speed
15 capable of conveying waste, and in such a way as to seal a cross section at some location of the drain trap pipe, essentially filling the drain trap pipe and thereby continuing the siphon action.

8. The flush toilet according to claim 6, wherein the pressurizing means control
20 means controls the volume pressurized by the pressurizing means so that before the siphon action ends, a second flow volume is spouted, generating a flow speed capable of conveying waste, and in such a way as to seal a cross section at some location of the drain trap pipe.

25 9. The flush toilet according to claim 6 wherein the pressurizing means control means controls the volume pressurized by the pressurizing means so that before the siphon action ends, a second flow volume is spouted, generating a flow speed capable of conveying waste, without sealing a cross section at some location of the drain trap pipe.

10. The flush toilet according to any one of claims 6-9, wherein the pressurizing means control means controls the volume pressurized by the pressurizing means so that water spouted from the jet water spouting port gradually decreases when spouting of the second flow volume from the jet water spouting port ends.
11. The flush toilet according to any one of claims 6-10, wherein the first flow volume is between 75-120 liters/minute.
12. The flush toilet according to claims 6-10, wherein the flow speed of flush water spouted from the jet water spouting port by the pressurizing means under the control of the pressurizing means control means is between 3.0-6.2 meters/second.
13. A flush toilet cleaned by pressurized flush water, said flush toilet comprising:
a toilet main unit provided with a bowl portion, a rim water spouting port and jet water spouting port for expelling flush water, and a drain trap pipe;
a reservoir tank for storing flush water;
rim spout water supply means for supplying flush water to the rim water spouting port at a predetermined timing;
a pressurizing pump for pressurizing flush water stored in the reservoir tank;
jet spout water supply means for supplying flush water pressurized by the pressurizing pump to the jet water spouting port at a predetermined timing; and
control means for controlling the rim spout water supply means, the pressurizing pump, and the jet spout water supply means to spout flush water to the bowl portion of the toilet main unit;
wherein the control means controls the rim spout water supply means, the pressurizing pump, and the jet spout water supply means so that flush water is first spouted from the rim water spouting port and then, as spouting of flush water from the

rim water spouting port is continued, a first flow volume generating a siphon action is spouted from the jet water spouting port.

14. The flush toilet according to claim 13, wherein the jet water spouting port is disposed approximately horizontally, pointing toward the inlet portion of the drain trap pipe.

15. The flush toilet according to claim 13 or 14, wherein the control means controls the rim spout water supply means, the pressurizing pump, and the jet spout water supply means in such a way that after the first flow volume generating a siphon action is spouted from the jet water spouting port, prior to the end of the siphon action generated by the first flow volume, a second flow volume is spouted which is smaller than the first flow volume and generates at least a flow speed capable of conveying waste.

16. The flush toilet according to any one of claims 13-15, wherein the rim spout water supply means spouts flush water from the rim water spouting port under water main supply pressure.

17. The flush toilet according to any one of claims 13-16, wherein the control means causes the pressurizing pump to rotate at a predetermined low speed so as to discharge remaining air within the water supply path connecting the pressurizing pump and the jet water spouting port, prior to spouting the first flow volume of flush water from the jet water spouting port.

18. The flush toilet according to any one of claims 13-17, wherein the control means controls the rim spout water supply means so that when water is spouted from the jet water spouting port, water continues to be spouted from the rim water spouting port.

19. The flush toilet according to claim 15, wherein the control means controls the rim spout water supply means, pressurizing pump, and the jet spout water supply means so that the total of the flow volume spouted from the rim water spouting port and the first flow volume spouted from the rim water spouting port is between 75-120 liters/minute.

5

20. The flush toilet according to any one of claims 13-19, wherein the flow speed of flush water spouted from the jet water spouting port by the pressurizing pump is between 3.0-6.2 meters/second.

- 10 21. A flush toilet cleaned by pressurized flush water, said flush toilet comprising:
 a toilet main unit provided with a bowl portion, a rim water spouting port and jet water spouting port for expelling flush water, and a drain trap pipe;
 a reservoir tank for storing flush water;
 a pressurizing pump for pressurizing flush water stored in the reservoir tank;
 15 rim spout water supply means for supplying flush water pressurized by the pressurizing pump to the rim water spouting port at a predetermined timing;
 jet spout water supply means for supplying flush water pressurized by the pressurizing pump to the jet water spouting port at a predetermined timing; and
 control means for controlling the rim spout water supply means, the pressurizing
 20 pump, and the jet spout water supply means to spout flush water to the bowl portion of the toilet main unit;
 wherein the control means controls the rim spout water supply means, the pressurizing pump, and the jet spout water supply means so that flush water is first spouted from the rim water spouting port and then, as spouting of flush water from the
 25 rim water spouting port is continued, a first flow volume generating a siphon action is spouted from the jet water spouting port.

1/13
FIG.1

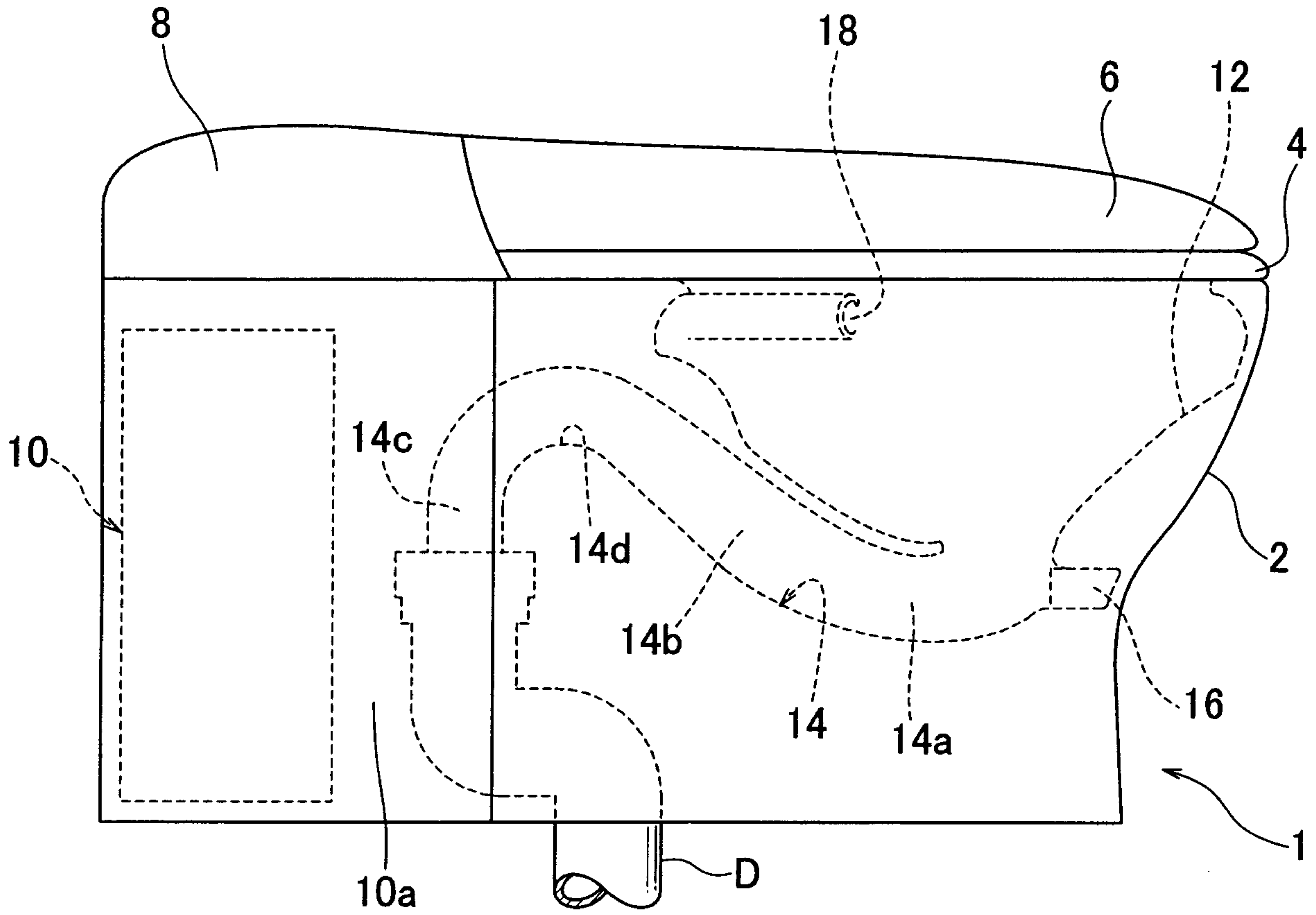

FIG.2

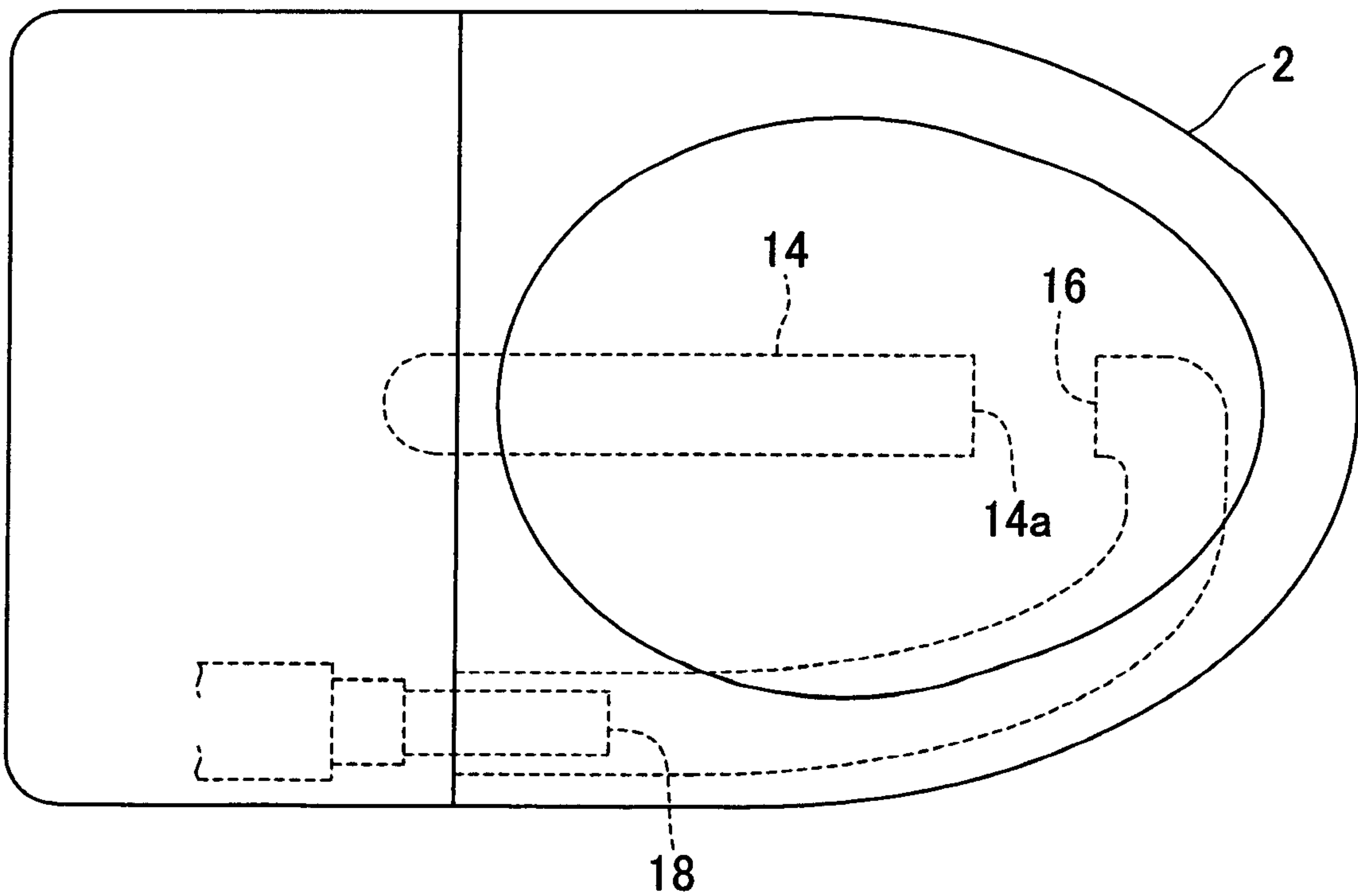
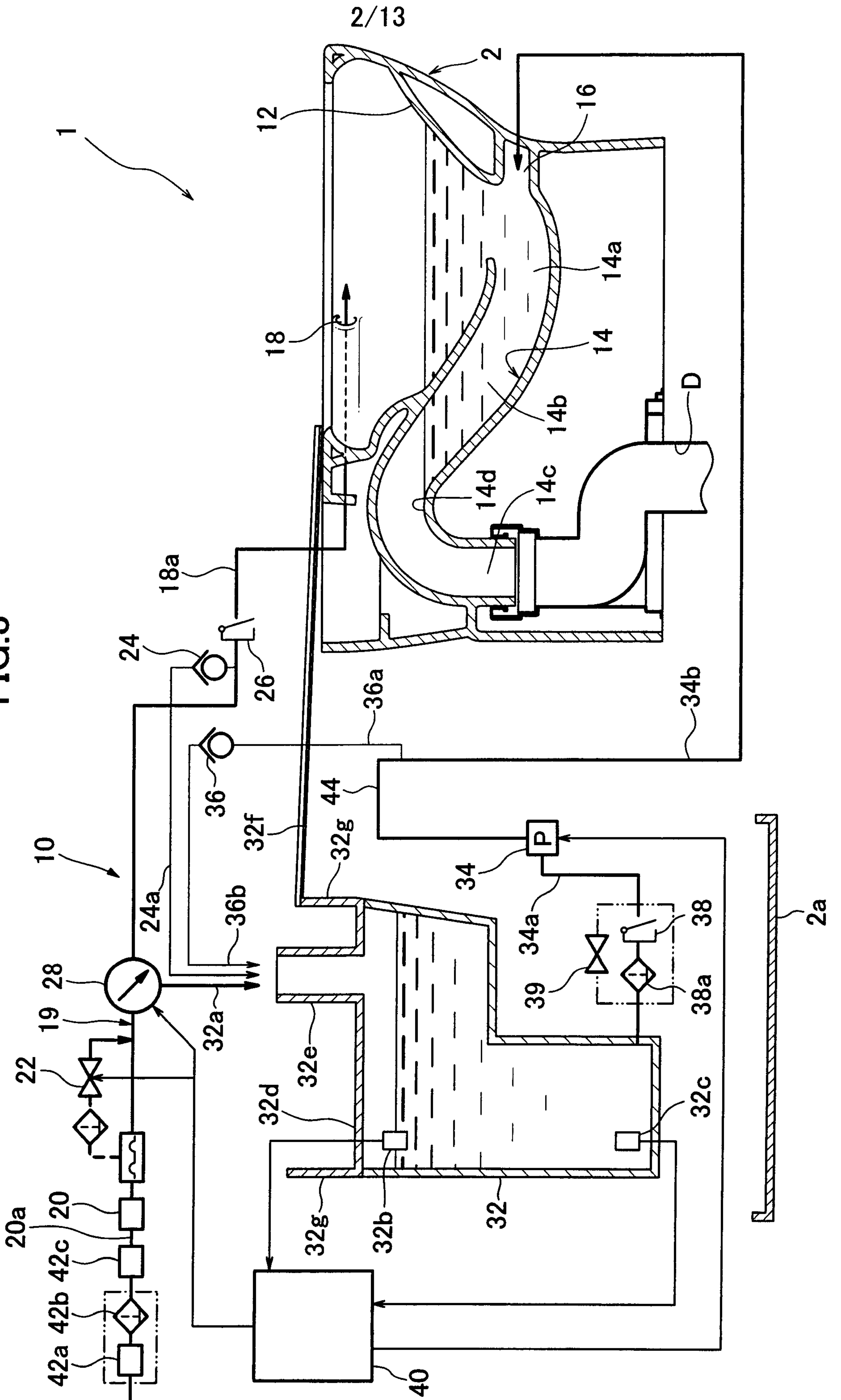
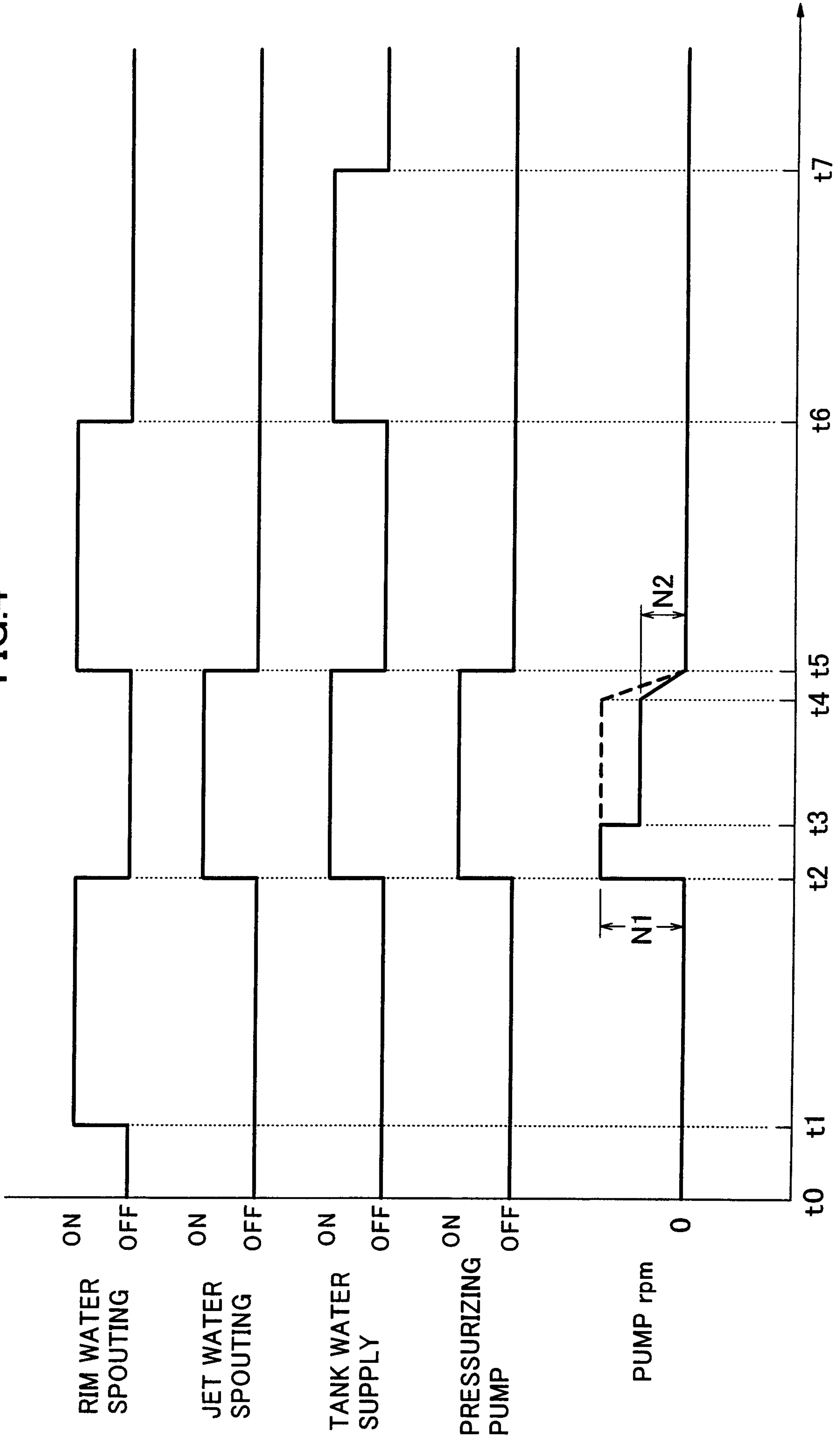

FIG.3



2/13

FIG.4



4/13
FIG.5

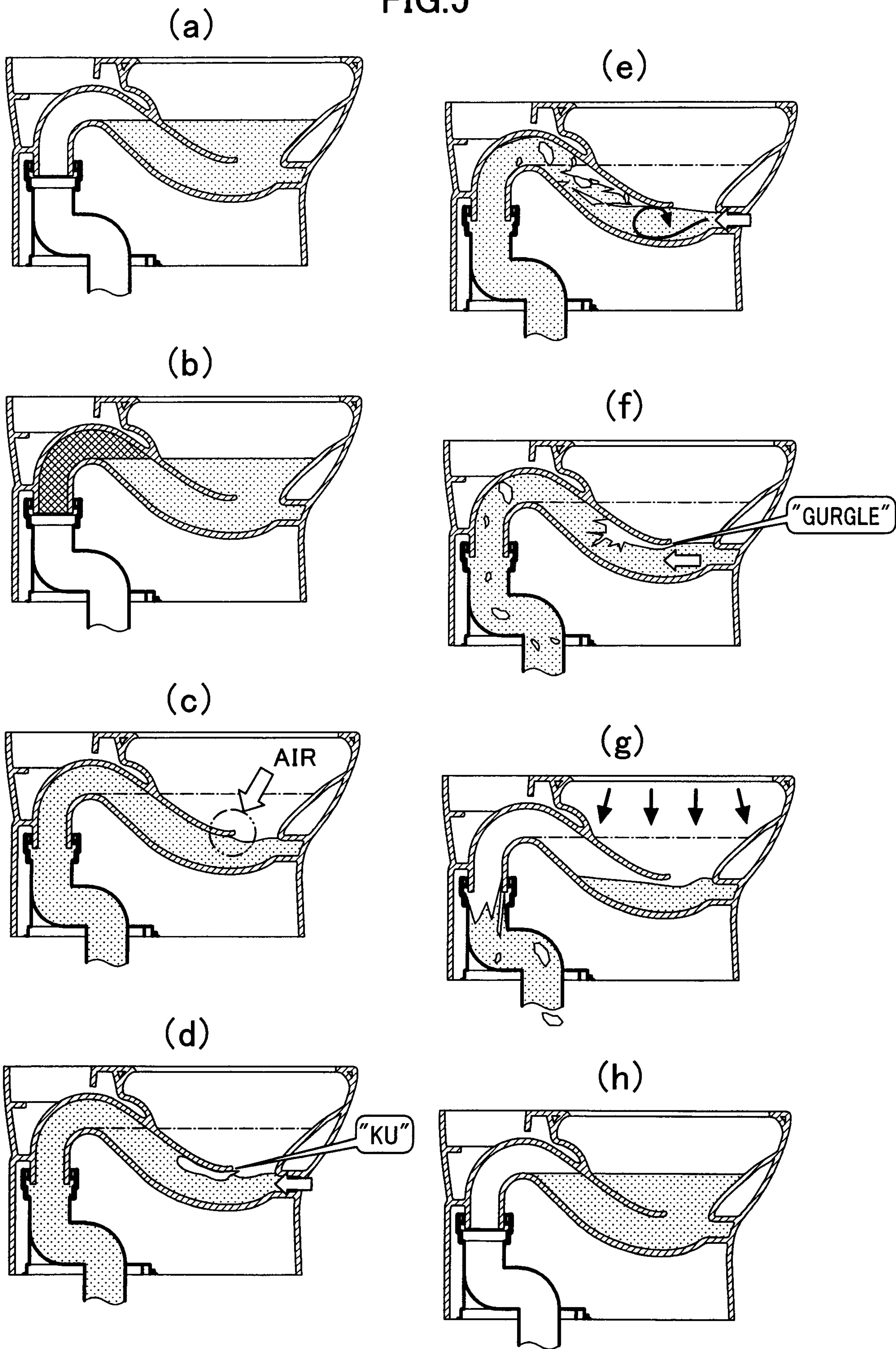

FIG.6

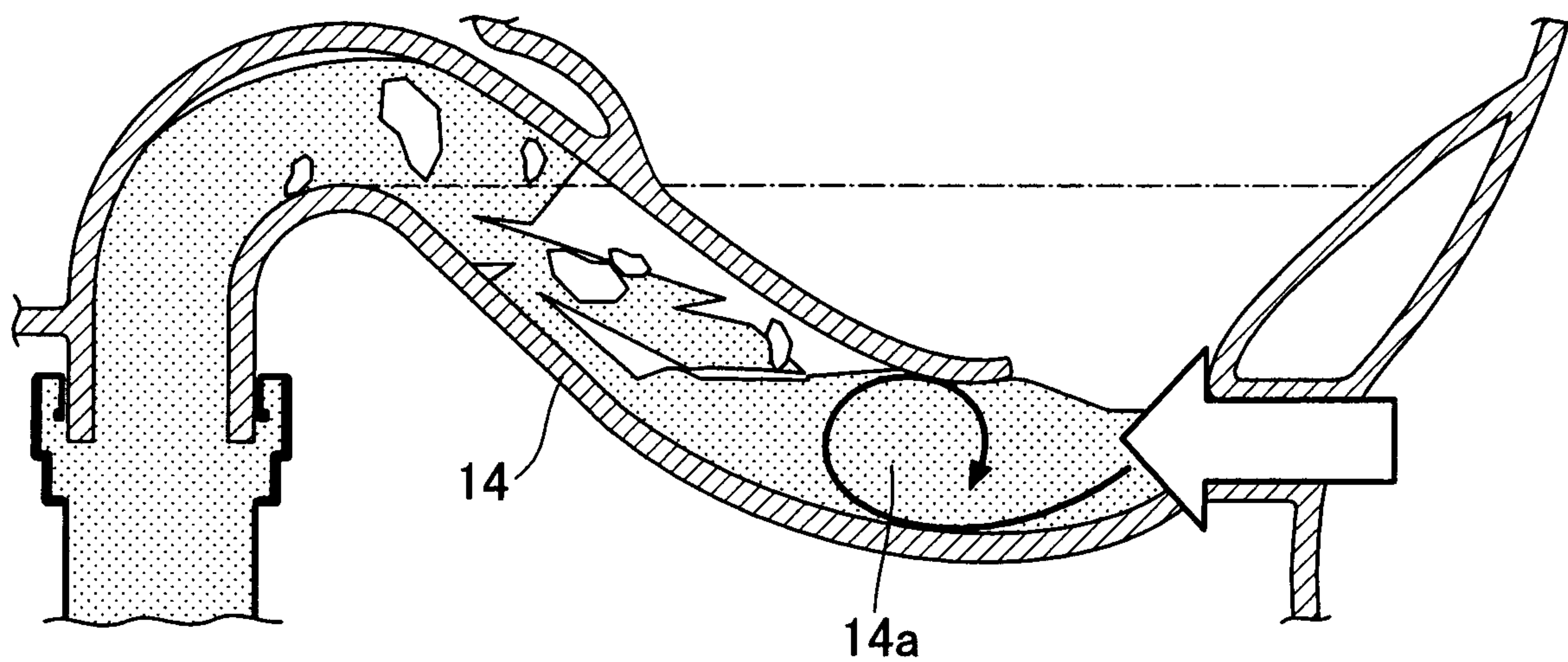
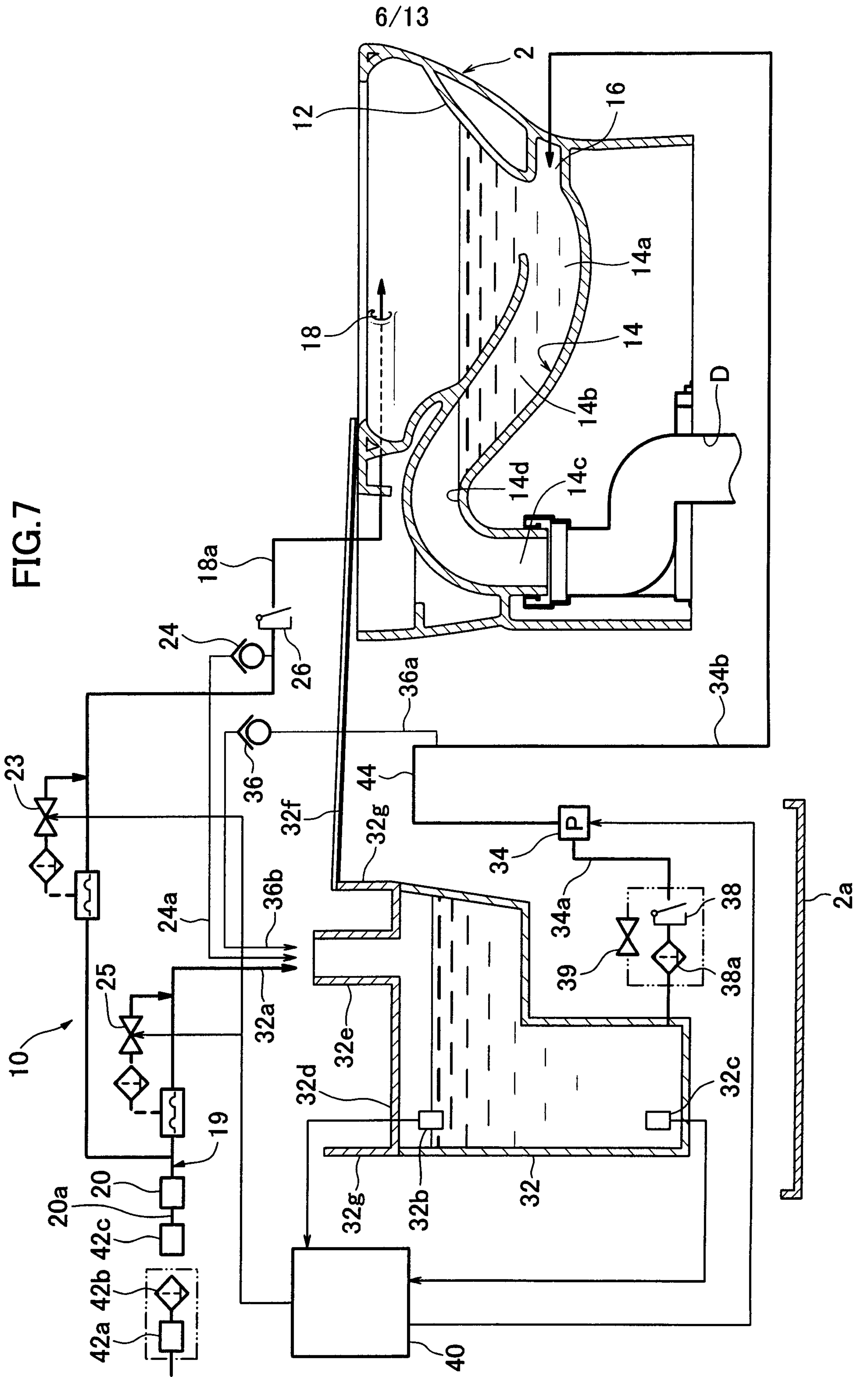

FIG. 7



7/13

FIG.8

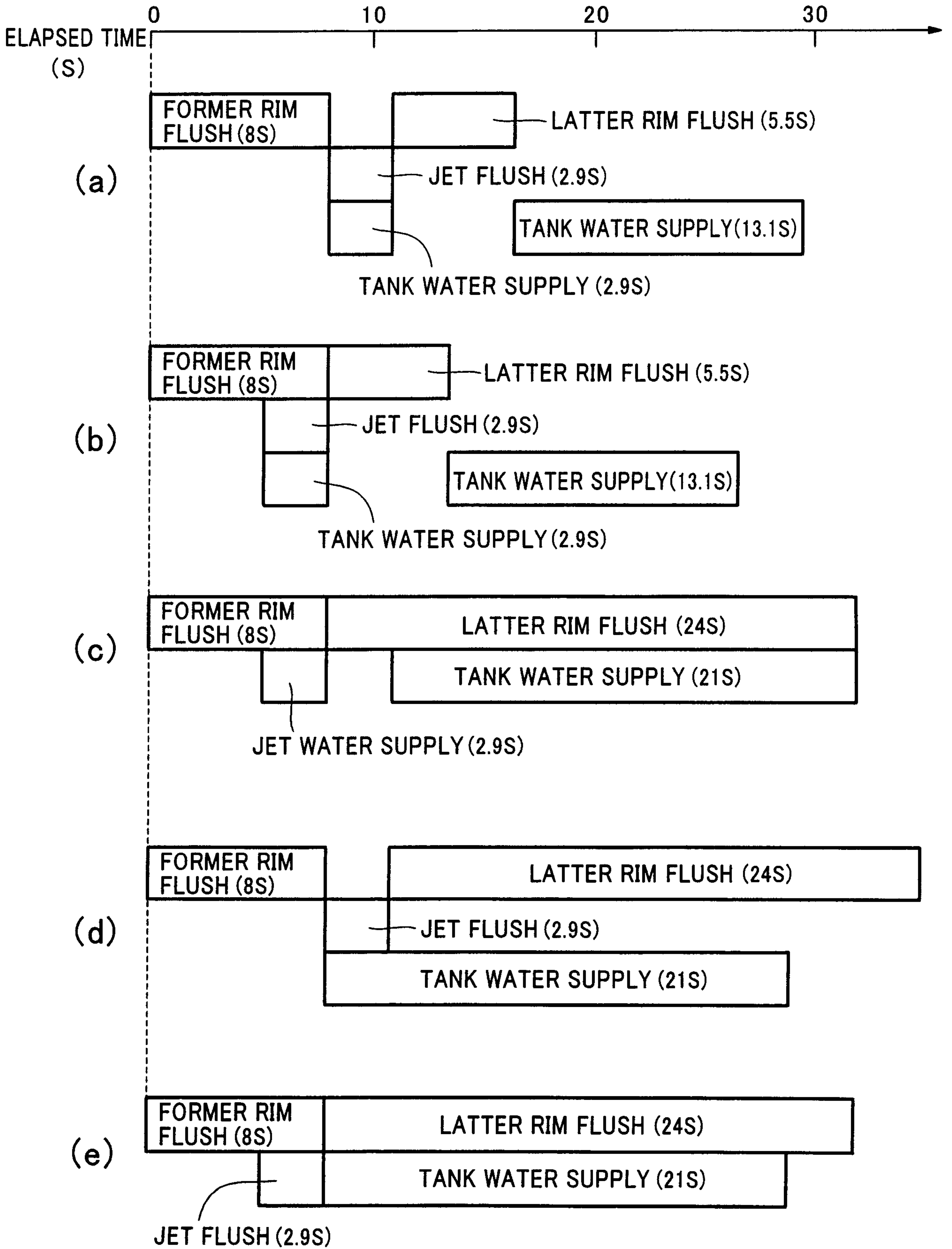
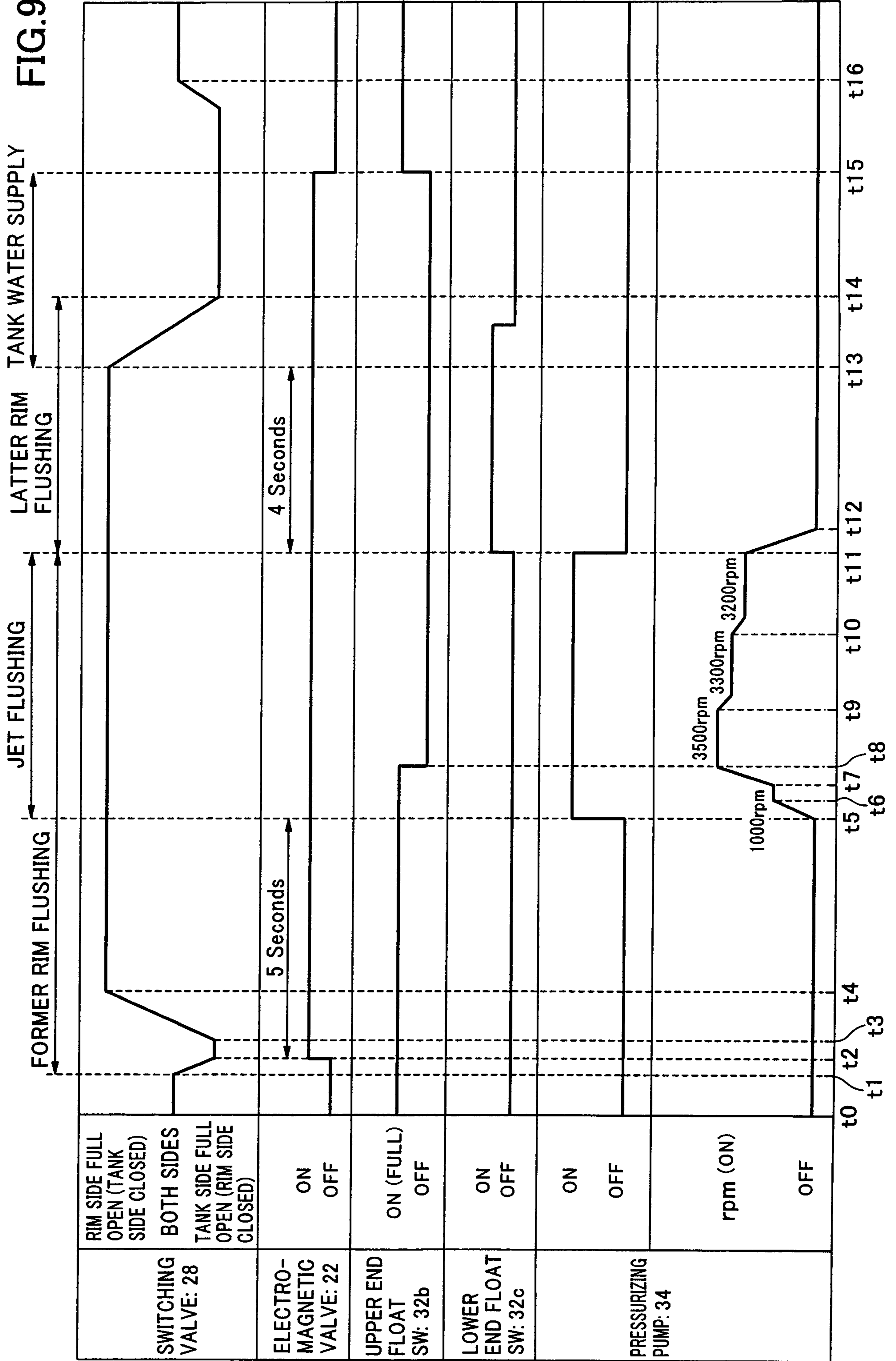
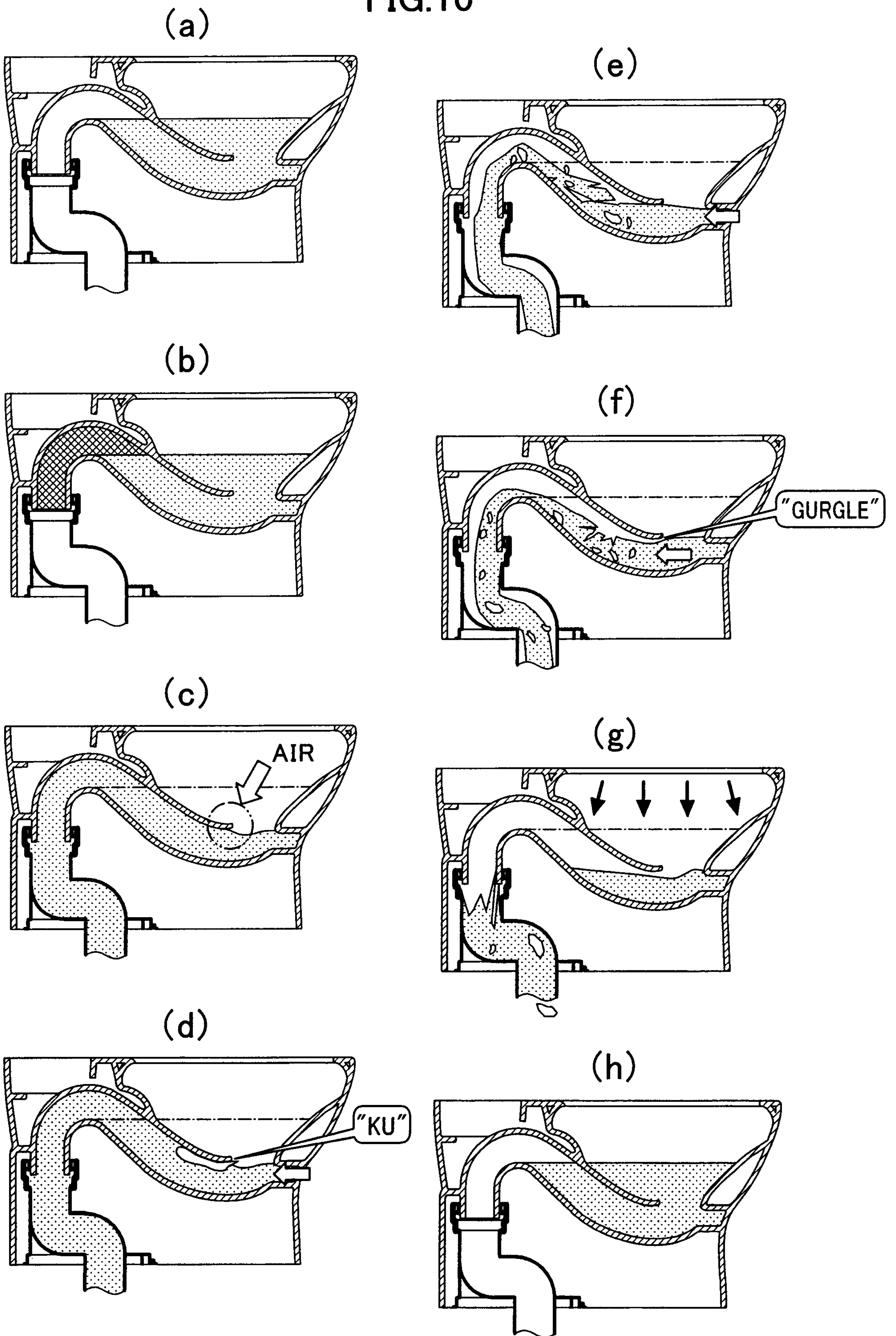

FIG.9



9/13
FIG.10



10/13
FIG.11

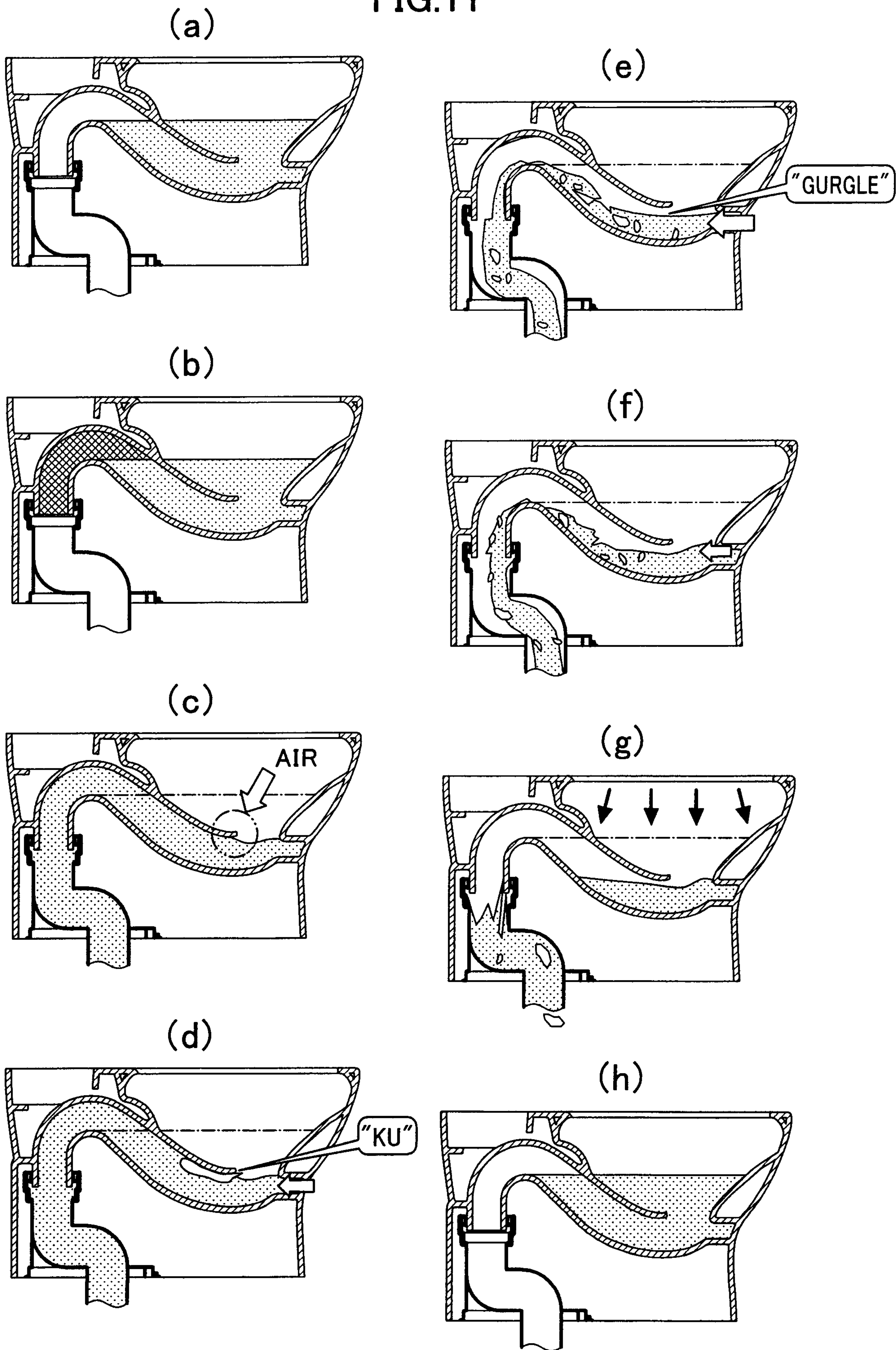

FIG.12

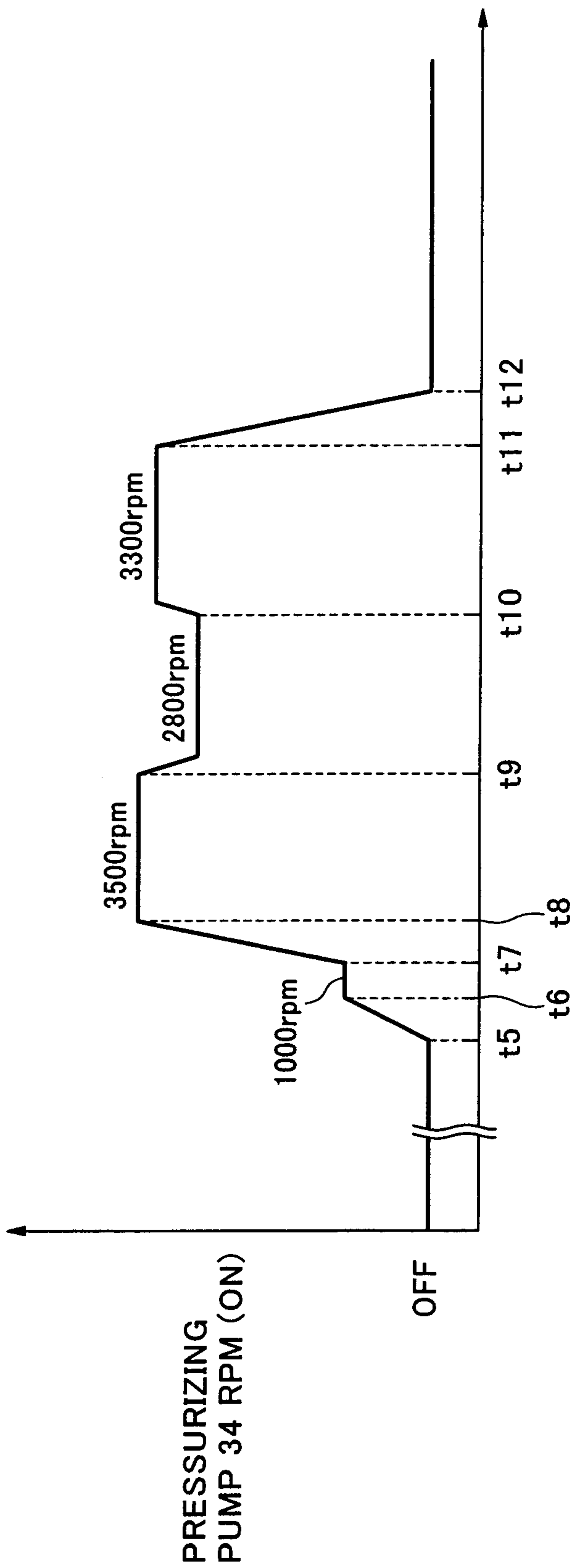

FIG.13

