



(19) **United States**

(12) **Patent Application Publication**  
**MORI et al.**

(10) **Pub. No.: US 2022/0034524 A1**

(43) **Pub. Date: Feb. 3, 2022**

(54) **OUTDOOR UNIT OF AIR-CONDITIONING APPARATUS**

*F24F 11/00* (2006.01)

*F24F 11/79* (2006.01)

(71) Applicant: **Mitsubishi Electric Corporation**,  
Tokyo (JP)

(52) **U.S. Cl.**  
CPC ..... *F24F 1/24* (2013.01); *F24F 1/46*  
(2013.01); *F24F 2110/10* (2018.01); *F24F 11/79* (2018.01); *F24F 11/0001* (2013.01)

(72) Inventors: **Tomohiro MORI**, Tokyo (JP); **Keizo KAMADA**, Tokyo (JP)

(57) **ABSTRACT**

(21) Appl. No.: **17/279,896**

An outdoor unit of an air-conditioning apparatus includes a compressor, a heat exchanger, and a controller. The controller includes a compressor driving circuit configured to drive the compressor, a harmonic suppressing unit configured to suppress harmonics in the compressor driving circuit, and a housing containing the compressor driving circuit and the harmonic suppressing unit. The housing has a first section having ventilation holes that allow communication between the outside and the inside, and a second section constituting a frame outside the first section. The first section contains the harmonic suppressing unit and a fan configured to blow air from inside the first section to the outside through the ventilation holes. The second section contains the compressor driving circuit.

(22) PCT Filed: **Nov. 16, 2018**

(86) PCT No.: **PCT/JP2018/042416**

§ 371 (c)(1),

(2) Date: **Mar. 25, 2021**

**Publication Classification**

(51) **Int. Cl.**  
*F24F 1/24* (2006.01)  
*F24F 1/46* (2006.01)

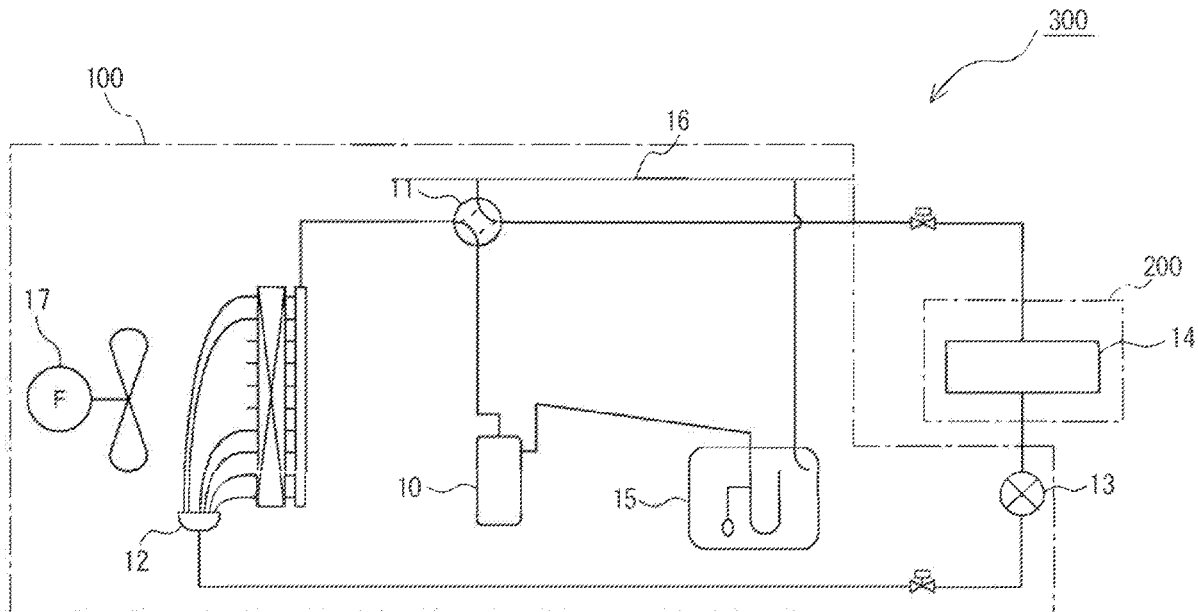

FIG. 1

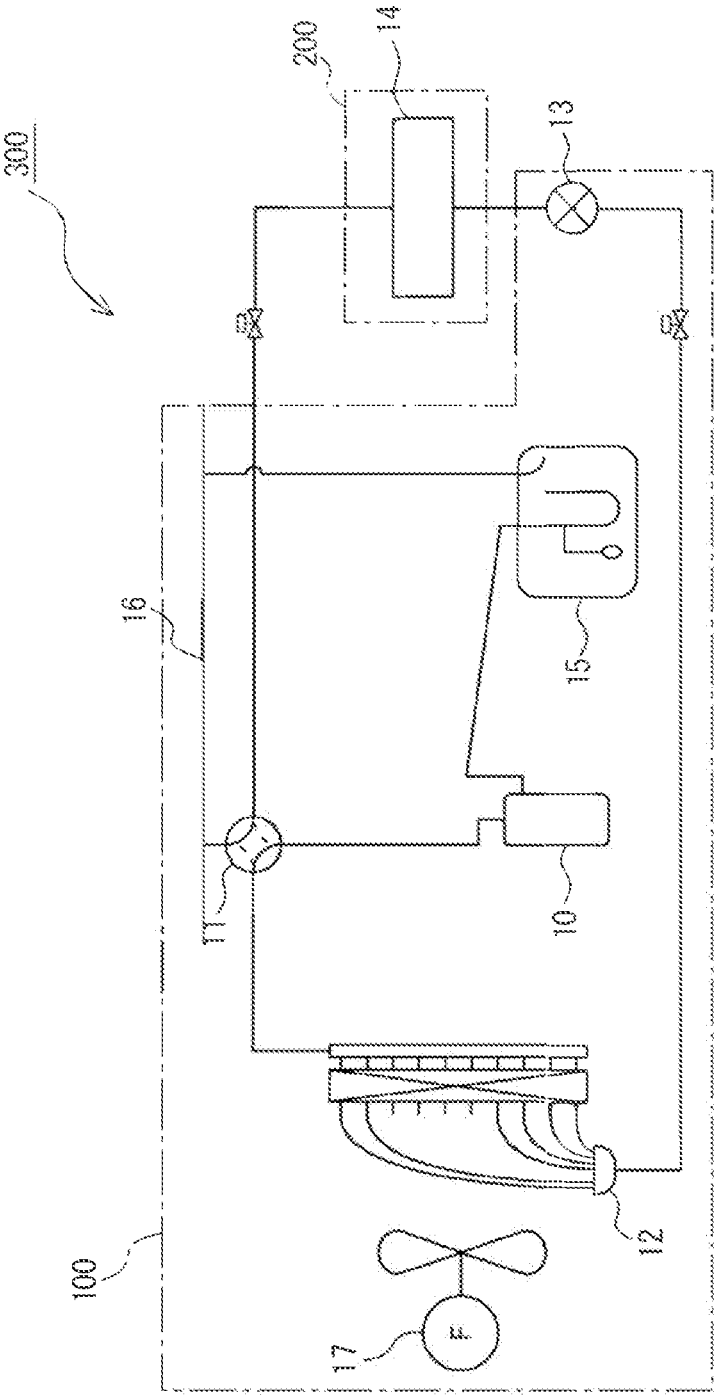

FIG. 2

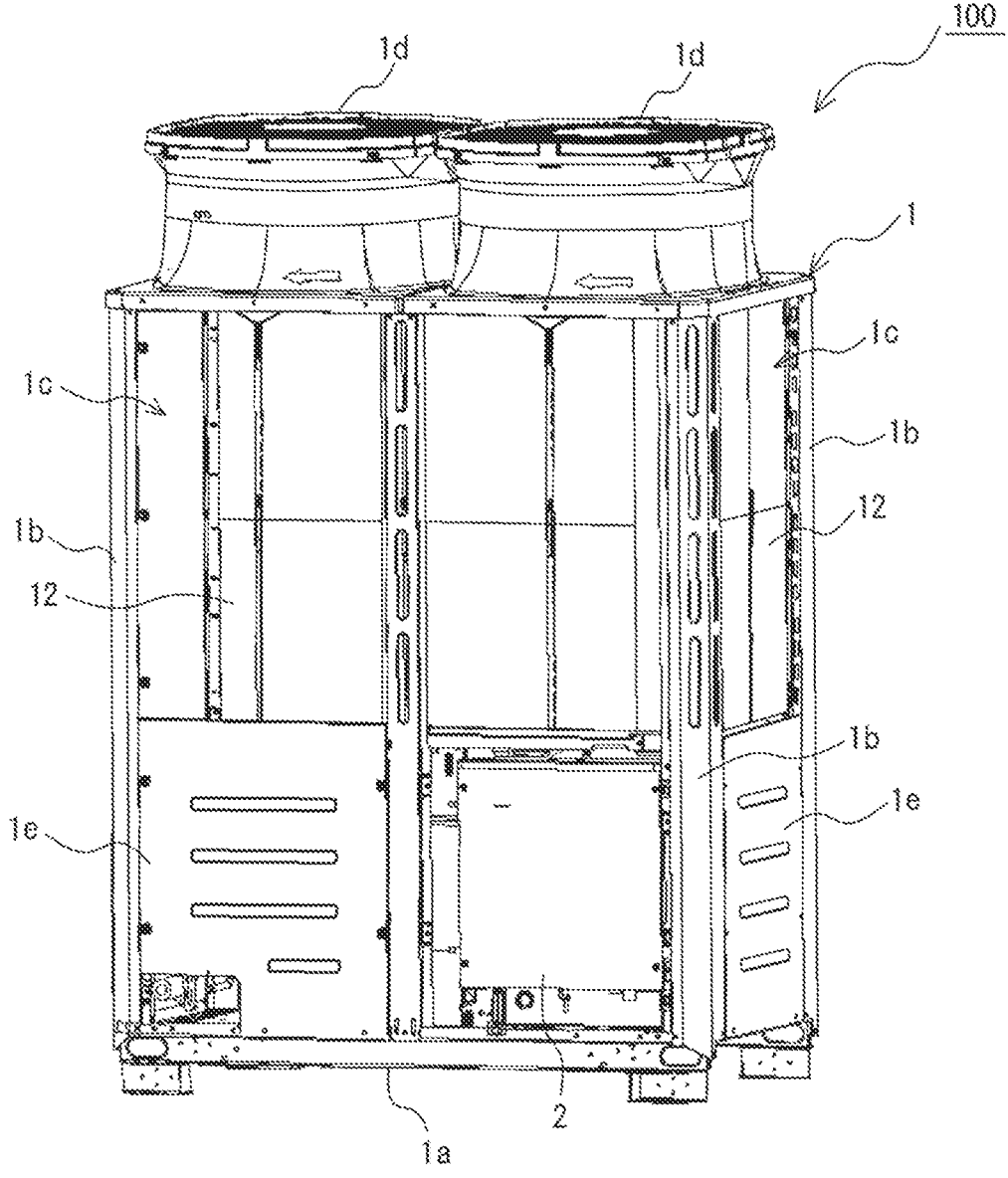

FIG. 3

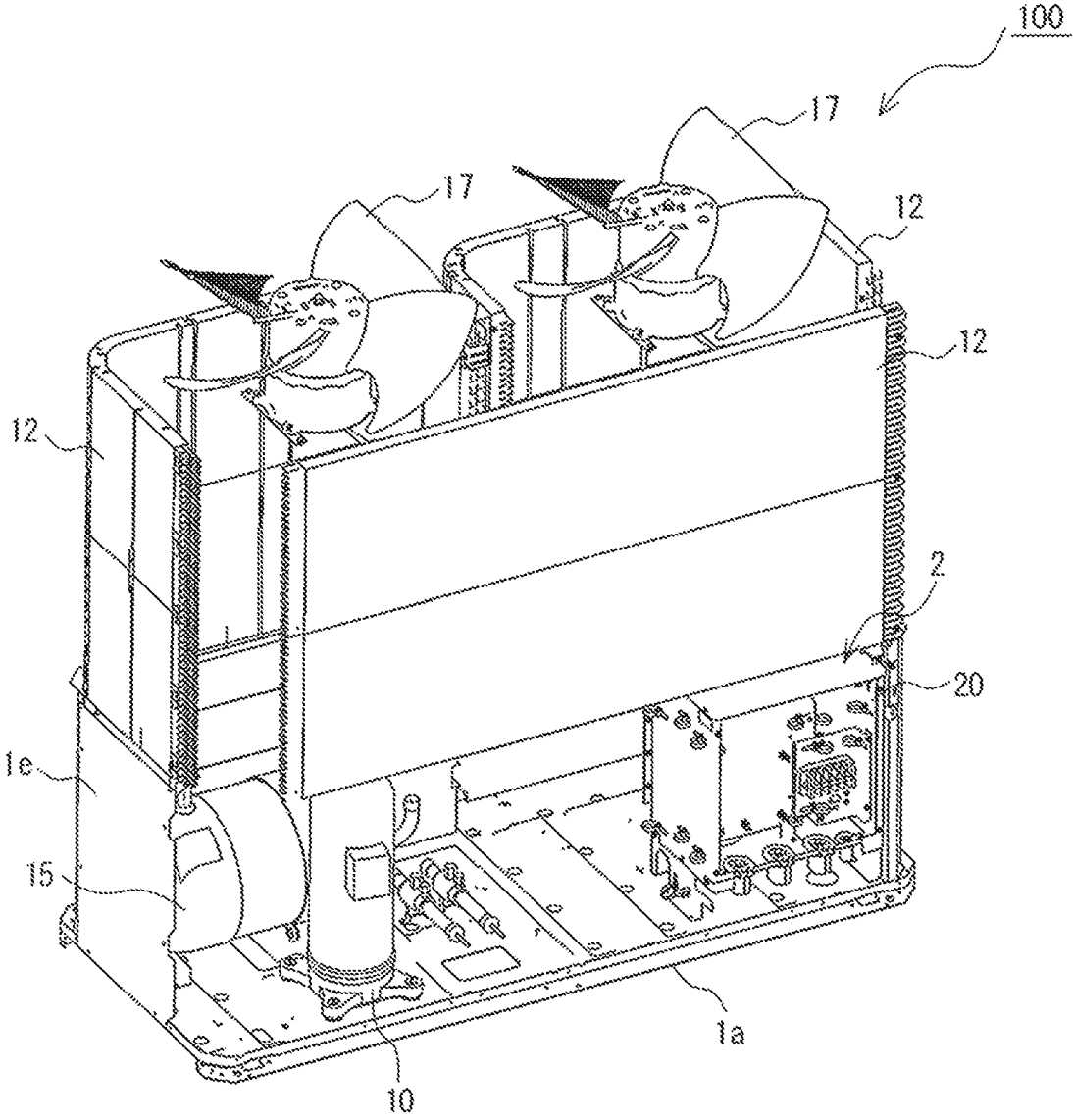

FIG. 4

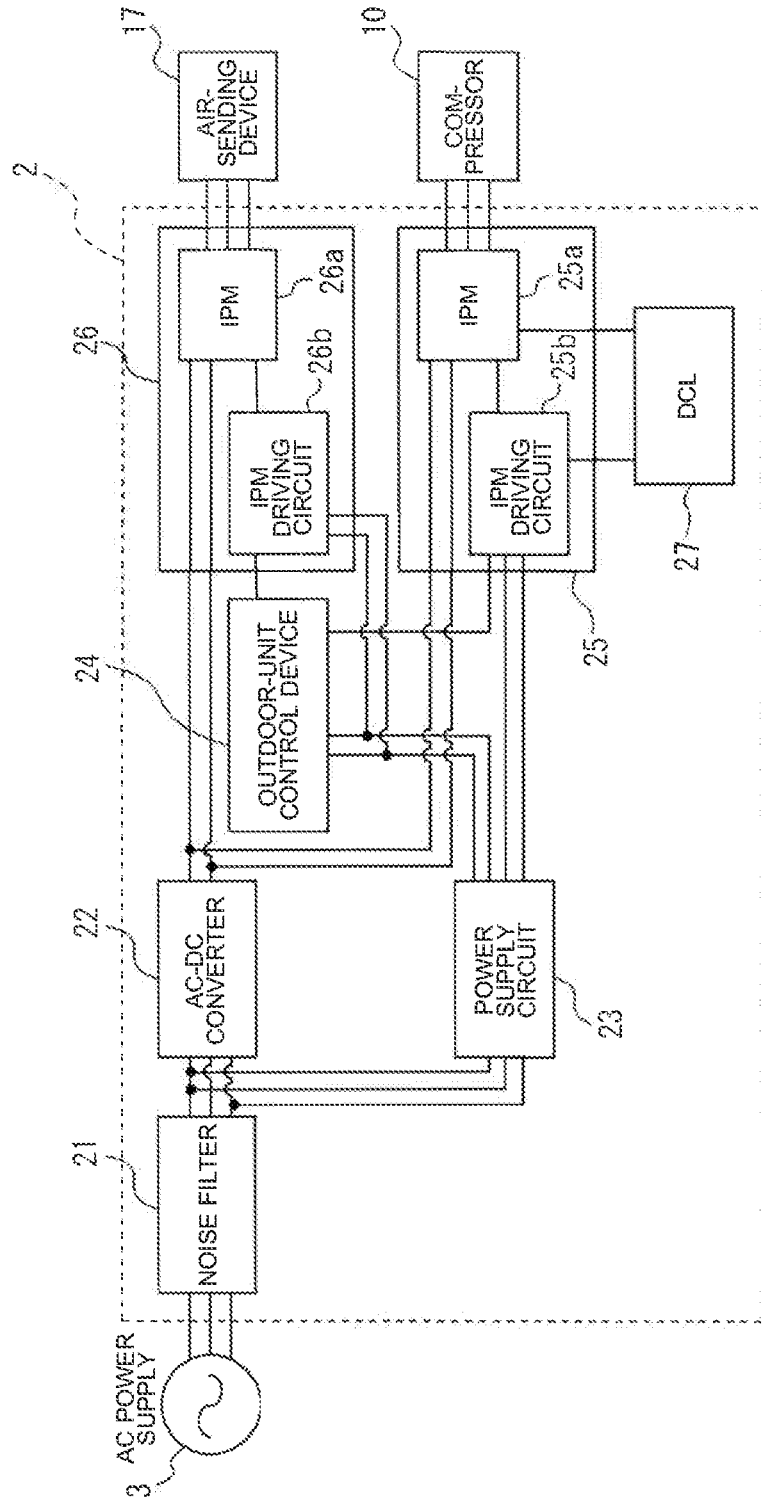

FIG. 5

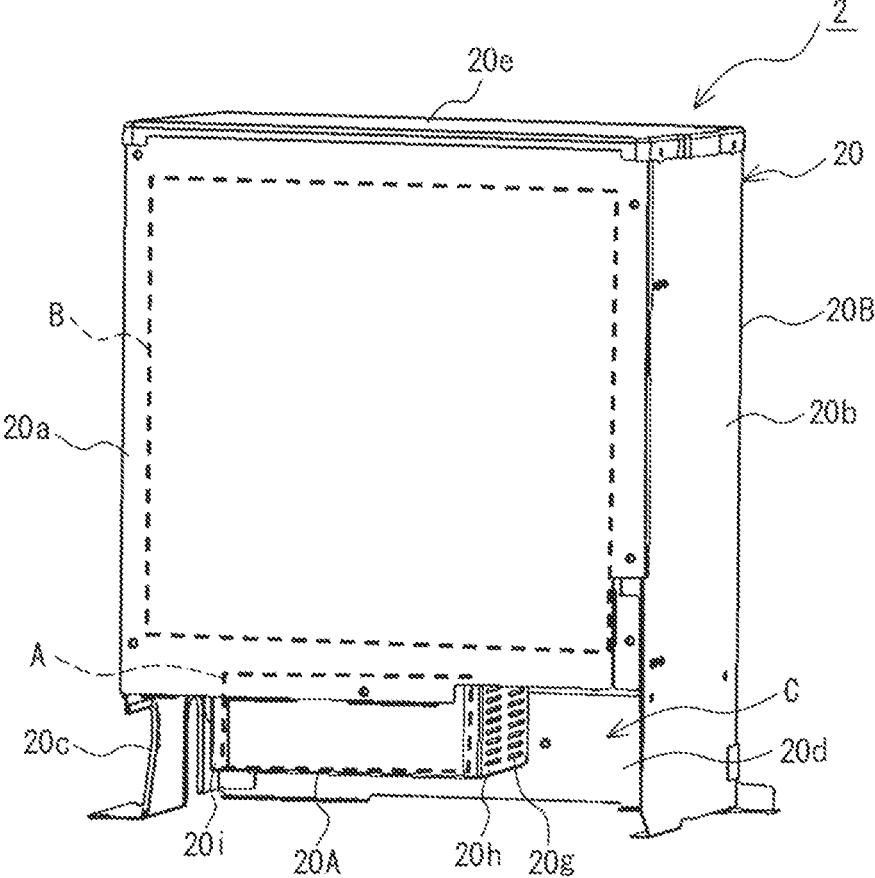

FIG. 6

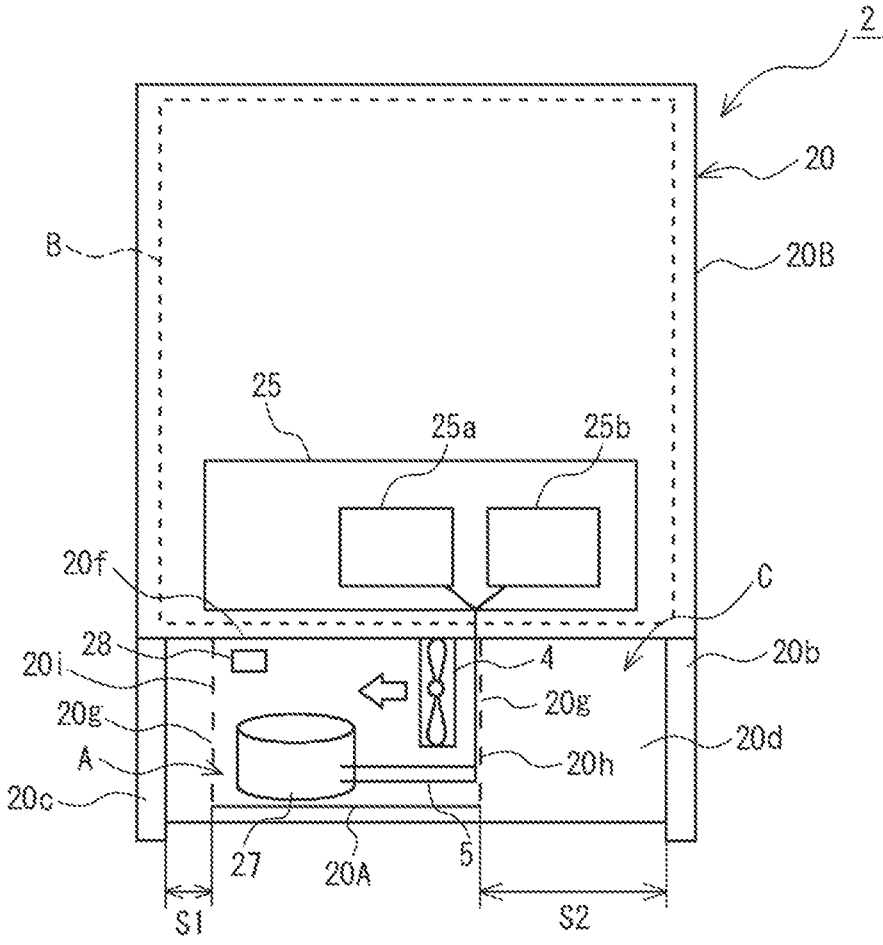

FIG. 7

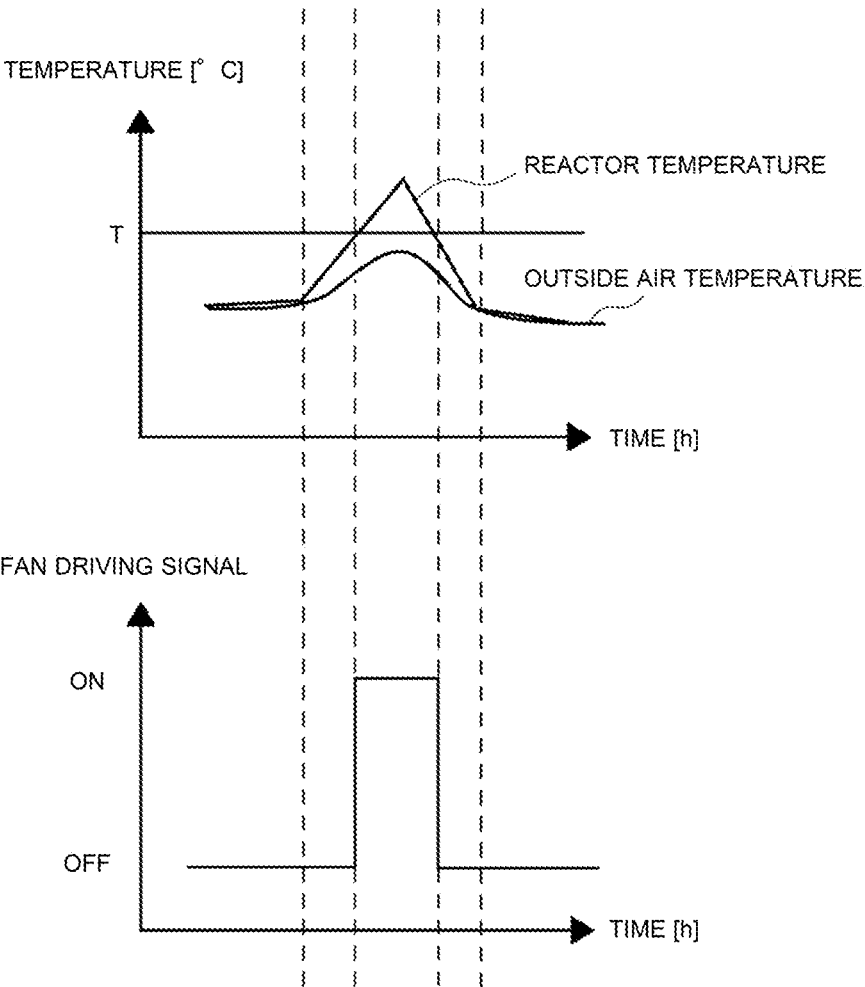



FIG. 8

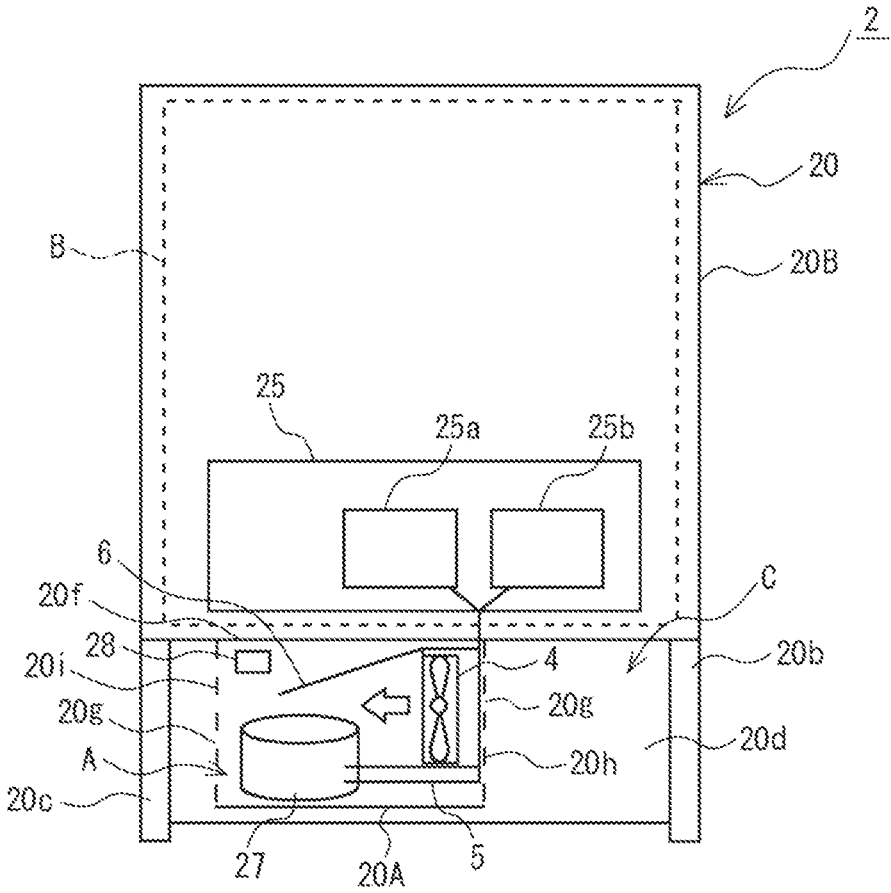

FIG. 9

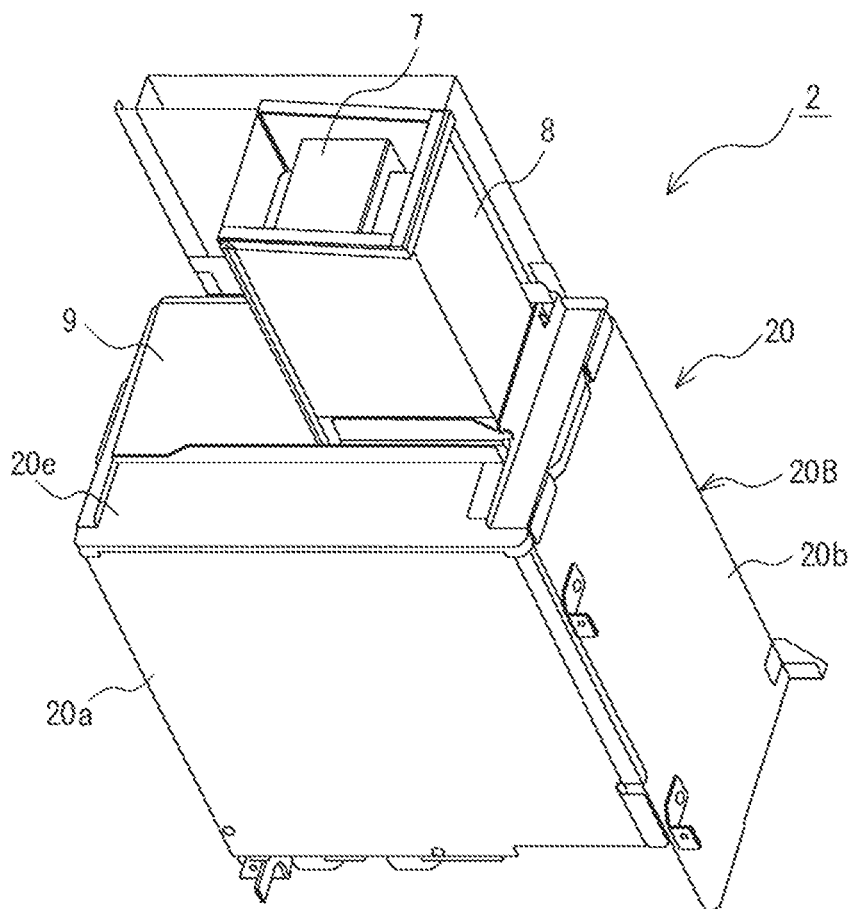
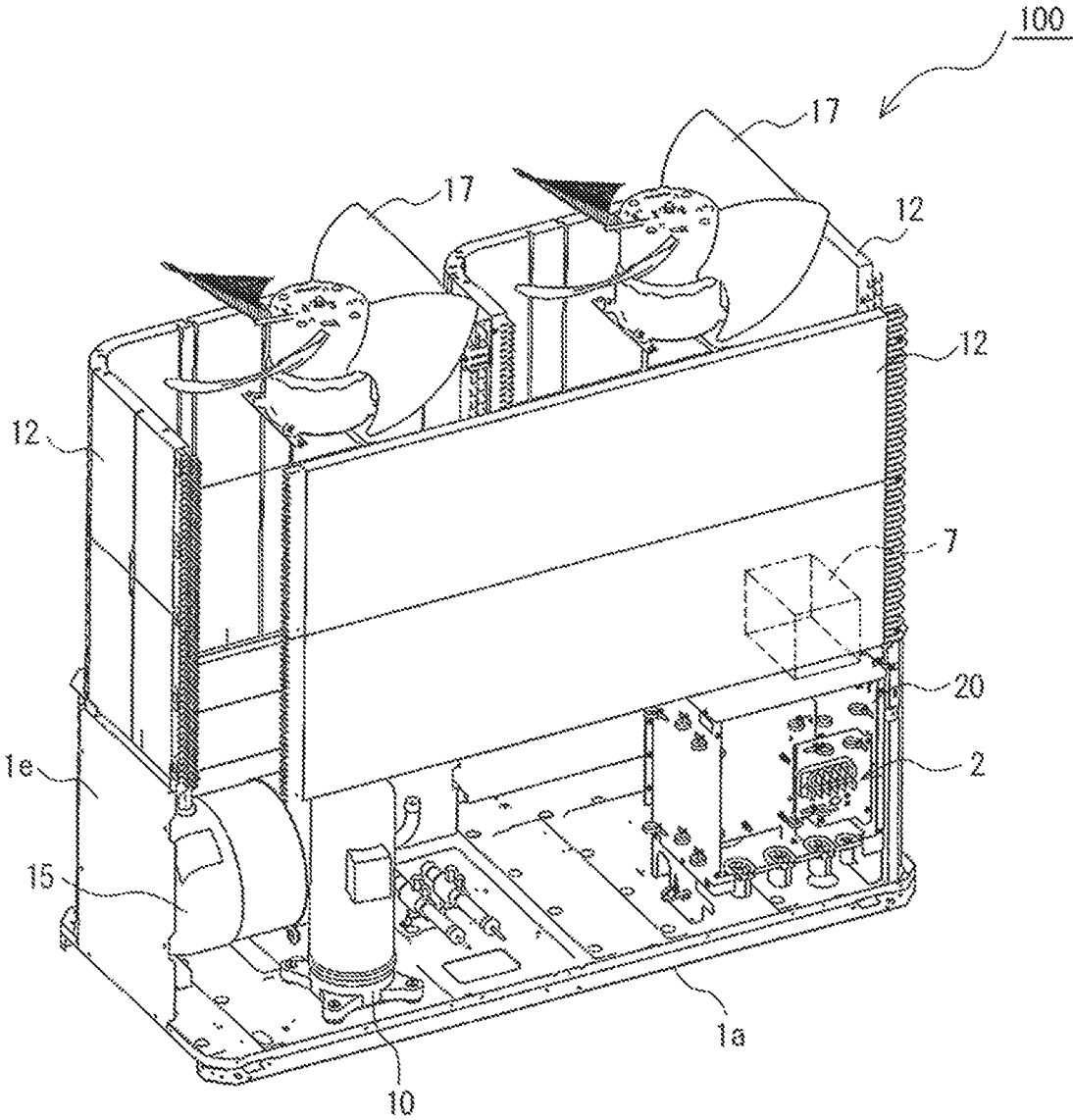

FIG. 10



## OUTDOOR UNIT OF AIR-CONDITIONING APPARATUS

### TECHNICAL FIELD

**[0001]** The present invention relates to an outdoor unit of an air-conditioning apparatus, including a harmonic suppressing unit.

### BACKGROUND ART

**[0002]** Conventionally, an outdoor unit of an air-conditioning apparatus has been known to have a configuration in which, as disclosed for example in Patent Literature 1, a chassis forming a framework contains therein a compressor, an air-sending device, and a controller that controls the compressor and the air-sending device. The controller has a configuration in which a control board with electric and electronic components mounted thereon is housed inside a housing.

### CITATION LIST

#### Patent Literature

**[0003]** Patent Literature 1: Japanese Unexamined Patent Application Publication No. 2006-317099

### SUMMARY OF INVENTION

#### Technical Problem

**[0004]** In the outdoor unit of the air-conditioning apparatus, the controller is known to include a harmonic suppressing unit, such as a reactor, to reduce power supply noise. The harmonic suppressing unit and other electric and electronic components are arranged together in the same section of the chassis. In the outdoor unit of the air-conditioning apparatus, therefore, overheating of the harmonic suppressing unit degrades the performance of the electric and electronic components and shortens their product life.

**[0005]** The present invention has been made to solve the problems described above. An object of the present invention is to provide an outdoor unit of an air-conditioning apparatus in which, even if the harmonic suppressing unit is overheated, the performance and product life of the electric and electronic components are less likely to be affected.

#### Solution to Problem

**[0006]** An outdoor unit of an air-conditioning apparatus according to an embodiment of the present invention includes a compressor, a heat exchanger, and a controller. The controller includes a compressor driving circuit configured to drive the compressor, a harmonic suppressing unit configured to suppress harmonics in the compressor driving circuit, and a housing containing the compressor driving circuit and the harmonic suppressing unit. The housing has a first section having ventilation holes that allow communication between the outside and the inside, and a second section constituting a frame outside the first section. The first section contains the harmonic suppressing unit and a fan that blows air from inside the first section to the outside through the ventilation holes. The second section contains the compressor driving circuit.

### Advantageous Effects of Invention

**[0007]** According to the embodiment of the present invention, the housing containing electric and electronic components has the first section and the second section. The electric and electronic components, such as the compressor driving circuit, whose performance and product life are significantly affected by temperature rise, are disposed in the second section. Since this enables isolation from the harmonic suppressing unit disposed in the first section, it is less likely that the performance and product life of the electric and electronic components of the controller will be affected.

### BRIEF DESCRIPTION OF DRAWINGS

**[0008]** FIG. 1 illustrates a circuit configuration of an air-conditioning apparatus according to Embodiment 1 of the present invention.

**[0009]** FIG. 2 is an external perspective view illustrating an outdoor unit of the air-conditioning apparatus according to Embodiment 1 of the present invention.

**[0010]** FIG. 3 illustrates an internal configuration of the outdoor unit of the air-conditioning apparatus according to Embodiment 1 of the present invention.

**[0011]** FIG. 4 is a block diagram illustrating a controller of the outdoor unit of the air-conditioning apparatus according to Embodiment 1 of the present invention.

**[0012]** FIG. 5 is a perspective view illustrating the controller of the outdoor unit of the air-conditioning apparatus according to Embodiment 1 of the present invention.

**[0013]** FIG. 6 is an internal configuration diagram schematically illustrating the controller of the outdoor unit of the air-conditioning apparatus according to Embodiment 1 of the present invention.

**[0014]** FIG. 7 is a diagram illustrating how a fan of the outdoor unit of the air-conditioning apparatus according to Embodiment 1 of the present invention is controlled.

**[0015]** FIG. 8 is an internal configuration diagram schematically illustrating a modification of the outdoor unit of the air-conditioning apparatus according to Embodiment 1 of the present invention.

**[0016]** FIG. 9 is a perspective view illustrating a controller of an outdoor unit of an air-conditioning apparatus according to Embodiment 2 of the present invention.

**[0017]** FIG. 10 illustrates an internal configuration of the outdoor unit of the air-conditioning apparatus according to Embodiment 2 of the present invention.

### DESCRIPTION OF EMBODIMENTS

**[0018]** Embodiments 1 and 2 of the present invention will now be described with reference to the drawings. Throughout the drawings, the same or corresponding parts are assigned the same reference numerals and their description will be omitted or simplified as appropriate. The shapes, sizes, and arrangements of components illustrated in the drawings may be appropriately changed within the scope of the present invention.

#### Embodiment 1

**[0019]** FIG. 1 illustrates a circuit configuration of an air-conditioning apparatus according to Embodiment 1 of the present invention. As illustrated in FIG. 1, an outdoor unit 100 of an air-conditioning apparatus 300 according to Embodiment 1 constitutes the air-conditioning apparatus

**300** together with an indoor unit **200** that performs indoor air conditioning. The air-conditioning apparatus **300** has a refrigerant circuit where a compressor **10**, a flow switching unit **11**, an outdoor heat exchanger **12**, an expansion mechanism **13**, an indoor heat exchanger **14**, and an accumulator **15** are connected by a refrigerant pipe **16** to allow refrigerant to circulate.

[0020] The compressor **10** compresses suctioned refrigerant and discharges the resulting high temperature and pressure refrigerant. For example, the compressor **10** is a positive displacement compressor driven by an inverter-controlled motor and configured to be capable of varying the operating capacity (frequency).

[0021] The flow switching unit **11** is, for example, a four-way valve having the function of switching the flow of refrigerant. During cooling operation, the flow switching unit **11** switches the refrigerant flow to allow connection of a refrigerant discharge side of the compressor **10** to a gas side of the outdoor heat exchanger **12**, and also to allow connection of a refrigerant suction side of the compressor **10** to a gas side of the indoor heat exchanger **14**. During heating operation, on the other hand, the flow switching unit **11** switches the refrigerant flow to allow connection of the refrigerant discharge side of the compressor **10** to the gas side of the indoor heat exchanger **14**, and also to allow connection of the refrigerant suction side of the compressor **10** to the gas side of the outdoor heat exchanger **12**. The flow switching unit **11** may be a combination of two- or three-way valves.

[0022] The outdoor heat exchanger **12** is, for example, a fin-and-tube heat exchanger that includes a heat exchanger tube and many fins. The outdoor heat exchanger **12** allows refrigerant discharged from the compressor **10** and supplied to the outdoor heat exchanger **12** to exchange heat with air blown by an outdoor air-sending device **17** and passed through the outdoor heat exchanger **12**, so that the refrigerant is cooled. The outdoor heat exchanger **12** is configured to function as a condenser during cooling operation to liquefy the refrigerant, and to also function as an evaporator during heating operation to vaporize the refrigerant.

[0023] The expansion mechanism **13** reduces pressure of the refrigerant flowing in the refrigerant circuit to expand the refrigerant. For example, the expansion mechanism **13** is constituted by an electronic expansion valve whose opening degree is variably controlled.

[0024] The indoor heat exchanger **14** functions as an evaporator during cooling operation to allow the refrigerant flowing out of the expansion mechanism **13** to exchange heat with air. The indoor heat exchanger **14** also functions as a condenser during heating operation to allow the refrigerant discharged from the compressor **10** to exchange heat with air. The indoor heat exchanger **14** draws in indoor air through an indoor air-sending device. After allowing the air to exchange heat with the refrigerant, the indoor heat exchanger **14** supplies the resulting air into the room. The accumulator **15** is disposed on the suction side of the compressor **10** and configured to store excess refrigerant circulating in the refrigerant circuit.

[0025] With reference to FIG. 1, a structure of the outdoor unit **100** of the air-conditioning apparatus **300** will be described on the basis of FIG. 2 to FIG. 7. FIG. 2 is an external perspective view illustrating an outdoor unit of the air-conditioning apparatus according to Embodiment 1 of the present invention. FIG. 3 illustrates an internal configura-

tion of the outdoor unit of the air-conditioning apparatus according to Embodiment 1 of the present invention. FIG. 4 is a block diagram illustrating a controller of the outdoor unit of the air-conditioning apparatus according to Embodiment 1 of the present invention. FIG. 5 is a perspective view illustrating the controller of the outdoor unit of the air-conditioning apparatus according to Embodiment 1 of the present invention. FIG. 6 is an internal configuration diagram schematically illustrating the controller of the outdoor unit of the air-conditioning apparatus according to Embodiment 1 of the present invention. FIG. 7 is a diagram illustrating how a fan of the outdoor unit of the air-conditioning apparatus according to Embodiment 1 of the present invention is controlled.

[0026] The outdoor unit **100** of the air-conditioning apparatus **300** has a configuration in which, as illustrated in FIG. 1 to FIG. 3, a rectangular chassis **1** forming a framework contains therein the compressor **10**, the flow switching unit **11**, the outdoor heat exchanger **12**, the expansion mechanism **13**, the outdoor air-sending device **17**, and a controller **2**.

[0027] As illustrated in FIG. 2, the chassis **1** has frame members **1b** extending upward from the corners of a bottom plate **1a** disposed at the bottom. The chassis **1** has, in its upper outer regions between adjacent ones of the frame members **1b**, air inlets **1c** for taking air into the chassis **1**. The outdoor heat exchanger **12** is disposed along the air inlets **1c**. The outdoor heat exchanger **12** is supported in the upper part of the interior of the chassis **1** by a support base disposed inside the chassis **1**. The outdoor heat exchanger **12** is a so-called four-side heat exchanger that is structured to surround a space formed therein on four sides.

[0028] As illustrated in FIG. 2 and FIG. 3, the chassis **1** has air outlets **1d** in the upper surface thereof, and the outdoor air-sending device **17** is disposed directly below the air outlets **1d**. The outdoor air-sending device **17** includes, for example, propeller fans and is driven by an air-sending device motor. By driving the outdoor air-sending device **17**, air drawn through the air inlets **1c** into the chassis **1** is passed through the outdoor heat exchanger **12** to exchange heat with the refrigerant. The air is then passed through the outdoor air-sending device **17** and discharged from the air outlets **1d**.

[0029] As illustrated in FIG. 2, the chassis **1** has, in its lower outer regions between adjacent ones of the frame members **1b**, side panels **1e** that are exterior metal plates. The lower outer regions of the chassis **1** are closed by the side panels **1e**. Although FIG. 2 shows the controller **2** that is exposed, with one of the side panels **1e** removed, the controller **2** is actually disposed inside the side panel **1e** (currently not shown). The side panels **1e** are secured to the frame members **1b** at right and left side edges thereof with fastening members, such as screws, and are also secured to the bottom plate **1a** at lower edges thereof with fastening members, such as screws. As illustrated in FIG. 3, the chassis **1** contains such components as the compressor **10**, the accumulator **15**, and the controller **2** in the lower inner part of the chassis **1** under the outdoor heat exchanger **12**. That is, the outdoor heat exchanger **12** is disposed in a separate space from the other components. To access the components for maintenance or other purposes, the side panels **1e** are removed to open up the interior of the outdoor unit **100**.

[0030] The controller **2** receives input from an AC power supply **3** to drive and control the compressor **10** and the

outdoor air-sending device 17. As illustrated in FIG. 2 and FIG. 3, the controller 2 has a configuration in which a control board with electric and electronic components mounted thereon is housed inside a housing 20. Specifically, as illustrated in FIG. 4, the controller 2 includes a noise filter 21, an AC-DC converter 22, a power supply circuit 23, an outdoor-unit control device 24, a compressor driving circuit 25, an air-sending-device driving circuit 26, and a harmonic suppressing unit 27.

[0031] The compressor driving circuit 25 includes a compressor inverter 25a that outputs, to the compressor 10, power with an output frequency and an output voltage corresponding to a command value from the outdoor-unit control device 24, and also includes an IPM driving circuit 25b that drives the compressor inverter 25a. The compressor inverter 25a is constituted, for example, by an intelligent power module (IPM) that is a semiconductor element. The compressor inverter 25a and the IPM driving circuit 25b are provided with the harmonic suppressing unit 27 therebetween. The harmonic suppressing unit 27 has the function of suppressing harmonics produced when the compressor 10 is driven during operation of the outdoor unit 100. The harmonic suppressing unit 27 is, for example, a direct-current reactor (DCL).

[0032] The air-sending-device driving circuit 26 includes an air-sending-device inverter 26a that outputs, to the air-sending device, power with an output frequency and an output voltage corresponding to a command value from the outdoor-unit control device 24, and also includes an IPM driving circuit 26b that drives the air-sending-device inverter 26a. The air-sending-device inverter 26a is constituted, for example, by an intelligent power module (IPM) that is a semiconductor element.

[0033] The housing 20 of the controller 2 is formed, for example, by metal plates. As illustrated in FIG. 5 and FIG. 6, the housing 20 has a first section A having ventilation holes 20g that allow communication between the outside and the inside, and a second section B constituting a frame outside the first section A. The first section A and the second section B are separated by a metal partitioning member 20f. The first section A is disposed below the second section B.

[0034] Specifically, the housing 20 includes a first sub-housing 20A forming the first section A and a second sub-housing 20B forming the second section B. The second sub-housing 20B is formed by a front plate 20a, right and left side plates 20b and 20c and a back plate 20d longer in the height direction than the front plate 20a, a top plate 20e, and the partitioning member 20f disposed at the lower end of the front plate 20a and configured to separate the first section A and the second section B. The second sub-housing 20B has the second section B that is a space surrounded by the front plate 20a, the right and left side plates 20b and 20c, the back plate 20d, the top plate 20e, and the partitioning member 20f and open at the front thereof. The first sub-housing 20A is disposed in the storage space C.

[0035] The second section B has no ventilation holes that allow communication between the outside and the inside, and is surrounded by metal plates. The second section B may have ventilation holes that allow communication between the outside and the inside. The housing 20 has a structure in which the internal space of the first section A and the internal

space of the second section B are separated by using, for example, a bushing to prevent entry of rain and snow and are, at the same, thermally separated.

[0036] As illustrated in FIG. 6, the first sub-housing 20A is disposed closer to the side plate 20c of the right and left side plates 20b and 20c, with the ventilation holes 20g on the suction side facing the other side plate 20b. This creates a small gap S1 between a side wall 20i on the discharge side of the first section A and the side plate 20c of the second sub-housing 20B, and also creates a large gap S2 between a side wall 20h on the inlet side of the first section A and the other side plate 20b. The harmonic suppressing unit 27 is disposed on one side of the first section A adjacent to the small gap S1, and the fan 4 is disposed on the other side of the first section A adjacent to the large gap S2. Electric wires for supplying current to the electric and electronic components in the second section B are disposed adjacent to the large gap S2. The fan 4 blows air from inside the first section A to the outside through the ventilation holes 20g formed in the opposite side walls 20h and 20i of the second section B. The fan 4 is also driven and controlled by the controller 2.

[0037] The outdoor unit 100 of the air-conditioning apparatus according to Embodiment 1 is configured such that air flowing in through the opening at the front of the storage space C is turned toward, and fed into, the first section A through the ventilation holes 20g in the side wall 20h, so that dust and other foreign particles are less likely to be drawn into the first section A. This is because if air is linearly drawn into the first section A, dust and other foreign particles inside the chassis 1 are more likely to be carried by the air, and this may cause damage to the fan 4 and the harmonic suppressing unit 27. Since there are obstacles, such as electric wires, on the side of the large gap S2, it is less likely that water or dust and other foreign particles will be directly drawn into the first section A. Since air is drawn in from the large gap S2 between the side wall 20h of the first section A and the side plate 20b of the housing 20, air is easily drawn in and this improves cooling efficiency. Note that the second section B is almost entirely surrounded by metal plates. Therefore, even when the fan 4 is internally driven, it is less likely that dust and other foreign particles will be drawn in.

[0038] Note that the housing 20 does not necessarily need to be configured as illustrated in the drawings and may have other shapes. While not shown in the drawings, the first section A may be disposed above the second section B, or may be disposed to the right or left of the second section B. The first section A and the second section B may be formed by two housings that are detached and individually disposed at a distance.

[0039] The second section B contains the noise filter 21, the AC-DC converter 22, the power supply circuit 23, the outdoor-unit control device 24, the compressor driving circuit 25, the air-sending-device driving circuit 26, and other components. Note that the noise filter 21, AC-DC converter 22, the power supply circuit 23, the outdoor-unit control device 24, and the air-sending-device driving circuit 26 are not shown in FIG. 6.

[0040] The harmonic suppressing unit 27 produces up to about 100 W of heat during operation of the outdoor unit 100. To prevent overheating of the harmonic suppressing unit 27 from degrading the functions of other components, the outdoor unit 100 drives the fan 4 to blow air from inside the first section A to the outside through the ventilation holes 20g. The outdoor unit 100 is to be used in such a manner that

the difference in temperature between the inside and outside of the first section A is less than about 50 degrees C. to 60 degrees C. In the outdoor unit 100, the electric and electronic components whose performance and product life are significantly affected by temperature rise are disposed in the second section B to be isolated from the harmonic suppressing unit 27.

[0041] As illustrated in FIG. 6, the first section A contains a temperature detecting unit 28 that detects a temperature inside the first section A. The temperature detecting unit 28 is constituted, for example, by a thermistor. As illustrated in FIG. 7, the controller 2 drives or stops the fan 4 on the basis of a determination as to whether the detection value of the temperature detecting unit 28 reaches a target value T. Specifically, if the controller 2 determines that the detection value of the temperature detecting unit 28 reaches the target value T, the controller 2 keeps driving the fan 4 to blow air from inside the first section A to the outside during the period in which the target value T is exceeded. Then, the controller 2 stops the fan 4 if it determines that the detection value of the temperature detecting unit 28 falls below the target value T. That is, the outdoor unit 100 of the air-conditioning apparatus 300 according to Embodiment 1 drives the fan 4 only when, for example, the daytime outside temperature is high and the temperature of the harmonic suppressing unit 27 rises accordingly. This extends the product life of the fan 4 and improves the energy saving effect.

[0042] As illustrated in FIG. 6, in the first section A, a conductive line 5 for supplying power to the harmonic suppressing unit 27 is disposed in contact with the side wall 20h having the ventilation holes 20g. In the outdoor unit 100, the operation of the fan 4 in wintertime may cause snow to be drawn into the first section A. If snow repeatedly hits the housing 20, the temperature of the side wall 20h having the ventilation holes 20g gradually decreases and the ventilation holes 20g may be obstructed with ice. With the ventilation holes 20g obstructed, air cannot be fully released from the first section A and this may lead to overheating. As described above, since the conductive line 5 is disposed in contact with the side wall 20h having the ventilation holes 20g, heat conducted from the harmonic suppressing unit 27 enables, for example, a temperature rise of about 7 to 8 (W). With this amount of heat, a decrease in the temperature of the side wall 20h having the ventilation holes 20g is reduced and the ventilation holes 20g are prevented from being obstructed with ice. An excessive temperature rise in the first section A caused by obstruction of the ventilation holes 20g is reduced and this also reduces a temperature rise inside the second section B.

[0043] By controlling the fan 4 on the basis of the detection value of the temperature detecting unit 28, the controller 2 may change (e.g., reverse) the direction of flow of air circulating between the outside and inside of the housing 20. If the ventilation holes 20g are obstructed, for example, with dust or ice, air inside the first section A may not be fully released to the outside by the fan 4 and may be heated to a high temperature. In the outdoor unit 100, therefore, the fan 4 is controlled to change the flow of air. The ventilation holes 20g obstructed with dust or ice are thus returned to the original state and a temperature rise in the first section A is reduced.

[0044] FIG. 8 is an internal configuration diagram schematically illustrating a modification of the outdoor unit of

the air-conditioning apparatus according to Embodiment 1 of the present invention. As illustrated in FIG. 8, the first section A contains an air-passage forming member 6 that makes the air passage gradually narrower with increasing distance from the ventilation holes 20g on the inlet side toward the harmonic suppressing unit 27. The air-passage forming member 6 is formed, for example, by an air guiding plate made of metal, and is obliquely disposed above the harmonic suppressing unit 27. By making the air passage gradually narrower with increasing distance from the ventilation holes 20g on one side toward the harmonic suppressing unit 27, the flow rate of air around the harmonic suppressing unit 27 is increased, and the harmonic suppressing unit 27 being heated is more effectively cooled. Heat from the harmonic suppressing unit 27 is radiated to the air-passage forming member 6, through which the heat is conducted to the side wall 20h of the housing 20. With this amount of heat, a decrease in the temperature of the side wall 20h having the ventilation holes 20g is reduced and the ventilation holes 20g are prevented from being obstructed with ice.

[0045] The outdoor unit 100 of the air-conditioning apparatus 300 according to Embodiment 1 includes the compressor 10, the outdoor heat exchanger 12, the outdoor air-sending device 17, and the controller 2. The controller 2 includes the compressor driving circuit 25 that drives the compressor 10, the harmonic suppressing unit 27 that suppresses harmonics in the compressor driving circuit 25, and the housing 20 that contains the compressor driving circuit 25 and the harmonic suppressing unit 27. The housing 20 has the first section A having the ventilation holes 20g that allow communication between the outside and the inside, and the second section B constituting a frame outside the first section A. The first section A contains the harmonic suppressing unit 27 and the fan 4 that blows air from inside the first section A to the outside. The second section B contains electric and electronic components whose performance and product life are significantly affected by temperature rise. In the outdoor unit 100 of the air-conditioning apparatus 300, the housing 20 containing electric and electronic components has the first section A and the second section B, and the electric and electronic components, such as the compressor driving circuit 25, whose performance and product life are significantly affected by temperature rise are disposed in the second section B. Since this enables isolation from the harmonic suppressing unit 27 disposed in the first section A, it is less likely that the performance and product life of the electric and electronic components constituting the controller 2 will be affected.

[0046] The first section A contains the temperature detecting unit 28 that detects a temperature inside the first section A. The controller 2 drives or stops the fan 4 on the basis of a determination as to whether the detection value of the temperature detecting unit 28 reaches the target value T. The outdoor unit 100 of the air-conditioning apparatus 300 according to Embodiment 1 drives the fan 4 only when, for example, the daytime outside temperature is high and the temperature of the harmonic suppressing unit 27 rises accordingly. This extends the product life of the fan 4 and improves the energy saving effect.

[0047] By controlling the fan 4 on the basis of the detection value of the temperature detecting unit 28, the controller 2 changes (e.g., reverses) the direction of flow of air circulating between the outside and inside of the housing 20.

In the outdoor unit **100** of the air-conditioning apparatus **300** according to Embodiment 1, therefore, if the ventilation holes **20g** on the inlet side are obstructed, for example, with dust or ice, the direction of air flow is changed by controlling the fan **4**. The ventilation holes **20g** are thus returned to the original state and a temperature rise in the first section A is reduced.

[0048] In the housing **20**, the first section A having the ventilation holes **20g** is formed by metal plates. In the first section A, the conductive line **5** for supplying power to the harmonic suppressing unit **27** is disposed in contact with the side wall **20h** having the ventilation holes **20g**. In the outdoor unit **100** of the air-conditioning apparatus **300**, therefore, heat conducted from the harmonic suppressing unit **27** reduces a decrease in the temperature of the side wall **20h** having the ventilation holes **20g** in wintertime, and prevents the ventilation holes **20g** from being obstructed with ice. An excessive temperature rise in the first section A is reduced and this also effectively reduces a temperature rise inside the second section B.

[0049] The first section A contains the air-passage forming member **6** that makes the air passage gradually narrower with increasing distance from the ventilation holes **20g** toward the harmonic suppressing unit **27**. The outdoor unit **100** of the air-conditioning apparatus **300** thus increases the flow rate of air around the harmonic suppressing unit **27**, and more effectively cools the harmonic suppressing unit **27** being heated.

[0050] The housing **20** includes the first sub-housing **20A** forming the first section A, and the second sub-housing **20B** forming the second section B. The second sub-housing **20B** has the front plate **20a**, the right and left side plates **20b** and **20c** and the back plate **20d** longer in the height direction than the front plate **20a**, the top plate **20e**, and the partitioning member **20f** disposed at the lower end of the front plate **20a** and configured to separate the first section A and the second section B. The space surrounded by the front plate **20a**, the right and left side plates **20b** and **20c**, the back plate **20d**, the top plate **20e**, and the partitioning member **20f** is the second section B, whereas the space located under the second section B, surrounded by the right and left side plates **20b** and **20c**, the back plate **20d**, and the partitioning member **20f**, and open at the front thereof is the storage space C. The first sub-housing **20A** is disposed in the storage space C. With this simple structure, the outdoor unit **100** of the air-conditioning apparatus **300** effectively isolates, from the harmonic suppressing unit **27**, the electric and electronic components whose performance and product life are significantly affected by temperature rise.

[0051] The first sub-housing **20A** is disposed closer to the side plate **20c** of the right and left side plates **20b** and **20c**, with the ventilation holes **20g** on the suction side facing the other side plate **20b**. The outdoor unit **100** of the air-conditioning apparatus **300** is configured such that air flowing in through the opening at the front of the storage space C is turned toward, and fed into, the first section A through the ventilation holes **20g** in the side wall **20h**. This makes it less likely that dust and other foreign particles will be drawn into the first section A.

#### Embodiment 2

[0052] The outdoor unit **100** of the air-conditioning apparatus **300** according to Embodiment 2 of the present invention will now be described on the basis of FIG. 9 and FIG.

**10**. FIG. 9 is a perspective view illustrating a controller of an outdoor unit of an air-conditioning apparatus according to Embodiment 2 of the present invention. FIG. 10 illustrates an internal configuration of the outdoor unit of the air-conditioning apparatus according to Embodiment 2 of the present invention. Note that components that are the same as those of the outdoor unit **100** of the air-conditioning apparatus **300** described in Embodiment 1 are assigned the same reference numerals and their description will be omitted as appropriate.

[0053] The controller **2** of Embodiment 2 is characterized in that a transformer **7** is mounted on an upper surface of the housing **20**. The configuration of this outdoor unit **100** of the air-conditioning apparatus **300** is effective when the transformer **7** cannot be installed inside the housing **20** due to, for example, power supply conditions at the location of installation.

[0054] In the block diagram of FIG. 4, the transformer **7** is disposed in a branch line that branches off between the AC power supply **3** and the noise filter **21** and is connected to the power supply circuit. In the branch line, for example, a control board for controlling, for example, the expansion mechanism **13** of 200 V in the outdoor unit **100** is connected in series to the transformer **7**. The transformer **7** is a voltage varying unit that varies the output power of the control board.

[0055] For example, two transformers **7** are vertically stacked and housed inside a waterproofed casing **8**. The casing **8** is secured to a securing member **9** on the upper surface of the housing **20**. The securing member **9** is formed, for example, by a steel plate and joined to the casing **8** with joining members, such as bolts. The outdoor unit **100** thus reliably stabilizes the transformer **7** installed therein and protects the transformer **7** from exposure to rain and snow. The securing member **9** is not limited to that illustrated herein, and may have any configuration that enables the casing **8** to be secured to the housing **20**.

[0056] As illustrated in FIG. 10, at least part of the transformer **7** is disposed in the space surrounded by the outdoor heat exchanger **12**. When the transformer **7** is thus disposed in the place where air flows, the transformer **7** being heated is effectively cooled.

[0057] Although the present invention has been described on the basis of Embodiments 1 and 2, the present invention is not limited to the configurations of Embodiments 1 and 2. For example, the outdoor unit **100** is not limited to that described above and may include other constituent elements. That is, the present invention includes a range of design changes and variations of application typically carried out by those skilled in the art, without departing from the scope of the technical ideas thereof.

#### REFERENCE SIGNS LIST

[0058] **1** chassis, **1a** bottom plate, **1b** frame member, **1c** air inlet, **1d** air outlet, **1e** side panel, **2** controller, **3** AC power supply, **4** fan, **5** conductive line, **6** air-passage forming member, **7** transformer, **8** casing, **9** securing member, **10** compressor, **11** flow switching unit, **12** outdoor heat exchanger, **13** expansion mechanism, **14** indoor heat exchanger, **15** accumulator, **16** refrigerant pipe, **17** outdoor air-sending device, **20** housing, **20A** first sub-housing, **20B** second sub-housing, **20a** front plate, **20b**, **20c** side plate, **20d** back plate, **20e** top plate, **20f** partitioning member, **20g** ventilation hole, **20h**, **20i** side wall, **21** noise filter, **22**



AC-DC converter, **23** power supply circuit, **24** outdoor-unit control device, **25** compressor driving circuit, **25a** compressor inverter, **25b** IPM driving circuit, **26** air-sending-device driving circuit, **26a** air-sending-device inverter, **26b** IPM driving circuit, **27** harmonic suppressing unit, **28** temperature detecting unit, **100** outdoor unit, **200** indoor unit, **300** air-conditioning apparatus, A first section, B second section

**1.** An outdoor unit of an air-conditioning apparatus, the outdoor unit comprising a compressor, a heat exchanger, and a controller,

wherein the controller includes

a compressor driving circuit configured to drive the compressor,

a harmonic suppressing unit configured to suppress harmonics in the compressor driving circuit, and

a housing containing the compressor driving circuit and the harmonic suppressing unit;

the housing has a first section having ventilation holes configured to allow communication between an outside and an inside, and a second section constituting a frame outside the first section;

the first section contains the harmonic suppressing unit and a fan configured to blow air from inside the first section to the outside through the ventilation holes; and the second section contains the compressor driving circuit.

**2.** The outdoor unit of an air-conditioning apparatus of claim **1**, wherein the first section contains a temperature detecting unit configured to detect a temperature inside the first section; and

the controller drives or stops the fan based on a determination as to whether a detection value of the temperature detecting unit reaches a target value.

**3.** The outdoor unit of an air-conditioning apparatus of claim **2**, wherein the controller controls the fan based on the detection value of the temperature detecting unit, and changes a direction of flow of air circulating between an outside and an inside of the housing.

**4.** The outdoor unit of an air-conditioning apparatus of claim **1**, wherein in the housing, the first section having the ventilation holes is formed by metal plates; and

in the first section, a conductive line for supplying power to the harmonic suppressing unit is disposed in contact with a side wall having the ventilation holes.

**5.** The outdoor unit of an air-conditioning apparatus of claim **1**, wherein the first section contains an air-passage forming member configured to make an air passage gradually narrower with increasing distance from the ventilation holes toward the harmonic suppressing unit.

**6.** The outdoor unit of an air-conditioning apparatus of claim **1**, wherein the housing includes a first sub-housing forming the first section and a second sub-housing forming the second section;

the second sub-housing has a front plate, right and left side plates and a back plate longer in a height direction than the front plate, a top plate, and a partitioning member disposed at a lower end of the front plate and configured to separate the first section and the second section;

a space surrounded by the front plate, the right and left side plates, the back plate, the top plate, and the partitioning member is the second section;

a space located under the second section, surrounded by the right and left side plates, the back plate, and the partitioning member, and open at a front thereof is a storage space; and

the first sub-housing is disposed in the storage space.

**7.** The outdoor unit of an air-conditioning apparatus of claim **6**, wherein the first sub-housing is disposed closer to one of the right and left side plates, with the ventilation holes on a suction side facing an other of the right and left side plates.

**8.** The outdoor unit of an air-conditioning apparatus of claim **1**, wherein a transformer is mounted on an upper surface of the housing.

**9.** The outdoor unit of an air-conditioning apparatus of claim **8**, wherein the transformer is housed inside a waterproofed casing; and

the casing is secured in place by a securing member disposed on the upper surface of the housing.

**10.** The outdoor unit of an air-conditioning apparatus of claim **8**, wherein the transformer is disposed in a space surrounded by the heat exchanger.

\* \* \* \* \*