

(19)



Europäisches Patentamt
European Patent Office
Office européen des brevets



(11)

EP 1 252 399 B1

(12)

EUROPEAN PATENT SPECIFICATION

(45) Date of publication and mention
of the grant of the patent:
05.07.2006 Bulletin 2006/27

(21) Application number: **01900570.1**

(22) Date of filing: **12.01.2001**

(51) Int Cl.:
E03D 3/12 (2006.01) E03D 1/14 (2006.01)

(86) International application number:
PCT/IB2001/000021

(87) International publication number:
WO 2001/053616 (26.07.2001 Gazette 2001/30)

(54) **Flushing mechanism for a dual flush cistern**

Spülmechanismus für einen Doppelspülkasten

Mécanisme de chasse d'eau pour un réservoir à double chasse

(84) Designated Contracting States:
**AT BE CH CY DE DK ES FI FR GB GR IE IT LI LU
MC NL PT SE TR**

(30) Priority: **20.01.2000 MY 0000193**

(43) Date of publication of application:
30.10.2002 Bulletin 2002/44

(73) Proprietor: **Cistern Technology Pte. Ltd
Singapore 058357 (SG)**

(72) Inventor: **HO, King Chee
47600 Subang Jaya,
Selangor (MY)**

(74) Representative: **Brereton, Paul Arthur
REDDIE & GROSE
16 Theobalds Road
London WC1X 8PL (GB)**

(56) References cited:
US-A- 5 331 690 US-A- 5 956 781

EP 1 252 399 B1

Note: Within nine months from the publication of the mention of the grant of the European patent, any person may give notice to the European Patent Office of opposition to the European patent granted. Notice of opposition shall be filed in a written reasoned statement. It shall not be deemed to have been filed until the opposition fee has been paid. (Art. 99(1) European Patent Convention).

Description

[0001] This invention relates to a flushing mechanism for a dual flush cistern.

BACKGROUND TO THE INVENTION

[0002] In recent years it has, in many countries, been a requirement that all new toilet cisterns installed should have a dual-flush function, in which a full flush releasing a large quantity of flushing liquid can be used when solid waste is to be disposed of and a partial flush releasing a smaller quantity of flushing liquid can be used when a full flush is not required for example when liquid waste is to be disposed of.

Many such mechanisms for dual flush cisterns have been proposed

[0003] In certain systems the cistern is divided into two parts by a weir having a movable gate such that when a partial flush is required the gate remains closed and only the liquid on one side of the weir is released through the cistern outlet but when a full flush is required the gate is opened allowing liquid on both sides of the weir to pass through the outlet. Examples of such dual flush mechanisms are disclosed in AU-B-56165/80 and WO93/15284.

[0004] Another type of dual flushing mechanism relies on closing the outlet valve after different times depending on whether a full or partial flush is required.

[0005] Examples of such mechanism are described for example, in AU-A-28538/84, AU-B-80111/87, AU-B-40396/85 and WO93/15284.

[0006] The prior art mechanisms generally include a float assembly comprising a float associated with the valve stem of the outlet closure valve and either attached to or slideable on the valve stem. The float reduces the negative buoyancy of the float assembly so that the float assembly sinks at a slower rate to close the valve than it would do if the float were not present.

[0007] The majority of the prior art mechanisms include a large number of moving parts and are complicated in their structure in that various non-linear motions are involved in operation of the valve.

[0008] It is the object of this invention to provide a flushing mechanism for a dual flush cistern that is very much simpler than the existing mechanisms.

SUMMARY OF THE INVENTION

[0009] This invention provides a dual flush system comprising a float assembly comprising a hollow valve stem carrying a sealing valve for sealing the outlet opening of the cistern at or towards one end and being open at each end to define an overflow passage and a float fixedly attached around the valve stem, a cylindrical guide member surrounding the float and having at the

end adjacent the sealing valve at least one opening to allow liquid to pass to the outlet opening, an operating rod arranged to move vertically upward to raise the float assembly to open the valve, first and second operating means arranged to effect such vertical movement of the operating rod, the first operating means, on operation, being arranged to raise the float assembly a first distance, and the second operating means being arranged to raise the float assembly a second distance less than the first distance, whereby when the first operating means is operated and released, a first-predetermined quantity of liquid flows from the cistern, and when the second operating means is operated and released a second, smaller, pre-determined quantity of liquid flows from the cistern.

[0010] The float preferably comprises an inverted cup-shaped member which traps air, thereby reducing the negative buoyancy of the float assembly. The rate of closing of the valve is dependent on the hydrostatic pressure acting on the float and on the distance that the float has to move to close the valve. Thus, the float assembly is designed so that when the float assembly is raised by the first, full flushing, distance the float is buoyant and so falls to close the valve as the level of the liquid supporting it drops thereby allowing the predetermined quantity of liquid to flow from the cistern. However, when it is raised by the second partial flushing, distance the hydrostatic pressure on the float surface is such that the float is not buoyant and the valve starts to close as soon as the operating means is released, the rate of closure being such that the second predetermined amount of liquid flows from the cistern.

[0011] In some instances for example when the operating means is held down for too long a time or is operated too violently the water level in the cistern may drop so far or the float assembly may gain sufficient momentum to move further upward than the second predetermined distance that the assembly may become buoyant. Preferably, therefore, the second operating means on operation, in addition to raising the float assembly also operates a stop mechanism acting on some part of the float assembly to prevent movement of the float assembly greater than the second distance. In its simplest form, such stop mechanism comprises a rod which, on operation of the second operating means, is introduced into the float guide member to a predetermined level to contact the upper surface of the float when the float has reached the desired height. Preferably, the stop mechanism is adjustable to allow fine-tuning of the quantity of liquid that flows from the cistern in a partial flush. This may be achieved by means of a screw thread on the rod by means of which the lower end of the rod can be raised or lowered relative to the float. The rod preferably passes through a guide member mounted on the rim of the float guide member in order to constrain movement of the rod only to an up and down movement.

[0012] The operating means preferably comprises a pair of push buttons or the top of the tank, depression of which moves a pivoted lever which is connected to the

operating rod. However, especially when the mechanism is intended for use as a conversion kit for an existing lever operated cistern the operating means may comprise a pair of levers for example mounted on concentric shafts with appropriate linkages to the operating rod.

[0013] The operating mechanism is preferably carried on a crocket which is mounted on the side of the float guide means the length of which is preferably adjustable to allow the mechanism to be used in cisterns of different height, In a mechanism in which the length of the bracket is adjustable the length of the operating rod and of the stop rod when present must also be adjustable.

[0014] In a preferred form of the operating mechanism the connection between the operating means and the float assembly comprises a rod or car with a plurality of spaced holes at least at its end adjacent to the float assembly which cooperates with a bracket on the float guide member which also has at least one hole through which a fixing pin can be passed into one of the holes on the bracket. The operating rod and the stop rod may be telescopic and may be held together by locating pins which can pass through locating holes as necessary. In the case of the stop rod, the rod is preferably mounted in a U-shaped rod carrier and the locating pins are permanently attached to the rod so that the rod can be rotated to snap the pin into and out of one of a plurality of notches on the rod carrier. The rod carrier may be mounted by a screw thread on the second operating means to allow fine adjustment of the effective length of the rod.

DESCRIPTION OF PREFERRED EMBODIMENT

[0015] The invention will now be described in greater detail by way of example with reference to the drawings, in which: -

Fig. 1 is an isometric view of one form of flushing mechanism according to the invention in the closed position of the valve;

Fig. 2 is an isometric view of the valve mechanism of fig. 1 in the full flush position;

Fig. 3 is an isometric view of the mechanism of fig. 1 in the partial flush position;

Fig. 4 is a section through the mechanism of fig. 1 in the full flush position but with the stop rod not shown; and

Fig. 5 is a view as in fig. 4 but in the partial flush position.

[0016] As shown in the drawings, the flushing mechanism comprises a float assembly indicated generally by reference numeral 1 which comprises a valve stem 2 which is hollow and open at both ends and carries towards one end a valve closure member 3 which seats on a valve seat 4 on a fixture member 5 by which the float assembly 1 is mounted to the outlet 1 (not shown) of a toilet system also not shown). Float assembly 1 also includes a float 6 in the form of an inverted cup member

which is fixedly attached around valve stem 2. Float 6 is closely surrounded by a cylindrical portion 7 of a float guide 8. Cylindrical portion 7 is spaced from the bottom of the cistern and the valve seat by means of legs 9 on a spacer member 10 which is attached to cylindrical portion 7 by a bayonet fixing 11 at one end and at the other end is attached to fixture member 5. The base of cylindrical portion 7 is closed to limit the maximum movement of float assembly 1

[0017] On its outer surface, cylindrical portion 7 carries a bracket 12 for mounting a support arm 13 for the flush operating mechanism. The support arm 13 is cranked at its upper end 14 and terminates in a yoke 15 supporting a pivotally mounted operating lever 16. One end of lever 16 is attached to a cranked operating rod 17 which extends into cylindrical portion 7 the portion within cylindrical portion 7 being attached to valve stem 2 by means of a collar 18 which abuts against the underside of a flange 19 on valve stem 2. Collar 18 is attached to operating rod 15 by means of a pin 20 which passes into one of a number of holes 21 in operating rod 17. Downward pressure on the end of lever 16 remote from the connection of operating rod 17 causes operating rod 17 to move upwardly carrying the float assembly 1 with it and thereby, causing the valve 3, 4 to open to allow liquid to exit the cistern.

[0018] Support arm 13 is connected to bracket 12 by means of locking pins (not shown) engaging in one or more of holes 22 in supporting arm 13 so that the distance between the operating mechanism and the float assembly 1 can be varied to suit cisterns of different height. Operating rod 17 is formed in two parts connected by means of pins 23 locating in holes 24 in the two parts of the operating rod 17 thereby allowing length adjustment of operating rod 17.

[0019] The operating mechanism includes two push buttons 25, 26 which serve to depress the end of lever 16 remote from the connection of operating rod 17.

[0020] The push buttons 25, 26, are spring loaded so that they are biased to an inoperative position.

[0021] Each of push buttons 25, 26 has a projection 27, 28 on its lower surface which when a button 25, 26 is pressed acts on lever 16 to move operating rod 17 upwardly. Projection 27 on the full flush button 26 is longer than the projection 28 on partial flush button 26, so that when push button 25 is pressed, the operating rod 17 is lifted by a greater distance and hence lifts the float assembly further away from the valve seat 6 than when push button 26 is pressed.

[0022] The projection 28 on push button 26 is connected to a further lever 29 which at one end 30 overlaps the operative end of lever 16 and at the other end 31 is attached to a stop rod 32 via a U-shaped rod carrier 33. Stop rod 32 passes through a guide 34 on the rim of cylindrical portion 7. Depression of button 26 causes projection 28. in addition to causing operating rod 16 to move upwardly thereby raising the float assembly 1, also depresses stop rod 33 within cylindrical portion 7 to further

limit the possible movement of float assembly 1.

[0023] Rod carrier 31 is attached to lever 29 by means of a screw 34 which passes through a screw-threaded bore in end 31 of lever 29 to allow adjustment of the distance between rod carrier 33 and lever 29 thereby allowing fine tuning of the distance that rod 32 extends into cylindrical portion 7. In addition carrier member 33 has a plurality of notches 35 into which a pin 36 protruding from the surface of rod 32 can be snapped, to allow larger adjustment of the effective length of rod 31.

[0024] As shown in fig. 4, in the full flush position float assembly 1 is raised by means of operating rod 17 to a level such that the top of float 6 almost reaches the upper edge of cylindrical portion 7. At this level the air trapped under float 6 is sufficient to make float assembly 1 buoyant so that the float assembly 1 does not sink under its own weight when push button 25 is released but instead merely falls as the water level in the cistern drops.

[0025] As shown in Fig. 5, in the partial flush portion, float assembly 1 is raised to a lesser level. At this lower level the hydrostatic pressure acting on float 6 is sufficient to overcome the buoyancy of float assembly 1 so that when push button 26 is released, the float assembly 1 will sink under its own weight albeit at a slower rate than it would if the float 6 were not present.

Claims

1. A flushing mechanism for a dual flush cistern system comprising a float assembly (1) comprising a hollow valve stem (2) carrying a sealing valve (3) for sealing the outlet opening of the cistern at or towards one end and being open at each end to define an overflow passage and a float (6) fixedly attached around the valve stem (2), a cylindrical guide member (7) surrounding the float (6) and having at the end adjacent the sealing valve at least one opening to allow liquid to pass to the outlet opening an operating rod (17) arranged to move vertically upward to raise the float assembly (1) to open the valve (3), first and second operating means (25, 26) arranged to effect such vertical movement of the operating rod (17) **characterized in that**, the first operating means (25) on operation is arranged to raise the float assembly (1) a first distance to a level which the float assembly (1) is buoyant, and the second operating means (26) is arranged to raise the float assembly (1) a second distance, less than the first distance to a level at which the float assembly (1) is not buoyant, whereby when the first operating means (25) is operated and released, a first predetermined quantity of liquid flows from the cistern and when the second operating means (26) is operated and released a second, smaller predetermined quantity of liquid flows from the cistern.
2. A mechanism according to claim 1, wherein the float

(6) comprises an inverted cup-shaped member which traps air thereby reducing the negative buoyancy of the float assembly (1).

3. A mechanism according to claim 1 or claim 2, wherein the second operating means (26) on operation in addition to raising the float assembly (1) also operates a stop mechanism (32, 33) acting on some part of the float assembly (1) to prevent movement of the float assembly (1) greater than the second distance.
4. A mechanism according to claim 3, wherein the stop mechanism (32, 33) comprises a rod (32) which on operation of the second operating means (26) is introduced into the float guide member (7) to a predetermined level to contact the upper surface of the float (6) when the float (6) has reached the desired height.
5. A mechanism according to claim 4, wherein the stop mechanism (32, 33) is adjustable to allow fine-tuning of the quantity of liquid that flows from the cistern in a partial flush.
6. A mechanism according to claim 4 or claim 5 wherein the rod (32) passes through a guide member (34) mounted on the rim of the float guide member (7) to constrain movement of the rod (32) only to an up and down movement.
7. A mechanism according to anyone of claims 1 to 6, wherein the operating means (25, 26) comprises a pair of push buttons on the top of the cistern depression of which moves a pivoted lever (16) which is connected to the operating rod (17).
8. A mechanism according to anyone of claims 1 to 7, wherein the operating mechanism is carried on a bracket (13) which is mounted on the side of the float guide means (7), the length of the bracket 13 being adjustable to allow the mechanism to be used in cisterns of different height the length of the operating rod (17) and of the stop rod (32, 33), when present being also adjustable.

Patentansprüche

1. Spülmechanismus für ein Zwei-Mengen-Spülkastensystem, der Folgendes umfasst: eine Schwimmerbaugruppe (1), die einen hohlen Ventilschaft (2), der ein Verschlussventil (3) zum dichten Verschließen der Auslassöffnung des Spülkastens an einem oder in Richtung auf ein Ende trägt und an jedem Ende offen ist, um einen Überlaufkanal zu definieren, und einen um den Ventilschaft (2) fest angebrachten Schwimmer (6) umfasst, ein zylindrisches Führungselement (7), das den Schwimmer (6) umgibt und an

dem Ende neben dem Verschlussventil wenigstens eine Öffnung hat, um Flüssigkeit zu der Auslassöffnung passieren zu lassen, eine Betätigungsstange (17), die angeordnet ist, um sich zum Heben der Schwimmerbaugruppe (1) zum Öffnen des Ventils (3) vertikal nach oben zu bewegen, ein erstes und ein zweites Betätigungsmittel (25, 26), die zum Bewirken einer solchen vertikalen Bewegung der Betätigungsstange (17) angeordnet sind, **dadurch gekennzeichnet, dass** das erste Betätigungsmittel (25) bei Betätigung zum Heben der Schwimmerbaugruppe (1) um eine erste Entfernung auf ein Niveau, auf dem die Schwimmerbaugruppe (1) schwimmfähig ist, angeordnet ist und das zweite Betätigungsmittel (26) zum Heben der Schwimmerbaugruppe (1) um eine zweite Entfernung, die kleiner ist als die erste Entfernung, auf ein Niveau, auf dem die Schwimmerbaugruppe (1) nicht schwimmfähig ist, angeordnet ist, wodurch beim Betätigen und Freigeben des ersten Betätigungsmittels (25) eine erste vorbestimmte Flüssigkeitsmenge aus dem Spülkasten fließt und beim Betätigen und Freigeben des zweiten Betätigungsmittels (26) eine kleinere vorbestimmte Flüssigkeitsmenge aus dem Spülkasten fließt.

2. Mechanismus nach Anspruch 1, bei dem der Schwimmer (6) ein umgekehrtes becherförmiges Element umfasst, in dem Luft eingeschlossen wird, wodurch der Abtrieb der Schwimmerbaugruppe (1) verringert wird.
3. Mechanismus nach Anspruch 1 oder Anspruch 2, bei dem das zweite Betätigungsmittel (26) bei Betätigung zusätzlich zum Anheben der Schwimmerbaugruppe (1) auch einen Anschlagmechanismus (32, 33) betätigt, der auf irgendeinen Teil der Schwimmerbaugruppe (1) wirkt, um zu verhindern, dass sich die Schwimmerbaugruppe (1) weiter als um die zweite Entfernung bewegt.
4. Mechanismus nach Anspruch 3, bei dem der Anschlagmechanismus (32, 33) eine Stange (32) umfasst, die bei Betätigung des zweiten Betätigungsmittels (26) bis auf ein vorbestimmtes Niveau in das Schwimmerführungselement (7) eingeführt wird, um die Oberseite des Schwimmers (6) zu berühren, wenn der Schwimmer (6) die gewünschte Höhe erreicht hat.
5. Mechanismus nach Anspruch 4, bei dem der Anschlagmechanismus (32, 33) einstellbar ist, um die Feineinstellung der Flüssigkeitsmenge zu ermöglichen, die bei einer Teilspülung aus dem Spülkasten fließt.
6. Mechanismus nach Anspruch 4 oder Anspruch 5, bei dem die Stange (32) durch ein Führungselement (34) verläuft, das am Rand des Schwimmerfüh-

rungelements (7) angebracht ist, um die Bewegung der Stange (32) auf nur eine Auf- und Abbewegung zu beschränken.

- 5 7. Mechanismus nach einem der Ansprüche 1 bis 6, bei dem die Betätigungsmittel (25, 26) ein Paar Druckknöpfe oben an dem Spülkasten umfassen, wobei beim Drücken dieser ein Gelenkhebel (16) bewegt wird, der mit der Betätigungsstange (17) verbunden ist.
- 10
8. Mechanismus nach einem der Ansprüche 1 bis 7, bei dem der Betätigungsmechanismus auf einem Halter (13) getragen wird, der an der Seite des Schwimmerführungsmittels (7) angebracht ist, wobei die Länge des Halters (13) einstellbar ist, damit der Mechanismus in Spülkästen verschiedener Höhe verwendet werden kann, wobei die Länge der Betätigungsstange (17) und der Anschlagstange (32, 33), wenn vorhanden, ebenfalls einstellbar ist.
- 15
- 20

Revendications

- 25 1. Mécanisme de chasse pour système de citerne à double chasse comprenant un ensemble de flotteur (1) comprenant une tige de vanne creuse (2) portant un clapet de fermeture (3) pour fermer l'ouverture d'échappement de la citerne au niveau d'une extré-
- 30 mité, ou vers une extrémité, et ouverte à chaque extrémité pour définir un passage de trop-plein et un flotteur (6) monté de manière fixe autour de la tige de vanne (2), un élément de guidage cylindrique (7) entourant le flotteur (6) et comportant au niveau de l'extrémité adjacente au clapet de fermeture au
- 35 moins une ouverture pour laisser passer le liquide jusqu'à l'ouverture d'échappement, une tige d'actionnement (17) disposée pour se déplacer verticalement vers le haut pour faire monter l'ensemble de
- 40 flotteur (1) afin d'ouvrir le clapet (3), des premier et deuxième moyens d'actionnement (25, 26) agencés pour effectuer un tel mouvement vertical de la tige d'actionnement ((17) **caractérisé en ce que** le premier moyen d'actionnement (25) lors de son fon-
- 45 tionnement est disposé pour faire monter l'ensemble de flotteur (1) par une première distance jusqu'à un niveau où l'ensemble de flotteur (1) flotte et le deuxième moyen d'actionnement (26) est disposé pour faire monter l'ensemble de flotteur (1) par une deuxième
- 50 distance, inférieure à la première distance jusqu'à un niveau où l'ensemble de flotteur (1) ne flotte pas, par lequel quand le premier moyen d'actionnement (25) est actionné et libéré, une première quantité prédéterminée de liquide s'écoule de la citerne,
- 55 et quand le deuxième moyen d'actionnement (26) est actionné et libéré, une deuxième quantité prédéterminée inférieure de liquide s'écoule de la citerne.

2. Mécanisme selon la revendication 1, dans lequel le flotteur (6) comprend un élément en forme de coupelle inversée qui emprisonne l'air, réduisant ainsi la flottabilité négative de l'ensemble de flotteur (1). 5
3. Mécanisme selon la revendication 1 ou la revendication 2, dans lequel le deuxième moyen d'actionnement (26) lors de son fonctionnement, en plus de faire monter l'ensemble de flotteur (1) actionne également un mécanisme d'arrêt (32, 33) qui agit sur une certaine partie de l'ensemble de flotteur (1) afin d'empêcher le mouvement de l'ensemble de flotteur (1) par plus de la seconde distance. 10
4. Mécanisme selon la revendication 3, dans lequel le mécanisme d'arrêt (32, 33) comprend une tige (32) qui, lors du fonctionnement du second moyen d'actionnement (26) est introduite dans l'élément de guidage de flotteur (7) jusqu'à un niveau prédéterminé afin de faire contact avec la surface supérieure du flotteur (6) quand le flotteur (6) a atteint la hauteur désirée. 15 20
5. Mécanisme selon la revendication 4, dans lequel le mécanisme d'arrêt (32, 33) est ajustable pour régler finement la quantité de liquide qui s'écoule de la citerne lors d'une chasse partielle. 25
6. Mécanisme selon la revendication 4 ou la revendication 5, dans lequel la tige (32) passe à travers un élément de guidage (34) monté sur le bord de l'élément de guidage de flotteur (7) afin de limiter le mouvement de la tige (32) à un seul mouvement de montée et de descente. 30 35
7. Mécanisme selon l'une quelconque des revendications 1 à 5, dans lequel le moyen d'actionnement (25, 26) comprend une paire de boutons poussoirs sur le dessus de la citerne, la pression desquels déplace un levier pivotant (16) qui est raccordé à la tige d'actionnement (17). 40
8. Mécanisme selon l'une quelconque des revendications 1 à 7, dans lequel le mécanisme d'actionnement est porté sur une potence (13) qui est montée sur le côté du moyen de guidage de flotteur (7), la longueur de la potence 13 étant réglable pour permettre d'utiliser le mécanisme dans des citernes d'une hauteur différente, la longueur de la tige d'actionnement (17) et de la tige d'arrêt (32, 33), quand elle est présente, étant aussi réglables. 45 50

55

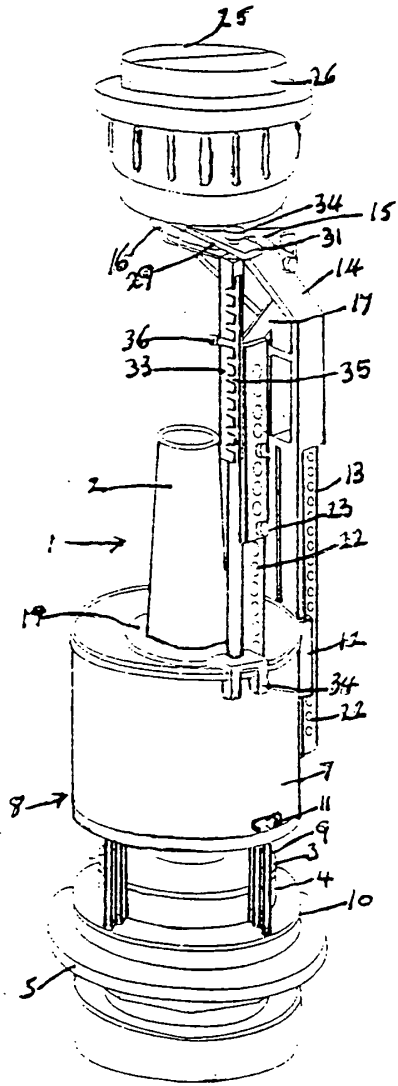

Fig 1

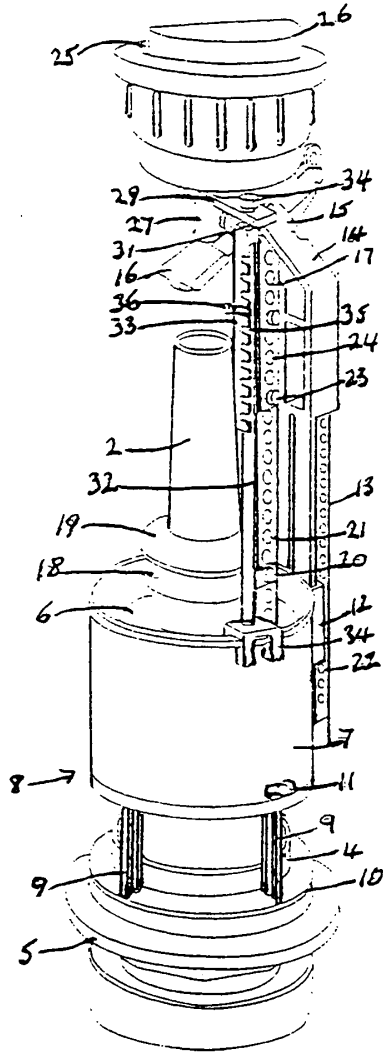

Fig 2

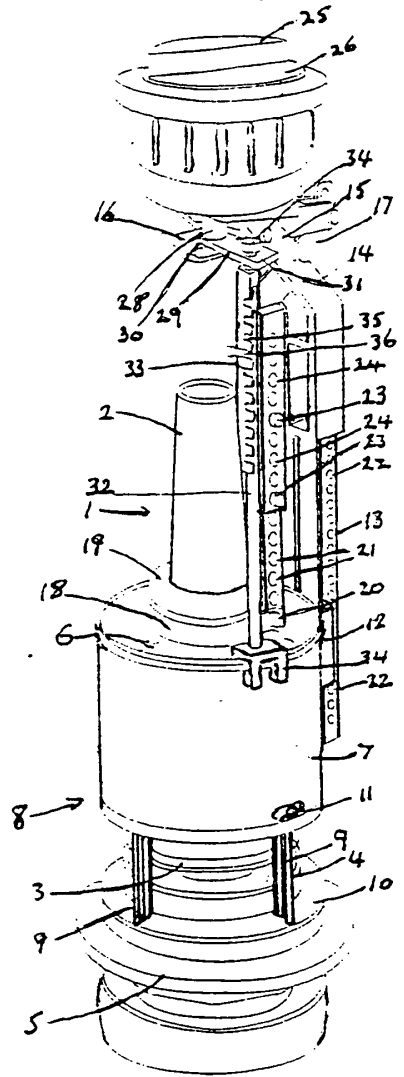

Fig 3

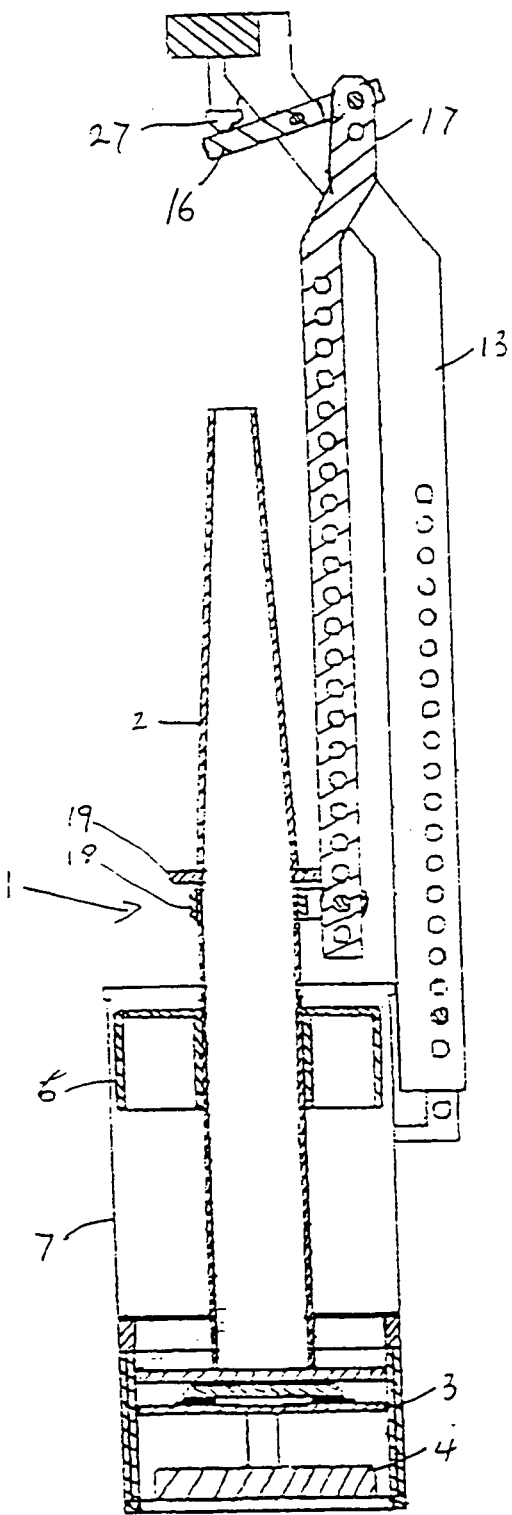

Fig 4

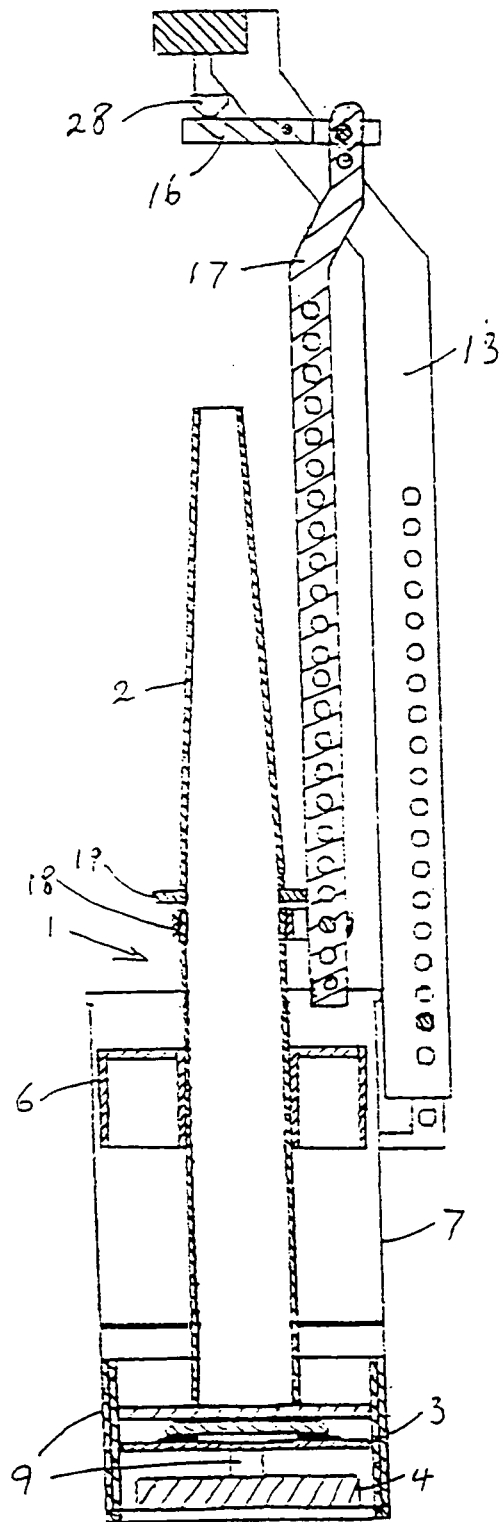

Fig 5