



(19) **United States**

(12) **Patent Application Publication**

**Yee et al.**

(10) **Pub. No.: US 2021/0015411 A1**

(43) **Pub. Date: Jan. 21, 2021**

(54) **ANALYTE SENSOR AND APPARATUS FOR INSERTION OF THE SENSOR**

**Publication Classification**

(71) Applicant: **ABBOTT DIABETES CARE INC.**,  
Alameda, CA (US)

(51) **Int. Cl.**

- A61B 5/1486* (2006.01)
- A61B 5/00* (2006.01)
- A61B 5/0205* (2006.01)
- G06K 7/10* (2006.01)
- A61B 5/145* (2006.01)
- A61M 5/158* (2006.01)
- A61M 5/172* (2006.01)

(72) Inventors: **Phillip Yee**, San Francisco, CA (US);  
**Christopher A. Thomas**, San Leandro, CA (US);  
**Udo Hoss**, Castro Valley, CA (US);  
**Lei He**, Moraga, CA (US);  
**Michael R. Love**, Pleasanton, CA (US)

(52) **U.S. Cl.**

- CPC ..... *A61B 5/14865* (2013.01); *A61M 5/3286* (2013.01); *A61B 5/02055* (2013.01); *G06K 7/10366* (2013.01); *A61B 5/14532* (2013.01); *A61M 5/158* (2013.01); *A61B 5/002* (2013.01); *A61B 5/6849* (2013.01); *A61B 5/0004* (2013.01); *A61B 5/0024* (2013.01); *A61B 5/6898* (2013.01); *A61B 5/72* (2013.01); *A61B 5/7425* (2013.01); *A61M 5/1723* (2013.01); *A61B 5/14503* (2013.01); *A61B 5/742* (2013.01); *A61B 5/7405* (2013.01); *A61B 5/7455* (2013.01); *A61B 5/0022* (2013.01)

(21) Appl. No.: **17/033,588**

(22) Filed: **Sep. 25, 2020**

**Related U.S. Application Data**

(63) Continuation of application No. 16/736,728, filed on Jan. 7, 2020, now Pat. No. 10,786,190, which is a continuation of application No. 15/994,129, filed on May 31, 2018, which is a continuation of application No. 15/475,647, filed on Mar. 31, 2017, now Pat. No. 9,993,188, which is a continuation of application No. 15/192,531, filed on Jun. 24, 2016, now Pat. No. 9,636,068, which is a continuation of application No. 12/698,129, filed on Feb. 1, 2010, now Pat. No. 9,402,544.

(57)

**ABSTRACT**

(60) Provisional application No. 61/149,639, filed on Feb. 3, 2009.

An apparatus for insertion of a medical device in the skin of a subject is provided.

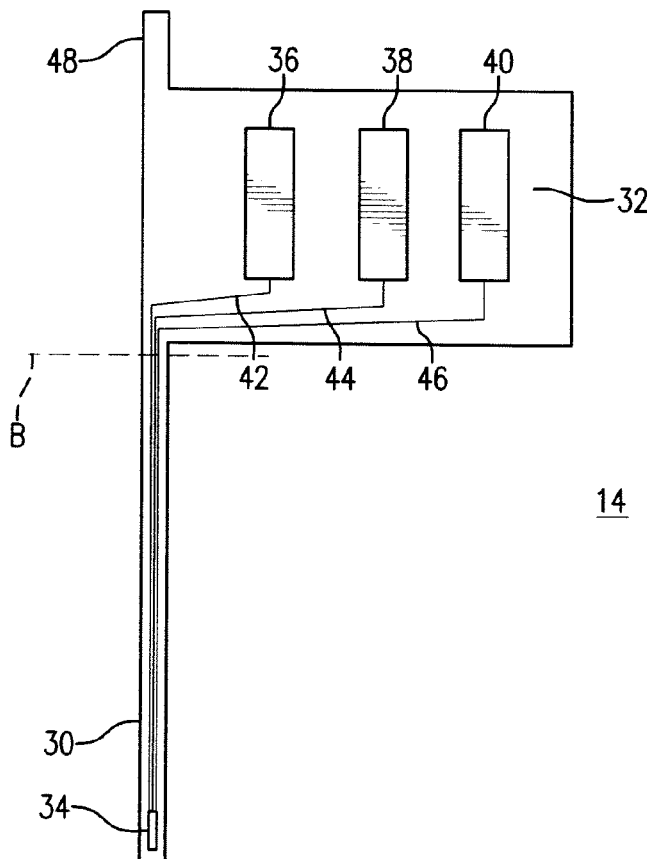

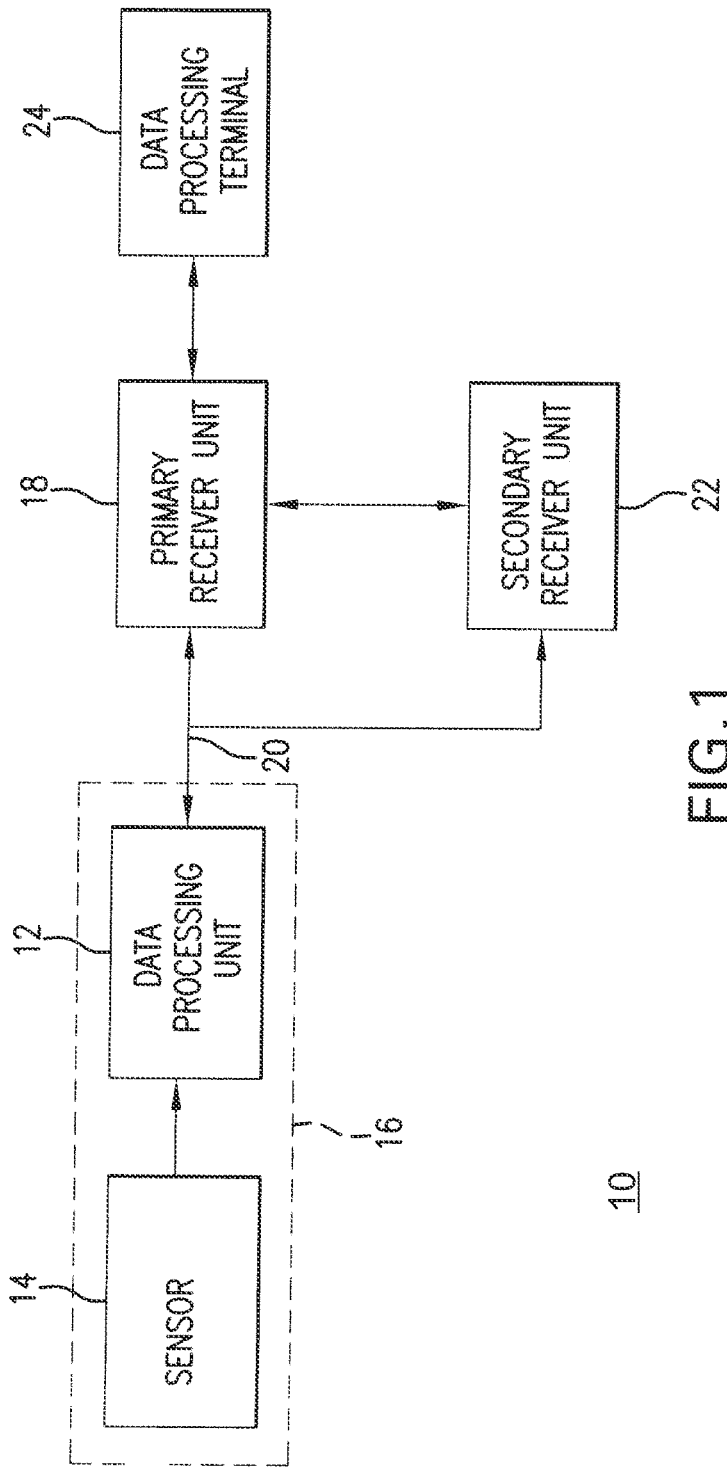
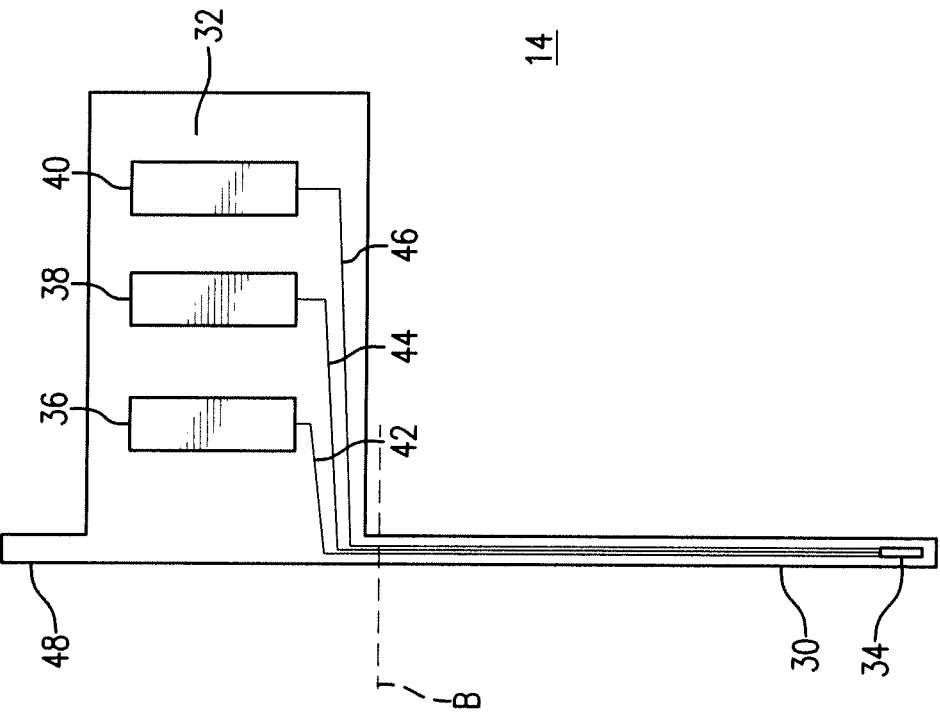

FIG. 1

10



14

FIG. 2

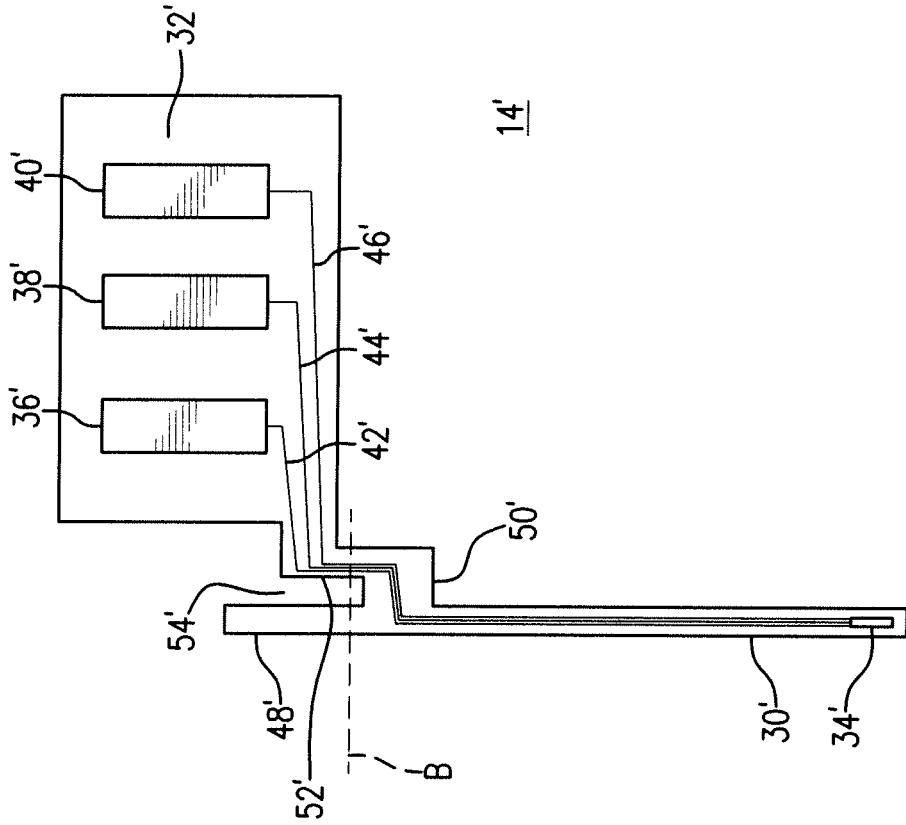

FIG.3

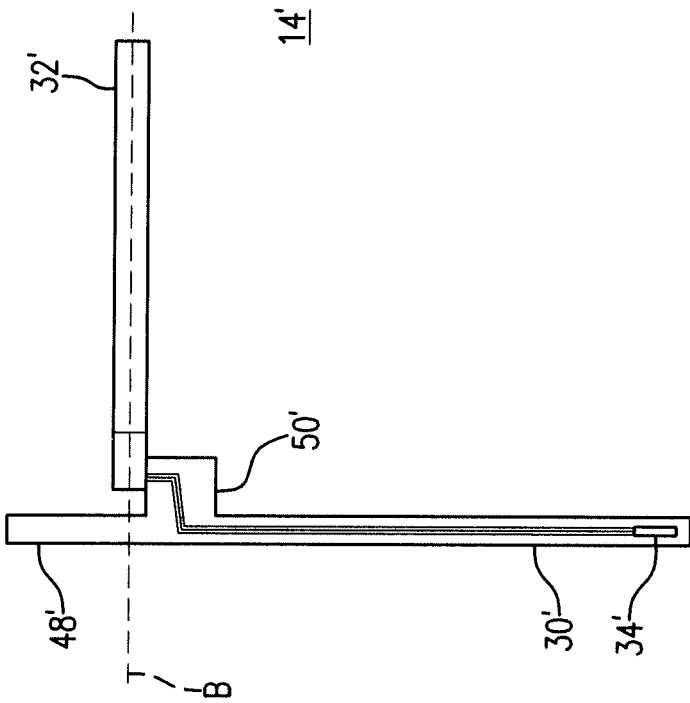

FIG.4

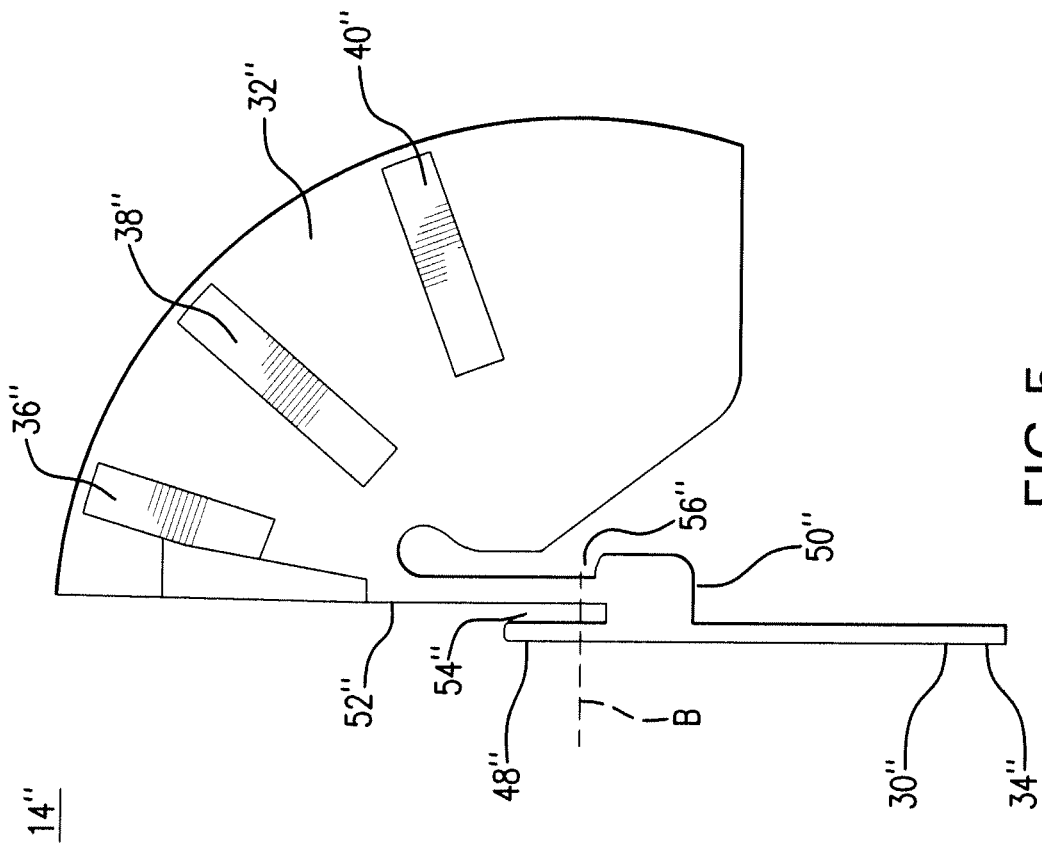

FIG. 5

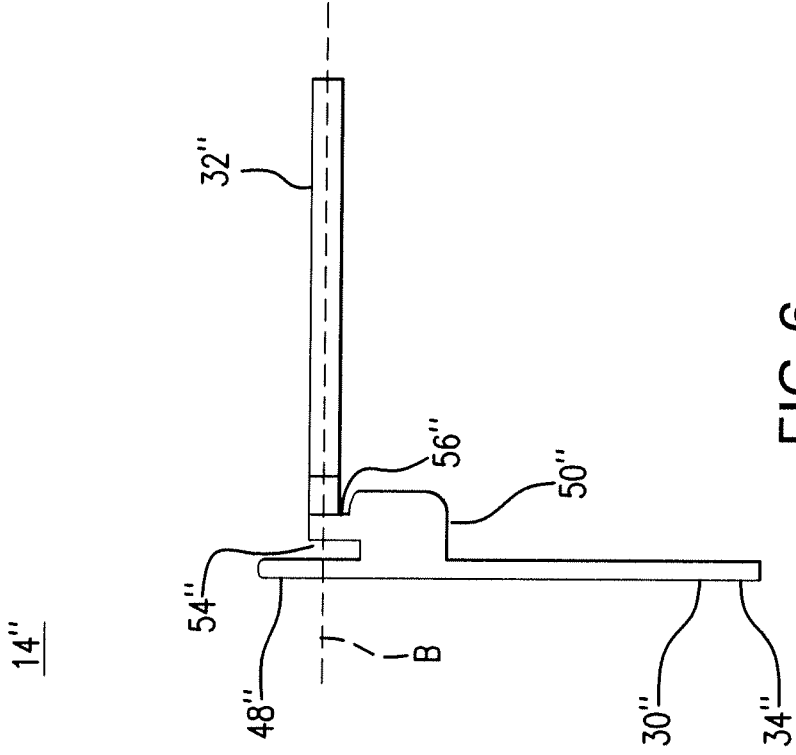

FIG.6

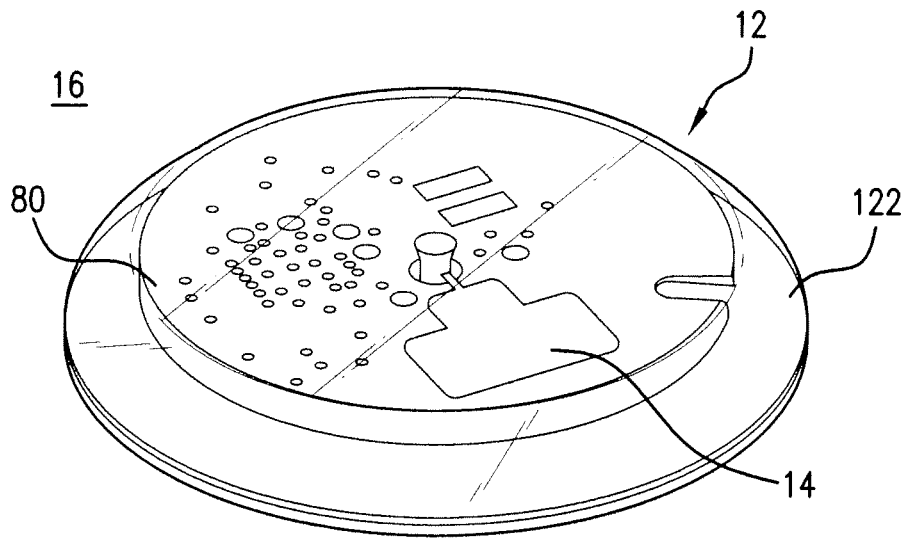

FIG. 7

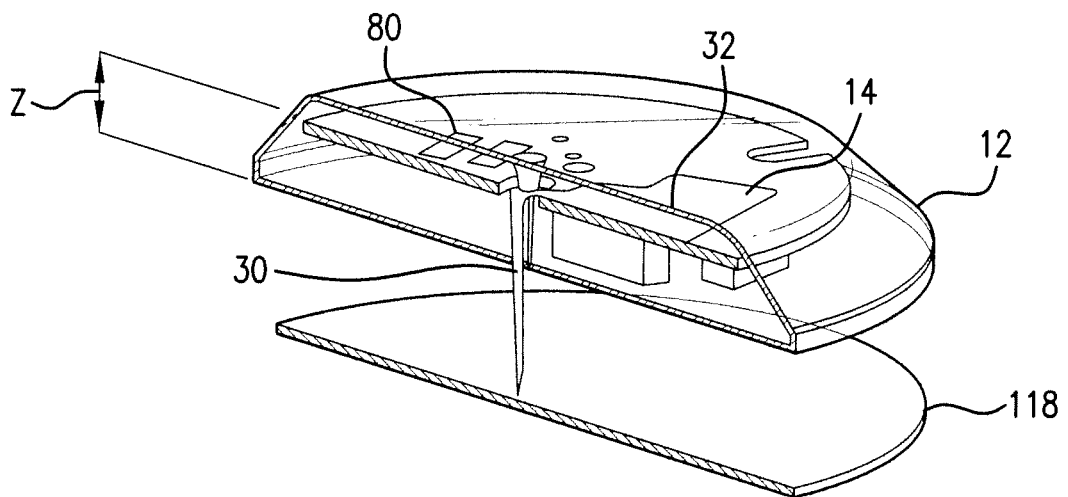

FIG. 8



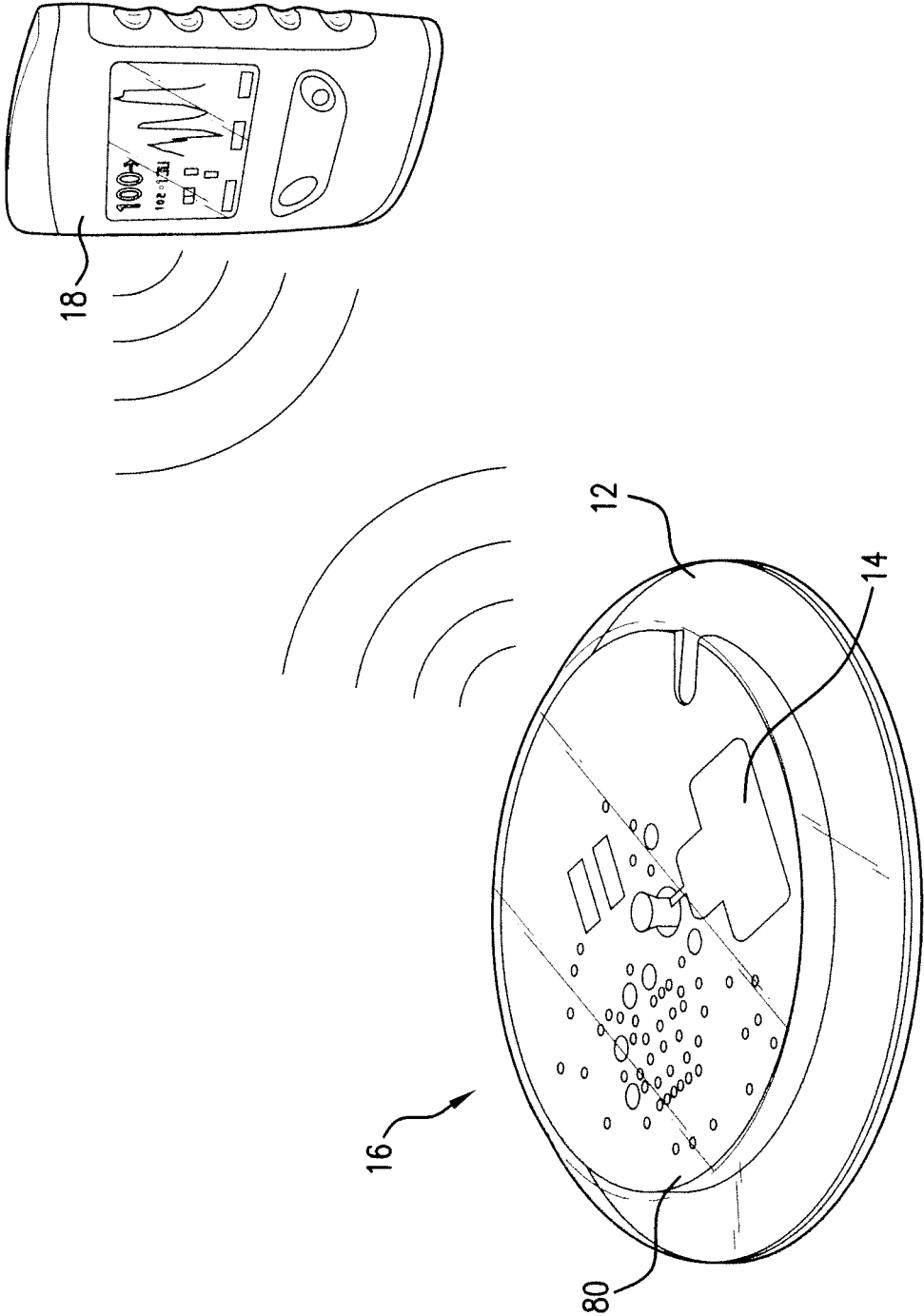

FIG. 9

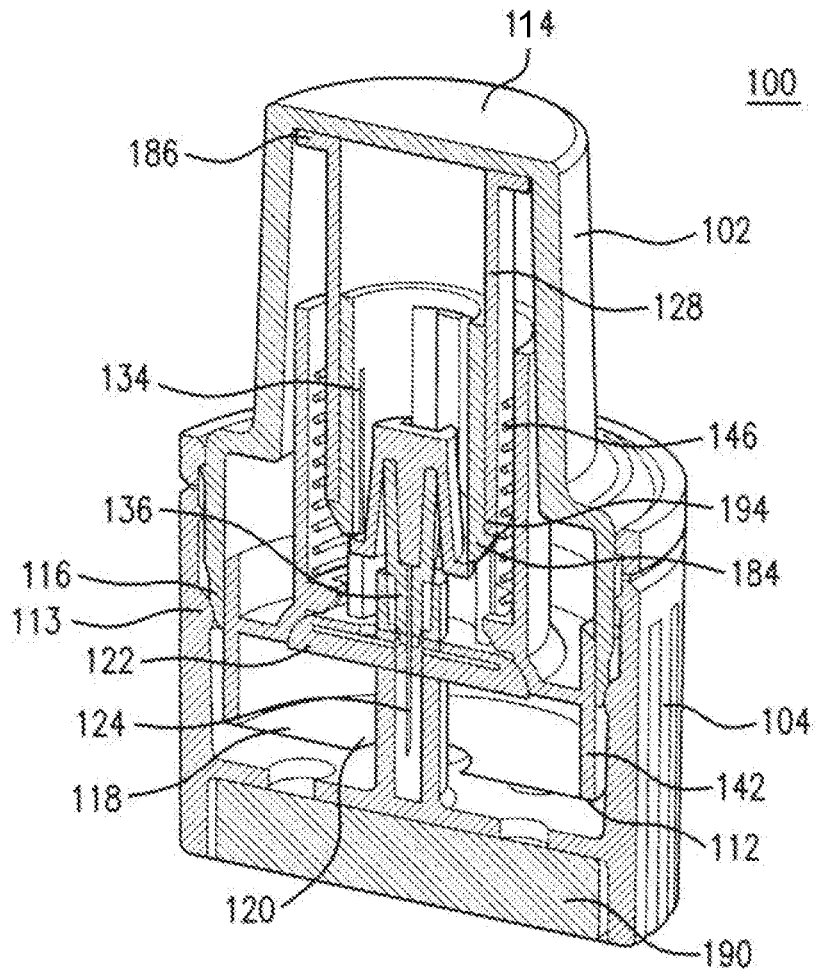

FIG. 10

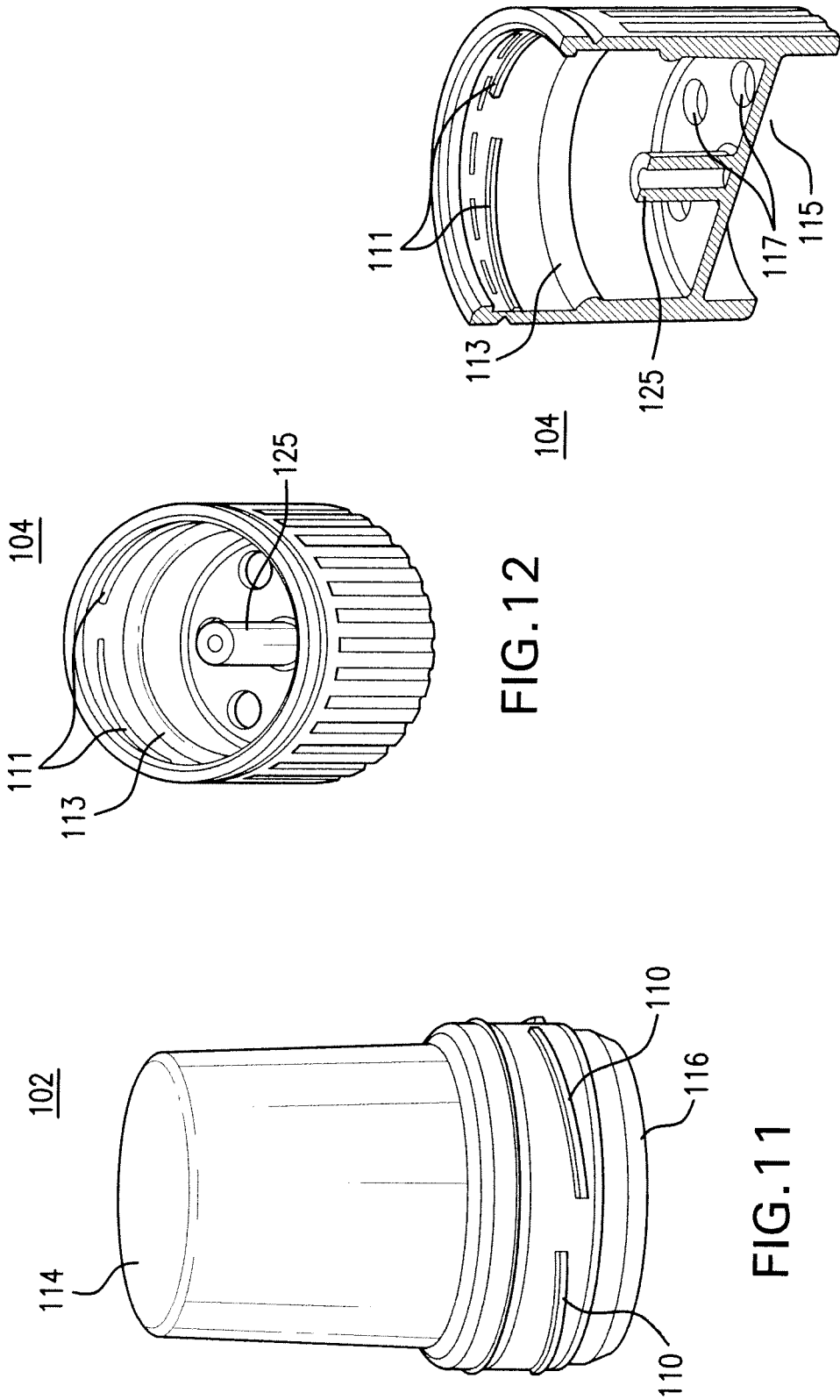

FIG. 12

FIG. 13

FIG. 11

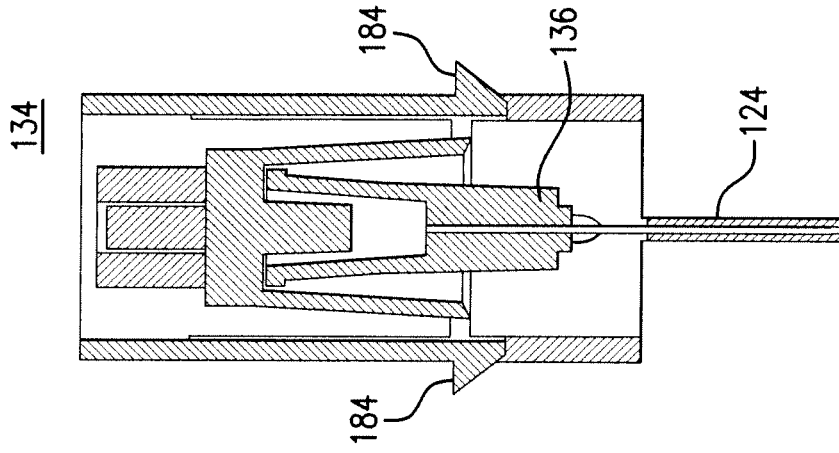

FIG. 14

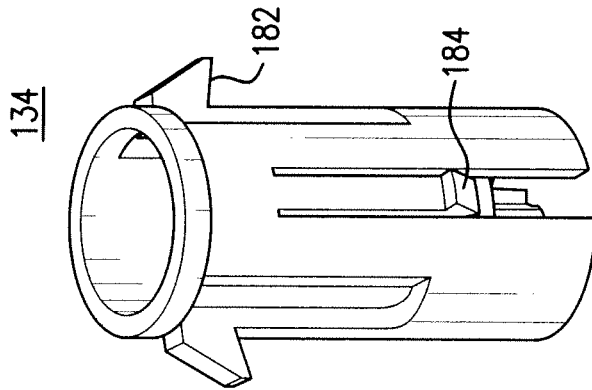

FIG. 15

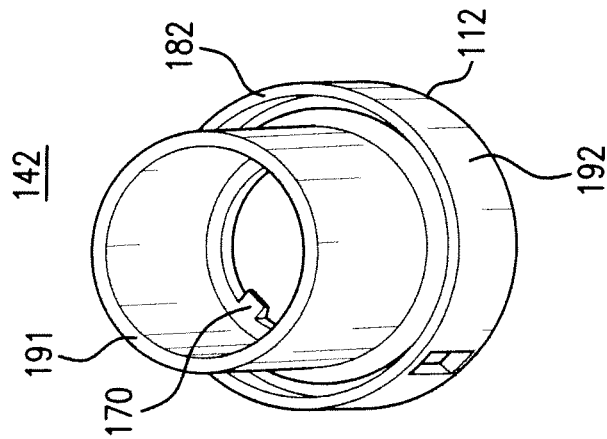

FIG. 16

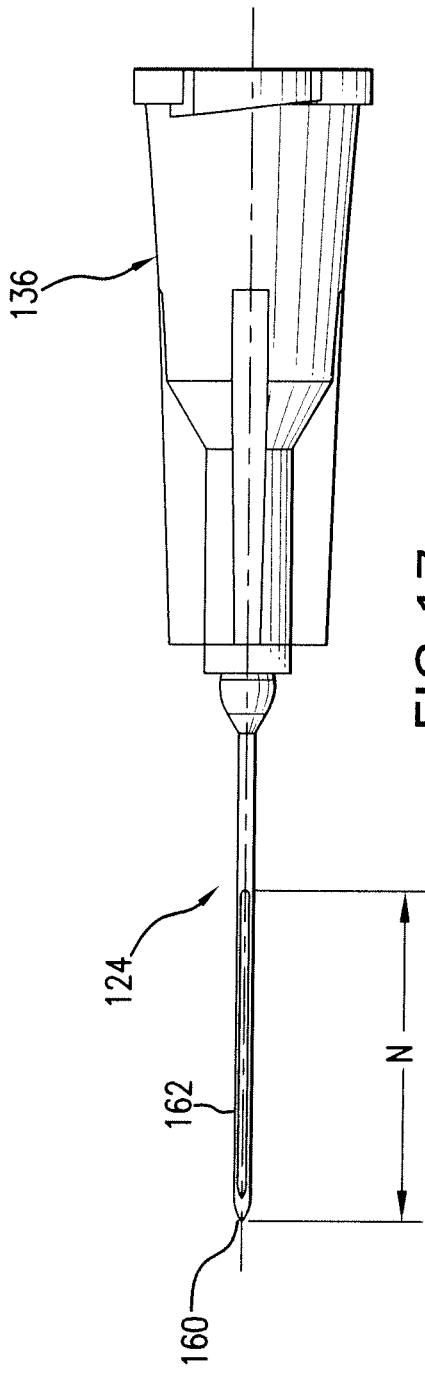

FIG. 17

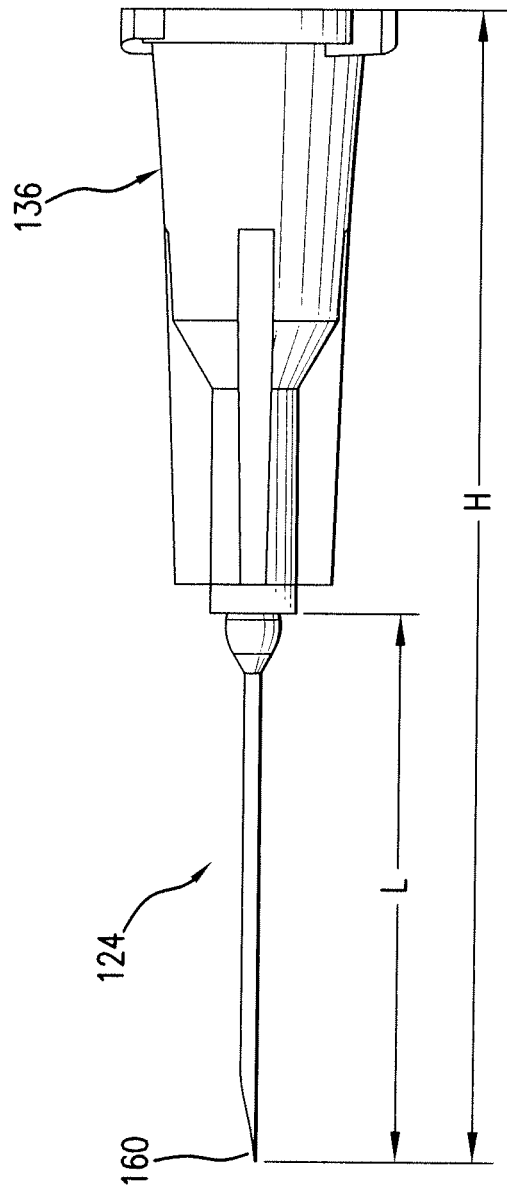

FIG. 18

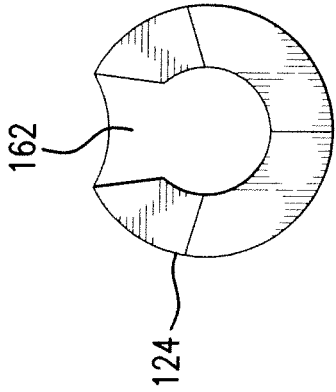

FIG. 19

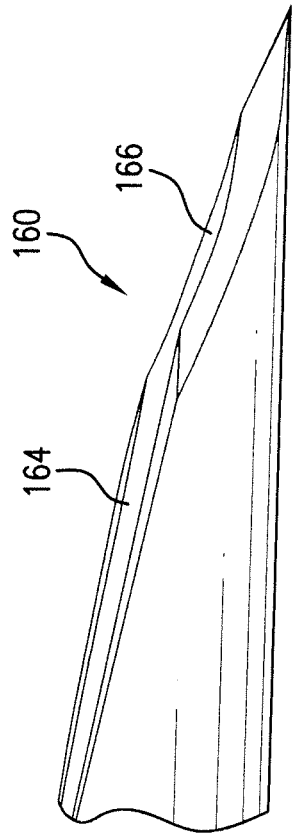

FIG. 20

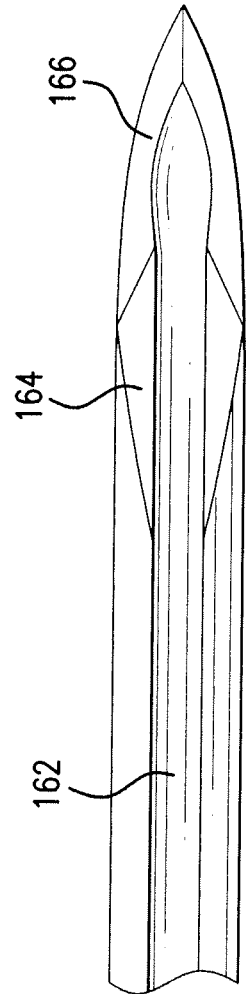

FIG. 21

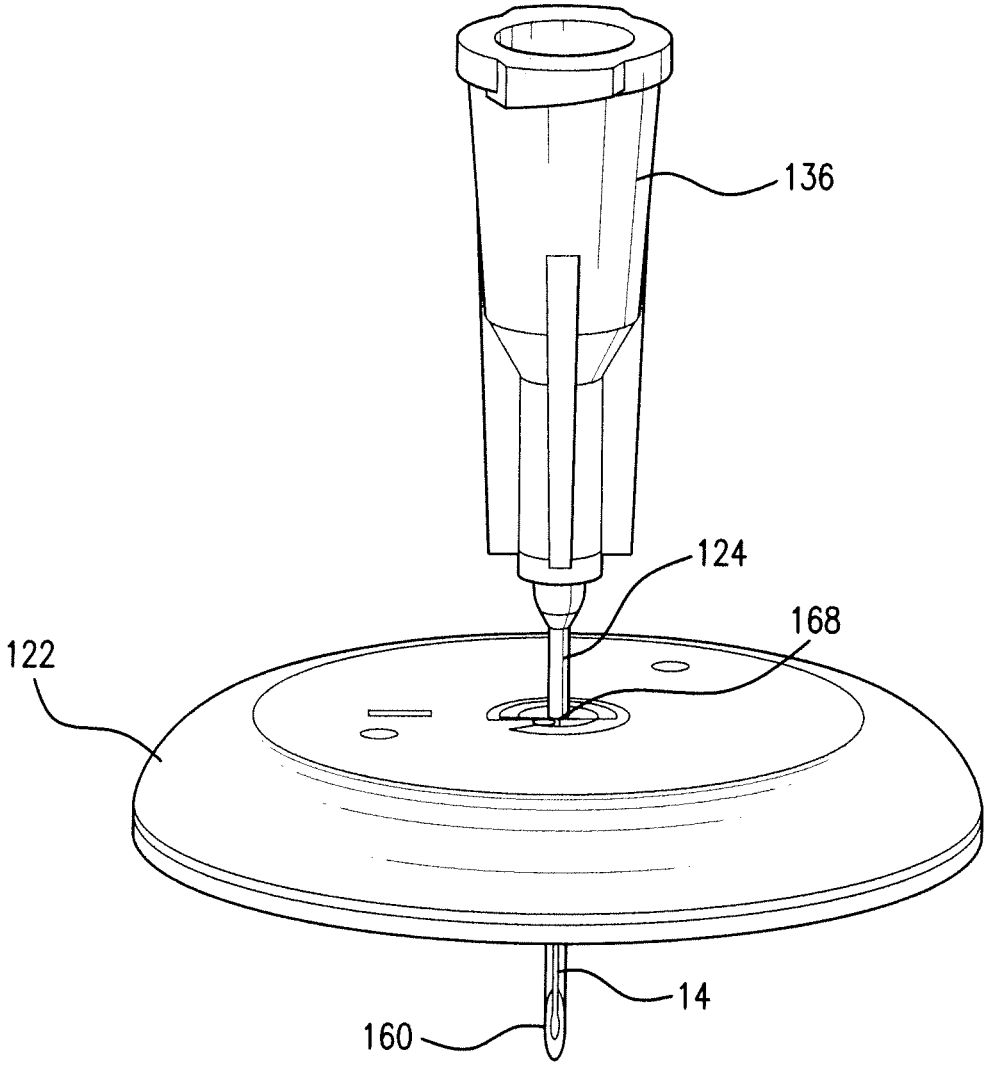

FIG.22

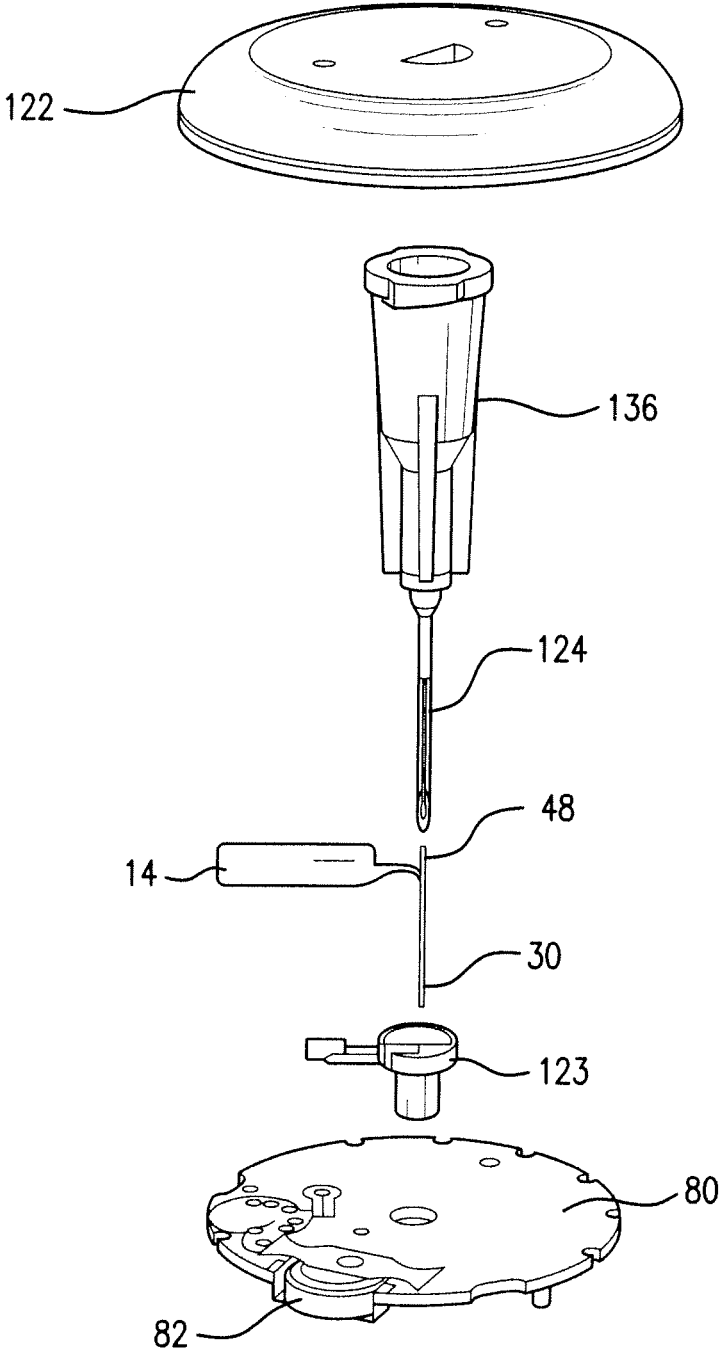

FIG.23



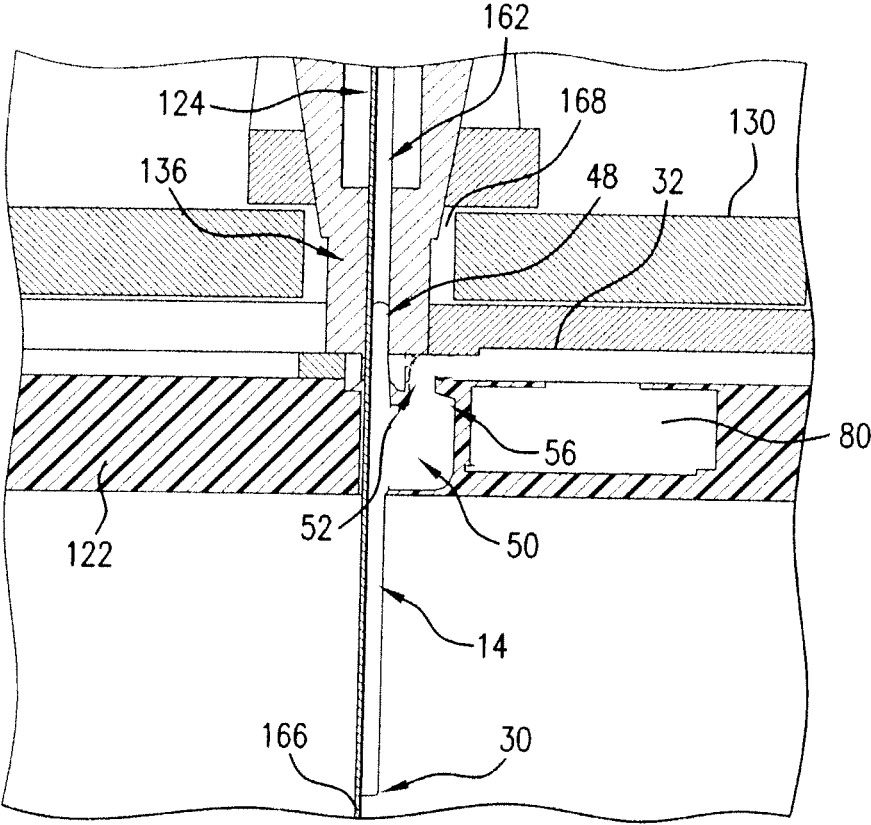

FIG.24

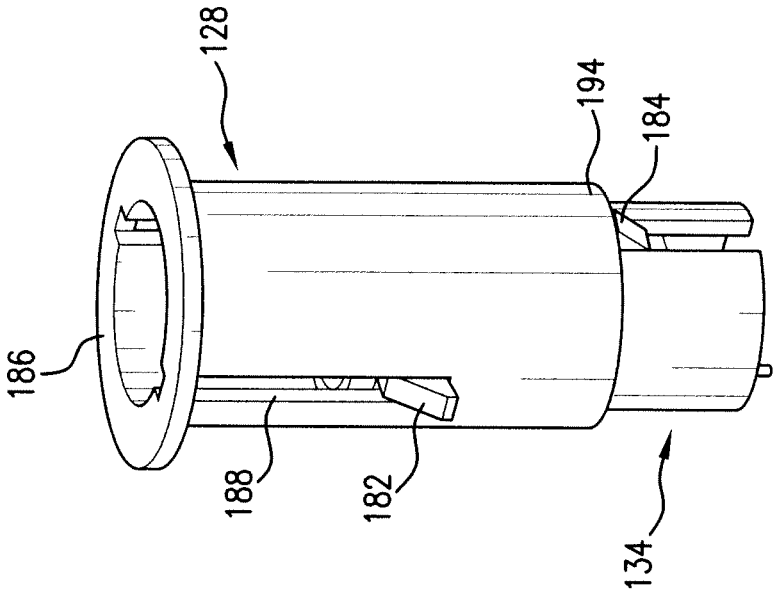

FIG. 26

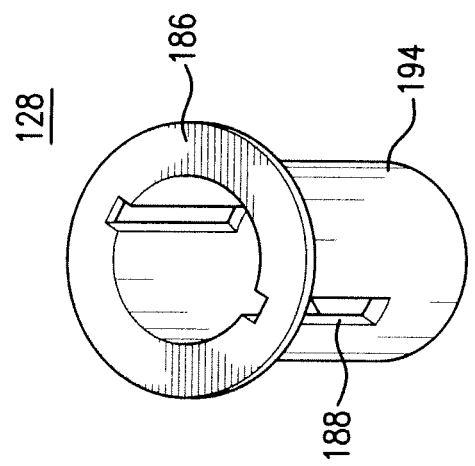

FIG. 25

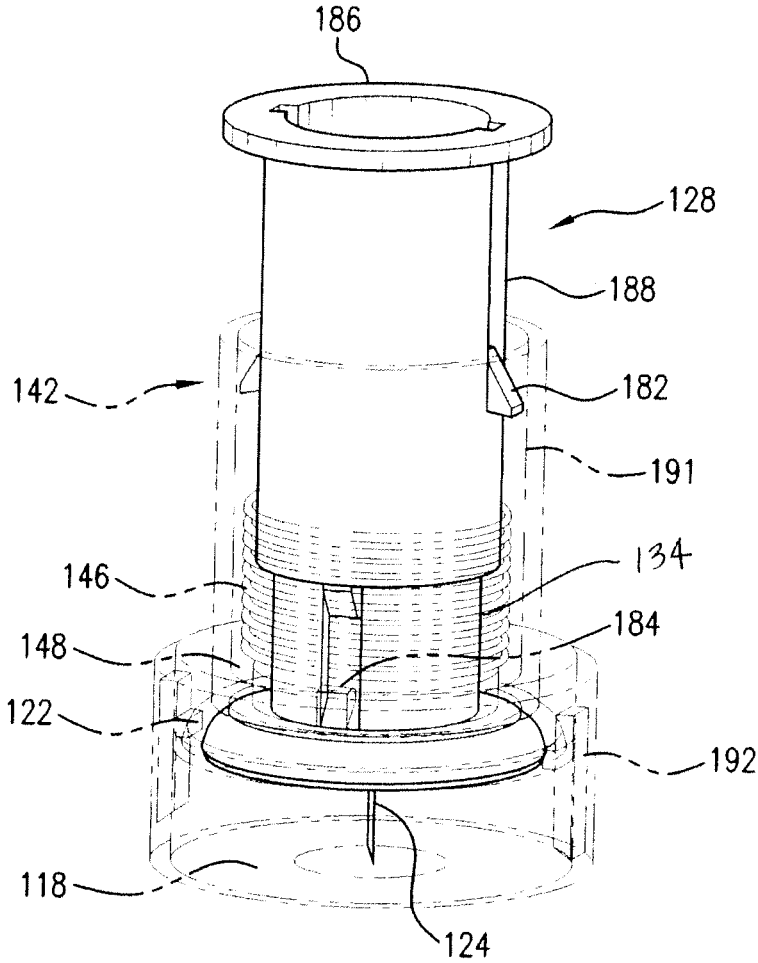

FIG.27

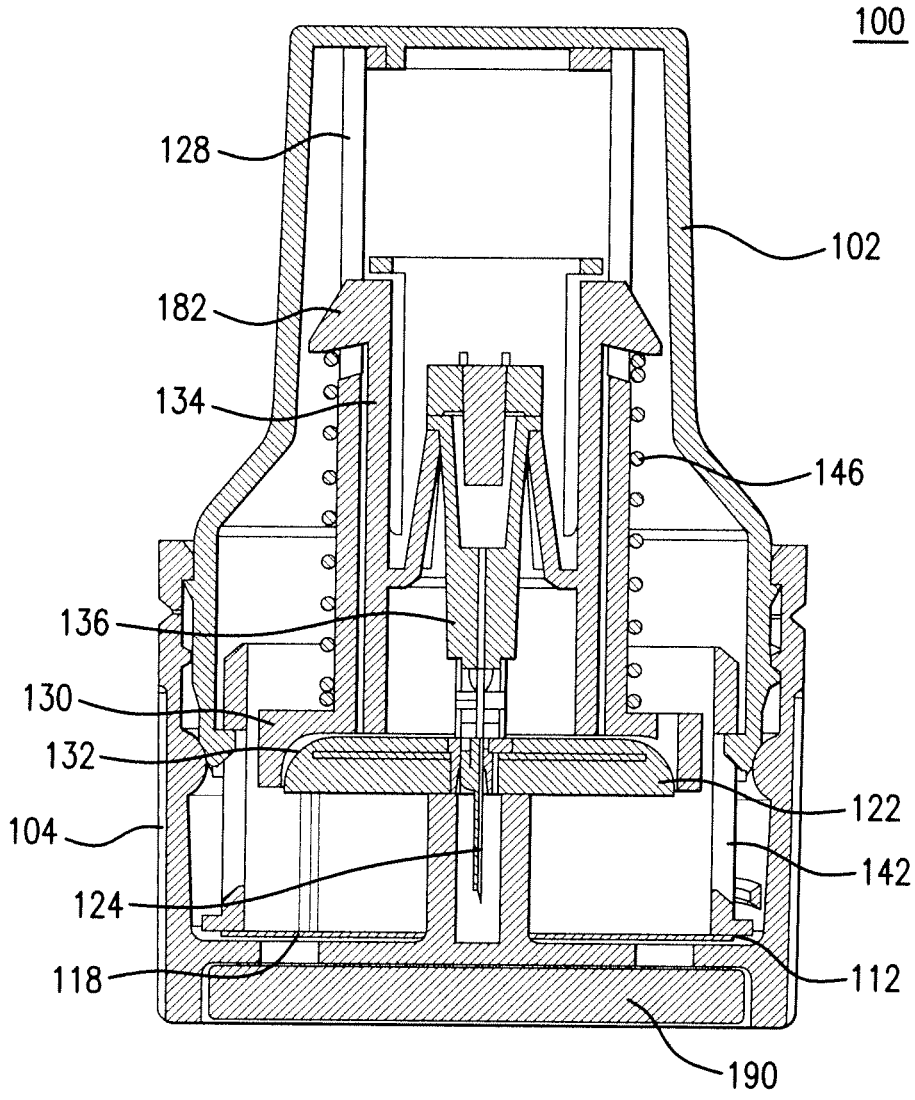

FIG.28

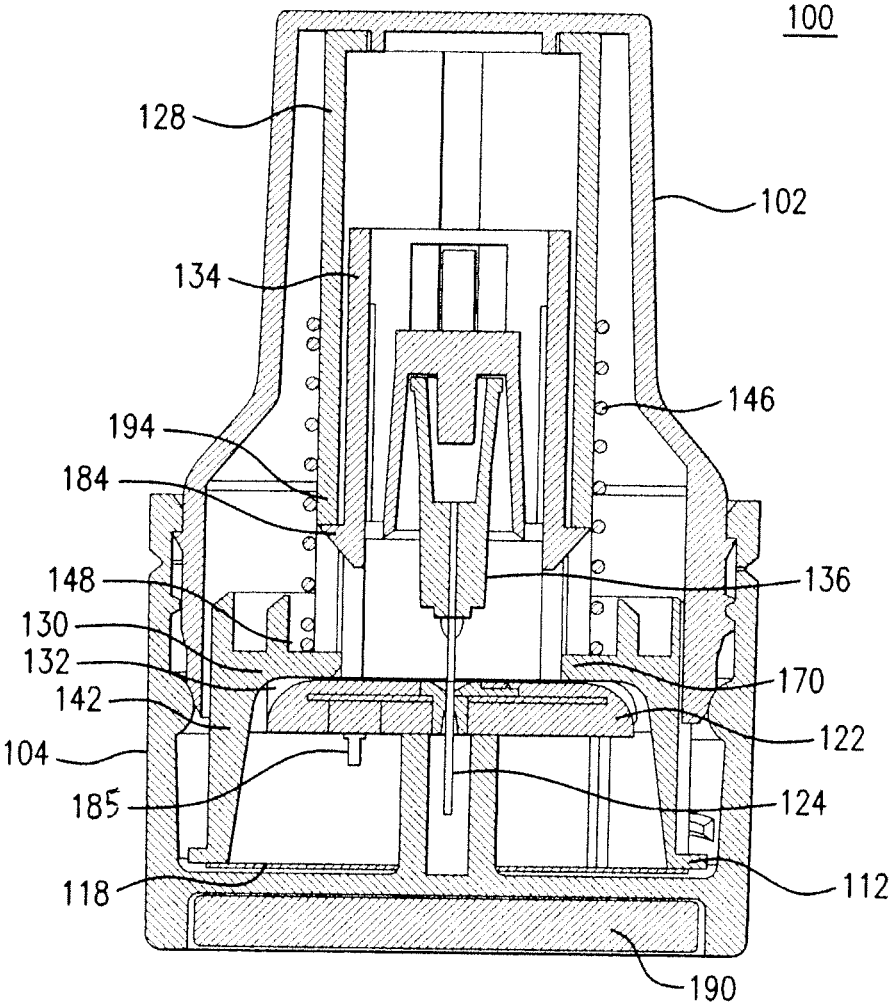

FIG. 29

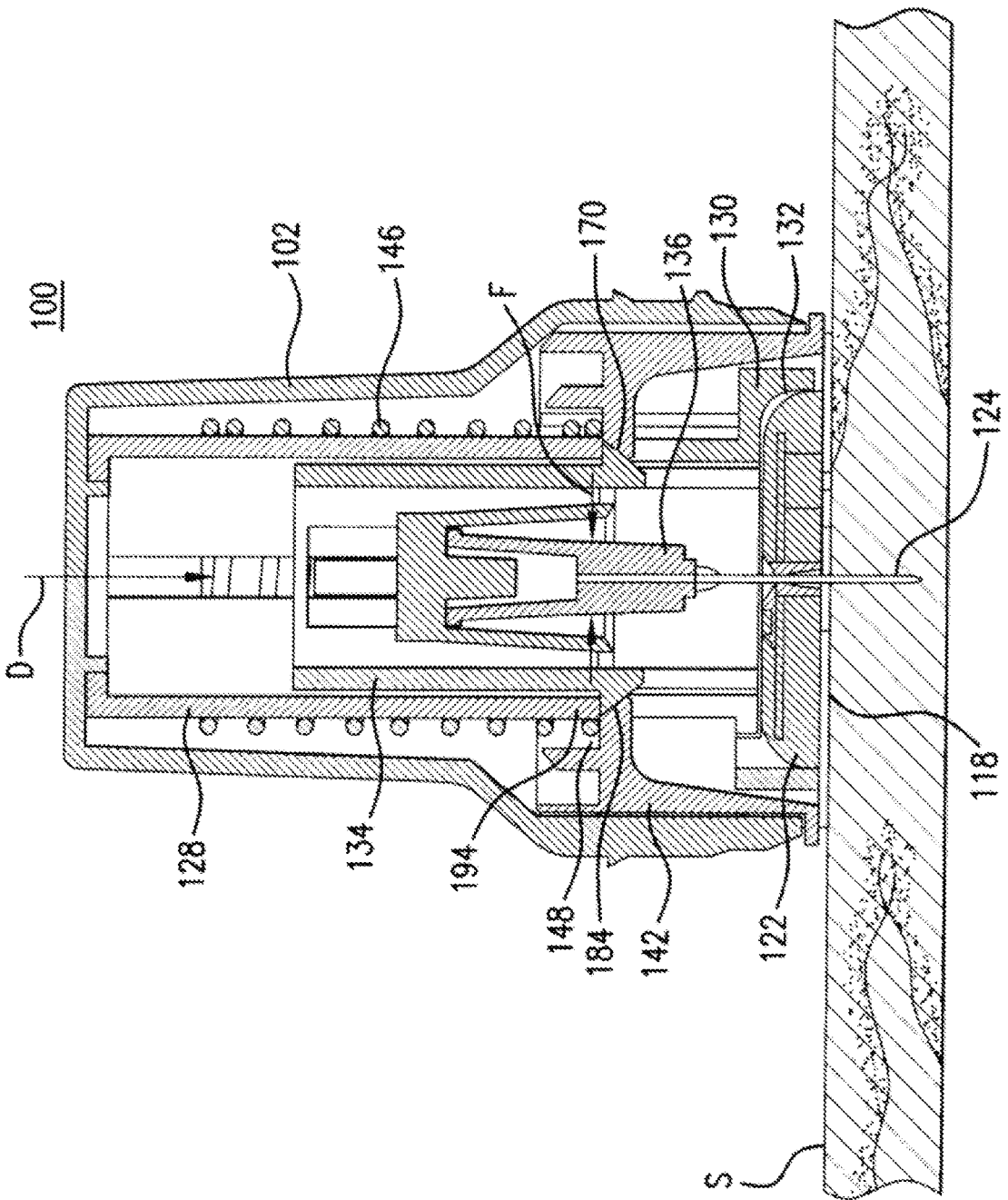

FIG. 30

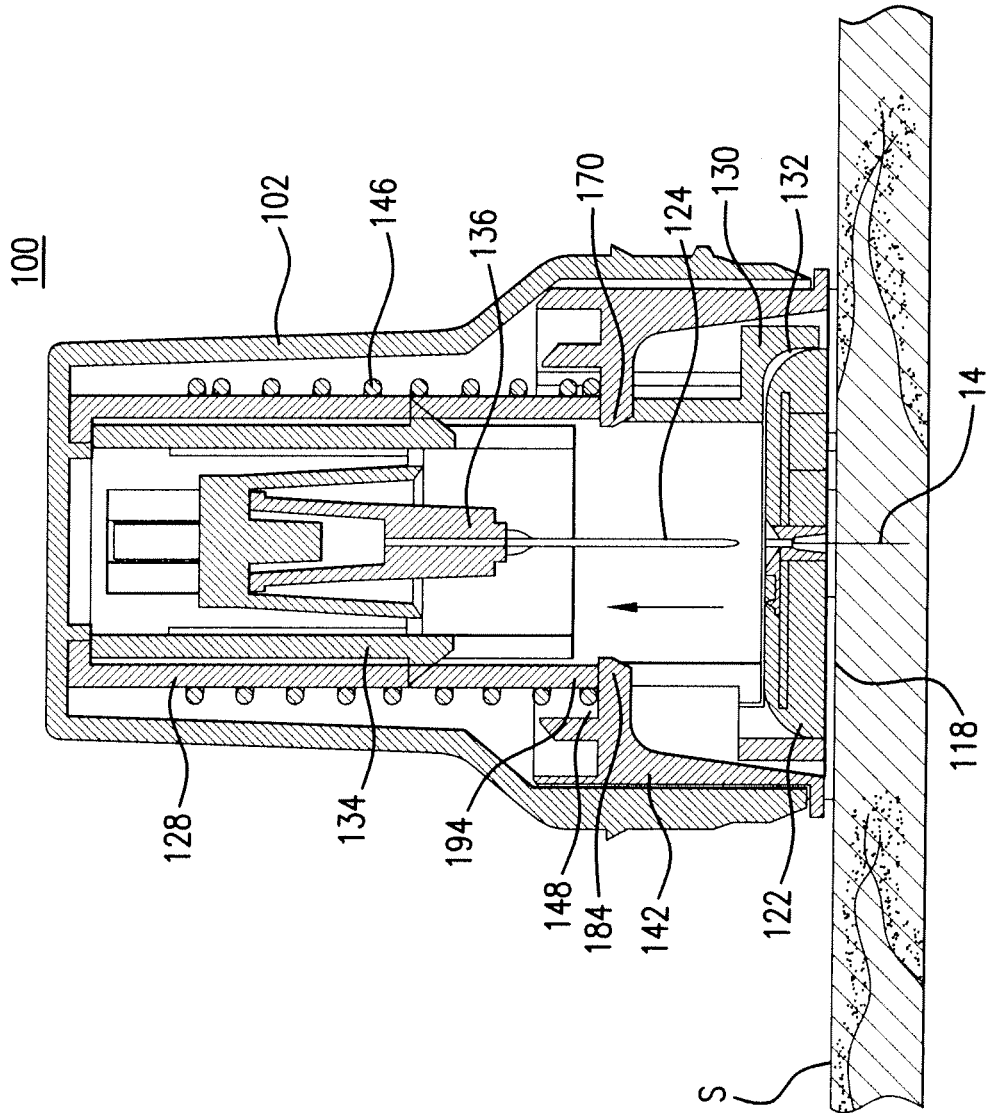

FIG.31

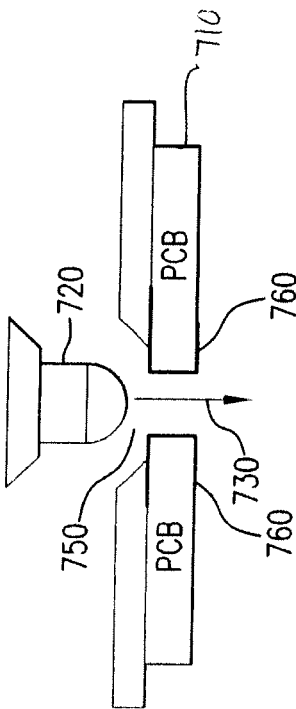

FIG. 32

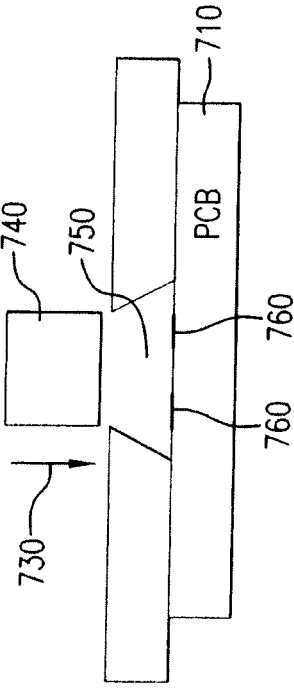

FIG. 33



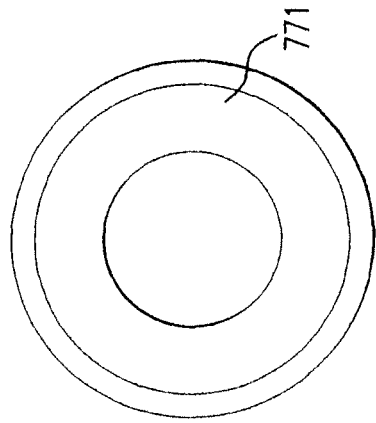

FIG. 34A

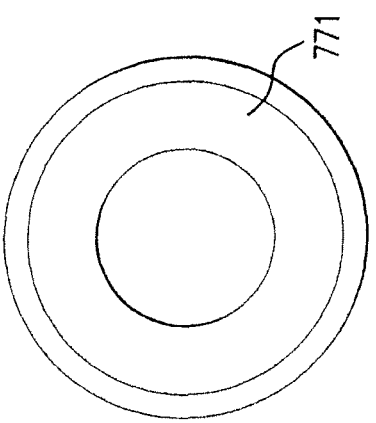

FIG. 35A

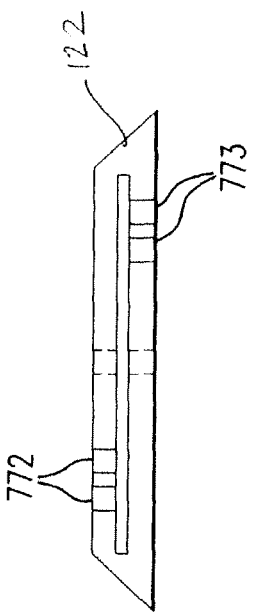

FIG. 34B



FIG. 35B

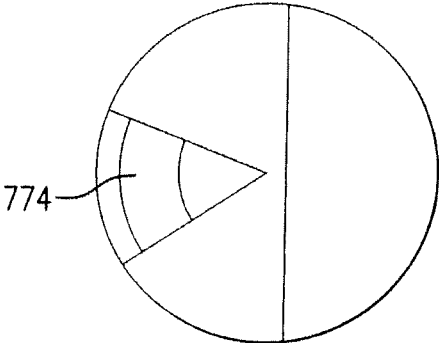

FIG. 36A

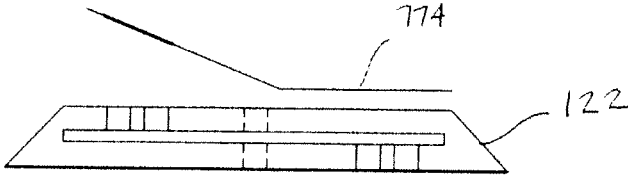

FIG. 36B

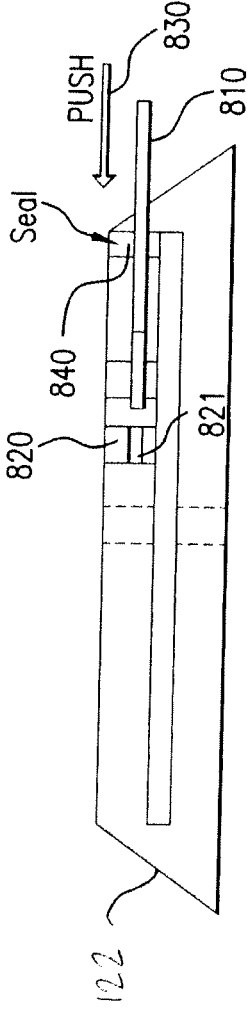

FIG. 37

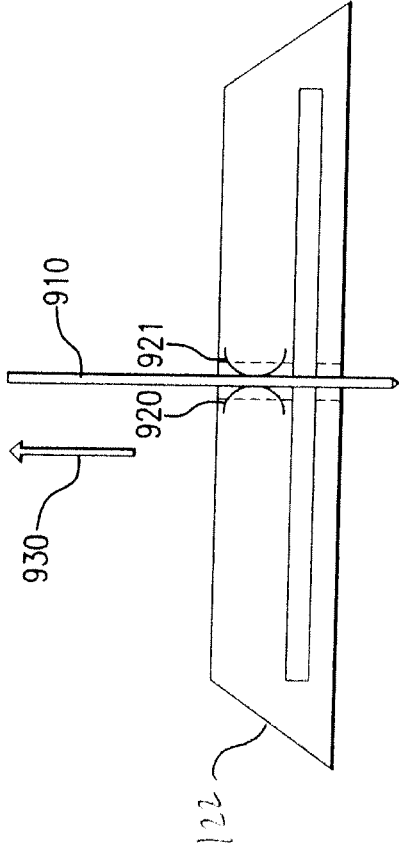

FIG. 38

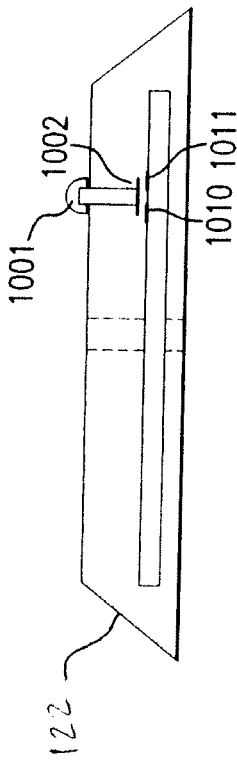

FIG.39

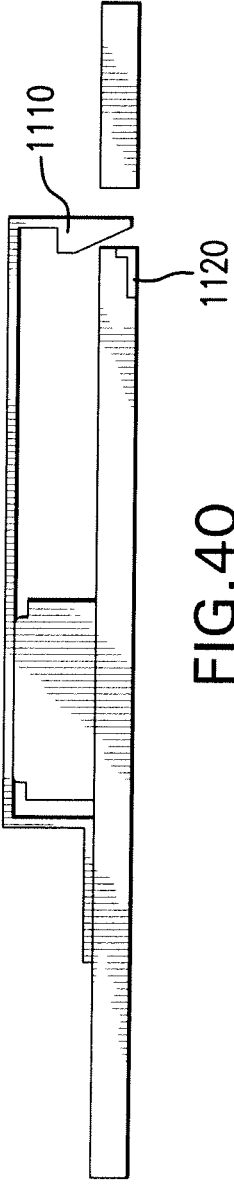

FIG. 40

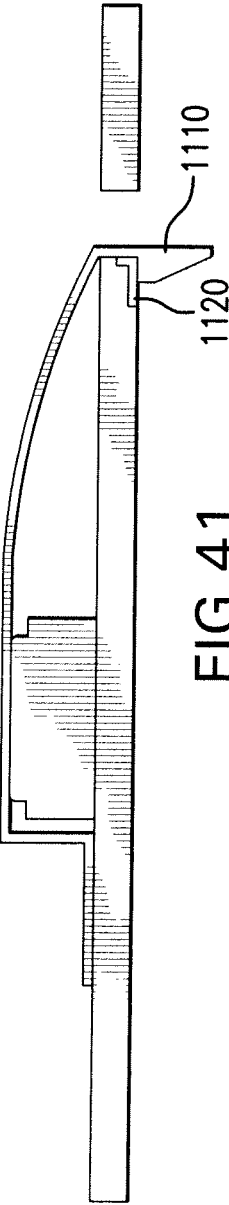

FIG. 41

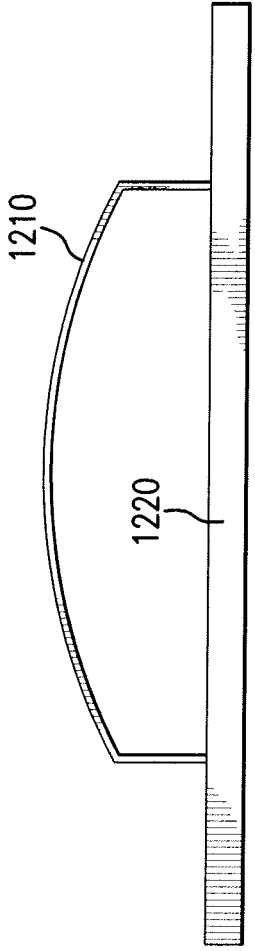

FIG. 42

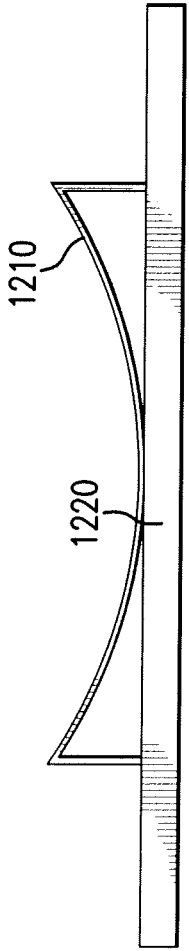

FIG. 43

## ANALYTE SENSOR AND APPARATUS FOR INSERTION OF THE SENSOR

### CROSS-REFERENCE TO RELATED APPLICATIONS

[0001] The present application is a continuation of U.S. patent application Ser. No. 16/736,728, filed Jan. 7, 2020, which is a continuation of U.S. patent application Ser. No. 15/994,129, filed May 31, 2018, which is a continuation of U.S. patent application Ser. No. 15/475,647, filed Mar. 31, 2017, now U.S. Pat. No. 9,993,188, which is a continuation of U.S. patent application Ser. No. 15/192,531, filed Jun. 24, 2016, now U.S. Pat. No. 9,636,068, which is a continuation of U.S. patent application Ser. No. 12/698,129, filed Feb. 1, 2010, now U.S. Pat. No. 9,402,544, which claims priority to U.S. Provisional Application No. 61/149,639, filed Feb. 3, 2009, all of which are incorporated herein by reference in their entireties for all purposes. This application is further related to U.S. patent application Ser. No. 12/698,124, filed Feb. 1, 2010, the disclosure of which is incorporated by reference in its entirety herein for all purposes.

### FIELD OF THE INVENTION

[0002] The present invention relates generally to an inserter device, for example, to insert an analyte sensor and/or an infusion set in an animal such as a human.

### BACKGROUND OF THE INVENTION

[0003] Diabetes Mellitus is an incurable chronic disease in which the body does not produce or properly utilize insulin. Insulin is a hormone produced by the pancreas that regulates blood sugar (glucose). In particular, when blood sugar levels rise, e.g., after a meal, insulin lowers the blood sugar levels by facilitating blood glucose to move from the blood into the body cells. Thus, when the pancreas does not produce sufficient insulin (a condition known as Type 1 Diabetes) or does not properly utilize insulin (a condition known as Type II Diabetes), the blood glucose remains in the blood resulting in hyperglycemia or abnormally high blood sugar levels.

[0004] The vast and uncontrolled fluctuations in blood glucose levels in people suffering from diabetes cause long-term, serious complications. Some of these complications include blindness, kidney failure, and nerve damage. Additionally, it is known that diabetes is a factor in accelerating cardiovascular diseases such as atherosclerosis (hardening of the arteries), leading to stroke, coronary heart disease, and other diseases. Accordingly, one important and universal strategy in managing diabetes is to control blood glucose levels.

[0005] One way to manage blood glucose levels is testing and monitoring blood glucose levels by using conventional in vitro techniques, such as drawing blood samples, applying the blood to a test strip, and determining the blood glucose level using colorimetric, electrochemical, or photometric test meters. Another more recent technique for monitoring blood glucose levels is by using an in vivo glucose monitoring system, that continuously or automatically tests glucose, such as for example, the FreeStyle Navigator® Continuous Glucose Monitoring System, manufactured by Abbott Diabetes Care Inc. Unlike conventional blood glucose meters, continuous analyte monitoring systems employ an insertable or implantable sensor, which detects and monitors blood glucose levels. Prior to each use of a new

sensor, the user self-implants at least a portion of the sensor under his skin. Typically, an inserter assembly is employed to insert the sensor in the body of the user. In this manner, an introducer sharp, while engaged to the sensor, pierces an opening into the skin of the user, releases the sensor and is removed from the body of the user. Accordingly, there exists a need for an easy-to-use, simple, insertion assembly which is reliable, minimizes pain, and is easy to use.

### SUMMARY

[0006] Sensor assemblies that include a medical device, such as an analyte sensor (e.g., a glucose sensor) and/or an infusion device, and a device to position at least a portion of the medical device beneath a skin surface of a user are provided, as well as methods of positioning at least a portion of a medical device such as an analyte sensor (e.g., a glucose sensor) and/or an infusion device beneath a skin surface of a user, and methods of analyte testing.

[0007] Sensor assembly embodiments include a mount adapted to adhere to a skin of a subject; an analyte sensor coupled to the mount, and an insertion sharp having a longitudinal body including a longitudinal opening to receive at least a portion of the sensor body.

[0008] In certain embodiments, the sensor includes a body having a proximal section and a distal section, and the distal section may be longitudinally (or otherwise) aligned with the proximal section. Some sensor embodiments may include an intermediate section. An intermediate section, if present, may be laterally displaced from at least the distal member (or distal section), and a gap may be defined between the laterally displaced intermediate section and a portion of the distal section. In some embodiments, the sensor is integrated with the mount to define an on-body device such as a single unit on-body device. A second gap may be defined in the sensor between the proximal section and the laterally displaced intermediate section. The proximal section of the sensor may have a substantially curved profile.

[0009] In some embodiments, the distal section of the sensor body is received in the longitudinally defined opening of the insertion sharp. A gap may be defined between the distal section and the laterally displaced intermediate section, which allows the distal section, in some embodiments a substantial portion—including the entirety of the distal section, to be received in the longitudinal opening of the insertion needle. The intermediate section and the proximal section may be proximate the distal section received in the insertion needle.

[0010] In some embodiments, the proximal section of the sensor body is in communication with conductive material disposed on the mount. The conductive material disposed on the mount may define a printed circuit board. The proximal section of the sensor may be disposed in a horizontal plane, and the distal section of the sensor body may be disposed in a vertical plane. In some embodiments, the sensor is a transcutaneous sensor. In some embodiments, the sensor is configured for implantation in a soft tissue of a user. In some embodiments, the sensor is a glucose sensor.

[0011] Embodiments include sensor assemblies which include a sensor comprising a portion for operative contact with a fluid of the subject; a mount defining a distal surface adapted for attachment to the skin of a subject and housing a circuit coupled to sensor for performing a function with the sensor; and a switch at least partially disposed in the mount

comprising a member having a first position which protrudes from the distal surface of the mount and a second position which is recessed in the mount, the member configured to activate the circuit when in the second position.

**[0012]** In some embodiments, the member is biased in the first position. The member may comprise an elongated member disposed in an opening in the mount. In some embodiments, the member is moved from the first position to the second position when the mount contacts the skin of the subject. In some embodiments, an adhesive layer is disposed on the skin of the subject, and wherein the member is moved from the first position to the second position when the mount contacts the adhesive layer.

**[0013]** In some embodiments, the switch activates the circuit upon the member reaching the second position. In some embodiments, the switch activates the circuit as long as the member is maintained in the second position. In some embodiments, the sensor is a glucose sensor.

**[0014]** In some embodiments, the circuit applies a potential to the sensor. In some embodiments, the circuit applies a current to the sensor.

**[0015]** In some embodiments, a monitor unit is provided to receive information from the sensor/on-body unit. For example, the system is configured for communication (wired or wirelessly) between the on-body unit and a monitor unit, e.g., using radio frequency communication or other protocol. The communication between the two units may be active or passive. In certain embodiments, the on-body unit circuit includes communication components for wired or wireless transmission of signal relating to analyte level monitored by the sensor to the monitor unit. In certain embodiments, RFID components may be included in the on-body unit and monitor unit to enable RFID communication, in which the on-body unit provides data communication to the monitor unit in response to one or more commands or data communication received from the monitor unit. In some embodiments, the transmitter transmits a signal to the receiver automatically, e.g., continuously or in certain embodiments only periodically, such as according to a predetermined schedule. In some embodiments, in addition to or instead of automatic data communication, the on-body unit may transmit signal to the receiver only in response to a request for the data, e.g., received from the monitor unit or otherwise initiated by the user (e.g., activation of a switch on the receiver or on-body unit to initiate data transfer). In some embodiments, a memory is provided, and the circuit stores a signal relating an analyte level provided by the sensor to the memory. In some embodiments, the sensor is a glucose sensor.

**[0016]** Embodiments include apparatuses for inserting medical devices through the skin of a subject. An insertion apparatus may include a sheath defining a distal surface for placement on the skin of the subject; a handle movable between a proximal position and distal position relative to the sheath; a device support for supporting the medical device and defining an aperture therethrough; a sharp support for supporting a sharp extending through said aperture and coupled to the handle; and driver for biasing the handle and the sharp support towards the proximal position.

**[0017]** In some embodiments, the driver comprises a compression member such as a compression spring. In some embodiments, the handle is at least partially disposed within the sheath. In some embodiments, the handle is at least partially disposed surrounding the sheath. In some embodi-

ments, a bellows portion is provided which is disposed between the handle and the sheath.

**[0018]** In some embodiments, the sharp support is permanently fixed to the handle. In some embodiments, the device support is permanently affixed to the handle.

**[0019]** In some embodiments, a stop portion for retaining the device support in the distal position is included. In some embodiments, the device support is coupled to the sharp support until the device support reaches a distal position.

**[0020]** In some embodiments, the device support is uncoupled from the sharp support when the device support reaches the distal position. In some embodiments, a retention member is provided to couple the sharp support to the sheath when the sharp support is disposed in the proximal position.

**[0021]** In some embodiments, the medical device is an analyte sensor. In some embodiments, the medical device is a glucose sensor. In some embodiments, the medical device is an infusion set.

**[0022]** In certain embodiments, apparatuses for inserting a medical device through the skin of a subject, are provided which include a sheath defining a distal surface for placement on the skin of the subject; a handle movable between a proximal position and distal position; a device support for supporting the medical device and defining an aperture therethrough, the device support coupled to the handle; a sharp support for supporting a sharp extending through said aperture and coupled to the device support; and driver for biasing the sharp support towards the proximal position.

**[0023]** In some embodiments, the driver comprises a compression spring. In some embodiments, the handle is at least partially disposed surrounding the sheath.

**[0024]** In some embodiments, a stop portion for retaining the device support in the distal position is included. In some embodiments, the device support is coupled to the sharp support until the device support reaches a distal position. In some embodiments, the device support is uncoupled from the sharp support when the device support reaches the distal position.

**[0025]** Embodiments of analyte sensors are provided which include a body having a proximal section and a distal section. The distal section may be longitudinally aligned with the proximal section. An intermediate section may be included between the proximal and distal sections, and in some embodiments the intermediate section is laterally displaced from at least the distal member. A gap may be defined between the laterally displaced intermediate section and a portion of the distal section.

**[0026]** In some embodiments, the intermediate section is laterally displaced from at least a portion of the proximal section of the sensor body. A second gap may be defined between the laterally displaced intermediate section and the proximal section of the sensor body. The intermediate section may have a distal end and a proximal end, and further the proximal section may be coupled to the proximal section and the distal section may be coupled to the distal section of the sensor body. In some embodiments, the intermediate section is a longitudinal member. The proximal end may be proximate to the gap defined between the distal member and the intermediate member.

**[0027]** In some embodiments, the proximal end is received within a needle seat to create an anchor region to allow the sensor body to slide into an opening defined in the insertion sharp but prevent the sensor body from inadvertently slip-



ping out of the insertion needle. In some embodiments, a width of the distal section of the sensor body is sized to fit within the opening of the insertion sharp having a diameter less than about 22 to about 24 gauge.

**[0028]** In some embodiments, the intermediate member includes a plane-altering portion. The plane-altering portion allows the proximal section of the sensor body to be in a plane different than the distal section of the sensor body. In some embodiments, the proximal section and the distal section are in planes substantially perpendicular to each other, e.g., the area may define an angle of about 120° to about 60°, e.g., about 90 degrees.

**[0029]** In some embodiments, the proximal section has a curved portion.

**[0030]** In some embodiments, the sensor body includes conductive material disposed in or on a surface thereto to define one or more electrodes. The sensor body may include conductive material defining traces disposed in or on a surface of the sensor body. The traces are in communication with the one or more electrodes. The traces may be disposed in or on at least surface of the proximal section of the sensor body. The one or more electrodes may be disposed on the distal section of the sensor body. At least one of the traces or electrodes may include a metal or carbon material such as gold, platinum, titanium, carbon. At least one of the traces or electrodes may be formed by ablation of material. The ablation may include laser ablation.

**[0031]** In some embodiments, the sensor comprises a sensing layer. The sensing layer may comprise an enzyme. The sensing layer may comprise an electron transfer agent. The electron transfer agent may be a redox mediator. In some embodiments, the electron transfer agent includes osmium transition metal complexes and one or more ligands. The electron transfer agent may be configured to transfer electrons directly between the analyte and the working electrode. The electron transfer agent may be configured to transfer electrons indirectly between the analyte and the working electrode.

**[0032]** In some embodiments, the sensing layer comprises a redox polymer. The redox polymer may include osmium. The sensing layer may include a catalyst. The catalyst may include an enzyme. The catalyst may act as an electron transfer agent. In some embodiments, the enzyme includes glucose oxidase. In some embodiments, the enzyme includes glucose dehydrogenase.

**[0033]** In some embodiments, the sensing layer is configured such that the reaction of glucose in the presence of an enzyme forms hydrogen peroxide, and glucose level may be correlated to the level of hydrogen peroxide. In some embodiments, the sensor is a subcutaneous sensor.

**[0034]** These and other features, objects and advantages of the disclosed subject matter will become apparent to those persons skilled in the art upon reading the detailed description as more fully described below.

#### BRIEF DESCRIPTION OF THE DRAWINGS

**[0035]** A detailed description of various aspects, features, and embodiments of the subject matter described herein is provided with reference to the accompanying drawings, which are briefly described below. The drawings are illustrative and are not necessarily drawn to scale, with some components and features being exaggerated for clarity. The drawings illustrate various aspects and features of the pres-

ent subject matter and may illustrate one or more embodiment(s) or example(s) of the present subject matter in whole or in part.

**[0036]** FIG. 1 is a schematic view of the system in accordance with one embodiment of the disclosed subject matter;

**[0037]** FIG. 2 is a view, in partial cross section, of an electrochemical sensor in accordance with one embodiment of the disclosed subject matter;

**[0038]** FIG. 3 is a view of an electrochemical sensor in accordance with another embodiment of the disclosed subject matter;

**[0039]** FIG. 4 is a view of the electrochemical sensor of FIG. 3 in a folded configuration in accordance with the disclosed subject matter;

**[0040]** FIG. 5 is a view of an electrochemical sensor in accordance with a further embodiment of the disclosed subject matter;

**[0041]** FIG. 6 is a view of the electrochemical sensor of FIG. 5 in a folded configuration in accordance with the disclosed subject matter;

**[0042]** FIG. 7 is a perspective view of an on-body unit in accordance with one embodiment of the disclosed subject matter;

**[0043]** FIG. 8 is a perspective view in partial cross-section of an on-body unit of FIG. 7 in accordance with the disclosed subject matter;

**[0044]** FIG. 9 is a schematic view of the system in accordance with one embodiment of the disclosed subject matter;

**[0045]** FIG. 10 is a sectional, perspective view of another embodiment of an inserter in accordance with the disclosed subject matter;

**[0046]** FIGS. 11-12 are perspective views of components of the inserter of FIG. 10 in accordance with the disclosed subject matter;

**[0047]** FIG. 13 is a sectional view of a component of the inserter of FIG. 10 in accordance with the disclosed subject matter;

**[0048]** FIGS. 14-15 are a perspective views of components of the inserter of FIG. 10 in accordance with the disclosed subject matter;

**[0049]** FIG. 16 is a sectional view of the component of FIG. 14 in accordance with the disclosed subject matter;

**[0050]** FIGS. 17-18 are schematic views of a needle hub in accordance with one embodiment of the disclosed subject matter;

**[0051]** FIG. 19 is a distal end view of a sharp in accordance with one embodiment of the disclosed subject matter;

**[0052]** FIG. 20 is a side view of a sharp in accordance with one embodiment of the disclosed subject matter;

**[0053]** FIG. 21 is a side view of a sharp in accordance with one embodiment of the disclosed subject matter;

**[0054]** FIG. 22 is a perspective view with parts of an inserter in accordance with one embodiment of the disclosed subject matter;

**[0055]** FIG. 23 is a perspective view with parts separated of an inserter in accordance with one embodiment of the disclosed subject matter;

**[0056]** FIG. 24 is an enlarged sectional view with parts separated of an inserter in accordance with one embodiment of the disclosed subject matter;

[0057] FIGS. 25-27 are perspective views of components of the inserter of FIG. 10 in accordance with the disclosed subject matter;

[0058] FIGS. 28-31 are sectional views of the inserter of FIG. 10 in accordance with the disclosed subject matter;

[0059] FIGS. 32-33 illustrate a power supply switch mechanism including conductive plug of the on-body integrated sensor and sensor electronics assembly in accordance with embodiments of the disclosed subject matter;

[0060] FIGS. 34A-36B illustrate a power supply switch mechanism including conductive pads on the on-body integrated sensor and sensor electronics assembly in accordance with embodiments of the disclosed subject matter;

[0061] FIG. 37 illustrates a power supply switch mechanism including an internal switch with a push rod activation of the on-body integrated sensor and sensor electronics assembly in accordance with embodiments of the disclosed subject matter;

[0062] FIG. 38 illustrates power supply switch mechanism including introducer retraction trigger activation of the on-body integrated sensor and sensor electronics assembly in accordance with embodiments of the disclosed subject matter;

[0063] FIG. 39 illustrates a power supply switch mechanism with a contact switch of the on-body integrated sensor and sensor electronics assembly in accordance with embodiments of the disclosed subject matter;

[0064] FIGS. 40-41 illustrate a power supply switch mechanism with a battery contact locking mechanism of the on-body integrated sensor and sensor electronics assembly in accordance with embodiments of the disclosed subject matter;

[0065] FIGS. 42-43 illustrate a power supply switch mechanism with a bi-modal dome switch of the on-body integrated sensor and sensor electronics assembly in accordance with embodiments of the disclosed subject matter.

#### DETAILED DESCRIPTION OF THE EMBODIMENTS

[0066] A detailed description of the disclosure is provided herein. It should be understood, in connection with the following description, that the subject matter is not limited to particular embodiments described, as the particular embodiments of the subject matter may of course vary. It is also to be understood that the terminology used herein is for the purpose of describing particular embodiments only, and is not intended to be limiting, since the scope of the disclosed subject matter will be limited only by the appended claims.

[0067] Where a range of values is provided, it is understood that each intervening value between the upper and lower limit of that range and any other stated or intervening value in that stated range, is encompassed within the disclosed subject matter. Every range stated is also intended to specifically disclose each and every "subrange" of the stated range. That is, each and every range smaller than the outside range specified by the outside upper and outside lower limits given for a range, whose upper and lower limits are within the range from said outside lower limit to said outside upper limit (unless the context clearly dictates otherwise), is also to be understood as encompassed within the disclosed subject matter, subject to any specifically excluded range or limit within the stated range. Where a range is stated by specifying one or both of an upper and lower limit, ranges

excluding either or both of those stated limits, or including one or both of them, are also encompassed within the disclosed subject matter, regardless of whether or not words such as "from", "to", "through", or "including" are or are not used in describing the range.

[0068] Unless defined otherwise, all technical and scientific terms used herein have the same meaning as commonly understood by one of ordinary skill in the art to which this disclosed subject matter belongs. Although any methods and materials similar or equivalent to those described herein can also be used in the practice or testing of the present disclosed subject matter, this disclosure may specifically mention certain exemplary methods and materials.

[0069] All publications mentioned in this disclosure are, unless otherwise specified, incorporated herein by reference for all purposes, including without limitation to disclose and describe the methods and/or materials in connection with which the publications are cited.

[0070] The publications discussed herein are provided solely for their disclosure prior to the filing date of the present application. Nothing herein is to be construed as an admission that the present disclosed subject matter is not entitled to antedate such publication by virtue of prior invention. Further, the dates of publication provided may be different from the actual publication dates, which may need to be independently confirmed.

[0071] As used herein and in the appended claims, the singular forms "a", "an", and "the" include plural referents unless the context clearly dictates otherwise.

[0072] Nothing contained in the Abstract or the Summary should be understood as limiting the scope of the disclosure. The Abstract and the Summary are provided for bibliographic and convenience purposes and due to their formats and purposes should not be considered comprehensive.

[0073] As will be apparent to those of skill in the art upon reading this disclosure, each of the individual embodiments described and illustrated herein has discrete components and features which may be readily separated from or combined with the features of any of the other several embodiments without departing from the scope or spirit of the present disclosed subject matter. Any recited method can be carried out in the order of events recited, or in any other order which is logically possible. Reference to a singular item, includes the possibility that there are plural of the same item present. When two or more items (for example, elements or processes) are referenced by an alternative "or", this indicates that either could be present separately or any combination of them could be present together except where the presence of one necessarily excludes the other or others.

#### System Overview

[0074] Certain classes of analyte monitors are provided in small, lightweight, battery-powered and electronically-controlled systems. Such a system may be configured to detect signals indicative of in vivo analyte levels using an electrochemical sensor, and collect such signals, with or without processing the signal. In some embodiments, the portion of the system that performs this initial processing may be configured to provide the raw or initially processed data to another unit for further collection and/or processing. Such provision of data may be effected, for example, via a wired connection, such as an electrical, or via a wireless connection, such as an IR or RF connection.

**[0075]** Certain analyte monitoring systems for in vivo measurement employ a sensor that measures analyte levels in interstitial fluids under the surface of the subject's skin. These may be inserted partially through the skin ("transcutaneous") or entirely under the skin ("subcutaneous"). A sensor in such a system may operate as an electrochemical cell. Such a sensor may use any of a variety of electrode configurations, such as a three-electrode configuration (e.g., with "working", "reference" and "counter" electrodes), driven by a controlled potential (potentiostat) analog circuit, a two-electrode system configuration (e.g., with only working and counter electrodes), which may be self-biasing and/or self-powered, and/or other configurations. In some embodiments, the sensor may be positioned within a blood vessel.

**[0076]** In certain systems, the analyte sensor is in communication with a sensor control unit. As used in this disclosure, an on-body unit sometimes refers to such a combination of an analyte sensor with such a sensor control unit.

**[0077]** Certain embodiments are modular. The on-body unit may be separately provided as a physically distinct assembly, and configured to provide the analyte levels detected by the sensor over a communication link to a monitor unit, referred to in this disclosure as a "receiver unit" or "receiver device", or in some contexts, depending on the usage, as a "display unit," "handheld unit," or "meter". The monitor unit, in some embodiments, may include, e.g., a mobile telephone device, a personal digital assistant, other consumer electronic device such as MP3 device, camera, radio, etc., or other communication-enabled data processing device.

**[0078]** The monitor unit may perform data processing and/or analysis, etc. on the received analyte data to generate information pertaining to the monitored analyte levels. The monitor unit may incorporate a display screen, which can be used, for example, to display measured analyte levels, and/or audio component such as a speaker to audibly provide information to a user, and/or a vibration device to provide tactile feedback to a user. It is also useful for a user of an analyte monitor to be able to see trend indications (including the magnitude and direction of any ongoing trend), and such data may be displayed as well, either numerically, or by a visual indicator, such as an arrow that may vary in visual attributes, such as size, shape, color, animation, or direction. The receiver device may further incorporate an in vitro analyte test strip port and related electronics in order to be able to make discrete (e.g., blood glucose) measurements.

**[0079]** The modularity of these systems may vary. In some embodiments the sensor is attachable and detachable from the sensor control unit (and the on-body unit may be reusable), while in other embodiments, the sensor and sensor control unit may be provided as an integrated, un-detachable package, which may be disposable after use.

**[0080]** FIG. 1 shows one embodiment of an analyte measurement system 10. In such a system, a data processing unit or sensor control unit 12 may interact with an analyte sensor 14 to obtain signals representative of analyte levels. Sensor control unit 12 may further include communications circuit with associated electronics (not shown). In some embodiments, the sensor control unit 12 and sensor are constructed to be maintained "on the body" of the subject for a period of time that may include hours, days, weeks, or a month or

more. Accordingly, the sensor control unit 12 and sensor 14 may be referred to collectively herein as an on-body unit 16. A receiver unit or monitor unit 18 may also be provided. In the embodiment shown, sensor control unit 12 and monitor unit 18 communicate via connection 20 (in this embodiment, a wireless RF connection). Communication may occur, e.g., via RF communication, infrared communication, Bluetooth® communication, Zigbee® communication, 802.1x communication, or WiFi communication, etc. In some embodiments, the communication may include an RF frequency of 433 MHz, 13.56 MHz, or the like. In some embodiments, a secondary monitor unit 22 may be provided. A data processing terminal 24 is useful for providing further processing or review of analyte data.

**[0081]** In certain embodiments, system 10 may be a continuous analyte monitor (e.g., a continuous glucose monitoring system or CGM), and accordingly operate in a mode in which the communications via connection 20 has sufficient range to support a flow of data from on-body unit 16 to monitor unit 18. In some embodiments, the data flow in a CGM system is automatically provided by the on-body unit 16 to the monitor unit 18. For example, no user intervention may be required for the on-body unit 16 to send the data to the monitor unit 18. In some embodiments, the on-body unit 16 provides the signal relating to analyte level to the receiving unit 18 on a periodic basis. For example, the signal may be provided, e.g., automatically sent, on a fixed schedule, e.g., once every 250 ms, once a second, once a minute, etc. In some embodiments, the signal is provided to the monitor unit 18 upon the occurrence of an event, e.g., a hyperglycemic event or a hypoglycemic event, etc. In some embodiments, data processing unit 12 may further include local memory in which it may record, "logged data" or buffered data collected over a period of time and provide the some or all of the accumulated data to monitor unit 18 from time-to-time. Or, a separate data logging unit may be provided to acquire periodically transmitted data from a transmitter device. Data transmission in a CGM system may be one-way communication, e.g., the on-body unit 16 provides data to the monitor unit 18 without receiving signals from the monitor unit 18. In some embodiments, two-way communication is provided between the on-body unit 16 and the monitor unit 18.

**[0082]** In some embodiments, a signal is provided to the monitor unit 18 "on demand." According to such embodiments, the monitor unit 18 requests a signal from the on-body unit 16, or the on-body unit 16 may be activated to send signal upon activation to do so. Accordingly, one or both of the on-body unit 16 and monitor unit 18 may include a switch activatable by a user or activated upon some other action or event, the activation of which causes analyte-related signal to be transferred from the on-body unit 16 to the monitor unit 18. For example, the monitor unit 18 is placed in close proximity with a transmitter device and initiates a data transfer, either over a wired connection, or wirelessly by various means, including, for example various RF-carried encodings and protocols and IR links.

**[0083]** In some embodiments, the signal relating to analyte level is instantaneously generated by the analyte sensor 14 upon receipt of the request, and transmitted to the monitor unit 18 as requested, and/or the signal relating to analyte level is periodically obtained, e.g., once every 250 ms, once a second, once a minute, etc. Upon receipt of the "on demand" request at the on-body unit 16, an analyte signal is

provided to the monitor unit. In some cases, the signal provided to the monitor unit **18** is or at least includes the most recent analyte signal(s).

**[0084]** In further embodiments, additional data is provided to the monitor unit **18** “on demand.” For example, analyte trend data may be provided. Such trend data may include two or more analyte data points to indicate that analyte levels are rising, falling, or stable. Analyte trend data may include data from longer periods of time, such as, e.g., several minutes, several hours, several days, or several weeks.

**[0085]** Further details regarding on demand systems are disclosed in U.S. Pat. No. 7,620,438, U.S. Patent Publication Nos. 2009/0054749 A1, published Feb. 26, 2009; 2007/0149873 A1, published Jun. 28, 2007, now U.S. Pat. No. 9,014,773; 2008/0064937 A1, published Mar. 13, 2008; 2008/0071157 A1, published Mar. 20, 2008; 2008/0071158 A1, published Mar. 20, 2008; 2009/0281406 A1, published Nov. 12, 2009; 2008/0058625 A1, published Mar. 6, 2008, now U.S. Pat. No. 7,920,907; 2009/0294277 A1, published Dec. 3, 2009; 2008/0319295 A1, published Dec. 25, 2008, now U.S. Pat. No. 8,597,188; 2008/0319296 A1, published Dec. 25, 2008, now U.S. Pat. No. 8,617,069; 2009/0257911 A1, published Oct. 15, 2009, now U.S. Pat. No. 8,252,229; 2008/0179187 A1, published Jul. 31, 2008, now U.S. Pat. No. 8,808,515; 2007/0149875 A1, published Jun. 28, 2007, now U.S. Pat. No. 8,515,518; 2009/0018425 A1, published Jan. 15, 2009, now U.S. Pat. No. 8,160,670; and U.S. patent application Ser. No. 12/625,524, filed Nov. 24, 2009, now U.S. Pat. No. 8,390,455; Ser. No. 12/625,525, filed Nov. 24, 2009, now U.S. Pat. No. 8,358,210; Ser. No. 12/625,528, filed Nov. 24, 2009, now U.S. Pat. No. 8,115,635; Ser. No. 12/628,201, filed Nov. 30, 2009, now U.S. Patent Publication No. 2010/0076280; Ser. No. 12/628,177, filed Nov. 30, 2009, now U.S. Patent Publication No. 2010/0076289; Ser. No. 12/628,198, filed Nov. 30, 2009, now U.S. Patent Publication No. 2010/0076291; Ser. No. 12/628,203, filed Nov. 30, 2009, now U.S. Patent Publication No. 2010/0076292; Ser. No. 12/628,210, filed Nov. 30, 2009, now U.S. Patent Publication No. 2010/0076293; Ser. No. 12/393,921, filed Feb. 26, 2009, now U.S. Patent Publication No. 2010/0213057; 61/149,639, filed Feb. 3, 2009; Ser. No. 12/495,709, filed Jun. 30, 2009, now U.S. Patent Publication No. 2010/0326842; 61/155,889, filed Feb. 26, 2009; 61/155,891, filed Feb. 26, 2009; 61/155,893, filed Feb. 26, 2009; 61/165,499, filed Mar. 31, 2009; 61/227,967, filed Jul. 23, 2009; 61/163,006, filed Mar. 23, 2009; Ser. No. 12/495,730, filed Jun. 30, 2009, now U.S. Patent Publication No. 2010/0331643; Ser. No. 12/495,712, filed Jun. 30, 2009, now U.S. Pat. No. 8,437,827; 61/238,461, filed Aug. 31, 2009; 61/256,925, filed Oct. 30, 2009; 61/238,494, filed Aug. 31, 2009; 61/238,159, filed Aug. 29, 2009; 61/238,483, filed Aug. 31, 2009; 61/238,581, filed Aug. 31, 2009; 61/247,508, filed Sep. 30, 2009; 61/247,516, filed Sep. 30, 2009; 61/247,514, filed Sep. 30, 2009; 61/247,519, filed Sep. 30, 2009; 61/249,535, filed Oct. 7, 2009; Ser. No. 12/544,061, filed Aug. 19, 2009, now U.S. Patent Publication No. 2011/0046466; Ser. No. 12/625,185, filed Nov. 24, 2009, now U.S. Pat. No. 8,354,013; Ser. No. 12/625,208, filed Nov. 24, 2009, now U.S. Pat. No. 9,042,954; Ser. No. 12/624,767, filed Nov. 24, 2009, now U.S. Patent Publication No. 2011/0124993; Ser. No. 12/242,780, filed Sep. 30, 2008, now U.S. Pat. No. 8,983,568; Ser. No. 12/183,602, filed Jul. 31, 2008, now U.S. Patent Publication No. 2010/0030052; Ser. No. 12/211,

014, filed Sep. 15, 2008, now U.S. Pat. No. 8,636,884; and Ser. No. 12/114,359, filed May 2, 2008, now U.S. Pat. No. 8,080,385, each of which is incorporated by reference in its entirety herein.

#### The Sensor

**[0086]** The analyte sensor **14** of the analyte measurement system **10** may be used to monitor levels of a wide variety of analytes. Analytes that may be monitored include, for example, acetyl choline, amylase, bilirubin, cholesterol, chorionic gonadotropin, creatine kinase (e.g., CK-MB), creatine, DNA, fructosamine, glucose, glutamine, growth hormones, hormones, ketones, lactate, peroxide, prostate-specific antigen, prothrombin, RNA, thyroid stimulating hormone, and troponin. The concentration of drugs, such as, for example, antibiotics (e.g., gentamicin, vancomycin, and the like), digitoxin, digoxin, drugs of abuse, theophylline, and warfarin, may also be monitored. One or more analyte may be monitored by a given sensor.

**[0087]** In one embodiment of the present disclosure, sensor **14** is physically positioned in or on the body of a user whose analyte level is being monitored. Sensor **14** may be configured to continuously sample the analyte level of the user and convert the sampled analyte level, e.g., glucose concentration into a corresponding data signal, e.g., a current or voltage, for input into sensor control unit electronics. Alternatively, sensor **14** may be configured to sample analyte levels on demand. The sensor control unit electronics may amplify, filter, or otherwise process the signal provided by the sensor.

**[0088]** The sensor may take on a number of forms. For example, the sensor may include a flexible or rigid substrate. In some embodiments, the sensor may be a wire. In some embodiments, the sensor may include two or three or more electrodes.

**[0089]** An embodiment of the sensor **14** is illustrated in FIG. 2. In some embodiments, sensor **14** includes a substrate which is a dielectric, e.g., a polymer or plastic material, such as polyester or polyamide. In this embodiment, the sensor is constructed so that a portion is positionable beneath skin and a portion is above skin. Accordingly, sensor **14** includes an insertion portion **30** and a contact portion **32**. The contact portion **32** typically includes several conductive contacts **36**, **38**, and **40** (herein shown as 3 contacts) for connection to other electronics, e.g., at the data processing unit **12**. The contacts provided in this embodiment are for a working electrode **36**, a reference electrode **38**, and a counter electrode **40**. In some embodiments, two or more working electrodes are provided. The operative portions of these electrodes, that is, working electrode, reference electrode, and counter electrode (not individually shown), are provided at the distal end of insertion portion **30**. The contact and operative portions of the electrodes are connected by circuit traces **42**, **44**, and **46** running on the surface of substrate. In some embodiments, the traces are provided in channels, or may be embedded within the substrate, or may traverse different sides of the substrate. The conductive contacts, conductive traces, and electrodes are fabricated from a conductive material, such as platinum, palladium, gold, or conductive carbon. Further details of sensors are described, e.g., in U.S. Pat. Nos. 6,175,572; 6,103,033, which are incorporated by reference herein.

**[0090]** Sensor **14** may include a proximal retention portion **48**. In some embodiments, the insertion portion **30** and the

proximal retention portion **48** are substantially longitudinally aligned. The insertion portion **30** and the proximal retention portion **48** are sized and configured to be positioned with a sharp for installation into the skin of a subject, as described herein. In use, the sensor **14** may be configured to bend (e.g., along the line B) and therefore be positioned in two substantially perpendicular, intersecting planes.

**[0091]** As illustrated in FIG. 3, sensor **14'** is substantially identical to sensor **14**, with many of the differences illustrated in FIG. 3 and noted herein. Sensor **14'** further includes additional features useful for connecting to, e.g., mounting to or in or on, a housing associated with the sensor control unit **12**. For example, sensor **14'** includes a laterally displaced portion (or sensor tab) **50'** and a longitudinal displaced portion **52'** which provide a path for electrical connections, e.g., the conductive traces. Sensor **14'** is further provided with a notch **54'** between the proximal retention portion **48'** and the longitudinal displaced portion **52'**. Such configuration permits the sensor **14'** to bend (e.g., along the line are indicated by line B) and therefore be positioned in two substantially perpendicular, intersecting planes, as illustrated in FIG. 4. As will be described below, the sensor tab **50'** can be encased in a portion of the body of the data processing unit **12** to aid in securing and positioning the sensor **14'**. Proximal retention portion **48'** maintains its longitudinal alignment with insertion portion **30'** for positioning within an insertion sharp.

**[0092]** FIG. 5 illustrates a further embodiment of a sensor **14''** in accordance with the disclosure. Sensor **14''** is substantially identical to sensor **14** and **14'**, with certain exemplary differences illustrated in FIG. 5 and noted herein. For example, sensor **14''** includes a contact portion **32''** which defines a fan-like configuration having a curved edge. Sensor **14''** defines a sensor flag indentation **56''** which also serves to assist in retaining the sensor **14''** in vertical direction, as will be described below, and provides a discrete location for mating with a feature of the data processing unit **12**, e.g., the bottom surface of a printed circuit board. Sensor **14''** is likewise capable of bending along axis B, as illustrated in FIG. 6. In any of the embodiments of the sensor described herein, the distance between insertion portion **30** to retention portion **48** may be, e.g., about 5 mm, or about 10 mm, or about 15 mm, or about 20 mm.

**[0093]** In general, sensors in accordance with the present disclosure operate electrochemically, through an arrangement of electrodes having chemical sensing layers applied thereto, by generating an electrical current proportional to the volume of a redox reaction of the analyte (and indicative of analyte concentration), catalyzed by an analyte-specific oxidizing enzyme. Embodiments exist in which the number of electrodes provided to bring about and detect the level of these reactions is two, three or a greater number.

**[0094]** A portion of sensor **14** (which collectively refers to sensors **14'** and **14''** herein) may be situated above the surface of the skin, with a distal portion **30** penetrating through the skin and into the subcutaneous space in contact with the user's biofluid, such as interstitial fluid. The disposition of the sensor in the illustrated embodiment is referred to as "transcutaneous". In general, the term "transcutaneous" as used herein refers to a sensor that is only partially inserted under one or more layers of the skin of the user, whereas the term "subcutaneous" refers to a sensor that is completely inserted under one or more layers of the skin of the user. It is understood that many features described

herein would be applicable to both transcutaneous and subcutaneous sensors. Further details regarding the electrochemistry of sensor **14** is provided in U.S. Pat. Nos. 5,264,104; 5,356,786; 5,262,035, 5,320,725, 6,990,366, each of which is incorporated herein by reference

**[0095]** In some embodiments, the sensor is implantable into a subject's body for a period of time (e.g., three to seven days, or in some embodiments, longer periods of up to several weeks) to contact and monitor an analyte present in a biological fluid. In this regard, the sensor can be disposed in a subject at a variety of sites (e.g., abdomen, upper arm, thigh, etc.), including intramuscularly, transcutaneously, intravascularly, or in a body cavity. In one embodiment, the sensor can be a transcutaneous glucose sensor. Alternatively, the sensor can be a subcutaneous glucose sensor.

**[0096]** In some embodiments, sensor **14** is employed by insertion and/or implantation into a user's body for some usage period. In such embodiments, substrate may be formed from a relatively flexible material to improve comfort for the user and reduce damage to the surrounding tissue of the insertion site, e.g., by reducing relative movement of the sensor with respect to the surrounding tissue.

**[0097]** While the embodiments illustrated in FIGS. 2-6 have three electrodes, other embodiments can include a fewer or greater number of electrodes. For example, a two electrode sensor can be utilized. The sensor may be externally-powered and allow a current to pass proportional to the amount of analyte present. Alternatively, the sensor itself may act as a current source in some embodiments. In some two-electrode embodiments, the sensor may be self-biasing and there may be no need for a reference electrode. An exemplary self-powered, two-electrode sensor is described in U.S. patent application Ser. No. 12/393,921, filed Feb. 26, 2009, and entitled "Self-Powered Analyte Sensor," which is hereby incorporated by reference in its entirety herein for all purposes. The level of current provided by a self-powered sensor may be low, for example, on the order of nanoamperes.

#### On-Body Unit

**[0098]** An exemplary configuration for sensor **14** (and sensors **14'** and **14''**) and sensor control unit **12** (e.g., collectively on-body unit **16**) is illustrated in FIGS. 7-8. Data processing unit **12**, may be provided with a substantially circular configuration having a reduced height (i.e., "Z"-dimension) to provide a low-profile when sitting on the skin of the subject. In some embodiments, the height is about 3 mm to about 25 mm, e.g., may be about 4 mm, about 5 mm, about 10 mm, or about 15 mm. In certain embodiments, the unit **12** may have a variable height. Data processing unit **12**, including its associated electronics **80**, are housed in a sensor housing **122**. For example, electronics may include, e.g., an analog interface for connecting to the sensor **14**, a processor, and a power supply. A serial communication section may be provided. A temperature sensor, such as a thermistor, which detects skin and or ambient temperature may be included to provide compensation to the analyte signal. A RF communication circuit is provided to communicate with the monitor unit **18**. A data storage unit may be provided to store analyte data points over a short term, e.g., several hours or minutes, or over a long term, e.g., several days or weeks. Additional optional electronics include a serial communication section, a leakage detection circuit, or user input, e.g., a switch to activate/deactivate some or all of

the device. Many of the components may be combined together and/or their function provided by common components. Furthermore, certain components may be eliminated entirely. For example, a power supply may be omitted if power is provided by inductive coupling.

**[0099]** In some embodiments, sensor **14** is disposed within the data transmitting unit **12**, e.g., in a bent configuration, as illustrated in certain embodiments herein, e.g., in FIGS. **4** and **6**. The contact portion **32** of sensor **14** may be oriented in a substantially horizontal configuration, and secured to a printed circuit board of the transmitter unit **12**. The insertion portion **30** of the sensor **14** extends in a substantially downwardly vertical orientation for placement in the skin of the subject. It is understood that sensor **14** may be disposed in other configurations, e.g., in an entirely substantially vertical configuration, etc. As a further example, the insertion portion **30** may be disposed at an oblique angle, e.g., between about  $0^\circ$  and about  $90^\circ$  with respect to the skin surface.

**[0100]** As illustrated in FIG. **9**, the on-body unit **16** communicates with the monitor unit **18**. Such communication may be one-way communication, e.g., from the on-body unit **16** to the monitor unit **18**. In some embodiments, the communication may be two-way, e.g., both from the on-body unit **16** to the receiving unit **18** and from the receiving unit **18** to the on-body unit **16**. In such cases, the receiving unit **18** may also be referred to herein as a display unit, transceiver or handheld unit. Communication between the on-body unit **16** and monitor unit **18** may occur via RF communication, inductive coupling, direct wired connection, etc.

#### Insertion Assembly

**[0101]** An insertion assembly is provided, which is used to install a medical device to the subject. In some embodiments, the insertion assembly includes an inserter and the medical device itself. The inserter can be configured to insert various medical devices to the subject, such as for example, an analyte sensor, an infusion set, a cannula, or a lancet. In some embodiments, the inserter can be configured to install a combination of such devices, e.g., a combined sensor/infusion set, etc. In certain embodiments, a given inserter can be configured to install a first device and a second device at different times. For example, an inserter may be modifiable to be used with more than one medical device, include more than one type of medical device, e.g., by attaching an adapter and/or removing detaching a portion of an inserter. The inserter can install the medical device transcutaneously in, under, or through the skin of the subject; or subcutaneously; or placed on the surface of the skin. The medical device can include features or structures, e.g., barbs, tabs, adhesive, etc., to maintain the device in position with respect to the skin after insertion.

**[0102]** In other embodiments, the insertion assembly includes an inserter, a medical device, such as an analyte sensor, and a mount for supporting the medical device at least partially in or on the skin of the subject. The mount may be inserted simultaneously with the medical device by the inserter. In other embodiments, the mount is installed after or before installation of the medical device. In such case the mount may be applied by the inserter or separately. The mount may include features or structures to maintain the sensor in position with respect to the skin after insertion.

**[0103]** In further embodiments, the insertion assembly includes an inserter, an analyte sensor, a mount, and a power supply. The mount and power supply may be inserted simultaneously with the analyte sensor by the inserter. In other embodiments, the mount and battery are installed after or before installation of the analyte sensor. In such case the mount and/or power supply may be applied by the inserter or separately.

**[0104]** In still further embodiments, the insertion assembly includes an inserter, a medical device such as an analyte sensor, a mount, and electronics. The mount and electronics may be inserted simultaneously with the analyte sensor by the inserter. In other embodiments, the mount and electronics are installed after or before installation of the analyte sensor. For example, the mount and the analyte sensor may be installed by the inserter, and the electronics may be subsequently installed. In other embodiments, the mount is installed, followed by insertion of the analyte sensor by the inserter, and further followed by installation of the electronics. In other embodiments, the mount and electronics are installed first, and the analyte sensor is subsequently installed.

**[0105]** In some embodiments, the electronics provide a voltage or current to the analyte sensor. In some embodiments, the electronics processes signals provided by the analyte sensor. In further embodiments, the electronics may include communication functionality for providing a signal relating to the signal provided by the analyte sensor to a further component, such as, e.g., a monitor unit, a handheld unit, a meter, a display unit, a computer, or other component. In some embodiments, communications circuitry, such as RFID antenna or communications circuitry is provided.

**[0106]** The inserter can include a plurality of different components. For example, the inserter may include one or more components for advancing a sharp towards the skin of the subject. The sensor and associated electronics and/or mounting structure may be supported by a support structure, such as a carriage. An actuator may be provided for advancing the sharp and/or the analyte sensor/support structure. In some embodiments, the actuator is coupled to the sharp and/or support structure, such that manual force and speed applied by the user to the actuator is transferred to the sharp and/or support structure.

**[0107]** The inserter can also include one or more components for retracting the sharp, while allowing the analyte sensor and optional mount and/or electronics to remain to the subject. The components for retracting the sharp can include a retractor. It is understood that the retractor and the actuator may be the same structure or include some common components. In some embodiments, the retractor is directly or indirectly coupled to the sharp such that the manual force applied by the user is transferred from the retractor to the sharp to retract the sharp from the skin. In other embodiments, a drive assembly may be provided to retract the sharp. For example, the drive assembly may include a spring, motor, hydraulic piston, etc., to retract the sharp away from the skin of the subject. The drive assembly may also include a linear drive component.

**[0108]** In some embodiments, the retractor withdraws the sharp upon actuation by the user. In such cases, the user actuates the retractor when it is desired to withdraw the sharp. For example, the retractor may include a release switch. Upon activation of the release switch, the drive assembly, e.g., the spring or other driver, retracts the sharp

from the skin. In other embodiments, the retractor and the actuator comprise common components. After activating the actuator to advance the sharp and the analyte sensor, the user releases the actuator, which allows the drive assembly to withdraw the sharp from the skin.

[0109] In some embodiments, the retractor withdraws the sharp without further user interaction after actuation of insertion. For example, the inserter may include features or components which automatically retract the sharp upon advancement of the sharp and support structure by a predetermined amount. Inserter devices, in which no further action by the user is required to initiate withdrawal of the sharp after insertion, are referred to herein as having “automatic” withdrawal of the sharp.

#### Inserter Devices

[0110] An inserter **100** in accordance with an exemplary embodiment is illustrated in FIG. **10**. Inserter **100** includes a handle **102** and a removable distal cap **104**. The cap **104** may maintain a sterile, contaminant-free environment for the medical device and sharp housed therein. As illustrated in FIGS. **10-16**, distal cap **104** is secured to handle **102**, e.g., by use of one or more mating members, e.g., threads **110** and **111**, or hooks, tape, and the like. Inserter **100** includes a base **142** which defines a distal, substantially planar surface **112** for placement on the skin **S** of a subject, and in other embodiments may be a curved or inclined surface, e.g., a concave or convex surface. Inserter **100** may be utilized to advance a medical device into the skin of the subject, e.g., an analyte sensor, and infusion set, etc. In some embodiments, handle **102** is advanced relative to base **142** in order to advance the medical device into the skin of the patient, as will be described in greater detail herein.

[0111] The components of inserter **100** are illustrated in FIGS. **11-27**. As illustrated in FIG. **11**, handle **102** includes a contact surface **114** for contact by a user to insert and install the sensor housing **122** and sensor **14**. Threads **110** are provided on handle **102** for attachment to cap **104** via threads **111** (as illustrated in FIGS. **12-13**). Cap **104** can include an upwardly extending boss **125** to assist positioning of the sharp **124**. The distal portion of cap **104** includes a recess **115** for retaining a desiccant **190** therein. In some embodiments, a silica gel or molecular sieves may be used. Such material can be in either in granular form (pellets) or pressed into tablets. In some embodiments, silica gel tablets are used.

[0112] Cap **104** is provided with one or more apertures **117**, which allows for passage of air to the desiccant **190** to remove moisture from the interior of the inserter **100**. Cap **104** includes an annular ridge **113** which engages the distal edge portion **116** of handle **102**. In some embodiments, annular ridge **113** prevents distal movement of handle **102** (as well as sharp **124**) when cap **104** is attached to handle **102**.

[0113] Base **142**, as illustrated in FIGS. **10** and **14**, includes a distal sheath portion **192**, which shields sharp **124** prior to deployment and a distal rim **112** having a substantially planar surface configuration to rest on the subject's skin. Base **142** also includes side walls **191**, which along with inner rail **128** defines a recess for retraction spring **146**. Base **142** provides a spring floor **148**, as illustrated in FIG. **29**.

[0114] Support member or shuttle **134**, as illustrated in FIGS. **15-16**, supports needle hub **136**, from which sharp

**124** extends longitudinally within the inserter **100**. In some embodiments, the sharp is supported at an oblique angle, e.g., between about  $0^\circ$  and about  $90^\circ$  with respect to the skin surface. Needle hub **136** can be secured to shuttle **134** via an interlocking O-ring configuration, adhesive, or other techniques known in the art. In some embodiments, sharp **124** is a solid needle. In some embodiments, sharp **124** is provided with a substantially cylindrical configuration defining an interior bore, e.g., a rigid cannula or a hypodermic-style needle.

[0115] Needle hub **136** is further illustrated in FIGS. **17-18**. Needle hub **136** supports sharp **124**, having a sharpened distal portion **160**. In some embodiments, as discussed herein, a longitudinal wall opening or gap **162** is provided in at least a portion of the wall of the sharp **124**. The length **N** of the gap **162** is selected to be commensurate with the length of the insertion portion **30** through to the proximal retention portion **48** of the sensor, or about 5 mm, or about 10 mm, or about 15 mm, or about 20 mm. The length **L** of the sharp **124** may be about 5 mm, or about 10 mm, or about 20 mm, about 30 mm, or about 50 mm, and is selected based upon the desired depth of the insertion portion **30** of the sensor **14**.

[0116] The distal portion **160** of sharp **124** is illustrated in greater detail in FIGS. **19-21**. As illustrated in FIG. **19**, sharp **124** has a substantially “C”- or “U”-shaped profile in this embodiment, but may have other configurations, e.g., substantially “V”-shaped. A longitudinal gap **162** is provided in the wall of the sharp **124**. FIG. **20** illustrates distal portion **160** is provided with an angled tip. In some embodiments, the angled tip may be provided with a first angled tip portion **164** and a second steep-angled tip portion **166**. The exemplary configuration, which includes multiple edges and faces, provides a sharp point to reduce penetration force, trauma, and bleeding for the subject. The distal section of the sensor body has a width sized to fit within the notch **162** of the insertion sharp **124** having a diameter less than about 22 to about 24 gauge, in certain embodiments the sharp is 25 gauge. In some embodiments, sharp **124** is a fabricated from a sheet of metal, and folded into a substantially “V” or “U” or “C” configuration in cross-section. In some embodiments, a laser is used to form the wall opening or gap **162**.

[0117] FIGS. **22-23** illustrate the position of sensor housing **122** with respect to the needle hub **136** and sharp **124**. As illustrated in FIG. **22**, the sharp **124** extends through an aperture **168** in the sensor housing **122**. The distal portion of sensor **14** is positioned with the sharp **124**. As further illustrated in FIG. **23**, electronics **80** (e.g., a printed circuit board containing ASIC electronics) and sensor hub **123** are positioned within sensor housing **122**. A power supply **82**, such as a battery, e.g., a single use disposable battery, or rechargeable battery, is provided. In some embodiments, the active operational life of the battery may exceed the active operational life of the sensor **14**.

[0118] FIG. **24** illustrates in cross-section the orientation of the sensor housing **122** with respect to the sharp **124** of inserter **100**. As discussed herein, sensor **14** is disposed in a substantially bent configuration, such that a portion of the sensor, e.g., the insertion portion **30** and the proximal retention portion **48** are substantially vertical (e.g., substantially aligned with the longitudinal axis of the inserter **100** and substantially perpendicular to the skin surface) and the contact portion **32** (shown in profile) is oriented in a substantially horizontal configuration, and in electrical contact

with the data processing unit electronics, such as circuit 80. The sensor tab 50 can be encased in the plastic of the sensor housing 122 (e.g., “overmolded”) and secured in place. The notch 56 provides further stability to the sensor 14, e.g., by allowing the sensor tab 50 to be encased by the material of the sensor housing 122, and further provides a means for vertically orienting the sensor 14 during mounting, e.g., by allowing vertical positioning of the notch 56 with respect to a vertical landmark of the housing 122.

[0119] The sensor 14, mounted with the sensor housing 122, is disposed within the concave recess in the carriage 130. In the initial configuration of the inserter 100 (see, e.g., FIGS. 10 and 28-29) the sharp 124 extends through a longitudinal aperture 168 formed in a carriage 130. In some embodiments, the aperture 168 is appropriately sized, such that neither the sharp 124 nor needle hub 136 is in contact with the carriage 130. Accordingly, the needle hub 136 (and sharp 124) on the one hand, and the carriage 130 and the sensor housing 122, on the other hand, move simultaneously but independently from one another. In other embodiments, a friction fit may be provided between the aperture and the sharp.

[0120] The insertion portion 30 and proximal retention portion 48 of the sensor 14 are disposed within a longitudinal bore 162 within the sharp 124. (See, e.g., FIG. 19) The proximal retention portion 48 is disposed within the longitudinal bore of the sharp and provides additional stability to the mounting of the sensor 14 within the sharp 124. The longitudinal wall gap or opening 162 of sharp 124 is aligned with the sensor 14, such that the tab 50 and the contact portion 32 extend laterally outward from the sharp 124.

[0121] With continued reference to FIGS. 15 and 16, shuttle 134 includes wings 182 and resilient distally-extending fingers 184. Inner rail 128 is illustrated in FIG. 25. As illustrated in FIG. 26, shuttle 134 is sized and configured for slidable movement within inner rail 128. Wings 182 of shuttle 134 are configured for slidable movement within axial notches 188 of inner rail 128. When fingers 184 of shuttle 134 are disposed in their normally biased outward position, fingers 184 engage the lower surface 194 of inner rail 128. In the configuration illustrated in FIG. 26, shuttle 134 is locked with respect to inner rail 128. As will be discussed herein, fingers 184 may be biased radially inward to allow upward movement of shuttle 134 relative to inner rail 128.

[0122] As illustrated in FIG. 10, inner rail includes an upper surface 186 for engagement with handle 102. In some embodiments, surface 186 is adhered or otherwise fixed to handle 102.

[0123] The relationship of inner rail 128, shuttle 134 and base 142 is illustrated in FIG. 27. In an initial configuration, inner rail 128 and shuttle 134 are in a locked relationship by engagement of wings 182 and fingers 184. Inner rail 128 and shuttle 134 are axially movable within base 142. Spring 146, which is secured between spring floor 148 of base 142 and wings 182 of shuttle 134 biases the inner rail 128 and shuttle 134 in a proximal (upward) direction.

[0124] Inserter 100 is illustrated in section in FIGS. 28-29 prior to use in a sensor pre-deployment position. Cap 104 is attached to the distal portion of inserter 100, via inter-engagement of threads 110 and 111.

[0125] As illustrated in FIG. 28, the inserter 100 includes an initial configuration in which the handle 102 is disposed in a proximal position with respect to the base 142. In such

configuration, the sharp 124 is disposed in a configuration spaced apart from an aperture of the adhesive layer 118.

[0126] As illustrated in FIG. 30, inner rail 128 includes a carriage 130. In a sensor insertion position, the handle 102 is depressed downward (arrow D) against the bias of spring 146, the inner rail 128 moves downwardly with the carriage 130 and the sensor housing 122. Shuttle 134 supports needle hub 136, from which sharp 124 extends longitudinally within the inserter 100. Initially shuttle 134 is coupled to inner rail 128 via inter-engagement of fingers 184 of shuttle 134 with distal surface 194 of inner rail 128, and both shuttle 134 and inner rail 128 move distally together as a unit.

[0127] As the sharp 124 is urged distally (FIG. 30), it carries the sensor insertion portion 30 of sensor 14 into the subcutaneous portion of the subject’s skin S and into contact with the interstitial fluid. As carriage 130 reaches a distal position, the distal surface of the sensor housing 122 engages the upper surface of adhesive pad 118, thereby becoming adhered to the skin surface S of the subject.

[0128] Flanges 170 on base 142 engage fingers 184 of shuttle 134. Fingers 184 are pivoted or bend inwards by contact with flanges 170 (as indicated by arrows F).

[0129] As illustrated in FIG. 31, such pivoting of fingers 184 causes fingers 184 to become disengaged from distal edge 194 of inner rail 128. Shuttle 134 is thereby disengaged from inner rail 128. Disengagement of the shuttle 134 from the inner rail 128 permits the spring 146 to expand, thereby advancing the shuttle 134 to a proximal position, and withdrawing the sharp 124 from the sensor 14 and the skin S of the subject, while leaving the sensor 14 in the skin. Once the sharp has been withdrawn from the subject, it is no longer accessible from the distal portion of the inserter 100, which prevents accidental needle sticks. When the carriage 130 reaches the distal position in which flanges 170 engage fingers 184 of needle shuttle 134, needle shuttle 134 withdraws needle 124 automatically without further input from the user.

[0130] Prior to activation of the integrated sensor 14 and sensor electronics assembly 16 for use, there may be a period of time from the manufacturing that the assembly 16 may be in a “sleep” or “idle” mode. With a power supply such as a battery integrated within the assembly, for reasons including cost optimization and prolonging shelf life, embodiments of the present disclosure include systems that are activated merely by positioning the sensor 14 and electronics unit 16 on a skin surface as described above, i.e., no additional action may be required of the user other than applying a force to housing 122. As such, insertion of the sensor 14 and/or mounting of the housing 122 causes activation of the electronics 80. In certain embodiments, activation switch configurations are included which may be configured to be triggered, for example, by the insertion device activation, thereby turning on the integrated sensor and sensor electronics assembly into an active mode.

[0131] As illustrated in FIG. 29, inserter 100 is also provided with a plunger switch 185, which provides automatic activation of the electronics 80 of the data processing unit 12. In some embodiments, the plunger switch 185 is a longitudinally slidable member disposed on the distal surface of the sensor housing 122. When the sensor housing is advanced proximally, it engages the adhesive pad 118, or alternatively the skin surface of the subject. Upon such engagement, the plunger switch 185 is moved axially (proximally) with respect to the housing 122. The plunger switch



in the proximal position is shown in FIG. 30, for example. Such axial movement is used to activate the sensor electronics 80. In some embodiments, the plunger switch is spring biased. Accordingly, as long as the sensor housing is maintained in a fixed relationship with the adhesive pad 118 against the bias, electronic activation is maintained. If the sensor housing is removed from the adhesive or the skin, the plunger switch moves with the bias, and the electronics are deactivated. In other embodiments, the plunger switch provides a one-time activation of the electronics. In such cases, once the electronics are activated, the sensor housing is not required to remain in contact with the adhesive or the skin in order to maintain activation.

[0132] As illustrated in FIGS. 32-33, embodiments of a power supply switch mechanism include conductive plugs of the on-body integrated sensor and sensor electronics assembly 16 in accordance with the present disclosure. FIGS. 32-33 illustrate enlarged sectional views of sensor housing 122. As shown, the sensor electronics assembly circuit board 710 may be provided with a physical gap 750 that breaks the electrical circuit between the power supply (e.g., battery) and the other circuitry of the sensor electronics assembly.

[0133] In one embodiment, when the predetermined force is applied on the insertion device 100 as discussed above, a conductive portion 720 provided within the housing 122 of the sensor electronics may be moved in a direction as shown by arrow 730 such that electrical contact is established in the physical gap 750 on the circuit board, by for example, the conductive portion 720 coming into physical contact with the conductive portions 760 of the circuit board 710. In this manner, in one embodiment, the electrical path from the power supply and the remaining circuitry on the circuit board of the sensor electronics is completed, thereby powering the sensor electronics.

[0134] By way of another example, referring to FIG. 33, the conductive portions 760 of the circuit board are provided on the board itself, and the conductive plug 740, for example, when pushed into the cavity 750, establishes electrical contact between the conductive portions 760 of the circuit board.

[0135] In one embodiment, as discussed above, the actuation of the insertion device 100 to position the sensor and sensor electronics assembly triggers the switch mechanism shown in FIGS. 32-33 by also moving the conductive portion 720 or the conductive plug 760 in the direction complimentary to the direction of the introducer movement, and thereby switching on the sensor electronics. Within the scope of the present disclosure, the activation of the sensor electronics by moving the conductive portion 720 or the conductive plug may include a separate procedure, where after positioning the sensor and the sensor electronics assembly on the skin surface, a predetermined force is applied on the housing of the integrated sensor 14 and sensor electronics assembly such that the desired movement of the conductive portion 720 or the conductive plug 760 may be achieved.

[0136] FIGS. 34A-36B illustrate another configuration of the power supply switch mechanism including conductive pads of the on-body integrated sensor and sensor electronics assembly in accordance with embodiments of the present disclosure. Referring to FIG. 34A, an exposed conductive ring 771 may be provided and configured to contact the surface of the circuit board in the sensor housing 122 (shown

in cross section in FIG. 34B) such that, the insertion device activation positions the conductive ring 771 on the surface of the circuit board so as to complete the electrical contact of the sensor housing 122 (by for example, manual force applied on the insertion device placing the conductive ring in contact with the circuit board of the sensor electronics).

[0137] Referring to FIGS. 35A-B, in another aspect, electrical contact pads 772, 773 may be provided to the circuit board in the sensor housing 122 (shown in cross section in FIG. 35B, such that the mating of the contact pads with the conductive ring 771 switches on the sensor electronics device to provide power to the device from its power source. FIGS. 36A-B show yet another configuration of the switch activation mechanism in accordance with the present disclosure, where a portion of the conductive ring 774 is selectively positioned and provided to establish electrical contact in the sensor housing 122 (shown in cross section in FIG. 36B).

[0138] As discussed, each of the activation configurations described above includes a break in the circuitry from the power source such that the power supply is not drained when the device is not in use, and upon activation, the break in the electrical contact is completed, thereby powering the device and activating it for operation.

[0139] FIG. 37 illustrates a power supply switch mechanism including an internal switch with a push rod activation of the on-body integrated sensor and sensor housing 122 in accordance with embodiments of the present disclosure. As shown, in one embodiment, push rod 810 may be provided and positioned in the sensor electronics such that when a force is applied in the direction as shown by arrow 830, the push rod 810 is displaced in the same direction and completes the electrical contact between the two contacts 820, 821. In one aspect, the push rod 810 may be provided within a seal 840 such as an O-ring or similar components.

[0140] FIG. 38 illustrates power supply switch mechanism including introducer retraction trigger activation of the on-body integrated sensor and sensor housing 122 in accordance with embodiments of the present disclosure. As shown, a nonconducting needle or device 910 is provided to physically separate two electrical contacts 920, 921. Each of the electrical contacts 920, 921 is biased or spring loaded to be urged towards each other, physically separated by the nonconducting needle 910. Accordingly, when the nonconducting needle 910 is retracted or pulled away from the sensor electronics assembly in the direction as shown by arrow 930, the electrical contacts 920, 921 are configured to contact each other, thereby completing the break in the circuit and establishing electrical connection to activate the sensor electronics assembly. In one aspect, the nonconducting device or needle 910 may include, for example, but not limited to, glass, plastic or any other material suitable to separate two electrical contacts and provide insulation therebetween.

[0141] FIG. 39 illustrates power supply switch mechanism with a contact switch of the on-body integrated sensor and sensor electronics assembly in accordance with embodiments of the present disclosure. As shown, in a further aspect, there is provided an electronic switch 1001 (that is configured to draw an insubstantial amount of power from the sensor electronics power supply), and when triggered, completes the break between the contacts 1010, 1011 by physically contacting the two contacts 1010, 1011 with the activation component 1002 that completes the circuit in the

sensor electronics from its power supply such as battery to activate the device for operation.

**[0142]** FIGS. 40-41 illustrate a power supply switch mechanism with a battery contact locking mechanism of the on-body integrated sensor and sensor electronics assembly 122 in accordance with the present disclosure. Referring to FIGS. 40-41, in still another aspect, the battery contact of the sensor electronics may be provided with a barbed tab 1110. In post manufacturing shelf mode when the device is non-operational, the tab 1110 is positioned within the sensor electronics housing in the position as shown in FIG. 40 so that it is not in contact with the conductive contact 1120 of the sensor electronics circuit board. When in use as shown in FIG. 41, the tab 1110 may be biased such that it physically contacts the conductive contact 1120 on the circuit board, thereby closing the circuit to/from the battery/power source and thus activating or switching on the sensor electronics. As shown in the Figures, the tab 1110 may be configured that upon biasing to establish contact with the conductive contact 1120, it locks or latches with the conductive contact 1120 and the circuit board so as to maintain the electrical connection.

**[0143]** FIGS. 42-43 illustrate power supply switch mechanism with a bi-modal dome switch of the on-body integrated sensor and sensor electronics assembly in accordance with embodiments of the present disclosure. Yet in another embodiment, a bi-modal dome shaped switch 1210 is provided on the circuit board of the sensor electronics assembly such that, when pressed down (as shown in FIG. 42), the dome shaped layer 1210 (which may include, for example, a thin sheet metal dome) may be configured to retain the concave shape as shown in FIG. 43 and effectively closing the circuit on the circuit board at the contact point 1220. In one aspect, the dome shaped layer 1210 may be configured to shunt to short two or more electrical contacts at the contact point 1220 of the circuit board. Alternatively, the dome shaped layer 1210 may be connected to the circuit board such that one end of the dome shaped layer 1210 is in contact with one of the two or more open electrical contacts, and the depression of the dome shaped layer 1210 closes the circuit on the circuit board by physically contacting the other one or more of the open electrical contacts.

**[0144]** In the manner described above, in accordance with various embodiments of the present disclosure, sensor electronics activation switch configurations are provided that may be triggered or activated automatically or semi-automatically in response to the activation of the insertion device described above, or alternatively, may be separately activated by the user by, for example, depressing upon a portion of the housing or switch provided on the housing of the sensor electronics. Accordingly, power consumption may be optimized for the sensor electronics assembly while improving post manufacturing shelf life of the device prior to use or activation.

**[0145]** It is understood that the subject matter described herein is not limited to particular embodiments described, as such may, of course, vary. It is also understood that the terminology used herein is for the purpose of describing particular embodiments only, and is not intended to be limiting, since the scope of the present subject matter is limited only by the appended claims.

**[0146]** Additional detailed description of embodiments of the disclosed subject matter are provided in but not limited to: U.S. Pat. Nos. 7,299,082; 7,167,818; 7,041,468; 6,942,

518; 6,893,545; 6,881,551; 6,773,671; 6,764,581; 6,749,740; 6,746,582; 6,736,957; 6,730,200; 6,676,816; 6,618,934; 6,616,819; 6,600,997; 6,592,745; 6,591,125; 6,560,471; 6,540,891; 6,514,718; 6,514,460; 6,503,381; 6,461,496; 6,377,894; 6,338,790; 6,299,757; 6,299,757; 6,284,478; 6,270,455; 6,175,752; 6,161,095; 6,144,837; 6,143,164; 6,121,009; 6,120,676; 6,071,391; 5,918,603; 5,899,855; 5,822,715; 5,820,551; 5,628,890; 5,601,435; 5,593,852; 5,509,410; 5,320,715; 5,264,014; 5,262,305; 5,262,035; 4,711,245; 4,545,382; U.S. Patent Publication No. 2004/0186365, published Sep. 23, 2004, now U.S. Pat. No. 7,811,231; U.S. Patent Application No. 61/238,646, filed Aug. 31, 2009, the disclosures of each of which is incorporated herein by reference.

1-20. (canceled)

21. An assembly, comprising:

an inserter device configured to advance an on-body unit from a first position in the inserter device to a second position on skin of a subject; and

the on-body unit comprising a housing and sensor electronics disposed therein, wherein the sensor electronics comprise a battery, a first electrical contact, and a second electrical contact,

wherein the first electrical contact and the second electrical contact are not electrically coupled when the on-body unit is in the first position, and

wherein the inserter device is further configured to be activated to cause a displaceable portion of the assembly to be displaced to cause the battery, the first electrical contact, and the second electrical contact to become electrically coupled.

22. The assembly of claim 21, wherein the sensor electronics further comprise a processor, a data storage unit, an analog interface, and communication circuitry.

23. The assembly of claim 22, wherein the sensor electronics are in a sleep mode or an idle mode when the on-body unit is in the first position.

24. The assembly of claim 22, wherein the sensor electronics are in an active mode when the on-body unit is in the second position.

25. The assembly of claim 21, wherein the displaceable portion of the assembly is a plunger switch of the on-body unit.

26. The assembly of claim 21, wherein the displaceable portion of the assembly comprises a conductive portion of the on-body unit.

27. The assembly of claim 26, wherein the conductive portion of the on-body unit comprises a conductive plug.

28. The assembly of claim 26, wherein the conductive portion of the on-body unit comprises a conductive ring.

29. The assembly of claim 21, wherein the displaceable portion of the assembly comprises a non-conductive portion.

30. The assembly of claim 29, wherein the non-conductive portion is disposed between the first electrical contact and the second electrical contact when the on-body unit is in the first position.

31. The assembly of claim 30, wherein the first electrical contact is biased toward the second electrical contact.

32. The assembly of claim 31, wherein the non-conductive portion is configured to be displaced after activation of the inserter device such that the non-conductive portion is no longer disposed between the first electrical contact and the second electrical contact.

33. The assembly of claim 29, wherein the non-conductive portion comprises a needle.

**34.** The assembly of claim **33**, wherein the needle is configured to be displaced in a proximal direction away from the skin of the subject to cause the battery, the first electrical contact, and the second electrical contact to become electrically coupled.

**35.** The assembly of claim **21**, wherein the inserter device comprises a needle, and wherein the displaceable portion of the assembly is configured to be displaced in a direction complementary to a direction of the needle during an insertion process.

**36.** The assembly of claim **21**, wherein the displaceable portion of the assembly is configured to deform after activation of the inserter device.

**37.** The assembly of claim **21**, wherein the displaceable portion of the assembly comprises a tab configured to couple with the first electrical contact or the second electrical contact.

**38.** The assembly of claim **21**, wherein the displaceable portion of the assembly comprises a bi-modal dome structure.

**39.** The assembly of claim **21**, wherein the displaceable portion of the assembly is configured to be displaced to a concave shape.

**40.** The assembly of claim **21**, wherein the battery, the first electrical contact, and the second electrical contact form an open electrical circuit when the on-body unit is in the first position.

**41.** The assembly of claim **21**, wherein the battery, the first electrical contact, and the second electrical contact form a closed electrical circuit when the on-body unit is in the second position.

\* \* \* \* \*