



US 20210015628A1

(19) **United States**

(12) **Patent Application Publication**
Zubok et al.

(10) **Pub. No.: US 2021/0015628 A1**

(43) **Pub. Date: Jan. 21, 2021**

(54) **INSTRUMENTATION AND METHODS FOR USE IN IMPLANTING A CERVICAL DISC REPLACEMENT DEVICE**

Publication Classification

(71) Applicant: **Howmedica Osteonics Corp.**, Mahwah, NJ (US)

(51) **Int. Cl.**
A61F 2/44 (2006.01)
A61B 17/70 (2006.01)
A61B 17/80 (2006.01)
A61B 17/86 (2006.01)
A61F 2/46 (2006.01)

(72) Inventors: **Rafail Zubok**, Midland Park, NJ (US);
Michael W. Dudasik, Nutley, NJ (US);
Joseph P. Errico, Warren, NJ (US)

(52) **U.S. Cl.**
CPC *A61F 2/4425* (2013.01); *A61B 17/7059* (2013.01); *A61B 17/8033* (2013.01); *A61B 17/8042* (2013.01); *A61F 2002/30843* (2013.01); *A61F 2/4611* (2013.01); *A61F 2/4684* (2013.01); *A61F 2/442* (2013.01); *A61B 17/8625* (2013.01)

(21) Appl. No.: **17/031,044**

(22) Filed: **Sep. 24, 2020**

Related U.S. Application Data

(63) Continuation of application No. 16/193,503, filed on Nov. 16, 2018, now Pat. No. 10,835,385, which is a continuation of application No. 15/434,436, filed on Feb. 16, 2017, now Pat. No. 10,159,578, which is a continuation of application No. 14/623,151, filed on Feb. 16, 2015, now Pat. No. 9,603,716, which is a continuation of application No. 13/856,491, filed on Apr. 4, 2013, now Pat. No. 8,961,608, which is a continuation of application No. 12/564,554, filed on Sep. 22, 2009, now Pat. No. 8,435,297, which is a continuation of application No. 10/781,484, filed on Feb. 18, 2004, now Pat. No. 7,618,439, which is a continuation of application No. 10/688,632, filed on Oct. 17, 2003, now Pat. No. 6,896,676, which is a continuation-in-part of application No. 10/382,702, filed on Mar. 6, 2003, now Pat. No. 6,908,484.

(57) **ABSTRACT**

Instrumentation for implanting a cervical disc replacement device includes cervical disc replacement trials for determining the appropriate size of replacement device to be implanted, an insertion plate for maintaining the elements of the replacement device in fixed relation to one another for simultaneous manipulation, an insertion handle for attachment to the insertion plate for manipulation of the elements, an insertion pusher for releasing the insertion handle from the insertion plate, a drill guide that cooperates with the insertion plate to guide the drilling of tap holes for bone screws to be placed through bone screw holes in the flanges of the replacement device, clips that are applied to the flanges after placement of the bone screws to resist screw backout, and a clip applicator for applying the clips to the flanges.

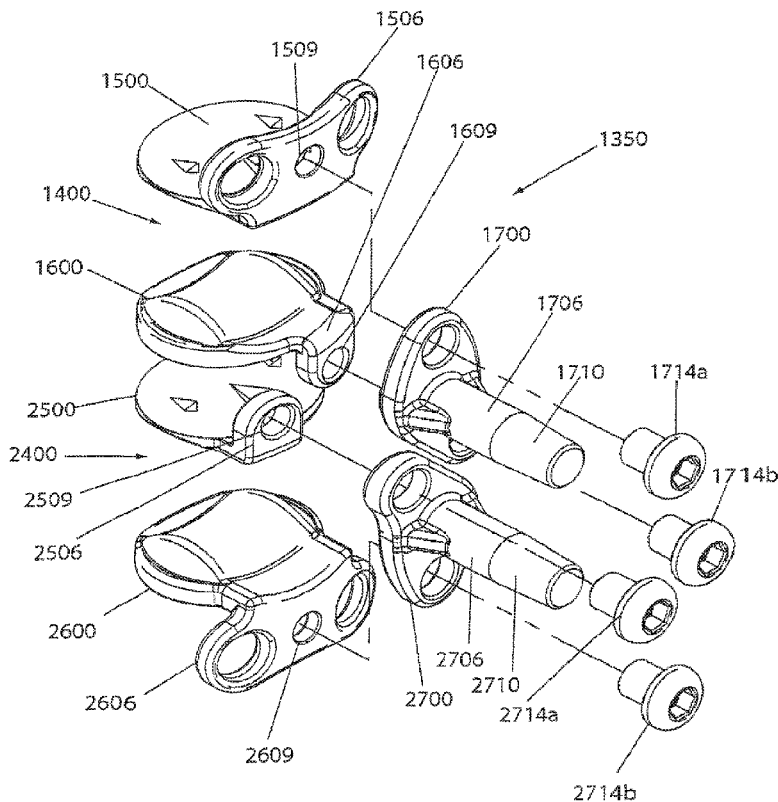

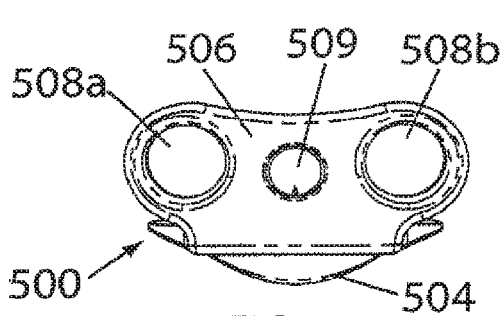

FIG. 1a

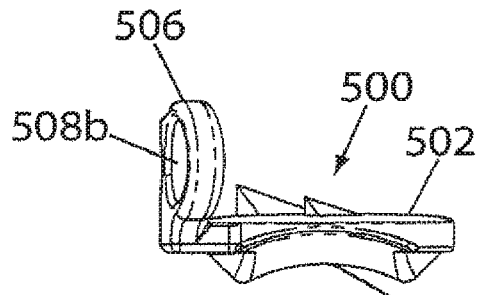

FIG. 1b

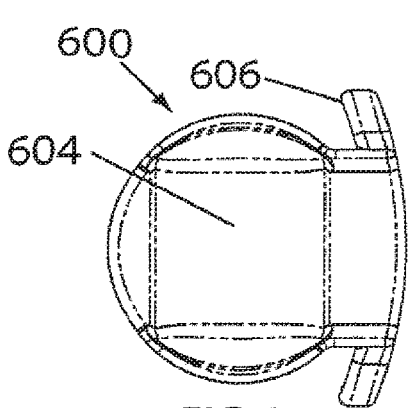

FIG. 2c

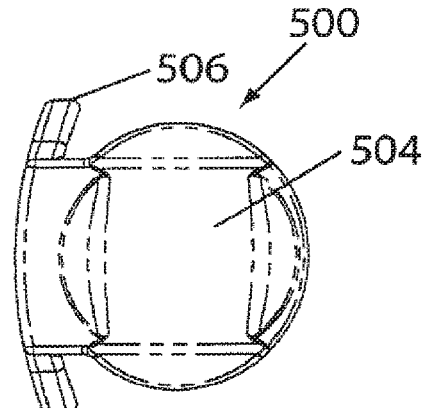

FIG. 1c

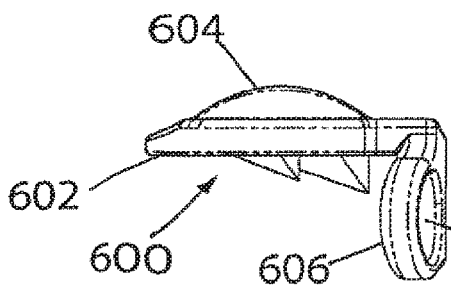

FIG. 2b

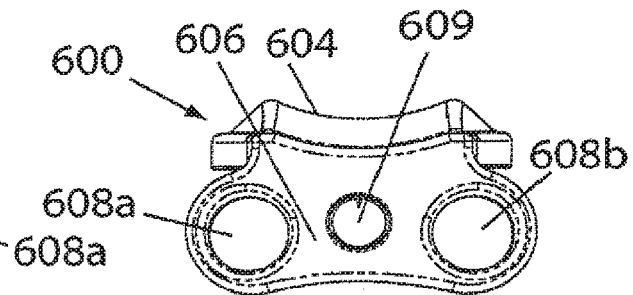

FIG. 2a

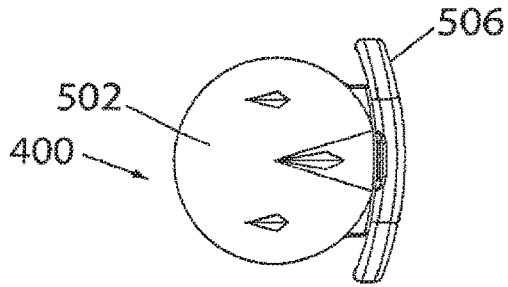

Fig. 3a

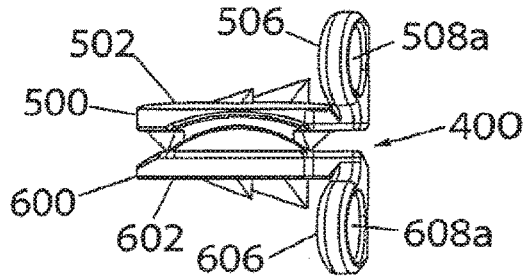

Fig. 3b

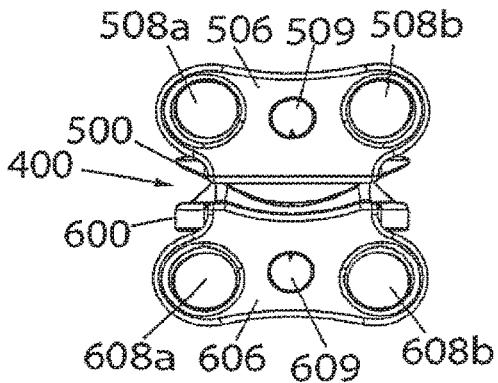

Fig. 3c

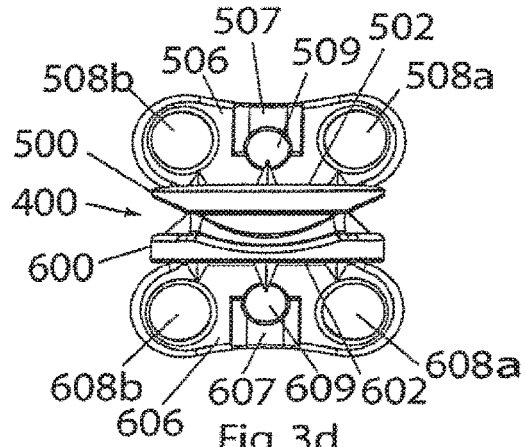

Fig. 3d

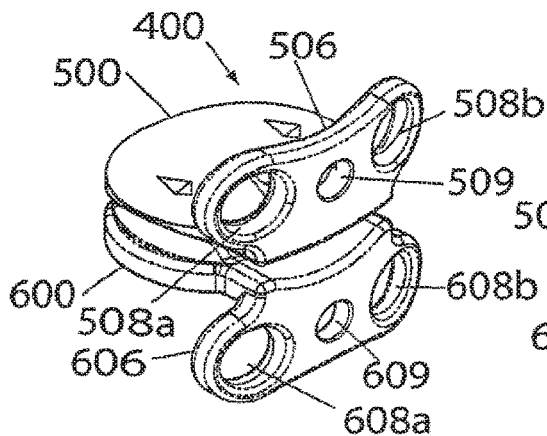

Fig. 3e

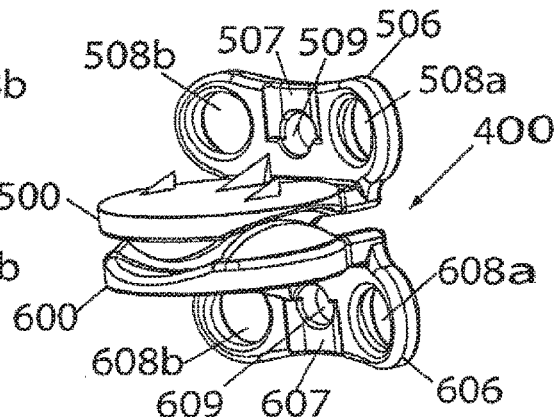
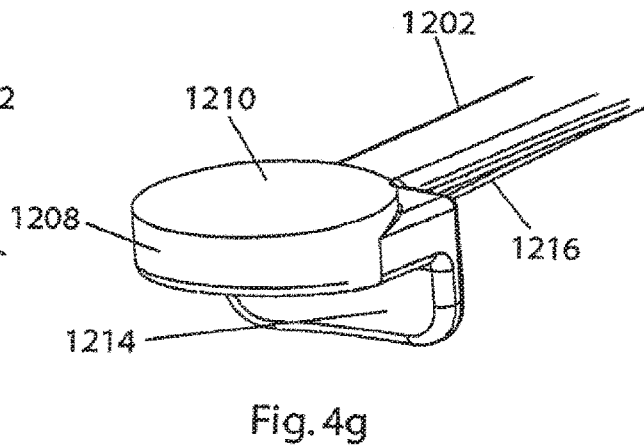
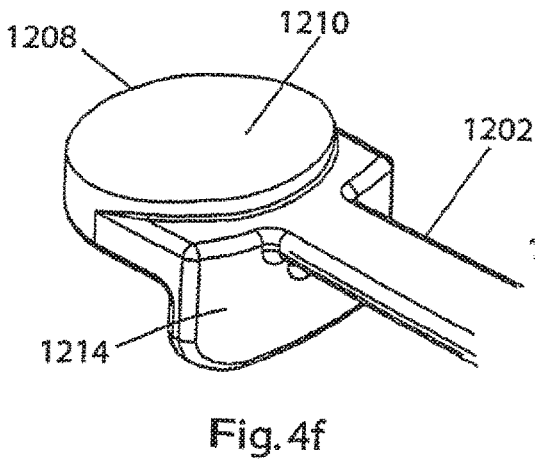
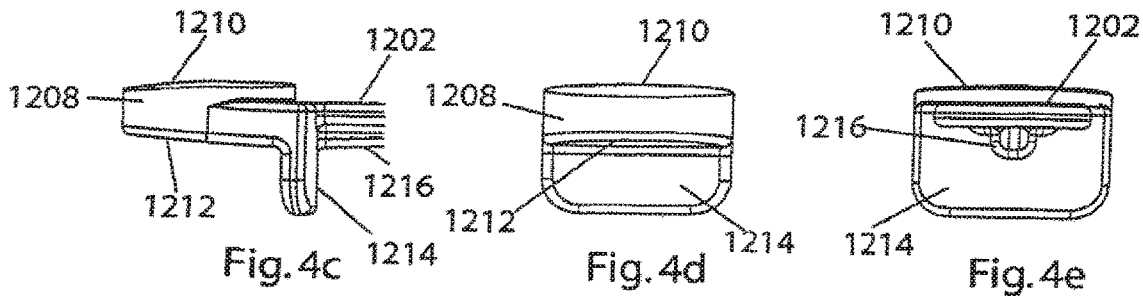
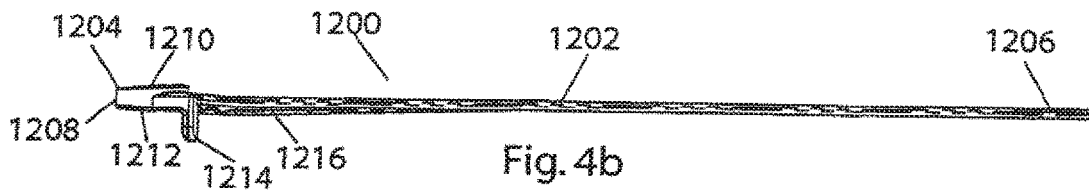
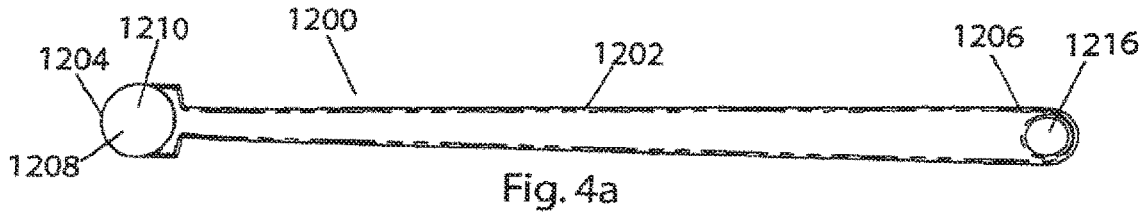
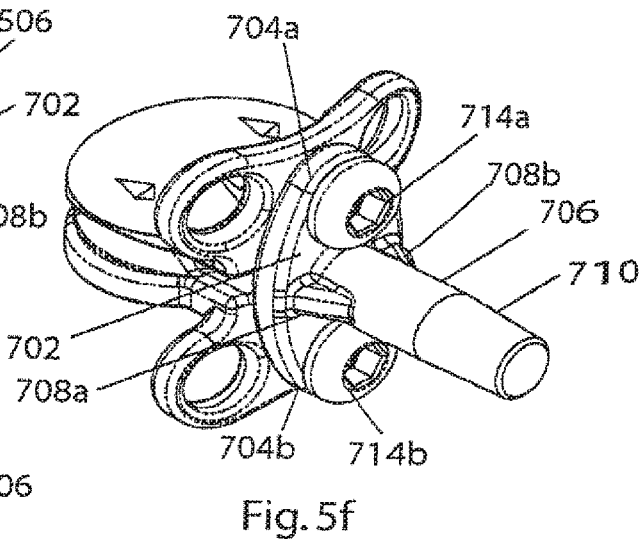
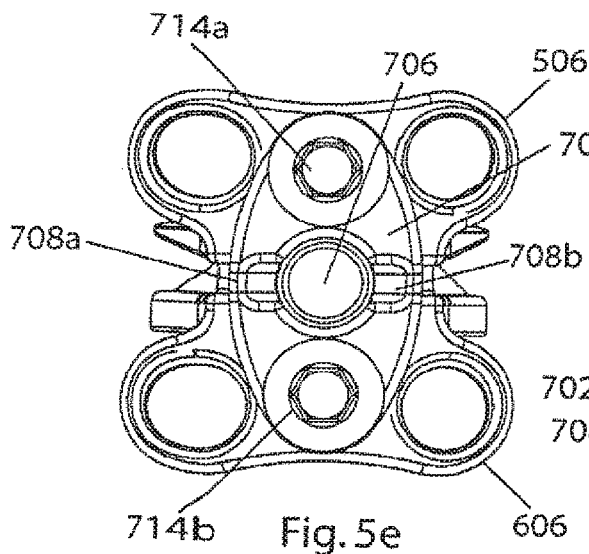
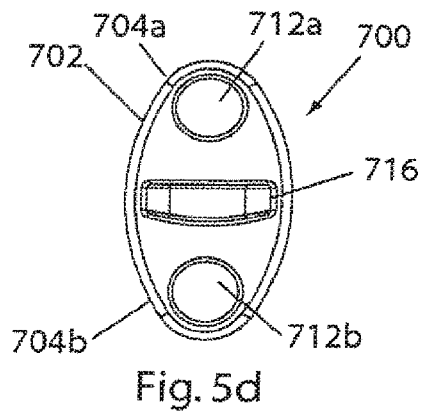
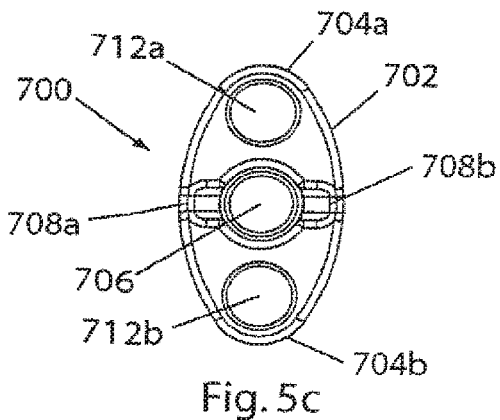
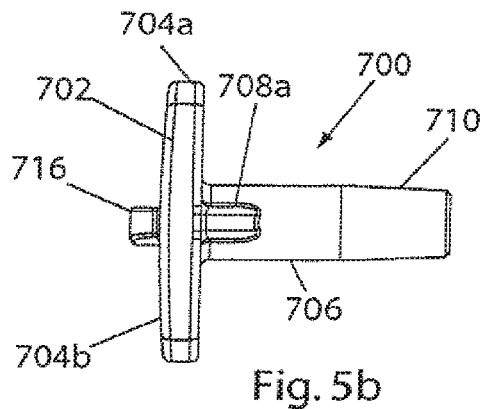
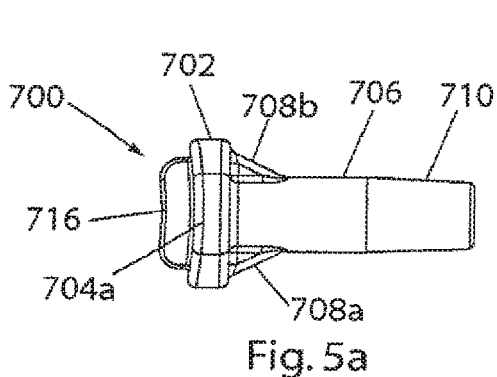
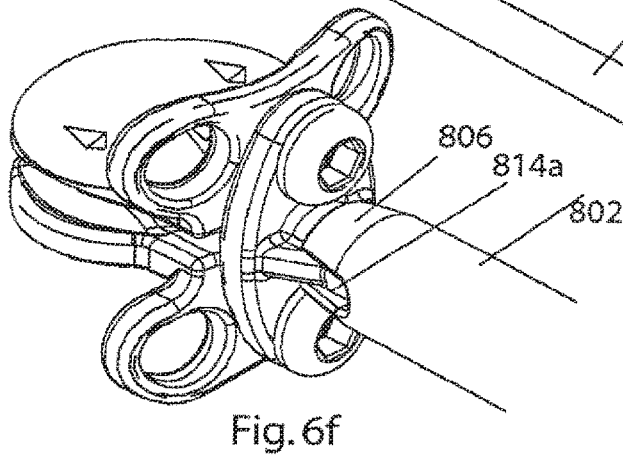
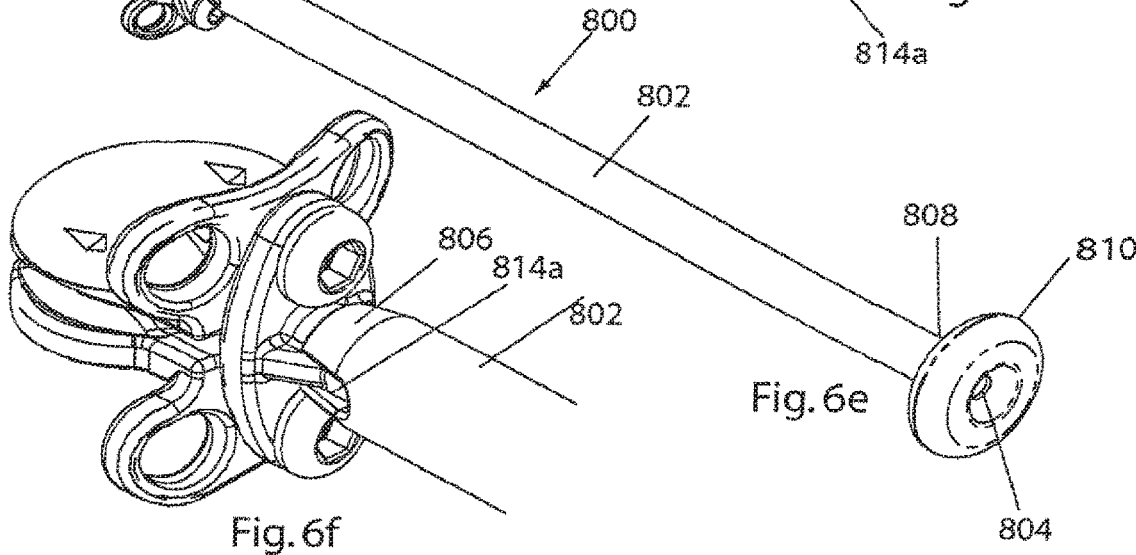
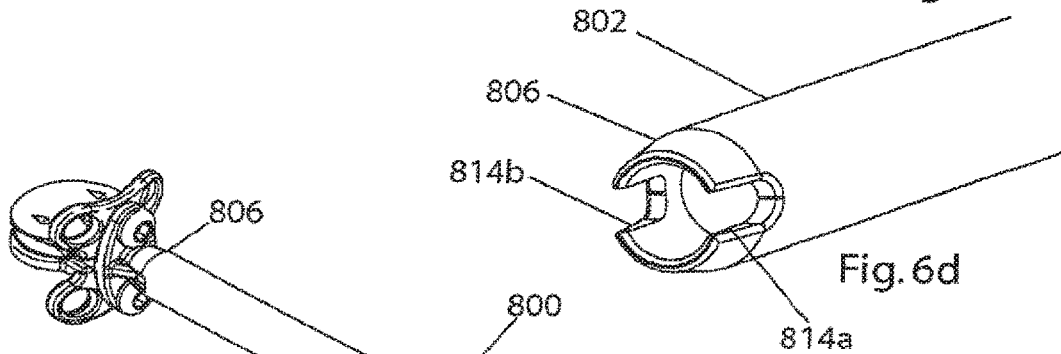
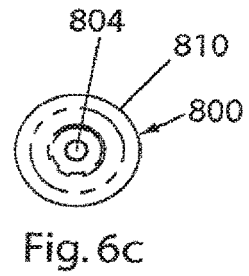
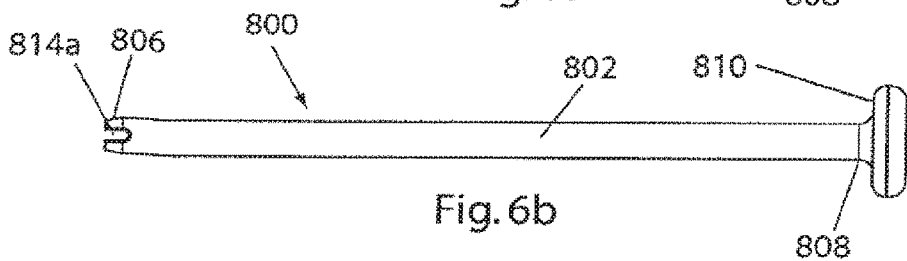
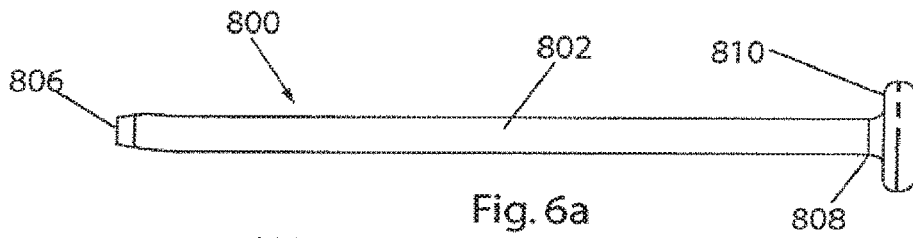
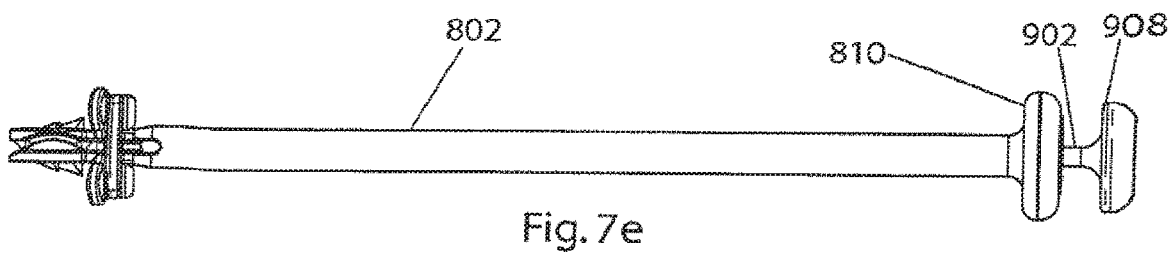
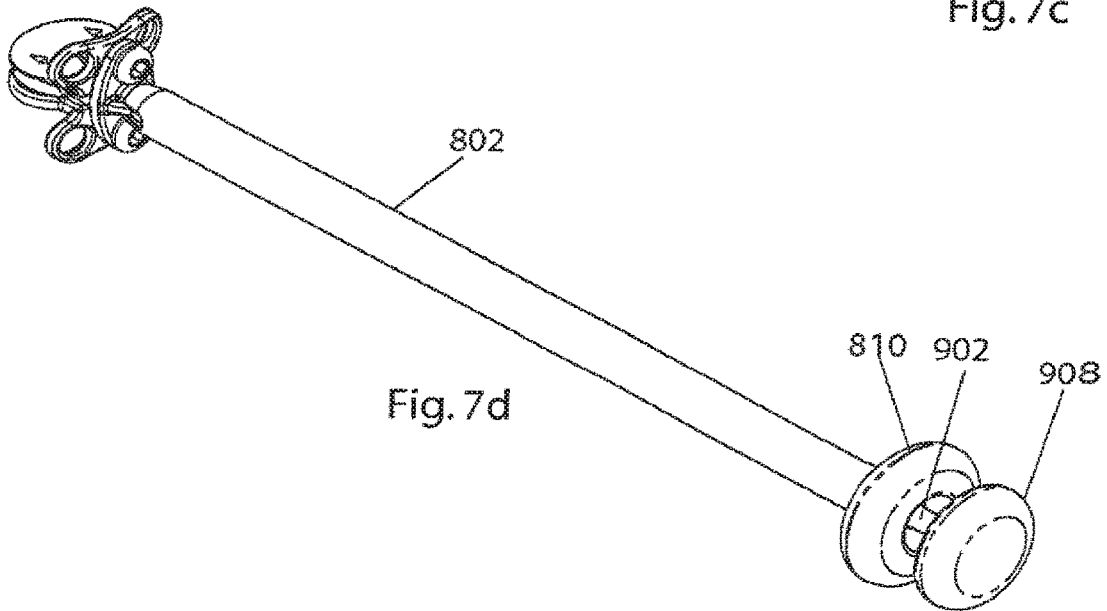
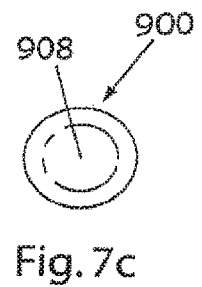
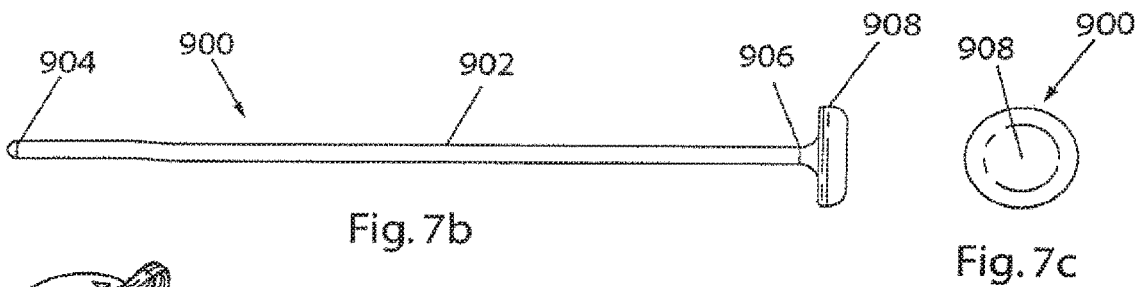
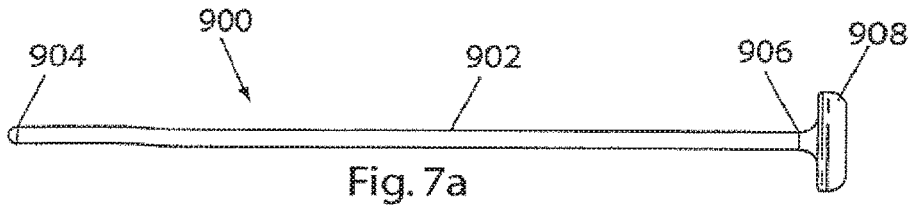

Fig. 3f









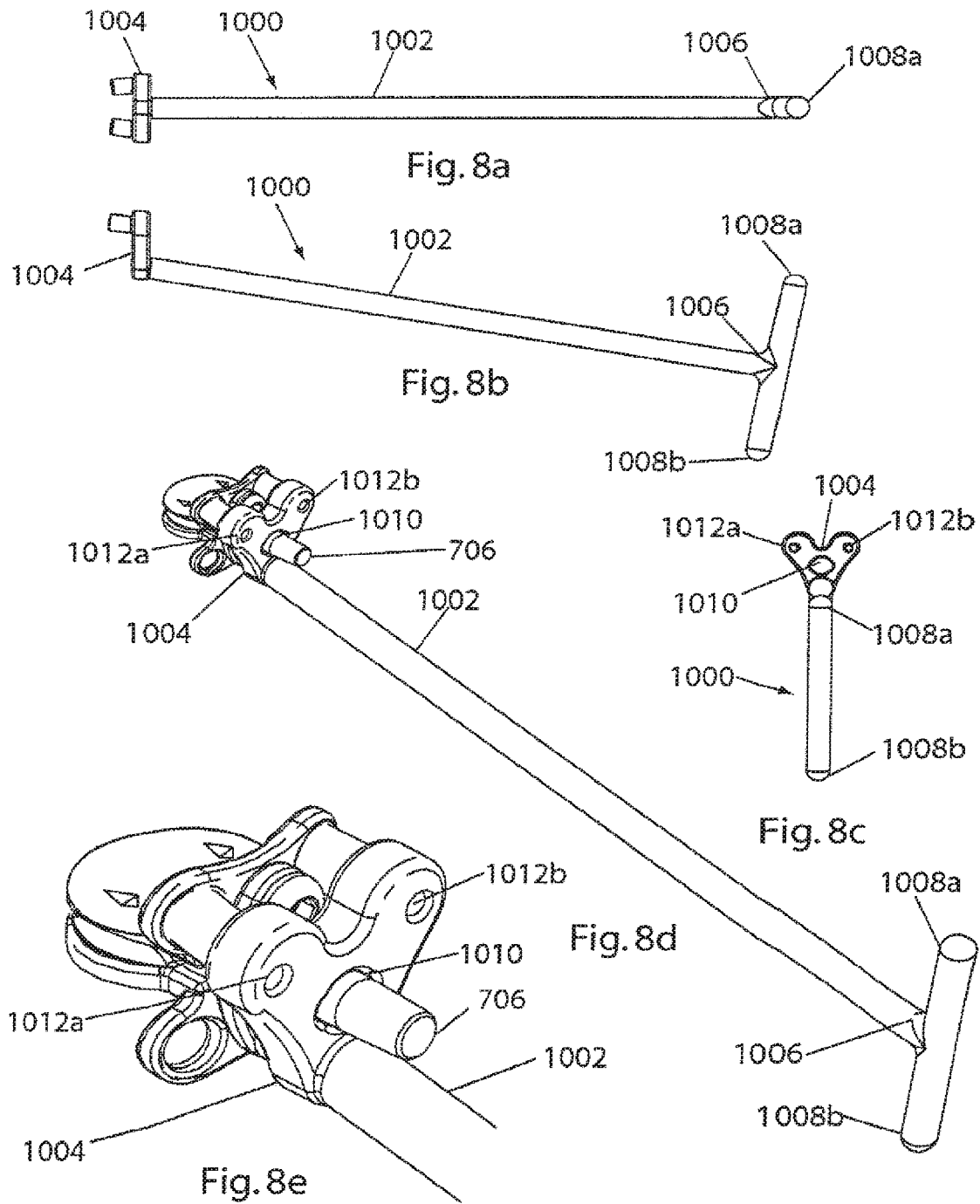

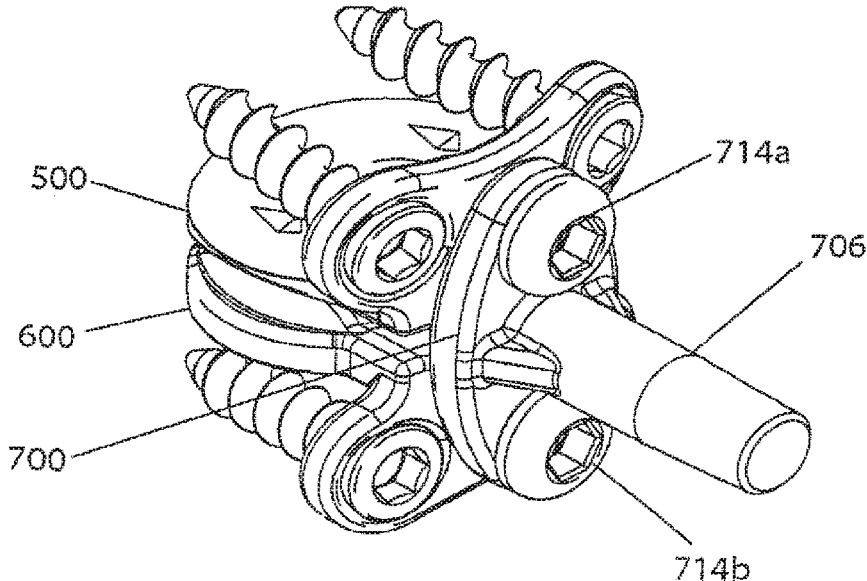

Fig. 9a

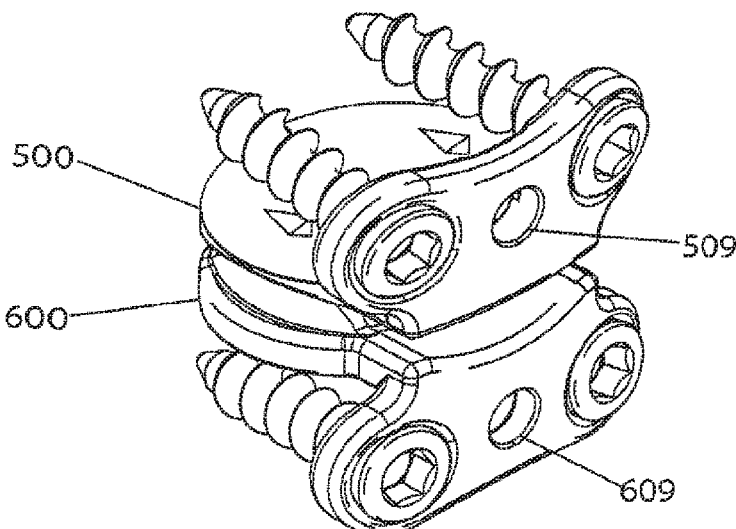

Fig. 9b

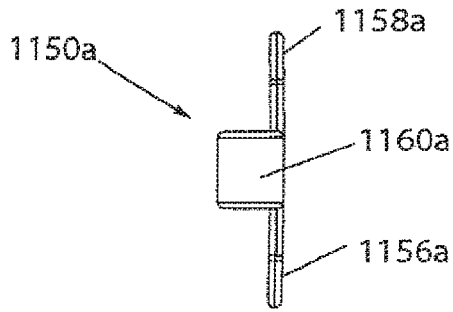

Fig. 10a

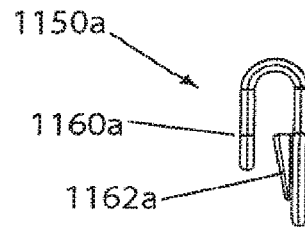

Fig. 10b

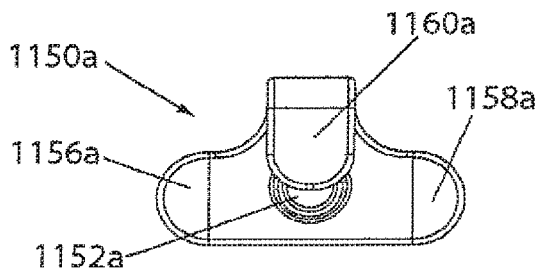

Fig. 10c

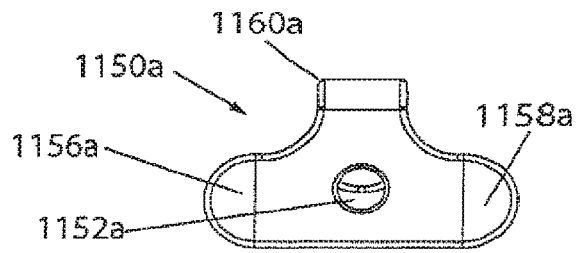

Fig. 10d

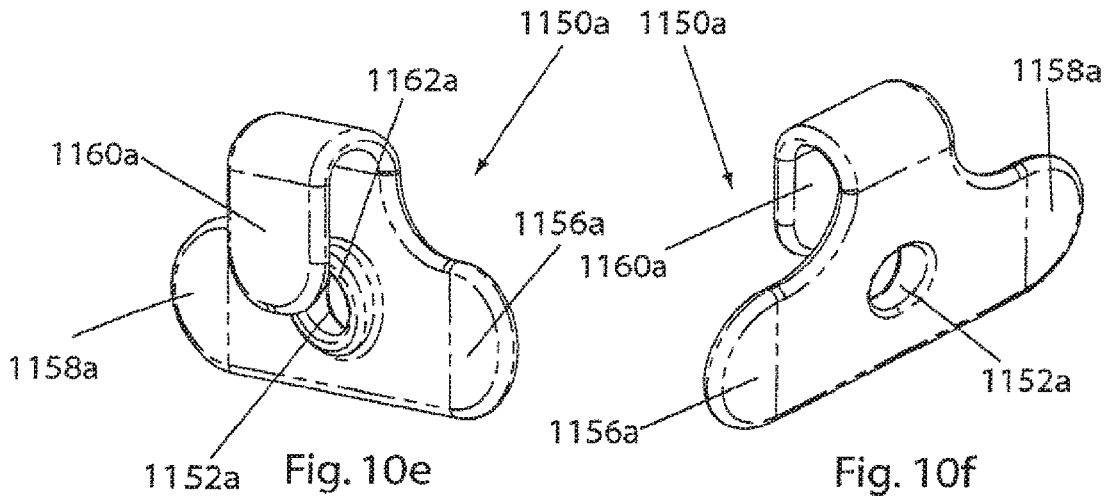

Fig. 10e

Fig. 10f

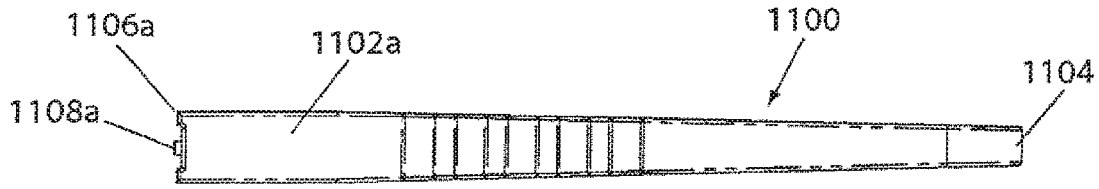

Fig. 11a

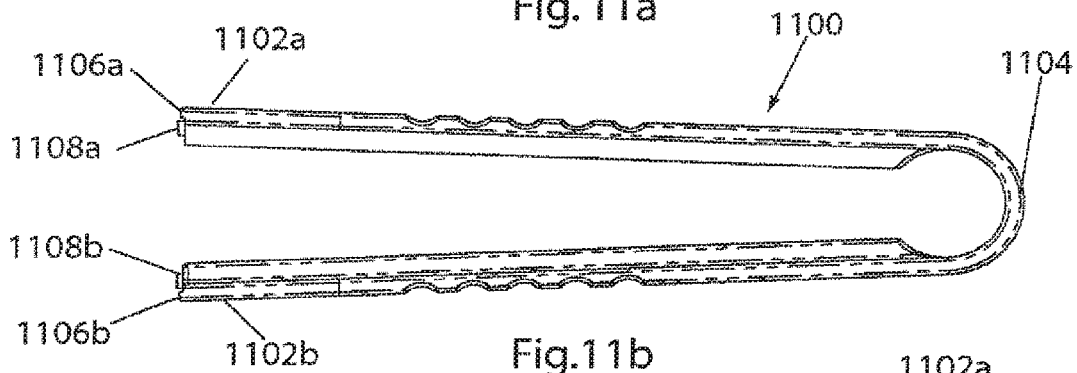

Fig. 11b

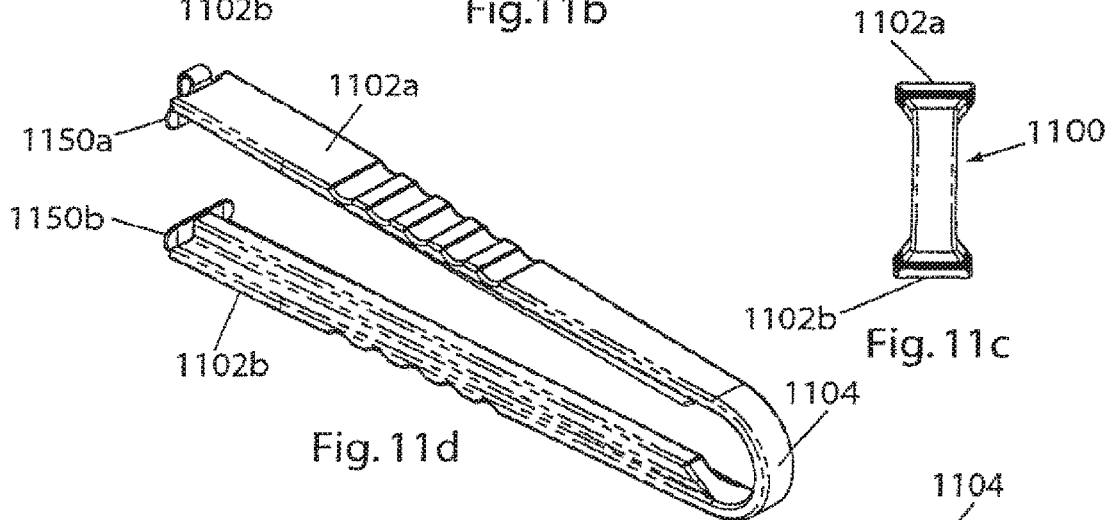

Fig. 11c

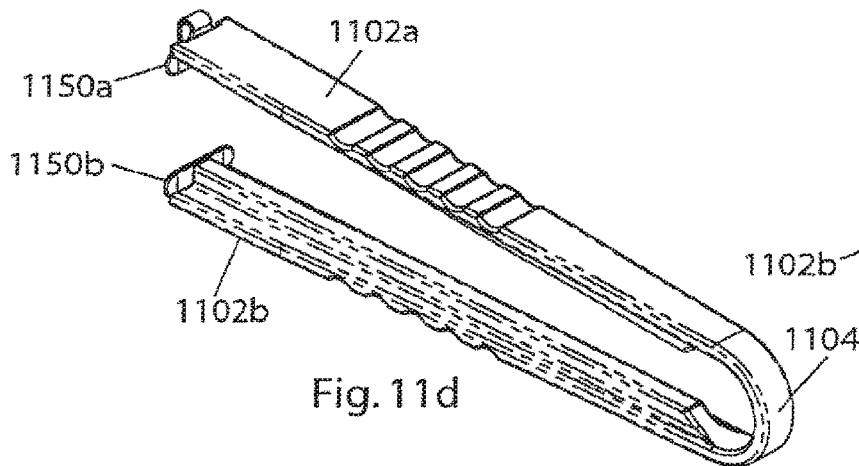

Fig. 11d

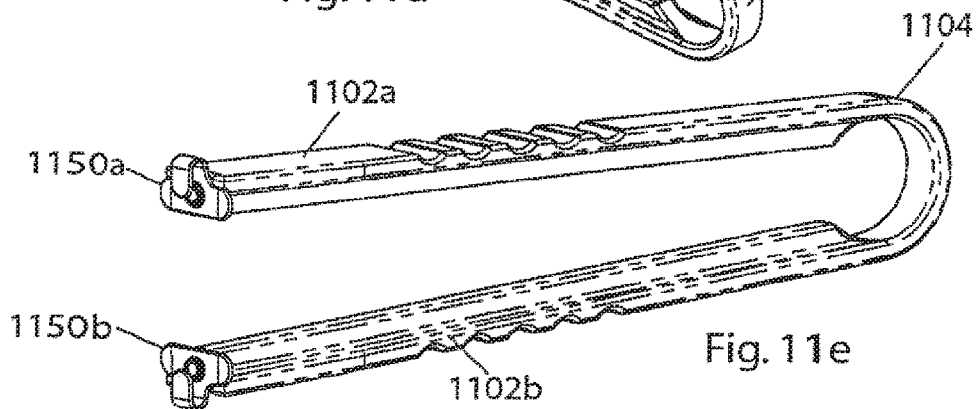
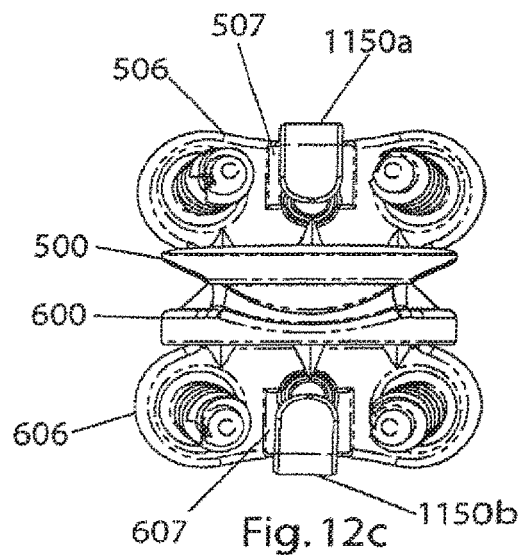
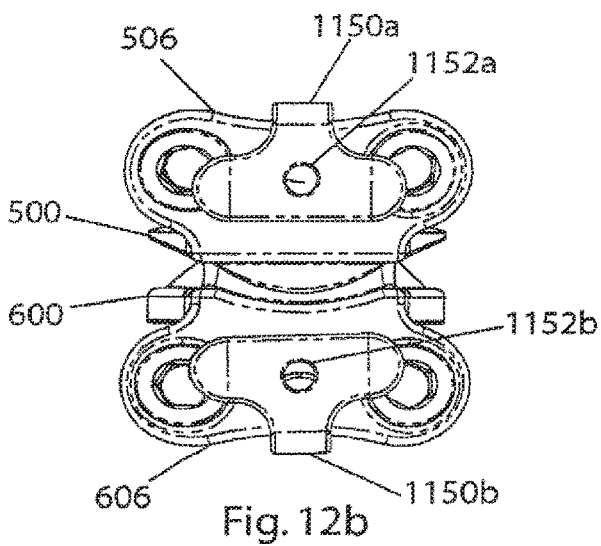
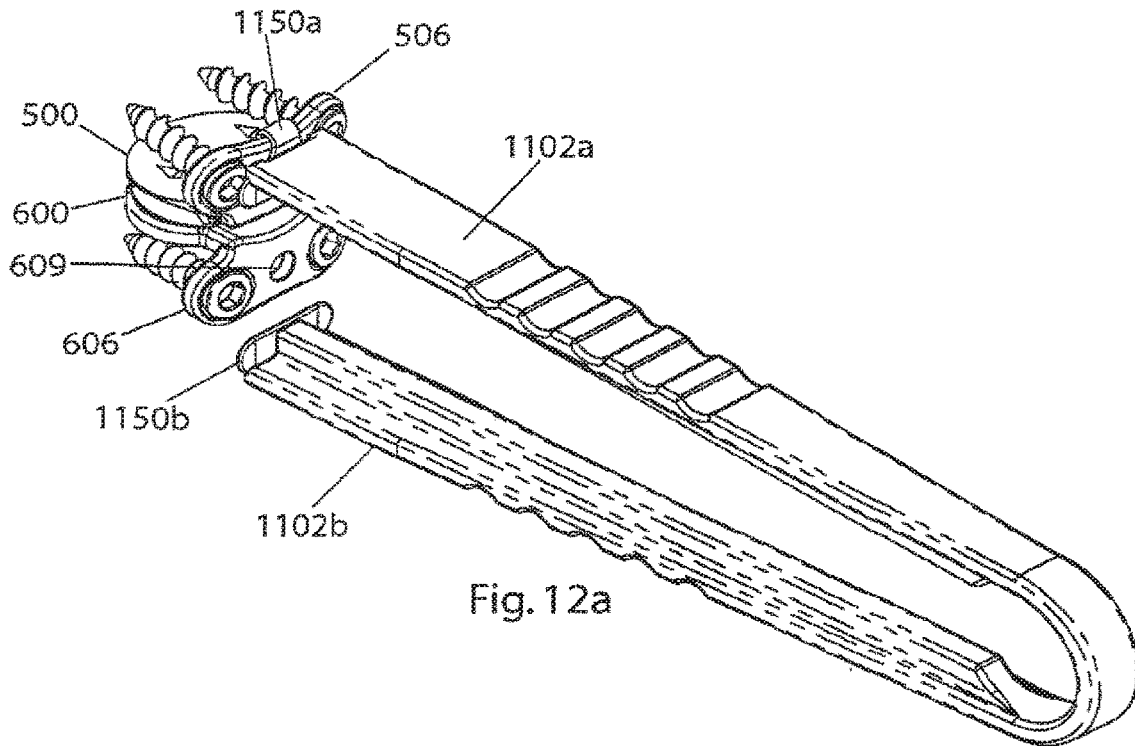

Fig. 11e



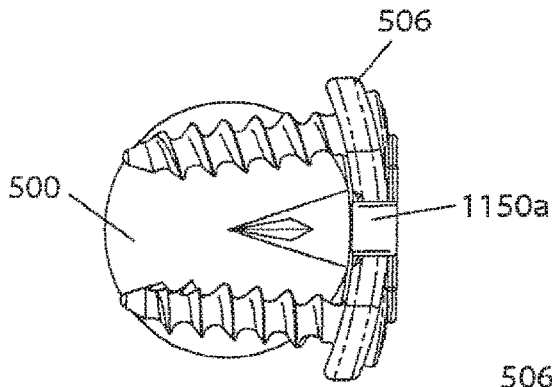

Fig. 12d

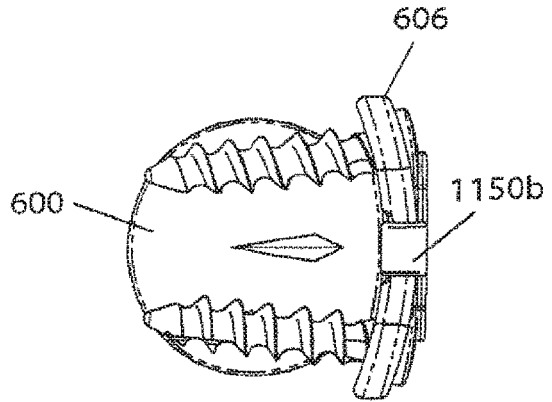

Fig. 12e

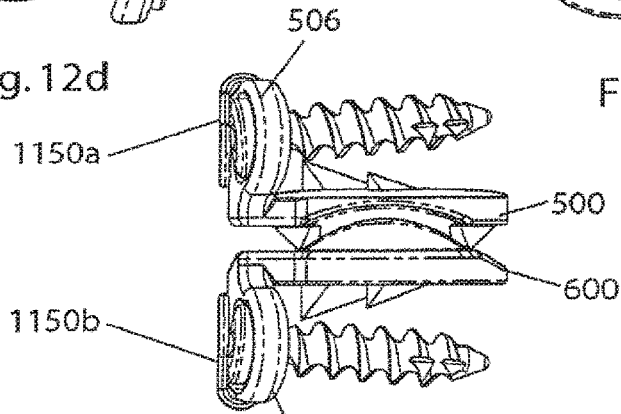

Fig. 12f

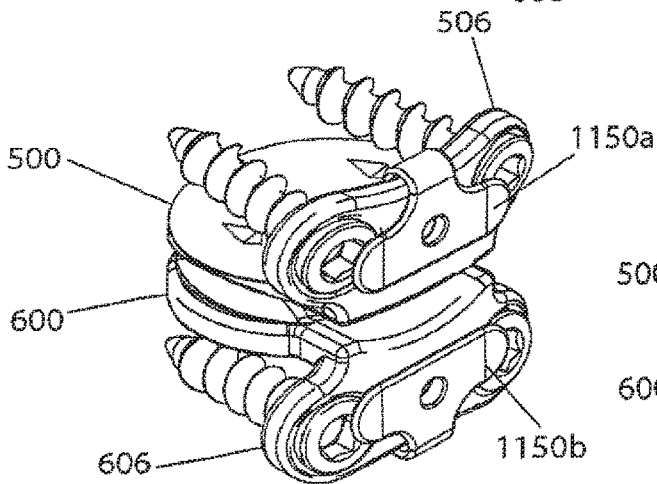

Fig. 12g

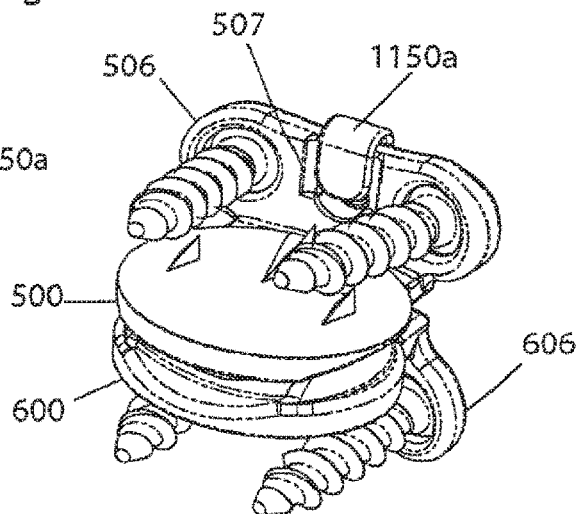

Fig. 12h

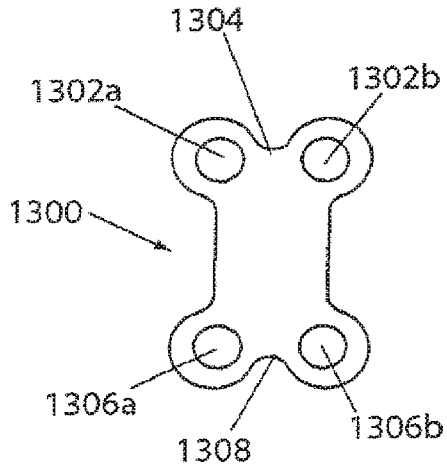

Fig. 13a

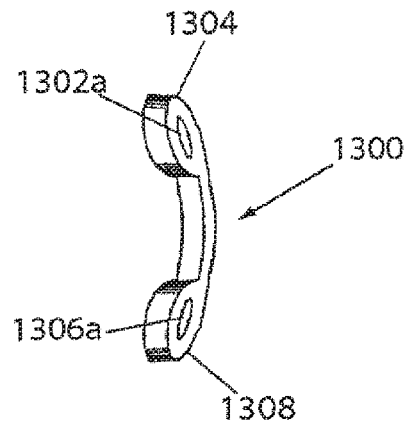

Fig. 13b

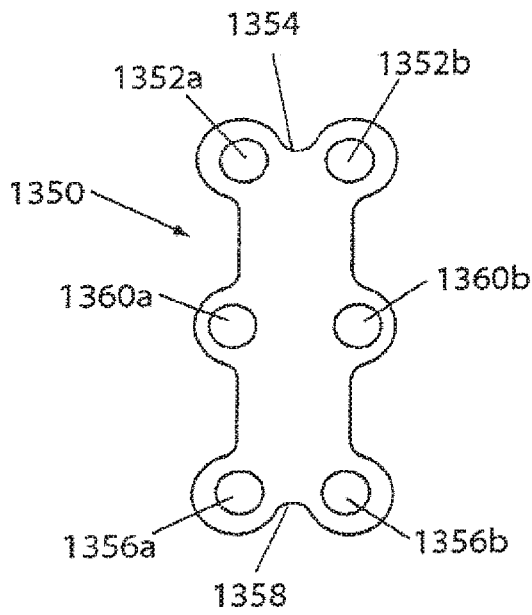

Fig. 13c

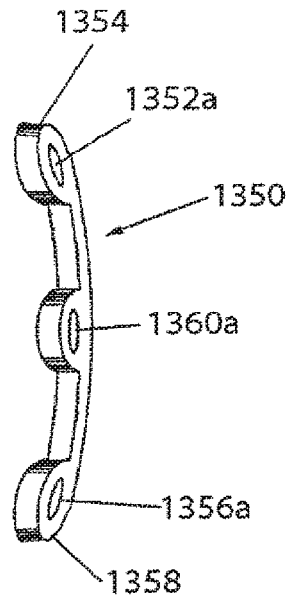

Fig. 13d

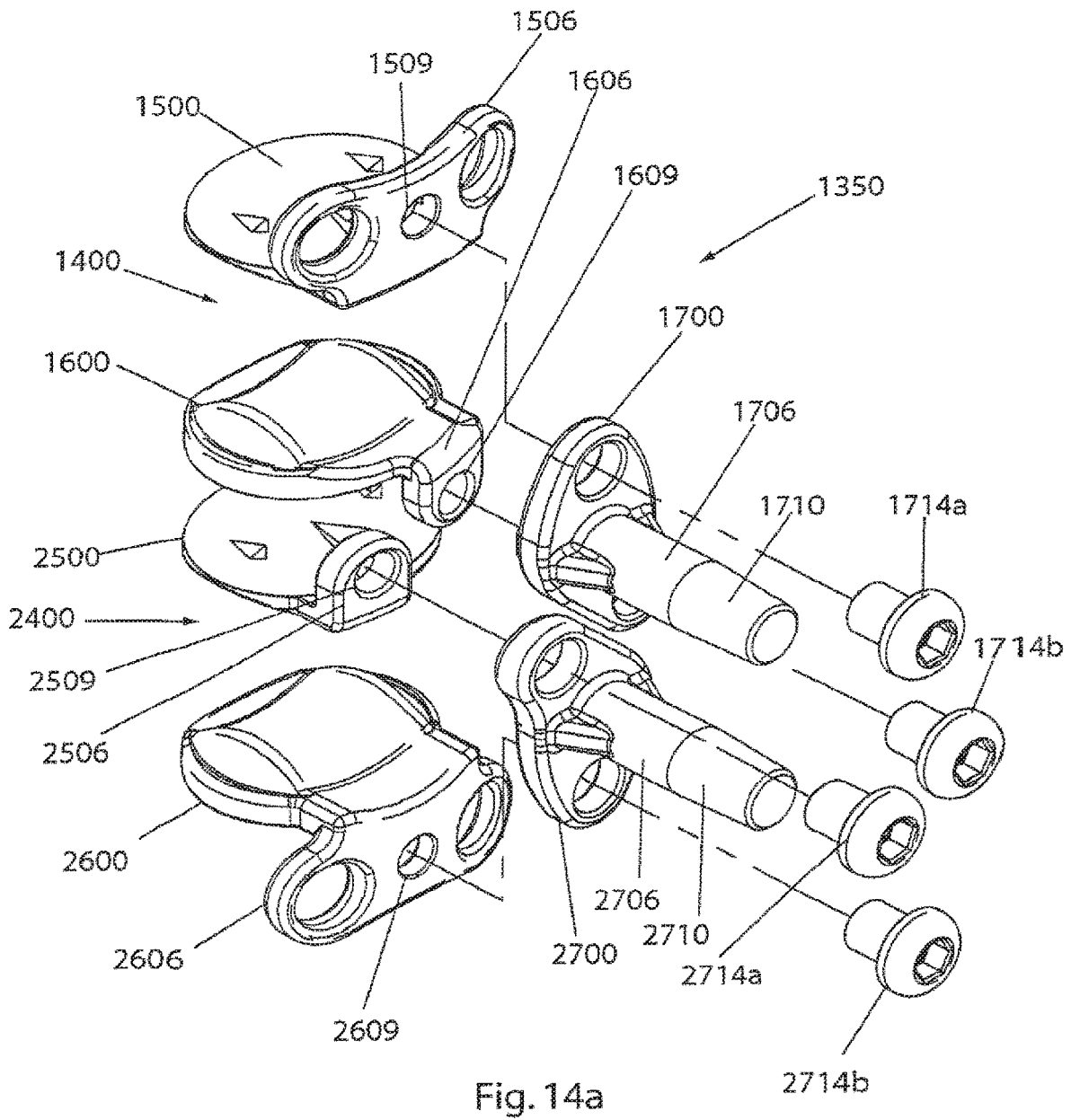

Fig. 14a

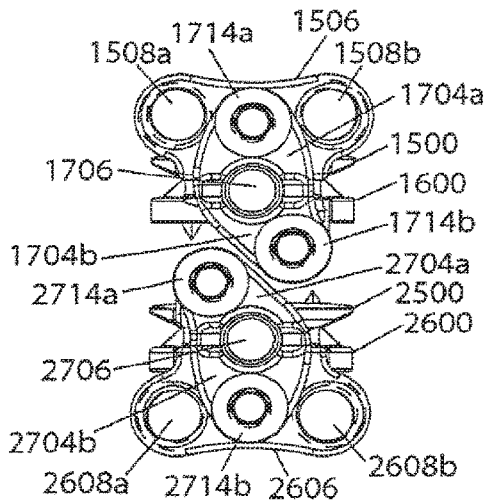

Fig. 14b

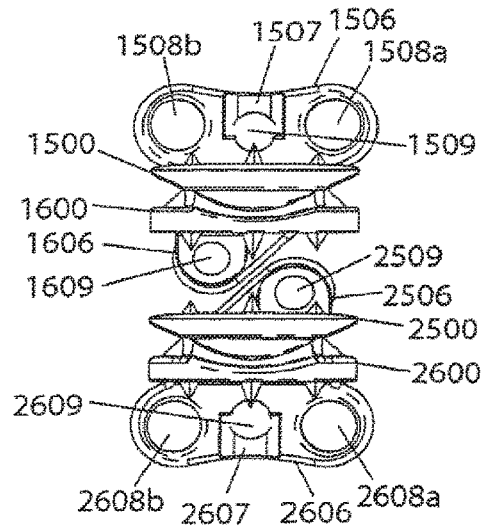

Fig. 14c

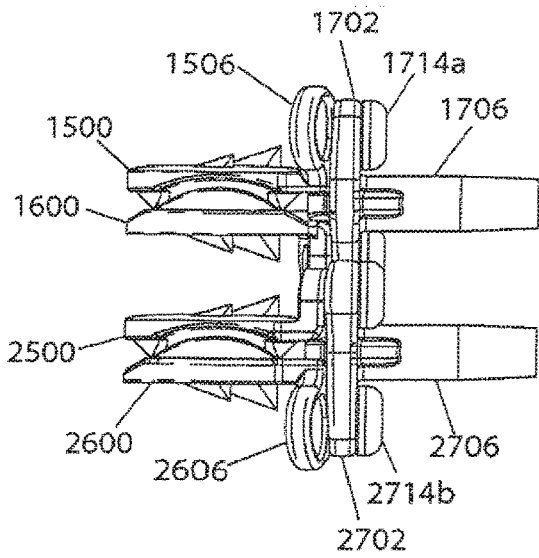

Fig. 14d

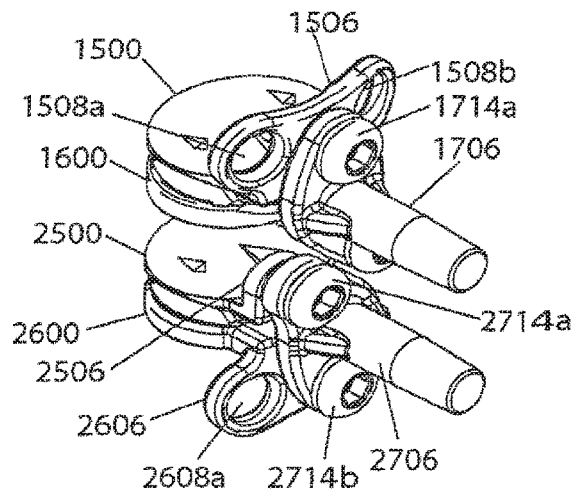
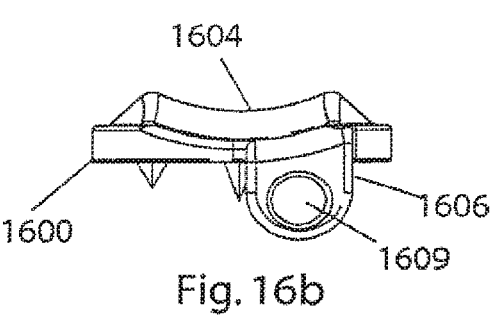
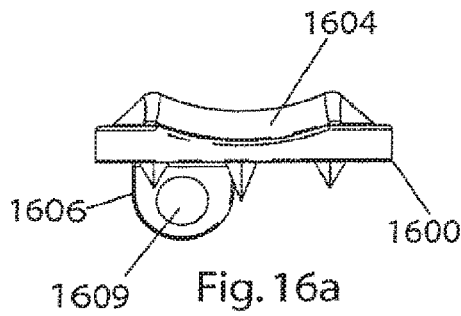
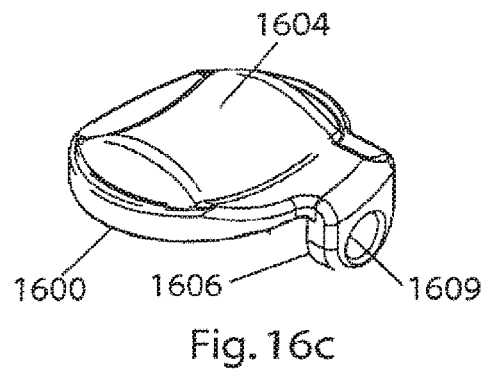
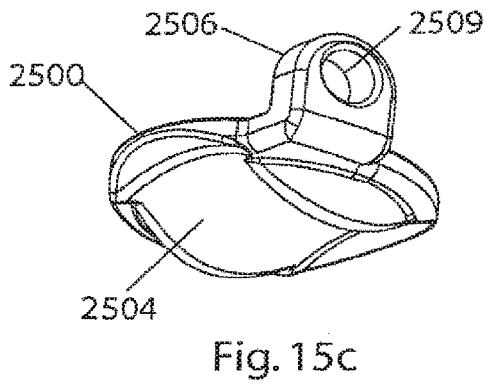
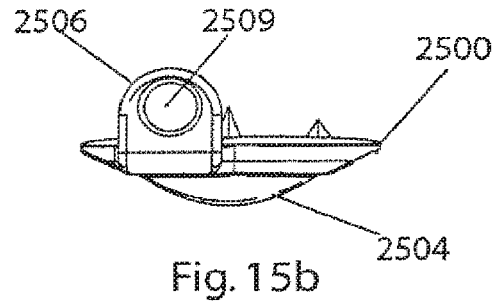
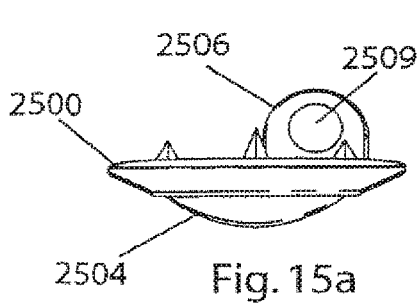

Fig. 14e



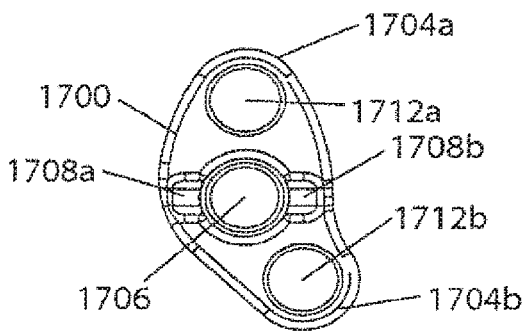

Fig. 17a

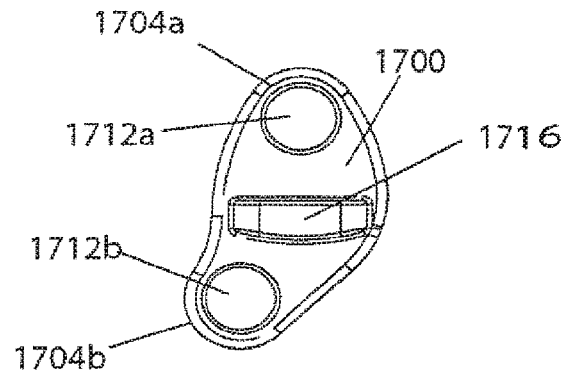

Fig. 17b

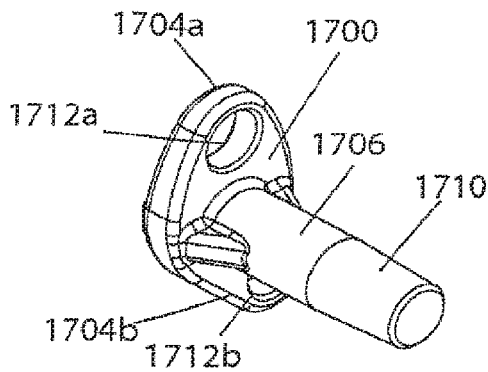

Fig. 17c

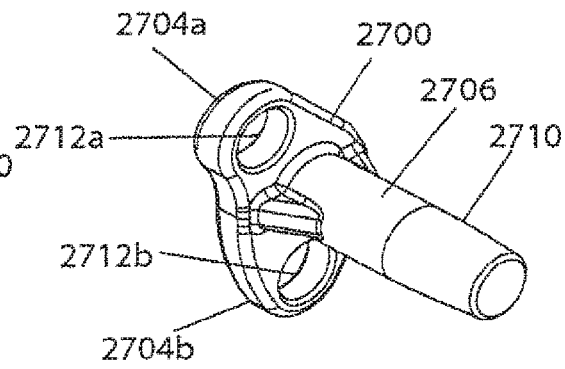

Fig. 18c

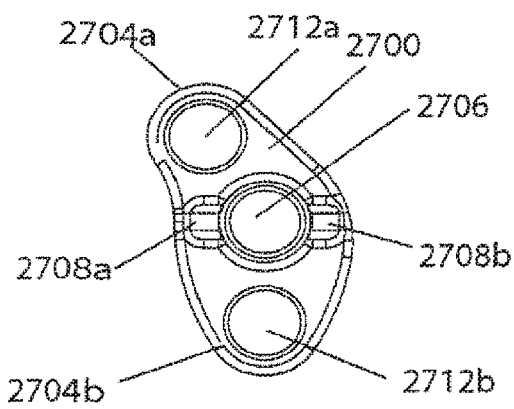

Fig. 18a

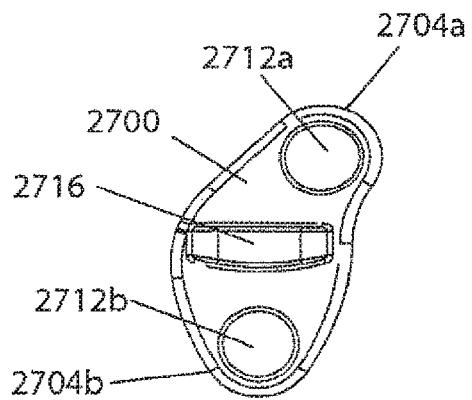

Fig. 18b

INSTRUMENTATION AND METHODS FOR USE IN IMPLANTING A CERVICAL DISC REPLACEMENT DEVICE

CROSS REFERENCE TO RELATED APPLICATIONS

[0001] This application is a continuation of U.S. patent application Ser. No. 16/193,503, filed Nov. 16, 2018, which is a continuation of U.S. patent application Ser. No. 15/434,436, filed Feb. 16, 2017, which is a continuation of U.S. patent application Ser. No. 14/623,151, filed Feb. 16, 2016, which is a continuation of U.S. patent application Ser. No. 13/856,491, filed Apr. 4, 2013, which is a continuation of U.S. application Ser. No. 12/564,554, filed on Sep. 22, 2009, now U.S. Pat. No. 8,435,297, which is a continuation of U.S. application Ser. No. 10/781,484, filed on Feb. 18, 2004, now U.S. Pat. No. 7,618,439, which is a continuation of U.S. application Ser. No. 10/688,632, filed on Oct. 17, 2003, now U.S. Pat. No. 6,896,676, which is a continuation-in-part of U.S. application Ser. No. 10/382,702, filed on Mar. 6, 2003, now U.S. Pat. No. 6,908,484, the disclosures of which are hereby incorporated herein by reference.

FIELD OF THE INVENTION

[0002] This invention relates generally to systems and methods for use in spine arthroplasty, and more specifically to instruments for inserting and removing cervical disc replacement trials, and inserting and securing cervical disc replacement devices, and methods of use thereof.

BACKGROUND OF THE INVENTION

[0003] The structure of the intervertebral disc disposed between the cervical bones in the human spine comprises a peripheral fibrous shroud (the annulus) which circumscribes a spheroid of flexibly deformable material (the nucleus). The nucleus comprises a hydrophilic, elastomeric cartilaginous substance that cushions and supports the separation between the bones while also permitting articulation of the two vertebral bones relative to one another to the extent such articulation is allowed by the other soft tissue and bony structures surrounding the disc. The additional bony structures that define pathways of motion in various modes include the posterior joints (the facets) and the lateral intervertebral joints (the unco-vertebral joints). Soft tissue components, such as ligaments and tendons, constrain the overall segmental motion as well.

[0004] Traumatic, genetic, and long term wearing phenomena contribute to the degeneration of the nucleus in the human spine. This degeneration of this critical disc material, from the hydrated, elastomeric material that supports the separation and flexibility of the vertebral bones, to a flattened and inflexible state, has profound effects on the mobility (instability and limited ranges of appropriate motion) of the segment, and can cause significant pain to the individual suffering from the condition. Although the specific causes of pain in patients suffering from degenerative disc disease of the cervical spine have not been definitively established, it has been recognized that pain may be the result of neurological implications (nerve fibers being compressed) and/or the subsequent degeneration of the surrounding tissues (the arthritic degeneration of the facet joints) as a result of their being overloaded.

[0005] Traditionally, the treatment of choice for physicians caring for patients who suffer from significant degeneration of the cervical intervertebral disc is to remove some, or all, of the damaged disc. In instances in which a sufficient portion of the intervertebral disc material is removed, or in which much of the necessary spacing between the vertebrae has been lost (significant subsidence), restoration of the intervertebral separation is required.

[0006] Unfortunately, until the advent of spine arthroplasty devices, the only methods known to surgeons to maintain the necessary disc height necessitated the immobilization of the segment. Immobilization is generally achieved by attaching metal plates to the anterior or posterior elements of the cervical spine, and the insertion of some osteoconductive material (autograft, allograft, or other porous material) between the adjacent vertebrae of the segment. This immobilization and insertion of osteoconductive material has been utilized in pursuit of a fusion of the bones, which is a procedure carried out on tens of thousands of pain suffering patients per year.

[0007] This sacrifice of mobility at the immobilized, or fused, segment, however, is not without consequences. It was traditionally held that the patient's surrounding joint segments would accommodate any additional articulation demanded of them during normal motion by virtue of the fused segment's immobility. While this is true over the short-term (provided only one, or at most two, segments have been fused), the effects of this increased range of articulation demanded of these adjacent segments has recently become a concern. Specifically, an increase in the frequency of returning patients who suffer from degeneration at adjacent levels has been reported.

[0008] Whether this increase in adjacent level deterioration is truly associated with rigid fusion, or if it is simply a matter of the individual patient's predisposition to degeneration is unknown. Either way, however, it is clear that a progressive fusion of a long sequence of vertebrae is undesirable from the perspective of the patient's quality of life as well as from the perspective of pushing a patient to undergo multiple operative procedures.

[0009] While spine arthroplasty has been developing in theory over the past several decades, and has even seen a number of early attempts in the lumbar spine show promising results, it is only recently that arthroplasty of the spine has become a truly realizable promise. The field of spine arthroplasty has several classes of devices. The most popular among these are: (a) the nucleus replacements, which are characterized by a flexible container filled with an elastomeric material that can mimic the healthy nucleus; and (b) the total disc replacements, which are designed with rigid endplates which house a mechanical articulating structure that attempts to mimic and promote the healthy segmental motion.

[0010] Among these solutions, the total disc replacements have begun to be regarded as the most probable long-term treatments for patients having moderate to severe lumbar disc degeneration. In the cervical spine, it is likely that these mechanical solutions will also become the treatment of choice.

[0011] It is an object of the invention to provide instrumentation and methods that enable surgeons to more accurately, easily, and efficiently implant fusion or non-fusion cervical disc replacement devices. Other objects of the invention not explicitly stated will be set forth and will be

more clearly understood in conjunction with the descriptions of the preferred embodiments disclosed hereafter.

SUMMARY OF THE INVENTION

[0012] The preceding objects are achieved by the invention, which includes cervical disc replacement trials, cervical disc replacement devices, cervical disc replacement device insertion instrumentation (including, e.g., an insertion plate with mounting screws, an insertion handle, and an insertion pusher), and cervical disc replacement device fixation instrumentation (including, e.g., drill guides, drill bits, screwdrivers, bone screws, and retaining clips).

[0013] More particularly, the devices, instrumentation, and methods disclosed herein are intended for use in spine arthroplasty procedures, and specifically for use with the devices, instrumentation, and methods described herein in conjunction with the devices, instrumentation, and methods described herein and in the '702 application. However, it should be understood that the devices, instrumentation, and methods described herein are also suitable for use with other intervertebral disc replacement devices, instrumentation, and methods without departing from the scope of the invention.

[0014] For example, while the trials described herein are primarily intended for use in distracting an intervertebral space and/or determining the appropriate size of cervical disc replacement devices (e.g., described herein and in the '702 application) to be implanted (or whether a particular size can be implanted) into the distracted intervertebral space, they can also be used for determining the appropriate size of any other suitably configured orthopedic implant or trial to be implanted (or whether a particular size can be implanted) into the distracted intervertebral space. And, for example, while the insertion instrumentation described herein is primarily intended for use in holding, inserting, and otherwise manipulating cervical disc replacement devices (e.g., described herein and, in suitably configured embodiments, in the '702 application), it can also be used for manipulating any other suitably configured orthopedic implant or trial. And, for example, while the fixation instrumentation described herein is primarily intended for use in securing within the intervertebral space the cervical disc replacement devices (e.g., described herein and, in suitably configured embodiments, in the '702 application), it can also be used with any other suitably configured orthopedic implant or trial.

[0015] While the instrumentation described herein (e.g., the trials, insertion instrumentation, and fixation instrumentation) will be discussed for use with the cervical disc replacement device of FIGS. 1a-3f herein, such discussions are merely by way of example and not intended to be limiting of their uses. Thus, it should be understood that the tools can be used with suitably configured embodiments of the cervical disc replacement devices disclosed in the '702 application, or any other artificial intervertebral disc having (or being modifiable or modified to have) suitable features therefor. Moreover, it is anticipated that the features of the cervical disc replacement device (e.g., the flanges, bone screw holes, and mounting holes) that are used by the tools discussed herein to hold and/or manipulate these devices (some of such features, it should be noted, were first shown and disclosed in the '702 application) can be applied, individually or collectively or in various combinations, to other trials, spacers, artificial intervertebral discs, or other

orthopedic devices as stand-alone innovative features for enabling such trials, spacers, artificial intervertebral discs, or other orthopedic devices to be more efficiently and more effectively held and/or manipulated by the tools described herein or by other tools having suitable features. In addition, it should be understood that the invention encompasses artificial intervertebral discs, spacers, trials, and/or other orthopedic devices, that have one or more of the features disclosed herein, in any combination, and that the invention is therefore not limited to artificial intervertebral discs, spacers, trials, and/or other orthopedic devices having all of the features simultaneously.

[0016] The cervical disc replacement device of FIGS. 1a-3f is an alternate embodiment of the cervical disc replacement device of the '702 application. The illustrated alternate embodiment of the cervical disc replacement device is identical in structure to the cervical disc replacement device in the '702 application, with the exception that the vertebral bone attachment flanges are configured differently, such that they are suitable for engagement by the instrumentation described herein.

[0017] More particularly, in this alternate embodiment, the flange of the upper element extends upwardly from the anterior edge of the upper element, and has a lateral curvature that approximates the curvature of the anterior periphery of the upper vertebral body against which it is to be secured. The attachment flange is provided with a flat recess, centered on the midline, that accommodates a clip of the present invention. The attachment flange is further provided with two bone screw holes symmetrically disposed on either side of the midline. The holes have longitudinal axes directed along preferred bone screw driving lines. Centrally between the bone screw holes, a mounting screw hole is provided for attaching the upper element to an insertion plate of the present invention for implantation. The lower element is similarly configured with a similar oppositely extending flange.

[0018] Once the surgeon has prepared the intervertebral space, the surgeon may use one or more cervical disc replacement trials of the present invention to distract the intervertebral space and determine the appropriate size of a cervical disc replacement device to be implanted (or whether a particular size of the cervical disc replacement device can be implanted) into the distracted cervical intervertebral space. Preferably, for each cervical disc replacement device to be implanted, a plurality of sizes of the cervical disc replacement device would be available. Accordingly, preferably, each of the plurality of trials for use with a particular plurality of differently sized cervical disc replacement devices would have a respective oval footprint and depth dimension set corresponding to the footprint and depth dimension set of a respective one of the plurality of differently sized cervical disc replacement devices.

[0019] Each of the cervical disc replacement trials includes a distal end configured to approximate relevant dimensions of an available cervical disc replacement device. The distal end has a head with an oval footprint. The upper surface of the head is convex, similar to the configuration of the vertebral body contact surface of the upper element of the cervical disc replacement device (but without the teeth). The lower surface of the head is flat, similar to the configuration of the vertebral body contact surface of the lower element of the cervical disc replacement device (but without the teeth). The cervical disc replacement trial, not having the

teeth, can be inserted and removed from the intervertebral space without compromising the endplate surfaces. The cervical disc replacement trial further has a vertebral body stop disposed at the anterior edge of the head, to engage the anterior surface of the upper vertebral body before the trial is inserted too far into the intervertebral space.

[0020] Accordingly, the surgeon can insert and remove at least one of the trials (or more, as necessary) from the prepared intervertebral space. As noted above, the trials are useful for distracting the prepared intervertebral space. For example, starting with the largest distractor that can be wedged in between the vertebral bones, the surgeon will insert the trial head and then lever the trial handle up and down to loosen the annulus and surrounding ligaments to urge the bone farther apart. The surgeon then removes the trial head from the intervertebral space, and replaces it with the next largest (in terms of height) trial head. The surgeon then levers the trial handle up and down to further loosen the annulus and ligaments. The surgeon then proceeds to remove and replace the trial head with the next largest (in terms of height) trial head, and continues in this manner with larger and larger trials until the intervertebral space is distracted to the appropriate height.

[0021] Regardless of the distraction method used, the cervical disc replacement trials are useful for finding the cervical disc replacement device size that is most appropriate for the prepared intervertebral space, because each of the trial heads approximates the relevant dimensions of an available cervical disc replacement device. Once the intervertebral space is distracted, the surgeon can insert and remove one or more of the trial heads to determine the appropriate size of cervical disc replacement device to use. Once the appropriate size is determined, the surgeon proceeds to implant the selected cervical disc replacement device.

[0022] An insertion plate of the present invention is mounted to the cervical disc replacement device to facilitate a preferred simultaneous implantation of the upper and lower elements of the replacement device. The upper and lower elements are held by the insertion plate in an aligned configuration preferable for implantation. A ledge on the plate maintains a separation between the anterior portions of the inwardly facing surfaces of the elements to help establish and maintain this preferred relationship. The flanges of the elements each have a mounting screw hole and the insertion plate has two corresponding mounting holes. Mounting screws are secured through the colinear mounting screw hole pairs, such that the elements are immovable with respect to the insertion plate and with respect to one another. In this configuration, the upper element, lower element, and insertion plate construct is manipulatable as a single unit.

[0023] An insertion handle of the present invention is provided primarily for engaging an anteriorly extending stem of the insertion plate so that the cervical disc replacement device and insertion plate construct can be manipulated into and within the treatment site. The insertion handle has a shaft with a longitudinal bore at a distal end and a flange at a proximal end. Longitudinally aligning the insertion handle shaft with the stem, and thereafter pushing the hollow distal end of the insertion handle shaft toward the insertion plate, causes the hollow distal end to friction-lock to the outer surface of the stem. Once the insertion handle is engaged with the insertion plate, manipulation of the insertion handle shaft effects manipulation of the cervical disc

replacement device and insertion plate construct. The surgeon can therefore insert the construct into the treatment area. More particularly, after the surgeon properly prepares the intervertebral space, the surgeon inserts the cervical disc replacement device into the intervertebral space from an anterior approach, such that the upper and lower elements are inserted between the adjacent vertebral bones with the element footprints fitting within the perimeter of the intervertebral space and with the teeth of the elements' vertebral body contact surfaces engaging the vertebral endplates, and with the flanges of the upper and lower elements flush against the anterior faces of the upper and lower vertebral bones, respectively.

[0024] Once the construct is properly positioned in the treatment area, the surgeon uses an insertion pusher of the present invention to disengage the insertion handle shaft from the stem of the insertion plate. The insertion pusher has a longitudinal shaft with a blunt distal end and a proximal end with a flange. The shaft of the insertion pusher can be inserted into and translated within the longitudinal bore of the insertion handle shaft. Because the shaft of the insertion pusher is as long as the longitudinal bore of the insertion handle shaft, the flange of the insertion handle and the flange of the insertion pusher are separated by a distance when the pusher shaft is inserted all the way into the longitudinal bore until the blunt distal end of the shaft contacts the proximal face of the insertion plate stem. Accordingly, a bringing together of the flanges (e.g., by the surgeon squeezing the flanges toward one another) will overcome the friction lock between the distal end of the insertion handle shaft and the stem of the insertion plate.

[0025] Once the insertion handle has been removed, the surgeon uses a drill guide of the present invention to guide the surgeon's drilling of bone screws through the bone screw holes of the upper and lower elements' flanges and into the vertebral bones. The drill guide has a longitudinal shaft with a distal end configured with a central bore that accommodates the stem so that the drill guide can be placed on and aligned with the stem. The distal end is further configured to have two guide bores that have respective longitudinal axes at preferred bone screw drilling paths relative to one another. When the central bore is disposed on the stem of the insertion plate, the drill guide shaft can be rotated on the stem into either of two preferred positions in which the guide bores are aligned with the bone screw holes on one of the flanges, or with the bone screw holes on the other flange.

[0026] To secure the upper element flange to the upper vertebral body, the surgeon places the drill guide shaft onto the stem of the insertion plate, and rotates the drill guide into the first preferred position. Using a suitable bone drill and cooperating drill bit, the surgeon drills upper tap holes for the upper bone screws. The surgeon then rotates the drill guide shaft on the stem of the insertion plate until the guide bores no longer cover the upper bone screw holes. The surgeon can then screw the upper bone screws into the upper tap holes using a suitable surgical bone screw driver. To then secure the lower element flange to the lower vertebral body, the surgeon further rotates the drill guide shaft on the stem of the insertion plate until the drill guide is in the second preferred position, and proceeds to drill the lower bone screw tap holes and screw the lower bone screws into them in the same manner.

[0027] Once the upper and lower elements are secured to the adjacent vertebral bones, the surgeon removes the drill

guide from the stem of the insertion plate and from the treatment area. Using a suitable surgical screw driver, the surgeon then removes the mounting screws that hold the insertion plate against the elements' flanges and removes the insertion plate and the mounting screws from the treatment area.

[0028] Once the mounting screws and the insertion plate are removed, the surgeon uses a clip applicator of the present invention to mount retaining clips on the flanges to assist in retaining the bone screws. Each of the clips has a central attachment bore and, extending therefrom, a pair of oppositely directed laterally extending flanges and an upwardly (or downwardly) extending hooked flange. The clips can be snapped onto the element flanges (one clip onto each flange). Each of the laterally extending flanges of the clip is sized to cover at least a portion of a respective one of the bone screw heads when the clip is attached in this manner to the flange so that the clips help prevent the bone screws from backing out.

[0029] Also disclosed is an alternate dual cervical disc replacement device configuration suitable, for example, for implantation into two adjacent cervical intervertebral spaces. The configuration includes an alternate, upper, cervical disc replacement device (including an upper element and an alternate lower element), for implantation into an upper cervical intervertebral space, and further includes an alternate, lower, cervical disc replacement device (including an alternate upper element and a lower element), for implantation into an adjacent, lower, cervical intervertebral space. The illustrated alternate, upper, embodiment is identical in structure to the cervical disc replacement device of FIGS. 1a-3f, with the exception that the flange of the lower element is configured differently and without bone screw holes. The illustrated alternate, lower, embodiment is identical in structure to the cervical disc replacement device of FIGS. 1a-3f, with the exception that the flange of the upper element is configured differently and without bone screw holes.

[0030] More particularly, in the alternate, upper, cervical disc replacement device of this alternate configuration, the flange of the alternate lower element does not have bone screw holes, but does have a mounting screw hole for attaching the alternate lower element to an alternate, upper, insertion plate. Similarly, in the alternate, lower, cervical disc replacement device of this alternate configuration, the flange of the alternate upper element does not have bone screw holes, but does have a mounting screw hole for attaching the alternate upper element to an alternate, lower, insertion plate. The extent of the flange of the alternate lower element is laterally offset to the right (in an anterior view) from the midline, and the extent of the flange of the alternate upper element is laterally offset to the left (in an anterior view) from the midline, so that the flanges avoid one another when the alternate lower element of the alternate, upper, cervical disc replacement device, and the alternate upper element of the alternate, lower, cervical disc replacement device, are implanted in this alternate configuration.

[0031] The alternate, upper, insertion plate is identical in structure to the insertion plate described above, with the exception that the lower flange is offset from the midline (to the right in an anterior view) to align its mounting screw hole with the offset mounting screw hole of the alternate lower element. Similarly, the alternate, lower, insertion plate is identical in structure to the insertion plate described above, with the exception that the upper flange is offset from

the midline (to the left in an anterior view) to align its mounting screw hole with the offset mounting screw hole of the alternate upper element.

[0032] Accordingly, the upper and lower elements of the alternate, upper, cervical disc replacement device, being held by the alternate upper insertion plate, as well as the upper and lower elements of the alternate, lower, cervical disc replacement device, being held by the alternate lower insertion plate, can be implanted using the insertion handle, insertion pusher, drill guide, clips (one on the uppermost element flange, and one on the lowermost element flange, because only the uppermost element and the lowermost element are secured by bone screws), and clip applicator, in the manner described above with respect to the implantation of the cervical disc replacement device.

BRIEF DESCRIPTION OF THE DRAWINGS

[0033] FIGS. 1a-c show anterior (FIG. 1a), lateral (FIG. 1b), and bottom (FIG. 1c) views of a top element of a cervical disc replacement device of the invention.

[0034] FIGS. 2a-c show anterior (FIG. 2a), lateral (FIG. 2b), and top (FIG. 2c) views of a bottom element of the cervical disc replacement device.

[0035] FIG. 3a-f show top (FIG. 3a), lateral (FIG. 3b), anterior (FIG. 3c), posterior (FIG. 3d), antero-lateral perspective (FIG. 3e), and postero-lateral perspective (FIG. 3f) views of the cervical disc replacement device, assembled with the top and bottom elements of FIGS. 1a-c and 2a-c.

[0036] FIGS. 4a-g show top (FIG. 4a), lateral (FIG. 4b), anterior (FIG. 4c), posterior (FIG. 4d), antero-lateral perspective (head only) (FIG. 4e), and postero-lateral perspective (head only) (FIG. 4f) views of a cervical disc replacement device of the present invention.

[0037] FIGS. 5a-d show top (FIG. 5a), lateral (FIG. 5b), anterior (FIG. 5c), and posterior (FIG. 5d) views of an insertion plate of the insertion instrumentation of the present invention. FIGS. 5e and 5f show anterior (FIG. 5e) and antero-lateral perspective (FIG. 5f) views of the insertion plate mounted to the cervical disc replacement device.

[0038] FIGS. 6a-d show top (FIG. 6a), lateral (FIG. 6b), anterior (FIG. 6c), and postero-lateral (FIG. 6d) views of an insertion handle of the insertion instrumentation of the present invention. FIG. 6e shows an antero-lateral perspective view of the insertion handle attached to the insertion plate. FIG. 6f shows a magnified view of the distal end of FIG. 6e.

[0039] FIGS. 7a-c show top (FIG. 7a), lateral (FIG. 7b), and anterior (FIG. 7c) views of an insertion pusher of the insertion instrumentation of the present invention. FIG. 7d shows an antero-lateral perspective view of the insertion pusher inserted into the insertion handle. FIG. 7e shows a magnified view of the proximal end of FIG. 7d.

[0040] FIGS. 8a-c show top (FIG. 8a), lateral (FIG. 8b), and anterior (FIG. 8c) views of a drill guide of the insertion instrumentation of the present invention. FIG. 8d shows an antero-lateral perspective view of the drill guide inserted onto the insertion plate. FIG. 8e shows a magnified view of the distal end of FIG. 8d.

[0041] FIG. 9a shows an antero-lateral perspective view of the cervical disc replacement device implantation after bone screws have been applied and before the insertion plate has been removed. FIG. 9b shows an antero-lateral perspec-

tive view of the cervical disc replacement device after bone screws have been applied and after the insertion plate has been removed.

[0042] FIGS. 10a-f show top (FIG. 10a), lateral (FIG. 10b), posterior (FIG. 10c), anterior (FIG. 10d), postero-lateral (FIG. 10e), and antero-lateral (FIG. 10f) views of a retaining clip of the present invention.

[0043] FIGS. 11a-c show top (FIG. 11a), lateral (FIG. 11b), and anterior (FIG. 11c) views of a clip applicator of the insertion instrumentation of the present invention. FIG. 11d shows a postero-lateral perspective view of the clip applicator holding two retaining clips. FIG. 11e shows an antero-lateral perspective view of FIG. 11d.

[0044] FIG. 12a shows the clip applicator applying the retaining clips to the cervical disc replacement device. FIGS. 12b-h show anterior (FIG. 12b), posterior (FIG. 12c), top (FIG. 12d), bottom (FIG. 12e), lateral (FIG. 12f), antero-lateral perspective (FIG. 12g), and postero-lateral perspective (FIG. 12h) views of the cervical disc replacement device after the retaining clips have been applied.

[0045] FIGS. 13a-b show a prior art one level cervical fusion plate in anterior (FIG. 13a) and lateral (FIG. 13b) views. FIGS. 13c-d show a prior art two level cervical fusion plate in anterior (FIG. 13c) and lateral (FIG. 13d) views.

[0046] FIGS. 14a-e show an alternate, dual cervical disc replacement device configuration and alternate insertion plates for use therewith, in exploded perspective (FIG. 14a), anterior (FIG. 14b), posterior (FIG. 14c), lateral (FIG. 14d), and collapsed perspective (FIG. 14e) views.

[0047] FIGS. 15a-c show an alternate upper element of the configuration of FIGS. 14a-e, in posterior (FIG. 15a), anterior (FIG. 15b), and antero-lateral (FIG. 15c) views.

[0048] FIGS. 16a-c show an alternate lower element of the configuration of FIGS. 14a-e, in posterior (FIG. 16a), anterior (FIG. 16b), and antero-lateral (FIG. 16c) views.

[0049] FIGS. 17a-c show an alternate, upper, insertion plate of the configuration of FIGS. 14a-e in anterior (FIG. 17a), posterior (FIG. 17b), and antero-lateral (FIG. 17c) views.

[0050] FIGS. 18a-c show an alternate, lower, insertion plate of the configuration of FIGS. 14a-e in anterior (FIG. 18a), posterior (FIG. 18b), and antero-lateral (FIG. 18c) views.

DETAILED DESCRIPTION OF THE PREFERRED EMBODIMENTS

[0051] While the invention will be described more fully hereinafter with reference to the accompanying drawings, it is to be understood at the outset that persons skilled in the art may modify the invention herein described while achieving the functions and results of the invention. Accordingly, the descriptions that follow are to be understood as illustrative and exemplary of specific structures, aspects and features within the broad scope of the invention and not as limiting of such broad scope. Like numbers refer to similar features of like elements throughout.

[0052] A preferred embodiment of a cervical disc replacement device of the present invention, for use with the instrumentation of the present invention, will now be described.

[0053] Referring now to FIGS. 1a-3f, a top element 500 of the cervical disc replacement device 400 is shown in anterior (FIG. 1a), lateral (FIG. 1b), and bottom (FIG. 1c) views; a bottom element 600 of the cervical disc replacement device

400 is shown in anterior (FIG. 2a), lateral (FIG. 2b), and top (FIG. 2c) views; and an assembly 400 of the top and bottom elements 500,600 is shown in top (FIG. 3a), lateral (FIG. 3b), anterior (FIG. 3c), posterior (FIG. 3d), antero-lateral perspective (FIG. 3e), and postero-lateral perspective (FIG. 3f) views.

[0054] The cervical disc replacement device 400 is an alternate embodiment of the cervical disc replacement device of the '702 application. The illustrated alternate embodiment of the cervical disc replacement device is identical in structure to the cervical disc replacement device 100 in the '702 application (and thus like components are like numbered, but in the 400s rather than the 100s, in the 500s rather than the 200s, and in the 600s rather than the 300s), with the exception that the vertebral bone attachment flanges are configured differently, such that they are suitable for engagement by the instrumentation described herein. (It should be noted that, while the '702 application illustrated and described the cervical disc replacement device 100 as having an upper element flange 506 with two bone screw holes 508a,508b, and a lower element flange 606 with one bone screw hole 608, the '702 application explained that the number of holes and the configuration of the flanges could be modified without departing from the scope of the invention as described in the '702 application.)

[0055] More particularly, in this alternate embodiment, the upper element 500 of the cervical disc replacement device 400 has a vertebral body attachment structure (e.g., a flange) 506 that preferably extends upwardly from the anterior edge of the upper element 500, and preferably has a lateral curvature that approximates the curvature of the anterior periphery of the upper vertebral body against which it is to be secured. The attachment flange 506 is preferably provided with a flat recess 507, centered on the midline, that accommodates a clip 1150a (described below) of the present invention. The attachment flange 506 is further provided with at least one (e.g., two) bone screw holes 508a,508b, preferably symmetrically disposed on either side of the midline. Preferably, the holes 508a,508b have longitudinal axes directed along preferred bone screw driving lines. For example, in this alternate embodiment, the preferred bone screw driving lines are angled upwardly at 5 degrees and inwardly (toward one another) at 7 degrees (a total of 14 degrees of convergence), to facilitate a toenailing of the bone screws (described below and shown in FIGS. 12a-h). Centrally between the bone screw holes 508a,508b, at least one mounting feature (e.g., a mounting screw hole) 509 is provided for attaching the upper element 500 to an insertion plate 700 (described below) for implantation.

[0056] Similarly, in this alternate embodiment, the lower element 600 of the cervical disc replacement device 400 also has a vertebral body attachment structure (e.g., an oppositely directed and similarly configured vertebral body attachment flange) 606 that preferably extends downwardly from the anterior edge of the lower element 600, and preferably has a lateral curvature that approximates the curvature of the anterior periphery of the lower vertebral body against which it is to be secured. The attachment flange 606 is preferably provided with a flat recess 607, centered on the midline, that accommodates a clip 1150b (described below) of the present invention. The attachment flange 606 is further provided with at least one (e.g., two) bone screw holes 608a,608b, preferably symmetrically disposed on either side of the midline. Preferably, the holes 608a,608b have longitudinal

axes directed along preferred bone screw driving lines. For example, in this alternate embodiment, the preferred bone screw driving lines are angled downwardly at 5 degrees and inwardly (toward one another) at 7 degrees (a total of 14 degrees of convergence), to facilitate a toenailing of the bone screws (described below and shown in FIGS. 12a-h). Centrally between the bone screw holes 608a, 608b, at least one mounting feature (e.g., a mounting screw hole) 609 is provided for attaching the lower element 600 to the insertion plate 700 (described below) for implantation.

[0057] Prior to implantation of the cervical disc replacement device, the surgeon will prepare the intervertebral space. Typically, this will involve establishing access to the treatment site, removing the damaged natural intervertebral disc, preparing the surfaces of the endplates of the vertebral bones adjacent the intervertebral space, and distracting the intervertebral space. (It should be noted that the cervical disc replacement device of the present invention, and the instrumentation and implantation methods described herein, require minimal if any endplate preparation.) More particularly, after establishing access to the treatment site, the surgeon will remove the natural disc material, preferably leaving as much as possible of the annulus intact. Then, the surgeon will remove the anterior osteophyte that overhangs the mouth of the cervical intervertebral space, and any lateral osteophytes that may interfere with the placement of the cervical disc replacement device or the movement of the joint. Using a burr tool, the surgeon will then ensure that the natural lateral curvature of the anterior faces of the vertebral bodies is uniform, by removing any surface anomalies that deviate from the curvature. Also using the burr tool, the surgeon will ensure that the natural curvature of the endplate surface of the upper vertebral body, and the natural flatness of the endplate surface of the lower vertebral body, are uniform, by removing any surface anomalies that deviate from the curvature or the flatness. Thereafter, the surgeon will distract the intervertebral space to the appropriate height for receiving the cervical disc replacement device. Any distraction tool or method known in the art, e.g., a Caspar Distractor, can be used to effect the distraction and/or hold open the intervertebral space. Additionally or alternatively, the cervical disc replacement trials of the present invention can be used to distract the intervertebral space (as described below).

[0058] Referring now to FIGS. 4a-f, a cervical disc replacement trial 1200 of the present invention is shown in top (FIG. 4a), lateral (FIG. 4b), lateral (head only) (FIG. 4c), posterior (FIG. 4d), anterior (FIG. 4e), antero-lateral perspective (head only) (FIG. 4f), and postero-lateral perspective (head only) (FIG. 4g) views.

[0059] Preferably, a plurality of cervical disc replacement trials are provided primarily for use in determining the appropriate size of a cervical disc replacement device to be implanted (or whether a particular size of the cervical disc replacement device can be implanted) into the distracted cervical intervertebral space (e.g., the cervical disc replacement device 400 of FIGS. 1a-3f). Preferably, for each cervical disc replacement device to be implanted, a plurality of sizes of the cervical disc replacement device would be available. That is, preferably, a plurality of the same type of cervical disc replacement device would be available, each of the plurality having a respective footprint and depth dimension combination that allows it to fit within a correspondingly dimensioned intervertebral space. For example, the

plurality of cervical disc replacement devices could include cervical disc replacement devices having oval footprints being 12 mm by 14 mm, 14 mm by 16 mm, or 16 mm by 18 mm, and depths ranging from 6 mm to 14 mm in 1 mm increments, for a total of 27 devices. Accordingly, preferably, each of the plurality of trials for use with a particular plurality of differently sized cervical disc replacement devices would have a respective oval footprint and depth dimension set corresponding to the footprint and depth dimension set of a respective one of the plurality of differently sized cervical disc replacement devices. For example, the plurality of trials for use with the set of cervical disc replacement devices described, for example, could include trials having oval footprints being 12 mm by 14 mm, 14 mm by 16 mm, or 16 mm by 18 mm, and depths ranging from 6 mm to 14 mm in 1 mm increments, for a total of 27 static trials. It should be understood that the cervical disc replacement devices and/or the trials can be offered in a variety of dimensions without departing from the scope of the invention, and that the dimensions specifically identified and quantified herein are merely exemplary. Moreover, it should be understood that the set of trials need not include the same number of trials for each cervical disc replacement device in the set of cervical disc replacement devices, but rather, none, one, or more than one trial can be included in the trial set for any particular cervical disc replacement device in the set.

[0060] Each of the cervical disc replacement trials (the cervical disc replacement trial 1200 shown in FIGS. 4a-g is exemplary for all of the trials in the plurality of trials; preferably the trials in the plurality of trials differ from one another only with regard to certain dimensions as described above) includes a shaft 1202 having a configured distal end 1204 and a proximal end having a handle 1206. Preferably, the proximal end is provided with a manipulation features (e.g., a hole 1216) to, e.g., decrease the weight of the trial 1200, facilitate manipulation of the trial 1200, and provide a feature for engagement by an instrument tray protrusion. The distal end is configured to approximate relevant dimensions of the cervical disc replacement device. More particularly in the illustrated embodiment (for example), the distal end 1204 has a trial configuration (e.g., a head 1208 having an oval footprint dimensioned at 12 mm by 14 mm, and a thickness of 6 mm). The upper surface 1210 of the head 1208 is convex, similar to the configuration of the vertebral body contact surface of the upper element 500 of the cervical disc replacement device 400 (but without the teeth). The lower surface 1212 of the head 1208 is flat, similar to the configuration of the vertebral body contact surface of the lower element 600 of the cervical disc replacement device 400 (but without the teeth). The illustrated embodiment, therefore, with these dimensions, approximates the size of a cervical disc replacement device having the same height and footprint dimensions. The cervical disc replacement trial, not having the teeth, can be inserted and removed from the intervertebral space without compromising the endplate surfaces. The cervical disc replacement trial 1200 further has an over-insertion prevention features (e.g., a vertebral body stop 1214) preferably disposed at the anterior edge of the head 1208, to engage the anterior surface of the upper vertebral body before the trial 1200 is inserted too far into the intervertebral space. The body of the trial 1200 preferably has one or more structural support features (e.g., a rib 1216 extending anteriorly from the head 1208 below the shaft 1202) that provides stability, e.g., to the shaft 1202 for

upward and downward movement, e.g., if the head **1208** must be urged into the intervertebral space by moving the shaft **1202** in this manner. Further, preferably as shown, the head **1208** is provided with an insertion facilitation features (e.g., a taper, decreasing posteriorly) to facilitate insertion of the head **1208** into the intervertebral space by, e.g., acting as a wedge to urge the vertebral endplates apart. Preferably, as shown, the upper surface **1210** is fully tapered at approximately 5 degrees, and the distal half of the lower surface **1212** is tapered at approximately 4 degrees.

[0061] Accordingly, the surgeon can insert and remove at least one of the trials (or more, as necessary) from the prepared intervertebral space. As noted above, the trials are useful for distracting the prepared intervertebral space. For example, starting with the largest distractor that can be wedged in between the vertebral bones, the surgeon will insert the trial head **1208** (the tapering of the trial head **1208** facilitates this insertion by acting as a wedge to urge the vertebral endplates apart), and then lever the trial handle **1206** up and down to loosen the annulus and surrounding ligaments to urge the bone farther apart. Once the annulus and ligaments have been loosened, the surgeon removes the trial head **1208** from the intervertebral space, and replaces it with the next largest (in terms of height) trial head **1208**. The surgeon then levers the trial handle **1206** up and down to further loosen the annulus and ligaments. The surgeon then proceeds to remove and replace the trial head **1208** with the next largest (in terms of height) trial head **1208**, and continues in this manner with larger and larger trials until the intervertebral space is distracted to the appropriate height. This gradual distraction method causes the distracted intervertebral space to remain at the distracted height with minimal subsidence before the cervical disc replacement device is implanted. The appropriate height is one that maximizes the height of the intervertebral space while preserving the annulus and ligaments.

[0062] Regardless of the distraction method used, the cervical disc replacement trials are useful for finding the cervical disc replacement device size that is most appropriate for the prepared intervertebral space, because each of the trial heads approximates the relevant dimensions of an available cervical disc replacement device. Once the intervertebral space is distracted, the surgeon can insert and remove one or more of the trial heads to determine the appropriate size of cervical disc replacement device to use. Once the appropriate size is determined, the surgeon proceeds to implant the selected cervical disc replacement device.

[0063] A preferred method of, and instruments for use in, implanting the cervical disc replacement device will now be described.

[0064] Referring now to FIGS. **5a-f**, an insertion plate **700** of the insertion instrumentation of the present invention is shown in top (FIG. **5a**), lateral (FIG. **5b**), anterior (FIG. **5c**), and posterior (FIG. **5d**) views. FIGS. **5e** and **5f** show anterior (FIG. **5e**) and antero-lateral perspective (FIG. **5f**) views of the insertion plate **700** mounted to the cervical disc replacement device **400**.

[0065] The insertion plate **700** has a base **702** with a first mounting area **704a** (preferably an upwardly extending flange) and a second mounting area **704b** (preferably a downwardly extending flange), and a primary attachment feature (e.g., an anteriorly extending central stem) **706**. The connection of the stem **706** to the base **702** preferably

includes an axial rotation prevention feature, e.g., two oppositely and laterally extending key flanges **708a,708b**. The stem **706** preferably has a proximal portion **710** that is tapered to have a decreasing diameter away from the base **702**. That is, the tapered proximal portion **710** has an initial smaller diameter that increases toward the base **702** gradually to a final larger diameter. The base **702** preferably has a posteriorly extending ledge **716** that has a flat upper surface and a curved lower surface.

[0066] The insertion plate **700** is mounted to the cervical disc replacement device **400** to facilitate the preferred simultaneous implantation of the upper and lower elements **500, 600**. The upper and lower elements **500,600** are held by the insertion plate **700** in a preferred relationship to one another that is suitable for implantation. More particularly, as shown in FIGS. **3a-f, 5e, and 5f**, the elements **500,600** are preferably axially rotationally aligned with one another, with the element perimeters and flanges **506,606** axially aligned with one another, and held with the bearing surfaces **512,612** in contact. The ledge **716** maintains a separation between the anterior portions of the inwardly facing surfaces of the elements **500,600** to help establish and maintain this preferred relationship, with the flat upper surface of the ledge **716** in contact with the flat anterior portion of the inwardly facing surface of the upper element **500**, and the curved lower surface of the ledge **716** in contact with the curved anterior portion of the inwardly facing surface of the lower element **600**.

[0067] While any suitable method or mechanism can be used to mount the elements **500,600** to the insertion plate **700**, a preferred arrangement is described. That is, it is preferred, as shown and as noted above, that the flanges **506,606** of the elements **500,600** (in addition to having the bone screw holes **508a,508b,608a,608b** described above) each have at least one mounting feature (e.g., mounting screw hole **509,609**), and the insertion plate **700** has two (at least two, each one alignable with a respective mounting screw hole **509,609**) corresponding mounting features (e.g., mounting screw holes **712a,712b**), spaced to match the spacing of (and each be colinear with a respective one of) the mounting screw holes **509,609** on the flanges **506,606** of the elements **500,600** of the cervical disc replacement device **400** when those elements **500,600** are disposed in the preferred relationship for implantation. Accordingly, mounting screws **714a,714b** or other suitable fixation devices are secured through the colinear mounting screw hole pairs **509,712a** and **609,712b** (one screw through each pair), such that the elements **500,600** are immovable with respect to the insertion plate **700** and with respect to one another. Thus, in this configuration, the upper element **500**, lower element **600**, and insertion plate **700** construct is manipulatable as a single unit.

[0068] Preferably, for each size of cervical disc replacement device, the described configuration is established (and rendered sterile in a blister pack through methods known in the art) prior to delivery to the surgeon. That is, as described below, the surgeon will simply need to open the blister pack and apply the additional implantation tools to the construct in order to implant the cervical disc replacement device. Preferably, the configuration or dimensions of the insertion plate can be modified (either by providing multiple different insertion plates, or providing a single dynamically modifiable insertion plate) to accommodate cervical disc replacement devices of varying heights. For example, the positions

of the mounting screw holes **712a,712b** on the flanges **704a,704b** can be adjusted (e.g., farther apart for replacement devices of greater height, and close together for replacement devices of lesser height), and the size of the flanges **704a,704b** can be adjusted to provide structural stability for the new hole positions. Preferably, in other respects, the insertion plate configuration and dimensions need not be modified, to facilitate ease of manufacturing and lower manufacturing costs.

[0069] It should be noted that the described configuration of the construct presents the cervical disc replacement device to the surgeon in a familiar manner. That is, by way of explanation, current cervical fusion surgery involves placing a fusion device (e.g., bone or a porous cage) in between the cervical intervertebral bones, and attaching a cervical fusion plate to the anterior aspects of the bones. Widely used cervical fusion devices (an example single level fusion plate **1300** is shown in anterior view in FIG. **13a** and in lateral view in FIG. **13b**) are configured with a pair of laterally spaced bone screw holes **1302a,1302b** on an upper end **1304** of the plate **1300**, and a pair of laterally spaced bone screw holes **1306a,1306b** on a lower end **1308** of the plate **1300**. To attach the plate **1300** to the bones, two bone screws are disposed through the upper end's bone screw holes **1302a,1302b** and into the upper bone, and two bone screws are disposed through the lower end's bone screw holes **1306a,1306b** and into the lower bone. This prevents the bones from moving relative to one another, and allows the bones to fuse to one another with the aid of the fusion device.

[0070] Accordingly, as can be seen in FIG. **5e**, when the upper and lower elements **500,600** of the cervical disc replacement device **400** are held in the preferred spatial relationship, the flanges **506,606** of the elements **500,600**, and their bone screw holes **508a,508b**, present to the surgeon a cervical hardware and bone screw hole configuration similar to a familiar cervical fusion plate configuration. The mounting of the elements **500,600** to the insertion plate **700** allows the elements **500,600** to be manipulated as a single unit for implantation (by manipulating the insertion plate **700**), similar to the way a cervical fusion plate is manipulatable as a single unit for attachment to the bones. This aspect of the present invention simplifies and streamlines the cervical disc replacement device implantation procedure.

[0071] As noted above, the cervical disc replacement device **400** and insertion plate **700** construct is preferably provided sterile (e.g., in a blister pack) to the surgeon in an implant tray (the tray preferably being filled with constructs for each size of cervical disc replacement device). The construct is preferably situated in the implant tray with the stem **706** of the insertion plate **700** facing upwards for ready acceptance of the insertion handle **800** (described below).

[0072] Referring now to FIGS. **6a-e**, an insertion handle **800** of the insertion instrumentation of the present invention is shown in top (FIG. **6a**), lateral (FIG. **6b**), anterior (FIG. **6c**), and postero-lateral (distal end only) (FIG. **6d**) views. FIG. **6e** shows an antero-lateral perspective view of the insertion handle **800** attached to the stem **706** of the insertion plate **700**. FIG. **6f** shows a magnified view of the distal end of FIG. **6e**.

[0073] The insertion handle **800** is provided primarily for engaging the stem **706** of the insertion plate **700** so that the cervical disc replacement device **400** and insertion plate **700** construct can be manipulated into and within the treatment

site. The insertion handle **800** has a shaft **802** with an attachment feature (e.g., a longitudinal bore) **804** at a distal end **806** and a manipulation feature (e.g., a flange) **810** at a proximal end **808**. Preferably, the longitudinal bore **804** has an inner taper at the distal end **806** such that the inner diameter of the distal end **806** decreases toward the distal end **806**, from an initial larger inner diameter at a proximal portion of the distal end **806** to a final smaller inner diameter at the distal edge of the distal end **806**. The distal end **806** also preferably has an axial rotation prevention feature, e.g., two (at least one) key slots **814a,814b** extending proximally from the distal end **806**. Each slot **814a,814b** is shaped to accommodate the key flanges **708a,708b** at the connection of the base **702** to the stem **706** when the distal end **806** is engaged with the stem **706**. The material from which the insertion handle **800** is formed (preferably, e.g., Ultem™), and also the presence of the key slots **814a,814b**, permits the diameter of the hollow distal end **806** to expand as needed to engage the tapered stem **706** of the insertion plate **700**. More particularly, the resting diameter (prior to any expansion) of the hollow distal end **806** of the insertion handle **800** is incrementally larger than the initial diameter of the tapered proximal portion **710** of the stem **706** of the insertion plate **700**, and incrementally smaller than the final diameter of the tapered proximal portion **710** of the stem **706** of the insertion plate **700**. Accordingly, longitudinally aligning the insertion handle shaft **802** with the stem **706**, and thereafter pushing the hollow distal end **806** of the insertion handle shaft **802** toward the insertion plate base **702**, causes the hollow distal end **806** to initially readily encompass the tapered proximal portion **710** of the stem **706** (because the initial diameter of the tapered proximal portion **710** is smaller than the resting diameter of the hollow tapered distal end **806**). With continued movement of the insertion handle shaft **802** toward the insertion plate base **702**, the hollow distal end **806** is confronted by the increasing diameter of the tapered proximal portion **710**. Accordingly, the diameter of the hollow distal end **806** expands (by permission of the shaft **802** body material and the key slots **814a,814b** as the slots narrow) under the confrontation to accept the increasing diameter. Eventually, with continued movement under force, the inner surface of the hollow distal end **806** is friction-locked to the outer surface of the tapered proximal portion **710**. Each of the key slots **814a,814b** straddles a respective one of the key flanges **708a,708b** at the connection of the base **702** to the stem **706**. This enhances the ability of the insertion handle **800** to prevent rotation of the insertion handle shaft **802** relative to the insertion plate **700** (about the longitudinal axis of the insertion handle shaft **802**). It should be understood that other methods or mechanisms of establishing engagement of the stem **706** by the insertion handle **800** can be used without departing from the scope of the invention.

[0074] Once the insertion handle **800** is engaged with the insertion plate **700**, manipulation of the insertion handle shaft **802** effects manipulation of the cervical disc replacement device **400** and insertion plate **700** construct. The surgeon can therefore remove the construct from the implant tray, and insert the construct into the treatment area. More particularly, according to the implantation procedure of the invention, after the surgeon properly prepares the intervertebral space (removes the damaged natural disc, modifies the bone surfaces that define the intervertebral space, and distracts the intervertebral space to the appropriate height), the

surgeon inserts the cervical disc replacement device **400** into the intervertebral space from an anterior approach, such that the upper and lower elements **500,600** are inserted between the adjacent vertebral bones with the element footprints fitting within the perimeter of the intervertebral space and with the teeth of the elements' vertebral body contact surfaces **502,602** engaging the vertebral endplates, and with the flanges **506,606** of the upper and lower elements **500,600** flush against the anterior faces of the upper and lower vertebral bones, respectively. (As discussed above, the flanges **506,606** preferably have a lateral curvature that approximates the lateral curvature of the anterior faces of the vertebral bones.)

[**0075**] Referring now to FIGS. **7a-e**, an insertion pusher **900** of the insertion instrumentation of the present invention is shown in top (FIG. **7a**), lateral (FIG. **7b**), and anterior (FIG. **7c**) views. FIG. **7d** shows an antero-lateral perspective view of the insertion pusher **900** inserted into the insertion handle **800**. FIG. **7e** shows a magnified view of the proximal end of FIG. **7d**.

[**0076**] Once the construct is properly positioned in the treatment area, the surgeon uses the insertion pusher **900** to disengage the insertion handle shaft **802** from the stem **706** of the insertion plate **700**. More particularly, the insertion pusher **900** has a longitudinal shaft **902** having a preferably blunt distal end **904** and a proximal end **906** preferably having a flange **908**. The shaft **902** of the insertion pusher **900** has a diameter smaller than the inner diameter of the insertion handle shaft **802**, such that the shaft **902** of the insertion pusher **900** can be inserted into and translated within the longitudinal bore **804** of the insertion handle shaft **802**. (The longitudinal bore **804** preferably, for the purpose of accommodating the insertion pusher **900** and other purposes, extends the length of the insertion handle shaft **802**.) The shaft **902** of the insertion pusher **900** is preferably as long as (or, e.g., at least as long as) the longitudinal bore **804**. Accordingly, to remove the insertion handle shaft **802** from the insertion plate **700**, the shaft **902** of the insertion pusher **900** is inserted into the longitudinal bore **804** of the insertion handle shaft **802** and translated therein until the blunt distal end **904** of the pusher shaft **802** is against the proximal end of the tapered stem **706** of the insertion plate **700**. Because the shaft **902** of the insertion pusher **900** is as long as the longitudinal bore **804** of the insertion handle shaft **802**, the flange **810** of the insertion handle **800** and the flange **908** of the insertion pusher **900** are separated by a distance (see FIGS. **7d** and **7e**) that is equivalent to the length of that portion of the stem **706** that is locked in the distal end **806** of the insertion handle shaft **802**. Accordingly, a bringing together of the flanges **810,908** (e.g., by the surgeon squeezing the flanges **810,908** toward one another) will overcome the friction lock between the distal end **806** of the insertion handle shaft **802** and the stem **706** of the insertion plate **700**, disengaging the insertion handle shaft **802** from the insertion plate **700** without disturbing the disposition of the cervical disc replacement device **400** and insertion plate **700** construct in the treatment area.

[**0077**] Referring now to FIGS. **8a-e**, a drill guide **1000** of the insertion instrumentation of the present invention is shown in top (FIG. **8a**), lateral (FIG. **8b**), and anterior (FIG. **8c**) views. FIG. **8d** shows an antero-lateral perspective view of the drill guide **1000** inserted onto the stem **706** of the insertion plate **700**. FIG. **8e** shows a magnified view of the distal end of FIG. **8d**.

[**0078**] Once the insertion handle **800** has been removed, the surgeon uses the drill guide **1000** to guide the surgeon's drilling of the bone screws (described below) through the bone screw holes **508a,508b** and **608a,608b** of the upper **500** and lower **600** elements' flanges **506,606** and into the vertebral bones. More particularly, the drill guide **1000** has a longitudinal shaft **1002** having a configured distal end **1004** and a proximal end **1006** with a manipulation feature (e.g., lateral extensions **1008a,1008b**). The lateral extensions **1008a,1008b** are useful for manipulating the shaft **1002**. The distal end **1004** is configured to have a shaft guiding feature (e.g., a central bore **1010**) suitable for guiding the shaft **1002** in relation to the stem **706** of the insertion plate **700** therethrough. For example, the central bore **1010** accommodates the stem **706** so that the drill guide **1000** can be placed on and aligned with the stem **706**. The longitudinal axis of the bore **1010** is preferably offset from the longitudinal axis of the drill guide shaft **1002**. The distal end **1004** is further configured to have two guide bores **1012a,1012b** that have respective longitudinal axes at preferred bone screw drilling paths relative to one another. More particularly, the central bore **1010**, drill guide shaft **1002**, and guide bores **1012a,1012b**, are configured on the distal end **1004** of the drill guide **1000** such that when the central bore **1010** is disposed on the stem **706** of the insertion plate **700** (see FIGS. **8d** and **8e**), the drill guide shaft **1002** can be rotated on the stem **706** into either of two preferred positions in which the guide bores **1012a,1012b** are aligned with the bone screw holes **508a,508b** or **608a,608b** on either of the flanges **506** or **606**. Stated alternatively, in a first preferred position (see FIGS. **8d** and **8e**), the drill guide **1000** can be used to guide bone screws through the bone screw holes **508a,508b** in the flange **506** of the upper element **500**, and in a second preferred position (in which the drill guide is rotated 180 degrees, about the longitudinal axis of the stem **706**, from the first preferred position), the same drill guide **1000** can be used to guide bone screws through the bone screw holes **608a,608b** in the flange **606** of the lower element **600**. When the drill guide **1000** is disposed in either of the preferred positions, the longitudinal axes of the guide bores **1012a,1012b** are aligned with the bone screw holes **508a,508b** or **608a,608b** on the flanges **506** or **606**, and are directed along preferred bone screw drilling paths through the bone screw holes.

[**0079**] Accordingly, to secure the upper element flange **506** to the upper vertebral body, the surgeon places the drill guide shaft **1002** onto the stem **706** of the insertion plate **700**, and rotates the drill guide **1000** into the first preferred position. Preferably, the surgeon then applies an upward pressure to the drill guide **1000**, urging the upper element **500** tightly against the endplate of the upper vertebral body. Using a suitable bone drill and cooperating drill bit, the surgeon drills upper tap holes for the upper bone screws. Once the upper tap holes are drilled, the surgeon rotates the drill guide shaft **1002** on the stem **706** of the insertion plate **700** until the guide bores **1012a,1012b** no longer cover the upper bone screw holes **508a,508b**. The surgeon can then screw the upper bone screws into the upper tap holes using a suitable surgical bone screw driver.

[**0080**] Additionally, to secure the lower element flange **606** to the lower vertebral body, the surgeon further rotates the drill guide shaft **1002** on the stem **706** of the insertion plate **700** until the drill guide **1000** is in the second preferred position. Preferably, the surgeon then applies a downward

pressure to the drill guide **1000**, urging the lower element **600** tightly against the endplate of the lower vertebral body. Using the suitable bone drill and cooperating drill bit, the surgeon drills lower tap holes for the lower bone screws. Once the lower tap holes are drilled, the surgeon rotates the drill guide shaft **1002** on the stem **706** of the insertion plate **700** until the guide bores **1012a,1012b** no longer cover the lower bone screw holes **608a,608b**. The surgeon can then screw the lower bone screws into the lower tap holes using the suitable surgical bone screw driver.

[0081] It should be noted that the bone screws (or other elements of the invention) may include features or mechanisms that assist in prevent screw backup. Such features may include, but not be limited to, one or more of the following: titanium plasma spray coating, bead blasted coating, hydroxylapatite coating, and grooves on the threads.

[0082] Once the elements **500,600** are secured to the adjacent vertebral bones, the surgeon removes the drill guide **1000** from the stem **706** of the insertion plate **700** and from the treatment area (see FIG. **9a**). Using a suitable surgical screw driver, the surgeon then removes the mounting screws **714a,714b** that hold the insertion plate **700** against the elements' flanges **506,606**, and removes the insertion plate **700** and the mounting screws **714a,714b** from the treatment area (see FIG. **9b**).

[0083] Referring now to FIGS. **10a-f**, a retaining clip **1150a** of the present invention is shown in top (FIG. **10a**), lateral (FIG. **10b**), posterior (FIG. **10c**), anterior (FIG. **10d**), postero-lateral perspective (FIG. **10e**), and antero-lateral perspective (FIG. **10f**) views. (The features of retaining clip **1150a** are exemplary of the features of the like-numbered features of retaining clip **1150b**, which are referenced by b's rather than a's.) Referring now to FIGS. **11a-e**, a clip applicator **1100** of the insertion instrumentation of the present invention is shown in top (FIG. **11a**), lateral (FIG. **11b**), and anterior (FIG. **11c**) views. FIG. **11d** shows a postero-lateral perspective view of the clip applicator **1100** holding two retaining clips **1150a,1150b** of the present invention. FIG. **11e** shows an antero-lateral perspective view of FIG. **11d**. Referring now to FIGS. **12a-h**, the clip applicator **1100** is shown applying the retaining clips **1150a,1150b** to the cervical disc replacement device **400**. FIGS. **12b-h** show anterior (FIG. **12b**), posterior (FIG. **12c**), top (FIG. **12d**), bottom (FIG. **12e**), lateral (FIG. **12f**), antero-lateral perspective (FIG. **12g**), and postero-lateral perspective (FIG. **12h**) views of the cervical disc replacement device **400** after the retaining clips **1150a,1150b** have been applied.

[0084] Once the mounting screws **714a,714b** and the insertion plate **700** are removed, the surgeon uses the clip applicator **1100** to mount the retaining clips **1150a,1150b** on the flanges **506,606** to assist in retaining the bone screws. As shown in FIGS. **10a-f**, each of the clips **1150a,1150b** preferably has an applicator attachment feature (e.g., a central attachment bore **1152a,1152b**) and, extending therefrom, a pair of bone screw retaining features (e.g., oppositely directed laterally extending flanges **1156a,1156b** and **1158a,1158b**) and a flange attachment feature (e.g., an upwardly (or downwardly) extending hooked flange **1160a,1160b**). The extent of the hook flange **1160a,1160b** is preferably formed to bend in toward the base of the formation is wider than the mouth width of the formation, and such that the extent is spring biased by its material composition toward the base. The enclosure width of the formation accommodates the

width of the body of a flange **506,606** of the cervical disc replacement device **400**, but the mouth width of the formation is smaller than the width of the flange **506,606**. Accordingly, and referring now to FIGS. **12b-h**, each clip **1150a,1150b** can be applied to an element flange **506,606** such that the hook flange **1160a,1160b** grips the element flange **506,606**, by pressing the hook's mouth against the edge of the element flange **506,606** with enough force to overcome the bias of the hook flange's extent toward the base, until the flange **506,606** is seated in the hook's enclosure. The attachment bore **1152a,1152b** of the clip **1150a,1150b** is positioned on the clip **1150a,1150b** such that when the clip **1150a,1150b** is properly applied to the flange **506,606**, the attachment bore **1152a,1152b** is aligned with the mounting screw hole **509,609** on the flange **506,606** (see FIGS. **12b-h**). Further, the posterior opening of the attachment bore **1152a,1152b** is preferably surrounded by a clip retaining features (e.g., a raised wall **1162a,1162b**), the outer diameter of which is dimensioned such that the raised wall **1162a,1162b** fits into the mounting screw hole **509,609** on the element flange **506,606**. Thus, when the clip **1150a,1150b** is so applied to the element flange **506,606**, the element flange **506,606** will be received into the hook's enclosure against the spring bias of the hook's extent, until the attachment bore **1152a,1152b** is aligned with the mounting screw hole **509,609**, at which time the raised wall **1162a,1162b** will snap into the mounting screw hole **509,609** under the force of the hook's extent's spring bias. This fitting prevents the clip **1150a,1150b** from slipping off the flange **506,606** under stresses in situ. Each of the laterally extending flanges **1156a,1156b** and **1158a,1158b** of the clip **1150a,1150b** is sized to cover at least a portion of a respective one of the bone screw heads when the clip **1150a,1150b** is attached in this manner to the flange **506,606** (see FIGS. **12b-h**), so that, e.g., the clips **1150a,1150b** help prevent the bone screws from backing out.

[0085] Referring again to FIGS. **11a-e**, the clip applicator **1100** has a pair of tongs **1102a,1102b** hinged at a proximal end **1104** of the clip applicator **1100**. Each tong **1102a,1102b** has an attachment feature (e.g., a nub **1108a,1108b**) at a distal end **1106a,1106b**. Each nub **1108a,1108b** is dimensioned such that it can be manually friction locked into either of the attachment bores **1152a,1152b** of the retaining clips **1150a,1150b**. Thus, both clips **1150a,1150b** can be attached to the clip applicator **1100**, one to each tong **1102a,1102b** (see FIGS. **11d** and **11e**). Preferably, as shown in FIGS. **11d** and **11e**, the clips **1150a,1150b** are attached so that their hook flanges **1154a,1154b** are directed toward one another, so that they are optimally situated for attachment to the element flanges **506,606** of the cervical disc replacement device **400** (see FIG. **12a**).

[0086] Preferably, the clips **1150a,1150b** are attached to the clip applicator **1100** as described above prior to delivery to the surgeon. The assembly is preferably provided sterile to the surgeon in a blister pack. Accordingly, when the surgeon is ready to mount the clips **1150a,1150b** to the element flanges **506,606** of the cervical disc replacement device **400**, the surgeon opens the blister pack and inserts the tongs **1102a,1102b** of the clip applicator **1100** (with the clips **1150a,1150b** attached) into the treatment area.

[0087] Accordingly, and referring again to FIGS. **12a-h**, the clips **1150a,1150b** can be simultaneously clipped to the upper **500** and lower **600** elements' flanges **506,606** (one to each flange **506,606**) using the clip applicator **1100**. More

particularly, the mouths of the clips **1150a,1150b** can be brought to bear each on a respective one of the flanges **506,606** by manually squeezing the tongs **1102a,1102b** (having the clips **1150a,1150b** attached each to a set of the distal ends of the tongs **1102a,1102b**) toward one another when the mouths of the clips **1150a,1150b** are suitably aligned with the flanges **506,606** (see FIG. **12a**). Once the clips **1150a,1150b** have been attached to the flanges **506,660** with the raised walls **1162a,1162b** fitting into the mounting screw holes **509,609** of the flanges **506,606**, the clip applicator **1100** can be removed from the clips **1150a,1150b** by manually pulling the nubs **1108a,1108b** out of the attachment bores **1152a,1152b**, and the clip applicator **1100** can be removed from the treatment area.

[**0088**] After implanting the cervical disc replacement device **400** as described, the surgeon follows accepted procedure for closing the treatment area.

[**0089**] Referring now to FIGS. **14a-e**, an alternate dual cervical disc replacement device configuration and alternate insertion plates for use therewith, suitable, for example, for implantation in two adjacent cervical intervertebral spaces, are illustrated in exploded perspective (FIG. **14a**), anterior (FIG. **14b**), posterior (FIG. **14c**), lateral (FIG. **14d**), and collapsed perspective (FIG. **14e**) views. Referring now also to FIGS. **15a-c**, an alternate upper element of the configuration is shown in posterior (FIG. **15a**), anterior (FIG. **15b**), and antero-lateral (FIG. **15c**) views. Referring now also to FIGS. **16a-c**, an alternate lower element of the configuration is shown in posterior (FIG. **16a**), anterior (FIG. **16b**), and antero-lateral (FIG. **16c**) views. Referring now also to FIGS. **17a-c**, an alternate, upper, insertion plate of the configuration is shown in anterior (FIG. **17a**), posterior (FIG. **17b**), and antero-lateral (FIG. **17c**) views. Referring now also to FIGS. **18a-c**, an alternate, lower, insertion plate of the configuration is shown in anterior (FIG. **18a**), posterior (FIG. **18b**), and antero-lateral (FIG. **18c**) views.

[**0090**] More particularly, the alternate dual cervical disc replacement device configuration **1350** is suitable, for example, for implantation into two adjacent cervical intervertebral spaces. The configuration preferably, as shown, includes an alternate, upper, cervical disc replacement device **1400** (including an upper element **1500** and an alternate, lower, element **1600**), for implantation into an upper cervical intervertebral space, and further includes an alternate, lower, cervical disc replacement device **2400** (including an alternate, upper, element **2500** and a lower element **2600**), for implantation into an adjacent, lower, cervical intervertebral space. The illustrated alternate, upper, embodiment of the cervical disc replacement device is identical in structure to the cervical disc replacement device **400** described above (and thus like components are like numbered, but in the 1400s rather than the 400s, in the 1500s rather than the 500s, and in the 1600s rather than the 600s), with the exception that the flange **1606** of the lower element **1600** is configured differently and without bone screw holes. The illustrated alternate, lower, embodiment of the cervical disc replacement device is identical in structure to the cervical disc replacement device **400** described above (and thus like components are like numbered, but in the 2400s rather than the 400s, in the 2500s rather than the 500s, and in the 2600s rather than the 600s), with the exception that the flange **2506** of the upper element **2500** is configured differently and without bone screw holes.

[**0091**] More particularly, in the alternate, upper, cervical disc replacement device **1400** of this alternate configuration, the flange **1606** of the lower element **1600** does not have bone screw holes, but has at least one mounting feature (e.g., a mounting screw hole) **1609** for attaching the lower element **1600** to the alternate, upper, insertion plate **1700** (described below). Similarly, and more particularly, in the alternate, lower, cervical disc replacement device **2400** of this alternate configuration, the flange **2506** of the upper element **2500** does not have bone screw holes, but has at least one mounting feature (e.g., a mounting screw hole) **2509** for attaching the upper element **2500** to the alternate, lower, insertion plate **2700** (described below). As can be seen particularly in FIGS. **14a-c**, **15b**, **16b**, **17a**, and **18a**, the extent of the flange **1606** is laterally offset to the right (in an anterior view) from the midline (and preferably limited to support only the mounting screw hole **1609**), and the extent of the flange **2506** is laterally offset to the left (in an anterior view) from the midline (and preferably limited to support only the mounting screw hole **2509**), so that the flanges **1606,2506** avoid one another when the alternate lower element **1600** of the alternate, upper, cervical disc replacement device **1400**, and the alternate upper element **2500** of the alternate, lower, cervical disc replacement device **2400**, are implanted in this alternate configuration (FIGS. **14a-e**).

[**0092**] It should be noted that the alternate, upper, cervical disc replacement device **1400** does not require both elements **1500,1600** to be secured to a vertebral body. Only one need be secured to a vertebral body, because due to natural compression in the spine pressing the elements' bearing surfaces together, and the curvatures of the saddle-shaped bearing surfaces preventing lateral, anterior, or posterior movement relative to one another when they are compressed against one another, if one element (e.g., the upper element **1500**) is secured to a vertebral body (e.g., to the upper vertebral body by bone screws through the bone screw holes **1508a,1508b** of the element flange **1506**), the other element (e.g., the alternate, lower, element **1600**) cannot slip out of the intervertebral space, even if that other element is not secured to a vertebral body (e.g., to the middle vertebral body). Similarly, the alternate, lower, cervical disc replacement device **2400** does not require both elements **2500,2600** to be secured to a vertebral body. Only one need be secured to a vertebral body, because due to natural compression in the spine pressing the elements' bearing surfaces together, and the curvatures of the saddle-shaped bearing surfaces preventing lateral, anterior, or posterior movement relative to one another when they are compressed against one another, if one element (e.g., the lower element **2600**) is secured to a vertebral body (e.g., to the lower vertebral body by bone screws through the bone screw holes **2608a,2608b** of the element flange **2606**), the other element (e.g., the alternate, upper, element **2500**) cannot slip out of the intervertebral space, even if that other element is not secured to a vertebral body (e.g., to the middle vertebral body).

[**0093**] Accordingly, the alternate, upper, insertion plate **1700** is provided to facilitate a preferred simultaneous implantation of the upper and lower elements **1500,1600** of the alternate, upper, cervical disc replacement device **1400** into the upper intervertebral space. Similarly, the alternate, lower, insertion plate **2700** is provided to facilitate a preferred simultaneous implantation of the upper and lower elements **2500,2600** of the alternate, lower, cervical disc replacement device **2400** into the lower intervertebral space.

The upper and lower elements **1500,1600** are held by the insertion plate **1700** (preferably using mounting screws **1714a,1714b**) in a preferred relationship to one another that is suitable for implantation, identical to the preferred relationship in which the upper and lower elements **500,600** are held by the insertion plate **700** as described above. Similarly, the upper and lower elements **2500,2600** are held by the insertion plate **2700** (preferably using mounting screws **2714a,2714b**) in a preferred relationship to one another that is suitable for implantation, identical to the preferred relationship in which the upper and lower elements **500,600** are held by the insertion plate **700** as described above.

[0094] The illustrated alternate, upper, insertion plate **1700** is identical in structure to the insertion plate **700** described above (and thus like components are like numbered, but in the 1700s rather than the 700s), with the exception that the lower flange **1704b** is offset from the midline (to the right in an anterior view) to align its mounting screw hole **1712b** with the offset mounting screw hole **1609** of the alternate lower element **1600** of the alternate, upper, cervical disc replacement device **1400**. Similarly, the illustrated alternate, lower, insertion plate **2700** is identical in structure to the insertion plate **700** described above (and thus like components are like numbered, but in the 2700s rather than the 700s), with the exception that the upper flange **2704a** is offset from the midline (to the left in an anterior view) to align its mounting screw hole **2712a** with the offset mounting screw hole **2509** of the alternate upper element **2500** of the alternate, lower, cervical disc replacement device **2400**.

[0095] Accordingly, the upper and lower elements **1500,1600**, being held by the insertion plate **1700**, as well as the upper and lower elements **2500,2600**, being held by the insertion plate **2700**, can be implanted using the insertion handle **800**, insertion pusher **900**, drill guide **1000**, clips **1150a,1150b** (one on the upper element flange **1506**, and one on the lower element flange **2606**, because only the upper element **1500** and the lower element **2600** are secured by bone screws), and clip applicator **1100**, in the manner described above with respect to the implantation of the cervical disc replacement device **400**.

[0096] It should be noted that the described alternate configuration (that includes two cervical disc replacement devices) presents the cervical disc replacement devices to the surgeon in a familiar manner. That is, by way of explanation, current cervical fusion surgery involves placing a fusion device (e.g., bone or a porous cage) in between the upper and middle cervical intervertebral bones, and in between the middle and lower vertebral bones, and attaching an elongated two-level cervical fusion plate to the anterior aspects of the bones. Widely used two-level cervical fusion devices (an example two level fusion plate **1350** is shown in anterior view in FIG. **13c** and in lateral view in FIG. **13d**) are configured with a pair of laterally spaced bone screw holes **1352a,1352b** on an upper end **1354** of the plate **1350**, a pair of laterally spaced bone screw holes **1356a,1356b** on a lower end **1358** of the plate **1350**, and a pair of laterally spaced bone screw holes **1360a,1360b** midway between the upper and lower ends **1354,1358**. To attach the plate **1350** to the bones, bone screws are disposed through the bone screw holes and into the corresponding bones. This prevents the bones from moving relative to one another, and allows the bones to fuse to one another with the aid of the fusion device.

[0097] Accordingly, as can be seen in FIG. **14b**, when the upper and lower elements **1500,1600** of the cervical disc replacement device **1400**, and the upper and lower elements **2500,2600** of the cervical disc replacement device **2400**, are held in the preferred spatial relationship and aligned for implantation, the upper element flange **1506** and lower element flange **2606**, and their bone screw holes **1508a,1508b** and **2608a,2608b**, present to the surgeon a cervical hardware and bone screw hole configuration similar to a familiar two level cervical fusion plate configuration (as described above, a middle pair of bone screws holes is not needed; however, middle bone screw holes are contemplated by the present invention for some embodiments, if necessary or desirable). The mounting of the elements **1500,1600** to the insertion plate **1700** allows the elements **1500,1600** to be manipulated as a single unit for implantation (by manipulating the insertion plate **1700**), similar to the way a cervical fusion plate is manipulatable as a single unit for attachment to the bones. Similarly, the mounting of the elements **2500,2600** to the insertion plate **2700** allows the elements **2500,2600** to be manipulated as a single unit for implantation (by manipulating the insertion plate **2700**), similar to the way a cervical fusion plate is manipulatable as a single unit for attachment to the bones. This aspect of the present invention simplifies and streamlines the cervical disc replacement device implantation procedure.

[0098] While there has been described and illustrated specific embodiments of cervical disc replacement devices and insertion instrumentation, it will be apparent to those skilled in the art that variations and modifications are possible without deviating from the broad spirit and principle of the invention. The invention, therefore, shall not be limited to the specific embodiments discussed herein.

1. (canceled)
2. A method comprising:
 - (a) connecting first and second elements of an intervertebral implant to an insertion member;
 - (b) inserting a portion of the insertion member into an insertion instrument; and
 - (c) implanting the intervertebral implant into an intervertebral space between first and second vertebral bodies of a spine such that the first element contacts the first vertebral body and the second element contacts the second vertebral body,
 wherein the implanting steps is performed without allowing the first and second elements of the intervertebral implant to move with respect to one another or the insertion instrument.
3. The method of claim **2**, further comprising the step of removing the portion from the insertion instrument.
4. The method of claim **3**, further comprising the step of disconnecting the insertion member from the first and second elements.
5. The method of claim **2**, wherein the inserting step includes inserting a projection of the insertion member into a bore of the insertion instrument.
6. The method of claim **2**, wherein the implanting step is performed without first and second articulation surfaces of the first and second elements respecting moving with respect to each other.
7. The method of claim **6**, wherein the implanting step is performed without the insertion member rotating with respect to the insertion instrument.

8. The method of claim **2**, wherein the connecting step includes placing a mounting screw through a first opening of the insertion member and into the intervertebral disc implant.

9. The method of claim **2**, further comprising the step of fixing the first and second elements to the first and second vertebral bodies respectively.

10. The method of claim **9**, wherein the fixing step includes placing a first screw through the first element and into the first vertebral body and placing a second screw through the second element and into the second vertebral body.

11. A method comprising:

- (a) inserting a portion of an insertion member holding first and second members of an intervertebral implant into an insertion instrument;
- (b) implanting the intervertebral implant into an intervertebral space between first and second vertebral bodies of a spine such that the first element contacts the first vertebral body and the second element contacts the second vertebral body, without allowing the first and second elements of the intervertebral implant to move with respect to one another or the insertion instrument;
- (c) removing the portion from the insertion instrument; and
- (d) disconnecting the insertion member from the first and second elements.

12. The method of claim **11**, further comprising the step of connecting the first and second elements to the insertion member.

13. The method of claim **12**, wherein the connecting step includes placing a mounting screw through a first opening of the insertion member and into the intervertebral disc implant.

14. The method of claim **11**, wherein the inserting step includes inserting a projection of the insertion member into a bore of the insertion instrument.

15. The method of claim **11**, wherein the implanting step is performed without first and second articulation surfaces of the first and second elements respecting moving with respect to each other.

16. The method of claim **15**, wherein the implanting step is performed without the insertion member rotating with respect to the insertion instrument.

17. The method of claim **11**, further comprising the step of fixing the first and second elements to the first and second vertebral bodies respectively.

18. The method of claim **17**, wherein the fixing step includes placing a first screw through the first element and into the first vertebral body and placing a second screw through the second element and into the second vertebral body.

19. A method comprising:

- (a) connecting first and second elements of an intervertebral implant to an insertion member;
- (b) inserting a portion of the insertion member into an insertion instrument;
- (c) implanting the intervertebral implant into an intervertebral space between first and second vertebral bodies of a spine such that the first element contacts the first vertebral body and the second element contacts the second vertebral body without allowing first and second articulation surfaces of the first and second elements of the intervertebral implant to move with respect to one another or the insertion instrument rotating with respect to the insertion instrument;
- (d) removing the portion from the insertion instrument; and
- (e) disconnecting the insertion member from the first and second elements.

20. The method of claim **19**, further comprising the step of fixing the first and second elements to the first and second vertebral bodies respectively.

21. The method of claim **20**, wherein the fixing step includes placing a first screw through the first element and into the first vertebral body and placing a second screw through the second element and into the second vertebral body.

* * * * *